

(19) **DANMARK**

(10) **DK/EP 3145684 T3**



(12) **Oversættelse af
europæisk patentskrift**

Patent- og
Varemærkestyrelsen

-
- (51) Int.Cl.: **B 26 D 1/547 (2006.01)** **B 26 B 27/00 (2006.01)** **B 26 D 5/08 (2006.01)**
- (45) Oversættelsen bekendtgjort den: **2024-03-18**
- (80) Dato for Den Europæiske Patentmyndigheds bekendtgørelse om meddelelse af patentet: **2023-12-13**
- (86) Europæisk ansøgning nr.: **15726885.5**
- (86) Europæisk indleveringsdag: **2015-05-20**
- (87) Den europæiske ansøgnings publiceringsdag: **2017-03-29**
- (86) International ansøgning nr.: **EP2015061093**
- (87) Internationalt publikationsnr.: **WO2015177201**
- (30) Prioritet: **2014-05-20 GB 201408938**
- (84) Designerede stater: **AL AT BE BG CH CY CZ DE DK EE ES FI FR GB GR HR HU IE IS IT LI LT LU LV MC MK MT NL NO PL PT RO RS SE SI SK SM TR**
- (73) Patenthaver: **Belron International Limited, Milton Park , Stroude Road, Egham, Surrey TW20 9EL, Storbritannien**
- (72) Opfinder: **FINCK, William, 31 Doddinghurst Road, Brentwood, Essex CM15 9EP, Storbritannien**
- (74) Fuldmægtig i Danmark: **Murgitroyd & Company, Mannerheimvägen 12 B, 5:e våningen, FI-00100 Helsingfors, Finland**
- (54) Benævnelse: **Fjernelse af glaspanel**
- (56) Fremdragne publikationer:
WO-A1-2006/030212
CH-A2- 702 761
DE-A1- 2 252 862
DE-U1- 29 824 304
US-A1- 2013 037 648

DESCRIPTION

[0001] This invention relates generally to glazing panel removal and more particularly to glazing panel removal techniques using a cutting wire or other length of cutting filament to remove vehicle glazing panels.

[0002] Glazing panel removal techniques are known using wire winding tools. Such an arrangement is shown in for example WO2006/030212 which discloses winder unit having a pair of winder spools and guide pulleys mounted outwardly of the winder spools. Another known glazing panel removal system is described in US2013/037648, which includes a winder unit and a separate dispenser unit for mounting on the glazing panel. More recently techniques have been developed which use synthetic plastics fibre line in place of wire.

[0003] An improved tool for use in such cutting techniques has now been devised.

[0004] The present invention provides a glazing panel removal device comprising a winder unit having:

first and second winder spools for winding a cutting filament;

drive means for driving the winder spools.

The invention is characterised in that the drive means comprises a single or common drive input for driving both the first and second winder spools.

[0005] In one embodiment the drive means comprises a rotary input drive means, preferably arranged such that driving the rotary input in a first rotary direction causes winding of the filament onto the first winder spool and driving the rotary input in the opposite direction causes winding of the filament onto the second winder spool.

[0006] In certain embodiments, it is preferred that the drive means is arranged to be configured to either:

1. i) drive the winder spools simultaneously or
2. ii) drive one of the winder spools, whilst permitting the other to rotate without being driven.

[0007] The drive means is arranged to be configured to drive the winder spool or spools such that the filament is wound onto one spool whilst being wound simultaneously off the other.

[0008] It is preferred that the drive means is arranged to be configured between a configuration in which filament is permitted to be wound off one of the spools and a configuration in which the filament is prevented from winding off that same spool.

[0009] This may be achieved for example by means of using a brake arrangement, which may be an adjustable brake arrangement arranged to vary the torque required to wind the filament off either of the winder spools. With the brake fully applied the winding off torque is so high that the filament is prevented from being wound off. With the brake partially applied the winding off torque is less and the filament can be wound off if the required torque is applied. This enables the torque for slip cutting to be adjusted.

[0010] In one embodiment the drive means may comprise an input drive shaft comprising the drive input and separate transmission shafts transmitting rotary motion to drive respective winder spools, the transmission shafts extending transversely to the input drive shaft.

[0011] In a preferred embodiment the device may include a transmission comprising a common bevel gear arrangement for transmitting rotary motion to each of the winder spools.

[0012] In a preferred embodiment the device may include a transmission comprising respective one way bearings for transmitting rotary motion to each of the winder spools. A one way bearing is known in the art as a device that permits transmission of torque for rotation in a first direction but not for rotation in the opposed direction.

[0013] In a preferred embodiment one or more preferably both of the rotary winder spools are demountable from the unit.

[0014] In a preferred embodiment one or more preferably both of the winder spools are arranged to be mounted with respect to a driven shaft in an engaged position in which the spool is coupled to rotate with the driven shaft and a neutral position in which the spool can rotate independently of the driven shaft.

[0015] It is preferred that the winder spools are mounted to rotate on axes that are substantially co-axial with one another.

[0016] It is preferred that the device further comprises mounting means for mounting the device to a glazing panel. In a preferred embodiment the mounting means comprises one or more suction devices.

[0017] It is preferred that the device comprises one or more guide pulleys spaced from the winder spools.

[0018] The drive means may be configured to be manually driven (using a lever coupled with a drive shaft) or power driven. Beneficially the device is capable of being either manually driven or power driven. It is therefore preferably capable of coupling with a manual drive tool or a powered drive tool.

[0019] These and other aspects of the present invention will be apparent from and elucidated

with reference to, the embodiment described herein.

[0020] An embodiment of the present invention will now be described, by way of example only, and with reference to the accompany drawings, in which:

Figure 1 is a plan view of an exemplary embodiment of winder unit in accordance with the invention;

Figure 2 is a sectional view of the winder unit of figure 1;

Figure 3 is a schematic view of an exemplary winder unit according to the invention;

Figures 4A to 4E are schematic representations showing operation of the transmission/drive train of a unit in accordance with the invention;

Figures 5A and 5B show schematically the configuration if an adjustable friction brake arrangement suitable for operating in accordance with the invention;

Figures 6A and 6B show how the winder spools are mounted to the transmission shaft in accordance with an aspect of the invention;

Figure 7 is a perspective view of the embodiment of figures 1 and 2.

[0021] Referring initially to figures 1 2 and 7 in particular, there is shown a glazing panel removal device 1 in the form of a winder unit 1 to be mounted on a vehicle glazing panel, and in a first mode of operation being capable of being used with a cut out wire in a similar manner to the unit disclosed in WO2006/030212. In an alternative mode of operation the unit can be used in combination with a plastics fibre line filament in place of a cutting wire.

[0022] The unit is similar in certain respects to the winder unit disclosed in WO2006/030212, particularly in that it utilises a pair of spaced suction mounts 52 and also a pair of spaced winder spools 10,11 for winding the cutting filament in the worm either of the cutting wire or the cutting plastics fibre line. The unit also includes rotatable guide pulleys 54 55 56 57 for guiding the cutting filament 100 which are arranged in similar configuration to the arrangement of figure 12 in WO2006/030212.

[0023] The unit includes further 2 inclined or angled pulleys 61 62 which are provided to guide the filament 100 as it is wound onto and off a respective winder spool 10 11. These pulleys are provided because, contrary to the arrangement of WO2006/030212, the winder spools 10,11 are arranged upright, coaxially with one another and with their rotational axis horizontal (i.e. parallel to the general plane of the glazing panel to which the unit is mounted). This for ergonomic and ease of use reasons, particularly because the winder spools are demountable from their respective drive shafts 16 17 and the arrangement in this configuration makes for easy mounting and de-mounting.

[0024] A further departure from the arrangement shown in WO2006/030212 is that a single drive for driving both the winder spools 10 11 is provided. The single drive comprises a socket 64 coupled to a drive shaft 14. In one embodiment a rotary manual handle 68 can be coupled to drive the drive shaft 14 via the socket 64. In an alternative embodiment a powered drive tool can be coupled to the drive socket 64. The transmission system for driving the spools 10 11 will be described in detail below.

[0025] As shown in figure 2 the transmission for rotating the winder spools 10, 11 comprises a vertically orientated input drive shaft 14 to which is mounted a mitre gear 15. The mitre gear 15 drives a respective drive gear 22 23 for a respective spool drive shaft 16 17 to which the spools are mounted. Shaft bearings 18 are provided for the input shaft 14 and the drive shafts 16 17.

[0026] Importantly the gears 22 23 act to drive the shafts 16 17 through respective one way bearings 12 13. These ensure that torque is only transmitted to the respective drive shafts 16 17 when the respective gear 22 23 is rotated in one direction (opposite rotation directions for each of the gears 22 23). One way bearings are known in the art.

[0027] Also mounted to the respective shafts 16 17 are respective adjustable friction brake arrangements 41 42 which are controlled by operating a rotary control annulus 41a 42a which is cam profiled to urge a movable brake disc 25 26 to frictionally engage with fixed washers 27 in order to provide a braking effect. An alternative exemplary arrangement is shown in the schematic embodiment of figures 5A and 5B in which a wave compression spring 26 is provided between the brake actuator 42b and a friction washer 81. The friction washer 81 acts against a friction plate 82 mounted by means of a one way bearing 30 to the shaft 17. The control annulus 42a and the brake actuator 42b are cam profiled such that rotation of the annulus 42a results in axial movement of the brake actuator 42b.

[0028] In the embodiment of figures 1, 2 and 7 a series of fixed and rotary brake discs indicated at 27. The brake arrangement does not rotate with the shaft 16 or 17. One way bearings 30 ensure that friction is not applied by the brake to the shaft 16 17 whilst winding in the filament on the respective spool 10, 11. The brake only takes effect for winding in the opposite direction.

[0029] In use the transmission can be used in 2 modes, these being slip mode (in which the filament 100 is simultaneously wound off one spool as it is wound onto another) and non-slip mode (in which the filament is wound onto one of the spools whilst not being wound off the other). In slip mode the tension can be adjusted using the brake devices.

[0030] Non-slip mode is shown in figures 4A and 4B where the arrows show the rotation according to the right hand rule figure 4E. In figure 4A rotation of the drive shaft 14 and mitre gear 15 is clockwise. Torque is transferred via the one way bearing 13 to rotate the shaft 17 and spool 11 to wind in the filament 33. The one way bearing 30 on the brake device 41 is configured such that when the shaft 17 is driven, no brake is applied by brake 41.

[0031] In the situation of Figure 4A the brake 42 is fully applied and effective by means of torque being applied via the one way bearing 30 of brake 42 so as to apply braking friction to the shaft 16 to a degree sufficient to prevent rotation. Torque is not applied through the one way bearing 12 of gear 22 to drive the shaft 16. Consequently filament is not wound off spool 10 because the tension in the filament 100 is not sufficient to overcome the braking force of the brake 42.

[0032] For counter clockwise winding of the drive shaft 14, the situation is reversed as shown in figure 4B and filament is wound onto spool 10 but not off spool 11. In this configuration torque is not transferred through bearing 30 of brake 42. Torque is however applied via the bearing 30 of brake 41. The transmission is driving the shaft 16 because torque is applied via the bearing 12. No torque is applied via the bearing 13.

[0033] This non-slip cutting is achieved when the brakes 41 42 are full applied (or at least sufficiently applied to prevent rotation as a result of tension in the filament).

[0034] If the brakes 41 42 are not fully applied, then the slip cutting situation shown in figures 4C and 4D results. The braking force applied by the brakes 41 42 (when acting via the respective one way bearings 30) is not sufficient to prevent the tension in the filament on the winding off spool causing rotation of the spool 10 11 and slip cutting occurs as filament is wound off one spool whilst being simultaneously wound onto the other. In the clockwise drive shaft 14 rotation situation shown in figure 4C the shaft 17 is driven via the one way bearing 13 and the brake 41 torque is not being applied via the one way bearing 30. The one way bearing 30 of brake 42 is acting to transmit braking torque, but not sufficient to prevent the filament 100 from being wound off the spool 10. One way bearing 12 of gear 22 is not acting.

[0035] In the situation of counter clockwise rotation (as shown in figure 4D, the operation is reversed. Shaft 16 is driven by the active bearing 12 in order to wind on to spool 10. Shaft 17 rotates due to the torque applied via the filament 100 being wound off spool 11. Brake 41 is active but not sufficient to prevent the filament being wound off spool 11. Because the brake torque is adjustable, the tension in the filament required to effect winding off the relevant spool can be adjusted. This provides for adjustable slip cutting.

[0036] As an alternative to the transmission described, the gear train could be used to drive the shafts simultaneously in opposed directions but this would result in potentially a less versatile means of operation as the alternative modes of cutting would be more difficult to achieve.

[0037] The spools 10, 11 are mounted on respective drive shafts in 16 17 in two positions, a driving or engaged position in which they rotate with the driven shaft 16 17 and a neutral position in which they can rotate independently of the main drive shaft 16 17. The spools 10 11 are displaced axially outwardly from the drive position to the neutral position. In the neutral position the spools 10 11 are held to rotate with a rotatable shaft tip 16a 17a which is rotatably

fixed to the main shaft 16 17 by a respective axis pin 71. This is shown most clearly and schematically in figures 6A and 6B. Figure 6A shows the spool 11 in the engaged position. Figure 6B shows the spool 11 in the neutral position. The shaft tip 71 and the shaft are provided with magnets 92 93 and the spool has a ferrite insert 11a to ensure that the spool is held in the desired engaged or neutral position. A spring 73 is provided to control friction in the rotating tip 16a 17a.

[0038] The ability to engage neutral position is important to enable filament to be pulled off from the spools once it has already been wound on. This is necessary for example when using the fibre line filament during the set up procedure.

[0039] The cut out unit can be used in various techniques and procedures and is particularly versatile in this regard being capable for powered or manual use and also for use with traditional wire or the newer fibre line filament.

[0040] It should be noted that the above-mentioned embodiments illustrate rather than limit the invention, and that those skilled in the art will be capable of designing many alternative embodiments without departing from the scope of the invention as defined by the appended claims. In the claims, any reference signs placed in parentheses shall not be construed as limiting the claims. The word "comprising" and "comprises", and the like, does not exclude the presence of elements or steps other than those listed in any claim or the specification as a whole. In the present specification, "comprises" means "includes or consists of" and "comprising" means "including or consisting of". The singular reference of an element does not exclude the plural reference of such elements and vice-versa.

REFERENCES CITED IN THE DESCRIPTION

Cited references

This list of references cited by the applicant is for the reader's convenience only. It does not form part of the European patent document. Even though great care has been taken in compiling the references, errors or omissions cannot be excluded and the EPO disclaims all liability in this regard.

Patent documents cited in the description

- [WO2006030212A \[0002\] \[0021\] \[0022\] \[0022\] \[0023\] \[0024\]](#)
- [US2013037648A \[0002\]](#)

PATENTKRAV:

1. Enhed til fjernelse af glaspanel omfattende en oprulningsenhed (1) med:
5 første og anden oprulningsspoler (10, 11) til oprulning af et skæringsfilament (100);
drevanordning til at drive oprulningsspolerne (10, 11);
kendetegnet ved, at drevanordningen omfatter en enkelt eller fælles drevindgang til at drive både den første og anden oprulningsspole (10, 11).
- 10 2. Enhed til fjernelse af glaspanel ifølge krav 1, hvor drevanordningen er placeret til at blive konfigureret til at drive en af oprulningsspolerne (10, 11), mens den anden kan rotere uden at blive drevet.
- 15 3. Enhed til fjernelse af glaspanel ifølge krav 2, hvor drevanordningen er placeret til at blive konfigureret til at drive oprulningsspolerne (10, 11) på en sådan måde, at filamentet (100) oprulles på en spole (10,11) samtidigt med at det rulles af den anden.
- 20 4. Enhed til fjernelse af glaspanel ifølge ethvert af foregående krav, hvor drevanordningen er placeret til at blive konfigureret på en sådan måde, at filamentet (100) forhindres i at blive rullet af en af oprulningsspolerne (10, 11), mens det rulles på den anden.
- 25 5. Enhed til fjernelse af glaspanel ifølge ethvert af foregående krav, hvor enheden omfatter en justerbar bremseanordning (41, 42) placeret til at variere momentet, der kræves for at rulle filamentet (100) af en af oprulningsspolerne (10, 11).
- 30 6. Enhed til fjernelse af glaspanel ifølge ethvert af foregående krav, hvor drevanordningen omfatter en indgangsdrivaksel (14) omfattende drivindgangs- og separate transmissionsaksler (16, 17), der overfører en rotationsbevægelse til at drive de respektive oprulningsspoler (10, 11), transmissionsakserne (16, 17) strækker sig tværgående til indgangsdrivakslen (14).
- 35 7. Enhed til fjernelse af glaspanel ifølge ethvert af foregående krav, hvor enheden omfatter:
en roterende indgangsdrivanordning; og
en transmission omfattende:
respektive envejs-lejer (12, 13) til at overføre en rotationsbevægelse til hver af oprulningsspolerne (10, 11) på en sådan måde, at hvis rotationsindgangen drives i en første rotationsretning, oprulles filamentet (100) på den første oprulningsspole (10, 11), og hvis rotationsindgangen drives i den modsatte

retning, oprulles filamentet (100) på den anden oprulningsspole (10, 11).

- 5 8. Enhed til fjernelse af glaspanel ifølge krav 7, hvor transmissionen derudover omfatter en fælles konisk gearanordning (15) for at overføre en rotationsbevægelse til hver af oprulningsspoleerne (10, 11).
- 10 9. Enhed til fjernelse af glaspanel ifølge ethvert af foregående krav, hvor en eller begge de roterende oprulningsspoler (10, 11) kan afmonteres fra enheden, og/eller hvor oprulningsspoleerne (10, 11) er monteret til at rotere på akser, der hovedsageligt er koaksiale i forhold til hinanden.
- 15 10. Enhed til fjernelse af glaspanel ifølge ethvert af foregående krav, hvor en eller begge oprulningsspoler (10, 11) er placeret til at blive monteret i forhold til en drivaksel (16, 17) i en position i indgreb, hvor spolen (10, 11) kobles til at rotere med drivakslen (16, 17), og i en neutral position, hvor spolen (10, 11) kan rotere uafhængigt af drivakslen (16, 17).
- 20 11. Enhed til fjernelse af glaspanel ifølge ethvert af foregående krav, hvor enheden derudover omfatter monteringsanordning til montering af enheden på et glaspanel, hvor monteringsanordningen omfatter en eller flere sugeholdere (52).

DRAWINGS

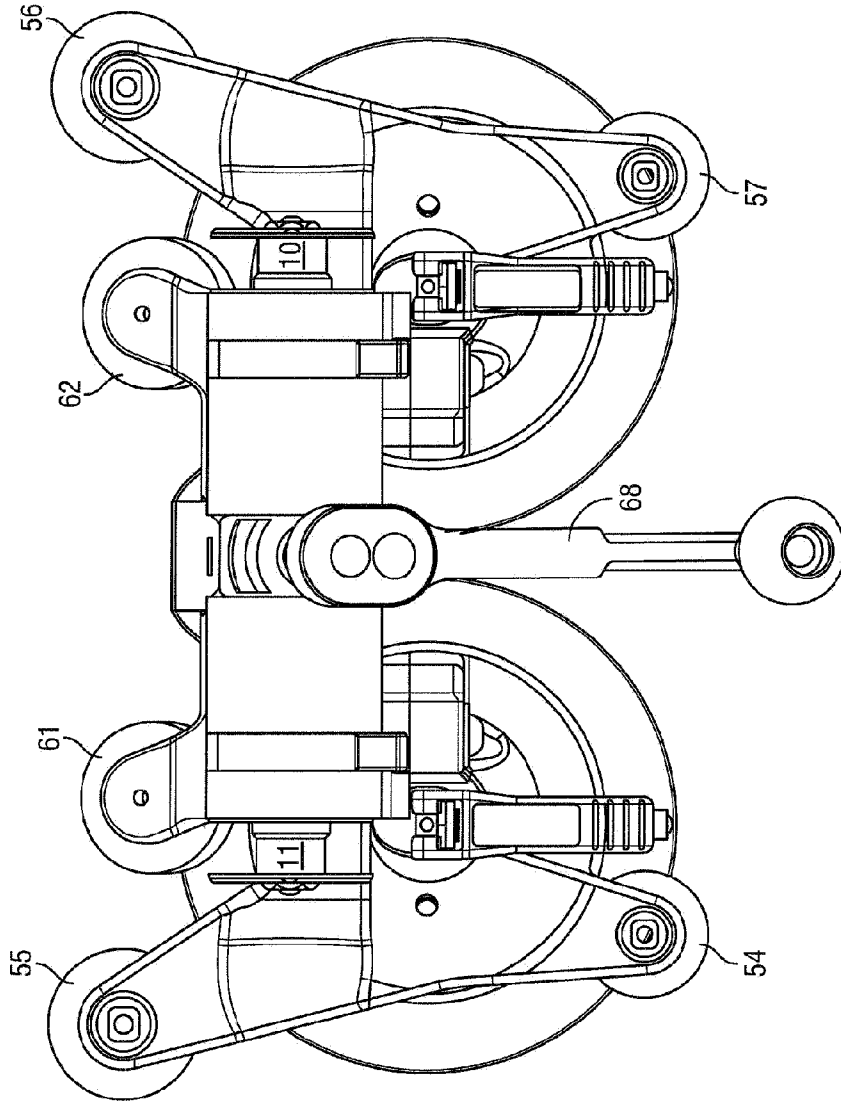

FIG. 1

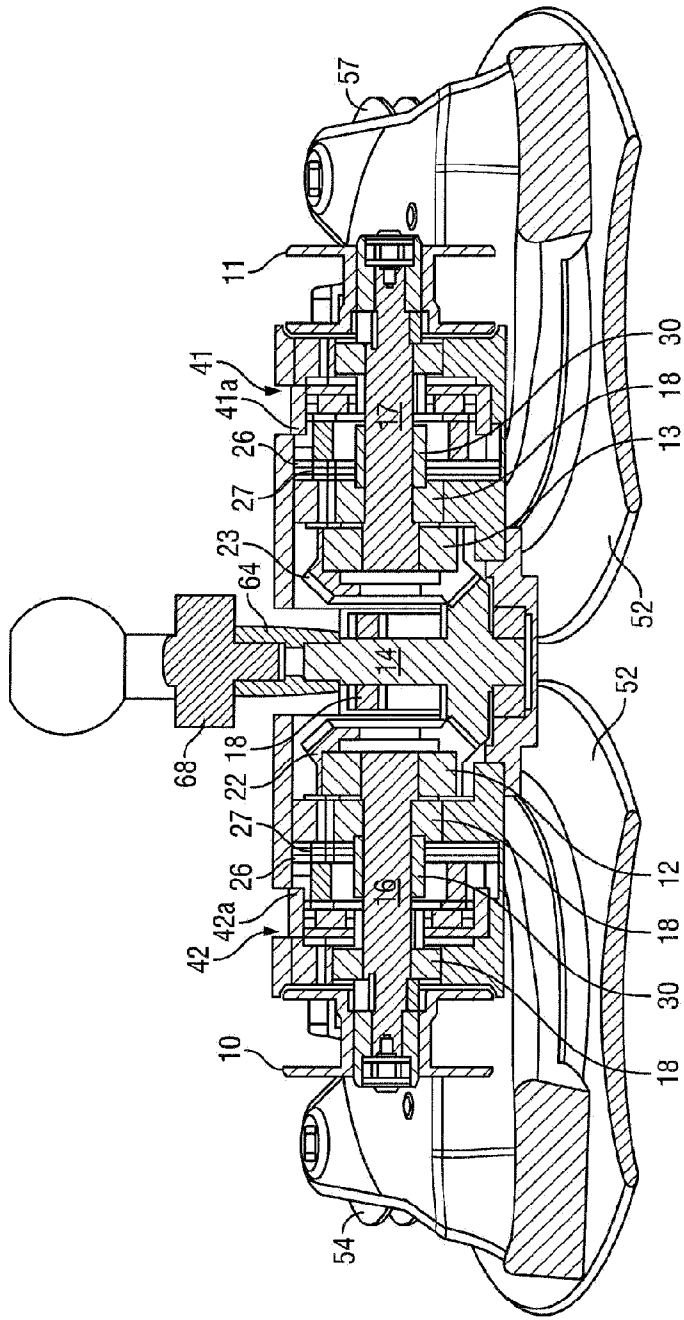

FIG. 2

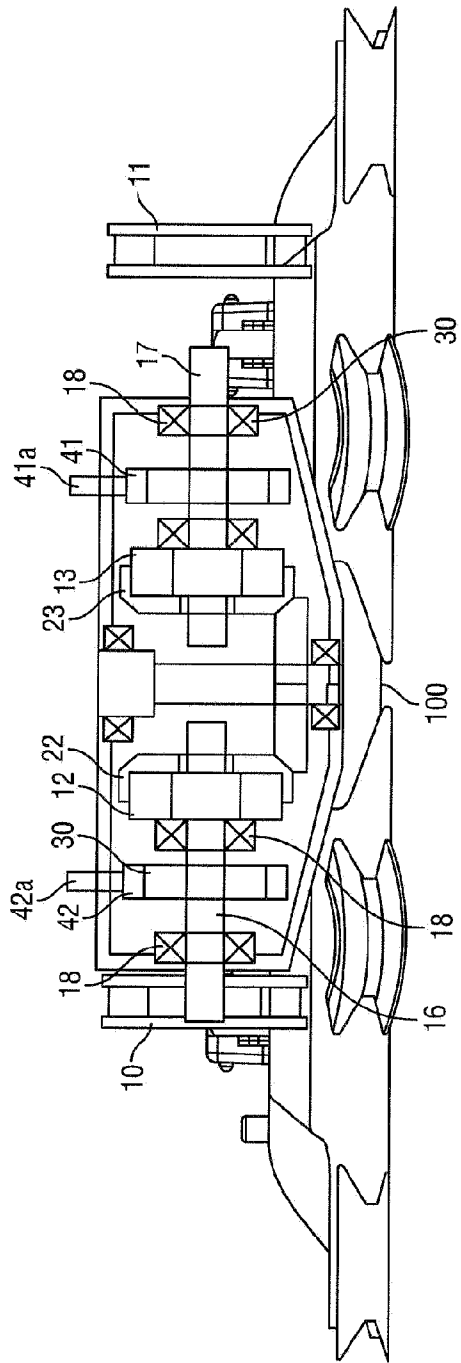

FIG. 3

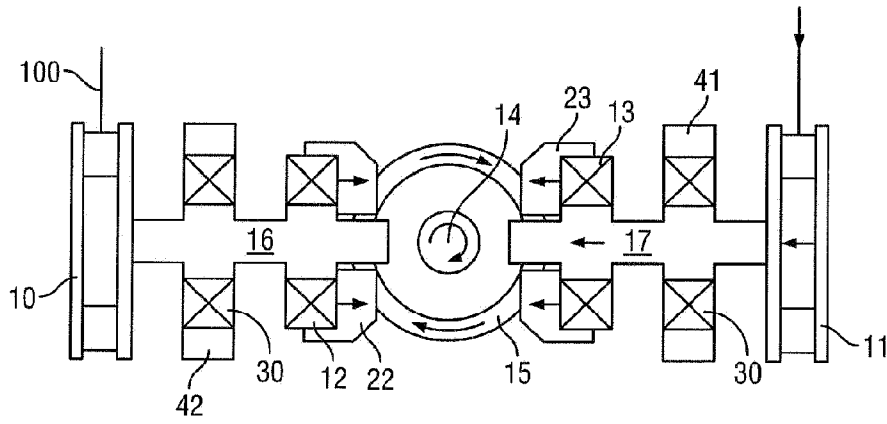

FIG. 4A

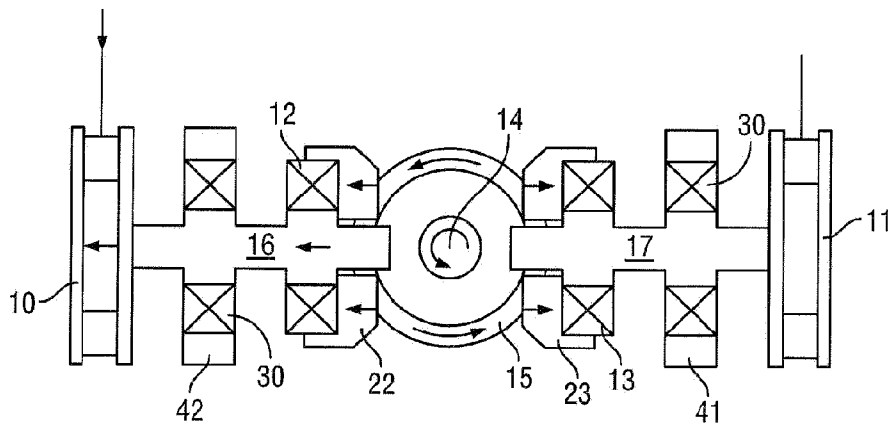

FIG. 4B

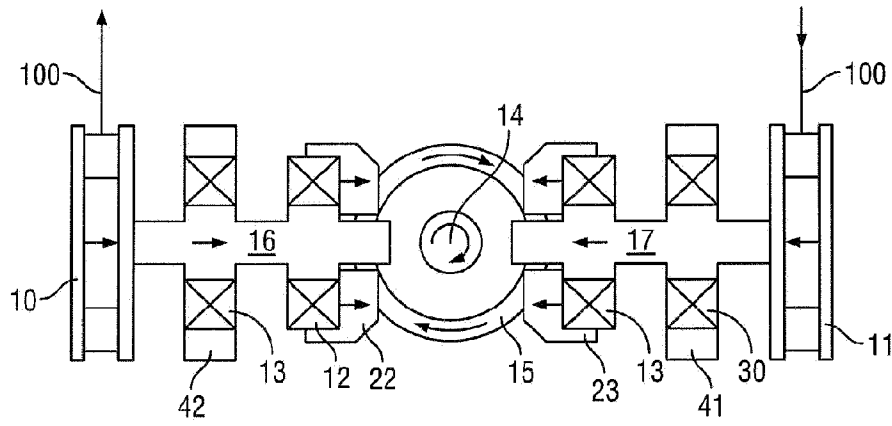

FIG. 4C

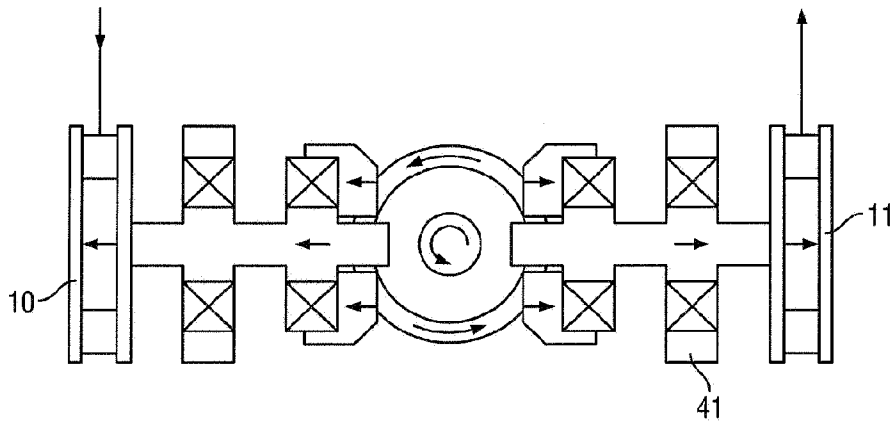

FIG. 4D

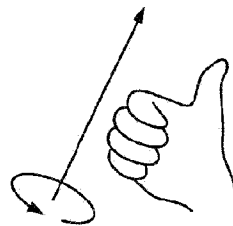

FIG. 4E

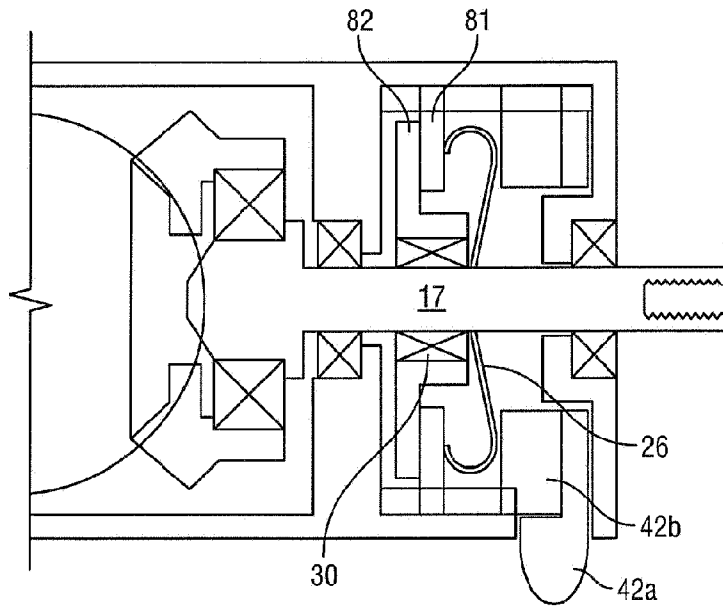

FIG. 5A

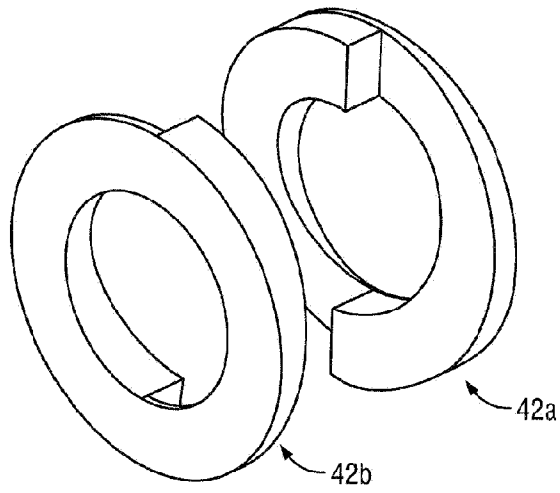

FIG. 5B

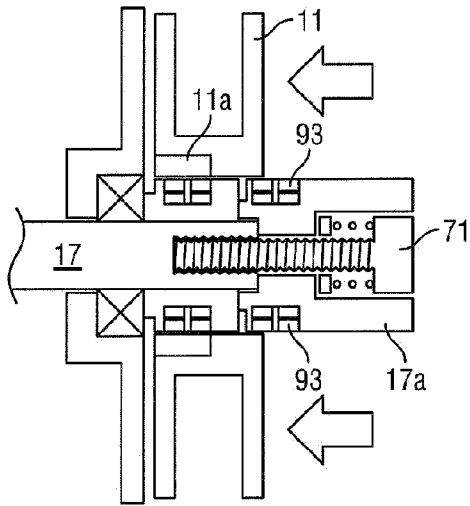

FIG. 6A

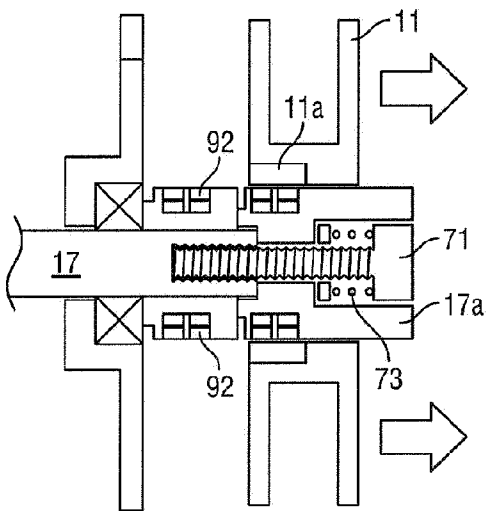

FIG. 6B

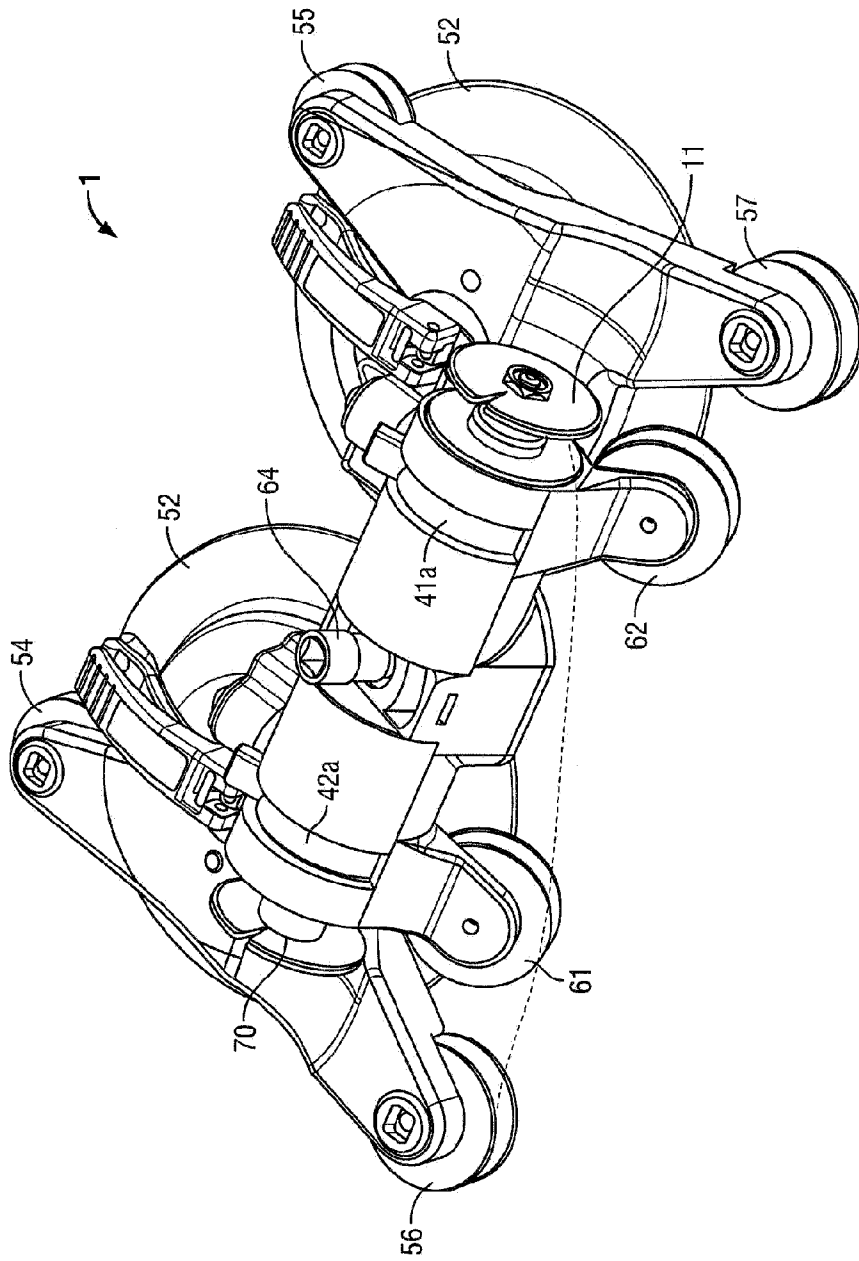

FIG. 7