



US 20230241542A1

(19) **United States**

(12) **Patent Application Publication**

Adamek et al.

(10) **Pub. No.: US 2023/0241542 A1**

(43) **Pub. Date: Aug. 3, 2023**

(54) **FILTER MEDIA, FILTER MEDIA PACKS, AND FILTER ELEMENTS**

Publication Classification

(51) **Int. Cl.**
B01D 46/52 (2006.01)
(52) **U.S. Cl.**
CPC *B01D 46/526* (2013.01); *B01D 46/527* (2013.01)

(71) Applicant: **Donaldson Company, Inc.**,
Bloomington, MN (US)

(72) Inventors: **Daniel E. Adamek**, Bloomington, MN (US); **Scott M. Brown**, Faribault, MN (US); **Mark A. Sala**, Lino Lakes, MN (US)

(57) **ABSTRACT**

(21) Appl. No.: **18/101,909**

(22) Filed: **Jan. 26, 2023**

Related U.S. Application Data

(63) Continuation of application No. 16/438,183, filed on Jun. 11, 2019, now Pat. No. 11,596,893.

(60) Provisional application No. 62/683,542, filed on Jun. 11, 2018.

Embodiments include an air filtration media element comprising a plurality of layers of fluted media, each layer comprising a facing sheet and a fluted sheet, the fluted sheet comprising a first plurality of flutes and a second plurality of flutes, the first and second plurality of flutes being arranged in a parallel flow configuration; wherein the first and second plurality of flutes exhibit regular repeating differences in flute shape, flute size, flute height, flute width, cross-flute area, or filter media.

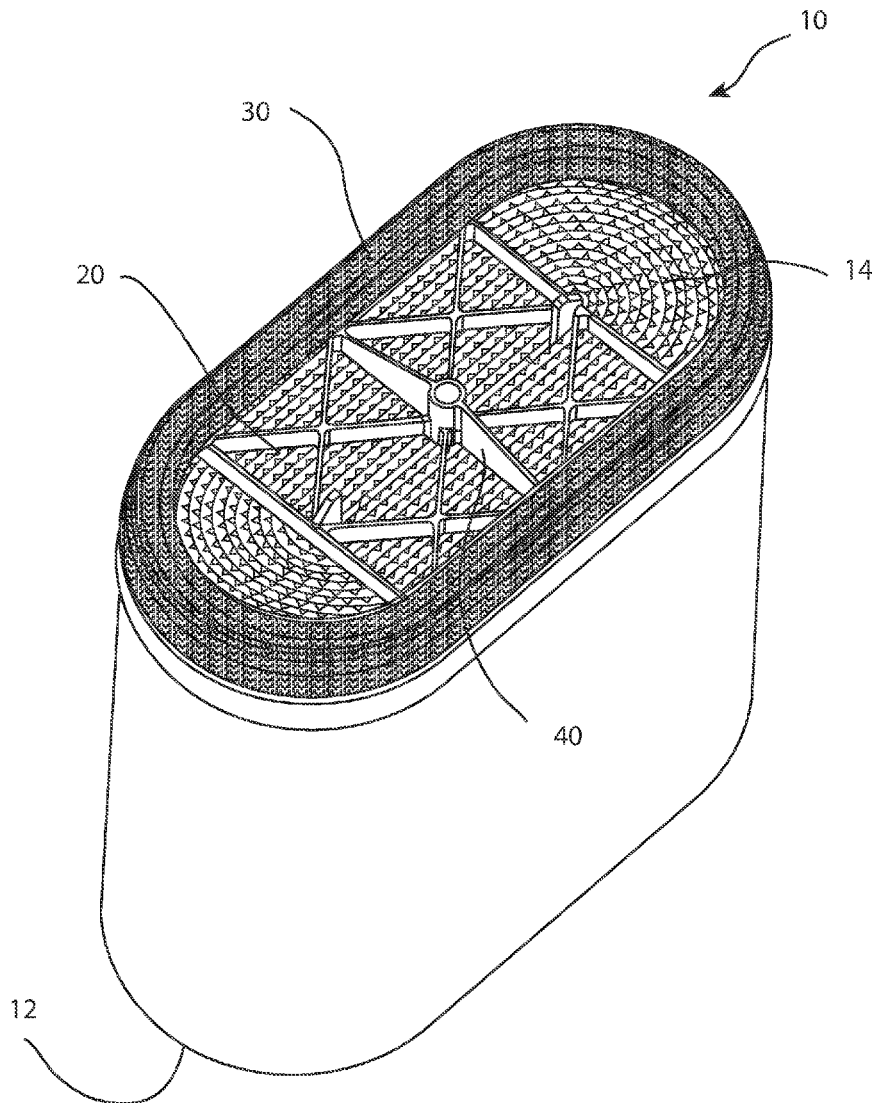

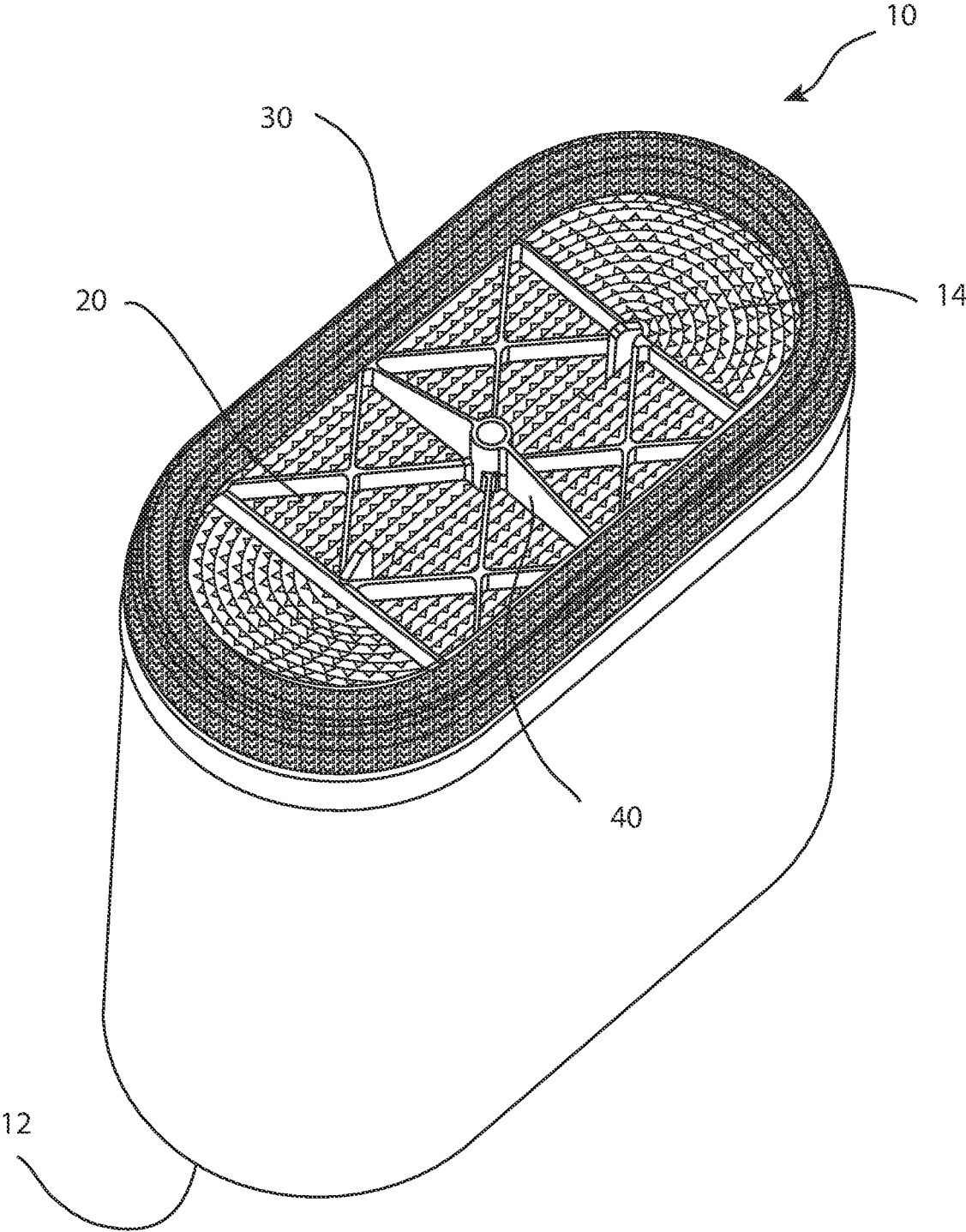

FIG. 1

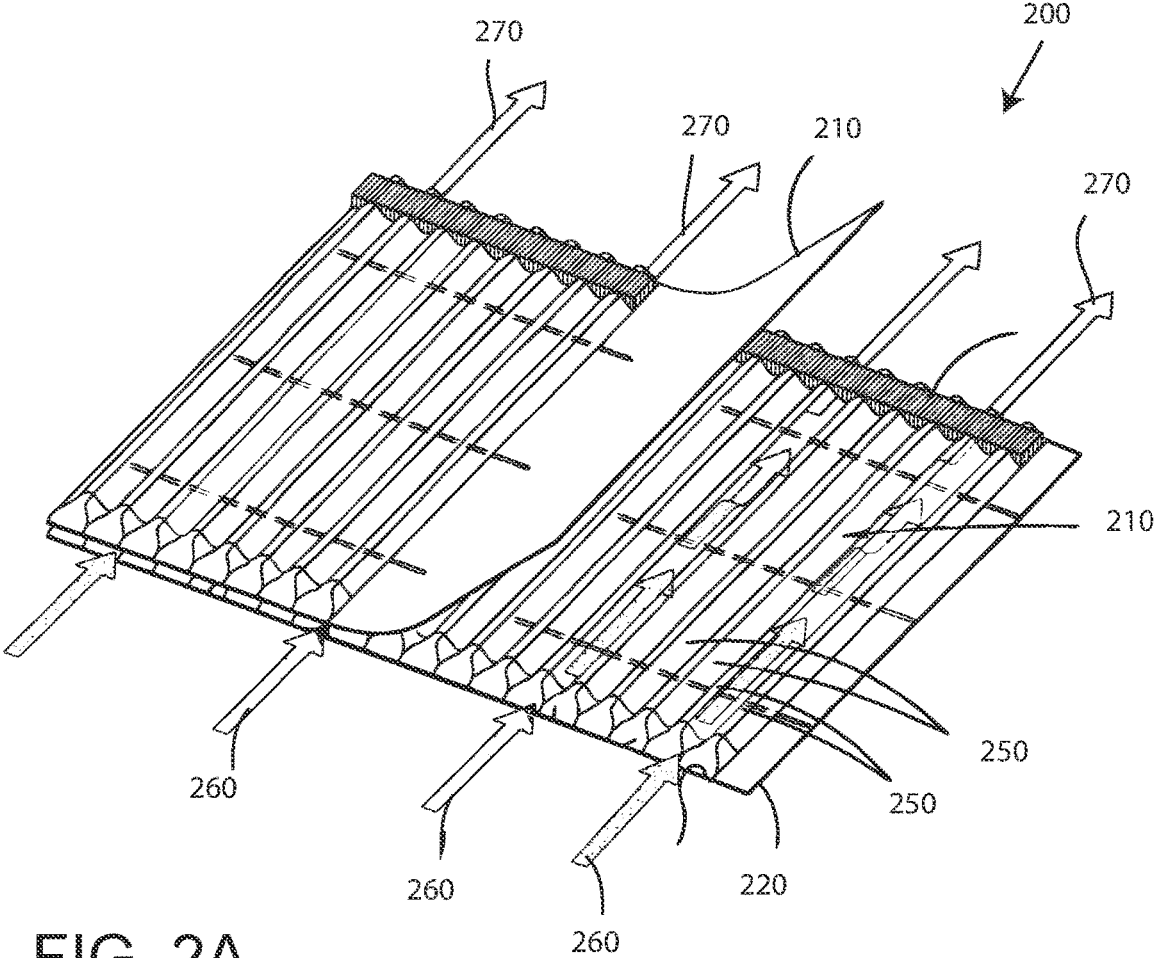

FIG. 2A

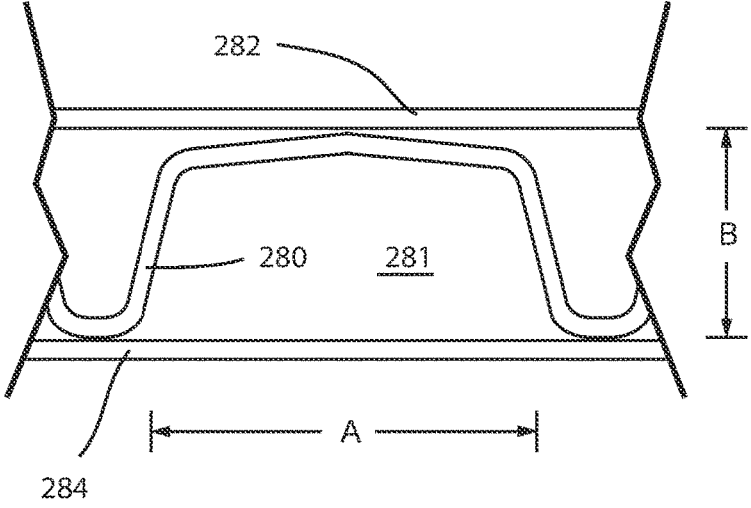

FIG. 2B

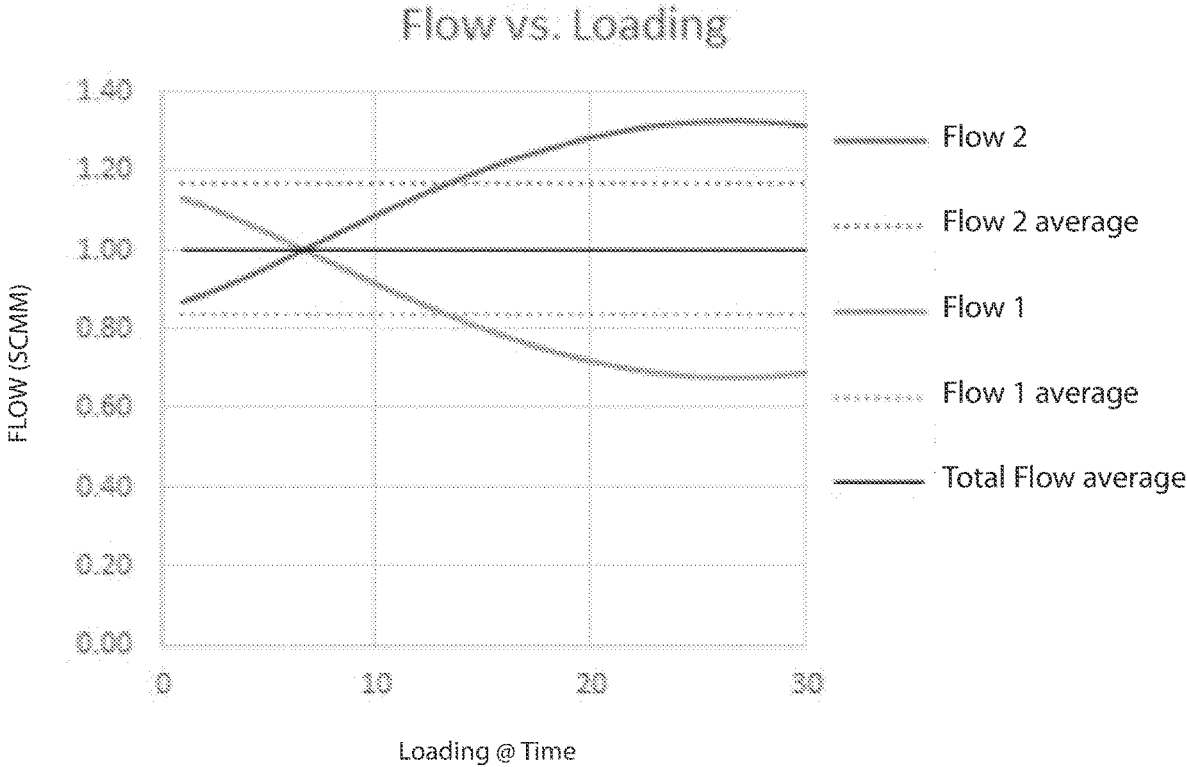

FIG. 3A

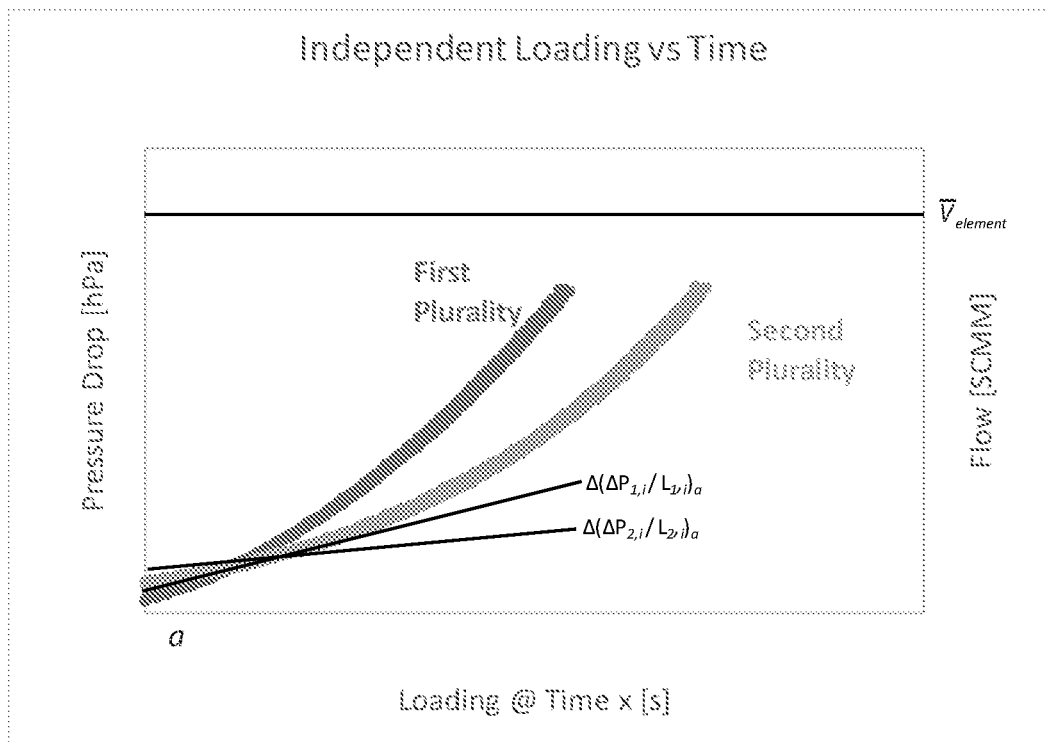

FIG. 3B

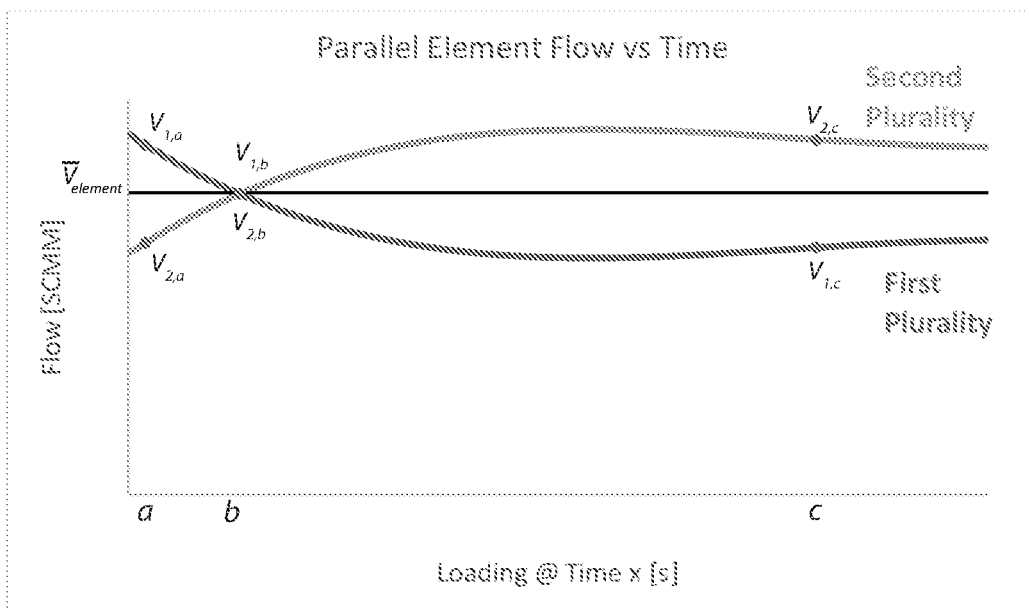

FIG. 3C

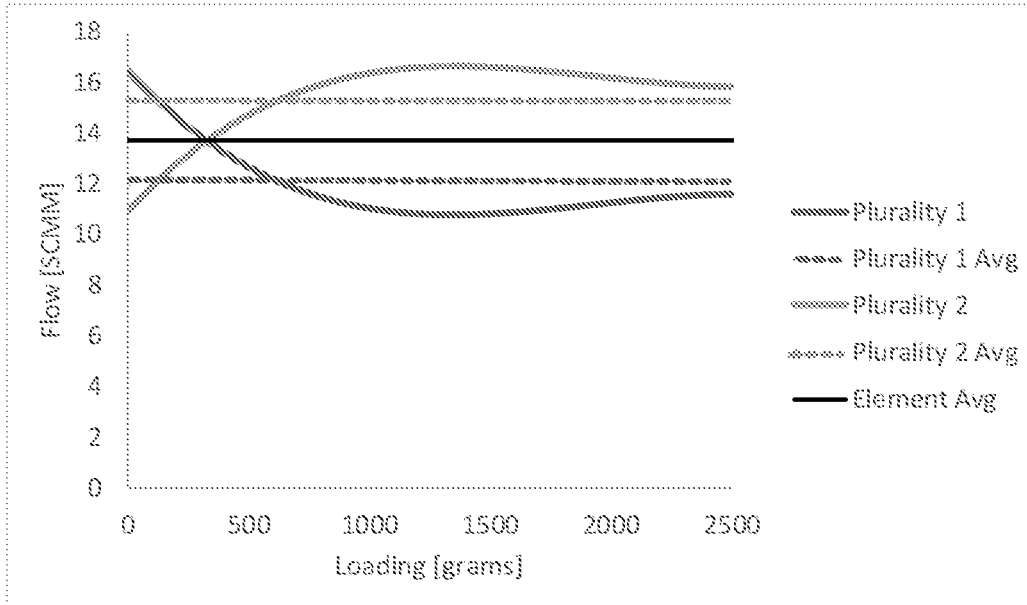

FIG. 3D

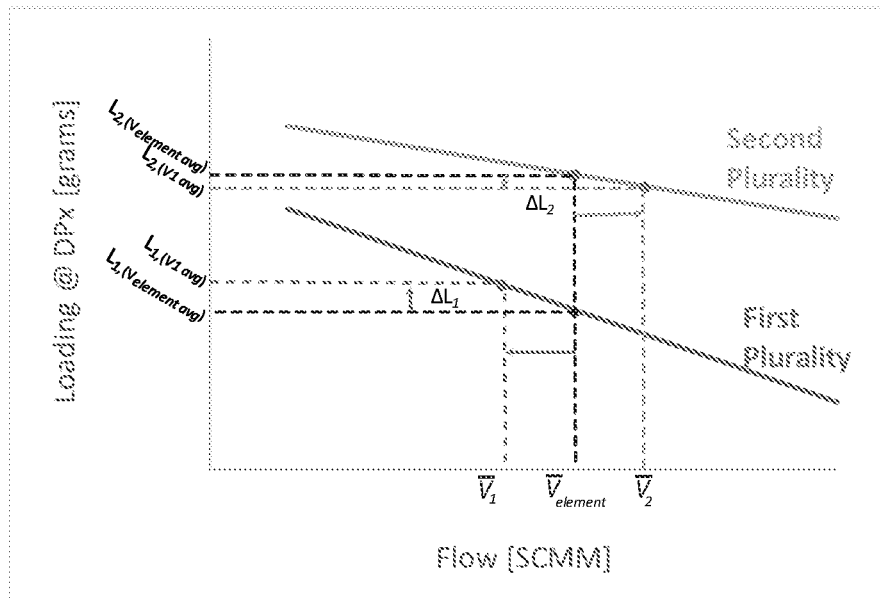

FIG. 3E

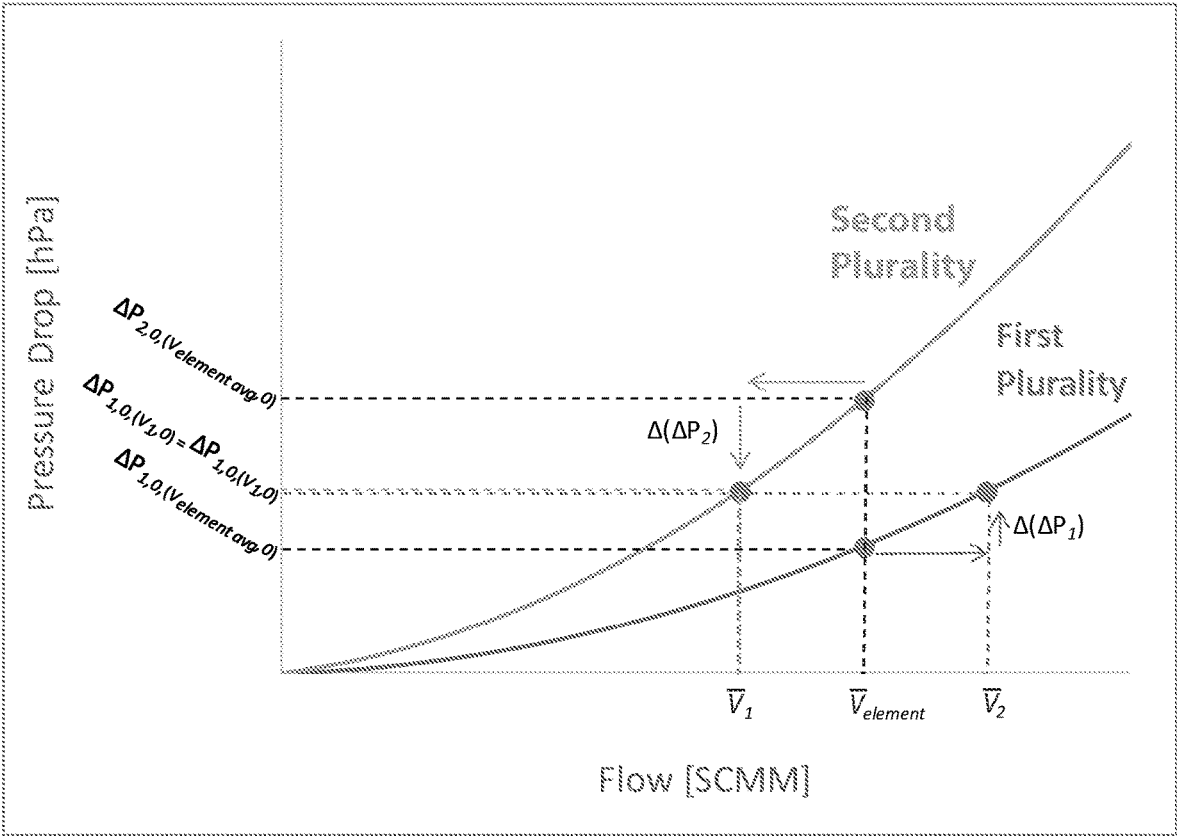

FIG. 3F

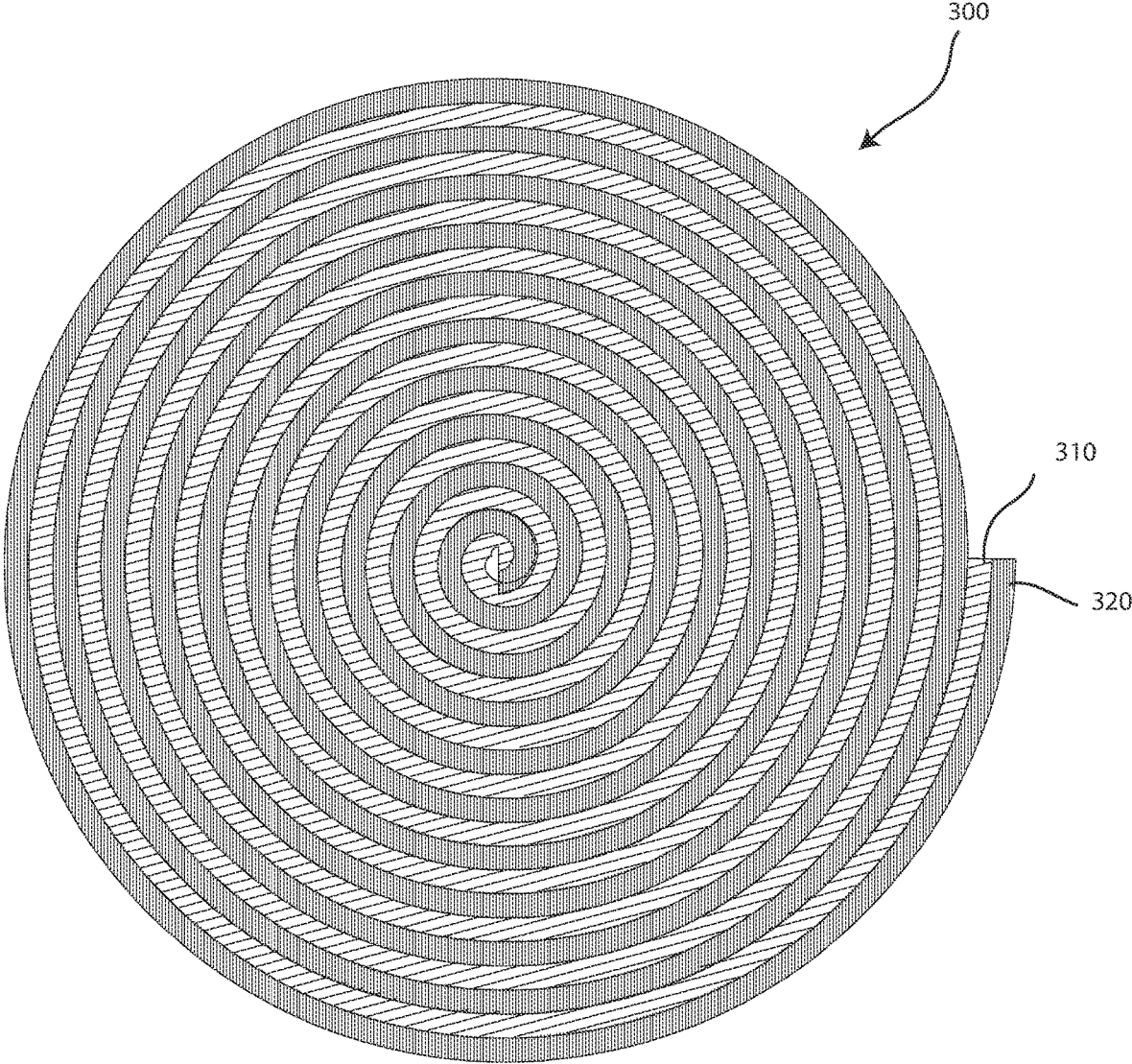

FIG. 4A

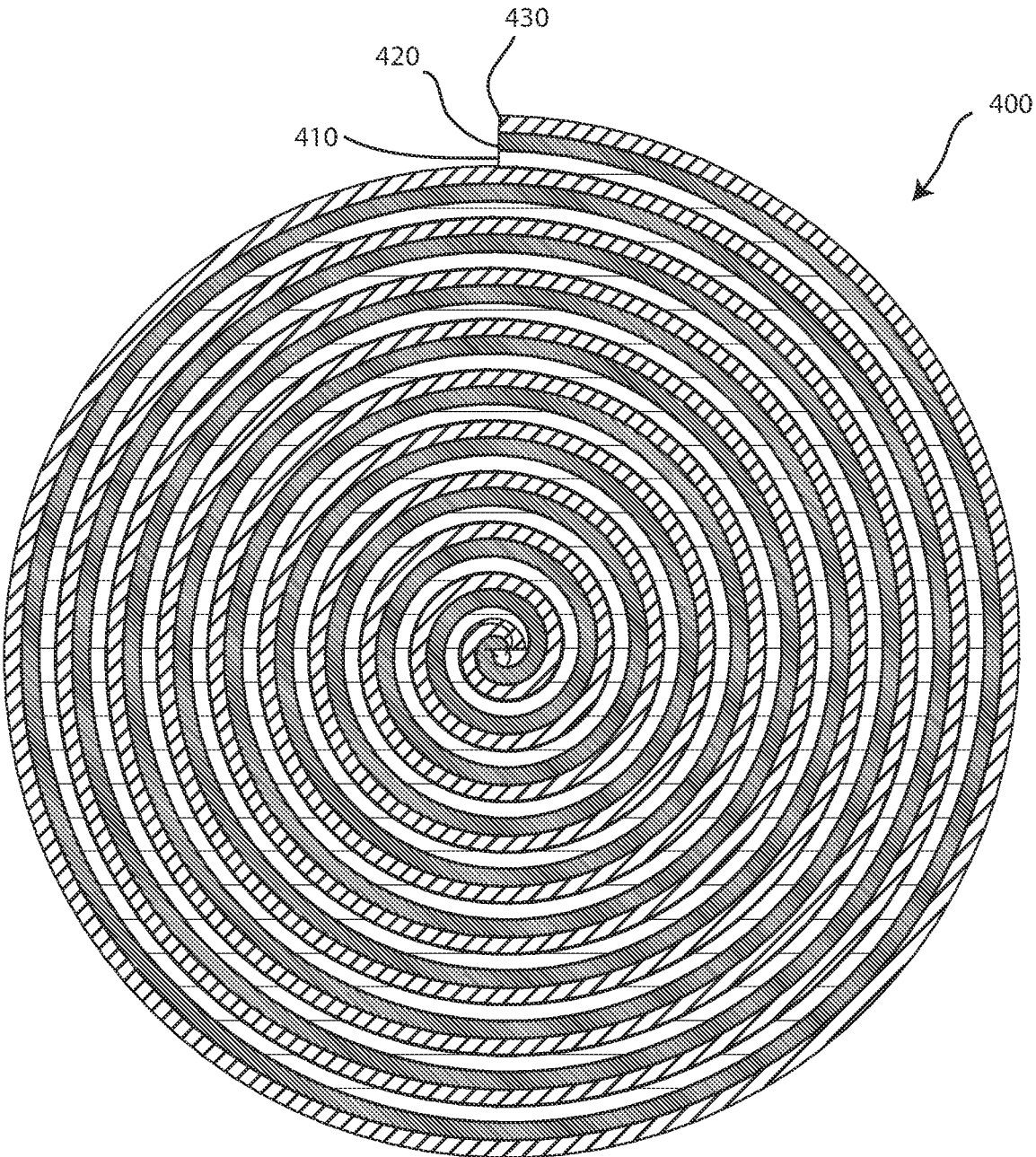

FIG. 4B

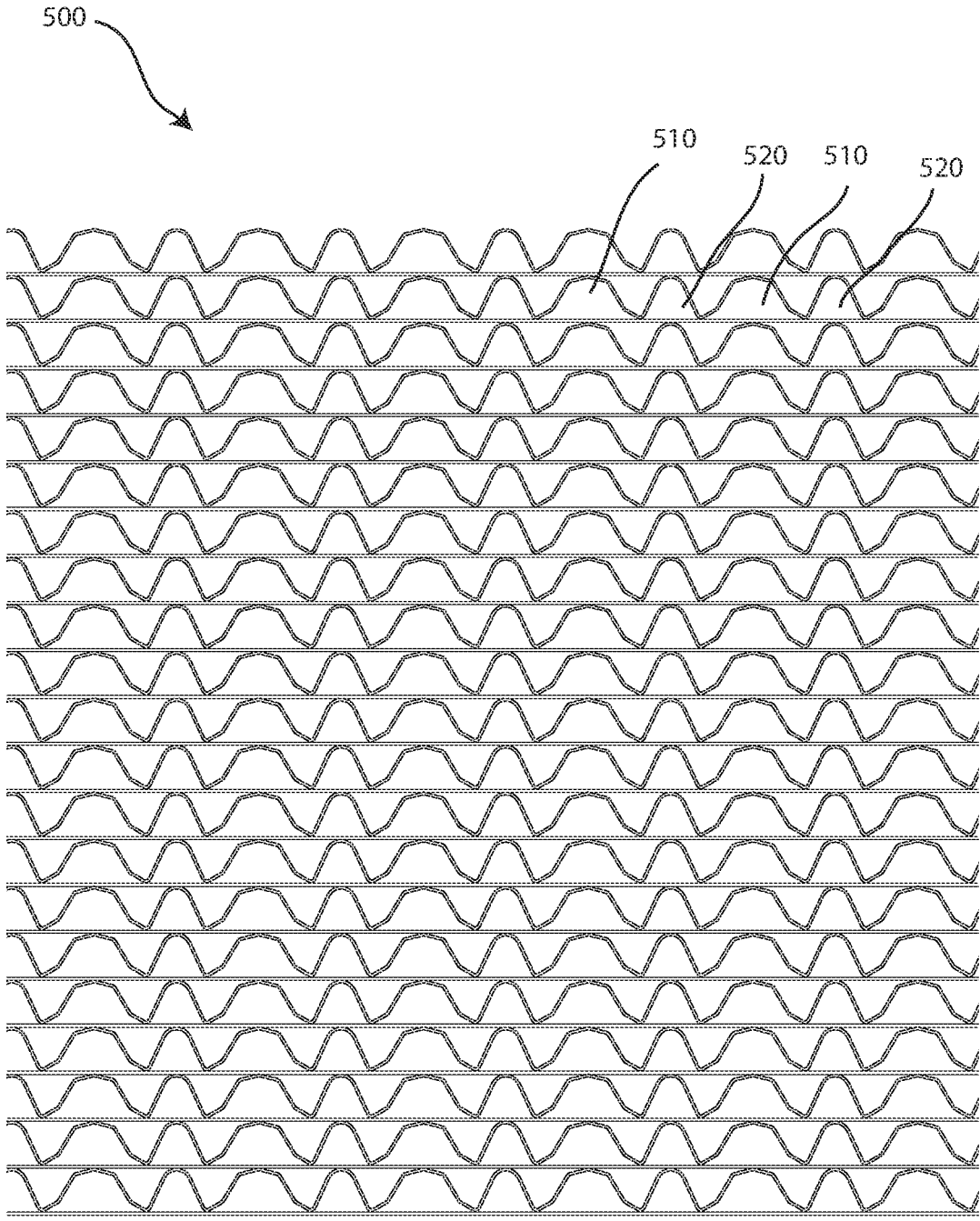

FIG. 5

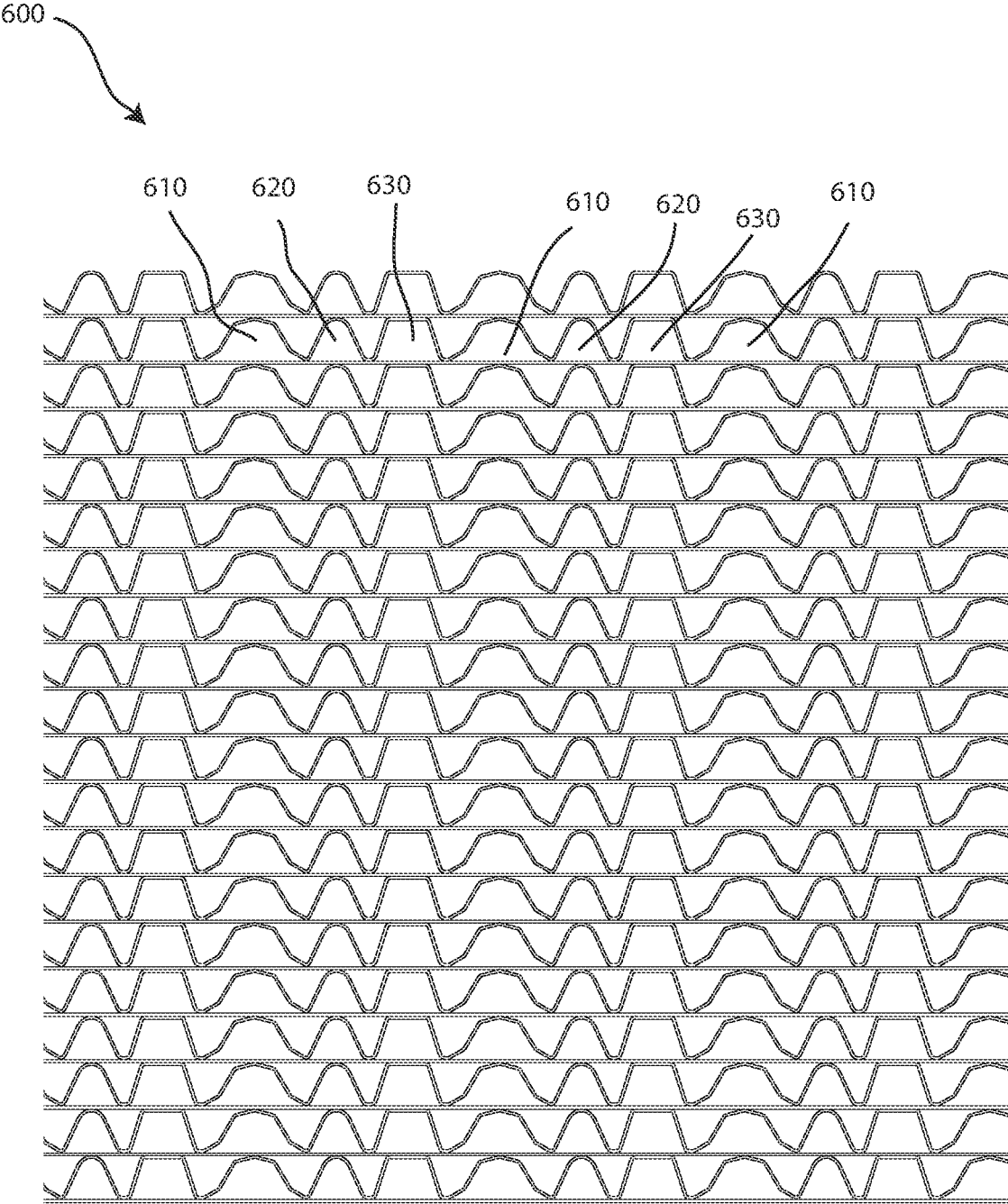

FIG. 6

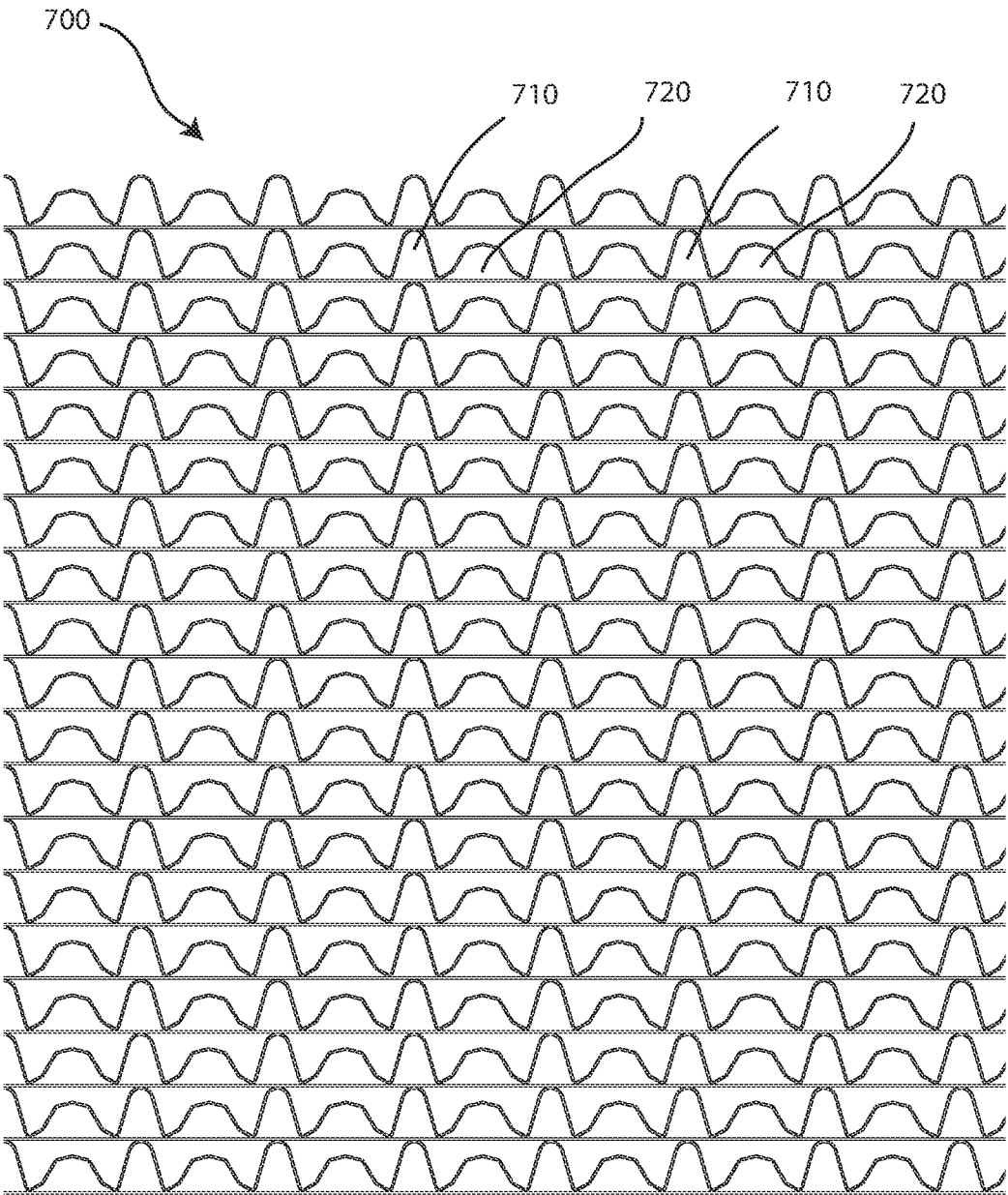

FIG. 7

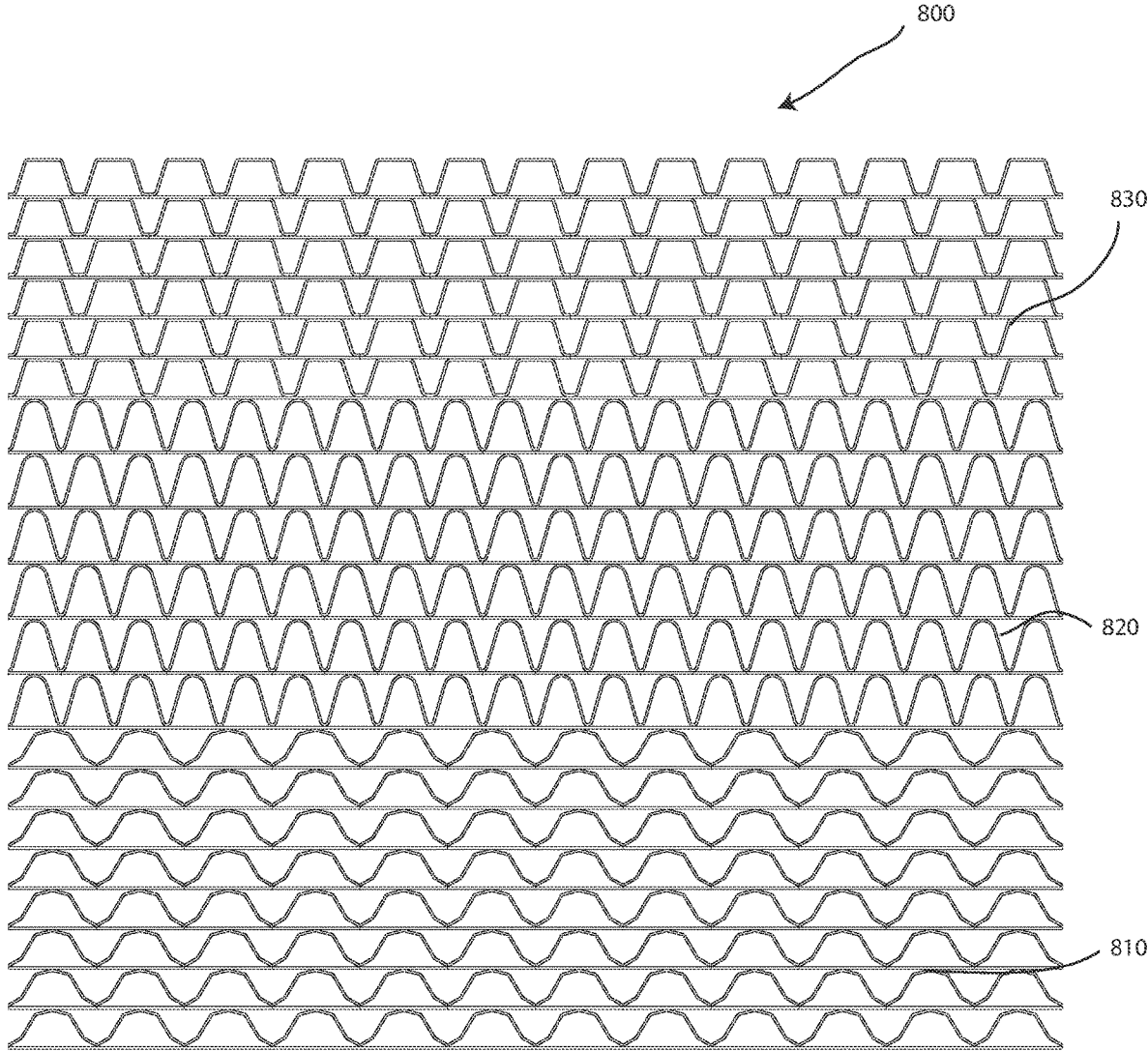

FIG. 8

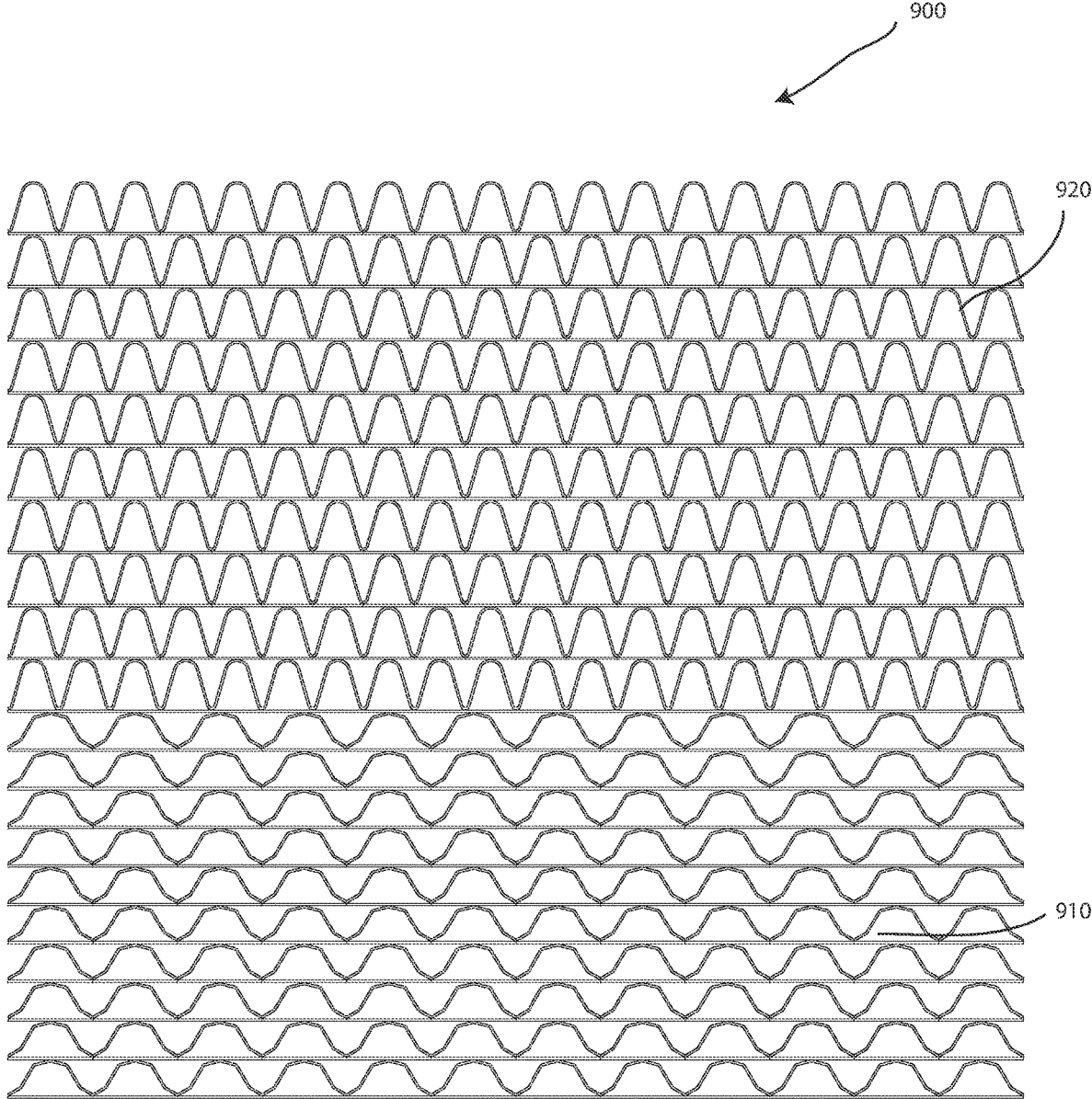

FIG. 9

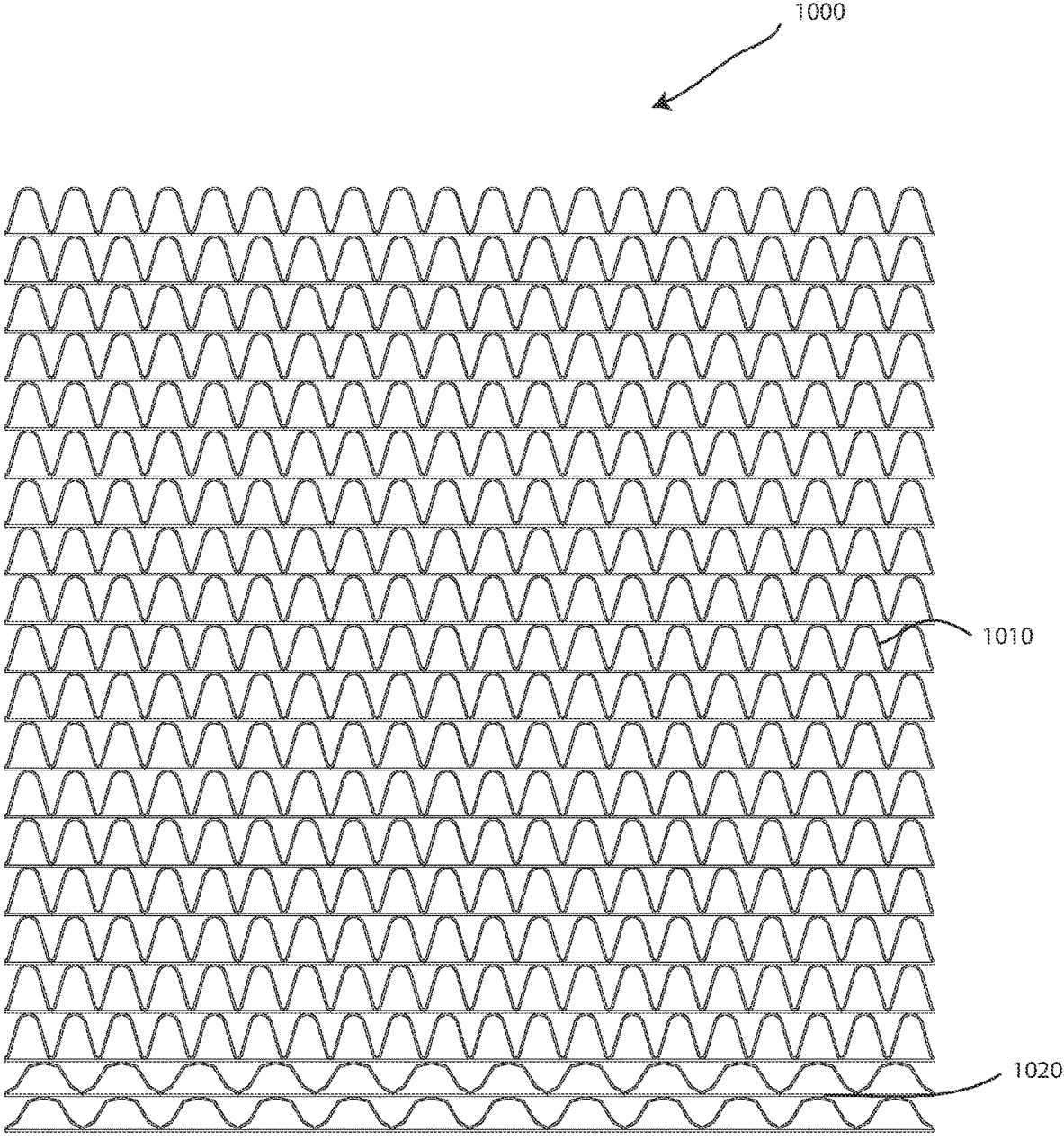

FIG. 10

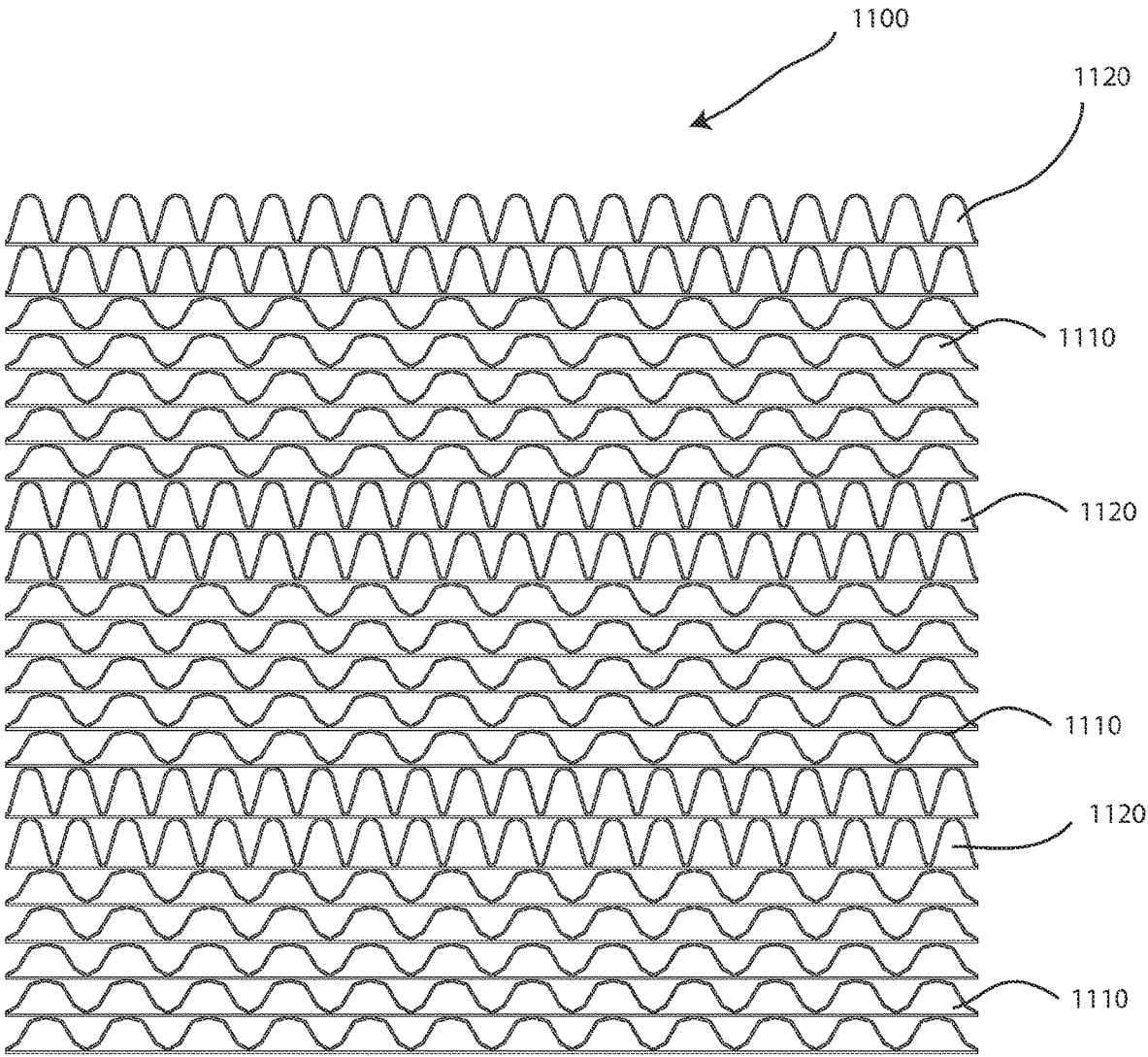

FIG. 11

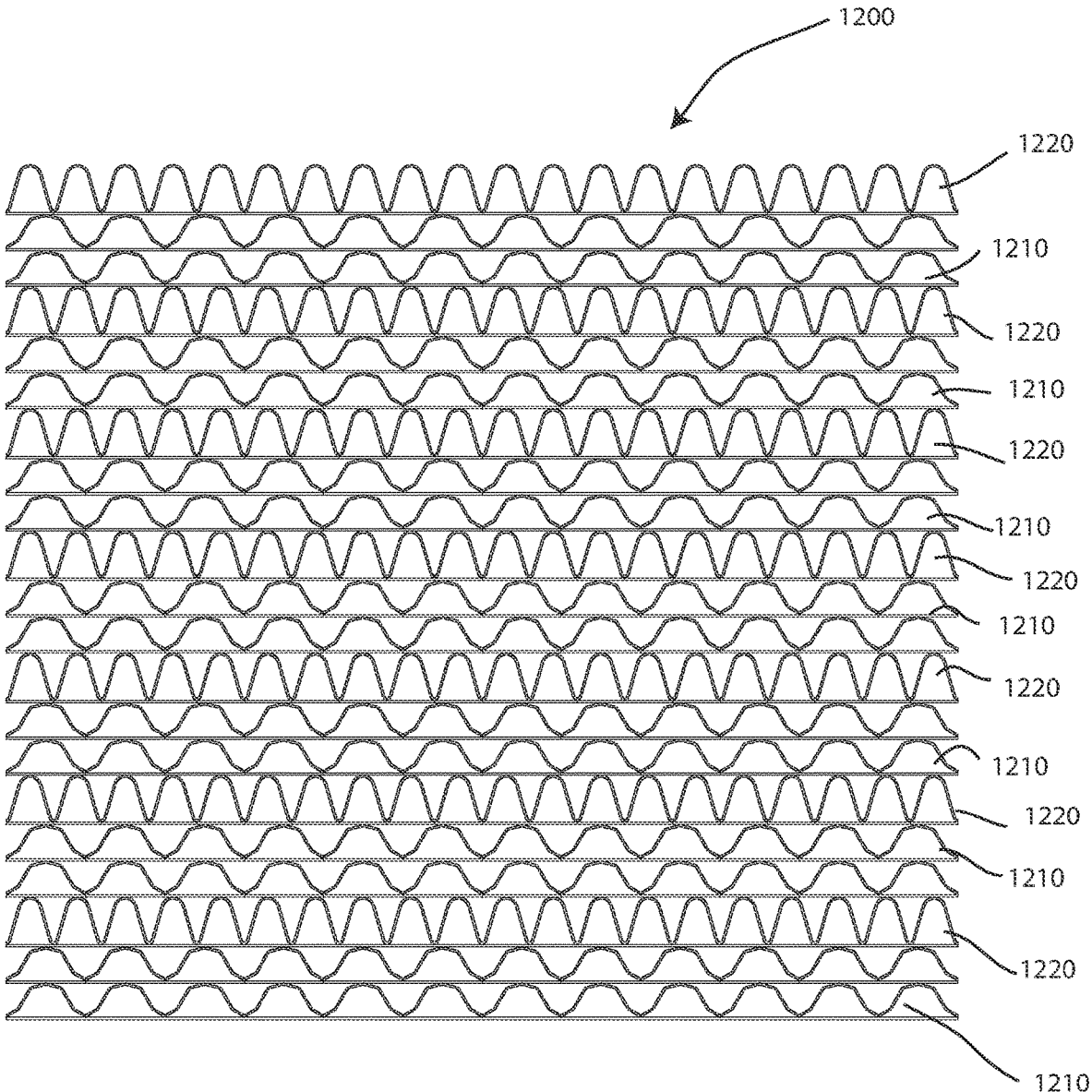

FIG. 12

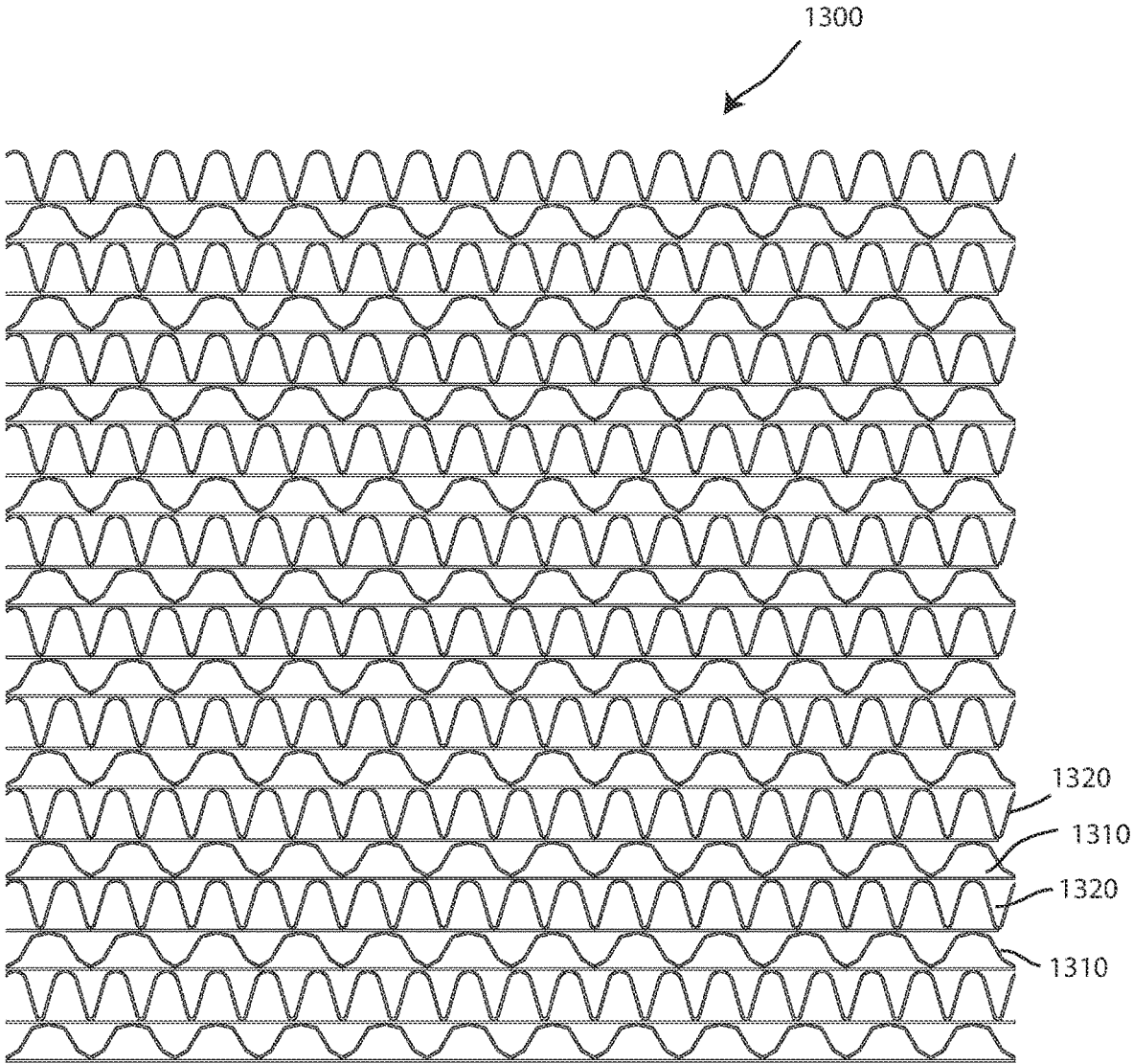

FIG. 13

1400

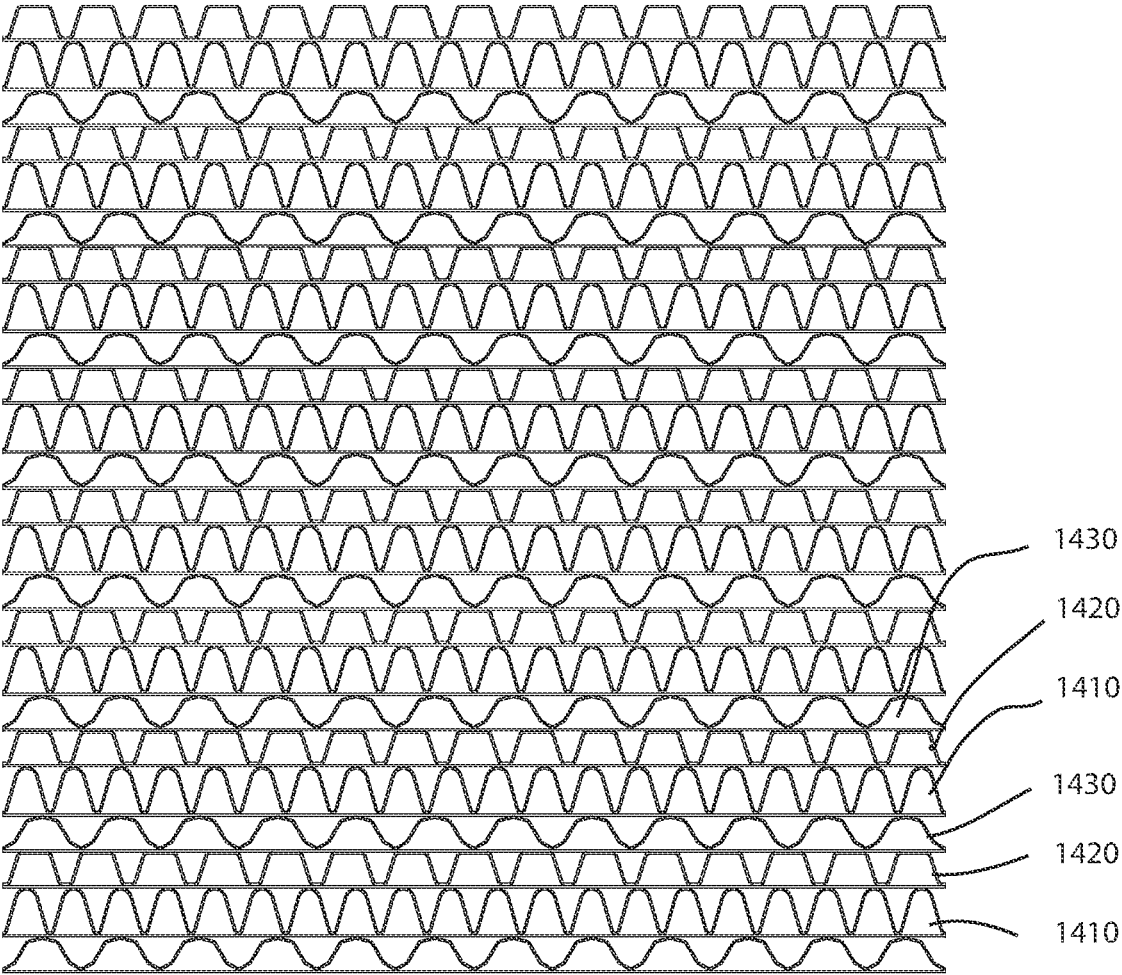

FIG. 14

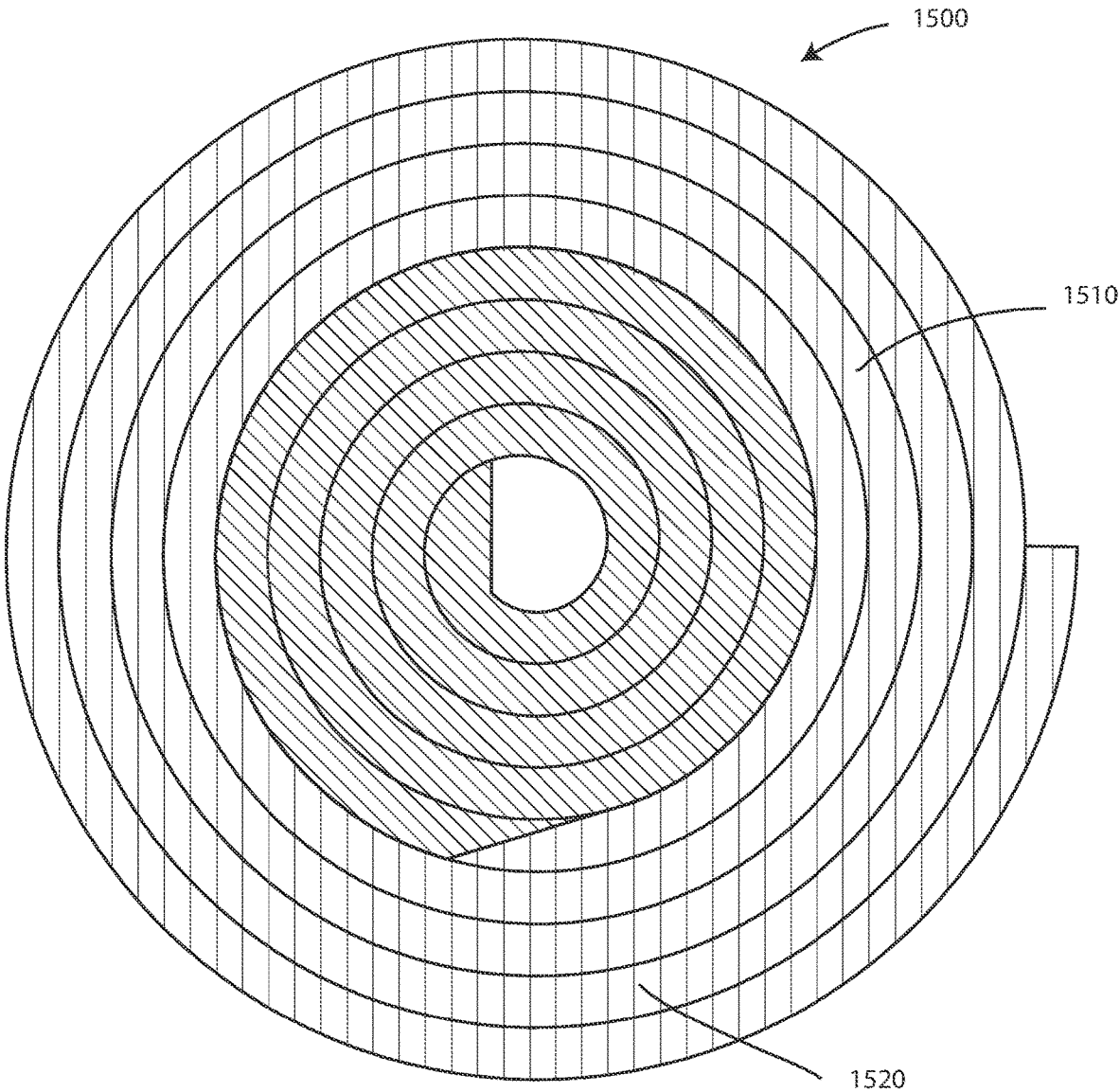

FIG. 15

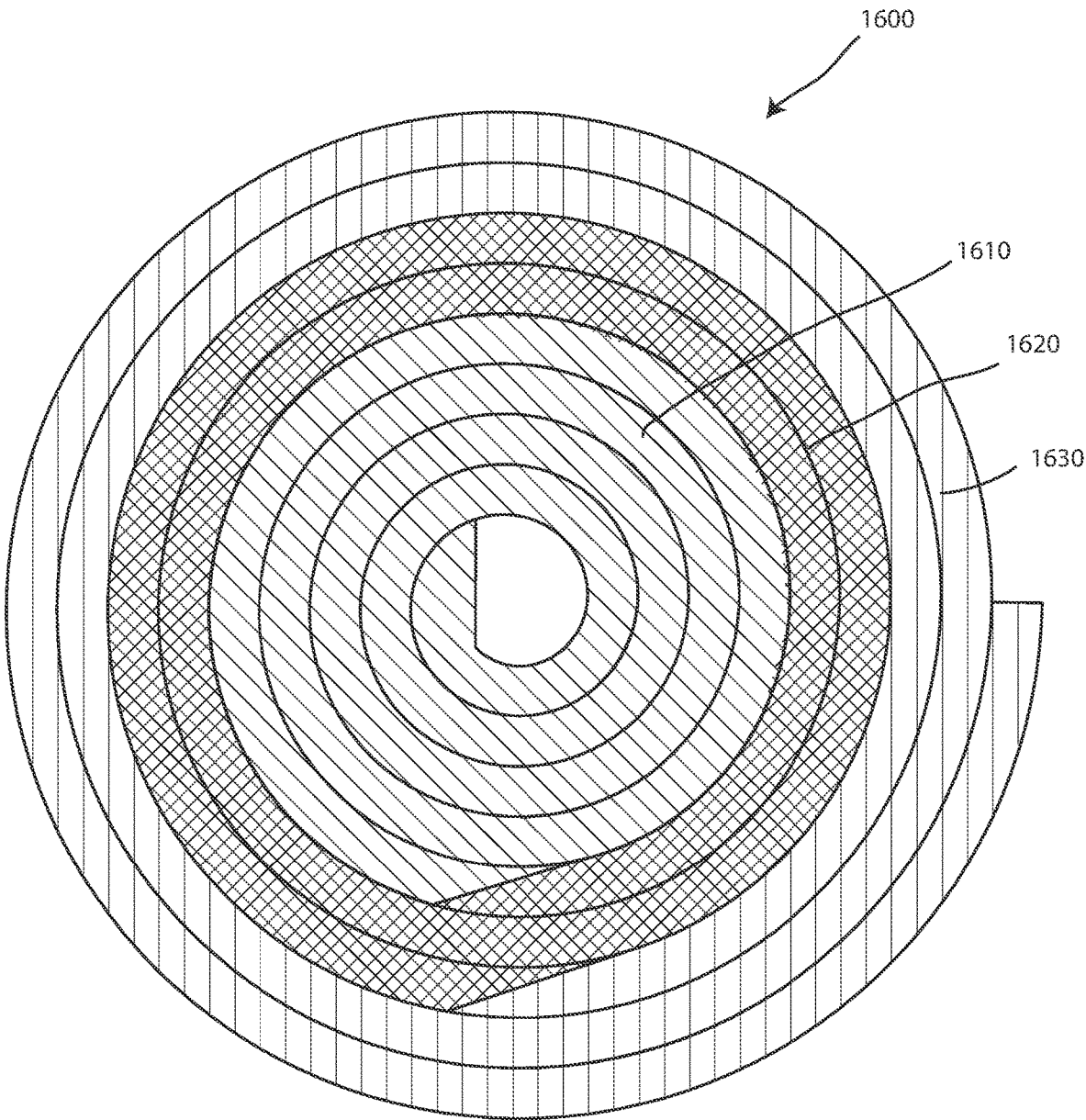

FIG. 16

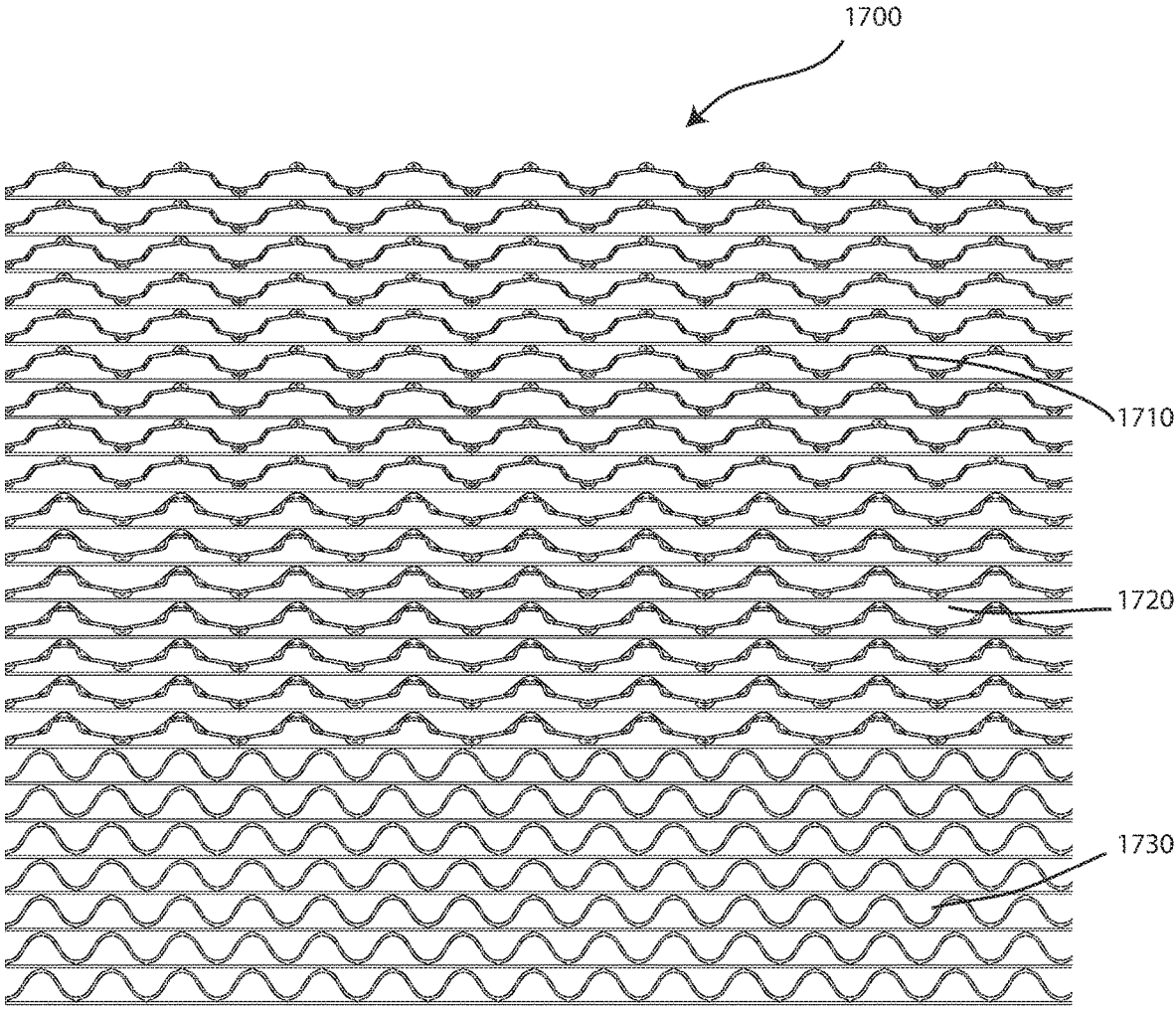

FIG. 17

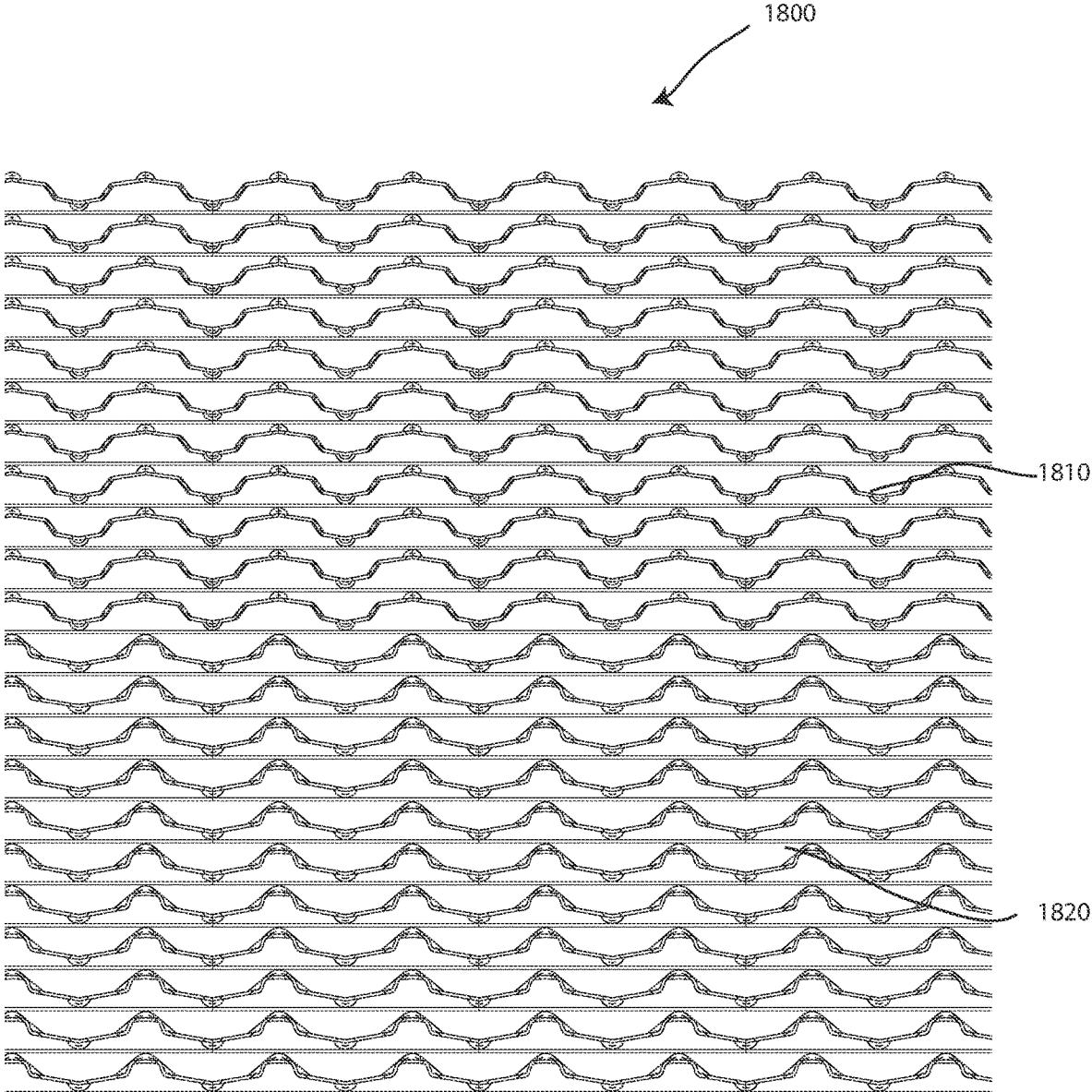

FIG. 18

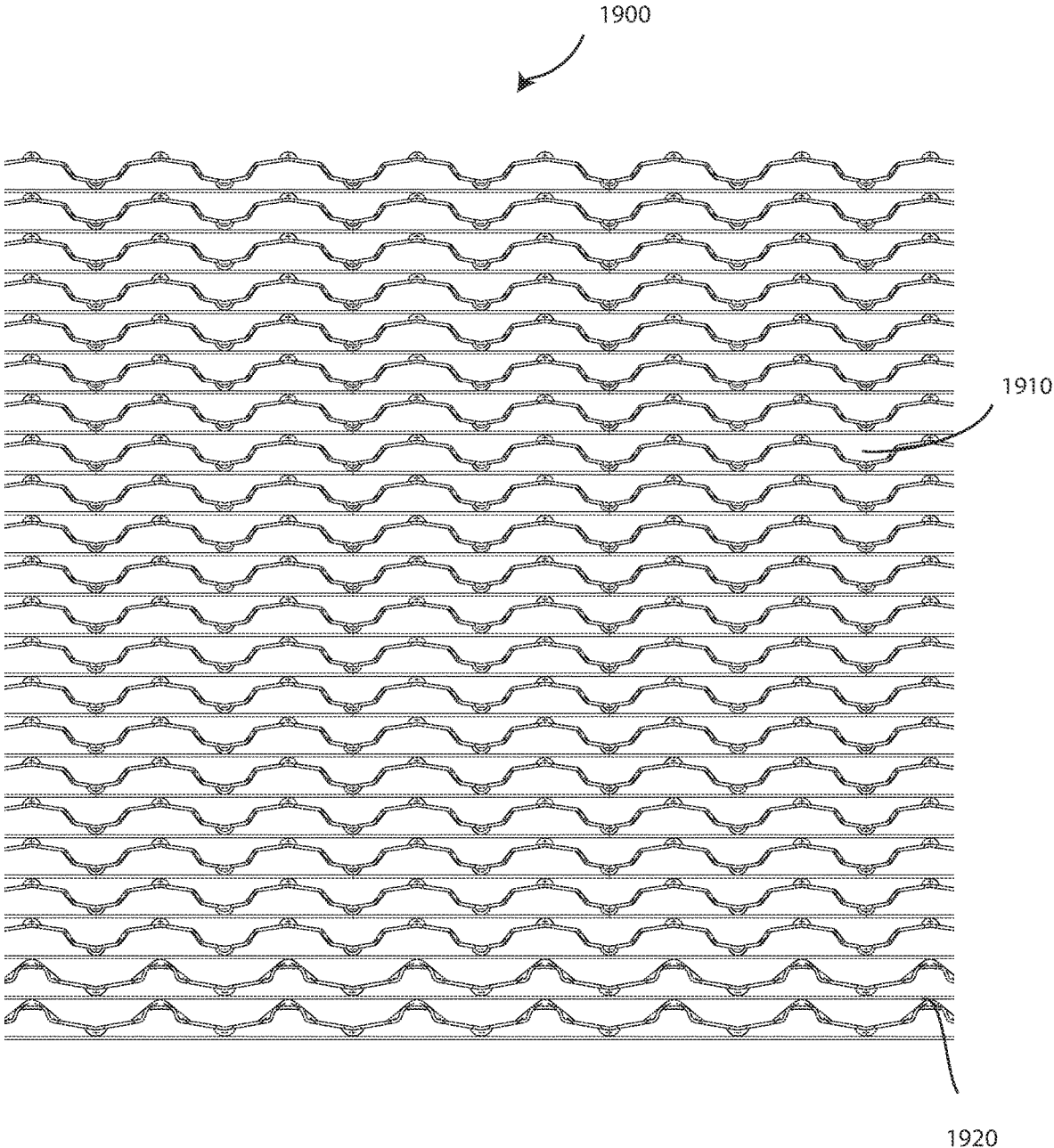

FIG. 19

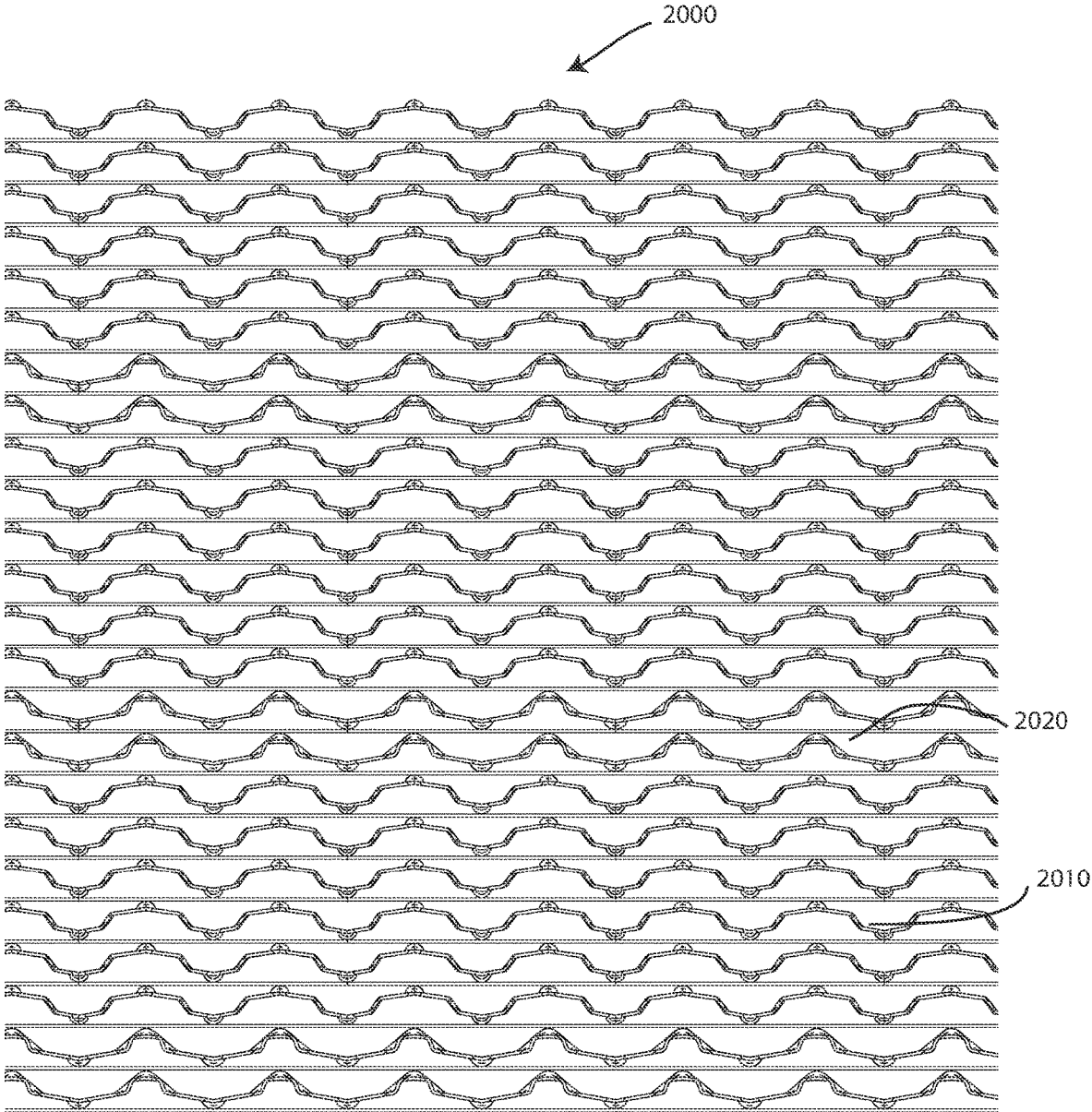

FIG. 20

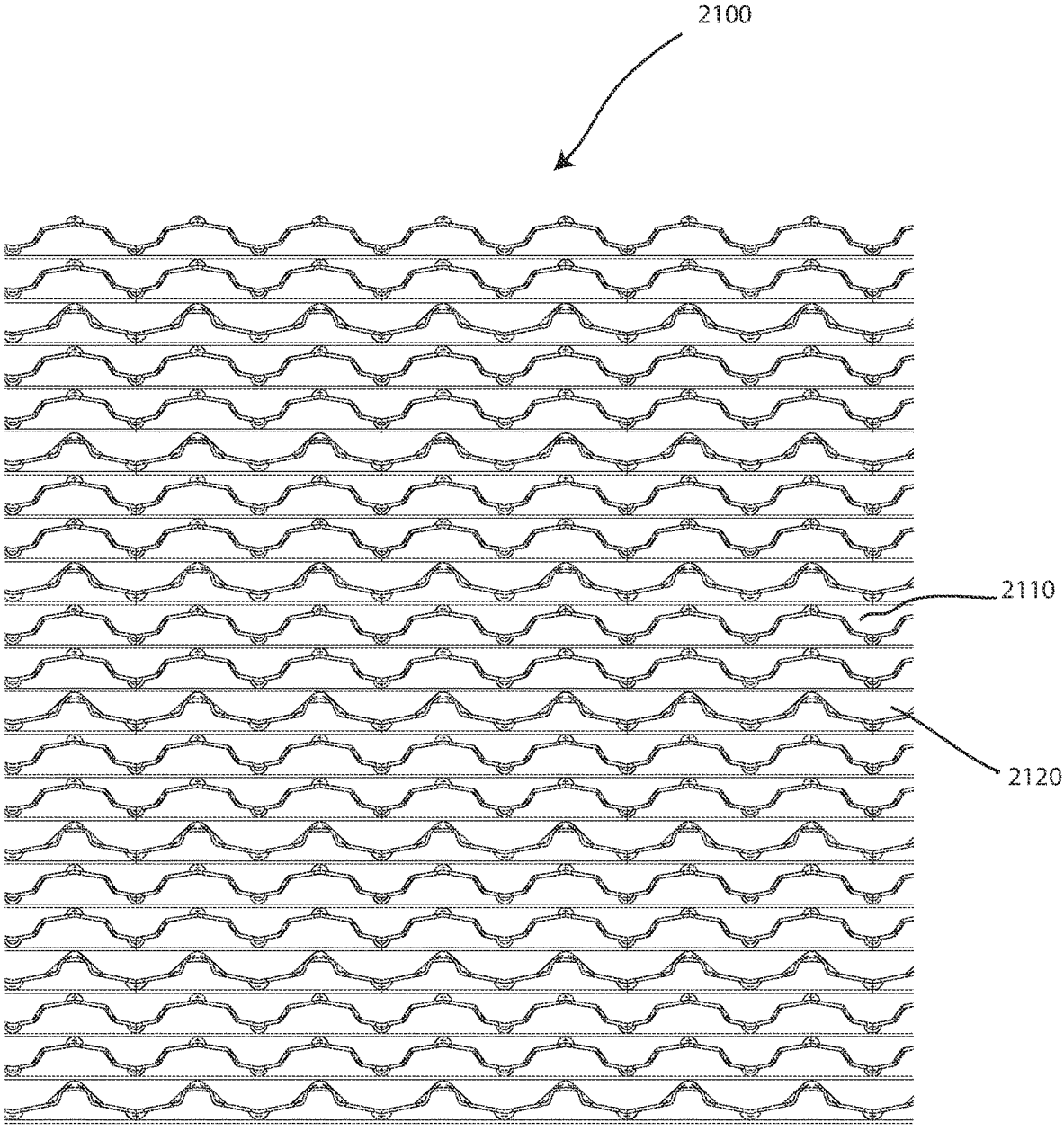

FIG. 21

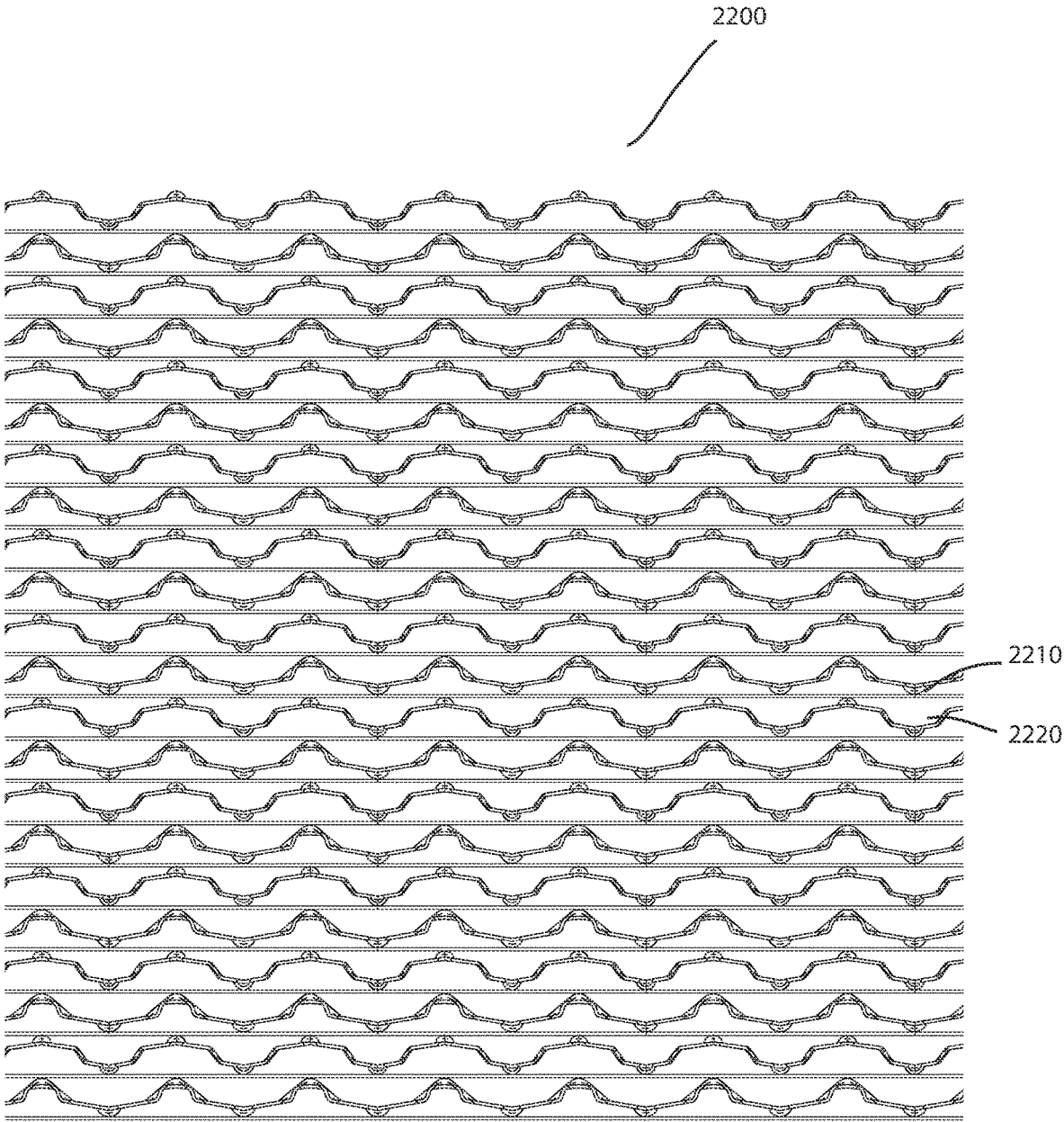

FIG. 22

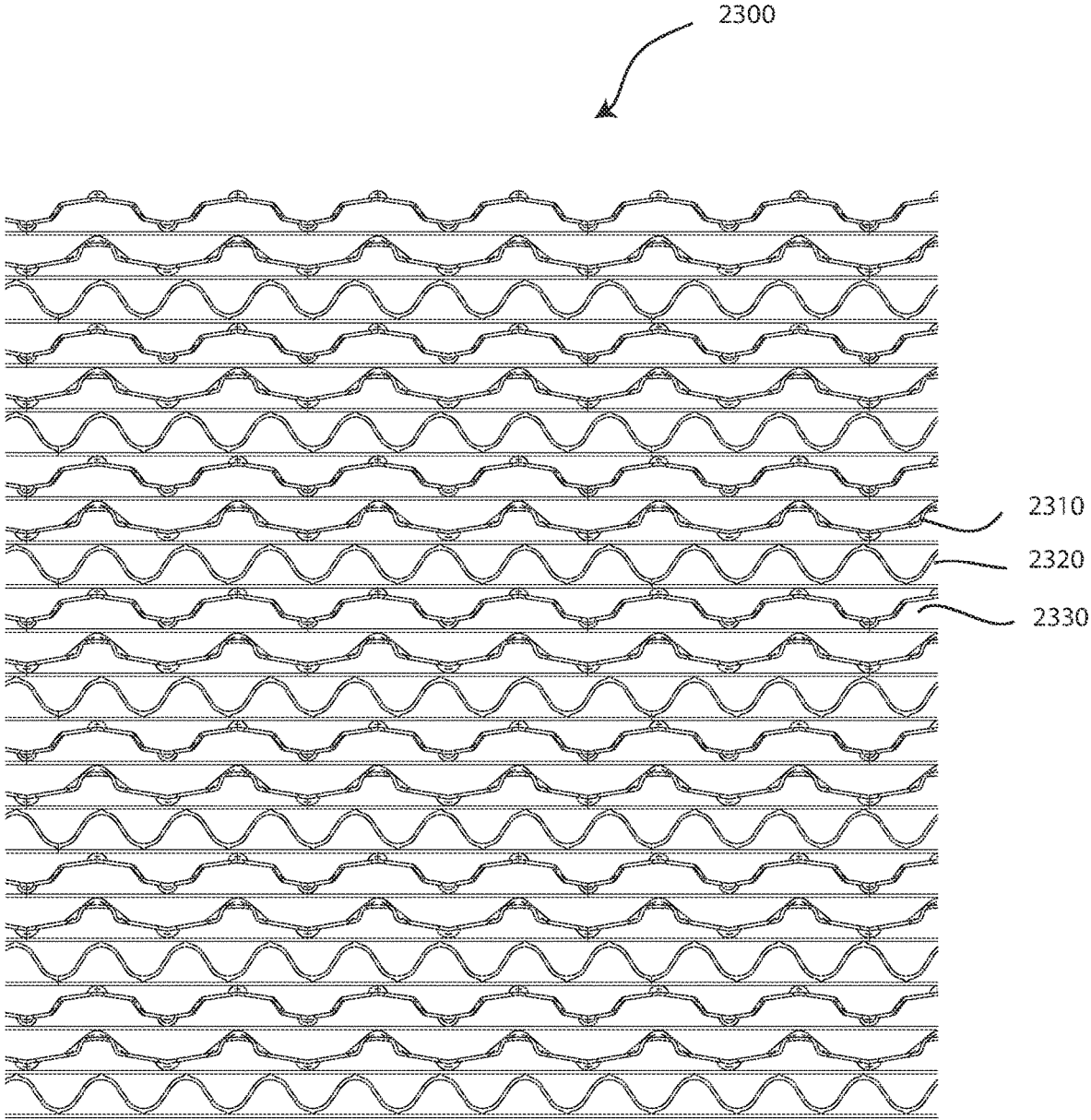

FIG. 23

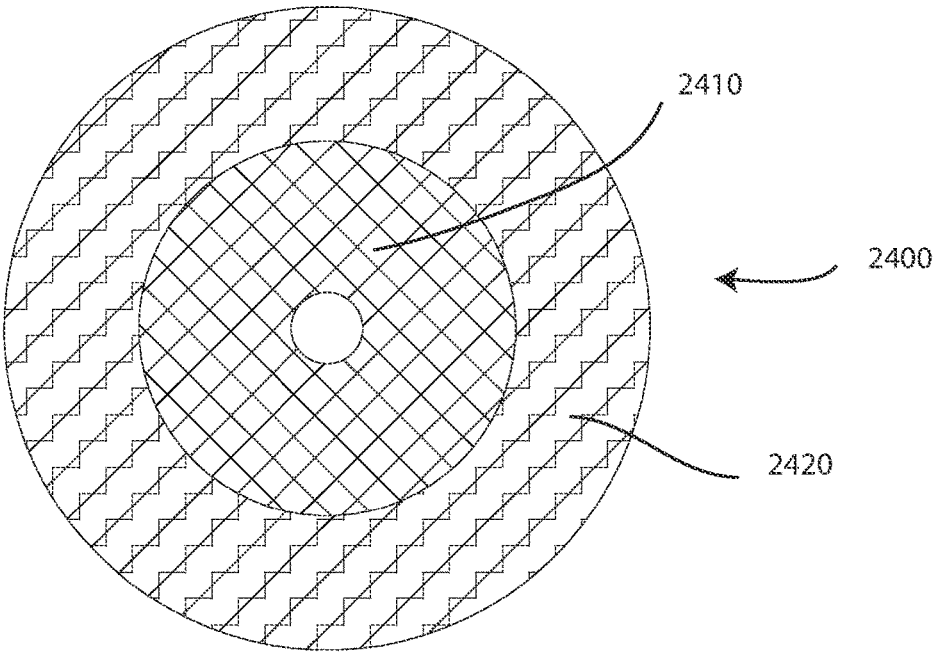

FIG. 24A

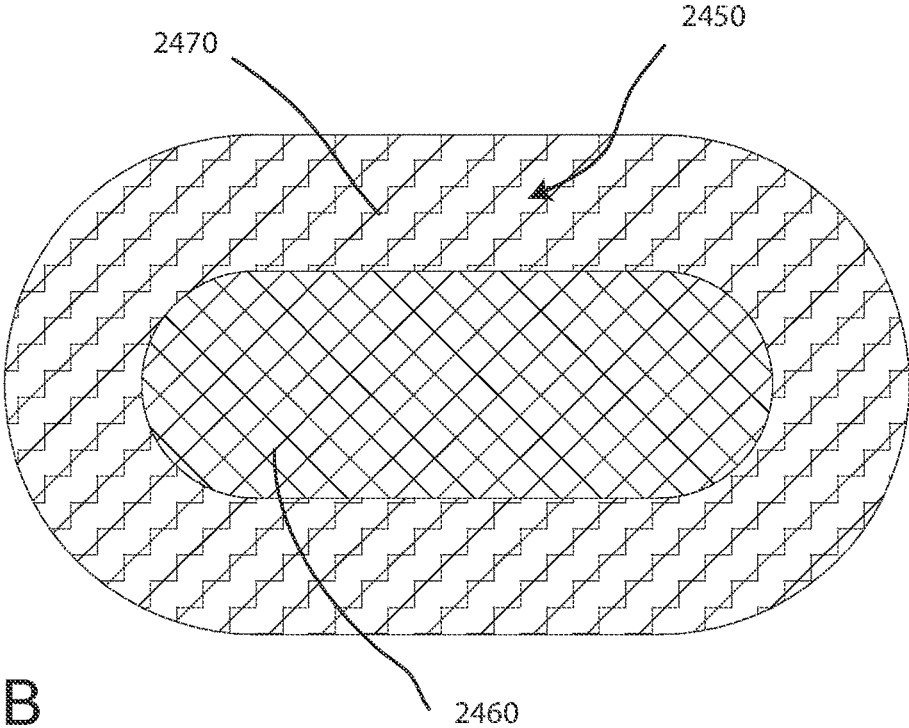

FIG. 24B

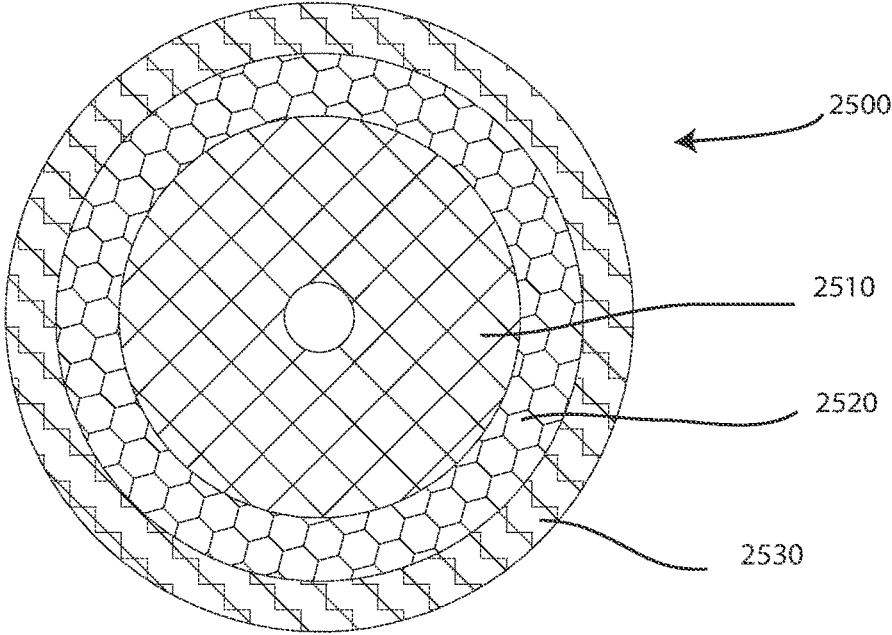

FIG. 25A

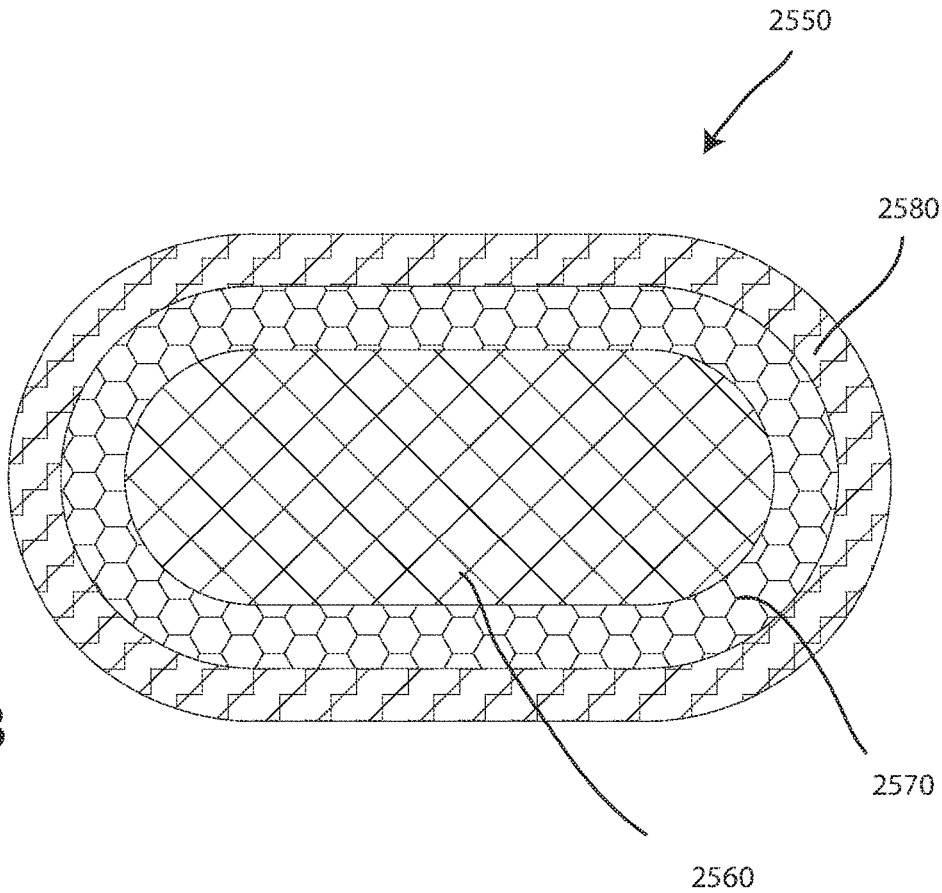

FIG. 25B

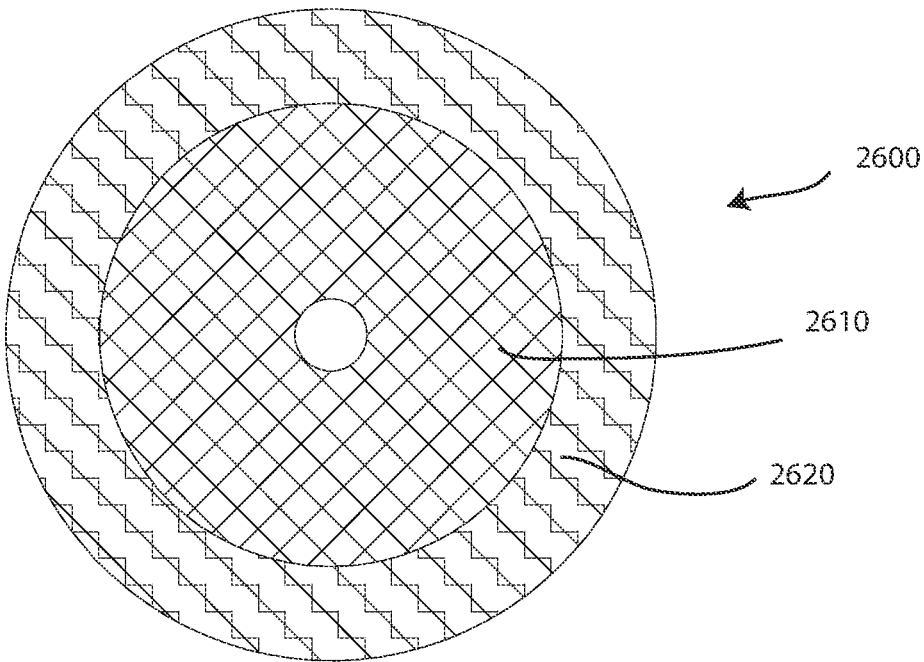

FIG. 26A

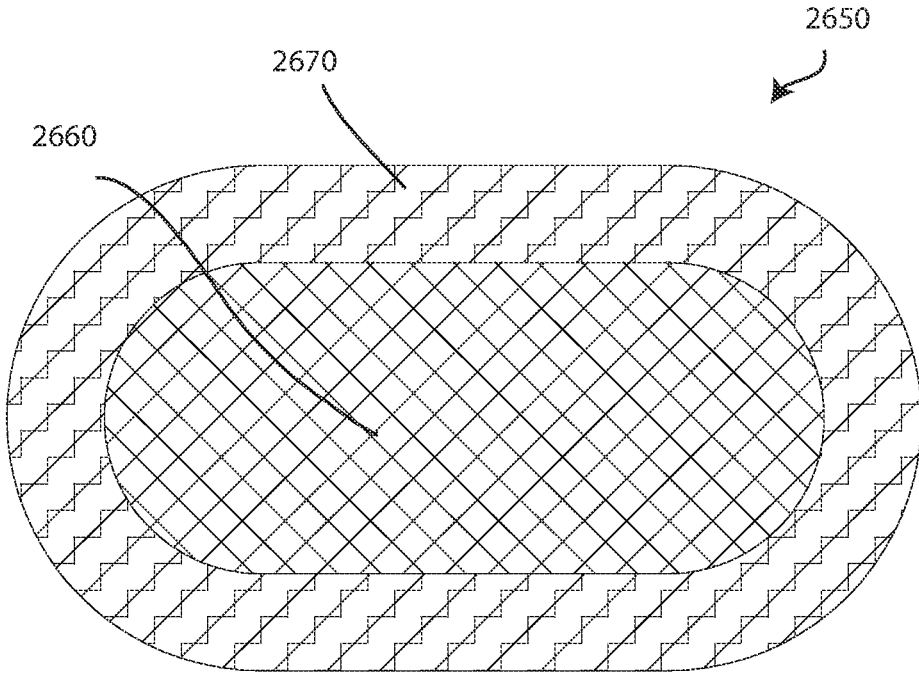
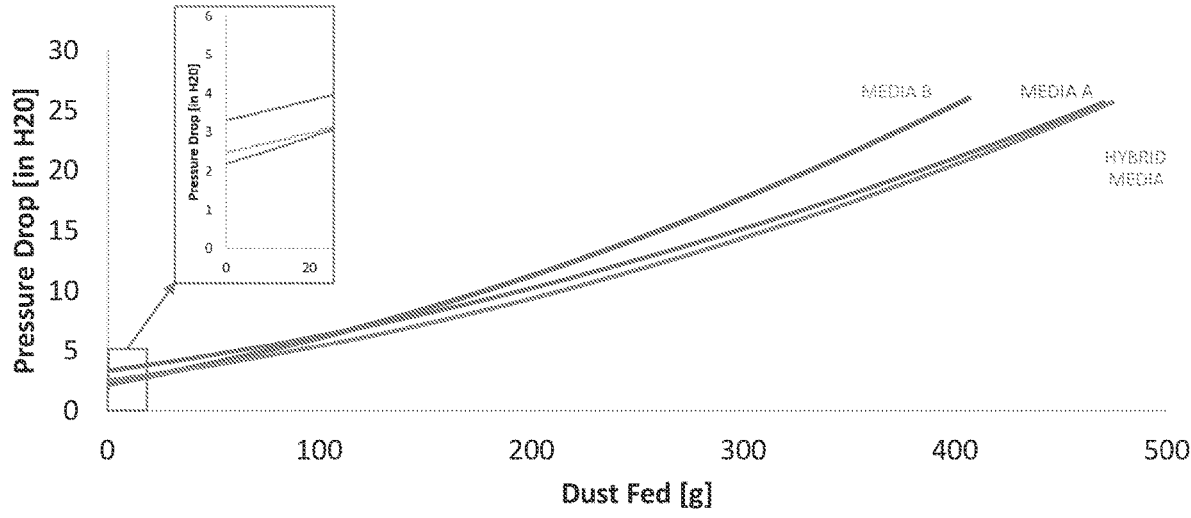

FIG. 26B

Figure 27
Loading Curve for Various Media



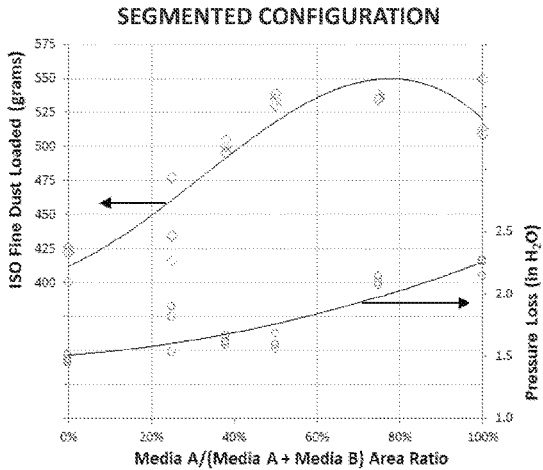

Figure 28A

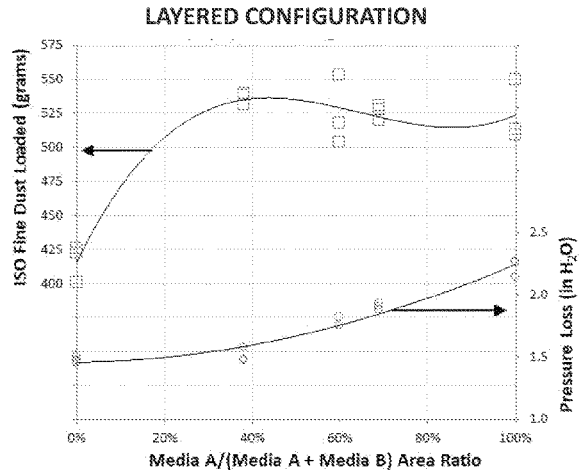

Figure 28B

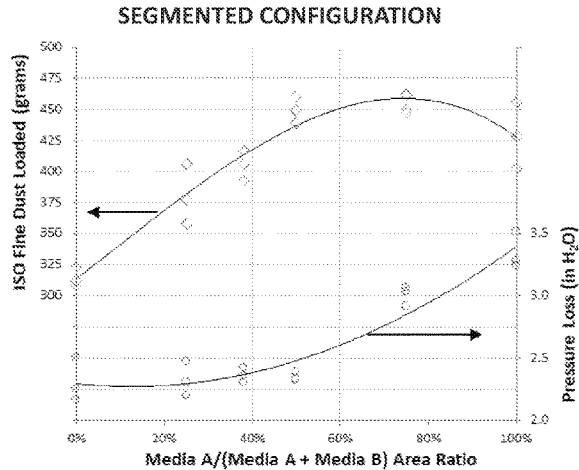

Figure 29A

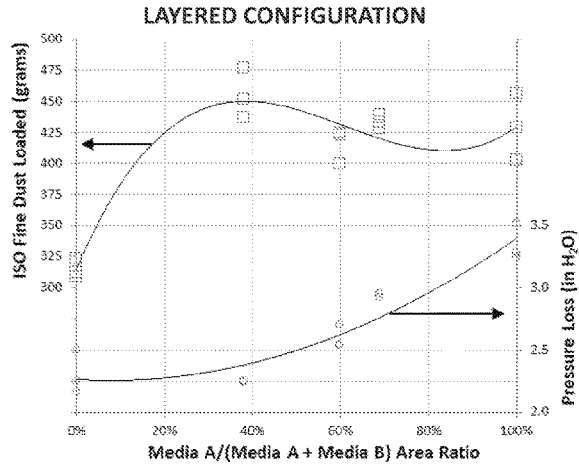

Figure 29B

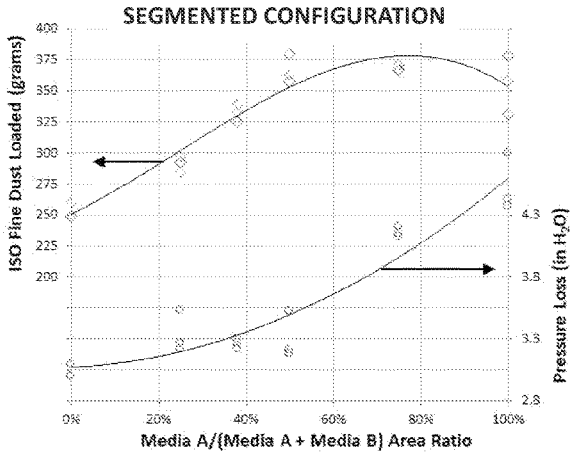

Figure 30A

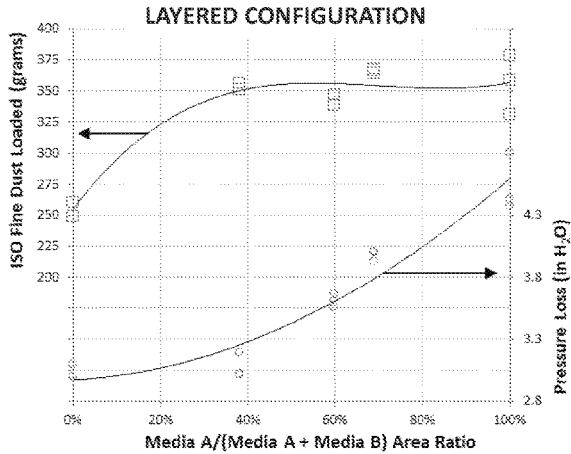

Figure 30B

FILTER MEDIA, FILTER MEDIA PACKS, AND FILTER ELEMENTS

[0001] This application is a continuation of U.S. patent application Ser. No. 16/438,183, filed Jun. 11, 2019, which claims the benefit of U.S. Provisional Application No. 62/683,542, filed Jun. 11, 2018, the content of which is herein incorporated by reference in its entirety.

FIELD

[0002] Embodiments herein relate to filter media, filter media packs, filter elements, air cleaners, and methods of making and using filter media, media packs, elements and air cleaners. More specifically, embodiments herein relate to z-flow filter media, media packs, and filter elements.

BACKGROUND

[0003] Z-flow filter media, such as that described in U.S. Pat. No. 7,959,702 to inventor Rocklitz, has a plurality of layers of media. Each layer has a fluted sheet, a facing sheet, and a plurality of flutes extending from a first face to a second face of the filtration media element. A first portion of the plurality of flutes are closed to unfiltered air flowing into the first portion of the plurality of flutes, and a second portion of the plurality of flutes are closed to unfiltered air from flowing out of the second portion of the plurality of flutes. Air passing into flutes on one face of the media element passes through filter media before flowing out flutes on the other face of the media element.

[0004] Although z-flow media has many benefits, a need remains for improved filter performance, including filter media, media packs, and elements with reduced pressure drop across the element and/or improved particulate loading capacity.

SUMMARY

[0005] The present application relates to filter media, filter media packs, filter elements, and air cleaners with two or more different media configurations, plus methods of making and using the media, media packs, filter elements, and air cleaners. The different media configurations can be, for example, different flute geometries in a z-flow filter media. The use of two or more different media configurations allows for improved performance, such as reduced pressure drop and/or increased loading capacity, relative to the use of a single media configuration.

[0006] In example implementations two different media sections are combined into a single filter element, the two media sections having distinct pressure drop and loading properties. The distinction in pressure drop and loading properties between the media sections will generally be less than normal variation observed within filter elements from manufacturing variations, thus generally the difference will be at least 5 percent for a specific measured and varied parameter, and more typically at least 10 percent for a specific measured and varied parameter. In an example configuration the first media section has a lower initial pressure drop than the second media section, while the second media section has a greater dust holding capacity than the first media section. In certain constructions the combination of these two media sections results in an element that has better performance than would be achieved with a media element made only of one of these media alone,

and better than would be achieved by just averaging the performance of each media sections. Thus, the hybrid filter element can (for example) demonstrate reduced initial pressure drop but also increased loading relative to media elements made with just one media or the other media.

[0007] An example embodiment is an air filtration element for removal of particulates from an airstream, the air filtration element comprising:

[0008] a) a first plurality of flutes; and

[0009] b) a second plurality of flutes arranged in a parallel flow configuration with the first plurality of flutes; the second plurality of flutes exhibiting differences in flute shape, flute size, flute height, flute width, flute length, cross-flute area, or filter media relative to the first plurality of flutes;

[0010] wherein the first plurality of flutes and second plurality of flutes have a common upstream and common downstream face; and

[0011] wherein when loading of the filter element with dust under substantially constant velocity, the first and second plurality of flutes perform as follows:

[0012] a) the first plurality of flutes and second plurality of flutes have substantially equal initial pressure drop from the upstream face to the downstream face;

[0013] b) the first plurality of flutes has an initial velocity greater than the initial velocity of the second plurality of flutes;

[0014] c) during dust loading:

[0015] i) the pressure drop across the first plurality of flutes and second plurality of flutes remains substantially equal relative to one another while the velocity of the first and second plurality of flutes is changing relative to one another; and

[0016] ii) the velocity across the first plurality of flutes decreases and the velocity across the second plurality of flutes increases at least until the velocity across the second plurality of flutes is greater than the velocity across the first plurality of flutes.

[0017] In an embodiment a transition from the velocity of the first plurality of flutes being greater than the second plurality of flutes to the velocity of the second plurality of flutes being greater than the first plurality of flutes occurs before the media element has loaded to 10 percent of dust loading capacity.

[0018] In an embodiment a transition from the velocity of the first plurality of flutes being greater than the second plurality of flutes to the velocity of the second plurality of flutes being greater than the first plurality of flutes occurs before the media element has loaded to 15 percent of dust loading capacity.

[0019] In an embodiment a transition from the velocity of the first plurality of flutes being greater than the second plurality of flutes to the velocity of the second plurality of flutes being greater than the first plurality of flutes occurs before the media element has loaded to 20 percent of dust loading capacity.

[0020] The initial pressure drop is meant to measure the first portion of media loading, such as less than 1 inch of water, less than 2 inches of water, or less than 3, 4, or 5 inches of water. The initial pressure drop can also be measured as the point to which an element reaches 1 percent of maximum pressure drop, 2 percent of maximum pressure drop, 5 percent of maximum pressure drop, or 10 percent of pressure drop (for example).

[0021] Flute height, for example, can be varied so that individual layers of media have varied height, multiple layers of media have different heights, or larger sections of media have different heights.

[0022] Flow through these various layers and sections of media is typically a parallel flow. As used herein, the term “parallel” refers to a construction in which a fluid stream to be filtered diverges into the first and second plurality of flutes, and then typically converges again later. As such, “parallel” does not require that the flutes themselves be arranged in a geometrically parallel configuration (although they often are), but rather that the pluralities of flutes exhibit parallel flow with regard to one another. Thus, “parallel” flow is used in contrast to “serial” flow (where the flow is from one plurality of flutes and then into a second plurality of flutes in serial flow).

[0023] Constructions made in accordance with the disclosures herein can, for example, allow for improvements in both pressure drop and dust loading relative to filter media elements and elements that are made of a single media type. In addition, in some implementations it is possible to add more media into a prescribed volume without significantly increasing initial pressure drop. As such, a media construction can be created that has a relatively low initial pressure drop while still having a relatively high dust loading capacity. This improvement can be obtained by combining a first media that has a low initial pressure drop (but low dust loading capacity) with a second media that has a higher initial pressure drop (and higher dust loading capacity). The resulting combined media demonstrates, in some embodiments, an initial pressure drop similar to the first media but with the dust loading of the second media.

[0024] It is also possible to utilize the benefits of the hybrid media constructions to get more media in a specific volume, as well as to load more dust on a given media surface area. Thus, it is possible to get improved media performance while having less media.

[0025] In an example embodiment, an air filtration element for removal of particulates from an airstream comprises: a) a first plurality of flutes; and b) a second plurality of flutes arranged in a parallel flow configuration with the first plurality of flutes; the second plurality of flutes exhibiting differences in flute shape, flute size, flute height, flute width, flute length, cross-flute area, or filter media relative to the first plurality of flutes; wherein the first plurality of flutes and second plurality of flutes have a common upstream and common downstream face; and wherein when loading of the filter element with dust under substantially constant velocity, the first and second plurality of flutes perform as follows:

[0026] a) the first plurality of flutes and second plurality of flutes have substantially equal initial pressure drop from the upstream face to the downstream face;

[0027] b) the first plurality of flutes has an initial velocity greater than the initial velocity of the second plurality of flutes;

[0028] c) during dust loading, as shown in FIG. 3A:

[0029] i) the pressure drop across the first plurality of flutes and second plurality of flutes remains substantially equal relative to one another while the velocity of the first and second plurality of flutes is changing relative to one another; and

[0030] ii) the velocity across the first plurality of flutes decreases and the velocity across the second plurality of flutes increases at least until the velocity

across the second plurality of flutes is greater than the velocity across the first plurality of flutes.

[0031] In an example implementation, an air filtration media element for removal of particulates from an airstream comprises a) a first plurality of flutes; and b) a second plurality of flutes arranged in a parallel flow configuration with the first plurality of flutes; the second plurality of flutes exhibiting differences in flute shape, flute size, flute height, flute width, cross-flute area, flute length, or filter media relative to the first plurality of flutes; wherein the first plurality of flutes and second plurality of flutes have a common upstream face and a common downstream face. When loading of the filter element with dust the first and second plurality of flutes performs as follows:

[0032] a) when the first and second plurality of flutes are tested independently at the same media element velocity, the first plurality of flutes has a lower initial pressure drop $\Delta P_{1,i}$ than the initial pressure drop $\Delta P_{2,i}$ across the second plurality of flutes; and the initial slope at time a of the pressure drop/loading curve of the first plurality of flutes $\Delta(\Delta P_{1,i}/L_{1,i})_a$ is greater than the initial slope of the pressure drop/loading curve of the second plurality of flutes $\Delta(\Delta P_{2,i}/L_{2,i})_a$:

$$\Delta(\Delta P_{1,i}/L_{1,i})_a > \Delta(\Delta P_{2,i}/L_{2,i})_a$$

[0033] b) when the first and second plurality of flutes are combined and simultaneously tested with parallel flow, the first plurality of flutes at time a has an initial velocity $V_{1,a}$ greater than the initial velocity $V_{2,a}$ of the second plurality of flutes at time a:

$$V_{1,a} > V_{2,a}$$

[0034] c) When the first and second plurality of flutes are combined and simultaneously tested with parallel flow, the first plurality of flutes has at a subsequent time b an intermediate second velocity $V_{1,b}$ equal to intermediate velocity $V_{2,b}$ of the second plurality of flutes:

$$V_{1,b} = V_{2,b}$$

[0035] d) When the first and second plurality of flutes are combined and simultaneously tested with parallel flow, the first plurality of flutes has at a subsequent time c a third velocity $V_{1,c}$ less than a third velocity $V_{2,c}$ of the second plurality of flutes:

$$V_{1,c} < V_{2,c}$$

[0036] In an example implementation, an air filtration element for removal of particulates from an airstream comprises: a) a first plurality of flutes; and b) a second plurality of flutes arranged in a parallel flow configuration with the first plurality of flutes; the second plurality of flutes exhibiting differences in flute shape, flute size, flute height, flute width, cross-flute area, flute length, or filter media relative to the first plurality of flutes; wherein the first plurality of flutes and second plurality of flutes have a common upstream and common downstream face. When simultaneous loading of dust under parallel flow conditions, and when loading to a point in which the media element has a pressure drop of at least 10 inches of water, the first and second plurality of flutes performs as follows:

[0037] a) the time average velocity of the first plurality of flutes \bar{V}_1 is less than the time average velocity of the entire filtration element \bar{V} element, and the time aver-

age velocity of the second plurality of flutes \bar{V}_2 is greater than the time average velocity of the filtration element $\bar{V}_{element}$:

$$\bar{V}_1 < \bar{V}_{element}$$

$$\bar{V}_2 > \bar{V}_{element}$$

[0038] b) the change in loading of the first plurality of flutes ΔL_1 is equal to the loading of the first plurality of flutes when tested at the first plurality of flutes time average velocity $L_{1,(V1\ avg)}$ minus the loading of the first plurality of flutes when tested at the element time average velocity $L_{1,(V\ element\ avg)}$:

$$\Delta L_1 = L_{1,(V1\ avg)} - L_{1,(V\ element\ avg)}$$

$$\Delta L_1 > 0$$

[0039] c) the change in loading of the second plurality of flutes ΔL_2 is equal to the loading of the second plurality of flutes when tested at the second plurality of flutes time average velocity $L_{2,(V2\ avg)}$ minus the loading of the second plurality of flutes when tested at the element time average velocity $L_{2,(V\ element\ avg)}$:

$$\Delta L_2 = L_{2,(V2\ avg)} - L_{2,(V\ element\ avg)}$$

$$\Delta L_2 < 0$$

[0040] d) the sum of ΔL_1 and ΔL_2 is greater than 0:

$$\Delta L_1 + \Delta L_2 > 0.$$

[0041] In an example implementation, an filtration media element for removal of particulates from an airstream comprises: a) a first plurality of flutes; and b) a second plurality of flutes arranged in a parallel flow configuration with the first plurality of flutes; the second plurality of flutes exhibiting differences in flute shape, flute size, flute height, flute width, flute length, cross-flute area, or filter media relative to the first plurality of flutes; wherein the first plurality of flutes and second plurality of flutes have a common upstream and common downstream face; and wherein the first and second plurality of flutes performs as follows:

[0042] i) the pressure drop ΔP increases as flow Q increases;

[0043] ii) before loading, when the first and second plurality of flutes are tested independently and at the same velocity, the first plurality of flutes has a lower initial pressure drop $\Delta P_{1,0}$ less than the initial pressure drop $\Delta P_{2,0}$ across the second plurality of flutes;

$$\Delta P_{1,0} < \Delta P_{2,0}$$

[0044] iii) when tested in parallel, the velocity of the first plurality of flutes before loading is greater than the average air filtration element velocity before loading, and the velocity of the second plurality of flutes before loading is less than the average air filtration media element velocity before loading;

$$V_{1,0} > V_{(element\ average),0}$$

$$V_{2,0} < V_{(element\ average),0}$$

[0045] v) when tested in parallel, the difference in pressure drop $\Delta(\Delta P_1)$ is equal to the pressure drop before loading of the first plurality of flutes tested at the first plurality of flutes velocity $\Delta P_{1,0,(V1,0)}$ minus the pressure drop before loading of the first plurality of

flutes when tested at the filtration element average velocity $\Delta P_{1,0,(V\ element\ avg),0}$:

$$\Delta(\Delta P_1) = \Delta P_{1,0,(V1,0)} - \Delta P_{1,0,(V\ element\ avg),0}$$

[0046] v) when tested in parallel, the difference in pressure drop $\Delta(\Delta P_2)$ of the second plurality of flutes is equal to the pressure drop before loading of the second plurality of flutes tested at the second plurality of flutes velocity $\Delta P_{2,0,(V2,0)}$ minus the pressure drop before loading of the second plurality of flutes when tested at the filtration element average velocity $\Delta P_{2,0,(V\ element\ avg),0}$:

$$\Delta(\Delta P_2) = \Delta P_{2,0,(V2,0)} - \Delta P_{2,0,(V\ element\ avg),0}$$

[0047] d) the sum of $\Delta(\Delta P_1)$ and $\Delta(\Delta P_2)$ is less than 0:

$$\Delta(\Delta P_1) + \Delta(\Delta P_2) < 0.$$

[0048] In example constructions the first media element can comprise, for example, approximately 10, 20, 30, 40, 50, 60, 70, 80, or 90 percent of the media element (measured by pack volume); and the second media element can comprise, for example, approximately 10, 20, 30, 40, 50, 60, 70, 80 or 90 percent of the media element (measured by pack volume). As used herein, pack volume means the total volume occupied by the media element when measuring that area contained within the perimeter of the pack. Thus, pack volume can include the media itself, as well as the open upstream volume into which dust can load and the downstream volume through which the filtered air travels out of the media element. Alternatively, the first plurality of flutes comprises from 20 to 40 percent of the pack volume, and the second plurality of flutes comprises from 60 to 80 percent of the pack volume. In other implementations the first plurality of flutes comprises from 40 to 60 percent of the pack volume, and the second plurality of flutes comprises from 60 to 40 percent of the pack volume. In yet another implementation the first plurality of flutes comprises from 60 to 90 percent of the inlet face of the media element, and the second plurality of flutes comprises from 40 to 10 percent of the pack volume.

[0049] In such example constructions the first media element can be, for example, approximately 10, 20, 30, 40, 50, 60, 70, 80, or 90 percent of the media element (measured by media surface area); and the second media can be, for example, approximately 10, 20, 30, 40, 50, 60, 70, 80 or 90 percent of the media element (measured by media surface area). As used herein, pack surface area means the total surface area of the media in each media element if the media element was taken apart and the media stretched out. Alternatively, the first plurality of flutes comprises from 20 to 40 percent of the media surface area, and the second plurality of flutes comprises from 60 to 80 percent of the media surface area. In other implementations the first plurality of flutes comprises from 40 to 60 percent of the inlet face of media surface area, and the second plurality of flutes comprises from 60 to 40 percent of the media surface area pack. In yet another implementation the first plurality of flutes comprises from 60 to 90 percent of the media surface area, and the second plurality of flutes comprises from 40 to 10 percent of the media surface area. It is also possible to characterize media elements by the portion of the inlet face occupied by a specific media type. In some implementations the first media element (comprising a first plurality of flutes) comprises from 10 to 90 percent of the inlet face of the media element, such as 10, 20, 30, 40, 50, 60, 70, 80 or 90

percent of the inlet face of the media element; and the second media element (comprising a second plurality of flutes) comprises from 90 to 10 percent of the inlet face of the media element, such as 90, 80, 70, 60, 50, 40, 30, 20 or 10 percent of the inlet face of the media element. Alternatively, the first plurality of flutes comprises from 20 to 40 percent of the inlet face of the media element, and the second plurality of flutes comprises from 60 to 80 percent of the inlet face of the media element. In other implementations the first plurality of flutes comprises from 40 to 60 percent of the inlet face of the media element, and the second plurality of flutes comprises from 60 to 40 percent of the inlet face of the media element. In yet another implementation the first plurality of flutes comprises from 60 to 90 percent of the inlet face of the media element, and the second plurality of flutes comprises from 40 to 10 percent of the inlet face of the media element.

[0050] Another embodiment of the filtration media element includes a third plurality of flutes arranged in parallel flow with the first and second plurality of flutes; wherein the first, second, and third plurality of flutes exhibit regular repeating differences in flute shape, flute size, flute height, flute width, cross-flute area, taper, or filter media. Optionally each of the first, second, and third pluralities of flutes is arranged in a separate plurality of layers. It will be understood that in some implementations more than three pluralities of flutes arranged in parallel flow, wherein each of the plurality of flutes exhibit differences in flute shape, flute size, flute height, flute width, cross-flute area, or filter media. Frequently these differences in flute properties are repeating, often regularly repeating.

[0051] In an example construction having three types of flutes, the first, second, and third flutes can be selected such that the first plurality of flutes comprises 20 to 50 percent of the volume of the media element, such as 20, 30, 40, or 50 percent the volume of media element; the second plurality of flutes comprises 20 to 50 percent the volume of the pack, such as 20, 30, 40 or 50 percent of the volume of media element; and the third plurality of flutes comprises 20 to 50 percent of the volume of the media element, such as 20, 30, 40 or 50 percent of the volume of the media element.

[0052] In an example construction having three types of flutes, the first, second, and third flutes can be selected such that the first plurality of flutes comprises 20 to 50 percent of the media surface area of the media element, such as 20, 30, 40, or 50 percent of the media surface area of the filter media element; the second plurality of flutes comprises 20 to 50 percent of the media surface area of the media element, such as 20, 30, 40 or 50 percent of the media surface area of the media element; and the third plurality of flutes comprises 20 to 50 percent of the media surface area of the media element, such as 20, 30, 40 or 50 percent of the surface area of the media element.

[0053] In an example construction having three types of flutes, the first, second, and third flutes can be selected such that the first plurality of flutes comprises 20 to 50 percent of the inlet face of the media element, such as 20, 30, 40, or 50 percent of the inlet face of the filter media element; the second plurality of flutes comprises 20 to 50 percent of the inlet face of the media element, such as 20, 30, 40 or 50 percent of the inlet face of the filter media element; and the third plurality of flutes comprises 20 to 50 percent of inlet face of the media element, such as 20, 30, 40 or 50 percent of the inlet face of the media element.

[0054] An example air filtration media element has a plurality of layers of fluted z-flow media. In some constructions each layer of media has a facing sheet and a fluted sheet. Each fluted sheet includes a plurality of flutes which exhibit regular repeating differences in flute shape, flute size, flute height, flute width, cross-flute area, or filter media. These pluralities of flutes are arranged and a parallel flow pattern. The facing sheet can be, for example, constructed of the same material forming the fluted sheet, or can be constructed of a different material. The facing sheet is typically not fluted but can be fluted in some constructions. The facing sheet can possess filtration properties or be a non-filtration material without filtration properties (such as a spacer material). Also, the facing sheet can cover all or only a portion of each fluted sheet. The facing sheet can be continuous or segmented such that separate facing sheet segments are positioned against each facing sheet.

[0055] The different media types in the plurality of flutes are in parallel flow to one another. As noted above, as used herein the term “parallel” refers to a construction in which a fluid stream to be filters diverges into the first and second plurality of flutes, and then typically converges again later. As such, “parallel” does not require that the flutes themselves be arranged in a geometrically parallel configuration (although they often are), but rather that the pluralities of flutes have generally parallel flow with regard to one another. Thus, “parallel” flow is used in contrast to “serial” flow where the flow is from one plurality of flutes and then into a second plurality of flutes. It will be understood that, in some constructions such as a wrapped construction, the fluid flow may be between adjacent sections of filter media.

[0056] Also, it will be understood that parallel flow can include media elements in which a plurality of flutes and second plurality of flutes have the same flute lengths or have different flute lengths as long as there is parallel flow. Similarly, there first plurality of flutes and second plurality of flutes can have a single front face and single rear face, can have front and rear faces that are flush with one another, or can have front and rear faces that are offset from one another. In some configurations the first and second plurality of flutes are separated from one another but still in parallel flow, and thus function as a single element.

[0057] The media can be arranged within a media element in a variety of constructions, including alternating single face layers (for example, construction A/B/C/A/B/C . . . where A, B, and C each refer to distinct flute types, and “/” denotes separate layers. Thus, A/B/C/A/B/C . . . refers to a fluted media with a first layer of flutes having configuration A, followed by second layer of flutes having configuration B, and third layer of flutes having configuration C. This order is repeated for layers four, five and six in the A/B/C/A/B/C arrangement. This A/B/C arrangement can be repeated numerous times to create the full media element.

[0058] The use of the terms “A”, “B”, and “C” flutes is meant to represent medias with different properties. For example, flutes of type A may have a greater height than flutes of type B or type C; or flutes of type B may have a greater or lesser width than flutes of type A or type C; or flutes of type A can be formed of media with greater efficiency and/or permeability than flutes of type B or C.

[0059] It will also be understood that the media can be arranged in constructions where layers of similar flutes are grouped together, such as a media element with the construction A/A/A/A/B/B/B/C/C/C. In this construction there

are four layers with A flutes, three layers with B flutes, and three layers with C flutes. Each of the layers with types of flutes A, B, and C are grouped together. The different media areas containing different types of flutes can directly contact one another, such as by being arranged in a stacked or wrap configuration. They also be arranged so that the different media areas are separated by a divider or other component.

[0060] It will also be understood that there can be many more than three or four layers of similar flutes grouped together depending upon flute size, media element size, etc. A media element may be constructed with many layers of each media, such as (for example), ten, twenty, thirty or forty grouped layers A flutes; or ten, twenty, thirty or forty grouped layers of B flutes, etc.

[0061] In some constructions flutes can be varied repeatedly within a layer as well as between layers. For example, a media element having the construction ABC . . . /DEF . . . /ABC . . . /DEF . . . /ABC . . . /DEF . . . has layers with repeating flutes A, flutes B and flutes C alternating with layers having flutes D, flutes E, and flutes F. Other examples, without limitation, include a media element with AB . . . /CDEF . . . /AB . . . /CDEF; a media element with A . . . /BCD . . . /A . . . /BCD

[0062] Using more than one flute configuration within a given filter media element or air cleaner can provide various benefits, including having a lower initial restriction of one flute configuration and the dust holding capacity of a second flute configuration. Thus, elements formed of the combined media can outperform elements formed solely of one flute configuration. In this manner combining different types and styles of flute geometries allows improvements in one or more of cost, initial pressure drop, loading capacity, or other aspects of filter performance.

[0063] In some constructions the relative position of the media is determined by desired element properties. For example, higher permeability media can be arranged in areas of a filter element that has highest face velocity due to configuration of an air cleaner in which it is placed so as to reduce initial restriction. In other embodiments, higher efficiency media is arranged in areas with the highest face velocity to improve initial efficiency of the filter element.

[0064] This summary is an overview of some of the teachings of the present application and is not intended to be an exclusive or exhaustive treatment of the present subject matter. Further details are found in the detailed description and appended claims. Other aspects will be apparent to persons skilled in the art upon reading and understanding the following detailed description and viewing the drawings that form a part thereof, each of which is not to be taken in a limiting sense. The scope herein is defined by the appended claims and their legal equivalents.

BRIEF DESCRIPTION OF THE FIGURES

[0065] Aspects may be more completely understood in connection with the following figures, in which

[0066] FIG. 1 is perspective view of an example filter element made in accordance with example embodiment.

[0067] FIG. 2A is an enlarged schematic, cross-sectional view of a section of filter media.

[0068] FIG. 2B is a partial, enlarged cross-sectional view of a sheet of fluted media along with top and bottom facing sheets.

[0069] FIG. 3A to 3F are schematic representations of the performance of elements (these figures are representational, and not based upon actual measured test data)

[0070] FIG. 4A is a top schematic view of an example filter media element, showing a wound configuration with two types of filter media.

[0071] FIG. 4B is a top schematic view of an example filter media element, showing a wound configuration with three types of filter media.

[0072] FIG. 5 is a top schematic view of an example filter media element, showing a stacked configuration of filter media.

[0073] FIG. 6 is a top schematic view of an example filter media element, showing a stacked configuration of filter media.

[0074] FIG. 7 is a top schematic view of an example filter media element, showing a stacked configuration of filter media.

[0075] FIG. 8 is a top schematic view of an example filter media element, showing a stacked configuration with three types of filter media.

[0076] FIG. 9 is a top schematic view of an example filter media element, showing a stacked configuration with two types of filter media.

[0077] FIG. 10 is a top schematic view of an example filter media element, showing a stacked configuration with two types of filter media.

[0078] FIG. 11 is a top schematic view of an example filter media element, showing a stacked configuration with two types of filter media.

[0079] FIG. 12 is a top schematic view of an example filter media element, showing a stacked configuration with two types of filter media.

[0080] FIG. 13 is a top schematic view of an example filter media element, showing a stacked configuration with two types of filter media.

[0081] FIG. 14 is a top schematic view of an example filter media element, showing a stacked configuration with three types of filter media.

[0082] FIG. 15 is a top schematic view of an example filter media element, showing a wound configuration with two types of filter media.

[0083] FIG. 16 is a top schematic view of an example filter media element, showing a wound configuration with three types of filter media.

[0084] FIG. 17 is a top schematic view of an example filter media element, showing a stacked configuration with three types of filter media.

[0085] FIG. 18 is a top schematic view of an example filter media element, showing a stacked configuration with two types of filter media.

[0086] FIG. 19 is a top schematic view of an example filter media element, showing a stacked configuration with two types of filter media.

[0087] FIG. 20 is a top schematic view of an example filter media element, showing a stacked configuration with two types of filter media.

[0088] FIG. 21 is a top schematic view of an example filter media element, showing a stacked configuration with two types of filter media.

[0089] FIG. 22 is a top schematic view of an example filter media element, showing a stacked configuration with two types of filter media.

[0090] FIG. 23 is a top schematic view of an example filter media element, showing a stacked configuration with three types of filter media.

[0091] FIG. 24A is a top schematic view of an example filter media element, showing a wound configuration with two types of filter media.

[0092] FIG. 24B is a top schematic view of an example filter media element, showing a wound configuration with two types of filter media.

[0093] FIG. 25A is a top schematic view of an example filter media element, showing a wound configuration with three types of filter media.

[0094] FIG. 25B is a top schematic view of an example filter media element, showing a wound configuration with three types of filter media.

[0095] FIG. 26A is a top schematic view of an example filter media element, showing a wound configuration with two types of filter media.

[0096] FIG. 26B is a top schematic view of an example filter media element, showing a wound configuration with two types of filter media.

[0097] FIG. 27 shows performance results from comparative testing of filter elements with different media types.

[0098] FIGS. 28A and 28B show performance results, including dust loading and pressure drop, for various media constructions

[0099] FIGS. 29A and 29B show performance results, including dust loading and pressure drop, for various media constructions

[0100] FIGS. 30A and 30B show performance results, including dust loading and pressure drop, for various media constructions

[0101] While embodiments are susceptible to various modifications and alternative forms, specifics thereof have been shown by way of example and drawings, and will be described in detail. It should be understood, however, that the scope herein is not limited to the embodiments described. On the contrary, the intention is to cover modifications, equivalents, and alternatives falling within the spirit and scope herein.

DETAILED DESCRIPTION

[0102] The present application is directed, in an example embodiment, to an air filtration media element comprising a plurality of layers of fluted media, each layer comprising a first plurality of flutes and a second plurality of flutes, the first and second plurality of flutes being arranged in a parallel flow configuration; wherein the first and second plurality of flutes exhibit differences in flute shape, flute size, flute height, flute width, flute length, cross-flute area, or filter media. In example embodiments the differences are differences in taper of the flutes of the first and second plurality.

[0103] These pluralities of flutes are arranged in parallel flow. As noted above, as used in this context, the term “parallel” refers to a construction in which a fluid stream to be filtered diverges into the first and second plurality of flutes, and then typically converges again later. As such, “parallel” does not require that the flutes themselves be arranged in a geometrically parallel configuration (although they often are), but rather that the pluralities of flutes exhibit parallel flow with regard to one another. Thus, “parallel” flow is used in contrast to “serial” flow (where the flow is from one plurality of flutes and then into a second plurality of flutes in serial flow).

[0104] In some implementations filtration media element can be constructed so that the first and second plurality of flutes are arranged together within at least one layer of the fluted media. In other implementations the first plurality of flutes is arranged in a first plurality of layers, and the second plurality of flutes is arranged in a second plurality of layers of the fluted media. These two constructions can also be combined so that individual layers have repeating differences among the flutes, and that different layers are combined.

[0105] An example embodiment is an air filtration element for removal of particulates from an airstream, the air filtration element comprising:

[0106] a) a first plurality of flutes; and

[0107] b) a second plurality of flutes arranged in a parallel flow configuration with the first plurality of flutes; the second plurality of flutes exhibiting differences in flute shape, flute size, flute height, flute width, flute length, cross-flute area, or filter media relative to the first plurality of flutes;

[0108] wherein the first plurality of flutes and second plurality of flutes have a common upstream and common downstream face; and

[0109] wherein when loading of the filter element with dust under substantially constant velocity, the first and second plurality of flutes perform as follows:

[0110] a) the first plurality of flutes and second plurality of flutes have substantially equal initial pressure drop from the upstream face to the downstream face;

[0111] b) the first plurality of flutes has an initial velocity greater than the initial velocity of the second plurality of flutes;

[0112] c) during dust loading:

[0113] i) the pressure drop across the first plurality of flutes and second plurality of flutes remains substantially equal relative to one another while the velocity of the first and second plurality of flutes is changing relative to one another; and

[0114] ii) the velocity across the first plurality of flutes decreases and the velocity across the second plurality of flutes increases at least until the velocity across the second plurality of flutes is greater than the velocity across the first plurality of flutes.

[0115] In an embodiment a transition from the velocity of the first plurality of flutes being greater than the second plurality of flutes to the velocity of the second plurality of flutes being greater than the first plurality of flutes occurs before the media element has loaded to 10 percent of dust loading capacity.

[0116] In an embodiment a transition from the velocity of the first plurality of flutes being greater than the second plurality of flutes to the velocity of the second plurality of flutes being greater than the first plurality of flutes occurs before the media element has loaded to 15 percent of dust loading capacity.

[0117] In an embodiment a transition from the velocity of the first plurality of flutes being greater than the second plurality of flutes to the velocity of the second plurality of flutes being greater than the first plurality of flutes occurs before the media element has loaded to 20 percent of dust loading capacity.

[0118] In example implementations two different media elements are combined into a single filter element, the two media elements having distinct pressure drop and loading

properties. In an example the first media element has a lower initial pressure drop than the second media element, while the second media element has a greater dust holding capacity than the first media element. In certain constructions the combination of these two media results in an element that has better performance than would be achieved with either media alone, and better than would be achieved by just averaging the performance of each media element. Thus, the hybrid filter element can (for example) demonstrate reduced initial pressure flow but also increased loading.

[0119] In an example implementation, an air filtration media element for removal of particulates from an airstream comprises a first plurality of flutes; and a second plurality of flutes arranged in a parallel flow configuration with the first plurality of flutes; the second plurality of flutes exhibiting differences in flute shape, flute size, flute height, flute width, flute length, cross-flute area, or filter media relative to the first plurality of flutes. The first plurality of flutes and second plurality of flutes have a common upstream and common downstream face; and when loading of dust under substantially constant velocity, the first and second plurality of flutes perform as follows: a) the first plurality of flutes and second plurality of flutes have substantially equal initial pressure drop from the upstream face to the downstream face; b) the first plurality of flutes has an initial velocity greater than the initial velocity of the second plurality of flutes; c) during dust loading: i) the velocity across the first plurality of flutes decreases and the velocity across the second plurality of flutes increases at least until the velocity across the second plurality of flutes is greater than the velocity across the first plurality of flutes; and ii) the pressure drop across the first plurality of flutes and second plurality of flutes remains substantially equal relative to one another while the velocity of the first and second plurality of flutes is changing relative to one another.

[0120] Velocity is volumetric flow rate/element volume. Examples of velocity ranges from for example, 300 to 3000 cfm/cubic foot. In some implementations velocity ranges from 500 to 2000 cfm/cubic foot. In certain embodiments velocity is greater than 300, greater than 500, greater than 1000, or greater than 2000 cfm/cubic foot. In certain embodiments velocity is less than 3000, less than 2000, less than 1000, or less than 500 cfm/cubic foot.

[0121] Flow through the elements can be, for example, 200 to 3000 cubic feet per minute (cfm). In some implementations flow is greater than 200, greater than 500, greater than 1000, greater than 1500, greater than 2000, or greater than 2500 cfm. In some implementations the flow is less than 3000, less than 2500, less than 2000, less than 1500, less than 1000, or less than 500 cfm.

[0122] Restriction at terminal for the elements can be, for example, 10 to 40 inches of water. In some implementations restriction at terminal is greater than 10, greater than 15, greater than 20, greater than 25, greater than 30, or greater than 35 inches of water. In some implementations restriction at terminal is less than 40, less than 35, less than 30, less than 25, less than 20, or less than 15 inches of water.

[0123] Restriction rise to terminal can be, for example, 5 to 35 inches of water. In some implementations restriction rise to terminal can be greater than 5, greater than 10, greater than 15, greater than 20, greater than 25, greater than 30, or greater than 35 inches of water. In some implementations

restriction rise to terminal is less than 40, less than 35, less than 30, less than 25, less than 20, or less than 15 inches of water.

[0124] In example constructions the first media element can be, for example, approximately 20, 30, 40, or 50 percent of the media element (measured by pack volume); and the second media element can be, for example, approximately 20, 30, 40, or 50 percent of the media element (measured by pack volume). As used herein, pack volume means the total volume occupied by the media element when measuring that area contained within the perimeter of the pack. Thus, pack volume can include the media itself, as well as the open volume into which dust can load.

[0125] In such example constructions the first media element can be, for example, approximately 20, 30, 40, or 50 percent of the media element (measured by media surface area); and the second media element can be, for example, approximately 20, 30, 40, or 50 percent of the media element (measured by media surface area). As used herein, pack surface area means the total surface area of the media in each media element if the media element was taken apart and the media stretched out.

[0126] In some implementations the first plurality of flutes comprises from 10 to 90 percent of the inlet face of the media element, and the second plurality of flutes comprises from 90 to 10 percent of the inlet face of the media element. Alternatively, the first plurality of flutes comprises from 20 to 40 percent of the inlet face of the media element, and the second plurality of flutes comprises from 60 to 80 percent of the inlet face of the media element. In other implementations the first plurality of flutes comprises from 40 to 60 percent of the inlet face of the media element, and the second plurality of flutes comprises from 60 to 40 percent of the inlet face of the media element. In yet another implementation the first plurality of flutes comprises from 60 to 90 percent of the inlet face of the media element, and the second plurality of flutes comprises from 40 to 10 percent of the inlet face of the media element.

[0127] Another embodiment of the filtration media element includes a third plurality of flutes arranged in parallel flow with the first and second plurality of flutes; wherein the first, second, and third plurality of flutes exhibit regular repeating differences in flute shape, flute size, flute height, flute width, cross-flute area, or filter media. Optionally each of the first, second, and third pluralities of flutes is arranged in a separate plurality of layers. It will be understood that in some implementations more than three pluralities of flutes arranged in parallel flow, wherein each of the plurality of flutes exhibit regular repeating differences in flute shape, flute size, flute height, flute width, cross-flute area, or filter media.

[0128] In an example construction having three types of flutes, the first, second, and third flutes can be selected such that the first plurality of flutes comprises 30 to 50 percent of the inlet face of the media element; the second plurality of flutes comprises 20 to 40 percent of the inlet face of the media element; and the third plurality of flutes comprises 20 to 40 percent of inlet face of the media element.

[0129] In another example construction having three types of flutes, the first, second, and third flutes can be selected such that the first plurality of flutes comprises 50 to 70 percent of the inlet face of the media element; the second plurality of flutes comprises 10 to 30 percent of the inlet face

of the media element; and the third plurality of flutes comprises 10 to 30 percent of inlet face of the media element.

[0130] In some implementations the plurality of layers of single facer media are arranged in a wound configuration, while in other implementations the facer media is arranged in a stacked configuration.

[0131] In some configurations the first and second plurality of layers of single facer media are arranged in an intermixed configuration with one more layers of the first plurality of single facer media alternating with one or more layers of the second plurality of single facer. In example implementations with at least three kinds of single facer media, the first and second plurality of layers of single facer media are arranged in an intermixed configuration with one more layers of the first plurality of single facer media alternating with one or more layers of the second plurality of single facer media and one or more layers of the third plurality of single facer media. Also, when three types of media are used, the first, second, and third plurality of layers of single facer media can be arranged in an intermixed configuration with one more layers of the first plurality of single facer media alternating with one or more layers of the second plurality of single facer media and one or more layers of the third plurality of single facer media. In some implementations, more than three types of filter media are used, and these different types of media can be incorporated either in an intermixed manner or a manner in an aggregated manner in which the different types of media are collected together without intermixing between types of media. Alternatively, the media can be aggregated into smaller groups and then intermixed, such as by having five layers of one media and three layers of a different media.

[0132] Now, in reference to the drawings, further aspects of the filter media, media elements, and elements will be identified.

[0133] First, regarding FIG. 1, a perspective view of an example filter element 10 is shown. The example filter element 10 includes an inlet 12, an outlet 14 on the opposite side of the element 10 from the inlet 12, and wound z-flow media 20 within the element 10. A seal is shown surrounding the inlet 12, and a support frame 40 is depicted. It will be appreciated as well that the filtration element can have flow opposite to that shown in FIG. 1, such that the inlet 12 and outlet 14 are reversed.

[0134] FIG. 2A is an enlarged schematic, cross-sectional view of a section of single facer filter media 200 suitable for use in filter media elements and filter elements as described herein. The single facer media 200 includes fluted sheet 210, along with a top facer sheet 220 and a bottom facer sheet 230. The fluted sheet 210 includes a plurality of flutes 250. A fluid stream to be filtered, such as air for an internal combustion engine, enters flutes 250 along flow path 260, and then travels along the flutes until passing through the filter media and out a different flute along fluid flow path 270. This fluid flow through fluted media elements is described in, for example, U.S. Pat. No. 7,959,702 to Rocklitz, incorporated herein by reference in its entirety.

[0135] FIG. 2B is an enlarged front view of a sheet of fluted media with a fluted sheet 280, top facer sheet 282 and facer media 284 constructed and arranged according to an embodiment of the invention is shown with dimensions of example flutes. The fluted sheet 280 includes flutes 281. The flutes 281 in the depicted embodiment have a width A

measured from a first one peak to adjacent peak. In example embodiments width A is from 0.75 to 0.125 inches, optionally from 0.5 to 0.25 inches, and optionally from 0.45 to 0.3 inches. The flutes 281 also have a height B measured from adjacent same size peaks. The flute 281 has an area between fluted sheet 281 and facing sheet 282, measured perpendicular to the flute length. The area can vary depending along the length of the flute when the height, width or shape of the flute varies along its length, such as when the flute tapers. [0136] In an example embodiment, an air filtration element for removal of particulates from an airstream comprises: a) a first plurality of flutes; and b) a second plurality of flutes arranged in a parallel flow configuration with the first plurality of flutes; the second plurality of flutes exhibiting differences in flute shape, flute size, flute height, flute width, flute length, cross-flute area, or filter media relative to the first plurality of flutes; wherein the first plurality of flutes and second plurality of flutes have a common upstream and common downstream face; and wherein when loading of the filter element with dust under substantially constant velocity, the first and second plurality of flutes perform as follows:

[0137] a) the first plurality of flutes and second plurality of flutes have substantially equal initial pressure drop from the upstream face to the downstream face;

[0138] b) the first plurality of flutes has an initial velocity greater than the initial velocity of the second plurality of flutes;

[0139] c) during dust loading, as shown in FIG. 3A:

[0140] i) the pressure drop across the first plurality of flutes and second plurality of flutes remains substantially equal relative to one another while the velocity of the first and second plurality of flutes is changing relative to one another; and

[0141] ii) the velocity across the first plurality of flutes decreases and the velocity across the second plurality of flutes increases at least until the velocity across the second plurality of flutes is greater than the velocity across the first plurality of flutes.

These properties are shown, for example, in FIG. 3A, which is a schematic representation of the change in flow of an element (this figure is representational, and not based upon actual measured test data).

[0142] In an example implementation, an air filtration media element for removal of particulates from an airstream comprises a) a first plurality of flutes; and b) a second plurality of flutes arranged in a parallel flow configuration with the first plurality of flutes; the second plurality of flutes exhibiting differences in flute shape, flute size, flute height, flute width, cross-flute area, flute length, or filter media relative to the first plurality of flutes; wherein the first plurality of flutes and second plurality of flutes have a common upstream face and a common downstream face. When loading of the filter element with dust the first and second plurality of flutes performs as follows:

[0143] a) when the first and second plurality of flutes are tested independently at the same media element velocity, the first plurality of flutes has a lower initial pressure drop $\Delta P_{1,i}$ than the initial pressure drop $\Delta P_{2,i}$ across the second plurality of flutes; and the initial slope at time a of the pressure drop/loading curve of the first plurality of flutes $\Delta(\Delta P_{1,i}/L_{1,i})_a$ is greater than the initial slope of the pressure drop/loading curve of the second plurality of flutes $\Delta(\Delta P_{2,i}/L_{2,i})_a$:

$$\Delta(\Delta P_{1,i}/L_{1,i})_a > \Delta(\Delta P_{2,i})_a$$

[0144] b) when the first and second plurality of flutes are combined and simultaneously tested with parallel flow, the first plurality of flutes at time a has an initial velocity $V_{1,a}$ greater than the initial velocity $V_{2,a}$ of the second plurality of flutes at time a:

$$V_{1,a} > V_{2,a}$$

[0145] c) When the first and second plurality of flutes are combined and simultaneously tested with parallel flow, the first plurality of flutes has at a subsequent time b an intermediate second velocity $V_{1,b}$ equal to intermediate velocity $V_{2,b}$ of the second plurality of flutes:

$$V_{1,b} = V_{2,b}$$

[0146] d) When the first and second plurality of flutes are combined and simultaneously tested with parallel flow, the first plurality of flutes has at a subsequent time c a third velocity $V_{1,c}$ less than a third velocity $V_{2,c}$ of the second plurality of flutes:

$$V_{1,c} = V_{2,c}$$

These properties are shown, for example, in FIGS. 3B and 3C, which are schematic representations of the performance of elements (these figures are representational, and not based upon actual measured test data).

[0147] In an example implementation, an air filtration element for removal of particulates from an airstream comprises: a) a first plurality of flutes; and b) a second plurality of flutes arranged in a parallel flow configuration with the first plurality of flutes; the second plurality of flutes exhibiting differences in flute shape, flute size, flute height, flute width, cross-flute area, flute length, or filter media relative to the first plurality of flutes; wherein the first plurality of flutes and second plurality of flutes have a common upstream and common downstream face. When simultaneous loading of dust under parallel flow conditions, and when loading to a point in which the media element has a pressure drop of at least 10 inches of water, the first and second plurality of flutes performs as follows:

[0148] a) the time average velocity of the first plurality of flutes \bar{V}_1 is less than the time average velocity of the entire filtration element $\bar{V}_{element}$ and the time average velocity of the second plurality of flutes \bar{V}_2 is greater than the time average velocity of the filtration element $\bar{V}_{element}$:

$$\bar{V}_1 < \bar{V}_{element}$$

$$\bar{V}_2 > \bar{V}_{element}$$

[0149] b) the change in loading of the first plurality of flutes ΔL_1 is equal to the loading of the first plurality of flutes when tested at the first plurality of flutes time average velocity $L_{1,(V1\ avg)}$ minus the loading of the first plurality of flutes when tested at the element time average velocity $L_{1,(V\ element\ avg)}$:

$$\Delta L_1 = L_{1,(V1\ avg)} - L_{1,(V\ element\ avg)}$$

$$\Delta L_1 > 0$$

[0150] c) the change in loading of the second plurality of flutes ΔL_2 is equal to the loading of the second plurality of flutes when tested at the second plurality of flutes time average velocity $L_{2,(V2\ avg)}$ minus the loading of the second plurality of flutes when tested at the element time average velocity $L_{2,(V\ element\ avg)}$:

$$\Delta L_2 = L_{2,(V2\ avg)} - L_{2,(V\ element\ avg)}$$

$$\Delta L_2 < 0$$

[0151] d) the sum of ΔL_1 and ΔL_2 is greater than 0:

$$\Delta L_1 + \Delta L_2 > 0$$

These properties are shown, for example, in FIGS. 3D and 3E which are schematic representations of the performance of elements (these figures are representational, and not based upon actual measured test data).

[0152] In an example implementation, an filtration media element for removal of particulates from an airstream comprises: a) a first plurality of flutes; and b) a second plurality of flutes arranged in a parallel flow configuration with the first plurality of flutes; the second plurality of flutes exhibiting differences in flute shape, flute size, flute height, flute width, flute length, cross-flute area, or filter media relative to the first plurality of flutes; wherein the first plurality of flutes and second plurality of flutes have a common upstream and common downstream face; and wherein the first and second plurality of flutes performs as follows:

[0153] i) the pressure drop ΔP increases as flow Q increases;

[0154] ii) before loading, when the first and second plurality of flutes are tested independently and at the same velocity, the first plurality of flutes has a lower initial pressure drop $\Delta P_{1,0}$ less than the initial pressure drop $\Delta P_{2,0}$ across the second plurality of flutes;

$$\Delta P_{1,0} < \Delta P_{2,0}$$

[0155] iii) when tested in parallel, the velocity of the first plurality of flutes before loading is greater than the average air filtration element velocity before loading, and the velocity of the second plurality of flutes before loading is less than the average air filtration element velocity before loading;

$$V_{1,0} > V_{(element\ average),0}$$

$$V_{2,0} < V_{(element\ average),0}$$

[0156] v) when tested in parallel, the difference in pressure drop $\Delta(\Delta P_1)$ is equal to the pressure drop before loading of the first plurality of flutes tested at the first plurality of flutes velocity $\Delta P_{1,0,(V1,0)}$ minus the pressure drop before loading of the first plurality of flutes when tested at the filtration element average velocity $\Delta P_{1,0,(V\ element\ avg),0}$:

$$\Delta(\Delta P_1) = \Delta P_{1,0,(V1,0)} - \Delta P_{1,0,(V\ element\ avg),0}$$

[0157] v) when tested in parallel, the difference in pressure drop $\Delta(\Delta P_2)$ of the second plurality of flutes is equal to the pressure drop before loading of the second plurality of flutes tested at the second plurality of flutes velocity $\Delta P_{2,0,(V2,0)}$ minus the pressure drop before loading of the second plurality of flutes when tested at the filtration element average velocity $\Delta P_{2,0,(V\ element\ avg),0}$:

$$\Delta(\Delta P_2) = \Delta P_{2,0,(V2,0)} - \Delta P_{2,0,(V\ element\ avg),0}$$

[0158] d) the sum of $\Delta(\Delta P_1)$ and $\Delta(\Delta P_2)$ is less than 0:

$$\Delta(\Delta P_1) + \Delta(\Delta P_2) < 0$$

These properties are shown, for example, in FIG. 3F which is a schematic representation of the performance (this figure is representational, and not based upon actual measured test data).

[0159] FIG. 4A is a top schematic view of an example filter media element 300 for use in a filter element. The filter media element 300 has two types of filter media: first media 310 and second media 320. The media is shown in a wound configuration with the two types of filter media intermixed and overlapping. The filter media 310 and 320 is shown in schematic form, without showing the actual flutes of the media. The filter media element 300 can typically be formed by winding of different types of media simultaneously around a central axis. In this example embodiment the ratio of face area of media 310 to 320 is approximately 1:1.

[0160] FIG. 4B is a top schematic view of an example filter media element 400, showing a wound configuration with three types of filter media. The filter media element 400 has three types of filter media: first media 410, a second media 420, and a third media 430. The media is shown in wound configuration with the three types of filter media intermixed and overlapping. The filter media 410, 420 and 430 is shown in schematic form, without showing the actual flutes of the media. The filter media element 430 can typically be formed by winding three different types of media simultaneously around a central axis. In this example embodiment the ratio of face area of media 410 to 420 to 430 is approximately 1:1:1.

[0161] FIG. 5 is a top schematic view of an example filter media element 500, showing a stacked configuration with two types of flutes. The filter media element 500 has two types of flutes: first flutes 510 and second flutes 520.

[0162] FIG. 6 is a top schematic view of an example filter media element 600, showing a stacked configuration with different types of filter media. The filter media element 600 has three types of flutes: first flutes 610, second flutes 620, and third flutes 630.

[0163] FIG. 7 is a top schematic view of an example filter media element 700, showing a stacked configuration with different types of flutes. The filter media element 710 has two types of flutes: first flutes 710 and second flutes 720. FIG. 8 is a top, schematic view of an example filter media element 800, showing a stacked configuration with three types of filter media. The three types of filter media are first media 810, a second media 820, and a third media 830. The media is shown in a stacked configuration with the three types of filter media being segregated by media type rather than intermixed. In this example embodiment the ratio of filter media 810 to 820 to 830 is approximately 4:3:3, based upon pack entrance area. FIG. 9 is a top schematic view of an example filter media element 900, showing a stacked configuration with two types of filter media: first media 910 and second media 920. The media is shown in stacked configuration with the two types of filter media separate rather than intermixed. In this example embodiment the ratio of filter media 910 to 920 is approximately 1:1, based upon total pack entrance area. FIG. 10 is a top schematic view of an example filter media element 1000, showing a stacked configuration with two types of filter media: first media 1010 and second media 1020. The media is shown in stacked configuration. In this example embodiment the ratio of filter media 1010 to 1020 is approximately 9:1, based upon total pack entrance area.

[0164] FIG. 11 is a top schematic view of an example filter media element, showing a stacked configuration with two types of filter media. The filter media element 1100 has two types of filter media: first media 1110 and second media 1120. The media 1110 and 1120 is stacked with five layers of filter media 1110 alternating with two layers of media 1120. FIG. 12 is a top schematic view of an example filter media element, showing a stacked configuration with two types of filter media. The filter media element 1200 has two types of filter media: first media 1210 and second media 1220. The media is shown in stacked configuration. The media 1210 and 1220 is stacked with two layers of filter media 1210 alternating with one layer of media 1220. FIG. 13 is a top schematic view of an example filter media element 1300, showing a stacked configuration with two types of filter media. The filter media element 1300 has two types of filter media: first media 1310 and second media 1320. The media 1310 and 1320 are stacked, with one layer of filter media 1310 alternating with one layer of media 1320. FIG. 14 is a top schematic view of an example filter media element 1400. The filter media element 1400 has three types of filter media: first media 1410, second media 1420, and third media 1430. The media layers 1410, 1420 and 1430 are arranged in an alternating stack. FIG. 15 is a top schematic view of an example filter media element 1500, showing a wound configuration with two types of filter media 1510 and 1520. The media is wound with the first media 1510 on the inside and the second media 1520 on the outside, the first and second medias 1510, 1520 spliced together.

[0165] FIG. 16 is a top schematic view of an example filter media element 1600, showing a wound configuration with three types of filter media 1610, 1620, and 1630. The media is wound with a first media 1610 on the inside, the second media 1620 in the middle, and the third media 1630 on the outside. The first and second medias 1610, 1620 are spliced together, as are the second and third medias 1620, 1630.

[0166] FIG. 17 is a top, partial schematic view of an example filter media element 1700, showing a stacked configuration with three types of filter media. The three types of filter media are first media 1710, second media 1720, and third media 1730. The media is shown in a stacked configuration with the three types of filter media being segregated by media type rather than intermixed. In this example embodiment the ratio of filter media 1710 to 1720 to 1730 is approximately 4:3:3, based upon total pack entrance area.

[0167] FIG. 18 is a top schematic view of an example filter media element 1800, showing a stacked configuration with two types of filter media: first media 1810 and second media 1820. The media is shown in a stacked configuration with the two types of filter media segregated. In this example embodiment the ratio of filter media 1810 to 1820 is approximately 1:1, based upon total pack entrance area.

[0168] FIG. 19 is a top schematic view of an example filter media element 1900, showing a stacked configuration with two types of filter media. The filter media element 1900 has two types of filter media: first media 1910 and second media 1920. The media is shown in stacked configuration. In this example embodiment the ratio of filter media 1910 to 1920 is approximately 9:1, based upon total pack entrance area.

[0169] FIG. 20 is a top schematic view of an example filter media element 2000, showing a stacked configuration with two types of filter media. The filter media element 2000 has

two types of filter media: first media **2010** and second media **2020**. The media element **2000** has six layers of filter media **2010** alternating with two layers of media **2020**.

[0170] FIG. 21 is a top schematic view of an example filter media element **2100**, showing a stacked configuration with two types of filter media. The filter media element **2100** has two types of filter media: first media **2110** and second media **2120**. The media element **2100** has two layers of filter media **2110** alternating with one layer of media **2120**.

[0171] FIG. 22 is a top, partial schematic view of an example filter media element **2200**, showing a stacked configuration with two types of filter media. The two types of filter media are first media **2210** and a second media **2220**. The media is shown in a stacked configuration with the two types of filter media intermixed.

[0172] FIG. 23 is a top, partial schematic view of an example filter media element **2300**, showing a stacked configuration with three types of filter media. The three types of filter media are first media **2310**, a second media **2320**, and a third media **2330**. The media is shown in a stacked configuration with the three types of filter media intermixed.

[0173] FIG. 24A is a top schematic view of an example filter media element **2400**, showing a wound configuration with two types of filter media: first media **2410**, and second media **2420**. The media is shown in a wound configuration with the two types of media distinct from one another by having filter media **2420** laid down first, and then filter media **2420** laid down second. In this example embodiment the ratio of pack entrance area **2420** to **2410** is approximately 2:1. This construction can be created by, for example, wrapping a first singleface media type for a period, cutting that web and splicing a second singleface media type to the end region of the first single face media type, continuing the wrapping process, and repeating for as many singleface media types as desired. Alternatively, winding of each singleface media type can be done separately, and the sections can be brought together and sealed as a secondary process.

[0174] FIG. 24B is a top schematic view of an example filter media element **2450**, showing a wound configuration with two types of flutes forming the filter media. The filter media element has two types of flutes: first media **2460**, and second media **2470**. The media is shown in wound configuration with the two types of flutes separated from one another. In this example embodiment the ratio of pack entrance area **2470** to **2460** is approximately 2:1.

[0175] FIG. 25A is a top schematic view of an example filter media element **2500**, showing a wound configuration with three types of filter media: first media **2510**, second media **2520**, and third media **2530**. The media is shown in a wound configuration with the media separated from one another by having filter media **2520** laid down first, and then second media **2520** laid down on top of media **2510**, and third media **2530** is laid down on top of media **2520**. In this example embodiment the ratio of pack entrance area **2510** to **2520** to **2530** is approximately 4:3:3.

[0176] FIG. 25B is a top schematic view of an example filter media element **2550**, showing a wound configuration with three types of filter media. The filter media element **2550** has first media **2560**, second media **2570** and third media **2580**. The media is shown in wound configuration with the three types of media separated from one another. In

this example embodiment the ratio of pack entrance area **2560** to **2570** to **2580** is approximately 4:3:3.

[0177] FIG. 26A is a top schematic view of an example filter media element **2600**, showing a wound configuration with two types of filter media. The filter media element **2600** has two types of filter media: first media **2610**, and second media **2620**. The media is shown in a wound configuration with the two types of media separate on one another by having filter media **2620** laid down first, and then filter media **2620** laid down on top of media **2610**. In this example embodiment the ratio of pack entrance area **2610** to **2620** is approximately 1:1.

[0178] FIG. 26B is a top schematic view of an example filter media element **2650**, showing a wound configuration with two types of filter media. The filter media element has two types of filter media: first media **2660**, and second media **2670**. The media is shown in wound configuration with the two types of media separated from one another. In this example embodiment the ratio of pack entrance area **2660** to **2670** is approximately 1:1.

[0179] Aspects may be better understood with reference to the following example, in which Element A, Element B, and Element C were compared to one another. Element A was composed entirely of Media A with flutes having a width of approximately 10.7 millimeters and height of 3.2 millimeters and a tapered cross-sectional area. Element B was composed entirely of Media B with flutes having a width of approximately 8.0 millimeters and a height of approximately 2.7 millimeters and a tapered area. The flute density per square centimeter was approximately 2.8 for Element A and 4.4 for Element B. Element C was composed of 50 percent by volume with Media A, and 50 percent by volume of Media B to form a Hybrid Media. FIG. 27 shows a loading curve for filter elements made using Media A, Media B, and the Hybrid Media. The loading curve shows the pressure drop of the filter elements as the grams of dust increases from zero to up to less than 500 grams. As shown in FIG. 27, Media B and the hybrid media started with very similar restriction levels (approximately 2.5 inches of H₂O), while Media A had a higher initial pressure drop, which is approximately 3.2 inches of H₂O. As dust begins to load the pressure drop across all elements increases, however Media A and the Hybrid Media have a slower increase in pressure drop than Media B, with the pressure drop of Media A and Media B crossing (or being the same) at about 125 grams of dust. Thus, the Hybrid Media tracked closely with Media B when dust loading was just starting, and then tracked closely with Media A as the dust loading increased to higher levels. In other words, the hybrid media had initial pressure drop similar to Media B, but loading similar to Media A.

[0180] In order to further test improved filter performance, a test bench was set up with a two-duct system having 5 to 9 cubic meters per minute of air flow, configured to measure pressure drop, as well as outlet restriction values. Relative performance of media elements formed using combinations of filter medias was investigated by constructing various filter element designs. The elements were formed with z-flow media arranged in a stacked configuration. The elements each had a 150 by 150 millimeter inlet face and a 150 by 150 millimeter outlet face and were 150 millimeters deep. Filter elements were made with two types of media: Media A and Media B. Media A and Media B had media flute constructions consistent with those shown in U.S. Pat. No. 9,623,362, entitled Filtration Media Pack, Filter Elements,

and Air Filtration Media to inventor Scott M. Brown and assigned to Donaldson Company, Inc. Media A and B were both primarily cellulosic media. Media A had a flute height of about 0.092 inch, flute width of about 0.314 inch, and flute length of about 150 millimeters (including flute plugs). Media B had a flute height of about 0.140 inch, flute width of about 0.430 inch, and flute length of about 150 millimeters (including flute plugs). A first type of “segmented” media element was assembled packs of Media A and Media B located next to one another in parallel flow. A second type of “layered” media element included alternating sheets of Media A and Media B.

[0181] FIGS. 28A to 30B show performance results, including dust loading and pressure drop, for various media constructions. FIGS. 28A, 29A and 30A show results for a segmented configuration (Media A was grouped together and all of Media B was grouped together); and FIGS. 28B, 29B, and 30B show results for a layered configuration (in which at least some of the Media A and Media layers were intermixed). Thus, the media constructions include either Media A, Media B, or various percentages by volume of Media A and Media B. Media on the far left of each graph, denoted as 0%, has no Media A and is thus entirely Media B. Media on the far right, denoted as 100%, have only Media A and thus no Media B. The Y axis contains both ISO fine dust loading measured in grams, as well as pressure drop measured in inches of water.

[0182] FIGS. 28A and 28B shows performance results, including dust loading and pressure drop, for various media constructions at a cube flow rate of 5.83 cubic meters per minute. From FIGS. 28A and 28B it will be observed that the best performance, specifically the highest dust loading, was achieved with a hybrid media: the hybrid media element containing both Media A and Media B had higher dust loading capacity than either Media A or Media B alone.

[0183] FIGS. 29A and 29B show performance results, including dust loading and pressure drop, for various media constructions at a cube flow rate of 7.37 cubic meters per minute. Again, as with FIGS. 29A and 29B, the best performance was with a hybrid media of both Media A and Media B.

[0184] FIGS. 30A and 30B show performance results, including dust loading and pressure drop, for various media constructions at a cube flow rate of 8.78 cubic meters per minute. From FIGS. 30A and 30B it will be observed that the best performance, specifically the highest dust loading, was again achieved with a hybrid media.

[0185] It should be noted that, as used in this specification and the appended claims, the singular forms “a,” “an,” and “the” include plural referents unless the content clearly dictates otherwise. Thus, for example, reference to a composition containing “a compound” includes a mixture of two or more compounds. It should also be noted that the term “or” is generally employed in its sense including “and/or” unless the content clearly dictates otherwise.

[0186] It should also be noted that, as used in this specification and the appended claims, the phrase “configured” describes a system, apparatus, or other structure that is constructed or configured to perform a particular task or adopt a particular configuration to. The phrase “configured” can be used interchangeably with other similar phrases such as arranged and configured, constructed and arranged, constructed, manufactured and arranged, and the like.

[0187] Aspects have been described with reference to various specific and preferred embodiments and techniques. However, it should be understood that many variations and modifications may be made while remaining within the spirit and scope herein.

[0188] The embodiments described herein are not intended to be exhaustive or to limit the invention to the precise forms disclosed in the following detailed description. Rather, the embodiments are chosen and described so that others skilled in the art can appreciate and understand the principles and practices.

[0189] All publications and patents mentioned herein are hereby incorporated by reference. The publications and patents disclosed herein are provided solely for their disclosure. Nothing herein is to be construed as an admission that the inventors are not entitled to antedate any publication and/or patent, including any publication and/or patent cited herein.

1-20. (canceled)

21. An air filtration media element for removal of particulates from an airstream, the air filtration media element comprising:

- a) a first plurality of flutes; and
- b) a second plurality of flutes arranged in a parallel flow configuration with the first plurality of flutes; the second plurality of flutes exhibiting differences in flute shape, flute size, flute height, flute width, cross-flute area, flute length, or filter media relative to the first plurality of flutes;

wherein the first plurality of flutes and second plurality of flutes have a common upstream face and a common downstream face;

wherein when loading of the filter element with dust the first and second plurality of flutes performs as follows:

- a) when the first and second plurality of flutes are tested independently at the same media element velocity, the first plurality of flutes has a lower initial pressure drop $\Delta P_{1,i}$ than the initial pressure drop $\Delta P_{2,i}$ across the second plurality of flutes; and the initial slope at time a of the pressure drop/loading curve of the first plurality of flutes $\Delta(\Delta P_{1,i}/L_{1,i})_a$ is greater than the initial slope of the pressure drop/loading curve of the second plurality of flutes $\Delta(\Delta P_{2,i}/L_{2,i})_a$:

$$\Delta(\Delta P_{1,i}/L_{1,i})_a > \Delta(\Delta P_{2,i}/L_{2,i})_a$$

- b) if the first and second plurality of flutes are combined and simultaneously tested with parallel flow, the first plurality of flutes at time a has an initial velocity $V_{1,a}$ greater than the initial velocity $V_{2,a}$ of the second plurality of flutes at time a:

$$V_{1,a} > V_{2,a}$$

- c) if the first and second plurality of flutes are combined and simultaneously tested with parallel flow, the first plurality of flutes has at a subsequent time b an intermediate second velocity $V_{1,b}$ equal to intermediate velocity $V_{2,b}$ of the second plurality of flutes:

$$V_{1,b} = V_{2,b}$$

- d) if the first and second plurality of flutes are combined and simultaneously tested with parallel flow, the first plurality of flutes has at a subsequent time c a third velocity $V_{1,c}$ less than a third velocity $V_{2,c}$ of the second plurality of flutes:

$$V_{1,c} < V_{2,c}$$

22. The air filtration media element of claim 21, wherein the first plurality of flutes is arranged in a first plurality of layers of the fluted media, and the second plurality of flutes is arranged in a second plurality of layers of the fluted media.

23. The air filtration media element of claim 21, wherein the first plurality of flutes comprises from 10 to 90 percent of the volume of the media element, and the second plurality of flutes comprises from 90 to 10 percent of the volume of the media element.

24. The air filtration media element of claim 21, wherein the first plurality of flutes comprises from 20 to 40 percent of the volume of the media element, and the second plurality of flutes comprises from 60 to 80 percent of the volume of the media element.

25. The air filtration media element of claim 21, wherein the first plurality of flutes comprises from 40 to 60 percent of the volume of the media element, and the second plurality of flutes comprises from 60 to 40 percent of the volume of the media element.

26. The air filtration media element of claim 21, wherein the first plurality of flutes comprises from 10 to 90 percent of the media surface area of the media element, and the second plurality of flutes comprises from 90 to 10 percent of the media surface area of the media element.

27. The air filtration media element of claim 21, wherein the first plurality of flutes comprises from 20 to 40 percent of the media surface area of the media element, and the second plurality of flutes comprises from 60 to 80 percent of the media surface area of the media element.

28. The air filtration media element of claim 21, wherein the first plurality of flutes comprises from 40 to 60 percent of media surface area of the media element, and the second plurality of flutes comprises from 60 to 40 percent of the media surface area of the media element.

29. The air filtration media element of claim 21, wherein the first plurality of flutes comprises from 10 to 90 percent of the inlet face of the media element, and the second plurality of flutes comprises from 90 to 10 percent of the inlet face of the media element.

30. The air filtration media element of claim 21, wherein the first plurality of flutes comprises from 20 to 40 percent of the inlet face of the media element, and the second plurality of flutes comprises from 60 to 80 percent of the inlet face of the media element.

31. The air filtration media element of claim 21, wherein the first plurality of flutes comprises from 40 to 60 percent of the inlet face of the media element, and the second plurality of flutes comprises from 60 to 40 percent of the inlet face of the media element.

32. The air filtration media element of claim 21, further comprising a third plurality of flutes arranged in parallel flow with the first and second plurality of flutes;

wherein the first, second, and third plurality of flutes exhibit differences in flute shape, flute size, flute height, flute width, flute length cross-flute area, or filter media.

33. The air filtration media element claim 21, wherein each of the first, second, and third pluralities of flutes is arranged in a separate plurality of layers.

34. The air filtration media element of claim 21, wherein the plurality of layers media are arranged in a wound or stacked configuration.

35. The air filtration media element of claim 21, wherein the differences in flute shape, flute size, flute height, flute width, cross-flute area or filter media are regular and repeating.

36. An air filtration element for removal of particulates from an airstream, the air filtration element comprising:

- a first plurality of flutes; and
- a second plurality of flutes arranged in a parallel flow configuration with the first plurality of flutes; the second plurality of flutes exhibiting differences in flute shape, flute size, flute height, flute width, cross-flute area, flute length, or filter media relative to the first plurality of flutes;

wherein the first plurality of flutes and second plurality of flutes have a common upstream and common downstream face;

wherein when simultaneous loading of dust under parallel flow conditions, and when loading to a point in which the media element has a pressure drop of at least 10 inches of water, the first and second plurality of flutes performs as follows:

- the time average velocity of the first plurality of flutes \bar{V}_1 is less than the time average velocity of the entire filtration element $\bar{V}_{element}$, and the time average velocity of the second plurality of flutes \bar{V}_2 is greater than the time average velocity of the filtration element $\bar{V}_{element}$:

$$\bar{V}_1 < \bar{V}_{element}$$

$$\bar{V}_2 > \bar{V}_{element}$$

- the change in loading of the first plurality of flutes ΔL_1 is equal to the loading of the first plurality of flutes when tested at the first plurality of flutes time average velocity $L_{1,(V1\ avg)}$ minus the loading of the first plurality of flutes when tested at the element time average velocity $L_{1,(V\ element\ avg)}$:

$$\Delta L_1 = L_{1,(V1\ avg)} - L_{1,(V\ element\ avg)}$$

$$\Delta L_1 > 0$$

- the change in loading of the second plurality of flutes ΔL_2 is equal to the loading of the second plurality of flutes when tested at the second plurality of flutes time average velocity $L_{2,(V2\ avg)}$ minus the loading of the second plurality of flutes when tested at the element time average velocity $L_{2,(V\ element\ avg)}$:

$$\Delta L_2 = L_{2,(V2\ avg)} - L_{2,(V\ element\ avg)}$$

$$\Delta L_2 > 0$$

- the sum of ΔL_1 and ΔL_2 is greater than 0:

$$\Delta L_1 + \Delta L_2 > 0$$

37. The air filtration media element of claim 36, wherein the first plurality of flutes is arranged in a first plurality of layers of the fluted media, and the second plurality of flutes is arranged in a second plurality of layers of the fluted media.

38. The air filtration media element of claim 36, wherein the first plurality of flutes comprises from 10 to 90 percent of the volume of the media element, and the second plurality of flutes comprises from 90 to 10 percent of the volume of the media element.

39. The air filtration media element of claim 36, wherein the first plurality of flutes comprises from 20 to 40 percent

of the volume of the media element, and the second plurality of flutes comprises from 60 to 80 percent of the volume of the media element.

40. The air filtration media element of claim **36**, wherein the first plurality of flutes comprises from 40 to 60 percent of the volume of the media element, and the second plurality of flutes comprises from 60 to 40 percent of the volume of the media element.

* * * * *