



US 20150165602A1

(19) **United States**

(12) **Patent Application Publication**

Seith et al.

(10) **Pub. No.: US 2015/0165602 A1**

(43) **Pub. Date: Jun. 18, 2015**

(54) **IMPACT TOOLS WITH PRESSURE VERIFICATION AND/OR ADJUSTMENT**

(52) **U.S. Cl.**
CPC . *B25B 21/02* (2013.01); *B25F 3/00* (2013.01); *B60C 25/0548* (2013.04)

(71) Applicant: **Ingersoll-Rand Company**, Davidson, NC (US)

(72) Inventors: **Warren A. Seith**, Bethlehem, PA (US); **Aaron M. Crescenti**, Glen Gardner, NJ (US)

(57) **ABSTRACT**

(21) Appl. No.: **14/104,039**

(22) Filed: **Dec. 12, 2013**

Illustrative embodiments of impact tools having pressure verification and/or adjustment systems are disclosed. According to at least one illustrative embodiment, an impact tool may comprise a housing, an impact mechanism supported in the housing, a motor supported in the housing, and a pressure probe coupled to the housing. The impact mechanism may be configured to drive rotation of an output shaft about a first axis, the motor may be configured to drive the impact mechanism when energized, and the pressure probe may be configured to couple to a valve of a motor vehicle tire to measure an air pressure of the motor vehicle tire.

Publication Classification

(51) **Int. Cl.**
B25B 21/02 (2006.01)
B60C 25/05 (2006.01)
B25F 3/00 (2006.01)

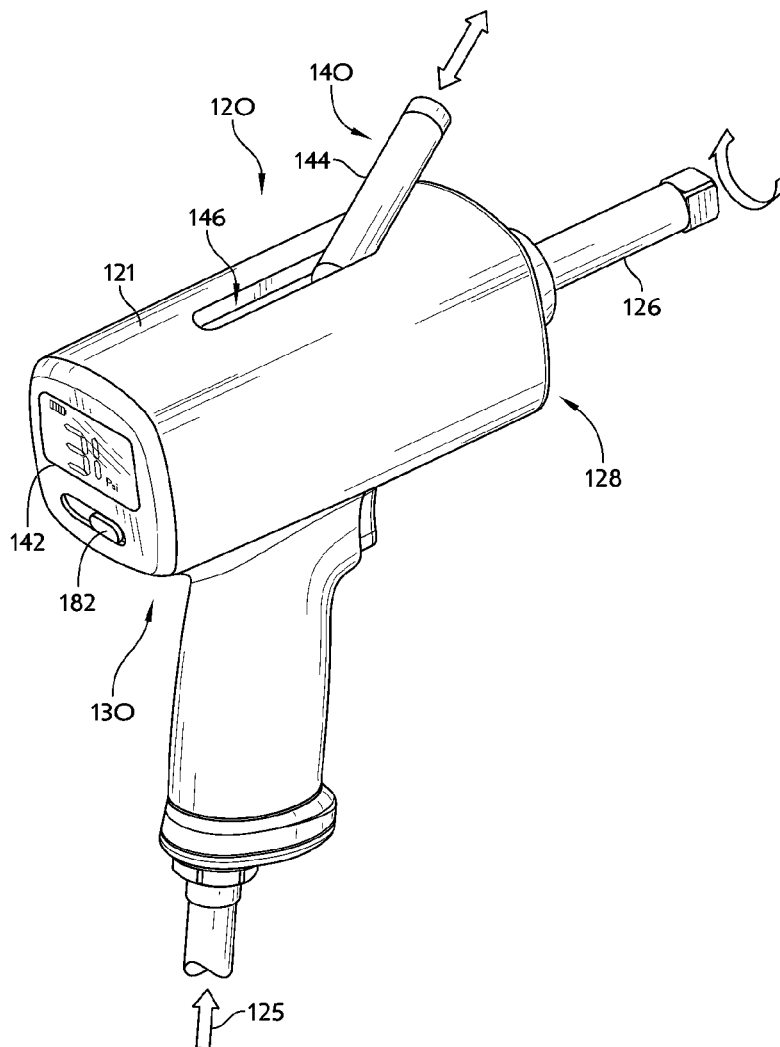

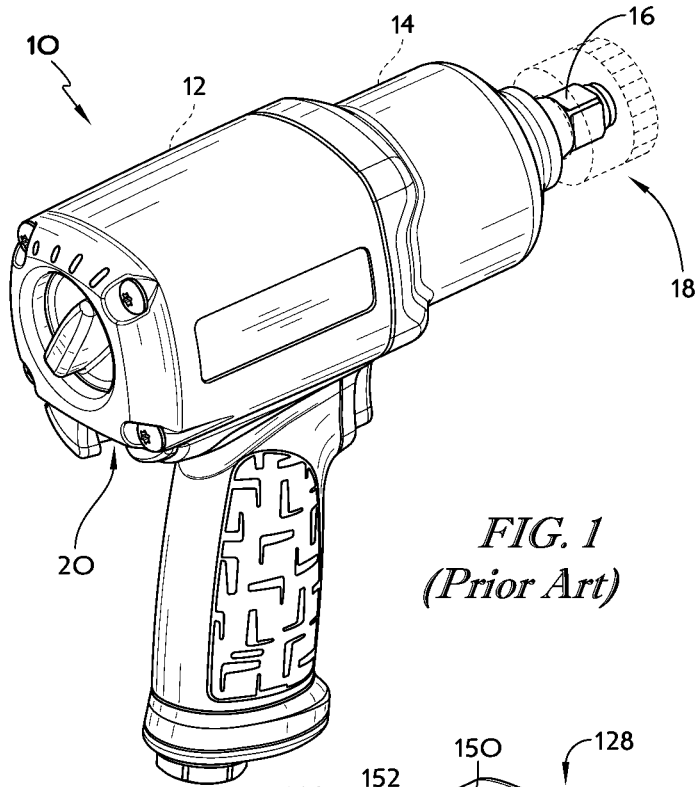

FIG. 1
(Prior Art)

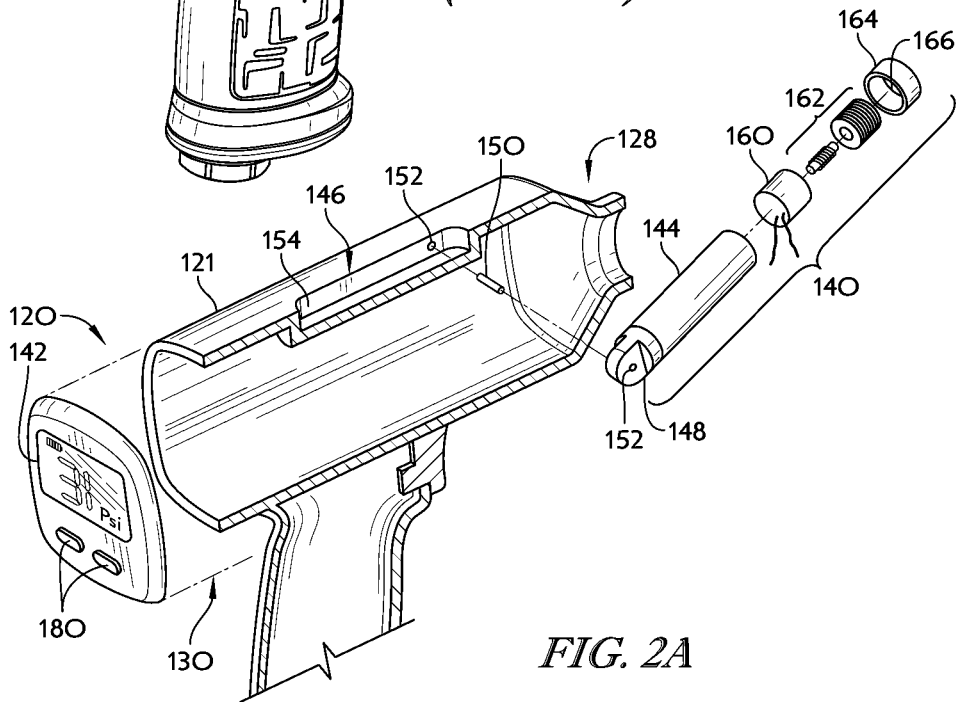

FIG. 2A

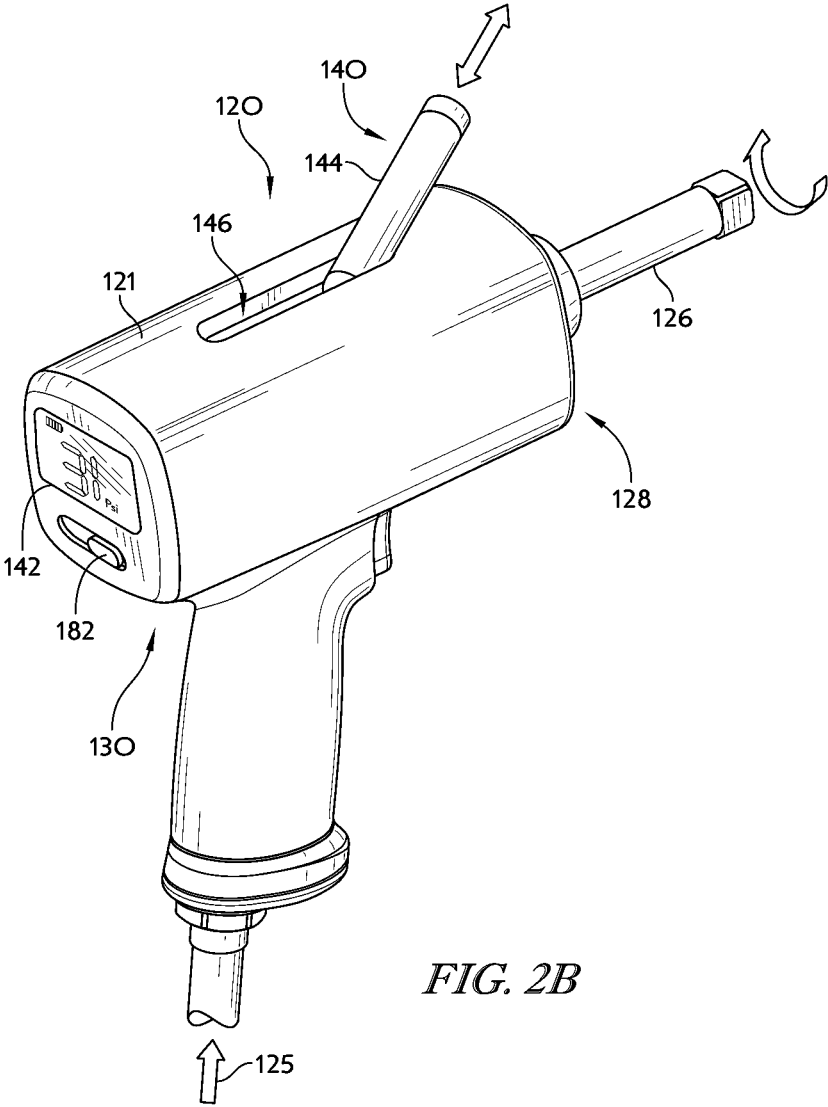

FIG. 2B

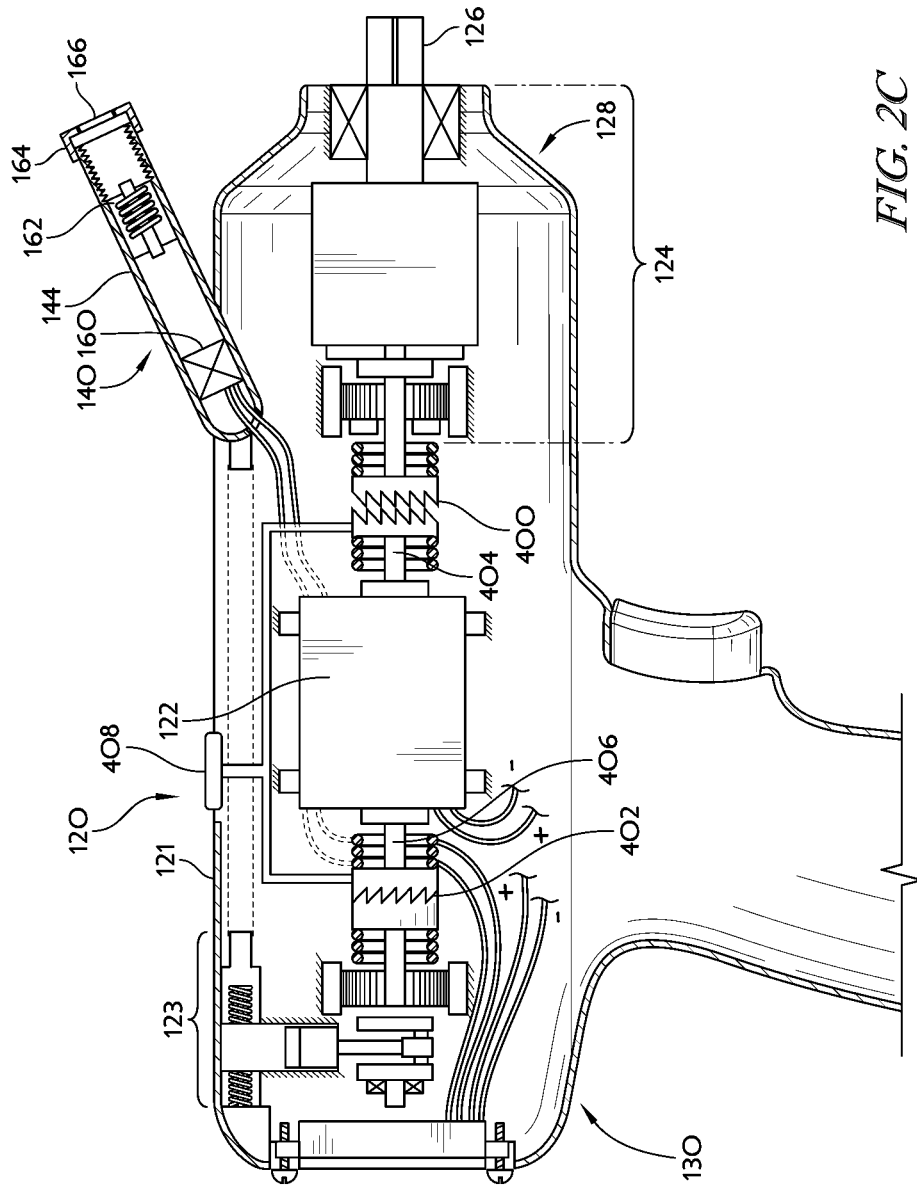

FIG. 2C

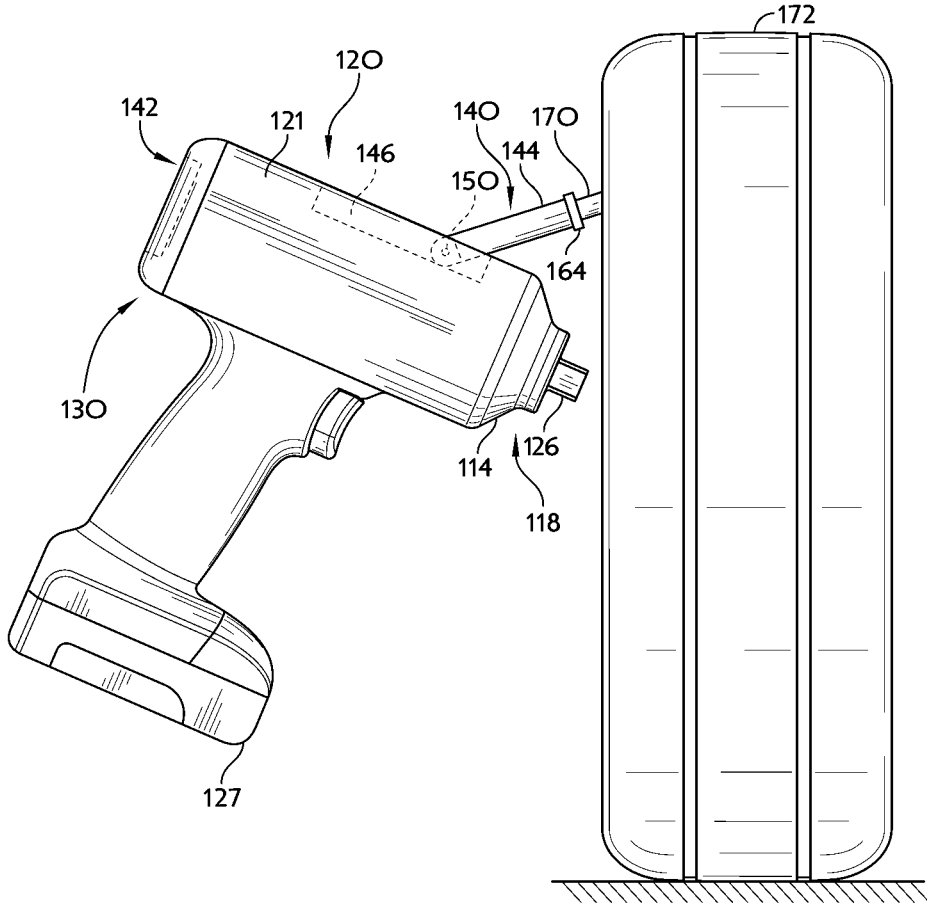

FIG. 2D

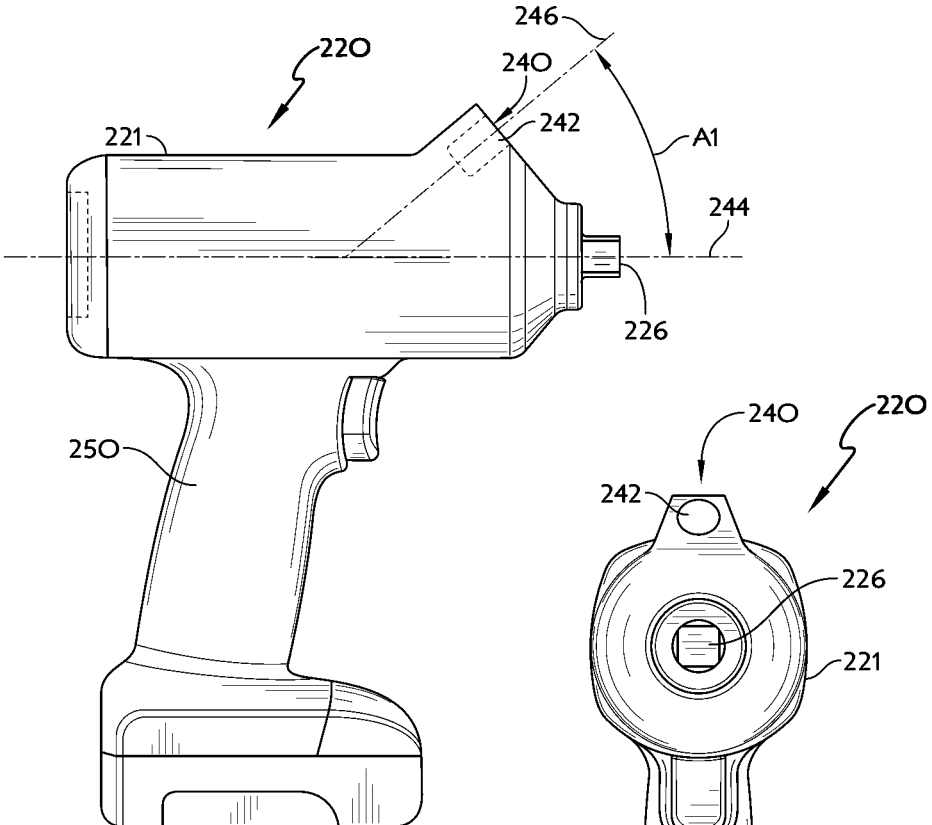

FIG. 3A

FIG. 3B

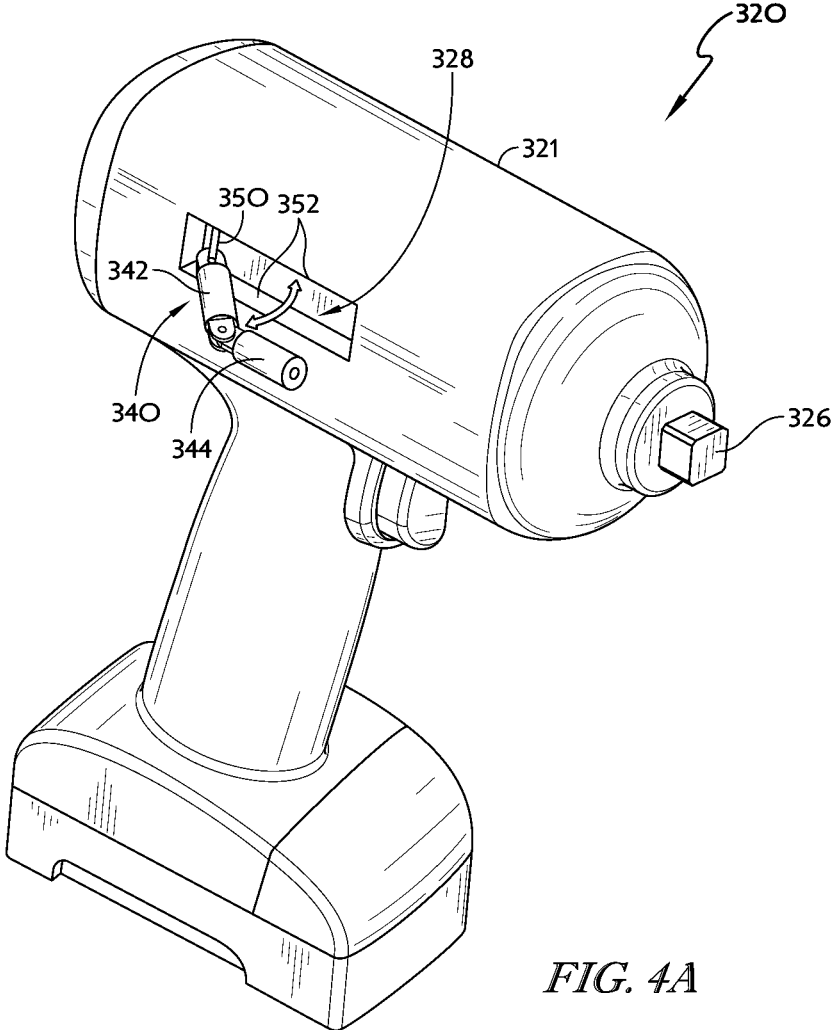

FIG. 4A

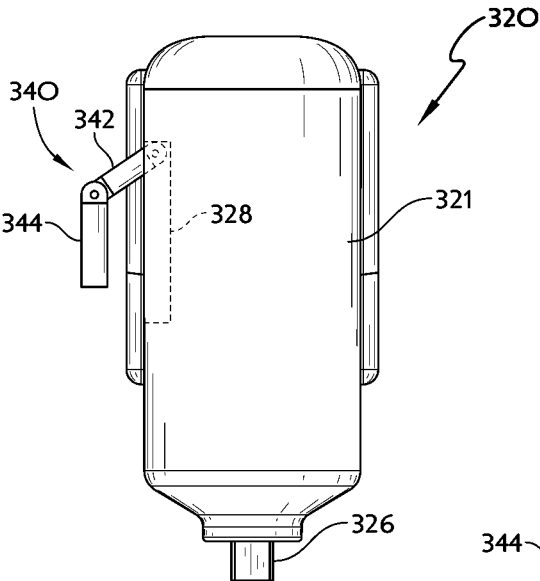

FIG. 4B

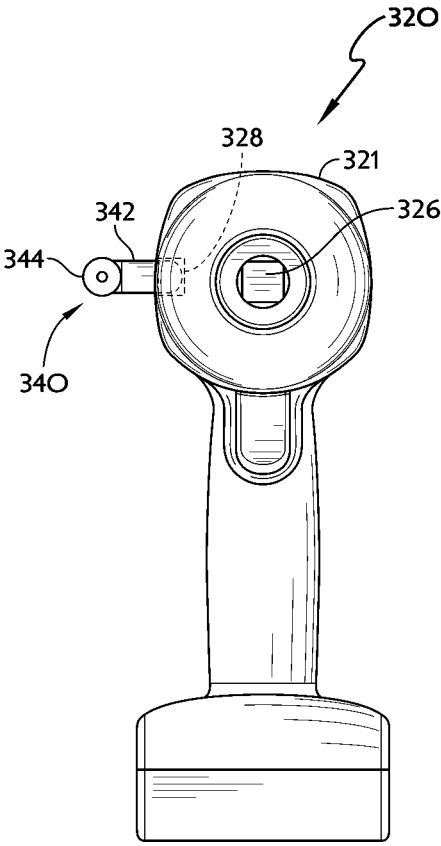

FIG. 4C

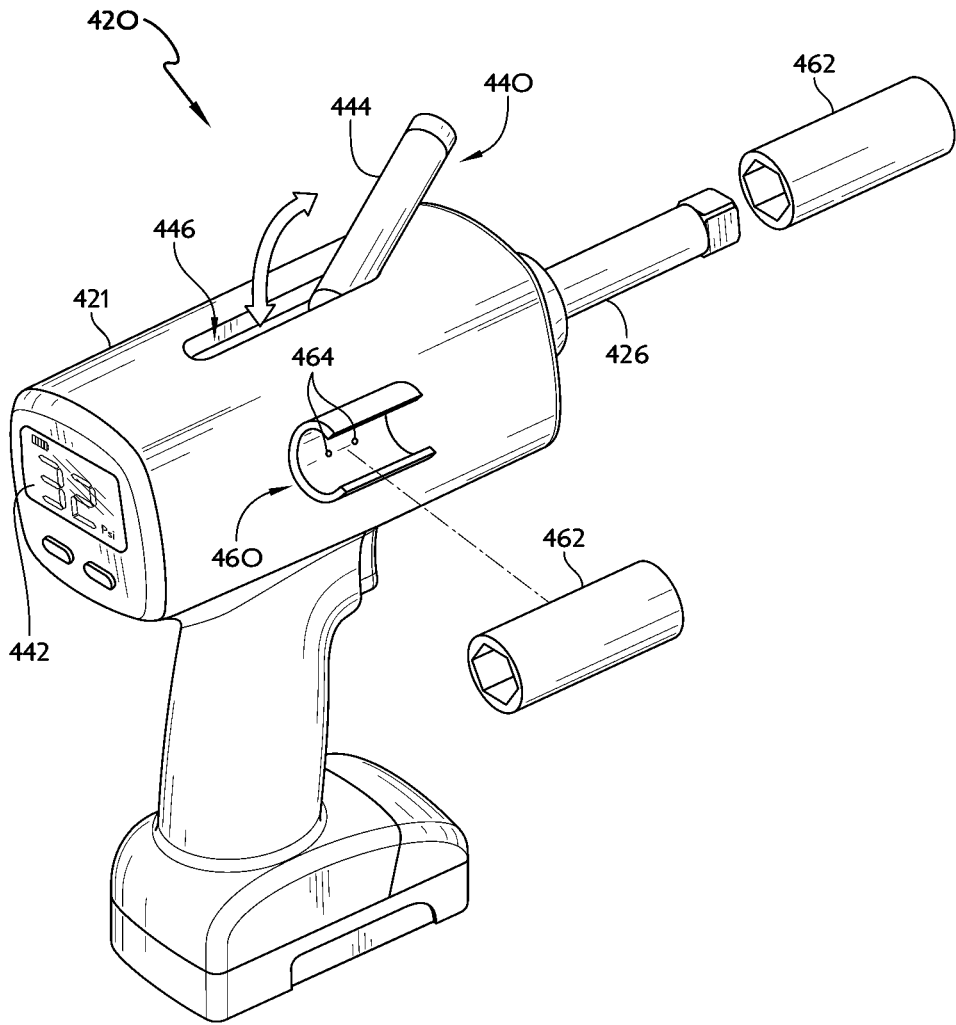

FIG. 5

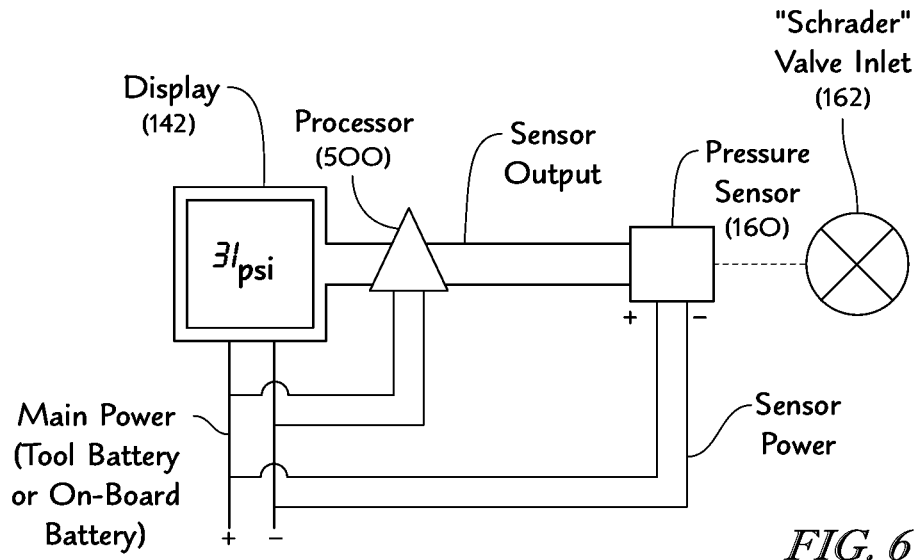

FIG. 6

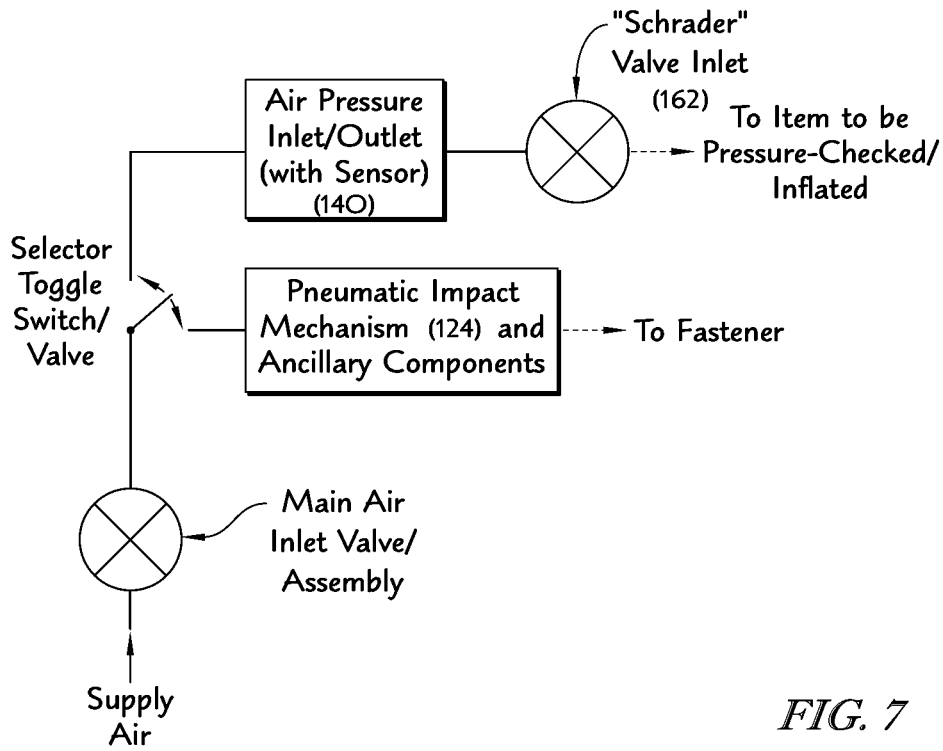

FIG. 7

IMPACT TOOLS WITH PRESSURE VERIFICATION AND/OR ADJUSTMENT

TECHNICAL FIELD

[0001] The present disclosure relates generally to impact tools. More particularly, the present disclosure relates to impact tools having pressure verification and/or adjustment systems.

BACKGROUND

[0002] An impact wrench or impact tool may be used to install and remove threaded fasteners. Impact tools generally include a motor coupled to an impact mechanism that converts the torque of the motor into a series of powerful rotary blows directed from a hammer to an output shaft called an anvil. While impact tools have many uses, impact tools are often used when installing and removing lug nuts that secure an automotive wheel or tire assembly to a vehicle. Impact tools are preferred in such situations because they offer reactionless operation (i.e., the user does not have to fight a reaction torque as the impact tool tightens or removes a fastener), they provide the ability to loosen stubborn fasteners, and they operate quickly and efficiently.

SUMMARY

[0003] According to one aspect, an impact tool may comprise a housing, an impact mechanism supported in the housing, a motor supported in the housing, and a pressure probe coupled to the housing. The impact mechanism may be configured to drive rotation of an output shaft about a first axis, the motor may be configured to drive the impact mechanism when energized, and the pressure probe may be configured to couple to a valve of a motor vehicle tire to measure an air pressure of the motor vehicle tire.

[0004] In some embodiments, the impact tool may further comprise a display supported by the housing. The display may be configured to provide an indication of the air pressure of the motor vehicle tire measured by the pressure probe.

[0005] In some embodiments, the housing may include a cavity formed therein, where the cavity is configured to receive the pressure probe when not in use. The pressure probe may be rotatably mounted within the cavity such that the pressure probe is configured to be rotated out of the cavity for use. The pressure probe may include a first arm rotatably mounted within the cavity and second arm rotatably mounted to the first arm.

[0006] In some embodiments, the pressure probe may be integrally formed as part of the housing. The pressure probe may extend along a second axis that is non-parallel to the first axis.

[0007] In some embodiments, the pressure probe may be further configured to adjust the air pressure of the motor vehicle tire. The impact tool may further comprise an air compressor supported in the housing and configured to be driven by the motor, and the pressure probe may be in fluid communication with the air compressor. The impact tool may be configured to be connected to an external source of pressurized air, and the pressure probe may be in selective fluid communication with the source of pressurized air.

[0008] In some embodiments, the impact tool may further comprise an implement holder coupled to the housing of the

impact tool. The implement holder may be configured to hold an implement that may be removably coupled to the output shaft.

[0009] In some embodiments, the impact mechanism may comprise an anvil coupled to the output shaft and configured to rotate about the first axis. The impact mechanism may further comprise a hammer configured to rotate about the first axis to periodically deliver an impact blow to the anvil to cause rotation thereof.

[0010] According to another aspect, an impact tool may comprise a housing, a motor supported in the housing, an output shaft supported by the housing, where the output shaft is configured to rotate about a first axis, an impact mechanism supported in the housing, where the impact mechanism comprises an anvil coupled to the output shaft and a hammer configured to rotate when driven by the motor to periodically deliver an impact blow to the anvil to cause rotation of the anvil and the output shaft, a pressure probe coupled to the housing, where the pressure probe is configured to couple to a valve of a motor vehicle tire to measure an air pressure of the motor vehicle tire, and a display supported by the housing, where the display is configured to provide an indication of the air pressure of the motor vehicle tire measured by the pressure probe.

BRIEF DESCRIPTION

[0011] The concepts described in the present disclosure are illustrated by way of example and not by way of limitation in the accompanying figures. For simplicity and clarity of illustration, elements illustrated in the figures are not necessarily drawn to scale. For example, the dimensions of some elements may be exaggerated relative to other elements for clarity. Further, where considered appropriate, the same or similar reference labels have been repeated among the figures to indicate corresponding or analogous elements.

[0012] FIG. 1 is a top, rear perspective view of an impact tool;

[0013] FIG. 2A is a top, rear perspective, partial cross-sectional, and partial exploded view of an impact tool, similar to the impact tool of FIG. 1, with internal components removed therefrom and incorporating a first illustrative embodiment of a pressure verification and/or adjustment system;

[0014] FIG. 2B is a top, rear perspective view of the impact tool of FIG. 2A;

[0015] FIG. 2C is partial cross-sectional view of another impact tool, incorporating a second illustrative embodiment of a pressure verification and/or adjustment system;

[0016] FIG. 2D is a side elevation view of the impact tool of FIG. 2C, with a pressure probe of the second illustrative embodiment of the pressure verification and/or adjustment system attached to a pressure valve of a tire to determine and/or adjust a pressure thereof;

[0017] FIG. 3A is a side elevation view of another impact tool, incorporating a third illustrative embodiment of a pressure verification and/or adjustment system;

[0018] FIG. 3B is a front elevation view of the impact tool of FIG. 3A;

[0019] FIG. 4A is a top, front perspective view another impact tool, incorporating a fourth illustrative embodiment of a pressure verification and/or adjustment system;

[0020] FIG. 4B is a top elevation view of the impact tool of FIG. 4A;

[0021] FIG. 4C is a front elevation view of the impact tool of FIG. 4A;

[0022] FIG. 5 is a top, rear perspective view of another impact tool, incorporating a fifth illustrative embodiment of a pressure verification and/or adjustment system;

[0023] FIG. 6 is a basic system schematic for any of the pressure verification and/or adjustment systems disclosed herein; and

[0024] FIG. 7 is a system diagram for an exemplary pneumatic impact tool with pressure verification and/or adjustment capabilities.

DETAILED DESCRIPTION

[0025] While the concepts of the present disclosure are susceptible to various modifications and alternative forms, specific exemplary embodiments thereof have been shown by way of example in the figures and will herein be described in detail. It should be understood, however, that there is no intent to limit the concepts of the present disclosure to the particular forms disclosed, but on the contrary, the intention is to cover all modifications, equivalents, and alternatives falling within the spirit and scope of the present disclosure.

[0026] A prior art impact tool 10 is depicted in FIG. 1. The impact tool 10 generally includes a motor 12, an impact mechanism 14 driven by the motor 12, and an output shaft 16 driven for rotation by the impact mechanism 14. The motor 12 may illustratively be embodied as an electric motor or a pneumatic motor. The impact tool 10 has a forward output end 18 and a rear end 20. In some illustrative embodiments, the impact mechanism 14 of the impact tool 10 may be of the type commonly known as a “ball-and-cam” impact mechanism. U.S. Pat. No. 2,160,150 to Jimerson et al. (the entire disclosure of which is hereby incorporated by reference) describes at least one embodiment of such a ball-and-cam impact mechanism. In other illustrative embodiments, the impact mechanism 14 of the impact tool may be embodied as a “swinging-weight” type impact mechanism, such as those disclosed in U.S. Pat. No. 3,661,217 to Maurer (the entire disclosure of which is hereby incorporated by reference), by way of example. In still other illustrative embodiments, the impact tool 10 may include any other suitable impact mechanism 14. Further, it will be understood by one skilled in the art that the principles of the present disclosure may be implemented within any impact tool.

[0027] Referring now to FIGS. 2A-D, exemplary impacts tools 120 incorporating illustrative embodiments of a pressure verification and/or adjustment system are depicted. The impact tools 120 each generally include a housing 121 supporting a motor 122, an impact mechanism 124 driven by the motor 122, and an output shaft 126 that extends from a forward output end 128 (opposite a rear end 130) of the housing 121 and is driven for rotation by the impact mechanism 124. In the illustrative embodiment of FIGS. 2A and 2B, the impact tool 120 includes a pneumatic motor 122 (not shown) that may be connected to an external source of pressurized air 125, as indicated in FIG. 2B. As described further below (with reference to FIG. 7), in some embodiments where the impact tool 120 is connected to an external source of pressurized air 125, the pressurized air 125 may be also be optionally supplied to the pressure verification and/or adjustment system (e.g., via an valve that diverts some or all of pressurized air 125 from the pneumatic motor 122 to the pressure verification and/or adjustment system of the impact tool 120).

[0028] In the illustrative embodiment of FIGS. 2C and 2D, the impact tool 120 instead includes an electric motor 122 (rather than a pneumatic motor). The electric motor 122 may be connected to a rechargeable battery 127 removably coupled to the impact tool 120 (as shown in FIG. 2D) or to an external source of electrical power. As shown in FIG. 2C and further described below, in some embodiments where the impact tool 120 includes an electric motor 122 and is not connected to an external source of pressurized air 125, the impact tool 120 may optionally include an air compressor assembly 123 that provides an onboard source of pressurized air for the pressure verification and/or adjustment system.

[0029] The pressure verification and/or adjustment system of FIGS. 2A-D includes a pressure probe 140 and a display 142 (illustratively shown as a digital display 142). In the illustrative embodiments of FIGS. 2A-D, the pressure probe 140 includes a body 144 that is connected to the housing 121 of the impact tool 120. In these illustrative embodiments, the housing 121 of the impact tool 120 includes a cavity 146 in which the pressure probe 140 may be stored while not in use. More particularly, one end 148 of the body 144 of the pressure probe 40 may be attached to the impact tool 120 by inserting a pin 150 through holes 152 formed in the end 148 of the body 144 and in opposing walls 154 (one shown) bounding the cavity 146. In this manner, the pressure probe 140 may be rotated into the cavity 146 for storage or out of the cavity 146 for use. In the illustrative embodiments shown in FIGS. 2A-D, the pressure probe 140 may be stored within the cavity 146 such that no portion of the pressure probe 140 extends beyond an outer surface of the housing 121 of the impact tool 120. In alternative illustrative embodiments, the pressure probe 140 may partially protrude out of the cavity 146 during storage. In some embodiments, the pin 150 may extend into elongate slots within the walls 154 such that the pin 150 may slide along the slots and, thus, along the cavity 146. In still other embodiments, the pressure probe 40 may be removably stored within the cavity 146 such that the pressure probe 140 may be entirely removed from the cavity 146 and moved in any dimension relative to the housing 121 of the impact tool 120.

[0030] As seen in FIGS. 2A and 2C, the pressure probe 140 may further include a pressure sensor 160 and a valve 162 (e.g., a “Schrader” valve) held within the body 144 by an end cap 164 having an inlet 166. The pressure probe 140 may function similarly to known pressure sensing devices to measure the internal pressure of, for example, a tire 172. When the pressure probe 140 is rotated to a use position, the inlet 166 may receive a valve stem 170 of a tire 172 (e.g., the tire of a motor vehicle), as shown in FIG. 2D. The pressure sensor 160 is electrically connected to a processor incorporated within the display 142 (or, alternatively, within another part of the impact tool 120), which is configured to receive the electrical signals from the pressure sensor 160 and to present the sensed pressure of the tire 172 on the display 142. In some embodiments, the display 142 may present any additional information, such as previous sensed pressures, battery life, supplied air pressure, and/or any other relevant information. The display 142 may also include other input and output features, including, but not limited to, various buttons 180 (see, e.g., FIG. 2A), switches 182 (see, e.g., FIG. 2B), and/or lights. In some illustrative embodiments, one or more buttons 180 may be utilized to illuminate the display 142, turn the display 142 on and/or off, reset the pressure on the display 142, or perform any other desired function(s). Additionally or alternatively, a

selector switch **182** may be provided on the display **142** (or on the housing **121**) to activate the pressure sensor **160** of the pressure probe **140**, control the supply of pressurized air to the pressure probe **140**, or perform any other desired function (s).

[0031] An impact tool **220** incorporating another illustrative embodiment of a pressure verification and/or adjustment system is depicted in FIGS. 3A and 3B. The internal components of the impact tool **220** may be similar to any of the other impact tools described herein. The impact tool **220** includes a housing **221** that integrally incorporates a pressure probe **240**. In this illustrative embodiment, the pressure probe **240** is fixedly formed as part of the housing **221**. In particular, the components of the pressure probe **240** may be positioned within the housing and an inlet **242** for the pressure probe **240** may be molded or otherwise fixedly formed as part of the housing **221**, thereby providing rigidity to the pressure probe **240** and the inlet **242**. It is contemplated that the pressure probe **240** may be formed in any portion of the housing **221** of the impact tool **220**. In illustrative embodiments, an insertion axis **246** of the pressure probe **240** may be positioned at an angle A1 with respect to an output axis **244** of the impact tool **220** to allow a user to grasp a handle **250** of the impact tool **220**, tilt the impact tool **220**, and insert a valve stem (e.g., of a tire) into the inlet **242** along the insertion axis **246**. The angle A1 prevents interference between the pressure probe **240** and an output shaft **226** of the impact tool **220** during operation of one or the other. While not specifically depicted in FIGS. 3A and 3B, the pressure verification and/or adjustment system of the impact tool **220** may also include a display, as disclosed with respect to the illustrative embodiment of FIGS. 2A-2D. Likewise, the pressure probe **240** may include similar internal components to the pressure probe **140** of the illustrative embodiments of FIGS. 2A-2D.

[0032] An impact tool **320** incorporating another illustrative embodiment of a pressure verification and/or adjustment system is depicted in FIGS. 4A-C. The internal components of the impact tool **320** may be similar to any of the other impact tools described herein. The impact tool **320** includes a housing **321** supporting a motor, an impact mechanism driven by the motor, and an output shaft **326** that extends from the housing **321** and is driven for rotation by the impact mechanism. The impact tool **320** also includes a pressure probe **340** and a display (not shown), which are generally similar to those described in detail above with reference to FIGS. 2A-2D. The pressure probe **340** of the impact tool **320**, however, includes two or more arms **342**, **344** that may be attached by pins, or any other fasteners, that allow the arms **342**, **344** to articulate with respect to one another. A cavity **328** may be formed within a portion of the housing **321** for storage of the pressure probe **340** when not in use. In the illustrative embodiment shown in FIGS. 4A-C, the pressure probe **340** is coupled to the housing **321** by inserting a pin **350** through holes (not shown) formed in the arm **342** and in opposing walls **352** bounding the cavity **328**. In this manner, the arm **342** of the pressure probe **340** may be rotated into the cavity **328** for storage of the pressure probe **340** or out of the cavity **328** for use. Furthermore, the arm **344** may be rotated about the arm **342** to bend the pressure probe **340** into a desired orientation. In this manner, the pressure probe **340** provides additional flexibility in maneuvering, for example, into small or oddly shaped spaces.

[0033] Yet another illustrative embodiment of an impact tool **420** having a pressure verification and/or adjustment

system is depicted in FIG. 5. The internal components of the impact tool **420** may be similar to any of the other impact tools described herein. The impact tool **420** includes a housing **421** supporting a motor, an impact mechanism driven by the motor, and an output shaft **426** that extends from the housing **421** and is driven for rotation by the impact mechanism. While the impact tool **420** is shown in FIG. 5 as an electrically powered tool (e.g., having an electric motor and optionally including an air compressor assembly), the impact tool **420** may alternatively be a pneumatically powered tool connected to an external source of pressurized air. The pressure verification and/or adjustment system of the impact tool **420** includes a pressure probe **440** and a pressure display **442**, which are similar in structure and operation to the pressure probe **140** and the display **142** described above with reference to FIGS. 2A-D (but, alternatively, might be similar to any of the other pressure verification and/or adjustment systems described herein). In particular, the pressure probe **440** includes a body **444** that may rotate in and out of a cavity **446** formed in the housing **421** of the impact tool **420**. As shown in FIG. 5, the impact tool **420** also includes an implement holder **460**, for example, in the form of a socket clip, coupled to the housing **421**. The implement holder **460** may be integral with or otherwise attached (e.g., by screws or other fasteners **464**) to the housing **421** of the impact tool **420**. The illustrative implement holder **460** is configured to hold, for example, a double-sided socket **462**. It is contemplated that any number of implement holders **460** may be coupled to the housing **421** to hold any number of sockets **462** and/or any other implements for attachment to the output shaft **426**. The implement holder(s) **460** provide easy access to implements during use of the impact tool **420**.

[0034] Any of the pressure verification and/or adjustment systems of the impact tools **120**, **220**, **320**, **420** described herein may be coupled to a tire valve stem **170** to measure a pressure of a tire **172** (as illustratively shown in FIG. 2D). A basic system diagram showing the electrical components of the presently disclosed pressure verification and/or adjustment systems that allow for such measurement of the pressure of the tire **172** is depicted in FIG. 6 (and will be illustratively described with reference to the pressure verification and/or adjustment system of FIGS. 2A-2D). The valve **162** (e.g., a Schrader valve) of the pressure probe **140** is fluidly coupled to the pressure sensor **160**. The pressure sensor **160** is electrically coupled to a processor **500** that receives electrical signals regarding sensed pressure(s) from the pressure sensor **160**. The processor **500** is electrically coupled to the display **142** to generate an indication of the sensed pressure(s) on the display **142**. As mentioned above, in some embodiments, the processor **500** may be incorporated into the display **142**. Each of the pressure sensor **160**, the processor **500**, and the display **142** is electrically coupled to an electrical power source of the impact tool **120**. For instance, where the motor **112** of the impact tool **120** is electrically powered (such as FIGS. 2C and 2D), the pressure sensor **160**, the processor **500**, and the display **142** may draw electrical power from a rechargeable battery **127** coupled to the impact tool **120**. In embodiments where the motor **112** of the impact tool **120** is pneumatically powered (such as FIGS. 2A and 2B), a small battery may be incorporated directly into the pressure verification and/or adjustment system to provide power to the pressure sensor **160**, the processor **500**, and the digital display **142**.

[0035] In some illustrative embodiments, any of the pressure verification and/or adjustment systems of the impact

tools **120**, **220**, **320**, **420** described herein may further be configured to adjust the pressure of the tire **172** via the tire valve stem **170** to which the pressure probe **140**, **240**, **340**, **440** is coupled. For example, in some illustrative embodiments, the pressure probe **140** may be operable to selectively bleed air from the tire **172** to decrease the pressure of the tire **172**. In some embodiments, a button **180** or switch **182** of the display **142** (or another user input mechanism located in any suitable position on the housing **121** of the impact tool **120**) may be operated by a user to selectively allow air to pass through the pressure probe **140** and be vented to the atmosphere.

[0036] In some illustrative embodiments, any of the pressure verification and/or adjustment systems of the impact tools **120**, **220**, **320**, **420** described herein may further be configured to increase the pressure of the tire **172** by supplying additional pressurized air to the tire valve stem **170** via the pressure probe **140**, **240**, **340**, **440**. One illustrative system diagram for an exemplary pneumatic impact tool (such as the impact tool **120** of FIGS. 2A and 2B) with such a pressure verification and adjustment system is depicted in FIG. 7. As described above, the impact tool **120** is provided with pressurized air **125** (from an external source) through an inlet valve. A selector switch or valve incorporated in the impact tool **120** may be used to selectively direct air to the pneumatic motor **122** (to operate the impact mechanism **124** and cause rotation of the output shaft **126** to tighten or loosen a fastener) and/or to the pressure probe **140** (to supply pressured air to the tire valve stem **170** coupled to the valve **162** of the pressure probe **140**). In some embodiments, a button **180** or switch **182** of the display **142** (or another user input mechanism located in any suitable position on the housing **121** of the impact tool **120**) may be operated by a user to toggle the selector switch or valve. In this manner, at least a portion of the pressurized air **125** may be diverted from the pneumatic motor **122** for use in increasing the air pressure of the tire **172**.

[0037] In embodiments in which the impact tool is not connected to an external source of pressurized air (for example, the electrically powered impact tool **120** of FIGS. 2C and 2D or the electrically powered impact tools **220**, **320**, **420** of FIGS. 3A-5), the impact tool may include an on-board air compressor **123**, one illustrative embodiment of which is shown in partial cross-section in FIG. 2C. The air compressor **123** may be fluidly coupled to the pressure probe **140** of the impact tool **120** to supply pressurized air to the pressure probe **140** when the air compressor **123** is operated. As shown in FIG. 2C, a selector switch **408** may be used to alternately engage and disengage forward and aft shut-off clutches **400**, **402** connected to the electric motor **122** by forward and aft output shaft connections **404**, **406**. When rotation of the output shaft **126** of the impact tool **120** is desired, the forward shut-off clutch **400** is engaged and the electric motor **122** is used to drive the impact mechanism **124** to cause rotation of the output shaft **126** (while the aft shut-off clutch **402** remains disengaged). When operation of the air compressor **123** is desired, the selector switch **408** may be slid toward the rear end **130** of the impact tool **120** to engage the aft shut-off clutch **402** and to simultaneously disengage the forward shut-off clutch **400** (as shown in FIG. 2C). In this position, operation of the electric motor **122** will drive the air compressor **123** (rather than the impact mechanism **120**), allowing the air compressor **123** to provide pressurized air to the pressure probe **140**. The impact tool **120** may be returned to the other mode of operation by sliding the selector switch **408** toward the front end **128** of the impact tool **120**.

[0038] If the pressure probe **140**, **240**, **340**, **440** of any of the illustrative embodiments described herein is used to adjust pressure, the processor **500** may be used to achieve a desired pressure setting. In some illustrative embodiment, a user may be able to enter a desired pressure value, connect the pressure probe **140**, **240**, **340**, **440** to a valve, and the processor **500** may control the pressure probe **140**, **240**, **340**, **440** to supply and/or bleed pressurized air to/from the valve until the desired pressure is achieved. For example, the processor **500** might utilize an algorithm mimicking the technique of fractionally over-inflating the tire (i.e., above the desired pressure setting) and then bleeding down the pressure to the desired value.

[0039] Any one or more features of any of the pressure verification and/or adjustment systems disclosed herein may be incorporated (alone or in combination) into any impact tool. The presently disclosed impact tools including pressure verification and/or adjustment systems provide a single tool that is capable of both installing/removing fasteners (e.g., wheel lug nuts) and verifying/adjusting air pressure (e.g., tire pressure). This will typically reduce the amount of time and the number of tools required to perform various tasks related to vehicle wheel and/or tire installation, by way of example. The implement holder **460** shown in FIG. 5 may further reduce the amount of time needed to perform such tasks because additional implements are immediately available to a user.

[0040] While certain illustrative embodiments have been described in detail in the figures and the foregoing description, such an illustration and description is to be considered as exemplary and not restrictive in character, it being understood that only illustrative embodiments have been shown and described and that all changes and modifications that come within the spirit of the disclosure are desired to be protected. There are a plurality of advantages of the present disclosure arising from the various features of the apparatus, systems, and methods described herein. It will be noted that alternative embodiments of the apparatus, systems, and methods of the present disclosure may not include all of the features described yet still benefit from at least some of the advantages of such features. Those of ordinary skill in the art may readily devise their own implementations of the apparatus, systems, and methods that incorporate one or more of the features of the present disclosure.

1. An impact tool comprising:
 - a housing;
 - an impact mechanism supported in the housing, the impact mechanism being configured to drive rotation of an output shaft about a first axis;
 - a motor supported in the housing, the motor being configured to drive the impact mechanism when energized; and
 - a pressure probe coupled to the housing, the pressure probe being configured to couple to a valve of a motor vehicle tire to measure an air pressure of the motor vehicle tire.
2. The impact tool of claim 1, further comprising a display supported by the housing, the display being configured to provide an indication of the air pressure of the motor vehicle tire measured by the pressure probe.
3. The impact tool of claim 1, wherein the housing includes a cavity formed therein, the cavity being configured to receive the pressure probe when not in use.
4. The impact tool of claim 3, wherein the pressure probe is rotatably mounted within the cavity such that the pressure probe is configured to be rotated out of the cavity for use.

5. The impact tool of claim 3, wherein the pressure probe includes a first arm rotatably mounted within the cavity and second arm rotatably mounted to the first arm.

6. The impact tool of claim 1, wherein the pressure probe is integrally formed as part of the housing.

7. The impact tool of claim 7, wherein the pressure probe extends along a second axis that is non-parallel to the first axis.

8. The impact tool of claim 1, wherein the pressure probe is further configured to adjust the air pressure of the motor vehicle tire.

9. The impact tool of claim 8, further comprising an air compressor supported in the housing and configured to be driven by the motor, the pressure probe being in fluid communication with the air compressor.

10. The impact tool of claim 8, wherein the impact tool is configured to be connected to an external source of pressurized air, the pressure probe being in selective fluid communication with the source of pressurized air.

11. The impact tool of claim 1, further comprising an implement holder coupled to the housing of the impact tool, the implement holder being configured to hold an implement that may be removably coupled to the output shaft.

12. The impact tool of claim 1, wherein the impact mechanism comprises:

an anvil coupled to the output shaft and configured to rotate about the first axis; and

a hammer configured to rotate about the first axis to periodically deliver an impact blow to the anvil to cause rotation thereof.

13. An impact tool comprising:

a housing;

a motor supported in the housing;

an output shaft supported by the housing, the output shaft configured to rotate about a first axis;

an impact mechanism supported in the housing, the impact mechanism comprising an anvil coupled to the output shaft and a hammer configured to rotate when driven by the motor to periodically deliver an impact blow to the anvil to cause rotation of the anvil and the output shaft;

a pressure probe coupled to the housing, the pressure probe being configured to couple to a valve of a motor vehicle tire to measure an air pressure of the motor vehicle tire; and

a display supported by the housing, the display being configured to provide an indication of the air pressure of the motor vehicle tire measured by the pressure probe.

14. The impact tool of claim 13, wherein the housing includes a cavity formed therein, the cavity being configured to receive the pressure probe when not in use.

15. The impact tool of claim 14, wherein the pressure probe is rotatably mounted within the cavity such that the pressure probe is configured to be rotated out of the cavity for use.

16. The impact tool of claim 14, wherein the pressure probe includes a first arm rotatably mounted within the cavity and second arm rotatably mounted to the first arm.

17. The impact tool of claim 13, wherein the pressure probe is integrally formed as part of the housing and extends along a second axis that is non-parallel to the first axis.

18. The impact tool of claim 13, wherein the pressure probe is further configured to adjust the air pressure of the motor vehicle tire.

19. The impact tool of claim 18, further comprising an air compressor supported in the housing and configured to be driven by the motor, the pressure probe being in fluid communication with the air compressor.

20. The impact tool of claim 18, wherein the impact tool is configured to be connected to an external source of pressurized air, the pressure probe being in selective fluid communication with the source of pressurized air.

* * * * *