



US 20200149556A1

(19) **United States**

(12) **Patent Application Publication**

Judge et al.

(10) **Pub. No.: US 2020/0149556 A1**

(43) **Pub. Date: May 14, 2020**

(54) **FLUID EXCHANGE DEVICES AND RELATED CONTROLS, SYSTEMS, AND METHODS**

Related U.S. Application Data

(60) Provisional application No. 62/758,366, filed on Nov. 9, 2018.

(71) Applicant: **FlowsERVE Management Company**, Irving, TX (US)

Publication Classification

(51) **Int. Cl.**
F04F 13/00 (2006.01)

(52) **U.S. Cl.**
CPC *F04F 13/00* (2013.01); *E21B 34/08* (2013.01)

(72) Inventors: **Scott Judge**, Bethlehem, PA (US); **Neil Havrilla**, Coplay, PA (US); **Nathan Terwilliger**, Bethlehem, PA (US); **Christopher Shages**, Bethlehem, PA (US); **A.K. Necioglu**, Macungie, PA (US)

(57) **ABSTRACT**

Pressure exchange devices, systems, and related methods may include a tank, a piston, a valve device, and one or more sensors for monitoring a position of the piston in the tank.

(21) Appl. No.: **16/678,998**

(22) Filed: **Nov. 8, 2019**

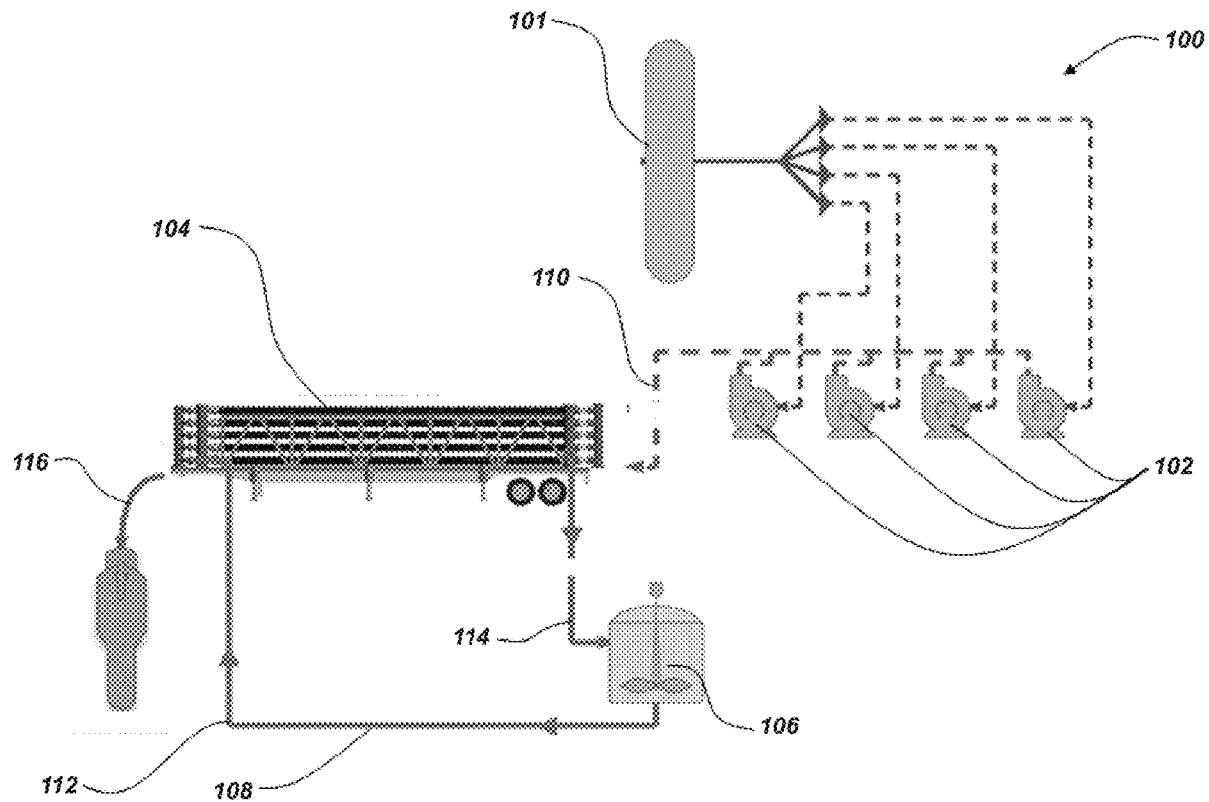

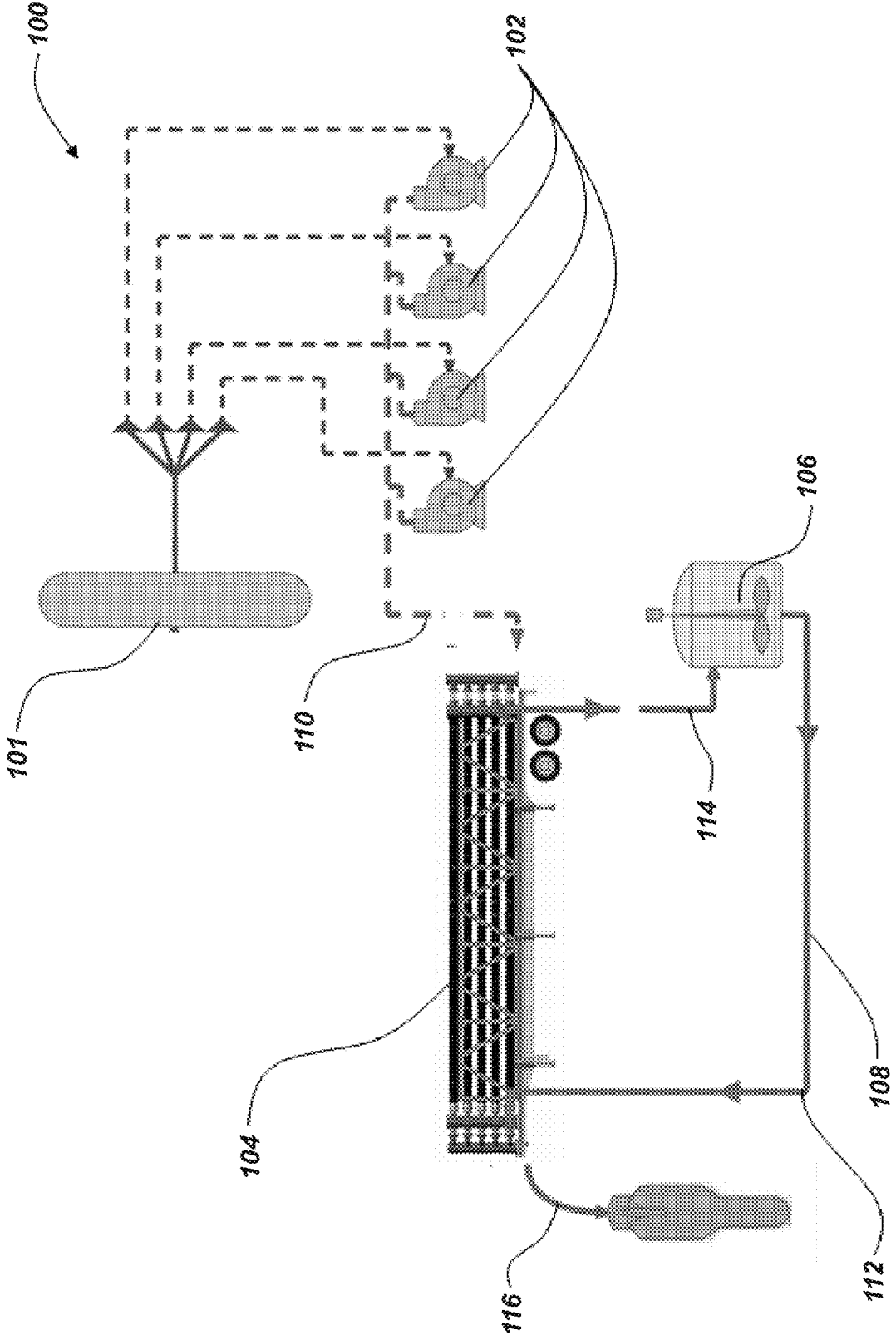

FIG. 1

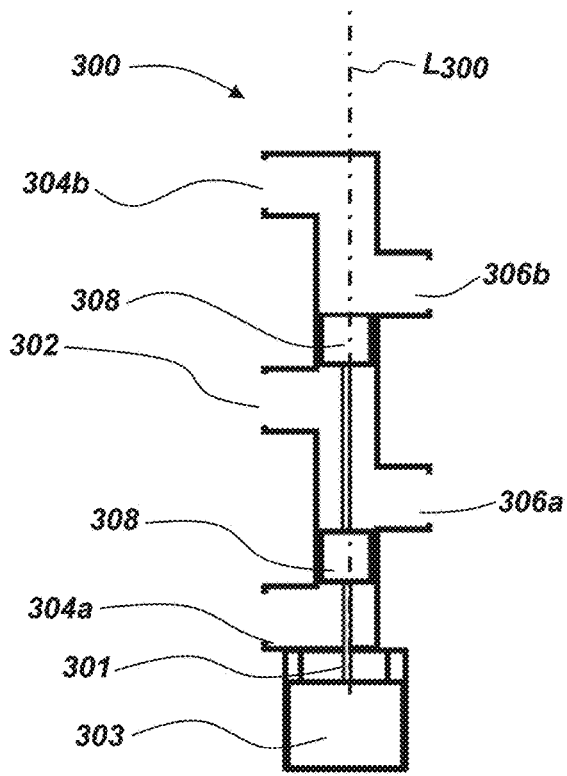

FIG. 3A

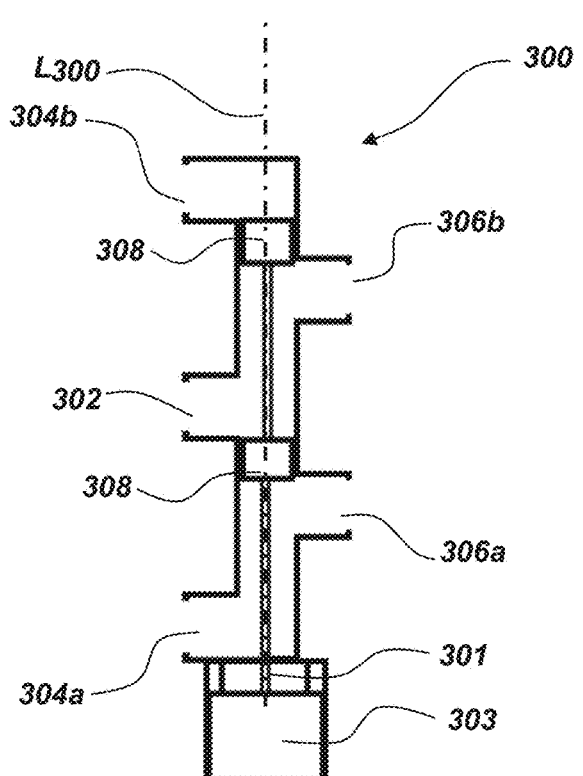

FIG. 3B

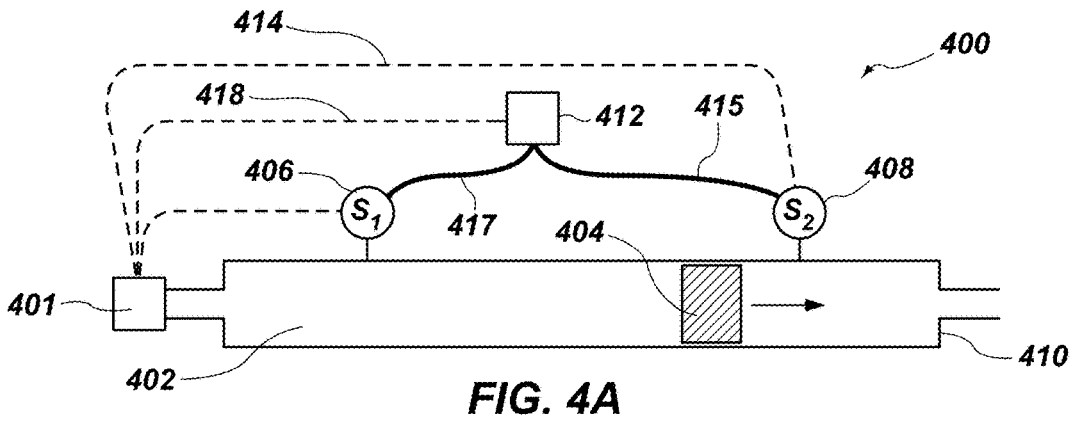

FIG. 4A

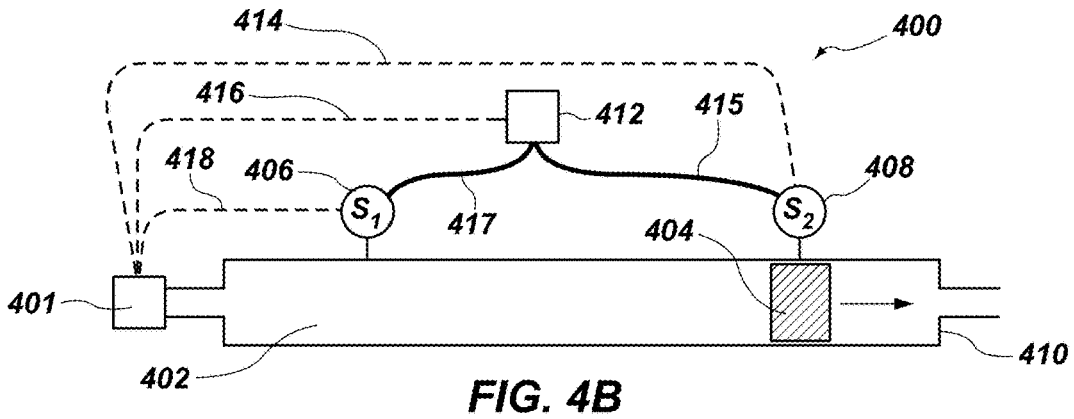

FIG. 4B

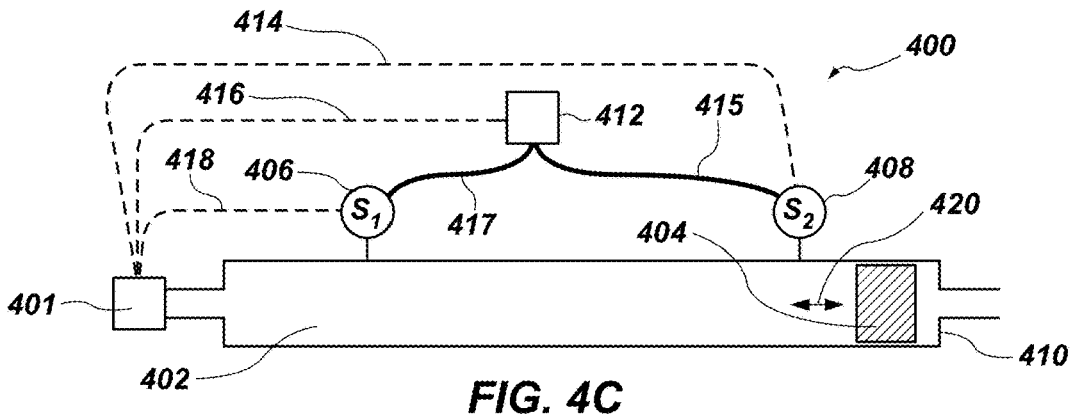

FIG. 4C

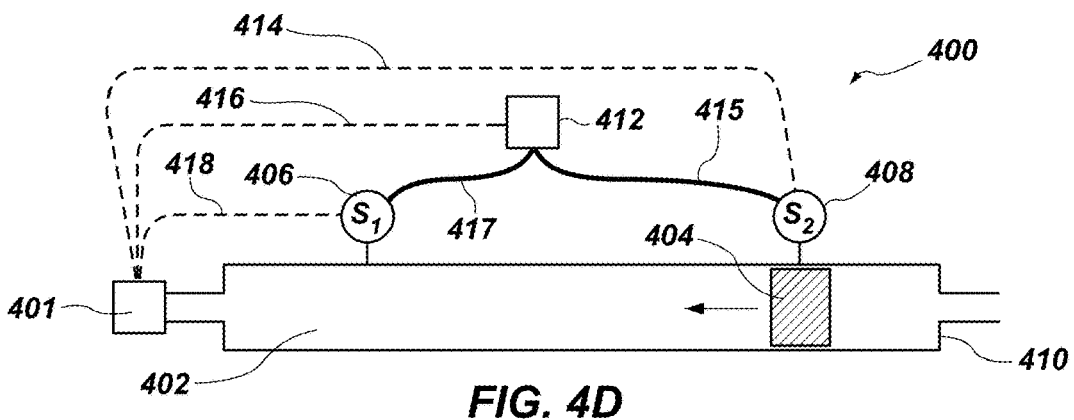

FIG. 4D

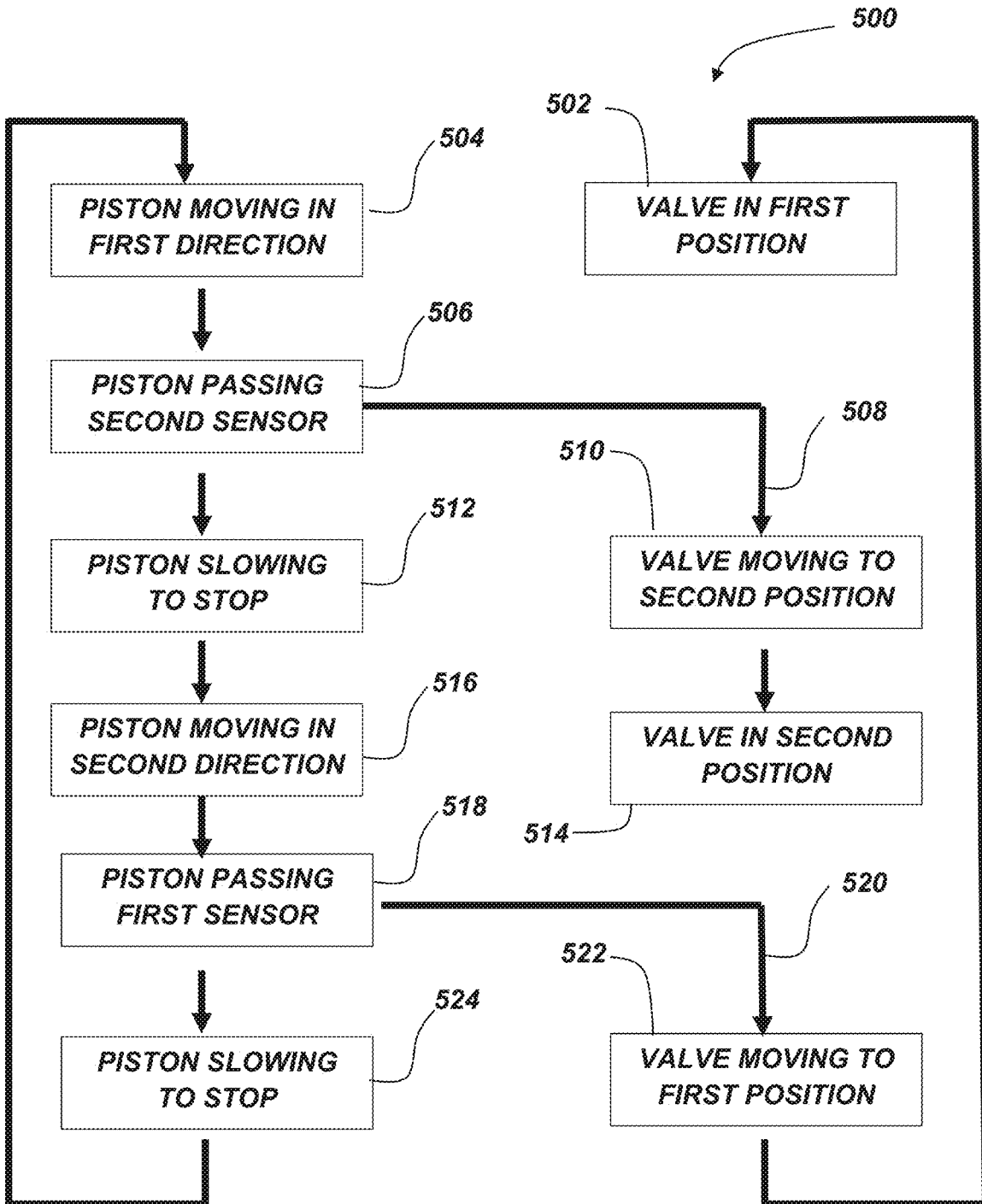

FIG. 5

FLUID EXCHANGE DEVICES AND RELATED CONTROLS, SYSTEMS, AND METHODS

CROSS-REFERENCE TO RELATED APPLICATION

[0001] This application claims the benefit under 35 U.S.C. § 119(e) of U.S. Provisional Patent Application Ser. No. 62/758,366, filed Nov. 9, 2018, for “Fluid Exchange Devices and Related Controls, Systems, and Method,” the disclosure of which is hereby incorporated herein in its entirety by this reference.

TECHNICAL FIELD

[0002] The present disclosure relates generally to exchange devices. More particularly, embodiments of the present disclosure relate to fluid exchange devices for one or more of exchanging properties (e.g., pressure) between fluids and systems and methods.

BACKGROUND

[0003] Industrial processes often involve hydraulic systems including pumps, valves, impellers, etc. Pumps, valves, and impellers may be used to control the flow of the fluids used in the hydraulic processes. For example, some pumps may be used to increase (e.g., boost) the pressure in the hydraulic system, other pumps may be used to move the fluids from one location to another. Some hydraulic systems include valves to control where a fluid flows. Valves may include control valves, ball valves, gate valves, globe valves, check valves, isolation valves, combinations thereof, etc.

[0004] Some industrial processes involve the use of caustic fluids, abrasive fluids, and/or acidic fluids. These types of fluids may increase the amount of wear on the components of a hydraulic system. The increased wear may result in increased maintenance and repair costs or require the early replacement of equipment. For example, abrasive, caustic, or acidic fluid may increase the wear on the internal components of a pump such as an impeller, shaft, vanes, nozzles, etc. Some pumps are rebuildable and an operation may choose to rebuild a worn pump replacing the worn parts which may result in extended periods of downtime for the worn pump resulting in either the need for redundant pumps or a drop in productivity. Other operations may replace worn pumps at a larger expense but a reduced amount of downtime.

[0005] Well completion operations in the oil and gas industry often involve hydraulic fracturing (often referred to as fracking or fracing) to increase the release of oil and gas in rock formations. Hydraulic fracturing involves pumping a fluid (e.g., frac fluid, fracking fluid, etc.) containing a combination of water, chemicals, and proppant (e.g., sand, ceramics) into a well at high pressures. The high pressures of the fluid increases crack size and crack propagation through the rock formation releasing more oil and gas, while the proppant prevents the cracks from closing once the fluid is depressurized. Fracturing operations use high-pressure pumps to increase the pressure of the fracking fluid. However, the proppant in the fracking fluid increases wear and maintenance on and substantially reduces the operation lifespan of the high-pressure pumps due to its abrasive nature.

BRIEF SUMMARY

[0006] Various embodiments may include a device for exchanging pressure between fluids. The device may include at least one tank, at least one piston, a valve device, and at least one sensor. The tank may include a first side (e.g., a clean side) for receiving a first fluid (e.g., clean fluid) at a higher pressure and a second side (e.g., a dirty side) for receiving a second fluid (e.g., downhole fluid, fracking fluid, drilling fluid) at a lower pressure. The piston may be in the tank. The piston may be configured to separate the clean fluid from the downhole fluid. The valve device may be configured to selectively place the clean fluid at the higher pressure in communication with the downhole fluid at the lower pressure through the piston to pressurize the downhole fluid to a second higher pressure. The sensor may be configured to detect a presence of the piston.

[0007] Another embodiment may include a device for exchanging at least one property between fluids. The device may include at least one tank, at least one piston, a valve device, and at least one sensor. The tank may include a first end for receiving a clean fluid with a first property and a second end for receiving a dirty fluid with a second property. The piston may be in the tank. The piston may be configured to separate the clean fluid from the dirty fluid. The valve device may be configured to selectively place the clean fluid in communication with the dirty fluid through the piston to transfer the first property of the clean fluid to the dirty fluid. The sensor may be configured to detect a position of the piston.

[0008] Another embodiment may include a system for exchanging pressure between at least two fluid streams. The system may include a pressure exchange device as described above, and at least one pump for supplying clean fluid to the pressure exchange device.

[0009] Another embodiment may include a method of controlling a pressure exchange device. The method may include supplying a high pressure fluid to a high pressure inlet of a valve configured to direct flow of the high pressure fluid to a chamber. A pressure may be transferred from the high pressure fluid to a dirty fluid through a piston in the chamber. A location of the piston may be monitored. A position of the valve may be changed responsive the location of the piston. Flow of the high pressure fluid may be redirected by the changing of the position of the valve.

BRIEF DESCRIPTION OF THE DRAWINGS

[0010] While the specification concludes with claims particularly pointing out and distinctly claiming what are regarded as embodiments of the present disclosure, various features and advantages of embodiments of the disclosure may be more readily ascertained from the following description of example embodiments of the disclosure when read in conjunction with the accompanying drawings, in which:

[0011] FIG. 1 is schematic view of a hydraulic fracturing system according to an embodiment of the present disclosure;

[0012] FIG. 2 is cross-sectional view of a fluid exchanger device according to an embodiment of the present disclosure;

[0013] FIG. 3A is a cross-sectional view of a control valve in a first position according to an embodiment of the present disclosure;

[0014] FIG. 3B is a cross-sectional view of a control valve in a second position according to an embodiment of the present disclosure;

[0015] FIG. 4A is a cross-sectional view of a chamber in a first position according to an embodiment of the present disclosure;

[0016] FIG. 4B is a cross-sectional view of a chamber in a second position according to an embodiment of the present disclosure;

[0017] FIG. 4C is a cross-sectional view of a chamber in a third position according to an embodiment of the present disclosure;

[0018] FIG. 4D is a cross-sectional view of a chamber in a fourth position according to an embodiment of the present disclosure; and

[0019] FIG. 5 is a flow diagram of a control process for an embodiment of a fluid exchanger according to the present disclosure.

DETAILED DESCRIPTION

[0020] The illustrations presented herein are not meant to be actual views of any particular fluid exchanger or component thereof, but are merely idealized representations employed to describe illustrative embodiments. The drawings are not necessarily to scale. Elements common between figures may retain the same numerical designation.

[0021] As used herein, relational terms, such as “first,” “second,” “top,” “bottom,” etc., are generally used for clarity and convenience in understanding the disclosure and accompanying drawings and do not connote or depend on any specific preference, orientation, or order, except where the context clearly indicates otherwise.

[0022] As used herein, the term “and/or” means and includes any and all combinations of one or more of the associated listed items.

[0023] As used herein, the terms “vertical” and “lateral” refer to the orientations as depicted in the figures.

[0024] As used herein, the term “substantially” or “about” in reference to a given parameter means and includes to a degree that one skilled in the art would understand that the given parameter, property, or condition is met with a small degree of variance, such as within acceptable manufacturing tolerances. For example, a parameter that is substantially met may be at least 90% met, at least 95% met, at least 99% met, or even 100% met.

[0025] As used herein, the term “fluid” may mean and include fluids of any type and composition. Fluids may take a liquid form, a gaseous form, or combinations thereof, and, in some instances, may include some solid material. In some embodiments, fluids may convert between a liquid form and a gaseous form during a cooling or heating process as described herein. In some embodiments, the term fluid includes gases, liquids, and/or pumpable mixtures of liquids and solids.

[0026] Embodiments of the present disclosure may relate to exchange devices that may be utilized to exchange one or more properties between fluids (e.g., a pressure exchanger). Such exchangers (e.g., pressure exchangers) are sometimes called “flow-work exchangers” or “isobaric devices” and are machines for exchanging pressure energy from a relatively high-pressure flowing fluid system to a relatively low-pressure flowing fluid system.

[0027] In some industrial processes, elevated pressures are required in certain parts of the operation to achieve the

desired results, following which the pressurized fluid is depressurized. In other processes, some fluids used in the process are available at high-pressures and others at low-pressures, and it is desirable to exchange pressure energy between these two fluids. As a result, in some applications, great improvement in economy can be realized if pressure can be efficiently transferred between two fluids.

[0028] In some embodiments, exchangers as disclosed herein may be similar to and include the various components and configurations of the pressure exchangers disclosed in U.S. Pat. No. 5,797,429 to Shumway, issued Aug. 25, 1998, the disclosure of which is hereby incorporated herein in its entirety by this reference.

[0029] Although some embodiments of the present disclosure are depicted as being used and employed as a pressure exchanger between two or more fluids, persons of ordinary skill in the art will understand that the embodiments of the present disclosure may be employed in other implementations such as, for example, the exchange of other properties (e.g., temperature, density, etc.) and/or composition between one or more fluids and/or mixing of two or more fluids.

[0030] In some embodiments, a pressure exchanger may be used to protect moving components (e.g., pumps, valves, impellers, etc.) in processes where high pressures are needed in a fluid that has the potential to damage the moving components (e.g., abrasive fluid, caustic fluid, acidic fluid, etc.).

[0031] For example, pressure exchange devices according to embodiments of the disclosure may be implemented in hydrocarbon related processes, such as, hydraulic fracturing or other drilling operations (e.g., subterranean downhole drilling operations).

[0032] As discussed above, well completion operations in the oil and gas industry often involve hydraulic fracturing, drilling operations, or other downhole operations that use high-pressure pumps to increase the pressure of the downhole fluid (e.g., fluid that is intended to be conducted into a subterranean formation or borehole, such as, fracking fluid, drilling fluid, drilling mud). The proppants, chemicals, additives to produce mud, etc. in these fluids often increase wear and maintenance on the high-pressure pumps.

[0033] In some embodiments, a hydraulic fracturing system may include a hydraulic energy transfer system that transfers pressure between a first fluid (e.g., a clean fluid, such as a partially (e.g., majority) or substantially proppant free fluid or a pressure exchange fluid) and a second fluid (e.g., fracking fluid, such as a proppant-laden fluid, an abrasive fluid, or a dirty fluid). Such systems may at least partially (e.g., substantially, primarily, entirely) isolate the high-pressure first fluid from the second dirty fluid while still enabling the pressurizing of the second dirty fluid with the high-pressure first fluid and without having to pass the second dirty fluid directly through a pump or other pressurizing device.

[0034] While some embodiments discussed herein may be directed to fracking operations, in additional embodiments, the exchanger systems and devices disclosed herein may be utilized in other operations. For example, devices, systems, and/or method disclosed herein may be used in other downhole operations, such as, for example, downhole drilling operations.

[0035] FIG. 1 illustrates a system diagram of an embodiment of hydraulic fracturing system 100 utilizing a pressure exchanger between a first fluid stream (e.g., clean fluid

stream) and a second fluid stream (e.g., a fracking fluid stream). Although not explicitly described, it should be understood that each component of the system **100** may be directly connected or coupled via a fluid conduit (e.g., pipe) to an adjacent (e.g., upstream or downstream) component. The hydraulic fracturing system **100** may include one or more devices for pressurizing the first fluid stream, such as, for example, frack pumps **102** (e.g., reciprocating pumps, centrifugal pumps, scroll pumps, etc.). The system **100** may include multiple frack pumps **102**, such as at least two frack pumps **102**, at least four frack pumps **102**, at least ten frack pumps **102**, at least sixteen frack pumps, or at least twenty frack pumps **102**. In some embodiments, the frack pumps **102** may provide relatively and substantially clean fluid at a high pressure to a pressure exchanger **104** from a fluid source **101**. In some embodiments, fluid may be provided separately to each pump **102** (e.g., in a parallel configuration). After pressurization in the pumps **102**, the high pressure clean fluid **110** may be combined and transmitted to the pressure exchanger **104** (e.g., in a serial configuration).

[0036] As used herein, “clean” fluid may describe fluid that is at least partially or substantially free (e.g., substantially entirely or entirely free) of chemicals and/or proppants typically found in a downhole fluid and “dirty” fluid may describe fluid that at least partially contains chemicals, other additives, and/or proppants typically found in a downhole fluid.

[0037] The pressure exchanger **104** may transmit the pressure from the high pressure clean fluid **110** to a low pressure fracking fluid (e.g., fracking fluid **112**) in order to provide a high pressure fracking fluid **116**. The clean fluid may be expelled from the pressure exchanger **104** as a low pressure fluid **114** after the pressure is transmitted to the low pressure fracking fluid **112**. In some embodiments, the low pressure fluid **114** may be an at least partially or substantially clean fluid that substantially lacks chemicals and/or proppants aside from a small amount that may be passed to the low pressure fluid **114** from the fracking fluid **112** in the pressure exchanger **104**.

[0038] In some embodiments, the pressure exchanger **104** may include one or more pressure exchanger devices (e.g., operating in parallel). In such configurations, the high pressure inputs may be separated and provided to inputs of each of the pressure exchanger devices. The outputs of each of the pressure exchanger devices may be combined as the high pressure fracking fluid exits the pressure exchanger **104**. For example, and as discussed below with reference to FIG. 4, the pressure exchanger **104** may include two or more (e.g., three) pressure exchanger devices operating in parallel. As depicted, the pressure exchanger **104** may be provided on a mobile platform (e.g., a truck trailer) that may be relatively easily installed and removed from a fracking well site.

[0039] After being expelled from the pressure exchanger **104**, the low pressure clean fluid **114** may travel to and be collected in a mixing chamber **106** (e.g., blender unit, mixing unit, etc.). In some embodiments, the low pressure fluid **114** may be converted (e.g., modified, transformed, etc.) to the low pressure fracking fluid **112** in the mixing chamber **106**. For example, a proppant may be added to the low pressure clean fluid **114** in the mixing chamber **106** creating a low pressure fracking fluid **112**. In some embodiments, the low pressure clean fluid **114** may be expelled as waste.

[0040] In many hydraulic fracturing operations, a separate process may be used to heat the fracking fluid **112** before the fracking fluid **112** is discharged downhole (e.g., to ensure proper blending of the proppants in the fracking fluid). In some embodiments, using the low pressure clean fluid **114** to produce the fracking fluid **112** may eliminate the step of heating the fracking fluid. For example, the low pressure clean fluid **114** may be at an already elevated temperature as a result of the fracking pumps **102** pressurizing the high pressure clean fluid **110**. After transferring the pressure in the high pressure clean fluid **110** that has been heated by the pumps **102**, the now low pressure clean fluid **114** retains at least some of that heat energy as it is passed out of the pressure exchanger **104** to the mixing chamber **106**. In some embodiments, using the low pressure clean fluid **114** at an already elevated temperature to produce the fracking fluid may result in the elimination of the heating step for the fracking fluid. In other embodiments, the elevated temperature of the low pressure clean fluid **114** may result in a reduction of the amount of heating required for the fracking fluid.

[0041] After the proppant is added to the low pressure fluid **114**, now fracking fluid, the low pressure fracking fluid **112** may be expelled from the mixing chamber **106**. The low pressure fracking fluid **112** may then enter the pressure exchanger **104** on the fracking fluid end through a fluid conduit **108** connected (e.g., coupled) between the mixing chamber **106** and the pressure exchanger **104**. Once in the pressure exchanger **104**, the low pressure fracking fluid **112** may be pressurized by the transmission of pressure from the high pressure clean fluid **110** through the pressure exchanger **104**. The high pressure fracking fluid **116** may then exit the pressure exchanger **104** and be transmitted downhole.

[0042] Hydraulic fracturing systems generally require high operating pressures for the high pressure fracking fluid **116**. In some embodiments, the desired pressure for the high pressure fracking fluid **116** may be between about 8,000 PSI (55,158 kPa) and about 12,000 PSI (82,737 kPa), such as between about 9,000 PSI (62,052 kPa) and about 11,000 PSI (75,842 kPa), or about 10,000 PSI (68,947 kPa).

[0043] In some embodiments, the high pressure clean fluid **110** may be pressurized to a pressure at least substantially the same or slightly greater than the desired pressure for the high pressure fracking fluid **116**. For example, the high pressure clean fluid **110** may be pressurized to between about 0 PSI (0 kPa) and about 1000 PSI (6,894 kPa) greater than the desired pressure for the high pressure fracking fluid **116**, such as between about 200 PSI (1,379 kPa) and about 700 PSI (4,826 kPa) greater than the desired pressure, or between about 400 PSI (2,758 kPa) and about 600 PSI (4,137 kPa) greater than the desired pressure, to account for any pressure loss during the pressure and exchange process.

[0044] FIG. 2 illustrates an embodiment of a pressure exchanger **200**. The pressure exchanger **200** may be a linear pressure exchanger in the sense that it is operated by moving or translating an actuation assembly substantially along a linear path. For example, the actuation assembly may be moved linearly to selectively place the low and high pressure fluids in at least partial communication (e.g., indirect communication where the pressure of the high pressure fluid may be transferred to the low pressure fluid) as discussed below in greater detail.

[0045] The linear pressure exchanger **200** may include one or more (e.g., two) chambers **202a**, **202b** (e.g., tanks,

collectors, cylinders, tubes, pipes, etc.). The chambers **202a**, **202b** (e.g., parallel chambers **202a**, **202b**) may include pistons **204a**, **204b** configured to substantially maintain the high pressure clean fluid **210** and low pressure clean fluid **214** (e.g., the clean side) separate from the high pressure dirty fluid **216** and the low pressure dirty fluid **212** (e.g., the dirty side) while enabling transfer of pressure between the respective fluids **210**, **212**, **214**, and **216**. The pistons **204a**, **204b** may be sized (e.g., the outer diameter of the pistons **204a**, **204b** relative to the inner diameter of the chambers **202a**, **202b**) to enable the pistons **204a**, **204b** to travel through the chamber **202a**, **202b** while minimizing fluid flow around the pistons **204a**, **204b**.

[0046] The linear pressure exchanger **200** may include a clean control valve **206** configured to control the flow of high pressure clean fluid **210** and low pressure clean fluid **214**. Each of the chambers **202a**, **202b** may include one or more dirty control valves **207a**, **207b**, **208a**, and **208b** configured to control the flow of the low pressure dirty fluid **212** and the high pressure dirty fluid **216**.

[0047] While the embodiment of FIG. 2 contemplates a linear pressure exchanger **200**, other embodiments, may include other types of pressure exchangers that involve other mechanisms for selectively placing the low and high pressure fluids in at least partial communication (e.g., a rotary actuator such as those disclosed in U.S. Pat. No. 9,435,354, issued Sep. 6, 2016, the disclosure of which is hereby incorporated herein in its entirety by this reference, etc.).

[0048] In some embodiments, the clean control valve **206**, which includes an actuation stem **203** that moves one or more stoppers **308** along (e.g., linearly along) a body **205** of the valve **206**, may selectively allow (e.g., input, place, etc.) high pressure clean fluid **210** provided from a high pressure inlet port **302** to enter a first chamber **202a** on a clean side **220a** of the piston **204a**. The high pressure clean fluid **210** may act on the piston **204a** moving the piston **204a** in a direction toward the dirty side **221a** of the piston **204a** and compressing the dirty fluid in the first chamber **202a** to produce the high pressure dirty fluid **216**. The high pressure dirty fluid **216** may exit the first chamber **202a** through the dirty discharge control valve **208a** (e.g., outlet valve, high pressure outlet). At substantially the same time, the low pressure dirty fluid **212** may be entering the second chamber **202b** through the dirty fill control valve **207b** (e.g., inlet valve, low pressure inlet). The low pressure dirty fluid **212** may act on the dirty side **221b** of the piston **204b** moving the piston **204b** in a direction toward the clean side **220b** of the piston **204b** within the second chamber **202b**. The low pressure clean fluid **214** may be discharged (e.g., emptied, expelled, etc.) through the clean control valve **206** as the piston **204b** moves in a direction toward the clean side **220b** of the piston **204b** reducing the space on the clean side **220b** of the piston **204b** within the second chamber **202b**. A cycle of the pressure exchanger is completed once each piston **204a**, **204b** moves the substantial length (e.g., the majority of the length) of the respective chamber **202a**, **202b** (which "cycle" may be a half cycle with the piston **204a**, **204b** moving in one direction along the length of the chamber **202a**, **202b** and a full cycle includes the piston **204a**, **204b** moving in the one direction along the length of the chamber **202a**, **202b** and then moving in the other direction to return to substantially the original position). In some embodiments, only a portion of the length may be utilized (e.g., in reduced capacity situations). Upon the completion of a cycle, the

actuation stem **203** of the clean control valve **206** may change positions enabling the high pressure clean fluid **210** to enter the second chamber **202b**, thereby changing the second chamber **202b** to a high pressure chamber and changing the first chamber **202a** to a low pressure chamber and repeating the process.

[0049] In some embodiments, each chamber **202a**, **202b** may have a higher pressure on one side of the pistons **204a**, **204b** to move the piston in a direction away from the higher pressure. For example, the high pressure chamber may experience pressures between about 8,000 PSI (55,158 kPa) and about 13,000 PSI (89,632 kPa) with the highest pressures being in the high pressure clean fluid **210** to move the piston **204a**, **204b** away from the high pressure clean fluid **210** compressing and discharging the dirty fluid to produce the high pressure dirty fluid **216**. The low pressure chamber **202a**, **202b** may experience much lower pressures, relatively, with the relatively higher pressures in the currently low pressure chamber **202a**, **202b** still being adequate enough in the low pressure dirty fluid **212** to move the piston **204a**, **204b** in a direction away from the low pressure dirty fluid **212** discharging the low pressure clean fluid **214**. In some embodiments, the pressure of the low pressure dirty fluid **212** may be between about 100 PSI (689 kPa) and about 700 PSI (4,826 kPa), such as between about 200 PSI (1,379 kPa) and about 500 PSI (3,447 kPa), or between about 300 PSI (2,068 kPa) and about 400 PSI (2,758 kPa).

[0050] Referring back to FIG. 1, in some embodiments, the system **100** may include an optional device (e.g., a pump) to pressurize the low pressure dirty fluid **212** (e.g., to a pressure level that is suitable to move the piston **204a**, **204b** toward the clean side) as it is being provided into the chambers **202a**, **202b**.

[0051] Referring again to FIG. 2, if any fluid pushes past the piston **204a**, **204b** (e.g., leak by, blow by, etc.) it will generally tend to flow from the higher pressure fluid to the lower pressure fluid. The high pressure clean fluid **210** may be maintained at the highest pressure in the system such that the high pressure clean fluid **210** may not generally become substantially contaminated. The low pressure clean fluid **214** may be maintained at the lowest pressure in the system. Therefore, it is possible that the low pressure clean fluid **214** may become contaminated by the low pressure dirty fluid **212**. In some embodiments, the low pressure clean fluid **214** may be used to produce the low pressure dirty fluid **212** substantially nullifying any detriment resulting from the contamination. Likewise, any contamination of the high pressure dirty fluid **216** by the high pressure clean fluid **210** would have minimal effect on the high pressure dirty fluid **216**.

[0052] In some embodiments, the dirty control valves **207a**, **207b**, **208a**, **208b** may be check valves (e.g., clack valves, non-return valves, reflux valves, retention valves, or one-way valves). For example, one or more of the dirty control valves **207a**, **207b**, **208a**, **208b** may be a ball check valve, diaphragm check valve, swing check valve, tilting disc check valve, clapper valve, stop-check valve, lift-check valve, in-line check valve, duckbill valve, etc. In additional embodiments, one or more of the dirty control valves **207a**, **207b**, **208a**, **208b** may be actuated valves (e.g., solenoid valves, pneumatic valves, hydraulic valves, electronic valves, etc.) configured to receive a signal from a controller and open or close responsive the signal.

[0053] The dirty control valves **207a**, **207b**, **208a**, **208b** may be arranged in opposing configurations such that when the chamber **202a**, **202b** is in the high pressure configuration the high pressure dirty fluid opens the dirty discharge control valve **208a**, **208b** while the pressure in the chamber **202a**, **202b** holds the dirty fill control valve **207a**, **207b** closed. For example, the dirty discharge control valve **208a**, **208b** comprises a check valve that opens in a first direction out of the chamber **202a**, **202b**, while the dirty fill control valve **207a**, **207b** comprises a check valve that opens in a second, opposing direction into the chamber **202a**, **202b**.

[0054] The dirty discharge control valves **208a**, **208b** may be connected to a downstream element (e.g., a fluid conduit, a separate or common manifold) such that the high pressure in the downstream element holds the dirty discharge valve **208a**, **208b** closed in the chamber **202a**, **202b** that is in the low pressure configuration. Such a configuration enables the low pressure dirty fluid to open the dirty fill control valve **207a**, **207b** and enter the chamber **202a**, **202b**.

[0055] FIGS. 3A and 3B illustrate a cross sectional view of an embodiment of a clean control valve **300** at two different positions. In some embodiments, the clean control valve **300** may be similar to the control valve **206** discussed above. The clean control valve **300** may be a multiport valve (e.g., 4 way valve, 5 way valve, LinX® valve, etc.). The clean control valve **300** may have one or more high pressure inlet ports (e.g., one port **302**), one or more low pressure outlet ports (e.g., two ports **304a**, **304b**), and one or more chamber connection ports (e.g., two ports **306a**, **306b**). The clean control valve **300** may include at least two stoppers **308** (e.g., plugs, pistons, discs, valve members, etc.). In some embodiments, the clean control valve **300** may be a linearly actuated valve. For example, the stoppers **308** may be linearly actuated such that the stoppers **308** move along a substantially straight line (e.g., along a longitudinal axis L_{300} of the clean control valve **300**).

[0056] The clean control valve **300** may include an actuator **303** configured to actuate the clean control valve **300** (e.g., an actuator coupled to a valve stem **301** of the clean control valve **300**). In some embodiments, the actuator **303** may be electronic (e.g., solenoid, rack and pinion, ball screw, segmented spindle, moving coil, etc.), pneumatic (e.g., tie rod cylinders, diaphragm actuators, etc.), or hydraulic. In some embodiments, the actuator **303** may enable the clean control valve **300** to move the valve stem **301** and stoppers **308** at variable rates (e.g., changing speeds, adjustable speeds, etc.).

[0057] FIG. 3A illustrates the clean control valve **300** in a first position. In the first position, the stoppers **308** may be positioned such that the high pressure clean fluid may enter the clean control valve **300** through the high pressure inlet port **302** and exit into a first chamber through the chamber connection port **306a**. In the first position, the low pressure clean fluid may travel through the clean control valve **300** between the chamber connection port **306b** and the low pressure outlet port **304b** (e.g., may exit through the low pressure outlet port **304b**).

[0058] FIG. 3B illustrates the clean control valve **300** in a second position. In the second position, the stoppers **308** may be positioned such that the high pressure clean fluid may enter the clean control valve **300** through the high pressure inlet port **302** and exit into a second chamber through the chamber connection port **306b**. The low pressure clean fluid may travel through the clean control valve **300**

between the chamber connection port **306a** and the low pressure outlet port **304a** (e.g., may exit through the low pressure outlet port **304a**).

[0059] Now referring to FIGS. 2, 3A, and 3B, the clean control valve **206** is illustrated in the first position with the high pressure inlet port **302** connected to the chamber connection port **306a** providing high pressure clean fluid to the first chamber **202a**. Upon completion of the cycle, the clean control valve **206** may move the stoppers **308** to the second position thereby connecting the high pressure inlet port **302** to the second chamber **202b** through the chamber connection port **306b**.

[0060] In some embodiments, the clean control valve **206** may pass through a substantially fully closed position in the middle portion of a stroke between the first position and the second position. For example, in the first position, the stoppers **308** may maintain a fluid pathway between the high pressure inlet port **302** and the chamber connection port **306a** and a fluid pathway between the chamber connection port **306b** and the low pressure outlet port **304b**. In the second position, the stoppers **308** may maintain a fluid pathway between the high pressure inlet port **302** and the chamber connection port **306b** and a fluid pathway between the chamber connection port **306a** and the low pressure outlet port **304a**. Transitioning between the first and second positions may involve at least substantially closing both fluid pathways to change the connection of the chamber connection port **306a** from the high pressure inlet port **302** to the low pressure outlet port **304a** and to change the connection of the chamber connection port **306b** from the low pressure outlet port **304b** to the high pressure inlet port **302**. The fluid pathways may at least substantially close at a middle portion of the stroke to enable the change of connections.

[0061] Opening and closing valves, where fluids are operating at high pressures, may result in pressure pulsations (e.g., water hammer) that can result in damage to components in the system when high pressure is suddenly introduced or removed from the system. As a result, pressure pulsations may occur in the middle portion of the stroke when the fluid pathways are closing and opening respectively.

[0062] In some embodiments, the actuator **303** may be configured to move the stoppers **308** at variable speeds along the stroke of the clean control valve **206**. As the stoppers **308** move from the first position to the second position, the stoppers **308** may move at a high rate of speed while traversing a first portion of the stroke that does not involve newly introducing flow from the high pressure inlet port **302** into the chamber connection ports **306a**, **306b**. The stoppers **308** may decelerate to a low rate of speed as the stoppers **308** approach a closed position (e.g., when the stoppers **308** block the chamber connection ports **306a**, **306b** during the transition between the high pressure inlet port **302** connection and the low pressure outlet port **304a**, **304b** connection) at a middle portion of the stroke. The stoppers **308** may continue at a lower rate of speed, as the high pressure inlet port **302** is placed into communication with one of the chamber connection ports **306a**, **306b**. After, traversing the chamber connection ports **306a**, **306b**, the stoppers **308** may accelerate to another high rate of speed as the stoppers **308** approach the second position. The low rate of speed in the middle portion of the stroke may reduce the speed that the clean control valve **206** opens and closes enabling the clean

control valve to gradually introduce and/or remove the high pressure from the chambers 202a, 202b.

[0063] In some embodiments, the motion of the pistons 204a, 204b may be controlled by regulating the rate of fluid flow (e.g., of the incoming fluid) and/or a pressure differential between the clean side 220a, 220b of the pistons 204a, 204b, and the dirty side 221a, 221b of the pistons 204a, 204b at least partially with the movement of the clean control valve 206. In some embodiments, it may be desirable for the piston 204a, 204b in the low pressure chamber 202a, 202b to move at substantially the same speed as the piston 204a, 204b in the high pressure chamber 202a, 202b either by manipulating their pressure differentials in each chamber and/or by controlling the flow rates of the fluid in and out of the chambers 202a, 202b. However, the piston 204a, 204b in the low pressure chamber 202a, 202b may tend to move at a greater speed than the piston 204a, 204b in the high pressure chamber 202a, 202b.

[0064] In some embodiments, the rate of fluid flow and/or the pressure differential may be varied to control acceleration and deceleration of the pistons 204a, 204b (e.g., by manipulating and/or varying the stroke of the clean control valve 206 and/or by manipulating the pressure in the fluid streams with one or more pumps). For example, increasing the flow rate and/or the pressure of the high pressure clean fluid 210 when the piston 204a, 204b is near a clean end 224 of the chamber 202a, 202b at the beginning of the high pressure stroke may increase the rate of fluid flow and/or the pressure differential in the chamber 202a, 202b. Increasing the rate of fluid flow and/or the pressure differential may cause the piston 204a, 204b to accelerate to or move at a faster rate. In another example, the flow rate and/or the pressure of the high pressure clean fluid 210 may be decreased when the piston 204a, 204b approaches a dirty end 226 of the chamber 202a, 202b at the end of the high pressure stroke. Decreasing the rate of fluid flow and/or the pressure differential may cause the piston 204a, 204b to decelerate and/or stop before reaching the dirty end of the respective chamber 202a, 202b.

[0065] Similar control with the stroke of the clean control valve 206 may be utilized to prevent the piston 204a, 204b from traveling to the furthest extent of the clean end of the chambers 202a, 202b. For example, the clean control valve 206 may close off one of the chamber connection ports 306a, 306b before the piston 204a, 204b contacts the furthest extent of the clean end of the chambers 202a, 202b by preventing any further fluid flow and slowing and/or stopping the piston 204a, 204b. In some embodiments, the clean control valve 206 may open one of the chamber connection ports 306a, 306b into communication with the high pressure inlet port 302 before the piston 204a, 204b contacts the furthest extent of the clean end of the chambers 202a, 202b in order to slow, stop, and/or reverse the motion of the piston 204a, 204b.

[0066] If the pistons 204a, 204b reach the clean end 224 or dirty end 226 of the respective chambers 202a, 202b the higher pressure fluid may bypass the piston 204a, 204b and mix with the lower pressure fluid. In some embodiments, mixing the fluids may be desirable. For example, if the pistons 204a, 204b reach the dirty end 226 of the respective chambers 202a, 202b during the high pressure stroke, the high pressure clean fluid 210 may bypass the piston 204a, 204b (e.g., by traveling around the piston 204a, 204b or through a valve in the piston 204a, 204b) flushing any

residual contaminants from the surfaces of the piston 204a, 204b. In some embodiments, mixing the fluids may be undesirable. For example, if the pistons 204a, 204b reach the clean end 224 of the respective chambers 202a, 202b during the low pressure stroke, the low pressure dirty fluid 212 may bypass the piston 204a, 204b and mix with the low pressure clean fluid contaminating the clean area in the clean control valve 206 with the dirty fluid.

[0067] In some embodiments, the system 100 may prevent the pistons 204a, 204b from reaching the clean end 224 of the respective chambers 202a, 202b. For example, the clean control valve 206 may include a control device 207 (e.g., sensor, safety, switch, etc.) to trigger the change in position of the clean control valve 206 on detecting the approach of the piston 204a, 204b to the clean end 224 of the respective chamber 202a, 202b such that the system 100 may utilize the clean control valve 206 to change flow path positions before the piston 204a, 204b reaches the clean end 224 of the chamber 202a, 202b.

[0068] In some embodiments, the system 100 may be configured to enable the pistons 204a, 204b to reach the dirty end 226 of the respective chambers 202a, 202b during the high pressure stroke. In some embodiments, the clean control valve 206 may include a control device 207 to trigger the change in position of the clean control valve 206 on detecting the approach of the piston 204a, 204b to the dirty end 226 of the respective chamber 202a, 202b. In some embodiments, the control device may be configured such that the control valve 206 does not complete the change in direction of the piston 204a, 204b until the piston 204a, 204b has reached the furthest extent of the dirty end 226 of the respective chamber 202a, 202b. In some embodiments, the control device may include a time delay through programming or mechanical delay that enables the piston 204a, 204b to reach the furthest extent of the dirty end 226 of the chamber 202a, 202b.

[0069] In some embodiments, the system 100 may be configured to enable the pistons 204a, 204b to reach the dirty end 226 of the respective chambers 202a, 202b during the high pressure stroke and prevent the pistons 204a, 204b from reaching the clean end 224 of the respective chambers 202a, 202b during the low pressure stroke. For example, the system 100 may drive both of the pistons 204a, 204b a select distance through the respective chambers 202a, 202b where the pistons 204a, 204b is maintained a select distance from the clean end 224 while enabling the pistons 204a, 204b to travel relatively closer to or come in contact with, the dirty end 226. In some embodiments, the system 100 may be configured such that the rate of fluid flow and/or the pressure differential across the piston 204a, 204b in the low pressure chamber 202a, 202b may be less than the rate of fluid flow and/or the pressure differential across the piston 204a, 204b in the high pressure chamber 202a, 202b such that the piston 204a, 204b travels slower during the low pressure cycle than the high pressure cycle.

[0070] In some embodiments, the control device 207 may be configured to trigger the change in position of the clean control valve 206 on detecting the approach of the piston 204a, 204b to the clean end 224 of the respective chamber 202a, 202b such that the clean control valve 206 may change positions before the piston 204a, 204b reaches the clean end 224 of the chamber 202a, 202b. In some embodiments, the control device 207 may be configured to trigger the change in position of the clean control valve 206 on detecting the

approach of the piston **204a**, **204b** to the dirty end **226** of the respective chamber **202a**, **202b**. In some embodiments, the control device may be configured to trigger the change in position of the clean control valve **206** by evaluating both of the pistons **204a**, **204b** as they respectively approach the clean end **224** and the dirty end **226** of the chambers **202a**, **202b**. For example, the control device **207** may detect the approach of the piston **204a**, **204b** to the dirty end **226** of the chamber **202a**, **202b** and begin a timer (e.g., mechanical timer, electronic timer, programmed time delay, etc.) If the control device **207** detects the approach of the piston **204a**, **204b** to the clean end **224** of the chamber **202a**, **202b** before the time triggers the change in position of the clean control valve **206**, the control device **207** may override the timer and change the position of the clean control valve **206** to prevent the piston **204a**, **204b** from reaching the clean end **224** of the chamber **202a**, **202b**.

[0071] In some embodiments, an automated controller may produce signals that may be transmitted to the clean control valve **206** directing the clean control valve **206** to move from the first position to the second position or from the second position to the first position (e.g., at a constant and/or variable rate).

[0072] FIGS. 4A through 4D illustrate an embodiment of a portion of a pressure exchanger including a control system **400** for the portion of the pressure exchanger. The control system **400** may include a chamber **402**, a piston **404**, one or more sensors, for example, a first sensor **406** (e.g., a sensor or a portion or element of a sensor assembly, etc.) and a second sensor **408** (e.g., a sensor or a portion or element of a sensor assembly, etc.). In some embodiments, the first sensor **406** and the second sensor **408** may be configured to detect the presence of the piston **404** through a contactless sensor (e.g., magnetic sensor, optical sensor, inductive proximity sensors, Hall Effect sensor, ultrasonic sensor, capacitive proximity sensors, etc.).

[0073] In some embodiments, the one or more sensors **406**, **408** may each include a sensor or part of a sensor on multiple components (e.g., a moving component, such as the piston **404**, and a stationary component, such as on a component positioned proximate or on the chamber **402**). In additional embodiments, the control system **400** may include only one sensor may be positioned on a movable or stationary component (e.g., at each location where a location of the piston **404** is to be determined). For example, the sensor may be positioned on the movable piston **404** or on a stationary component (e.g., proximate or on the chamber **402**) and may be capable detecting a position of the piston **404** (e.g., by sensing a property of a corresponding movable or stationary component). By way of further example, a sensor proximate or on the chamber **402** may detect the passing of the piston **404** based on a characteristic or property of the piston **404** (e.g., detecting a material of the piston **404**, sound of the piston **404**, flow characteristics of the piston **404**, a marker on the piston **404**, etc.). A reverse configuration may also be implemented.

[0074] In additional embodiments, the control system **400** may include multiple sensors or only one sensor (e.g., for each chamber **402** or piston).

[0075] In additional embodiments, the first sensor **406** and the second sensor **408** may detect the presence of the piston **404** with a sensor requiring direct contact (e.g., contact, button, switch, etc.). In some embodiments, one or more of the first sensor **406** and the second sensor **408** may be a

combination sensor including additional sensors, for example, temperature sensors, pressure sensors, strain sensors, conductivity sensors, etc.

[0076] FIG. 5 illustrates a flow diagram of the control process **500** illustrated in FIGS. 4A through 4D. In FIG. 4A, a control valve **401** (e.g., control valve **206** (FIG. 2)) may be in a first position, see act **502**. When the control valve **401** is in the first position, the piston **404** may be moving in a first direction as indicated in act **504**. The piston **404** may be moving substantially at the maximum velocity of the piston **404** as the piston approaches the second sensor **408**.

[0077] In some embodiments, maximum speed of the piston **404** may be between about 2 ft/s (0.609 m/s) and about 50 ft/s (15.24 m/s), such as between about 20 ft/s (6.096 m/s) and about 30 ft/s (9.144 m/s), or between about 25 ft/s (7.62 m/s) and about 35 ft/s (10.668 m/s).

[0078] In FIG. 4B, the control valve **401** may remain in the first position. The piston **404** may trigger the second sensor **408** (e.g., close a contact, induce a current, produce a voltage, etc.) by passing by (e.g., through, in front of, or contacting) the second sensor **408** as shown in act **506**. The presence of the piston **404** may be transmitted to the control valve **401** as shown in act **508**. In some embodiments, the trigger may be transmitted directly to the control valve **401** as a voltage, contact closure, or current as shown by line **414**. In some embodiments, the trigger may be interpreted by a controller **412** (e.g., master controller, computer, monitoring system, logging system, etc.). The controller **412** may be in parallel with the control valve **401** (e.g., the trigger is sent to both the controller and the clean control valve **206** (FIG. 2) on separate lines **414**, **415** from the second sensor **408**) or the controller **412** and the control valve **401** may be in series (e.g., the trigger may pass through the controller before reaching the control valve **401** on a common line **415**, **416** or the trigger may pass through the control valve **401** before reaching the controller on the common line). In some embodiments, the controller **412** may relay the trigger to the control valve **401** as a voltage, contact closure, or current. In some embodiments, the control valve **401** may include circuitry (e.g., control board, computer, microcontroller, etc.) capable of receiving and translating the trigger from the second sensor **408**. In some embodiments, the controller **412** may interpret the trigger and provide a separate control signal to the control valve **401** responsive the trigger.

[0079] The control valve **401** may move to the second position responsive the trigger and/or control signal as shown in act **510**. As the control valve **401** moves to the second position, the piston **404** may slow to a stop after having passed the second sensor **408** as shown in FIG. 4C and act **512**. In some embodiments, the control valve **401** may change from the first position to the second position in a time period. In some embodiments, the time period may be less than 5 seconds, less than 3 seconds, such as about 2.5 seconds, or less than 1 second, such as less than about 0.5 seconds, or less than about 0.1 seconds. During the time required for the control valve **401** to change positions, the piston **404** may slow from the maximum speed to a speed of zero and travel a distance **420** (FIG. 4B) while decelerating. The distance **420** may be between about 0.5 ft (0.1524 m) or less and about 12 ft (3.6576 m) or between about 0.1 ft (0.03048 m) or less and about 2 ft (6.096 m). The distance **420** may be determined by one or more of several factors including, for example, the processing time of the controller and/or control valve **401**, the time required for the control

valve **401** to change positions, the maximum speed of the piston **404**, a weight of the piston **404**, the compressibility of the fluid in the chamber **402**, the weight of the piston **404**, the flow rate in the chamber **402**, etc.

[0080] In some embodiments, the position of the second sensor **408** may be determined by considering the distance required for the piston **404** to decelerate to a stop such that the position of the second sensor **408** defines a distance sufficient that the piston **404** will not contact an end wall **410** of the chamber **402**. In some embodiments, the position of the second sensor **408** may be determined such that the piston **404** may contact the end wall **410** of the chamber **402** and allow mixing of the fluid from the high pressure side of the piston **404** to the fluid on the low pressure side of the piston **404**. In some embodiments, the distance required for the piston **404** to decelerate may be calculated based on estimates for one or more of the factors outlined above. In some embodiments, the distance required for the piston **404** to decelerate may be determined based on experimentation (e.g., lab experiments, data logging, trial and error, etc.). In some embodiments, the position of the second sensor **408** may be adjustable such that the position of the second sensor **408** may be adjusted in the field to account for changing conditions. For example, the second sensor **408** may be mounted to externally on the chamber **402** using a movable fitting, such as a clamped fitting (e.g., band clamp, ear clamp, spring clamp, etc.) or a slotted fitting.

[0081] In some embodiments, the trigger may control actions of other related parts of the pressure exchanger system. For example, in some embodiments, the trigger may release a check valve in the piston **404** allowing the high pressure clean fluid **210** (FIG. 2) to flush the dirty side **221a, b** (FIG. 2) of the piston **404**.

[0082] In FIG. 4D the control valve **401** may be in the second position as shown in act **514**. The piston **404** may begin to accelerate in a second direction as shown in act **516**. In some embodiments, the piston **404** may accelerate to the same maximum speed that the piston **404** was previously traveling in the first direction. The piston **404** may continue to travel at the maximum speed until the piston passes the first sensor **406**. When the piston **404** passes the first sensor **406**, the piston **404** may trigger the first sensor **406** as shown in act **518**. In some embodiments, the first sensor **406** may be the same type of sensor as the second sensor **408**. In some embodiments, the first sensor **406** may be a different type of sensors from the second sensor **408**. In some embodiments, the first sensor **406** may transmit the trigger to the control valve **401** as shown in act **520**.

[0083] In some embodiments, the trigger may be transmitted directly to the control valve **401**, as outlined above with respect to the second sensor **408**, on a line **418**. In some embodiments, the controller **412** may receive the trigger on line **417** and interpret the trigger and/or transmit the trigger and/or a control signal to the control valve **401**, as described above with respect to the second sensor **408**. Upon receipt of the control signal or trigger the control valve **401** may begin moving back to the first position as shown in act **522**. The piston **404** may again decelerate to a stop as the control valve **401** moves from the second position to the first position as shown in act **524**. Once the control valve **401** is in the first position a new cycle may begin starting at act **502**.

[0084] Now referring to FIGS. 2, 4A through 4D, and 5. In some embodiments, the clean control valve **206** may control movement of one or more pistons **404** one or more respec-

tive chambers (e.g., two chambers **202a, 202b**). In some embodiments, one chamber **202a, 202b** may be configured to be the master chamber. For example, the master chamber may include the first sensor **406** and the second sensor **408** and control the motion of the clean control valve **206**. In some embodiments, each of the chambers **202a, 202b** may include a first sensor **406** and a second sensor **408**, for example, where the sensors **406, 408** in each chamber **202a, 202b** are utilized for differing or the same functions.

[0085] In some embodiments, the status of each of the first sensors **406** and the second sensors **408** in each of the chambers **202a, 202b** may be monitored by a controller (e.g., controller **412**). The controller **412** may control the clean control valve **206**. In some embodiments, the controller **412** may be configured to interpret the signals from some of the sensors **406, 408** to make control determinations (e.g., to instruct a velocity or direction change) for the clean control valve **206** and from other sensors **406, 408** to create records (e.g., logs, models, reports, etc.) of piston **204a, 204b** locations.

[0086] In some embodiments, the controller **412** may be configured to change the position of the clean control valve **206** after both a first sensor **406** and a second sensor **408** in opposite chambers **202a, 202b** trigger. In some embodiments, the controller **412** may be configured to change the position of the clean control valve **206** as soon as any of the active first sensors **406** or second sensors **408** trigger in either of the chambers **202a, 202b**.

[0087] In some embodiments, duration of each cycle may correlate to the production of the system **100**. For example, in each cycle, the pressure exchanger **200** may move a specific amount of dirty fluid defined by the combined capacity of the chambers **202a, 202b**. In some embodiments, the pressure exchanger **200** may move between about 40 gallons (75.7 liters) and about 90 gallons (340.7 liters), such as between about 60 gallons (227.1 liters) and about 80 gallons (302.8 liters), or between about 65 gallons (246.1 liters) and about 75 gallons (283.9 liters). For example, in a system with one or more tanks (e.g., two tanks), each tank in the pressure exchanger **200** may move between about 40 gallons (75.7 liters) and about 90 gallons (340.7 liters) (e.g., two about 60 gallon (227.1 liters) tanks that move about 120 gallons (454.2 liters) per cycle).

[0088] In some embodiments, the duration of the cycles may be controlled by varying the rate of fluid flow and/or the pressure differential across the pistons **204a, 204b** with the clean control valve **206**. For example, the flow rate and/or pressure of the high pressure clean fluid **210** may be controlled such that the cycles correspond to a desired flow rate of the dirty fluid **212**. In some embodiments, the flow rate and/or the pressure may be controlled by controlling a speed of the frack pumps **102** (FIG. 1) (e.g., through a variable frequency drive (VFD), throttle control, etc.), through a mechanical pressure control (e.g., variable vanes, pressure relief system, bleed valve, etc.), or by changing the position of the clean control valve **206** to restrict flow into or out of the chambers **202a, 202b**. For example, the controller **412** may vary the control signal to the clean control valve **206** to maintain a desired pressure.

[0089] In some embodiments, maximum production may be the desired condition which may use the shortest possible duration of the cycle. In some embodiments, the shortest duration of the cycle may be defined by the speed of the actuator **303** on the clean control valve **206, 300**. In some

embodiments, the shortest duration of the cycle may be defined by the maximum pressure of the high pressure clean fluid **210**. In some embodiments, the shortest duration may be defined by the response time of the clean control valve **206, 300**.

[0090] Now referring back to FIGS. **1** and **2**. In some embodiments, the pressure exchanger **104** may be formed from multiple linear pressure exchangers **200** operating in parallel. For example the pressure exchanger **104** may be formed from at least 3 linear pressure exchangers, such as at least 5 linear pressure exchangers, or at least 7 linear pressure exchangers. In some embodiments, the pressure exchanger **104** may be modular such that the number of linear pressure exchangers **200** may be changed by adding or removing sections of linear pressure exchangers based on flow requirements. In some embodiments, an operation may include multiple systems operating in an area and the pressure exchangers **104** for each respective system **100** may be adjusted as needed by adding or removing linear pressure exchangers from other systems in the same area.

[0091] Pressure exchangers may reduce the amount of wear experienced by high pressure pumps, turbines, and valves in systems with abrasive, caustic, or acidic fluids. The reduced wear may allow the systems to operate for longer periods with less down time resulting in increased revenue or productivity for the systems. Additionally, the repair costs may be reduced as fewer parts may wear out. In operations such as fracking operations, where abrasive fluids are used at high temperatures, repairs and downtime can result in millions of dollars of losses in a single operation. Embodiments of the present disclosure may result in a reduction in wear experienced by the components of systems where abrasive, caustic, or acidic fluids are used at high temperatures. The reduction in wear will result in cost reduction and increased revenue production.

[0092] While the present disclosure has been described herein with respect to certain illustrated embodiments, those of ordinary skill in the art will recognize and appreciate that it is not so limited. Rather, many additions, deletions, and modifications to the illustrated embodiments may be made without departing from the scope of the disclosure as hereinafter claimed, including legal equivalents thereof. In addition, features from one embodiment may be combined with features of another embodiment while still being encompassed within the scope of the disclosure as contemplated by the inventors.

What is claimed is:

1. A device for exchanging pressure between fluids, the device comprising:

at least one tank comprising:

- a first side for receiving a first fluid at a higher pressure;
- and
- a second side for receiving a second fluid at a lower pressure;

at least one piston in the at least one tank, the at least one piston configured to separate the first fluid from the second fluid;

a valve device configured to selectively place the first fluid at the higher pressure in communication with the second fluid at the lower pressure through the at least one piston in order to pressurize the second fluid to a second higher pressure; and

at least one sensor configured to detect a presence of the at least one piston.

2. The device of claim **1**, wherein the at least one tank further comprises:

at least one high pressure outlet for outputting the second fluid at the second higher pressure from the at least one tank; and

at least one low pressure outlet for removing the first fluid at a second lower pressure from the at least one tank.

3. The device of claim **1**, wherein the valve device is configured to selectively output the first fluid at a second lower pressure from the at least one tank through at least one low pressure outlet.

4. The device of claim **1**, wherein the at least one sensor is configured to transmit signal related the presence of the at least one piston to a control system of the device.

5. The device of claim **1**, wherein the valve device is configured to change from a first position to a second position responsive the presence of the at least one piston detected by the at least one sensor.

6. The device of claim **1**, further comprising a controller configured to receive a signal from the at least one sensor.

7. The device of claim **6**, wherein the controller is configured to:

receive the presence of the at least one piston from the at least one sensor; and

transmit a control signal to the valve device responsive the presence of the at least one piston.

8. The device of claim **1**, wherein the at least one sensor comprises two sensors, one of the two sensors positioned at an end of the second side of the at least one tank and another one of the two sensors positioned at an end of the first side of the at least one tank.

9. The device claim **1**, wherein the at least one tank and the at least one piston comprise at least two tanks, each having a respective piston positioned therein.

10. The device of claim **9**, wherein the at least one sensor comprises at least four sensors, each of the at least two tanks including two of the at least four sensors, a first sensor being positioned at an end of the second side of a respective tank and another one of sensors positioned at an end of the first side of the respective tank.

11. The device of claim **1**, wherein the first side of the at least one tank is configured to receive the first fluid comprising a clean fluid and the second side of the at least one tank is configured to receive the second fluid comprising a dirty fluid.

12. A system for exchanging pressure between at least two fluid streams, the system comprising:

a pressure exchange device for exchanging at least one property between fluids, the pressure exchange device comprising:

at least one tank comprising:

- a first end for receiving a clean fluid with a first property; and
- a second end for receiving a dirty fluid with a second property;

at least one piston in the at least one tank, the at least one piston configured to separate the clean fluid from the dirty fluid;

a valve device configured to selectively place the clean fluid in communication with the dirty fluid through the at least one piston in order to at least partially transfer the first property of the clean fluid to the dirty fluid; and

at least one sensor configured to detect a position of the at least one piston; and

at least one pump for supplying the clean fluid to the pressure exchange device.

13. The system of claim **12**, further comprising at least two sensors configured to detect a presence of the at least one piston, wherein a first sensor is located near the first end of the at least one tank and a second sensor is located near the second end of the at least one tank.

14. The system of claim **13**, wherein the at least two sensors are configured to each transmit a signal to the valve device responsive the position of the at least one piston and the valve device is configured to change from a first position to a second position responsive the signal from the first sensor and change from the second position to the first position responsive the signal from the second sensor.

15. The system of claim **14**, wherein the first sensor is located a distance from the first end of the tank, and wherein the distance is sufficient for the at least one piston to change directions responsive to the valve device changing from the first position to the second position before reaching the first end of the tank.

16. The system of claim **14**, wherein the at least one tank and the at least one piston comprise at least two tanks, each having a respective piston positioned within a respective

tank, and wherein each of the at least two tanks is in fluid communication with the valve device.

17. A method of controlling a pressure exchange device comprising:

supplying a high pressure fluid to a high pressure inlet of a valve configured to direct flow of the high pressure fluid to a chamber;

transferring a pressure from the high pressure fluid to a dirty fluid through a piston in the chamber;

monitoring a location of the piston;

changing a position of the valve responsive the location of the piston; and

redirecting the flow of the high pressure fluid by the changing of the position the valve.

18. The method of claim **17**, wherein monitoring the location of the piston comprises sensing of a position of the piston within the chamber with at least one sensor.

19. The method of claim **17**, further comprising reversing a direction of travel of the position by redirecting the flow of the high pressure fluid.

20. The method of claim **19**, further comprising flowing the high pressure fluid into a second chamber by the changing of the position the valve.

* * * * *