

(19)



(11)

EP 3 096 147 B1

(12)

EUROPEAN PATENT SPECIFICATION

(45) Date of publication and mention of the grant of the patent:
20.12.2023 Bulletin 2023/51

(51) International Patent Classification (IPC):
G01N 35/04 (2006.01) **G01N 35/02** (2006.01)
G01N 35/10 (2006.01) **G01N 35/00** (2006.01)

(21) Application number: **16160516.7**

(52) Cooperative Patent Classification (CPC):
G01N 35/04; G01N 2035/00435;
G01N 2035/00534; G01N 2035/0455;
G01N 2035/0465

(22) Date of filing: **28.07.2010**

(54) **AUTOMATIC ANALYZER**

AUTOMATISCHER ANALYSATOR

ANALYSEUR AUTOMATIQUE

(84) Designated Contracting States:
AL AT BE BG CH CY CZ DE DK EE ES FI FR GB GR HR HU IE IS IT LI LT LU LV MC MK MT NL NO PL PT RO SE SI SK SM TR

(72) Inventors:

- **KRAEMER, Reinhold**
82380 Peissenberg (DE)
- **SAKAIRI, Susumu**
Chiyoda-ku, Tokyo 100-8220 (JP)
- **SAKASHITA, Yukinori**
Chiyoda-ku, Tokyo 100-8220 (JP)
- **SAKAZUME, Taku**
Hitachinaka-City, Ibaraki 312-0032 (JP)
- **SATTLER, Stephan**
82319 Starnberg (DE)
- **TAKAHASHI, Katsuaki**
Hitachinaka-City, Ibaraki 312-0032 (JP)
- **YAMASHITA, Yoshihiro**
Hitachinaka-City, Ibaraki 312-0011 (JP)

(30) Priority: **29.07.2009 JP 2009176005**
14.12.2009 EP 09179068

(43) Date of publication of application:
23.11.2016 Bulletin 2016/47

(62) Document number(s) of the earlier application(s) in accordance with Art. 76 EPC:
12174099.7 / 2 520 939
10737898.6 / 2 460 018

(74) Representative: **Weickmann & Weickmann**
PartmbB
Postfach 860 820
81635 München (DE)

(73) Proprietors:

- **Hitachi High-Tech Corporation**
Minato-ku
Tokyo 105-6409 (JP)
- **Roche Diagnostics GmbH**
68305 Mannheim (DE)
Designated Contracting States:
DE
- **F. Hoffmann-La Roche AG**
4070 Basel (CH)
Designated Contracting States:
AL AT BE BG CH CY CZ DK EE ES FI FR GB GR HR HU IE IS IT LI LT LU LV MC MK MT NL NO PL PT RO SE SI SK SM TR

(56) References cited:
US-A- 4 699 766 **US-A- 5 183 638**
US-A1- 2004 057 872

EP 3 096 147 B1

Note: Within nine months of the publication of the mention of the grant of the European patent in the European Patent Bulletin, any person may give notice to the European Patent Office of opposition to that patent, in accordance with the Implementing Regulations. Notice of opposition shall not be deemed to have been filed until the opposition fee has been paid. (Art. 99(1) European Patent Convention).

Description

[0001] The present invention relates generally to automatic analyzers that conduct qualitative/quantitative analyses on biological samples such as blood and urine. A first aspect not being part of the present invention concerns an automatic analyzer including a reagent container holding unit that holds reagent containers each containing a reagent to be used for analysis, and a reagent container supply unit that supplies reagent containers to the reagent container holding unit.

[0002] Automatic analyzers that analyze blood and other biological samples automatically and output the results are among the apparatuses absolutely necessary to perform efficient analyses at the testing centers and other medical laboratory facilities that subcontract to test/examine samples on behalf of hospitals and clinics that have many patients. It is being desired that these automatic analyzers be more compact, capable of conducting more kinds of analyses, and have higher throughput.

[0003] If the reagent set up in the apparatus runs short during analysis, stopping the analysis before taking any necessary steps will reduce the efficiency of the analysis. Automatic analyzers are therefore designed so that if a shortage of reagent is likely, the apparatus will warn the operator about the shortage, thus avoiding the situation that the operator will have to stop the apparatus to replace the reagent with a new one of the same kind during the analysis.

[0004] JP 4033060 describes a more advanced technique for preventing a shortage of reagent from occurring during analysis. In the technique of JP 4033060, a first and a second reagent-container storage means are provided beforehand and if the reagent stored within the first reagent-container storage means runs short, a reagent container as a replacement is supplied from the second reagent-container storage means automatically.

[0005] According to the technique described in JP 4033060, although a plurality of reagent containers can be stored in the second reagent-container storage means, one reagent container can only be conveyed at a time from the second reagent-container storage means to the first reagent-container storage means. In addition, holding a plurality of reagent containers in the second reagent-container storage means for an extended time requires providing cold-storage means, the provision of which could result in an oversized apparatus structure.

[0006] As to the first aspect not being part of the invention it is an object to provide an automatic analyzer that enables automatic replacement of a reagent during analysis and eliminates a need of providing such reagent cold-storage means as described in Patent JP 4033060.

[0007] More particularly, the present invention relates to an analyzer with the features of the preamble part of claim 1, the analyzer comprising an apparatus for providing reagents to be used in analyses to be performed by the analyzer,

wherein said apparatus for providing reagents comprises

- a turntable having an axis of rotation and being adapted for storing thereon a plurality of reagent container assemblies in an arrangement of at least one arcuate row,
- at least one treatment zone for treating reagent container assemblies stored on said turntable, and
- treatment means for treating reagent container assemblies positioned in said treatment zone,

wherein said turntable comprises compartments arranged to accommodate the reagent container assemblies at predetermined locations on the turntable so as to form said arrangement of at least one arcuate row of reagent container assemblies corresponding to the arrangement of said compartments, and wherein said turntable is adjustable by rotation so as to selectively move compartments in predetermined positions for disposing reagent container assemblies in predetermined positions in said treatment zone.

[0008] Analyzers of the above mentioned kind are known in various embodiments e. g. from EP 0 703 457 B1, EP 1 275 966 B1, US 7 547 414 B2 and US 7 384 601 B2.

[0009] Those analyzers are used for automatically analyzing samples in order to determine the existence and particularly the concentration of specific components in the samples. Such analyzers are widely used in hospitals and clinical laboratories to analyze biological samples, namely body fluids collected from patients, such as blood and urine, in order to diagnose their morbidities.

[0010] A method for analyzing such a biological fluid sample by means of an analyzer of the above mentioned type is explained e. g. in EP 1 051 621 B1. The workflow of an analyzer of the above mentioned kind is usually completely sample orientated, i. e. analytical determinations are performed serially in a respective fluid sample, wherein for each analytical determination a set of different reagents is used to be added to a separated part of said sample. It is therefore required to provide a lot of different reagents on the turntable of the apparatus for providing reagents, and it is required that a fast access to particular reagent container assemblies on the turntable by treatment means such as pipetting means or agitating means is possible in order to achieve a high throughput of the analyzer. It is generally required that such an analyzer apparatus and particularly the apparatus for providing reagents has small dimensions to be space-saving.

[0011] An analyzer with the features of the preamble part of claim 1 is known from US 2004/0057872 A1. Furthermore, document US 4,699,766 A discloses an analyzer configured to prepare and analyze a sample in a

reaction tube on a turntable comprising an inner and an outer turntable partition. The reaction tube is transported first in a clockwise direction on the outer turntable partition, radially shifted to the inner turntable partition and then transported in an anticlockwise direction on the inner turntable partition in order to transfer the reaction tube between an arrangement of different treatment stations. On the outer turntable partition, a sample, a diluent and a first reagent are added to the reaction tube via corresponding nozzles fixedly arranged above the turntable, and then the content of the tube is stirred in a first stirring station. After the tube has been transferred to the inner turntable partition, a second reagent is added and the content of the tube is stirred again before an optical analysis is performed on the sample in the reaction tube.

[0012] It is an object of the present invention to provide an analyzer of the above mentioned type with an apparatus for providing reagents that may be operated in a more efficient way in comparison with analyzers of the prior art.

[0013] An automatic analyzer according to the first aspect not being part of the present invention is configured as follows:

The analyzer includes: a reagent container transport unit adapted for mounting a plurality of reagent containers thereon, and constructed to transport the reagent containers to desired positions; a reagent container mounting unit adjacent to the reagent container transport unit and having an ability to supply the reagent containers to the reagent container transport unit; and a reagent container moving unit that moves the reagent containers from the reagent container mounting unit to the reagent container transport unit.

[0014] A more preferred aspect is outlined below.

[0015] Only a reagent driving disk that moves to positions for reagent dispensing and stirring, reagent container lid opening/closing, and the like, is provided as a disk in the automatic analyzer according to an aspect of the present invention. In an automatic analyzer according to a more preferred aspect of the present invention, however, a fixed disk without a drive such as a motor is added at a location adjacent to such a reagent driving disk. The automatic analyzer according to the more preferred aspect also includes a magnetic particles stirring unit at a position adjacent to the fixed disk. This layout of the fixed disk and the magnetic particles stirring unit enables a temporarily idle reagent container on the fixed disk to be made to stand by thereon. Thus, the reagent driving disk is of compact construction. Additionally, positioning the magnetic particles stirring unit adjacently to the fixed disk renders magnetic particles stirring executable on the fixed disk, ensures a sufficient stirring time, and enables uniform stirring without causing unfavorable events such as bubbling. Furthermore, a reagent can be dispensed into a reagent container on the fixed disk as well as on the driving disk, so that magnetic particles in a reagent in one reagent container can be stirred on the fixed disk while a reagent in other reagent container can be dis-

pensed on the fixed disk.

[0016] A reagent container moving unit adapted to move reagent containers between the reagent driving disk and the fixed disk is further provided, whereby the reagent containers can be moved between the reagent driving disk and the fixed disk according to a particular analytical situation.

[0017] Moreover, providing a loading system in a part of the reagent stand-by disk enables reagent container replacement, even during reagent transport disk operation. The reagent can therefore be replaced without reducing throughput. Since a cooling function for the loading system is further added and since the cooling function is provided in a part of the reagent disk, the loading system can be provided without adding a space in any other section of the apparatus. As a result, the reagent disk alone can be miniaturized and the apparatus correspondingly downsized.

[0018] The following advantageous effects may be indicated:

(1) A large number of reagent containers including the one standing by can be set in the apparatus.

(2) The number of reagent containers changes can be reduced.

(3) The reagent disk can be miniaturized.

(4) The reagent containers can be replaced without reducing throughput.

[0019] The object of the present invention is solved by an analyzer with the features of claim 1. According to the invention, the turntable comprises

- a first circular turntable partition centered around the axis of rotation and carrying said arcuate row of compartments, and
- a second turntable partition arranged radially adjacent to said first turntable partition and carrying a first compartment for accommodating a reagent container assembly therein,

wherein said first turntable partition is rotatable relative to the second, fixed turntable partition about said axis of rotation so as to selectively adjust a compartment of said first turntable partition in radial alignment with said first compartment of the second turntable partition in a mutual transfer position in which a reagent container assembly is radially shiftable between said aligned compartments in said treatment zone.

[0020] The analyzer according to the present invention allows to pursue a specific strategy in supplying the reagents required for performing the analytical determinations according to specific assay protocols.

[0021] The steps of extracting different reagents from reagent container assemblies may take different times,

depending on the particular reagents and special preparation measures to be taken before particular reagents can be withdrawn from reagent container assemblies by way of pipetting. Such a preliminary preparation step is a mixing or agitating step which is necessary to homogenize reagents which tend to sediment. One example for such a reagent is a suspension of beads. Such a suspension of beads is typically used in almost each analytical determination process to be performed with an analyzer according to the present invention. The beads tend to deposit on the bottom of the container section which includes the bead suspension. If beads of such a sedimented suspension are required for a present analytical determination process it is necessary to homogenize the suspension by way of agitation with a stirrer or the like which is to be dipped into the reagent container section. Such an agitating or mixing step is comparatively time-consuming.

[0022] According to the present invention such a time-consuming mixing step may be performed with the particular reagent to be mixed being provided in a reagent container assembly that is temporarily stored in the first compartment of the second turntable partition during the mixing step. In the meantime the first turntable partition may be operated to provide other reagent container assemblies in the treatment zone in order to be treated on a faster time scale, e. g. by extracting reagents therefrom by means of pipetting units. In other words, in the part of the treatment zone which is supplied with reagent container assemblies by the first turntable partition, treatment steps may be performed independently and parallel to a treatment step performed in the part of the treatment zone which is assigned to the second turntable partition.

[0023] After the termination of a time-consuming treatment step performed on a reagent container assembly provided on the second turntable partition, that reagent container assembly may be transferred to the first turntable partition.

[0024] Thereafter, a further reagent container assembly may be transferred from the first turntable partition to the second turntable partition when the respective compartments have been radially aligned in their mutual transfer position.

[0025] The operation of the turntable and the treatment means is controlled by a controller in a time-optimized manner.

[0026] Preferably, the first circular turntable partition is arranged radially outward of the second circular turntable partition with regard to the axis of rotation. Such an arrangement can be realized in a space-saving manner with a relatively great capacity of the first turntable partition for storing a great number of reagent container assemblies.

[0027] The reagent container assemblies to be used in the analyzer according to the present invention are preferably multisection containers with at least two, preferably three container sections, each of which has an inner volume containing a particular reagent. The con-

tainer sections are arranged side-by-side in a row and are connected to form a unitary cassette type assembly which has upper openings for gaining access to the inner volumes of the container sections by a stirrer, a pipetting unit or the like. Each opening is normally closed and covered by a respective cap which can be reversibly moved from its closing cover position to an opening position. Usually a cap will be in the opening position only for short times during momentary phases of access to the inner volume of the respective container section. Thereafter the cap should be moved back in the closing position in order to avoid evaporation and/or contamination of the reagent in the container section.

[0028] The analyzer according to the present invention preferably comprises a cap manipulating mechanism for selectively displacing caps of reagent container sections into their opening position and closing position respectively. The cap manipulating mechanism is a part of the treating means of the analyzer.

[0029] In order to enable an automatic shifting of a reagent container assembly between the first turntable partition and the second turntable partition the analyzer of the present invention preferably comprises a container shift mechanism for shifting reagent container assemblies between radially aligned compartments of said turntable partitions in their mutual transfer positions, wherein said container shift mechanism comprises radially movable engagement means for engaging and shifting a reagent container assembly between compartments in their mutual transfer position. Such a shifting of a reagent container assembly is enabled only in the case that one of the aligned compartments is vacant.

[0030] According to a preferred embodiment of the invention the second turntable partition carries a plurality of compartments including said first compartment for accommodating reagent container assemblies in an arrangement of an arcuate row radially adjacent said arcuate row of compartments of the first turntable partition, wherein at least two of the compartments, preferably all compartments of said second turntable partition are radially alignable with respective compartments of the first turntable partition in mutual transfer positions. With regard to the last mentioned embodiment of the invention it is preferred that said container shift mechanism is movable around the axis of rotation in selected angular positions corresponding to angular positions of the radial alignment of compartments aligned in their mutual transfer positions. In this manner it is possible to exchange reagent container assemblies between various compartments of the turntable partitions. The compartments of the second turntable partitions may be used to store backup reagent container assemblies containing reagents which are used in larger amounts than other reagents for analytical determinations to be performed according to predetermined assay protocols. Such a backup reagent container assembly may be transferred from the second turntable partition to the first turntable partition in exchange with an at least partially empty reagent

container assembly. In order to enable such transfers of reagent container assemblies between the turntable partitions it is necessary that at least one compartment is vacant for accommodating a reagent container assembly. The analyzer according to the present invention comprises as treatment means pipetting means which are movable for access to at least one of reagent container assemblies positioned in said predetermined positions in said treatment zone. The pipetting means should be movable for access to reagent container assemblies positioned on the first turntable section and provided in said treatment zone. According to a further embodiment of the invention the pipetting means are also movable for access to a reagent container assembly positioned on the second turntable partition and provided in said treatment zone.

[0031] Preferably one of the compartments of the first turntable partition and at least one of the compartments of the second turntable partition are radially aligned to dispose reagent container assemblies contained therein on a straight radial line when positioned relative to each other in said predetermined positions in the treatment zone, wherein said apparatus for providing reagents comprises a driving and guiding means for selectively moving said pipetting means to reagent container assemblies positioned relative to each other in said predetermined positions in the treatment zone.

[0032] According to a further preferred embodiment of the invention said pipetting means comprise at least two pipetting units wherein said driving and guiding means are adapted to selectively move each pipetting unit according to a specific treatment program. The pipetting units may be guided for common movement along a linear guidance which is oriented in the radial direction of the turntable. Each pipetting unit has a pipette tip or intake tube and the distance between the pipette tips of the common horizontally movable pipette units correspond to the distance between the centers of openings of adjacent reagent container sections of a reagent container assembly so that both pipette tips may be simultaneously moved into adjacent openings of a reagent container assembly positioned in the treatment zone. For the up-and-down movement of the pipette tips vertical drive means are provided which are preferably controllable to drive the pipetting tips independently from each other.

[0033] As mentioned above, the treatment means comprise agitating means including a stirrer adapted to access a reagent container assembly accommodated in the first compartment of the second turntable partition.

[0034] In case that the container shift mechanism is adapted to be operated in different angular positions beside or outside of the treatment zone section, in which the pipetting means operates, it is preferred that the container shift mechanism and the pipetting means and the agitating means are selectively operable in order to simultaneously treat separate reagent container assemblies with the container shift mechanism, the pipetting means and the agitating means, respectively.

[0035] The agitating means and the pipetting means are simultaneously operable in order to simultaneously treat separate reagent container assemblies, or in special cases the same reagent container assembly, with the agitating means and the pipetting means.

[0036] According to the invention the second turntable partition is fixed with regard to the axis of rotation, whereas the first turntable partition is rotatable around the second turntable partition.

[0037] According to a further preferred embodiment of the invention the turntable has a radial inner center including the axis of rotation, wherein a cleaning station for cleaning treatment means and a drain channel for draining cleaning fluid is arranged in the area of said radial inner center. Such a construction may be realized by means of a hollow shaft of the turntable and at least one cleaning fluid source, particularly a nozzle providing cleaning fluid to be drained off in the drain channel. Since a stirrer of the agitating means usually must be cleaned after each mixing operation it is preferred that said agitating means is movable between a working position to agitate fluid in a reagent container assembly positioned in a compartment of the second turntable partition, particularly in the first compartment thereof, and a cleaning position to be cleaned by said cleaning means of said cleaning station.

[0038] Hereinafter, preferred embodiments of the present invention will be explained with reference to the drawings, wherein figures 1 - 6 are primarily used to illustrate the first aspect not being part of the invention whereas figures 7-15 are primarily used to illustrate the invention.

Fig. 1 is a total apparatus configuration diagram of an automatic analyzer of the present invention, the analyzer including a reagent disk which is hereinafter also called turntable;

fig. 2 is a perspective view of the reagent disk;

fig. 3-1 is a perspective view of the reagent disk, showing the disk particularly with a lid removed;

fig. 3-2 is a top view of the reagent disk, showing the disk particularly with the lid removed;

fig. 3-3 is a perspective view of the reagent disk, showing the disk particularly under the state thereof in fig. 3-2;

fig. 4 is a schematic view of a loading system;

fig. 5 is a schematic view of a reagent container moving unit;

fig. 5-1 is a schematic view showing a part of the reagent container moving unit; and

fig. 6 is a flow diagram of reagent container moving operations;

figure 7 is a top plan view of an embodiment of a turntable of an analyzer according to the second aspect of the present invention;

figure 8 is a top plan view of an apparatus for providing reagents according to the present invention including the turntable of figure 7;

figure 9a and figure 9b are perspective views of a reagent container assembly in the closed state and in the opened state;

figure 10 is a side view of treatment means of the apparatus of figure 8;

figure 11 is a perspective view of the treatment zone of the apparatus of figure 8;

figure 12 is a perspective view of a detail of the treatment zone;

figure 13 is a perspective view of a detail of the turntable and the container shift mechanism;

figure 14 is a perspective view of the container shift mechanism;

figure 15 is a perspective view of an alternative embodiment of a compartment dividing wall.

[0039] Embodiments of the present invention are described in detail below using the accompanying drawings. Fig. 1 is an exemplary configuration diagram of an automatic analyzer of the present invention, the analyzer including a reagent disk (also called turntable).

[0040] A samples transport line 114 in the automatic analyzer 101 transports samples 104 to sample dispensing pipettes neighboring a sample dispensing unit 115.

[0041] A sample dispensing tip/reaction vessel transport unit 106 is adapted to move above a reaction vessel disposal hole 102, a sample dispensing tip buffer 103, a reaction solution stirring unit 105, a sample dispensing tip/reaction vessel station 107, and part of an incubator disk 108, in directions of X-, Y-, and Z-axes. The sample dispensing tip/reaction vessel transport unit 106 moves reaction vessels from the sample dispensing tip/reaction vessel station 107 to the incubator disk 108. The sample dispensing tip/reaction vessel transport unit 106 also moves sample dispensing tips to the sample dispensing tip buffer 103. The sample dispensing unit 115 moves to an upper area of the sample dispensing tip buffer 103 having sample dispensing tips placed in the buffer, and picks up any one of the sample dispensing tips. Next after moving to an upper area of a sample and acquiring the sample by suction, the sample dispensing unit 115 further

moves to an upper area of a reaction vessel on the incubator disk 108, and discharges the sample into the reaction vessel. After this, the sample dispensing unit 115 moves to an upper area of the sample dispensing tip/reaction vessel disposal hole and dumps the sample dispensing tip thereinto for disposal.

[0042] The incubator disk 108 has an ability to retain a plurality of reaction vessels, and moves each of the reaction vessels to a predetermined position on a circumference of the disk 108 by rotary motion.

[0043] The reagent disk 111 is adapted to retain a plurality of reagent containers 110, and moves each reagent containers 110 to a predetermined position on a circumference of the disk 111 by rotary motion. The reagent container 110 itself comprises multiple reagent included in a magnetic particles solution.

[0044] A reagent dispensing pipettor 109 moves to an upper area of a predetermined kind of reagent on the reagent disk 111, then suctions a predetermined amount of reagent, and after moving to an upper area of a predetermined reaction vessel on the incubator disk, discharges the reagent into the reaction vessel.

[0045] A magnetic particles stirring arm 116 (also called stirrer) as an agitating means is set on the reagent disk 111. The arm 116 moves to an upper area of the reagent container containing the reagent inclusive of the magnetic particles solution to be stirred, and stirs the magnetic particles solution by lowering a magnetic particles stirring element of the arm 116 and rotating the stirring element. In order to release the magnetic particles from a natural settling state in the solution, the magnetic particles stirring arm 116 stirs the magnetic particles immediately before the reagent is dispensed. After the stirring, the magnetic particles stirring arm 116 moves to an upper area of a cleaning cell containing a cleaning liquid, and then lowers and rotates the magnetic particles stirring element to remove sticking magnetic particles therefrom.

[0046] A reaction solution suction nozzle 112 suctions from the reaction vessel a reaction solution formed after an elapse of a predetermined reaction time from dispensing of a sample and the predetermined reagent, and then supplies the reaction solution to a detection unit 113. The detection unit 113 analyzes the reaction solution. The sample dispensing tip/reaction vessel transport unit 106 moves the analyzed reaction solution to the upper area of the sample dispensing tip/reaction vessel disposal hole and dumps the sample dispensing tip thereinto for disposal.

[0047] These actions of the apparatus are controlled by a host computer as a control means not shown.

[0048] The apparatus combines and repeats the above actions to efficiently analyze a plurality of samples over a plurality of analytical items.

[0049] Fig. 2 is an external view of the reagent disk 111 according to the present invention. In order to control the reagent container 110 to a constant temperature, the reagent disk 111 includes a lid 201 having a heat-insu-

lating function, and a jacket 202.

[0050] Fig. 3-1 is an external view of the reagent disk 111, showing the disk particularly with the lid 201 removed. The reagent disk 111 includes: a reagent driving disk 301 (also called first turntable partition) for transporting the reagent 110 to a desired position; a reagent driving disk driving unit 302 that drives the reagent driving disk 301; a fixed disk 303 (also called second turntable partition) adapted to make temporarily stand by thereon a reagent container that contains the reagent container 110 of the same kind; a loading system 304 that permits reagent containers 110 to be mounted in the system, even during analysis; a reagent container moving unit 305 (also called container shift mechanism) for moving the reagent container 110 from the reagent driving disk 301 to the fixed disk 303 or the loading system 304; a reagent information reading device 306 for reading information on the reagent, such as an analysis time and analytical items; and a partition plate 307 for partitioning a space between reagent containers 110.

[0051] Fig. 3-2 is a top view of the reagent disk shown in fig. 3-1. The fixed disk 303 has a reagent stand-by position 308 and a reagent stirring position 309. In addition, a reagent dispensing position 310 is present on an operational path of the reagent driving disk 301. The reagent stirring position 309 is adjacent to the reagent dispensing position 310, and present on an operational path of the reagent dispensing pipettor. This region of the reagent disk is also called treatment zone.

[0052] Fig. 3-3 is a perspective view of the reagent disk shown in fig. 3-2. While the magnetic particles stirring arm 116 is stirring the internal magnetic particles solution of the reagent container at the reagent stirring position 309, the reagent dispensing pipettor 109 can dispense the same kind of reagent into other reaction vessels. This ensures a sufficient magnetic-particles stirring time and enables simultaneous execution of dispensing and stirring. The same item can therefore be analyzed without reducing throughput. In fig. 3-3, the reagent dispensing position 310 and the reagent stirring position 309 are lined up rectilinearly and both exist on the same position as the operational path of the reagent dispensing pipettor. Substantially the same also applies, even if the operational path of the reagent dispensing pipettor lies on a circumference.

[0053] A process flow of reagent container movement during reagent stirring is described below.

[0054] A position of a reagent container containing the reagent to be stirred is detected by the host computer. If this reagent container is present on the reagent driving disk, this disk moves to a position adjacent to the reagent stirring position, within an operational cycle time. Next, the reagent container moving unit moves the reagent container to the reagent stirring position within the fixed disk. Stirring by the magnetic particles stirring arm then follows.

[0055] If the reagent container is present in the reagent stand-by position, the reagent driving disk is checked for

vacant positions. If a vacancy is present on the reagent driving disk, the reagent driving disk moves to a position adjacent to the reagent stand-by position in which the reagent container is present. Next, the reagent container moving unit moves the reagent container to the reagent driving disk and then as described above, further moves the reagent container to the reagent stirring position. Conversely if a vacancy is absent on the reagent driving disk, the host computer checks all reagent containers set on the reagent driving disk and searches for a reagent container temporarily movable to the reagent stand-by position. For example, the search is conducted using a parameter such as searching in ascending order of frequency of analytical request or in ascending order of frequency of measurement request. The reagent container, after being detected, is moved to the reagent stand-by position, and then the reagent container to be subjected to reagent stirring is moved to the reagent driving disk first and then to the reagent stirring position.

[0056] Fig. 4 is a schematic view of the loading system 205. The loading system forms part of the fixed disk located at an inner circumferential section of the reagent disk, and the system operates in upward and downward directions. For example, if the fixed disk exists at an outer circumferential section of the reagent disk, the loading system may be constructed so that the system can be pulled out in perpendicular or lateral directions. In addition, since a part of the fixed disk is the loading system and since the system has a shape that enables five reagent containers to be changed, two or more reagent containers would be replaceable or one reagent container would only be replaceable. The loading system 205 includes a reagent placing unit 401 in which to place reagent containers 110, a reagent actuator 402 adapted for upward/downward reagent actuation, indicators 403 each indicating whether the reagent is replaceable, a loading system locking unit 404 for locking the loading system, and an indicator lamp 405 notifying that the locking unit has unlocked the loading system. Among other methods useable to supply information on whether the loading system has been unlocked to enable reagent replacement would be one by providing a mechanism that slides the system upward to come out to the surface immediately after unlocking. Furthermore, although the loading system is constructed to be manually openable using a grip provided at the actuator, the system would be automatically movable to a reagent replacement position by, for example, adding a driving unit to the actuator itself.

[0057] An example of a reagent-adding sequence by an operator is described below.

[0058] A flow of successive reagent-loading operations is described first. The operator selects a reagent add/replace request via the host computer. The host computer analyzes a current operational status of the apparatus, then if reagent replacement is judged to be executable, activates the locking unit to unlock the loading system, and lights up the indicator lamp to notify that

the reagent replacement can be conducted. Pursuant to the information from both the host computer and the indicator lamp, the operator judges that the reagent is replaceable. After confirming that the reagent replacement is executable, the operator opens the loading system, then loads a replacement reagent container into a vacant position, and closes the loading system. After the closing of the loading system following completion of replacement reagent container mounting, the operator checks a sensor or the like and makes sure that the loading system is properly closed.

[0059] Next, a flow of successive reagent-replacing operations is described below. The operator selects a reagent add/replace request via the host computer, as in the reagent-adding sequence. The host computer then analyzes the current apparatus status. After judging reagent replacement to be executable, the host computer unlocks the loading system by the locking unit to enable the replacement. Since the loading system is also used as the fixed disk, all reagent containers may have already been mounted in the system when the replacement is conducted. In such a case, the indicator indicates whether the reagent container is replaceable. For example, if the indicator has a red and a green light source and the red one is on, the corresponding reagent container is unusable as a replacement, and if the green light source is on, the reagent container is usable as a replacement. Alternatively, if the reagent container cannot be used as a replacement, providing the locking unit properly will prevent the particular reagent container from being pulled out for removal. After replacing the reagent container, the operator closes the loading system properly and then confirms through the host computer that the loading system has been properly closed. The confirmation completes the replacement sequence.

[0060] Fig. 5 is a schematic view of the reagent containers moving unit 305 (also called container shift mechanism). The reagent container moving unit 305 includes an arm mechanism 501 that moves a reagent container 110, and a drive portion 502 that rotates the arm mechanism 501. Fig. 5-1 is a schematic view of the arm mechanism 501. The arm mechanism 501 includes an arm 503 used for moving the reagent container 110, a lateral arm drive portion 504 that moves the arm forward and backward, and a rotational arm drive portion 505 that rotates the arm. The reagent container moving unit 206 moves reagent containers between the loading system and the reagent driving disk, as well as between the reagent driving disk and the fixed disk. A reagent container moving sequence is described below using an example of a movement between the reagent driving disk and the fixed disk. First, the reagent driving disk moves a desired reagent container to a position in the same radial direction as that of the fixed disk onto which the reagent container is to be stored. After the movement, the arm mechanism rotates to a position to which the reagent container can be moved. Next, the lateral arm drive and the rotational arm drive operate for the arm to grip the reagent contain-

er, and then the lateral arm drive operates to make the arm move the gripped reagent container from the reagent driving disk to the fixed disk. Finally, the lateral arm drive and the rotational arm drive cause the arm to release the container from the gripped position. This completes the moving sequence. When the arm grips the reagent container, an actuator such as a motor may actuate the arm to hold the container from both sides, for example. In addition, when the reagent container moving unit moves the reagent container, the arm may be driven by the actuator to grip the container or pressed against the container, to conduct the movement.

[0061] Fig. 6 is a flow chart that shows the flow of analytical reagent container movement on the reagent disk of the present invention. When analysis is requested from the operator in step 601, whether a reagent container to be used for the analysis exists on the reagent driving disk is next confirmed in step 602. If the reagent container to be used for the analysis is already set on the reagent driving disk, a process for no reagent container movement is executed in step 603 and the analysis is immediately executed in step 609. If the reagent container to be used for the analysis is not set on the reagent driving disk, any reagent container containing the same kind of reagent as used for the analysis is moved from the fixed disk to the reagent driving disk. Prior to this movement, it is confirmed in step 604 whether a vacant position is present on the reagent driving disk. If a vacant position is present, the reagent container moving unit moves any reagent container containing the same kind of reagent, from the fixed disk to the reagent driving disk, in step 605. If a vacant position is absent, whether a vacant position exists on the fixed disk is confirmed in step 606. If a vacant position on the fixed disk exists, a reagent container movable to the reagent fixed position is moved from the reagent driving disk to the reagent fixed position in the moving process step 607. If a vacancy is absent, the reagent container moving unit moves any reagent container containing the same kind of reagent, from the reagent driving disk to the loading system, in step 608. After this movement, the same kind of reagent container required for the analysis is moved from the fixed disk to the reagent driving disk in step 605 by the reagent container moving unit, and then in step 609, an executable state of the analysis is registered in the host computer.

[0062] An installation flow of the reagent disk can be divided into two major sequences: (1) a sequence from completion of reagent container loading to a start of the analysis, and (2) a sequence for reagent replacement due to a shortage or expiration of the reagent.

(1) Sequence from completion of reagent container loading to a start of the analysis. An example of a sequence from completion of reagent container loading to a start of the analysis is described below. After a reagent container containing the required kind of reagent has been loaded from the loading system, the host computer upon confirming that the

loading system has been closed properly by the operator activates the locking unit to lock the system, and reads reagent information from the mounted reagent container using a reagent information reading device equipped in or on the disk. The reagent container has an identifier affixed thereto. Measurement items and other information are prewritten on the identifier. The identifier is, for example, a bar code, a radio-frequency identification (RFID) tag, or the like. The reagent information, when read properly, will be registered and the reagent container moved to the reagent driving disk by the reagent container moving unit. The host computer will recognize a position on the reagent driving disk where the moved reagent container was loaded, and register the information. The movement will be followed by a process required for the analysis, such as calibration. The reagent container upon completion of this process will be usable, and the host computer will register the reagent as one that can be used for the analysis.

(2) Sequence for reagent replacement due to a shortage or expiration of the reagent. An example of this sequence is described below. The host computer measures the amount of reagent in the reagent container. The reagent information that has been registered in the loading system contains an expiration date of the reagent, and the host computer judges from this date whether the reagent maintains its chemical effectiveness. If the reagent has already expired or is insufficient in quantity, the host computer will deliver an alarm to the operator, notifying that the reagent requires replacement. At the same time, the reagent container moving unit will move the reagent container from the reagent driving disk to the loading system. At this time, the host computer will confirm the reagent container information registered in the loading system. If the loading system is now capable of accepting a plurality of reagent containers and has at least one vacant loading position, the particular reagent container will be moved to one of the vacancies. If the loading system has no vacancy, the reagent container will be moved to the fixed disk and made to stand by thereon until a vacant loading position has been created. After the reagent container has stood by, when the vacancy occurs in the loading system, the reagent driving disk and the reagent container moving unit will operate to move a replacement reagent container to the loading position. After the movement of the replacement reagent container, the host computer will notify to the operator that the reagent container has become ready for the replacement.

[0063] With regard to figures 7 - 15 a further embodiment of the invention is described below.

[0064] The turntable shown in figure 7 has a circular construction with a radially outer ring-shaped first parti-

tion 3 and a radially inner circular or ring-shaped second partition 5. The first turntable partition 3 is movable about a vertical central axis of rotation 7 relative to the second turntable partition 5. The first turntable partition 3 and the second turntable partition 5 of the embodiment according to figures 7-15 correspond essentially to the reagent driving disk 301 and the fixed disk 303, respectively of the first embodiment according to figures 1 - 6.

[0065] The first turntable partition 3 is equipped with a plurality of compartments 9, namely forty-eight compartments in the present embodiment. The compartments 9 are separated by dividing walls 56. Each compartment 9 is adapted to accommodate a reagent container assembly 11 in a fitted position.

[0066] Each reagent container assembly 11 consists of three containers or container sections 13a, 13b, 13c as shown in figures 9a and 9b. The containers 13a, 13b, 13c are made of plastic material and are interconnected and fixed to each other at welding spots 15 so that they form a reagent container assembly 11 with three container sections 13a, 13b, 13c in an in-line configuration. Each container section 13a, 13b, 13c contains a particular reagent to be used in particular analytical determinations to be performed by means of the analyzer comprising the turntable 1. In the present embodiment the outer container section 13a in figures 9a and 9b contains a suspension of microparticles ("beads") which are used in the analytical determinations as micro carriers for complex molecules which are characteristic for the analysis.

[0067] The other container sections 13b and 13c contain other specific reagents to be used in analysis steps according to a specific assay protocol.

[0068] Each container section has an upper opening 17 which is normally closed by means of a cap 19 as shown in figure 9a. Each cap 19 is pivotable mounted to the housing of its container section 13a, 13b, 13c so that it is pivotable about the hinge 21 between a closing position according to figure 9a and the opening position according to figure 9b. Normally, the container sections 13a, 13b, 13c are closed by said caps 19 being in the closing position, in order to avoid evaporation of the reagents contained therein.

[0069] The container sections 13a - 13c have to be opened according to figure 9b if access to the inner volume thereof is required. An automatic cap manipulating mechanism (not shown) is adapted to selectively open or close the container sections 13a - 13c by moving the caps 19 in the respective closing or opening positions. Said cap manipulating mechanism is provided in a treatment zone 23 for treating a reagent container assembly 11 stored on said turntable 1 in respective compartments 9 and 25. The compartments 9 are arranged side-by-side to form an arcuate or ring-shaped row of compartments 9 on the first turntable partition 3. The second turntable partition 5 has a first compartment 25 which is radially aligned in the treatment zone 23. The compartments 25, 27 of the second turntable partition 5 are open at their radially outer ends, whereas the compartments 9 of the

first turntable partition 3 are open at their radially inner ends. Since the second turntable partition 5 is fixed with regard to the axis of rotation 7, the first compartment 25 remains in the treatment zone 23. Since the first turntable partition 3 is rotatable around the second partition 5 each compartment 9 of the second turntable partition 3 can be selectively moved into the treatment zone 23 in radial alignment with the first compartment 25 of the second turntable partition 5 in a mutual transfer position as it is shown in the snap shot of figure 7 for the compartment 9a of the first turntable partition 3. In said mutual transfer position the container assembly 11 which occupies the first compartment 25 can be shifted radially outward into the compartment 9a of the first turntable partition. Thereafter said reagent container assembly 11 can be removed from the treatment zone 23 by rotation of the first turntable partition 3. The first compartment 25 of the second turntable partition 5 is then vacant and may be loaded with another reagent container assembly 11 from the first turntable partition 3 after having positioned that reagent container assembly 11 in radial alignment with the first compartment 25.

[0070] Beside the first compartment 25 are arranged some further compartments 27 on the second turntable partition 5 to form a circular arc shaped row of radially oriented compartments 25, 27. Each compartment 27 may be used to exchange a reagent container assembly 11 between the first turntable partition 3 and the second turntable partition 5 in the manner as described above with regard to the first compartment 25.

[0071] The radial shifting of reagent container assemblies 11 between the turntable partitions 3, 5 is performed automatically by means of a container shift mechanism 29.

[0072] Figure 8 shows the turntable 1 in the same top plan view as figure 7, but with further components of the apparatus for providing reagents, namely treating means 31 for treating reagent container assemblies 11 positioned in said treatment zone 23.

[0073] The further treatment means 37 are also shown in a side view in figure 10. They comprise a frame 33 in the shape of a gallows with a vertical pile 34 fixed radially outward of the turntable 1 and a cantilever 35 extending horizontally from said pile 33 above the turntable 1 so as to dispose treatment units 37, 39, 41 for acting in said treatment zone 23. The treatment unit 37 is a stirrer which is a part of an agitating means 38 that is guided for horizontal movement on a linear guidance 43 which is attached to the cantilever 35. The units 39, 41 are pipetting tubes of a pipetting means 40 which is also guided for horizontal movement on said linear guidance 43. The agitating means 38 and the pipetting means 40 are movable independently from each other along the guidance 43 by driving means which are controlled by a control means (not shown).

[0074] The agitating means 38 has a vertical driving means 45 for selectively lowering or raising the stirrer 37, and a driver 44 for rotating the stirrer 37.

[0075] The pipetting means 40 comprises vertical driving means 47, 49 for each pipette unit 39, 41. Said vertical driving means 47, 49 of the pipetting units 39, 41 are controllable by the control means in order to independently raise or lower the pipetting units 39, 41.

[0076] In figure 8 the agitating means 38 are adjusted on the horizontal guidance 43 and in stand-by position in which the stirrer 37 is in vertical alignment with the radially innermost disposed container section 13a of a reagent container assembly 11 accommodated in the first compartment 25 (cf. figure 7 and figure 11). Before the agitating means 38 are activated to mix the content of said container section 13a in the first compartment 25, the cap manipulating means has to be activated to move the cap 19 of this container section 13a in the opening position (cf. fig. 9b). Then the vertical drive means 45 may be activated to lower the stirrer 37 so as to insert said stirrer 37 through the uncovered opening 17 into the inner volume of the container section 13a, in order to agitate the reagent contained therein. The rotation of the propeller 51 of the stirrer 37 about its vertical axis is controllable by the control means.

[0077] As mentioned above, the container section 13a contains a bead suspension which must be homogenized by mixing before it is extracted by a pipetting unit 39, 41 for use in an analysis step. This step of agitating the suspension of beads is also called a bead mixing step. The bead mixing step is usually more time consuming than pipetting steps of the pipetting means 40. For this reason the apparatus for providing reagents according to figure 8 will be operated in such a manner that each bead mixing operation will be performed on the second turntable partition 5 with the container section 13a of the particular reagent container assembly 11 is positioned on the radial innermost location of the first compartment 25.

[0078] During the bead mixing step the first turntable partition 3 may be driven by its drive means to rotate in order to adjust a reagent container assembly 11 in a predetermined position in the treatment zone 23. Also the pipetting means 40 may be operated during the bead mixing step is performed. The pipetting means 40 is used to extract reagents from reagent container assemblies 11 currently adjusted in the treatment zone 23. The pipetting means 40 may be moved along its horizontal guidance 43 to selectively access in the treatment zone 23 container sections 13a, 13b, 13c in the first compartment 25 of the second turntable partition 5 or container sections 13a, 13b, 13c of a reagent container assembly 11 in a respective compartment 9a of the first turntable partition 3. After the current bead mixing step has been terminated and the stirrer 37 has been retracted from the container section 13a of the respective reagent container assembly 11 in the first compartment 25, this reagent container assembly 11 may be transferred to the first turntable partition 3 by radially shifting the reagent container assembly 11 outwards into a vacant compartment of the first turntable partition 3 by means of the container shift mechanism 29.

[0079] It is to be noted that at the same time both radially aligned compartments 9a, 25 in the treatment zone 23 may be occupied by a respective reagent container assembly 11, and that during the stirrer 37 of the agitating means 38 is activated to mix the content of container section 13a of the reagent container assembly 11 in the compartment 25 of the second turntable partition 5, the pipetting means 40 may be used to extract reagents from container sections 13a, 13b, 13c of the reagent container assembly 11 in the compartment 9a of the first turntable partition 3.

[0080] Catch springs 53, 54 are provided as snapping means on the vertical compartment dividing walls 55, 56. The catch springs 53 are mounted at an upper and radial inner position to the compartment dividing walls 55 of the second turntable partition 5 so as to be able to snap in an outer recess 57 of the radially innermost positioned container section 13a of a reagent container assembly 11 accommodated in the first compartment 25. The reagent container assembly 11 is automatically or self-adjusted when the catch spring has entered the radially innermost vertical groove or recess 57 of said reagent container assembly 11.

[0081] The catch springs 54 are mounted at an upper and radially outer position to the vertical compartment dividing walls 56 of the first turntable partition 3 in order to snap in a respective groove shaped recess 59 of the reagent container assembly 11 accommodated in the respective compartment 9 of the first turntable partition 3. Instead of the catch springs other snap means may be provided for adjusting the reagent container assemblies 11 in compartments 9, 25, 27.

[0082] The compartments 9, 25, 27 may be equipped with spring-loaded bottom elements (not shown) which are adapted to urge the reagent container assemblies 11 accommodated in the compartments 9, 25, 27 upwardly against upper stops 61 extending from the compartment dividing walls 55, 56. The reagent container assemblies 11 are adjusted precisely also in the vertical direction by this measure. The upper stops 61 are shown in figures 7 - 13 as sidewardly extending protrusions of sheets mounted on top of the compartment dividing walls 55, 56 by means of screws. According to an alternative embodiment of the walls 55, 56 as shown in fig. 15 the stops 61 may be integrated parts of the walls 55, 56, wherein the walls 55, 56 with integrated stops are preferably plastic parts or milled metal parts.

[0083] The container shifting mechanism 29 has a shifting arm 62 with two gripping or engagement elements 63, 65 which are pivotable about the longitudinal axis 67 of the shifting arm 62 between an engagement position and a release position. The gripping elements 63 and 65, respectively, may engage a reagent container assembly 11 at an upper part at respective longitudinal ends thereof. The point of engagement is preferably located at a low level in the upper half of a respective reagent container assembly 11. The radial distance between said gripping elements 63, 65 is a little bit greater

than the length of the reagent container assemblies 11 so that the gripping elements 63, 65 can adopt a reagent container assembly 11 therebetween. By shifting the shifting arm 62 in its longitudinal direction a reagent container assembly 11, that is adopted between the gripping elements 63, 65 in their engagement position, can be transferred between respectively aligned compartments of the first turntable partition 3 and the second turntable partition 5. The container shift mechanism 29 is movable to rotate the shifting arm 62 about the axis of rotation 7 to selectively gain access to each compartment 25, 27 of the second turntable partition 5 in order to transfer reagent container assemblies 11 from each compartment 25, 27 of the second turntable partition 5 to a respective aligned compartment of the first turntable partition 3. According to one embodiment the pivot movement of the elements 63, 65 may be started during the rotation of the shifting arm 62 about the axis 7.

[0084] When the gripping elements 63, 65 are in their release position they do not interfere with reagent container assemblies 11 on the turntable 1, so that the shifting arm 62 can not move a reagent container assembly 11.

[0085] It is to be noted that the container shifting mechanism 29 with its gripping elements 63, 65 can be operated to hold a reagent container assembly 11 in position in a respective compartment 9, 25, 27, e. g. during the opening of the container sections 13a - 13c of that reagent container assembly 11 by means of the automatic cap manipulating mechanism.

[0086] In the perspective view of the container shifting mechanism in figure 14 reference number 71 denotes a drive means for shifting the shifting arm 62 along a horizontal guidance 73 in its longitudinal direction. The reference number 75 denotes a driving means for rotating the shifting arm 62 about its longitudinal axis 67 in order to pivot the gripping elements 63, 65 between their engagement position and release position.

[0087] Reference number 77 in figure 14 denotes a driving means for rotating the container shift mechanism 29 about the vertical axis of rotation 7. The angular positions of the container shifting mechanism 29 relative to the axis of rotation 7 are monitored by means of photoelectric guards 79 which act together with a pattern of merlons 81 distributed on a circular arc around the axis of rotation 7.

[0088] In a similar manner the shift position and the pivot position of the shifting arm 62 are monitored by photo-electric guards.

[0089] The turntable 1 has arranged at its center a vertical tube, e. g. a hollow shaft which forms a drain channel 85 for draining a cleaning fluid of a cleaning station adapted for cleaning the stirrer 37 of the agitating means 38. For this reason, the agitating means 38 is movable along its horizontal guidance 43 between the stand-by position shown in figure 8 and a cleaning position in alignment with the drain channel or tube 85. Usually a cleaning step of the stirrer 37 is required after each bead mixing step.

The provision of the cleaning station in the central region of the turntable is a space-saving measure which avoids long ways between the stand-by position and the cleaning position of the stirrer 37.

[0090] There are also provided cleaning means for cleaning the pipetting tubes 39, 41. The latter cleaning means are positioned outside the turntable 1 and are not shown.

[0091] According to the present invention it is possible to perform more time-consuming treatment steps on the second turntable partition 5 while faster treatment steps, including the rotation of the first turntable partition 1 and pipetting operations of the pipetting units 39, 41, may be performed. The apparatus for providing reagents according to the present invention may be operated very efficiently to achieve a high throughput of the analyzer. As mentioned above the control means is programmed to control the operation of the apparatus for providing reagents according to the particular program for performing a lot of analytical determinations by means of the analyzer.

[0092] It is to be noted that the movements of the reagent container assemblies 11 on the turntable 1, i. e. rotation of the turntable 1 in both rotational directions and the shifting of the reagent container assemblies 11 between the turntable partitions 3 and 5 should be performed without abrupt starts and stops in order to avoid an intensive sloshing of the reagents in the reagent container assemblies 11. Therefore, the controlling means is programmed to control the driving means of the turntable 1 so as to perform the movements of the reagent container assemblies 11 in a harmonic manner. The same applies to the movement of the shift mechanism 29.

[0093] Also the course of movement of the treatment means 38 and 40 is controlled according to a particular scheme in order to achieve a trouble-free and time-optimized operation of the apparatus for providing reagents.

[0094] It is to be noted that in principle all features of the first aspect not being part of the invention may be realized in an analyzer according to the invention and vice versa.

[0095] Reference Numerals of the first embodiment of the invention.

101 Automatic analyzer
 102 Sample dispensing tip reaction vessel disposal hole
 103 Sample dispensing tip buffer
 104 Sample
 105 Reaction solution stirring unit
 106 Sample dispensing tip reaction vessel transport unit
 107 Sample dispensing tip reaction vessel
 108 Incubator disk
 109 Reagent dispensing pipettor
 110 Reagent container
 111 Reagent disk
 112 Reaction solution suction nozzle

113 Detection unit
 114 Sample transport line
 115 Sample dispensing unit
 116 Magnetic particles stirring arm
 5 201 Lid
 202 Jacket
 205 Loading system
 301 Reagent driving disk
 302 Reagent driving disk driving unit
 10 303 Fixed disk
 304 Loading system
 305 Reagent container moving unit
 306 Reagent information reading device
 307 Partition plate
 15 308 Reagent stand-by position
 309 Reagent stirring position
 310 Reagent dispensing position
 401 Reagent placing unit
 402 Reagent actuator
 20 403 Indicator
 404 Loading system locking unit
 405 Indicator lamp
 501 Arm mechanism
 502 Drive portion
 25 503 Arm
 504 Lateral arm drive portion
 505 Rotational arm drive portion
 601 Analysis request process
 602 Confirmation process whether a reagent to be used for an analysis on a reagent driving disk
 30 603 Process for no reagent movement
 604 Confirmation process whether a vacant position presents in a reagent driving disk or not
 605 Process for moving a reagent container from a fixed disk to a reagent driving disk by a reagent moving mechanism
 35 606 Confirmation process whether a vacant position presents in a fixed disk or not
 607 Process for moving a reagent container to a reagent stand-by position by a reagent driving disk
 40 608 Process for moving a reagent container to a loading system by a reagent driving disk
 609 Analysis possible process

45 **[0096]** Reference Numerals of the second embodiment of the invention.

1 turntable
 3 first partition
 50 5 second partition
 7 axis of rotation
 9 compartments
 11 reagent container assembly
 13a, 13b, 13c container sections
 55 15 welding spots
 17 upper opening
 19 cap
 21 hinge

23	treatment zone	
25,27	compartment	
29	container shift mechanism	
31	treating means	
33	frame	5
34	vertical pile	
35	cantilever	
37	stirrer	
37, 39, 41	treatment units	
39, 41	pipetting units	10
38	agitating means	
40	pipetting means	
43	linear horizontal guidance	
44, 47, 49	driving means	
53, 54	Catch springs	15
55, 56	compartment dividing walls	
57	outer recess	
62	shifting arm	
63, 65	gripping or engagement elements	
67	longitudinal axis	20
71, 77	driving means	
73	horizontal guidance	
75	driving means for rotating the shifting arm	
79	photo-electric guards	25
85	drain channel	

Claims

1. Analyzer comprising an apparatus for providing reagents to be used in analyses to be performed by the analyzer,

wherein said apparatus for providing reagents comprises

- a turntable (1; 111) having an axis (7) of rotation and being adapted for storing thereon a plurality of reagent container assemblies (11; 110) in an arrangement of at least one arcuate row,
- at least one treatment zone (23; 309, 310) for treating reagent container assemblies (11; 110) stored on said turntable (1; 111), and
- treatment means (29, 38, 40; 116, 109) for treating reagent container assemblies (11; 110) positioned in said treatment zone (23; 309, 310),
- wherein said turntable (1; 111) comprises compartments (9) arranged to accommodate the reagent container assemblies (11; 110) at predetermined locations on the turntable (1) so as to form said arrangement of at least one arcuate row of reagent container assemblies (11; 110) corresponding to the arrangement of said compartments (9),

- wherein said turntable (1; 111) is adjustable by rotation so as to selectively move compartments (9) in predetermined positions for disposing reagent container assemblies (11; 110) in predetermined positions in said treatment zone (23; 309, 310) and comprises

- a first circular turntable partition (3; 301) centered around the axis of rotation (7) and carrying said arcuate row of compartments (9), and
- a second turntable partition (5; 303) arranged radially adjacent to said first turntable partition (3; 301) and carrying a first compartment (25) for accommodating a reagent container assembly (11; 110) therein,

wherein said first turntable partition (3; 301) is rotatable relative to the second turntable partition (5; 303) about said axis of rotation (7) so as to selectively adjust a compartment (9) of said first turntable partition in radial alignment with said first compartment (25) of the second turntable partition (5) in a mutual transfer position in which a reagent container assembly (11; 110) is radially shiftable between said aligned compartments (9, 25) in said treatment zone (23; 309, 310), and

wherein said treatment means (29, 38, 40; 116, 109) comprise pipetting means (40; 109) movable for access to at least one of reagent container assemblies (11; 110) positioned in said predetermined positions in said treatment zone (23; 310), the pipetting means (40; 109) being configured for extracting a reagent from the at least one of the reagent container assemblies (11; 110) currently adjusted in the treatment zone,

characterized in that

- the second turntable partition (5; 303) is fixed with regard to the axis of rotation (7),
- said treatment means (29, 38, 40; 116, 109) comprise agitating means (38) including a stirrer (37; 116) adapted to access in the treatment zone a reagent container assembly (11; 110) accommodated in the first compartment (25) of the second turntable partition (5; 303) in order to perform an agitating step by agitating a content of the respective container assembly (11; 110) in the first compartment (25; 303) in the treatment zone, and
- **in that** during such an agitating step said first turntable partition (3; 301) is operable to provide other reagent container assemblies (11; 110) in the treatment zone for being treated on a faster time scale by extract-

- ing reagents therefrom by means of said pipetting means independently of the operation of the agitating means.
2. Analyzer according to claim 1, **characterized in that** the first circular turntable partition (3; 301) is arranged radially outward of the second turntable partition (5; 303) with regard to the axis of rotation (7).
 3. Analyzer according to claim 1 or 2, **characterized in that** it further comprises a container shift mechanism (29) for shifting a reagent container assembly (11) between radially aligned compartments (9, 25, 27) of said turntable partitions (3, 5) in their mutual transfer position, wherein said container shift mechanism (29) comprises radially movable engagement means (63, 65) for engaging and shifting a reagent container assembly (11) between compartments (9, 25, 27) in their mutual transfer position.
 4. Analyzer according to claim 3, wherein the container shift mechanism (29) is adapted to be operated in different angular positions beside or outside of the treatment zone (23) section, in which the pipetting means (40) operates, and wherein the container shift mechanism (29) and the pipetting means (40) and the agitating means (38) are selectively operable in order to simultaneously treat separate reagent container assemblies (11) with the container shift mechanism (29), the pipetting means (40) and the agitating means (38), respectively.
 5. Analyzer according to at least one of the preceding claims, **characterized in that** said second turntable partition (5) carries a plurality of compartments (25, 27) including said first compartment (25) for accommodating reagent container assemblies (11) in an arrangement of an arcuate row radially adjacent said arcuate row of compartments (9) of the first turntable partition (3), wherein at least two of the compartments (25, 27), preferably all compartments (25, 27) of said second turntable partition (5) are radially alignable with respective compartments (9) of the first turntable partition (3) in mutual transfer positions.
 6. Analyzer according to claim 5, **characterized in that** said container shift mechanism (29) is movable around the axis of rotation (7) in selected angular positions corresponding to angular positions of the radial alignment of compartments (9, 25, 27) aligned in their mutual transfer positions.
 7. Analyzer according to at least one of the preceding claims, wherein each reagent container assembly (11) consists of at least two, preferably of three container sections (13a, 13b, 13c) each of which has an inner volume containing a particular reagent, where-
- in the container sections (13a, 13b, 13c) are arranged side by side in a row and connected to form a unitary cassette type, each container section (13a, 13b, 13c) having an upper opening (17) and a cap (19) for closing the upper opening (17) of the respective container section (13a, 13b, 13c), wherein said caps (19) being selectively and reversibly displaceable from a closing position in an opening position in order to uncover the openings (17) of the container sections (13a, 13b, 13c), **characterized in that** said treating means comprise at least one cap manipulating mechanism for selectively displacing caps (19) of reagent container assemblies (11) into their opening position and closing position, respectively.
8. Analyzer according to at least one of the preceding claims, wherein one of the compartments (9) of the first turntable partition (3) and at least one of the compartments (25, 27) of the second turntable partition (5) are radially alignable to dispose reagent container assemblies (11) contained therein on a straight radial line when positioned relative to each other in said predetermined positions in the treatment zone (23), and that said apparatus for providing reagents comprises a driving and guiding means (43, 44, 47, 49) for selectively moving said pipetting means to reagent container assemblies (11) positioned relative to each other in said predetermined positions in the treatment zone (23).
 9. Analyzer according to claim 8, **characterized in that** said pipetting means (40) comprise at least two pipetting units (39, 41) and **in that** said driving and guiding means (43, 44, 47, 49) are adapted to selectively move each pipetting unit (39, 41) according to a specific treatment program.
 10. Analyzer according to at least one of the preceding claims, **characterized in that** the agitating means (38) and the pipetting means (40) are simultaneously operable in order to simultaneously treat separate reagent container assemblies (11) with the agitating means (38) and the pipetting means (40).
 11. Analyzer according to at least one of the preceding claims, **characterized by** a control means for controlling the apparatus for providing reagents according to a predetermined program for performing analytical determinations by means of the analyzer.
 12. Analyzer according to at least one of the preceding claims, **characterized in that** the turntable (1) has a radial inner center including the axis of rotation (7), wherein a cleaning station for cleaning treatment means (37, 38) and a drain channel (85) for draining cleaning fluid is arranged in the area of said radial inner center.

13. Analyzer according to claim 12, **characterized in that** said agitating means (37, 38) is movable between a working position to agitate fluid in a reagent container assembly (11) positioned in the first compartment (25) of the second turntable partition and a cleaning position to be cleaned by said cleaning means of said cleaning station.

Patentansprüche

1. Analysator, umfassend einen Apparat zum Bereitstellen von Reagenzien zur Verwendung in Analysen, die von dem Analysator durchgeführt werden sollen, wobei der Apparat zum Bereitstellen von Reagenzien Folgendes umfasst

- einen Drehtisch (1; 111), der eine Rotationsachse (7) aufweist und zum Lagern einer Vielzahl von Reagensbehältern (11; 110) in einer Anordnung von mindestens einer bogenförmigen Reihe ausgelegt ist,
- mindestens eine Behandlungszone (23; 309, 310) zum Behandeln von Reagensbehältern (11; 110), die auf dem Drehtisch (1; 111) gelagert sind, und
- Behandlungseinrichtungen (29, 38, 40; 116, 109) zum Behandeln von Reagensbehältern (11; 110), die in der Behandlungszone (23; 309, 310) positioniert sind,
- wobei der Drehtisch (1; 111) Fächer (9) umfasst, die zur Aufnahme der Reagensbehälter (11; 110) an vorbestimmten Stellen auf dem Drehtisch (1) angeordnet sind, sodass sie die Anordnung von mindestens einer bogenförmigen Reihe von Reagensbehältern (11; 110) bilden, die der Anordnung der Fächer (9) entspricht,
- wobei der Drehtisch (1; 111) durch Rotation so eingestellt werden kann, dass er Fächer (9) selektiv in vorbestimmte Positionen bewegt, sodass Reagensbehälter (11; 110) in vorbestimmten Positionen in der Behandlungszone (23; 309, 310) abgelegt werden, und Folgendes umfasst
- eine erste kreisförmige Drehtischteilung (3; 301), die um die Rotationsachse (7) zentriert ist und die bogenförmige Reihe von Fächern (9) trägt, und
- eine zweite Drehtischteilung (5; 303), die radial angrenzend an die erste Drehtischteilung (3; 301) angeordnet ist und ein erstes Fach (25) zum Aufnehmen eines Reagensbehältersatzes (11; 110) darin trägt,

wobei die erste Drehtischteilung (3; 301) bezogen auf die zweite Drehtischteilung (5; 303) um die Rotationsachse (7) drehbar ist,

sodass selektiv ein Fach (9) der ersten Drehtischteilung in radialer Ausrichtung mit dem ersten Fach (25) der zweiten Drehtischteilung (5) in einer wechselseitigen Übergabeposition, in der ein Reagensbehältersatz (11; 110) radial zwischen den ausgerichteten Fächern (9, 25) in der Behandlungszone (23; 309, 310) verschiebbar ist, eingestellt wird, und
wobei die Behandlungseinrichtungen (29, 38, 40; 116, 109) Pipettiereinrichtungen (40; 109) umfassen, die für Zugriff auf mindestens einen von Reagensbehältern (11; 110), die in den vorbestimmten Positionen in der Behandlungszone (23; 310) positioniert sind, beweglich sind, wobei die Pipettiereinrichtungen (40; 109) zum Extrahieren eines Reagens aus dem mindestens einen der Reagensbehälter (11; 110), die aktuell in der Behandlungszone eingestellt sind, ausgebildet sind,

dadurch gekennzeichnet, dass

- die zweite Drehtischteilung (5; 303) in Bezug auf die Rotationsachse (7) fixiert ist,
 - die Behandlungseinrichtungen (29, 38, 40; 116, 109) Bewegungseinrichtungen (38) umfassen, die einen Rührer (37; 116) einschließen, der zum Zugreifen in der Behandlungszone auf einen Reagensbehältersatz (11; 110), der in dem ersten Fach (25) der zweiten Drehtischteilung (5; 303) aufgenommen ist, ausgelegt ist, um einen Bewegungsschritt durch Bewegen eines Inhalts des jeweiligen Behältersatzes (11; 110) in dem ersten Fach (25, 303) in der Behandlungszone auszuführen, und
 - dass während eines solchen Bewegungsschrittes die erste Drehtischteilung (3; 301) so bedient werden kann, dass andere Reagensbehälter (11; 110) in der Behandlungszone zur Behandlung in einem schnelleren Zeitrahmen durch Entnehmen von Reagenzien daraus mittels der Pipettiereinrichtungen unabhängig vom Betrieb der Bewegungseinrichtungen bereitgestellt werden.
2. Analysator nach Anspruch 1, **dadurch gekennzeichnet, dass** die erste kreisförmige Drehtischteilung (3; 301) radial außerhalb der zweiten Drehtischteilung (5; 303) in Bezug auf die Rotationsachse (7) angeordnet ist.
3. Analysator nach Anspruch 1 oder 2, **dadurch gekennzeichnet, dass** er ferner einen Behälterverschiebemechanismus (29) zum Verschieben eines Reagensbehältersatzes (11) zwischen radial ausgerichteten Fächern (9, 25, 27) der Drehtischteilungen (3, 5) in ihrer wechselseitigen Übergabeposition um-

- fasst, wobei der Behälterverschiebemechanismus (29) radial bewegliche Eingriffeinrichtungen (63, 65) zum Eingreifen und Verschieben eines Reagensbehältersatzes (11) zwischen Fächern (9, 25, 27) in ihrer wechselseitigen Übergabeposition umfasst.
- 5
4. Analysator nach Anspruch 3, wobei der Behälterverschiebemechanismus (29) dafür ausgelegt ist, in verschiedenen Winkelpositionen neben oder außerhalb des Behandlungszonenbereiches (23), in dem die Pipettiereinrichtungen (40) arbeiten, betrieben zu werden und wobei der Behälterverschiebemechanismus (29) und die Pipettiereinrichtungen (40) und die Bewegungseinrichtungen (38) selektiv betrieben werden können, um separate Reagensbehältersätze (11) mit dem Behälterverschiebemechanismus (29), den Pipettiereinrichtungen (40) bzw. den Bewegungseinrichtungen (38) gleichzeitig zu behandeln.
- 10
5. Analysator nach mindestens einem der vorstehenden Ansprüche, **dadurch gekennzeichnet, dass** die zweite Drehtischteilung (5) eine Vielzahl von Fächern (25, 27), die das erste Fach (25) zum Aufnehmen von Reagensbehältersätzen (11) einschließt, in einer Anordnung einer bogenförmigen Reihe radial angrenzend an die bogenförmige Reihe von Fächern (9) der ersten Drehtischteilung (3) trägt, wobei mindestens zwei der Fächer (25, 27), vorzugsweise alle Fächer (25, 27) der zweiten Drehtischteilung (5) nach jeweiligen Fächern (9) der ersten Drehtischteilung (3) in wechselseitigen Übergabepositionen radial ausgerichtet werden können.
- 15
6. Analysator nach Anspruch 5, **dadurch gekennzeichnet, dass** der Behälterverschiebemechanismus (29) um die Rotationsachse (7) in ausgewählten Winkelpositionen, die Winkelpositionen der radialen Ausrichtung von Fächern (9, 25, 27) entsprechen, die in ihren wechselseitigen Übergabepositionen ausgerichtet sind, beweglich ist.
- 20
7. Analysator nach mindestens einem der vorstehenden Ansprüche, wobei jeder Reagensbehältersatz (11) aus mindestens zwei, vorzugsweise drei Behälterbereichen (13a, 13b, 13c) besteht, die jeweils ein Innenvolumen aufweisen, das ein bestimmtes Reagens enthält, wobei die Behälterbereiche (13a, 13b, 13c) nebeneinander in einer Reihe angeordnet und unter Bildung einer Kassetteneinheit verbunden sind, wobei jeder Behälterbereich (13a, 13b, 13c) eine obere Öffnung (17) und eine Kappe (19) zum Schließen der oberen Öffnung (17) des jeweiligen Behälterbereiches (13a, 13b, 13c) aufweist, wobei die Kappen (19) selektiv und reversibel aus einer Schließposition in eine Öffnungsposition verlagert werden können, um die Öffnungen (17) der Behälterbereiche (13a, 13b, 13c) aufzudecken, **dadurch**
- 25
- gekennzeichnet, dass die Behandlungseinrichtungen mindestens einen Kappenmanipulationsmechanismus zum selektiven Verlagern der Kappen (19) von Reagensbehältersätzen (11) in ihre Öffnungsposition bzw. Schließposition umfassen.
- 30
8. Analysator nach mindestens einem der vorstehenden Ansprüche, wobei eines der Fächer (9) der ersten Drehtischteilung (3) und mindestens eines der Fächer (25, 27) der zweiten Drehtischteilung (5) radial ausgerichtet werden können, um darin enthaltene Reagensbehältersätze (11) auf einer geraden radialen Linie abzulegen, wenn sie bezogen aufeinander in den vorbestimmten Positionen in der Behandlungszone (23) positioniert sind, und dass der Apparat zum Bereitstellen von Reagenzien eine Antriebs- und Führungseinrichtung (43, 44, 47, 49) zum selektiven Bewegen der Pipettiereinrichtungen zu Reagensbehältersätzen (11), die bezogen aufeinander in den vorbestimmten Positionen in der Behandlungszone (23) positioniert sind, umfasst.
- 35
9. Analysator nach Anspruch 8, **dadurch gekennzeichnet, dass** die Pipettiereinrichtungen (40) mindestens zwei Pipettiereinheiten (39, 41) umfassen und dass die Antriebs- und Führungseinrichtungen (43, 44, 47, 49) zum selektiven Bewegen jeder Pipettiereinheit (39, 41) gemäß einem speziellen Behandlungsprogramm ausgelegt sind.
- 40
10. Analysator nach mindestens einem der vorstehenden Ansprüche, **dadurch gekennzeichnet, dass** die Bewegungseinrichtungen (38) und die Pipettiereinrichtungen (40) gleichzeitig betrieben werden können, um separate Reagensbehältersätze (11) gleichzeitig mit den Bewegungseinrichtungen (38) und den Pipettiereinrichtungen (40) zu behandeln.
- 45
11. Analysator nach mindestens einem der vorstehenden Ansprüche, **gekennzeichnet durch** eine Steuerungseinrichtung zum Steuern des Apparats zum Bereitstellen von Reagenzien gemäß einem vorbestimmten Programm zum Ausführen analytischer Bestimmungen mittels des Analysators.
- 50
12. Analysator nach mindestens einem der vorstehenden Ansprüche, **dadurch gekennzeichnet, dass** der Drehtisch (1) ein radiales inneres Zentrum aufweist, das die Rotationsachse (7) einschließt, wobei eine Reinigungsstation zum Reinigen von Behandlungseinrichtungen (37, 38) und ein Ablasskanal (85) zum Ablassen von Reinigungsflüssigkeit in dem Bereich des radialen inneren Zentrums angeordnet ist.
- 55
13. Analysator nach Anspruch 12, **dadurch gekennzeichnet, dass** die Bewegungseinrichtung (37, 38) zwischen einer Arbeitsposition zum Bewegen von

Fluid in einem Reagensbehältersatz (11), der in dem ersten Fach (25) der zweiten Drehtischteilung positioniert ist, und einer Reinigungsposition zum Reinigen mit der Reinigungseinrichtung der Reinigungsstation beweglich ist.

5

Revendications

1. Analyseur comprenant un appareil pour la fourniture de réactifs à utiliser dans des analyses à réaliser par l'analyseur, dans lequel ledit appareil pour la fourniture de réactifs comprend

10

- un plateau tournant (1 ; 111) ayant un axe (7) de rotation et étant adapté pour le stockage sur celui-ci d'une pluralité d'ensembles de récipients de réactif (11 ; 110) dans un agencement d'au moins une rangée arquée,

15

- au moins une zone de traitement (23 ; 309, 310) pour le traitement d'ensembles de récipients de réactif (11 ; 110) stockés sur ledit plateau tournant (1 ; 111), et

20

- des moyens de traitement (29, 38, 40 ; 116, 109) pour le traitement d'ensembles de récipients de réactif (11 ; 110) positionnés dans ladite zone de traitement (23 ; 309, 310),

25

- dans lequel ledit plateau tournant (1 ; 111) comprend des compartiments (9) agencés pour accueillir les ensembles de récipients de réactif (11 ; 110) au niveau d'emplacements prédéterminés sur le plateau tournant (1) de sorte à former ledit agencement d'au moins une rangée arquée d'ensembles de récipients de réactif (11 ; 110) correspondant à l'agencement desdits compartiments (9),

30

- dans lequel ledit plateau tournant (1 ; 111) est ajustable par rotation de sorte à déplacer sélectivement les compartiments (9) dans des positions prédéterminées pour la disposition des ensembles de récipients de réactif (11 ; 110) dans des positions prédéterminées dans ladite zone de traitement (23 ; 309, 310) et comprend

35

- une première séparation de plateau tournant (3 ; 301) circulaire centrée autour de l'axe de rotation (7) et portant ladite rangée arquée de compartiments (9), et

40

- une seconde séparation de plateau tournant (5 ; 303) agencée radialement adjacente à ladite première séparation de plateau tournant (3 ; 301) et portant un premier compartiment (25) pour l'accueil d'un ensemble de récipients de réactif (11 ; 110) à l'intérieur de celui-ci,

45

50

dans lequel ladite première séparation de plateau tournant (3 ; 301) peut tourner par rapport à la seconde séparation de plateau

55

tournant (5 ; 303) autour dudit axe de rotation (7) de sorte à ajuster sélectivement un compartiment (9) de ladite première séparation de plateau tournant dans un alignement radial avec ledit premier compartiment (25) de la seconde séparation de plateau tournant (5) dans une position de transfert mutuelle dans laquelle un ensemble de récipients de réactif (11 ; 110) peut être radialement déplacé entre lesdits compartiments (9, 25) alignés dans ladite zone de traitement (23 ; 309, 310), et

dans lequel lesdits moyens de traitement (29, 38, 40 ; 116, 109) comprennent des moyens de pipetage (40 ; 109) mobiles pour un accès à au moins un des ensembles de récipients de réactif (11 ; 110) positionnés dans lesdites positions prédéterminées dans ladite zone de traitement (23 ; 310), les moyens de pipetage (40 ; 109) étant conçus pour l'extraction d'un réactif depuis l'au moins un des ensembles de récipients de réactif (11 ; 110) actuellement ajustés dans la zone de traitement,

caractérisé en ce que

- la seconde séparation de plateau tournant (5 ; 303) est fixée par rapport à l'axe de rotation (7),

- lesdits moyens de traitement (29, 38, 40 ; 116, 109) comprennent un moyen d'agitation (38) incluant un agitateur (37 ; 116) adapté pour accéder dans la zone de traitement à un ensemble de récipients de réactif (11 ; 110) accueilli dans le premier compartiment (25) de la seconde séparation de plateau tournant (5 ; 303) afin de réaliser une étape d'agitation en agitant un contenu de l'ensemble de récipients (11 ; 110) respectif dans le premier compartiment (25 ; 303) dans la zone de traitement, et

- **en ce que** pendant une telle étape d'agitation ladite première séparation de plateau tournant (3 ; 301) peut fonctionner pour fournir d'autres ensembles de récipients de réactif (11 ; 110) dans la zone de traitement destinés à être traités sur une échelle de temps plus rapide par extraction de réactifs depuis ceux-ci par le biais desdits moyens de pipetage indépendamment du fonctionnement du moyen d'agitation.

2. Analyseur selon la revendication 1, **caractérisé en ce que** la première séparation de plateau tournant (3 ; 301) circulaire est radialement agencée vers l'extérieur de la seconde séparation de plateau tournant (5 ; 303) par rapport à l'axe de rotation (7).

3. Analyseur selon la revendication 1 ou 2, **caractérisé en ce qu'il** comprend en outre un mécanisme de déplacement de récipient (29) pour le déplacement

- d'un ensemble de récipients de réactif (11) entre des compartiments (9, 25, 27) radialement alignés desdites séparations de plateau tournant (3, 5) dans leur position de transfert mutuelle, dans lequel ledit mécanisme de déplacement de récipient (29) comprend des moyens de prise radialement mobiles (63, 65) pour la prise et le déplacement d'un ensemble de récipients de réactif (11) entre les compartiments (9, 25, 27) dans leur position de transfert mutuelle.
4. Analyseur selon la revendication 3, dans lequel le mécanisme de déplacement de récipient (29) est adapté pour fonctionner dans différentes positions angulaires à côté ou à l'extérieur de la section de zone de traitement (23), dans lequel le moyen de pipetage (40) fonctionne, et dans lequel le mécanisme de déplacement de récipient (29) et le moyen de pipetage (40) et le moyen d'agitation (38) peuvent fonctionner sélectivement afin de traiter simultanément des ensembles de récipients de réactif (11) séparés avec respectivement le mécanisme de déplacement de récipient (29), le moyen de pipetage (40) et le moyen d'agitation (38).
5. Analyseur selon au moins l'une des revendications précédentes, **caractérisé en ce que** ladite seconde séparation de plateau tournant (5) porte une pluralité de compartiments (25, 27) incluant ledit premier compartiment (25) pour l'accueil d'ensembles de récipients de réactif (11) dans un agencement d'une rangée arquée radialement adjacente à ladite rangée arquée de compartiments (9) de la première séparation de plateau tournant (3), dans lequel au moins deux des compartiments (25, 27), de préférence tous les compartiments (25, 27) de ladite seconde séparation de plateau tournant (5) peuvent être radialement alignés avec les compartiments (9) respectifs de la première séparation de plateau tournant (3) dans des positions de transfert mutuelles.
6. Analyseur selon la revendication 5, **caractérisé en ce que** ledit mécanisme de déplacement de récipient (29) est mobile autour de l'axe de rotation (7) dans des positions angulaires choisies correspondant à des positions angulaires de l'alignement radial de compartiments (9, 25, 27) alignés dans leurs positions de transfert mutuelles.
7. Analyseur selon au moins l'une des revendications précédentes, dans lequel chaque ensemble de récipients de réactif (11) est constitué d'au moins deux, de préférence de trois sections de récipient (13a, 13b, 13c) dont chacune a un volume interne contenant un réactif particulier, dans lequel les sections de récipient (13a, 13b, 13c) sont agencées côte à côte en une rangée et reliées pour former un type de cassette unitaire, chaque section de récipient (13a, 13b, 13c) ayant une ouverture supérieure (17) et un capuchon (19) pour la fermeture de l'ouverture supérieure (17) de la section de récipient (13a, 13b, 13c) respective, dans lequel lesdits capuchons (19) pouvant être sélectivement et réversiblement déplacés d'une position fermée à une position ouverte afin de dévoiler les ouvertures (17) des sections de récipient (13a, 13b, 13c), **caractérisé en ce que** lesdits moyens de traitement comprennent au moins un mécanisme de manipulation de capuchon pour le déplacement sélectif de capuchons (19) d'ensembles de récipients de réactif (11) respectivement dans leur position d'ouverture et leur position de fermeture.
8. Analyseur selon au moins l'une des revendications précédentes, dans lequel l'un des compartiments (9) de la première séparation de plateau tournant (3) et au moins l'un des compartiments (25, 27) de la seconde séparation de plateau tournant (5) peuvent être radialement alignés pour disposer les ensembles de récipients de réactif (11) contenus à l'intérieur de celui-ci sur une ligne radiale linéaire lorsqu'ils sont positionnés les uns par rapport aux autres dans lesdites positions prédéterminées dans la zone de traitement (23), et que ledit appareil pour la fourniture de réactifs comprend un moyen d'entraînement et de guidage (43, 44, 47, 49) pour le déplacement sélectif desdits moyens de pipetage jusqu'aux ensembles de récipients de réactif (11) positionnés les uns par rapport aux autres dans lesdites positions prédéterminées dans la zone de traitement (23).
9. Analyseur selon la revendication 8, **caractérisé en ce que** lesdits moyens de pipetage (40) comprennent au moins deux unités de pipetage (39, 41) et **en ce que** lesdits moyens d'entraînement et de guidage (43, 44, 47, 49) sont adaptés pour déplacer sélectivement chaque unité de pipetage (39, 41) selon un programme de traitement spécifique.
10. Analyseur selon au moins l'une des revendications précédentes, **caractérisé en ce que** le moyen d'agitation (38) et le moyen de pipetage (40) peuvent fonctionner simultanément afin de traiter simultanément des ensembles de récipients de réactif (11) séparés avec le moyen d'agitation (38) et le moyen de pipetage (40).
11. Analyseur selon au moins l'une des revendications précédentes, **caractérisé par** un moyen de commande pour la commande de l'appareil pour la fourniture de réactifs selon un programme prédéterminé pour la réalisation de déterminations analytiques par le biais de l'analyseur.
12. Analyseur selon au moins l'une des revendications précédentes, **caractérisé en ce que** le plateau tournant (1) a un centre interne radial incluant l'axe de

rotation (7), dans lequel une station de nettoyage pour le nettoyage des moyens de traitement (37, 38) et un canal d'évacuation (85) pour l'évacuation du fluide de nettoyage est agencée dans la zone dudit centre interne radial.

5

- 13.** Analyseur selon la revendication 12, **caractérisé en ce que** ledit moyen d'agitation (37, 38) est mobile entre une position de travail pour agiter le fluide dans un ensemble de récipients de réactif (11) positionné dans le premier compartiment (25) de la seconde séparation de plateau tournant et une position de nettoyage à nettoyer par ledit moyen de nettoyage de ladite station de nettoyage.

10

15

20

25

30

35

40

45

50

55

FIG.1

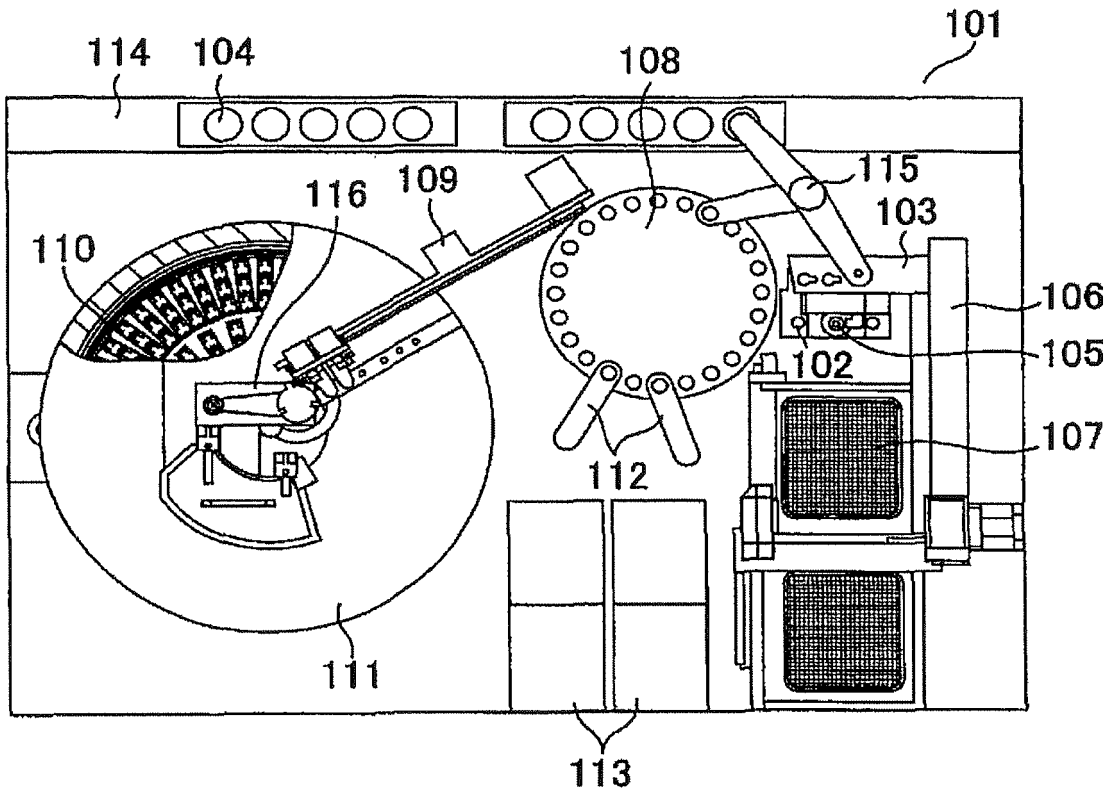

FIG.2

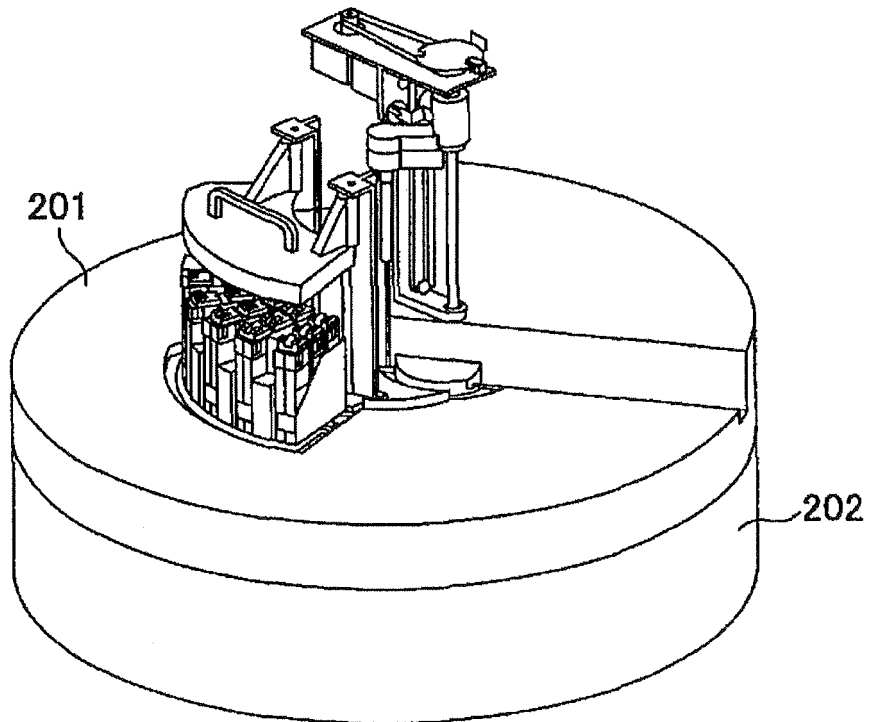

FIG.3-1

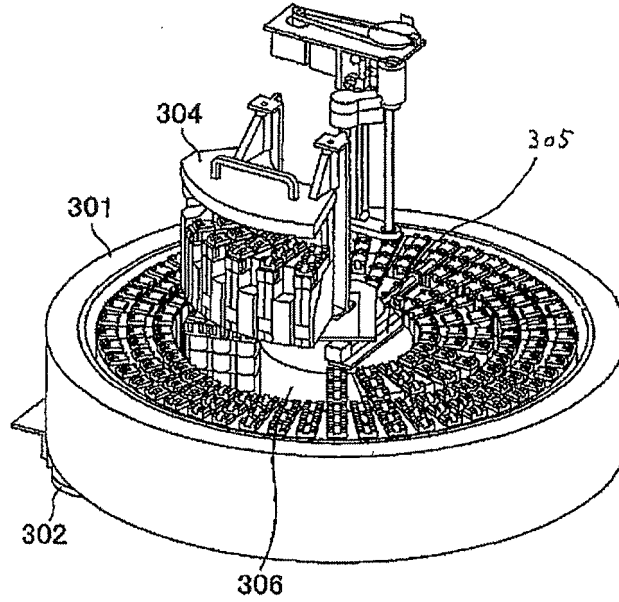

FIG.3-2

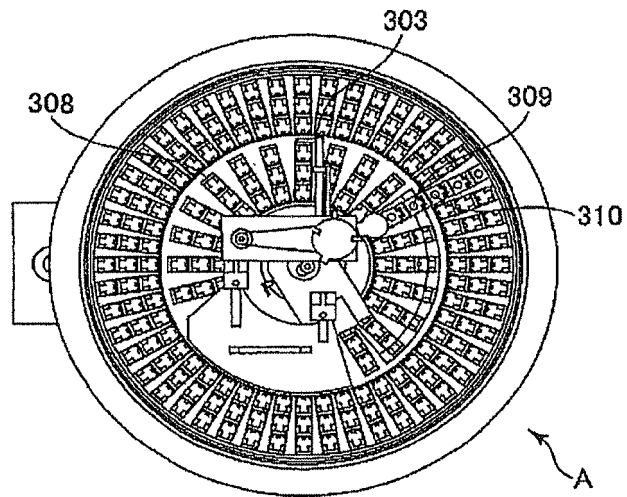

FIG.3-3

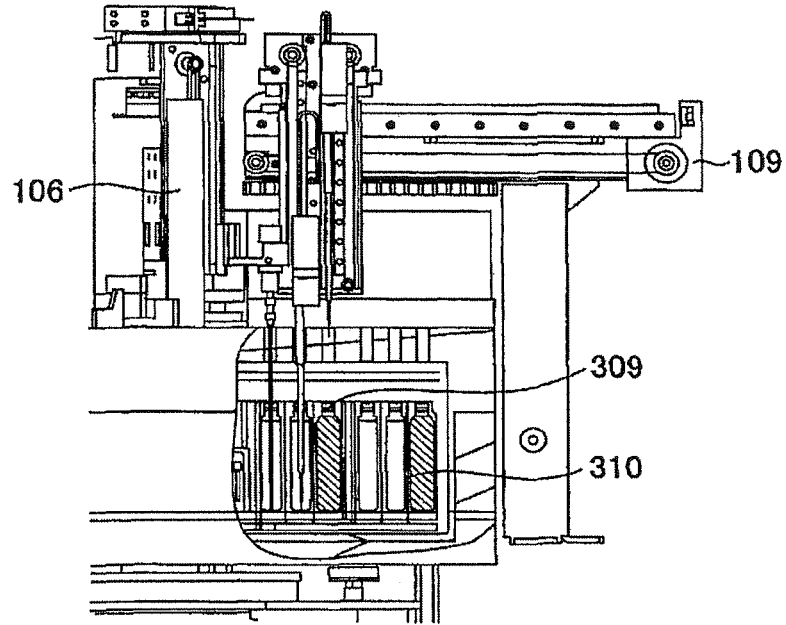

FIG.4

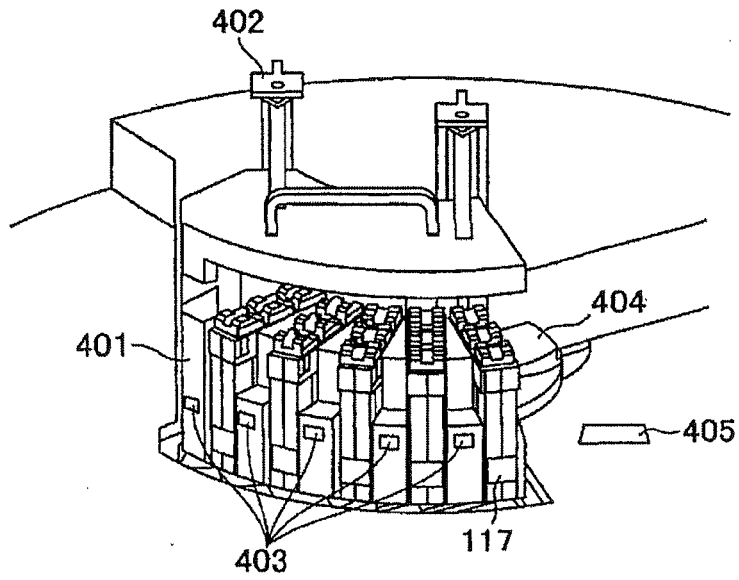

FIG.5

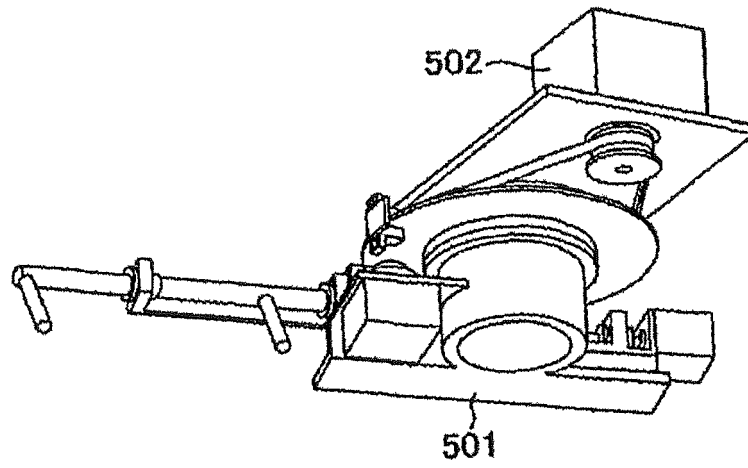

FIG.5-1

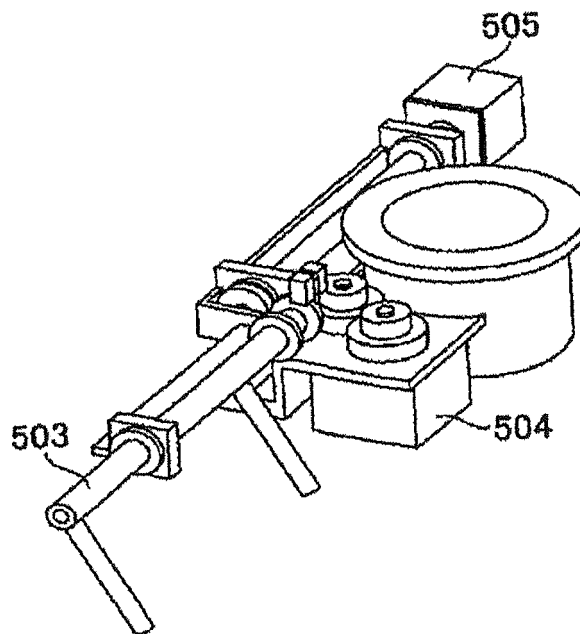
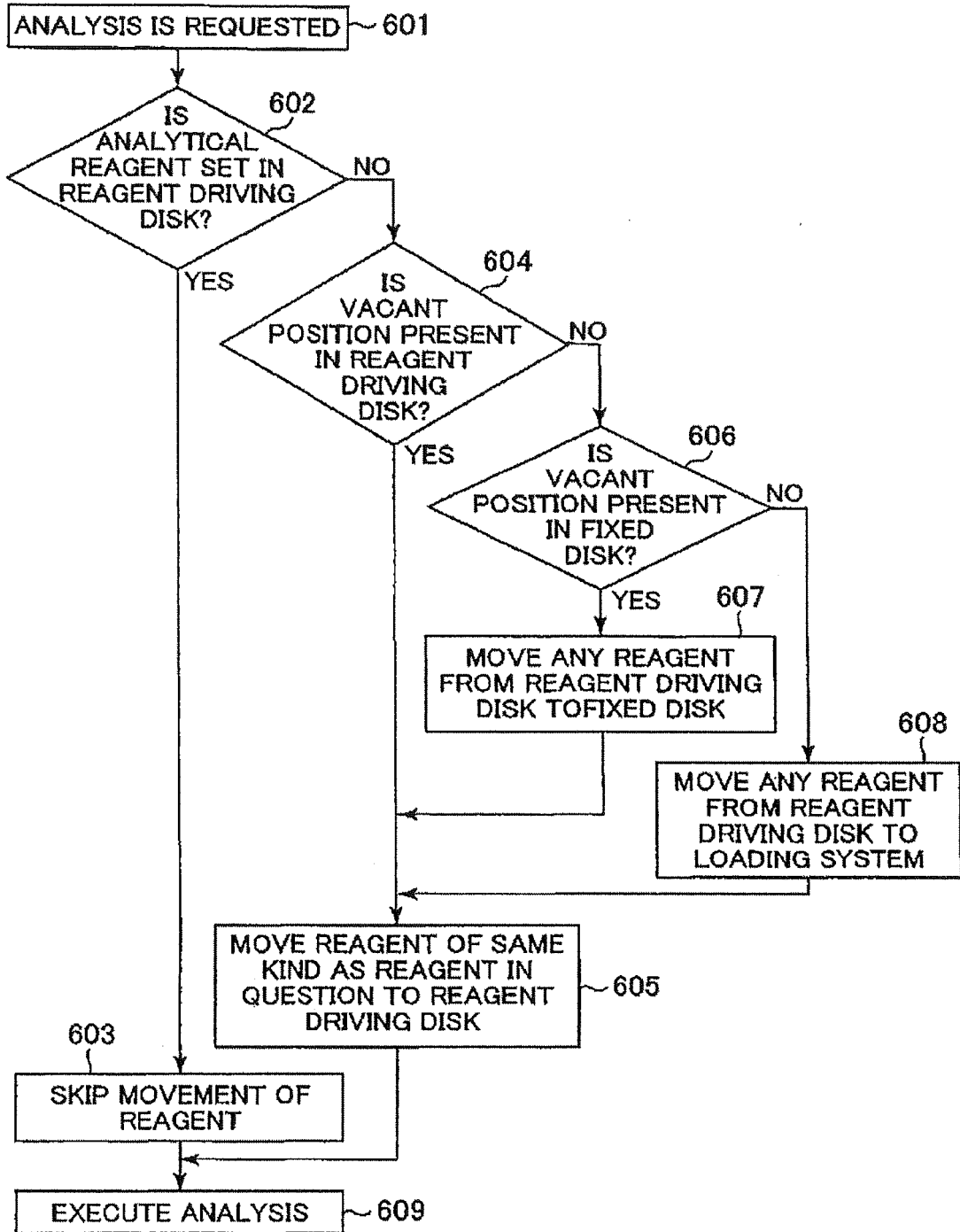

FIG.6



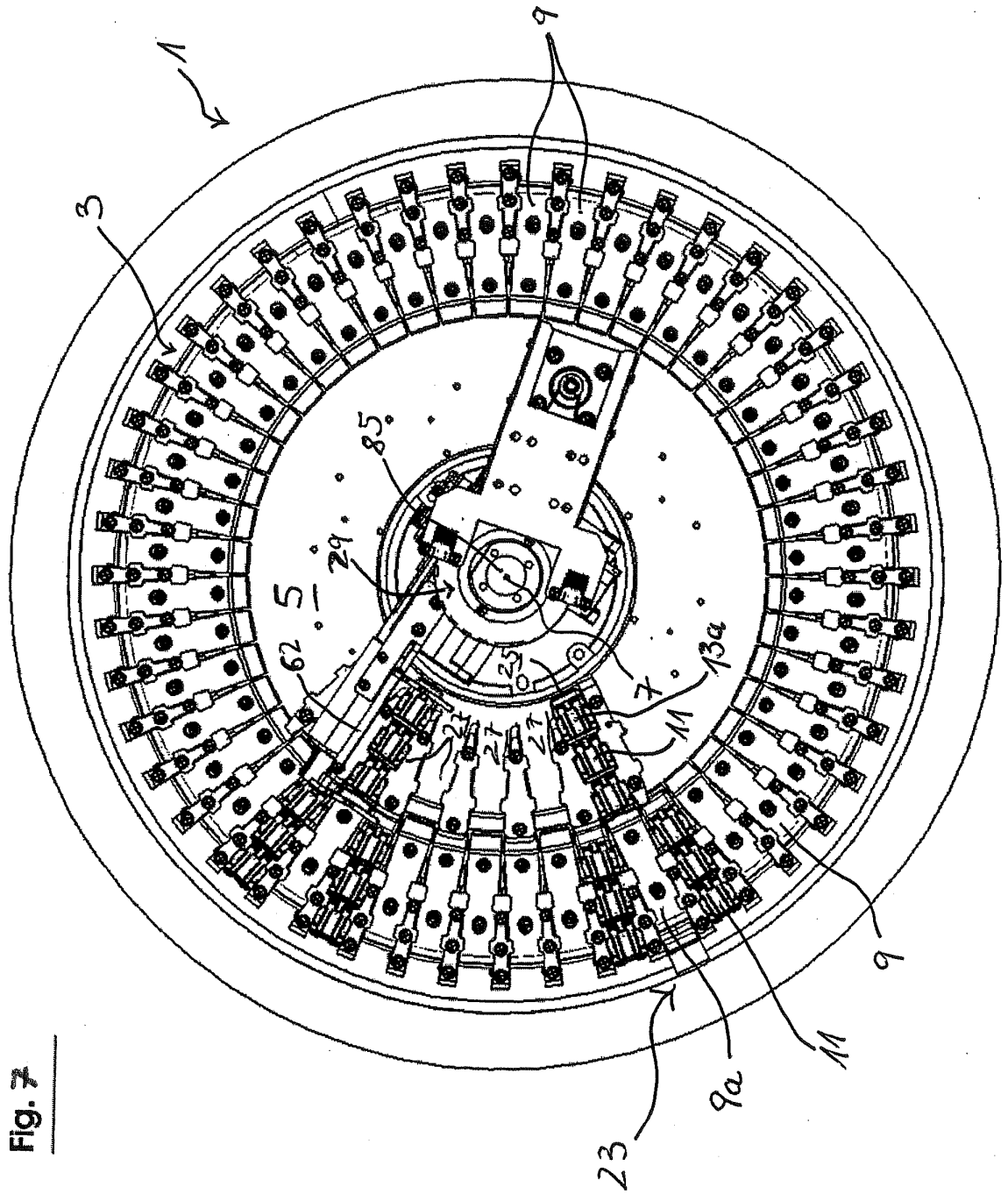

FIG. 7

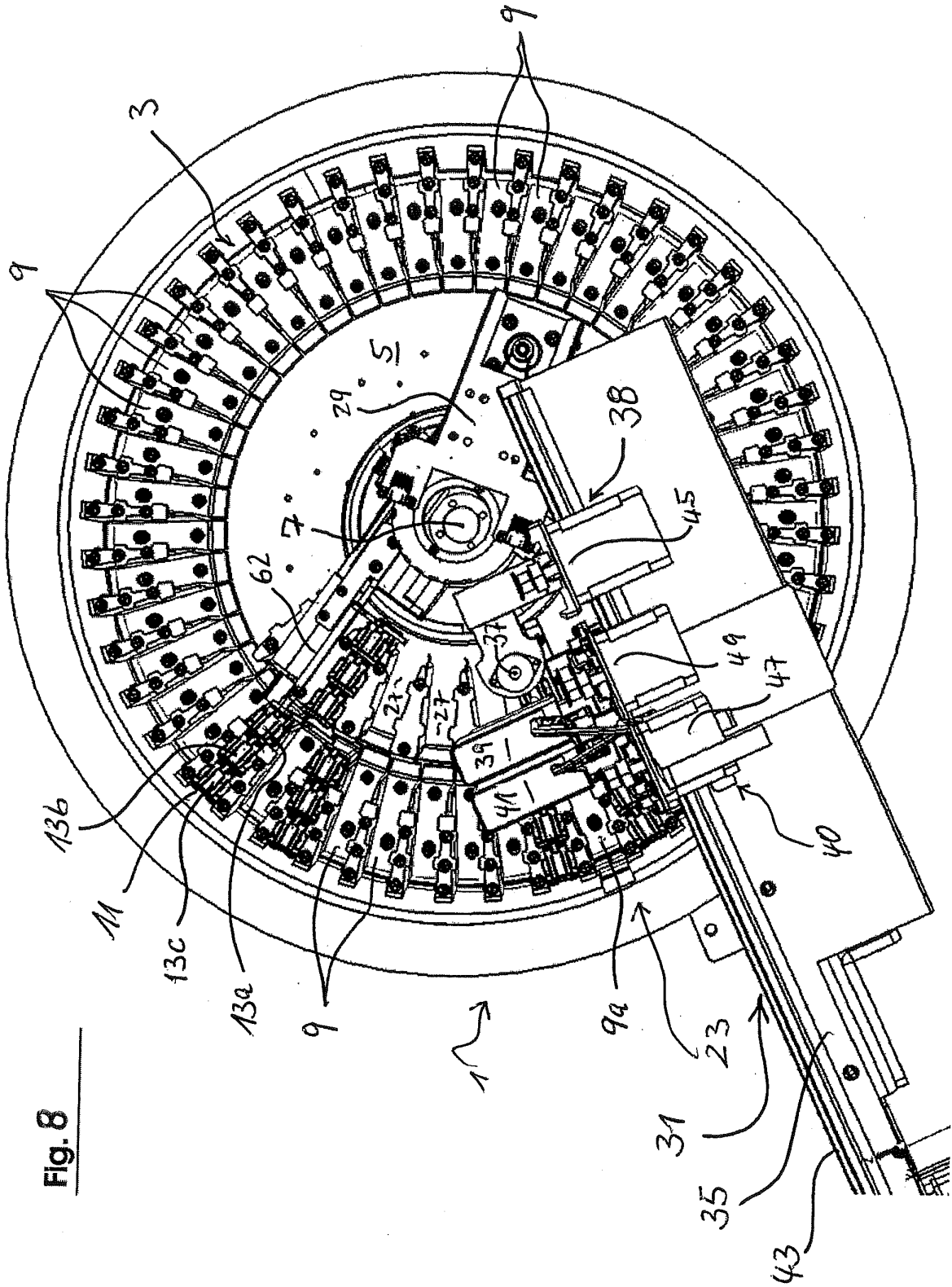
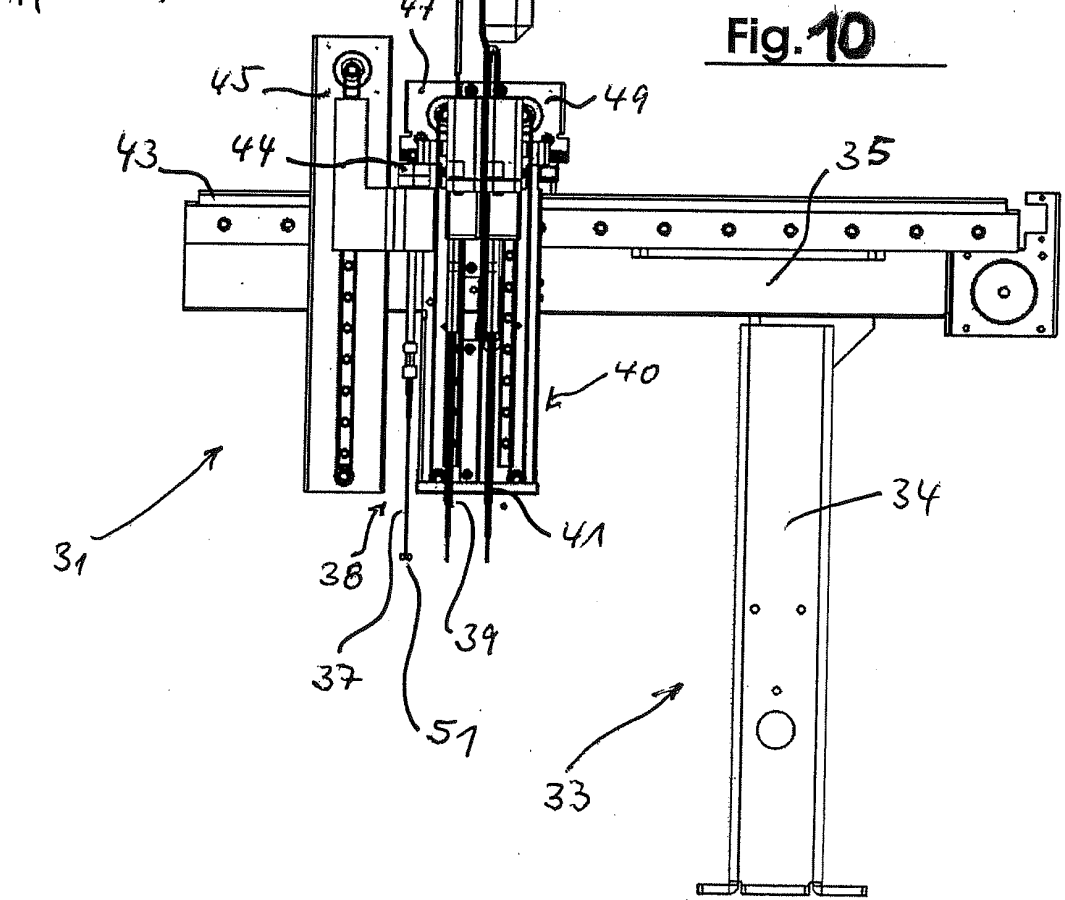
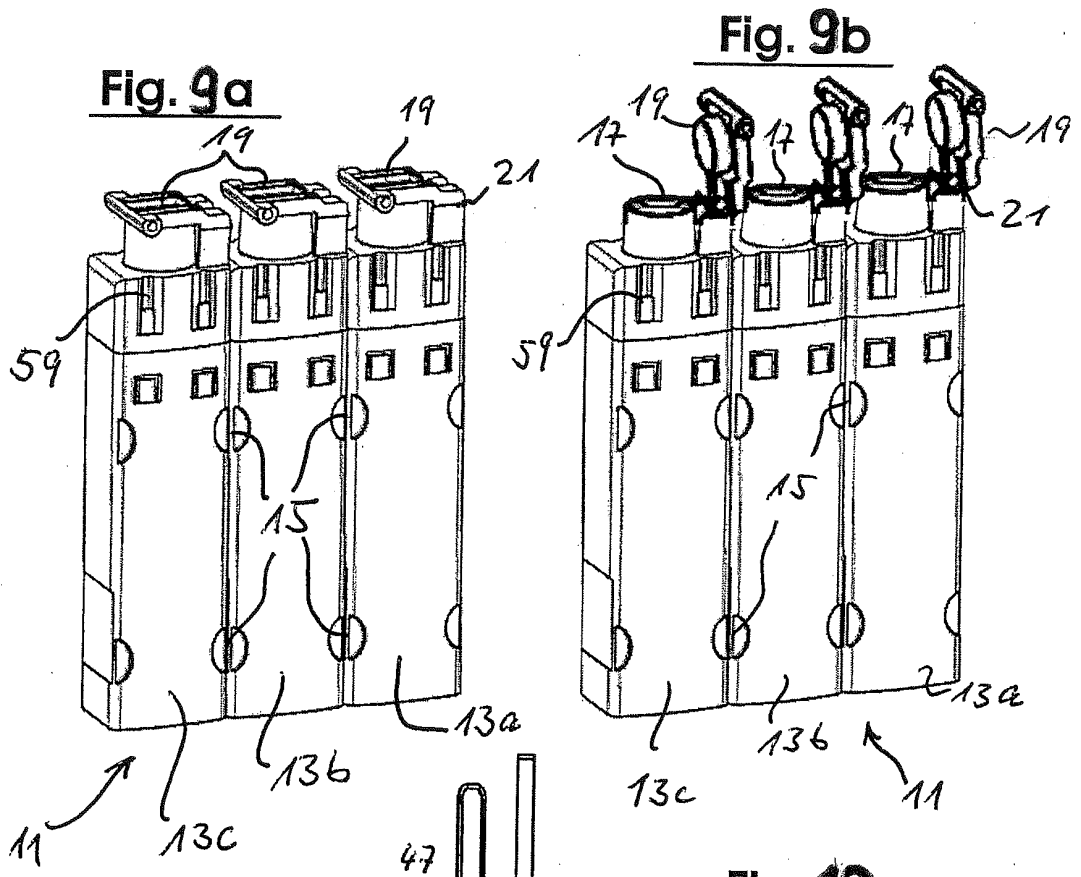

Fig. 8



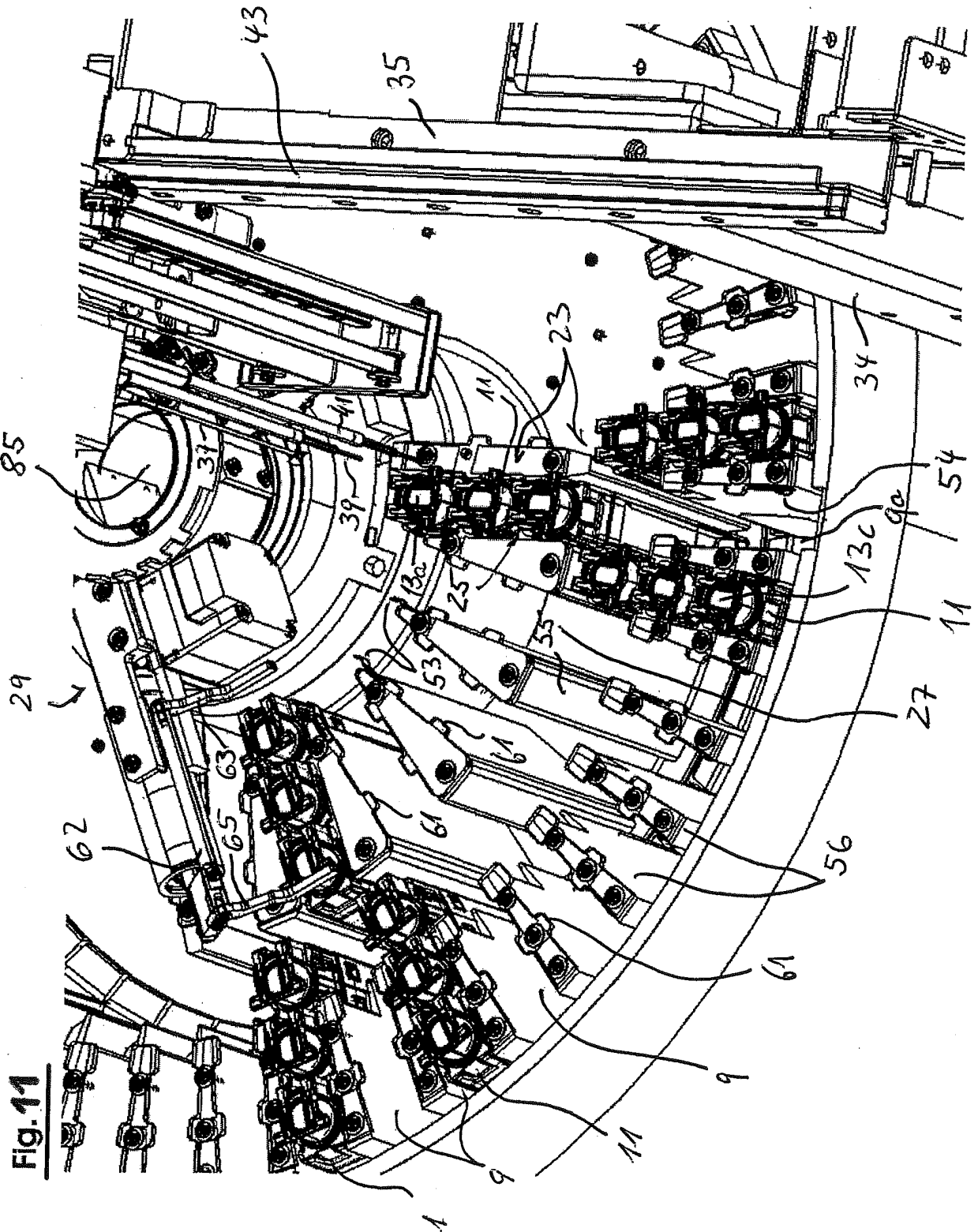

Fig. 11

Fig. 12

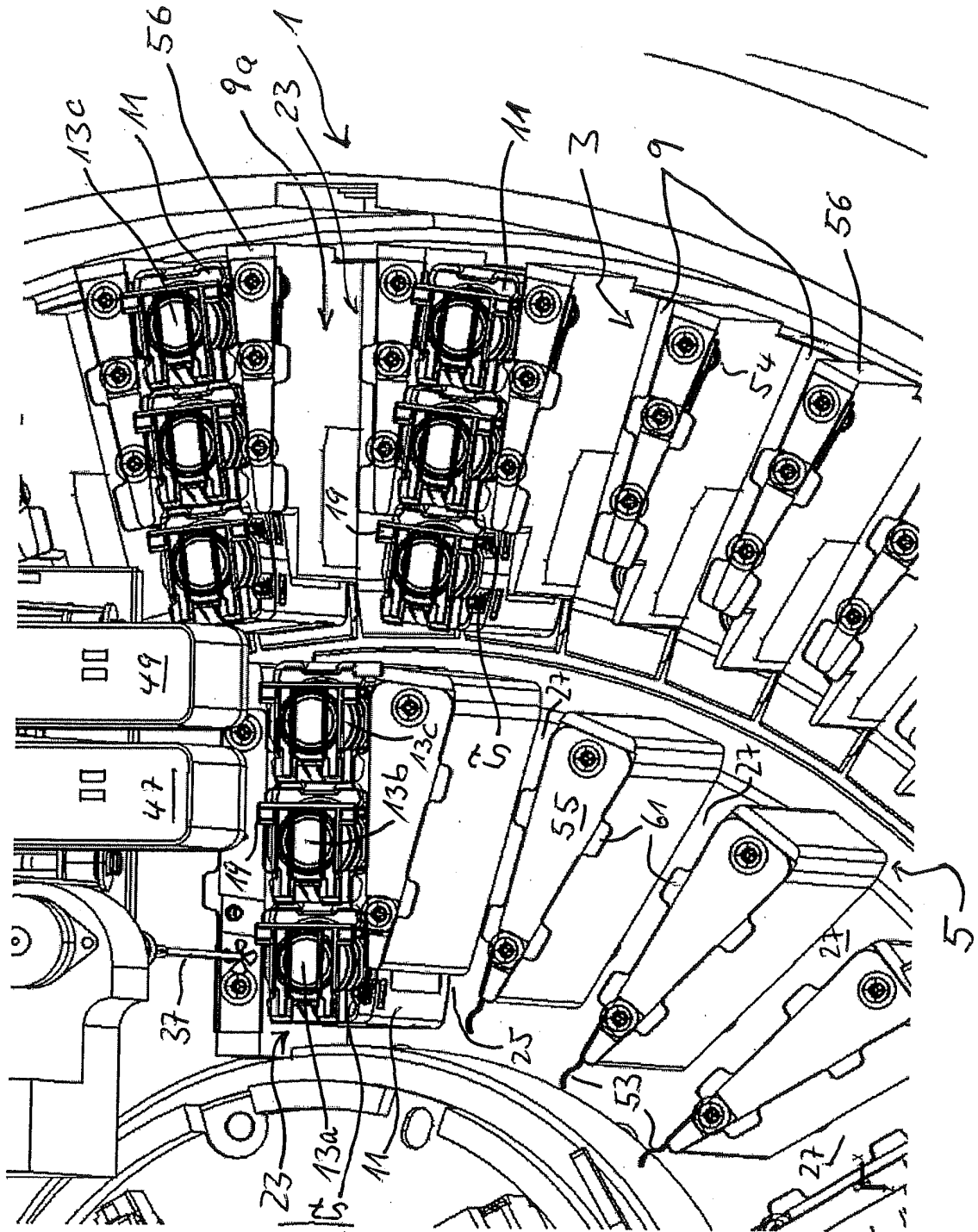
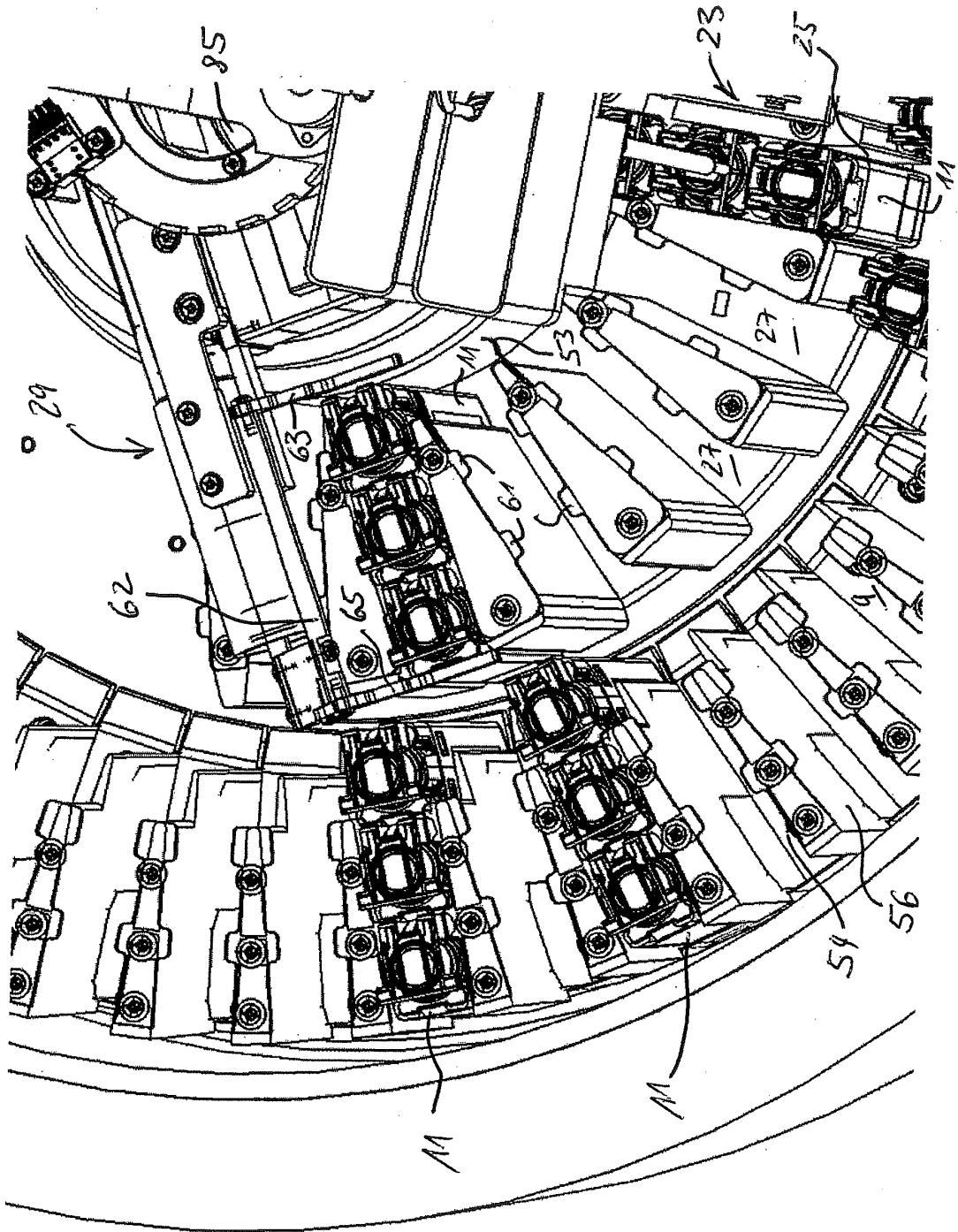

Fig. 13



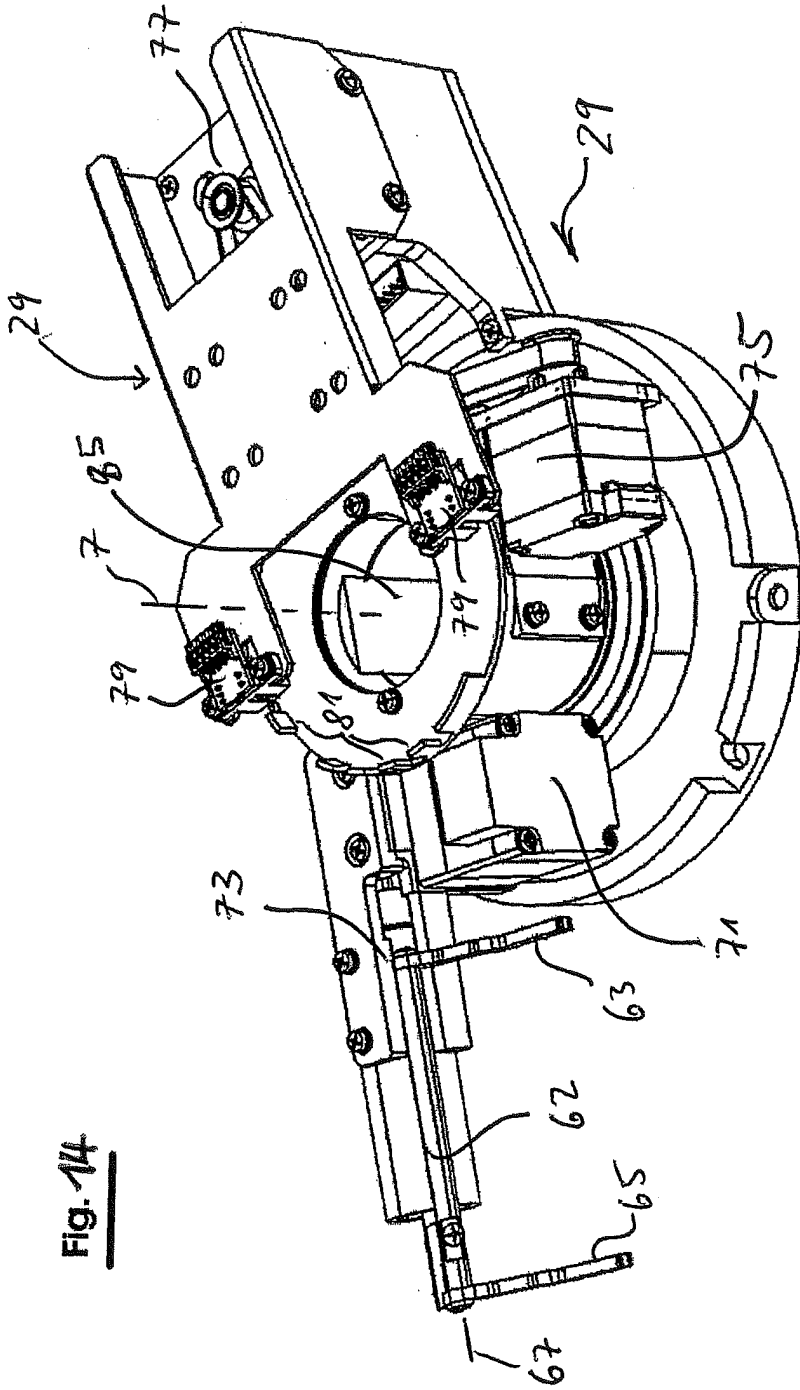

Fig. 14

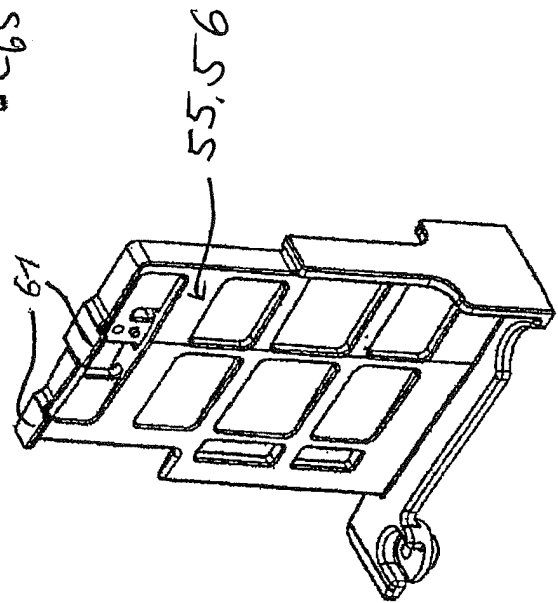

Fig. 15

REFERENCES CITED IN THE DESCRIPTION

This list of references cited by the applicant is for the reader's convenience only. It does not form part of the European patent document. Even though great care has been taken in compiling the references, errors or omissions cannot be excluded and the EPO disclaims all liability in this regard.

Patent documents cited in the description

- JP 4033060 B [0004] [0005] [0006]
- EP 0703457 B1 [0008]
- EP 1275966 B1 [0008]
- US 7547414 B2 [0008]
- US 7384601 B2 [0008]
- EP 1051621 B1 [0010]
- US 20040057872 A1 [0011]
- US 4699766 A [0011]