



US 20160170070A1

(19) **United States**

(12) **Patent Application Publication**
Jachmann et al.

(10) **Pub. No.: US 2016/0170070 A1**

(43) **Pub. Date: Jun. 16, 2016**

(54) **FRONT TANGENTIAL ANTENNA FOR
NUCLEAR MAGNETIC RESONANCE (NMR)
WELL LOGGING**

Publication Classification

(51) **Int. Cl.**
G01V 3/32 (2006.01)
E21B 47/12 (2006.01)

(71) Applicant: **HALLIBURTON ENERGY
SERVICES, INC., Houston, TX (US)**

(52) **U.S. Cl.**
CPC **G01V 3/32** (2013.01); **E21B 47/122**
(2013.01)

(72) Inventors: **Rebecca Jachmann, Houston (US);
George David Goodman, Houston (US)**

(57) **ABSTRACT**

The magnet and antenna assemblies of a logging tool can be arranged according to geometries optimal for concentric or eccentric well logging operations. In an example configuration, a logging tool can include a magnet, a magnetic core made of a magnetically permeable material, and an antenna. The outward path of the antenna can be positioned along a surface of the magnetically permeable magnetic core that faces away from the magnet, and the return path of the antenna can also be positioned along a surface that faces away from the magnet.

(21) Appl. No.: **14/436,857**

(22) PCT Filed: **May 6, 2014**

(86) PCT No.: **PCT/US2014/037027**

§ 371 (c)(1),
(2) Date: **Apr. 17, 2015**

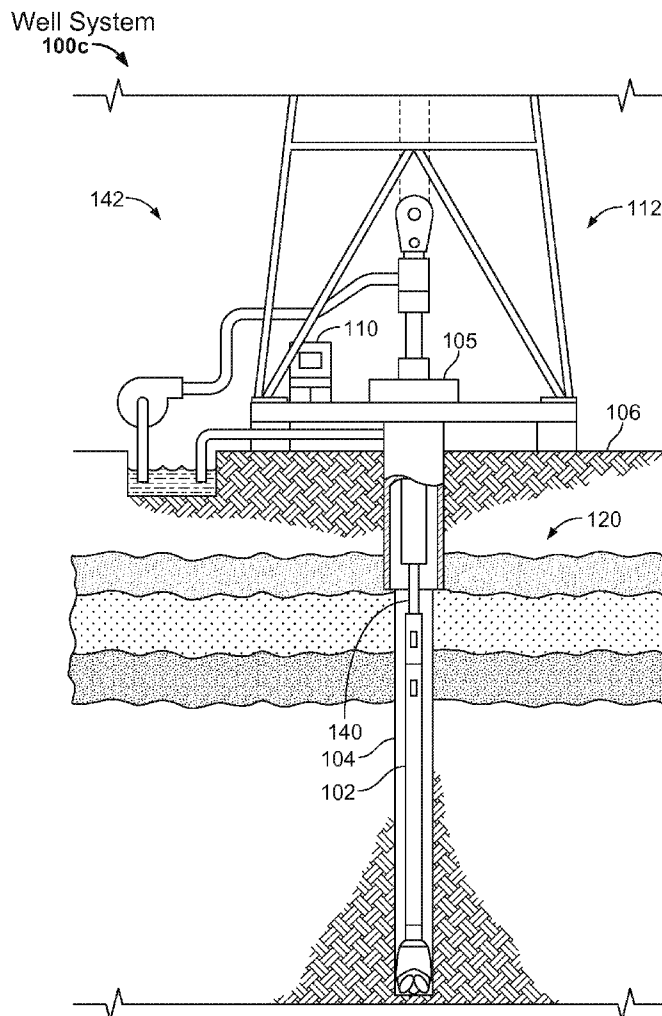

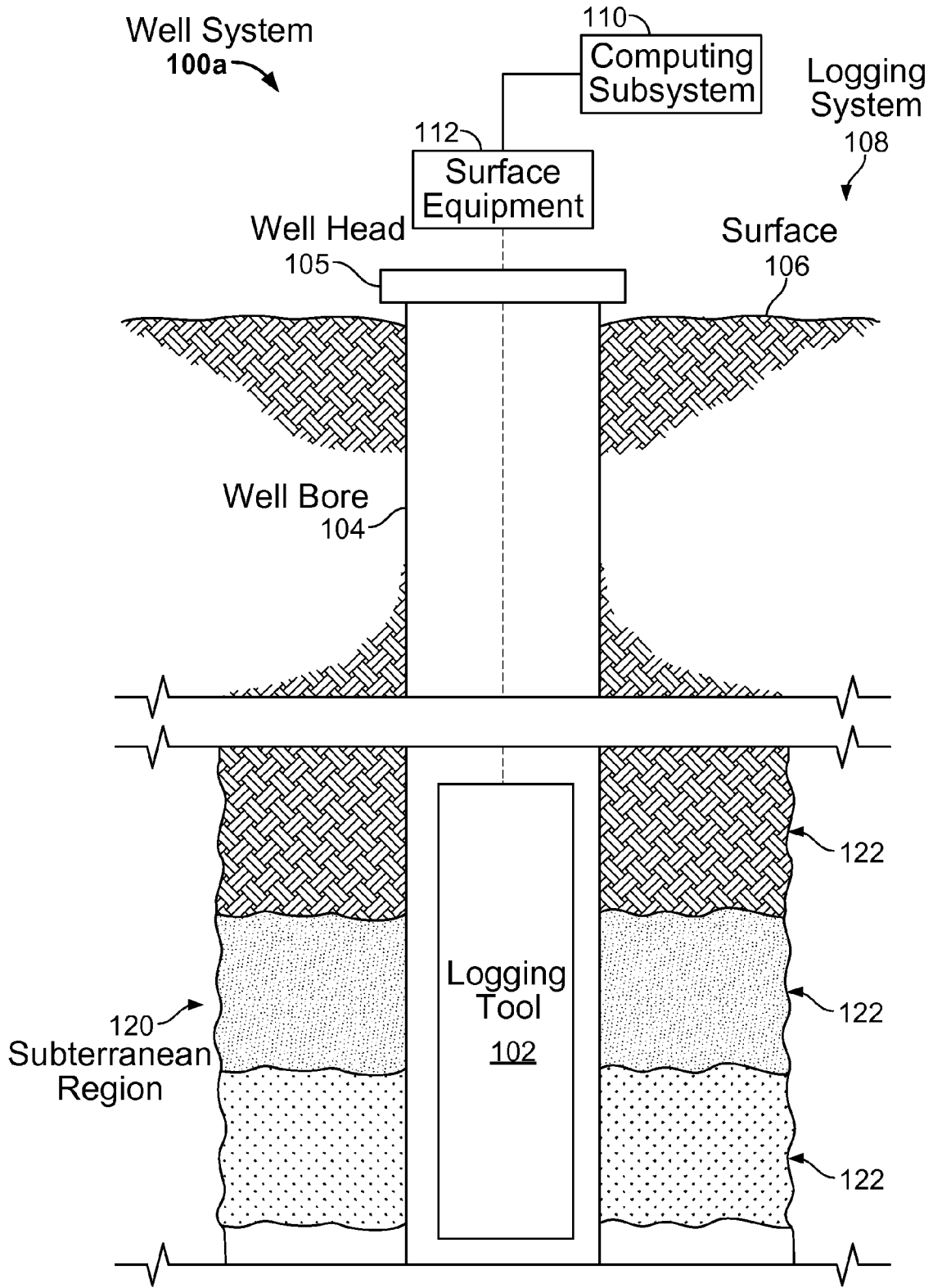

FIG. 1A

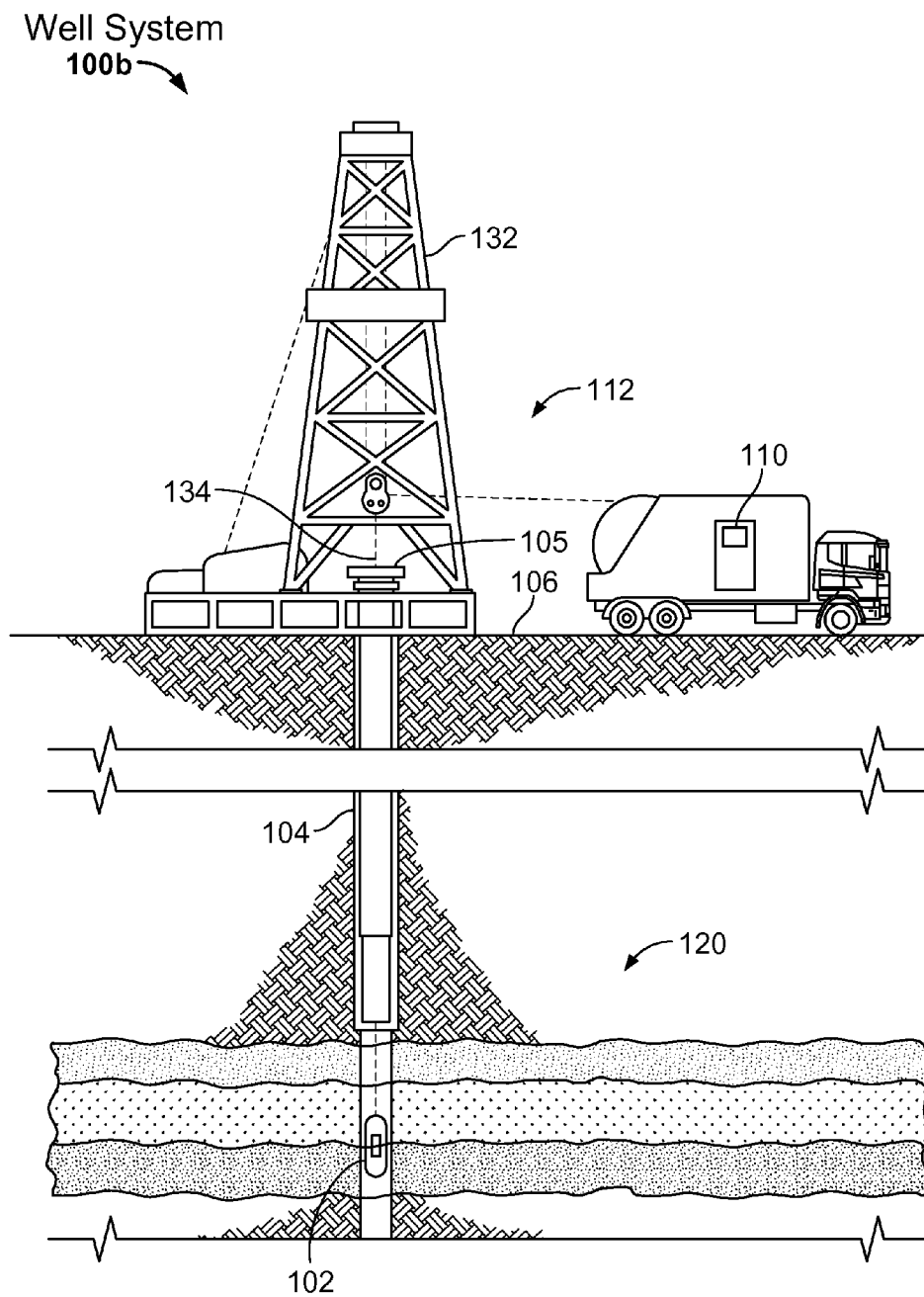

FIG. 1B

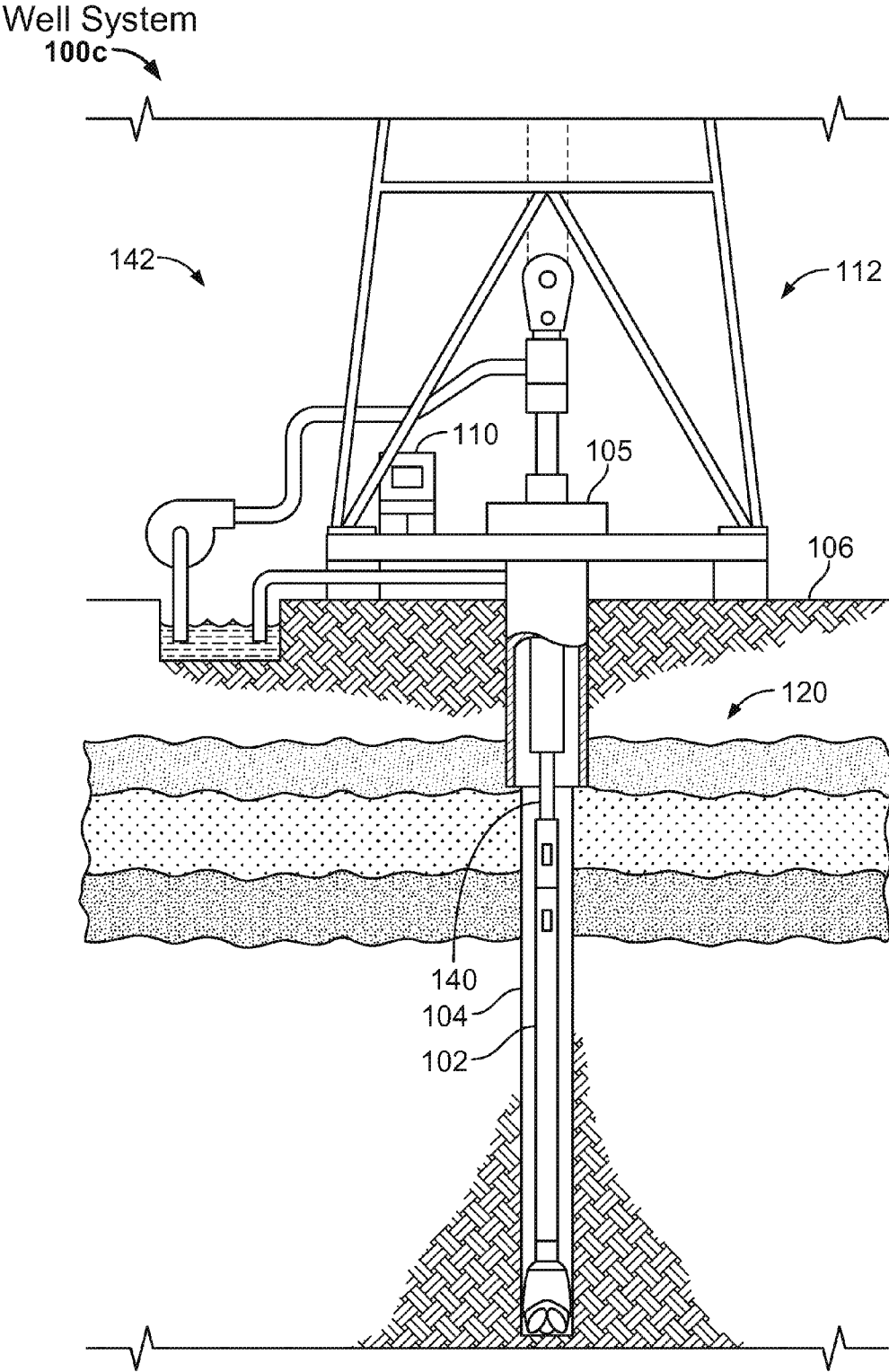
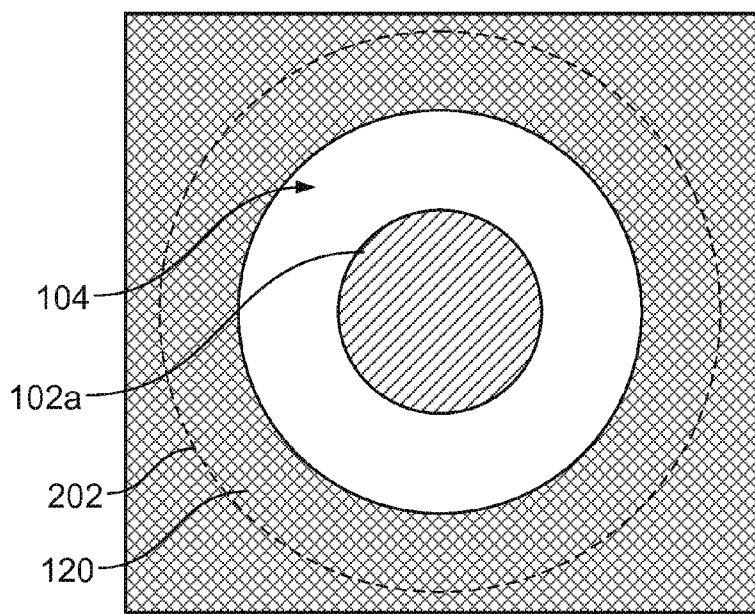
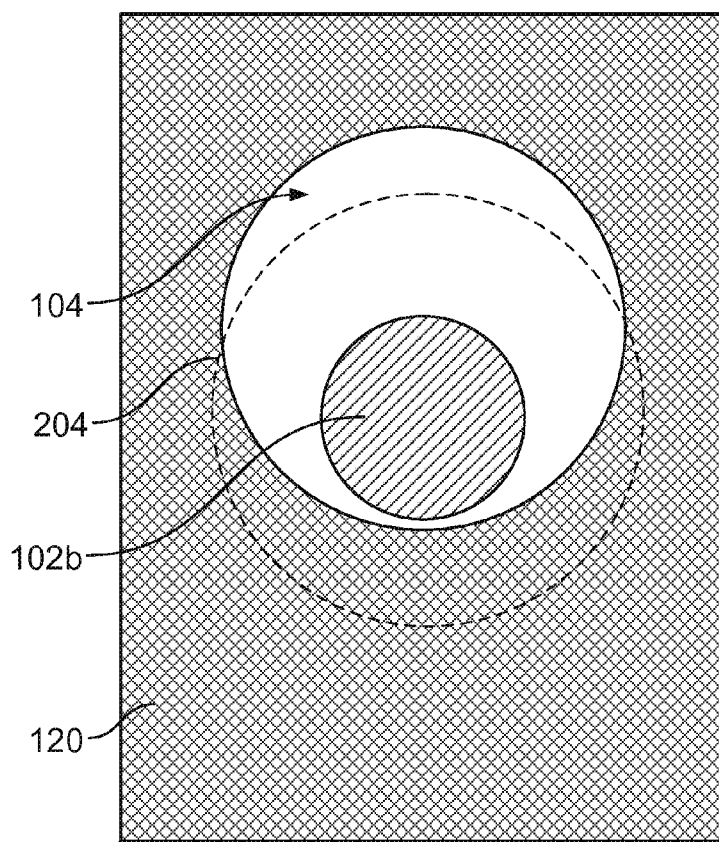

FIG. 1C



Concentric

FIG. 2A



Eccentric

FIG. 2B

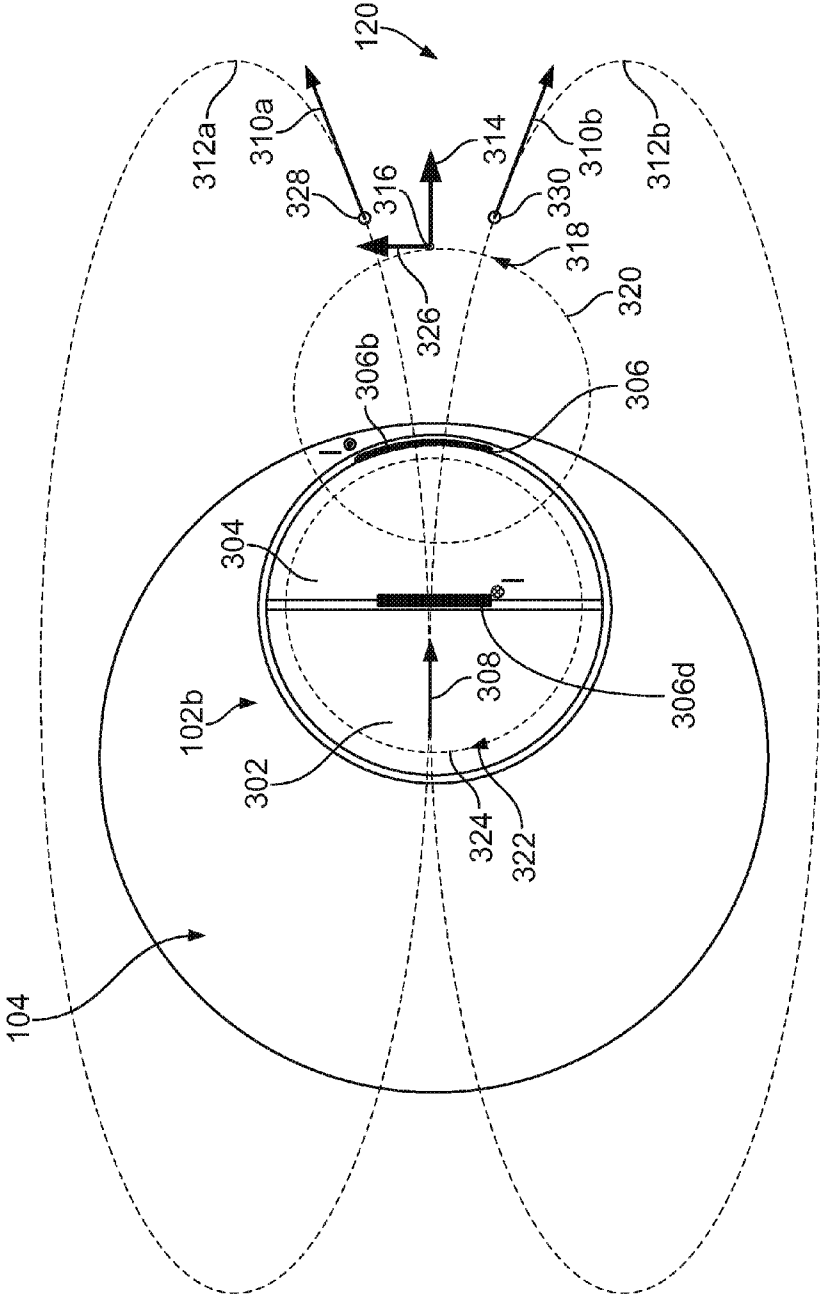

FIG. 3

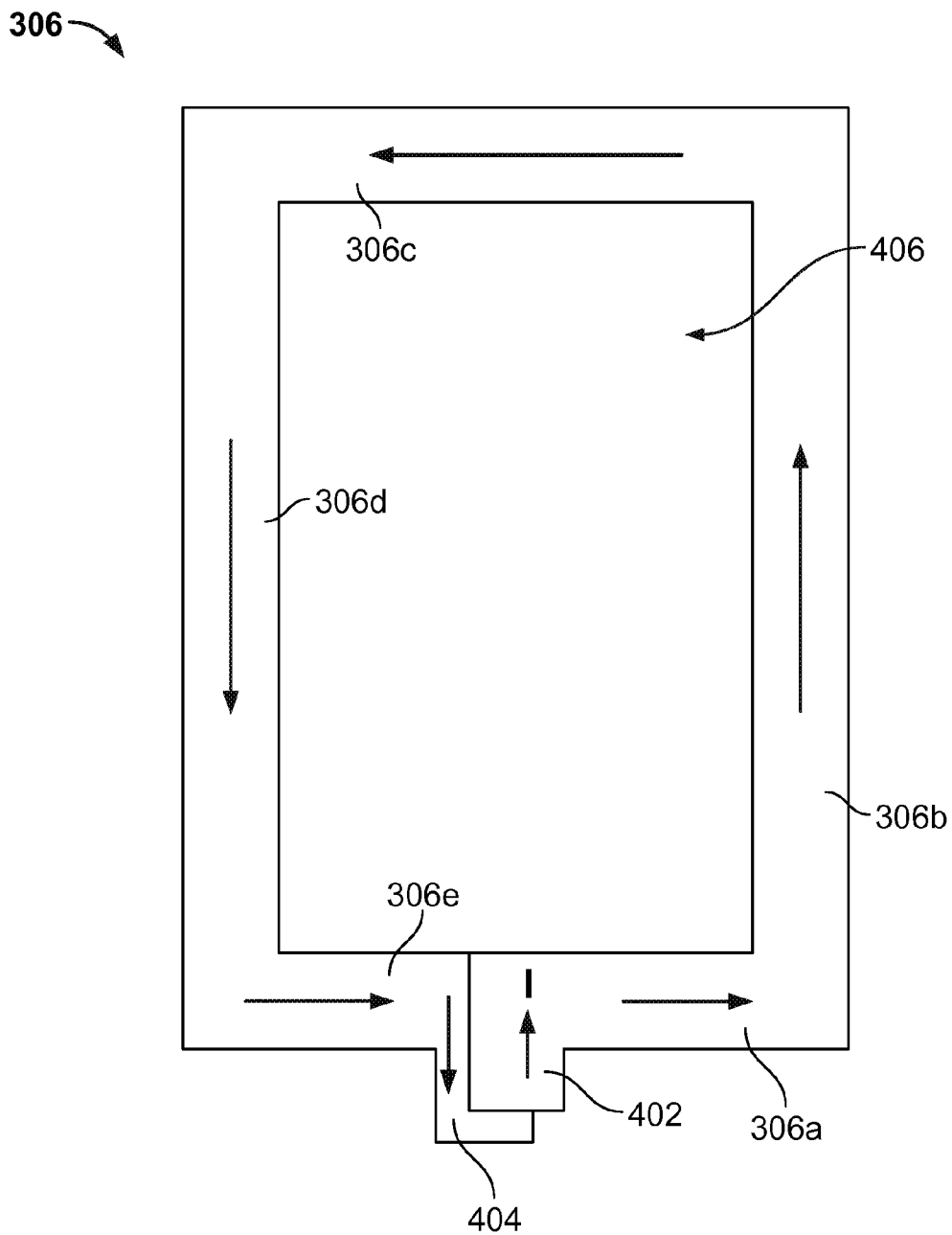

FIG. 4

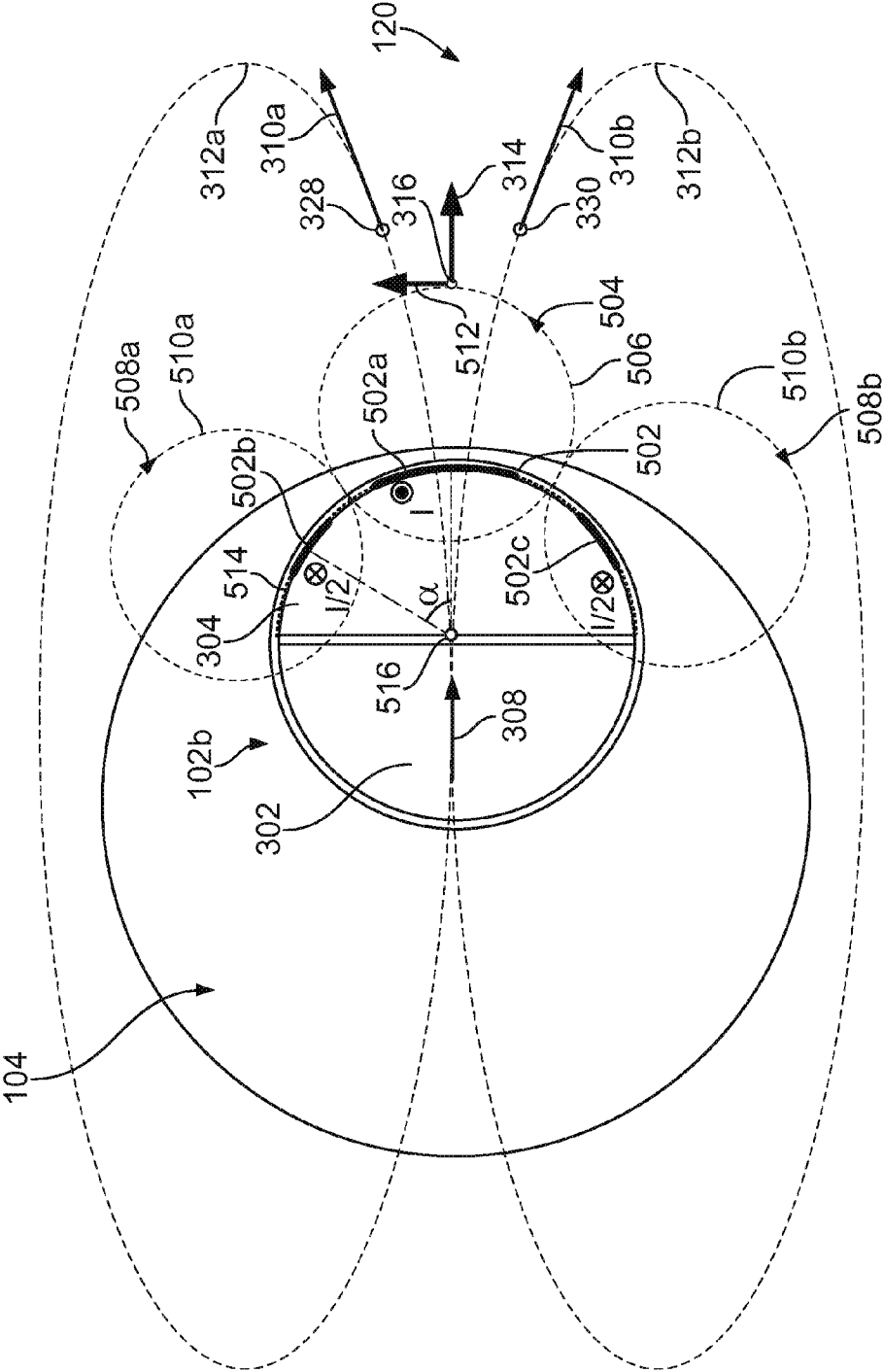

FIG. 5

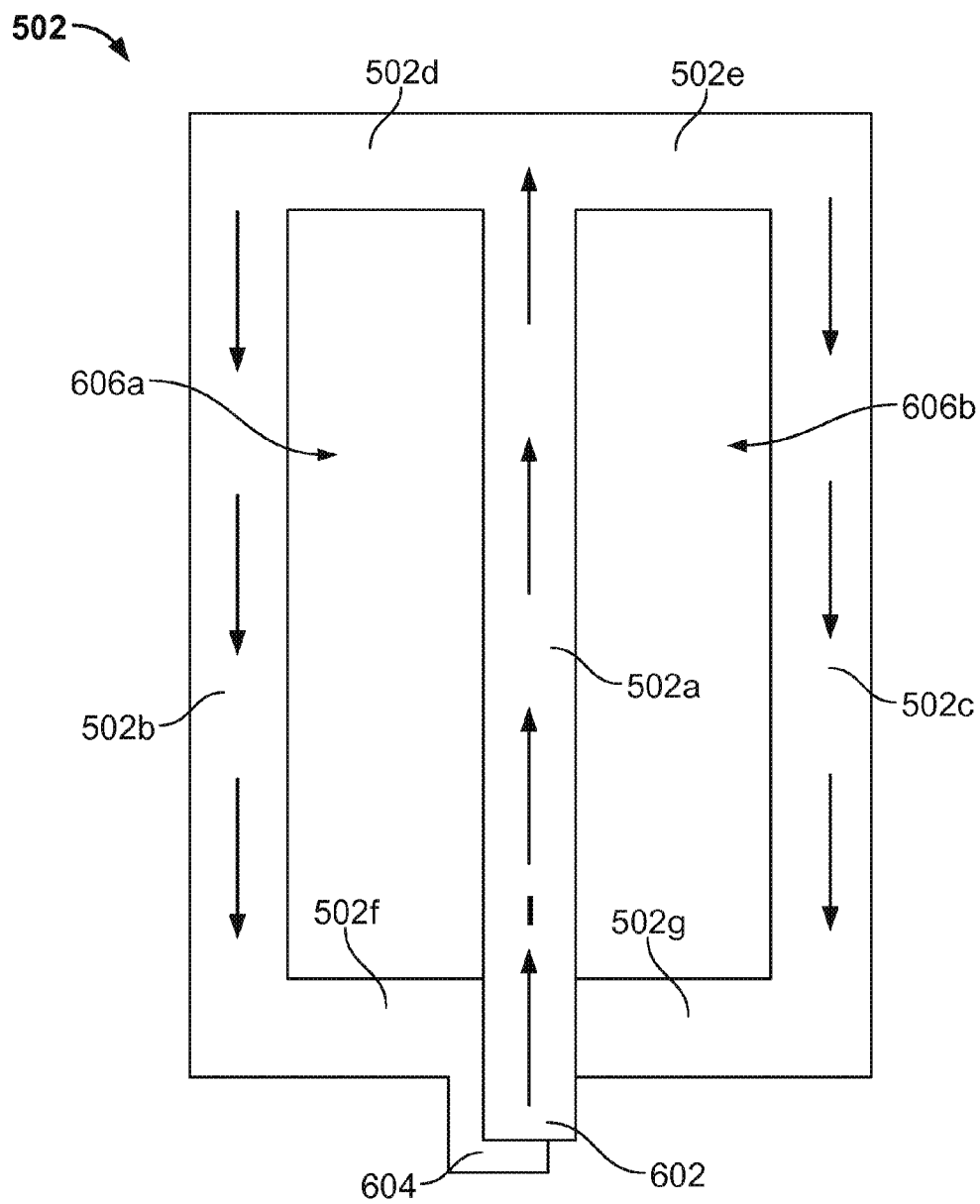

FIG. 6

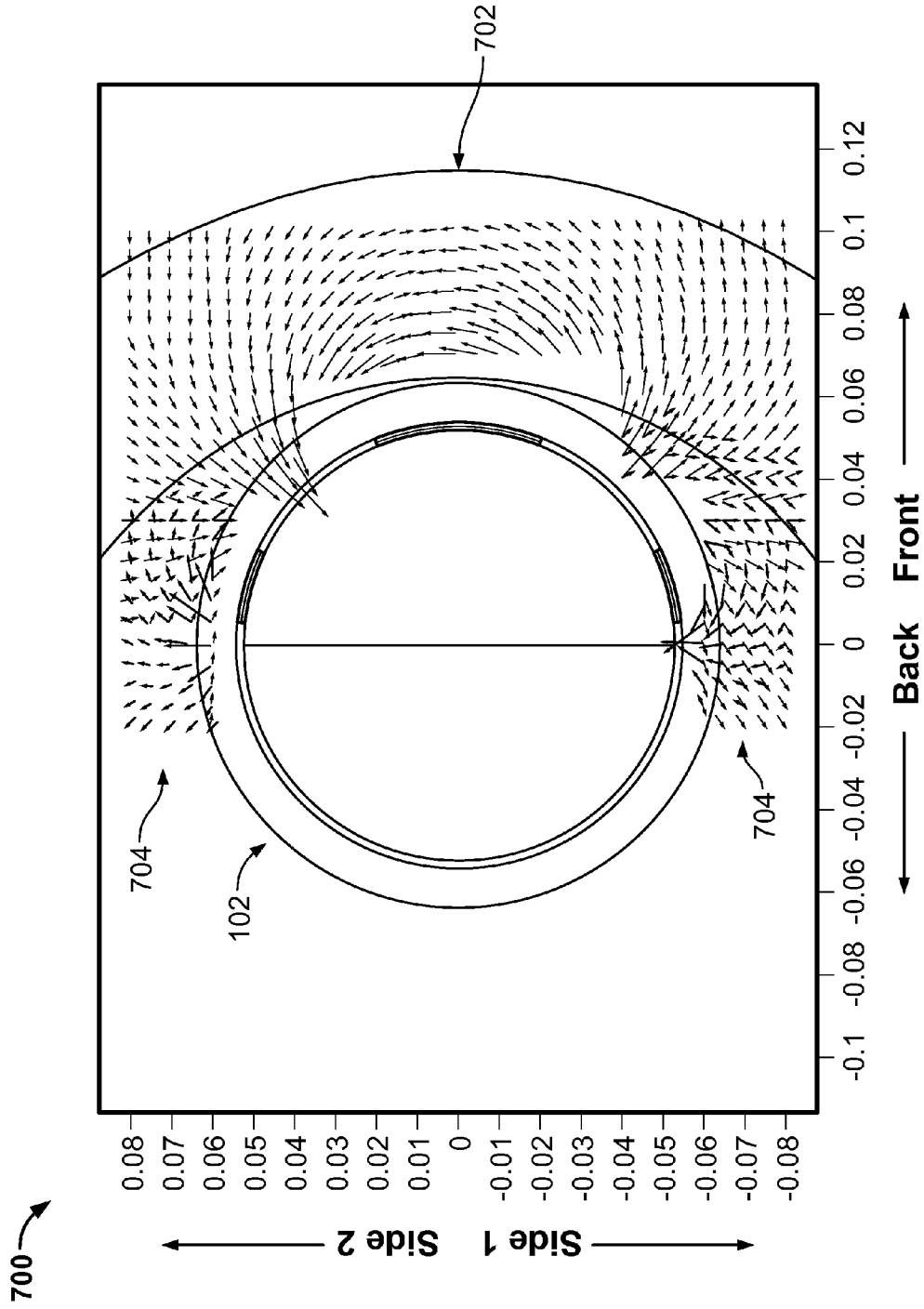

FIG. 7

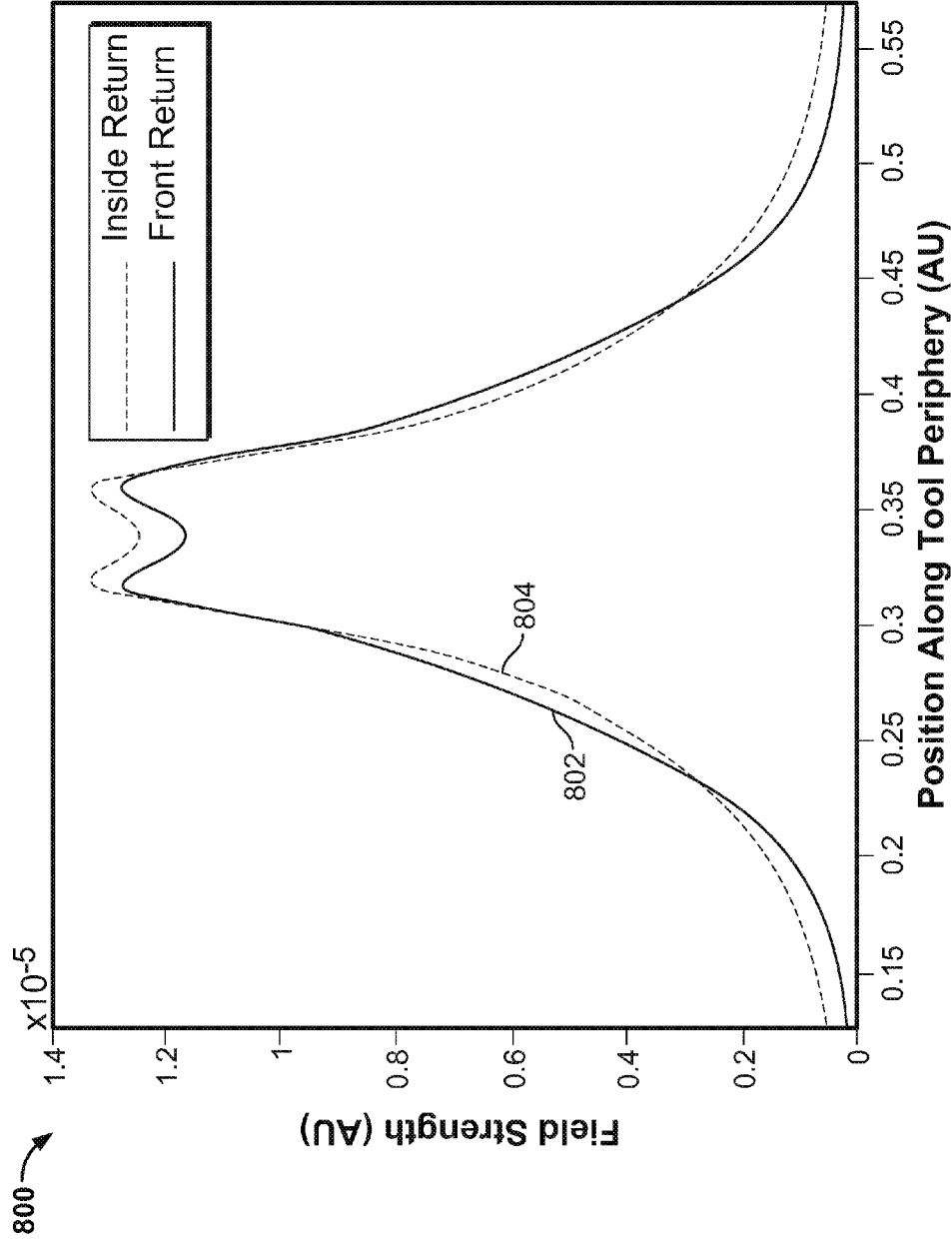

FIG. 8
Arc Length 0 = Back of Tool (Circumference approximately 0.68)

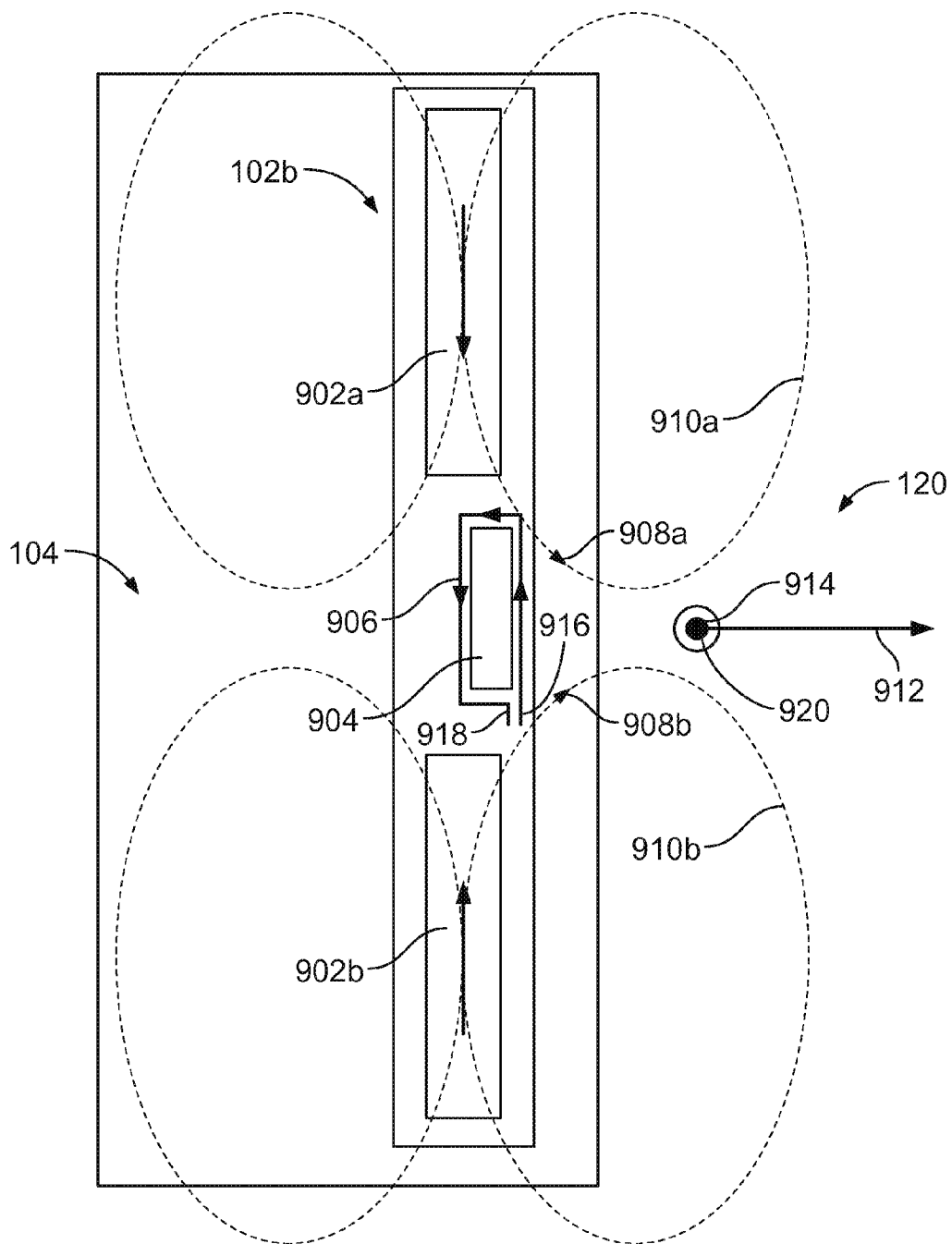

FIG. 9

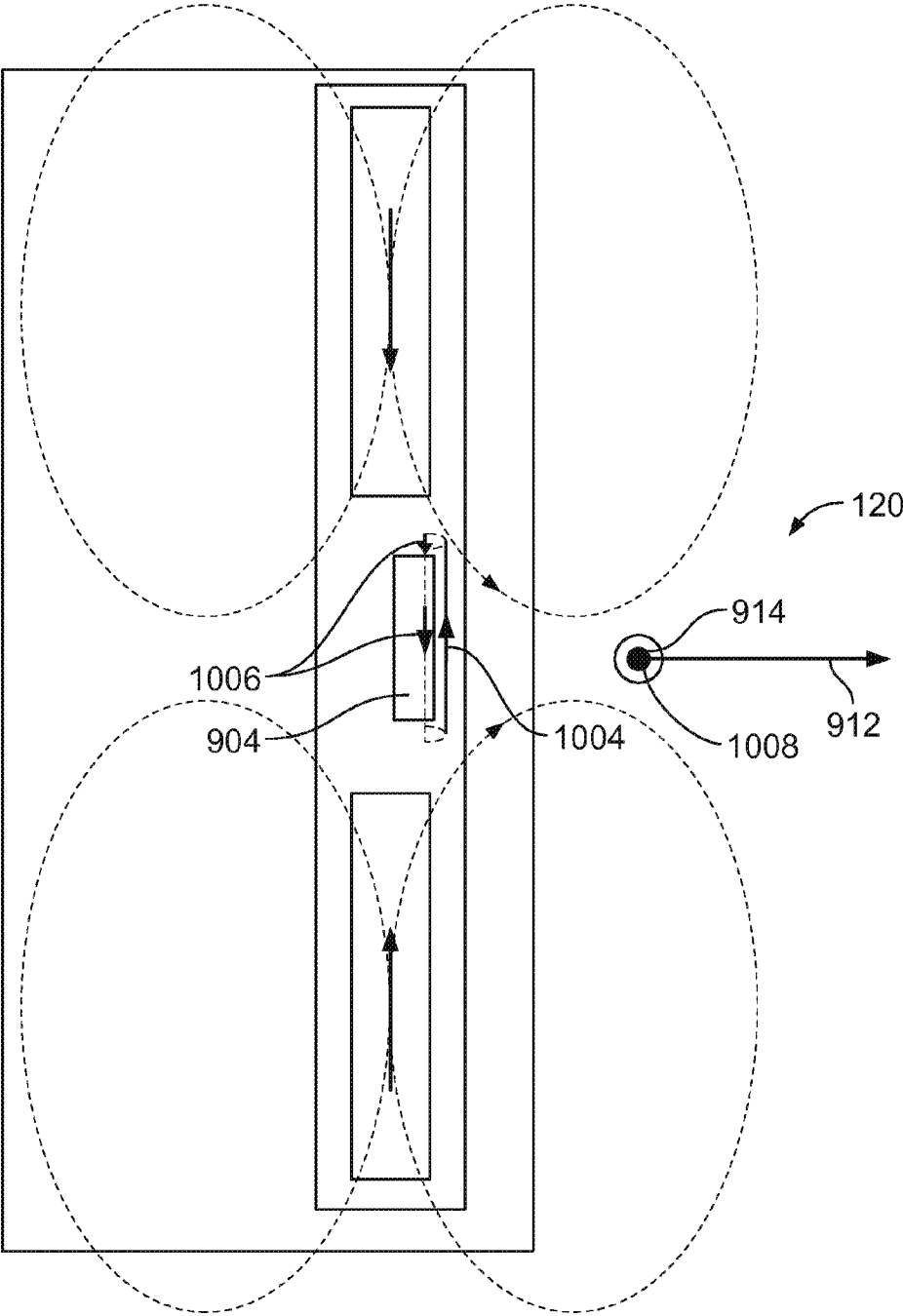

FIG. 10

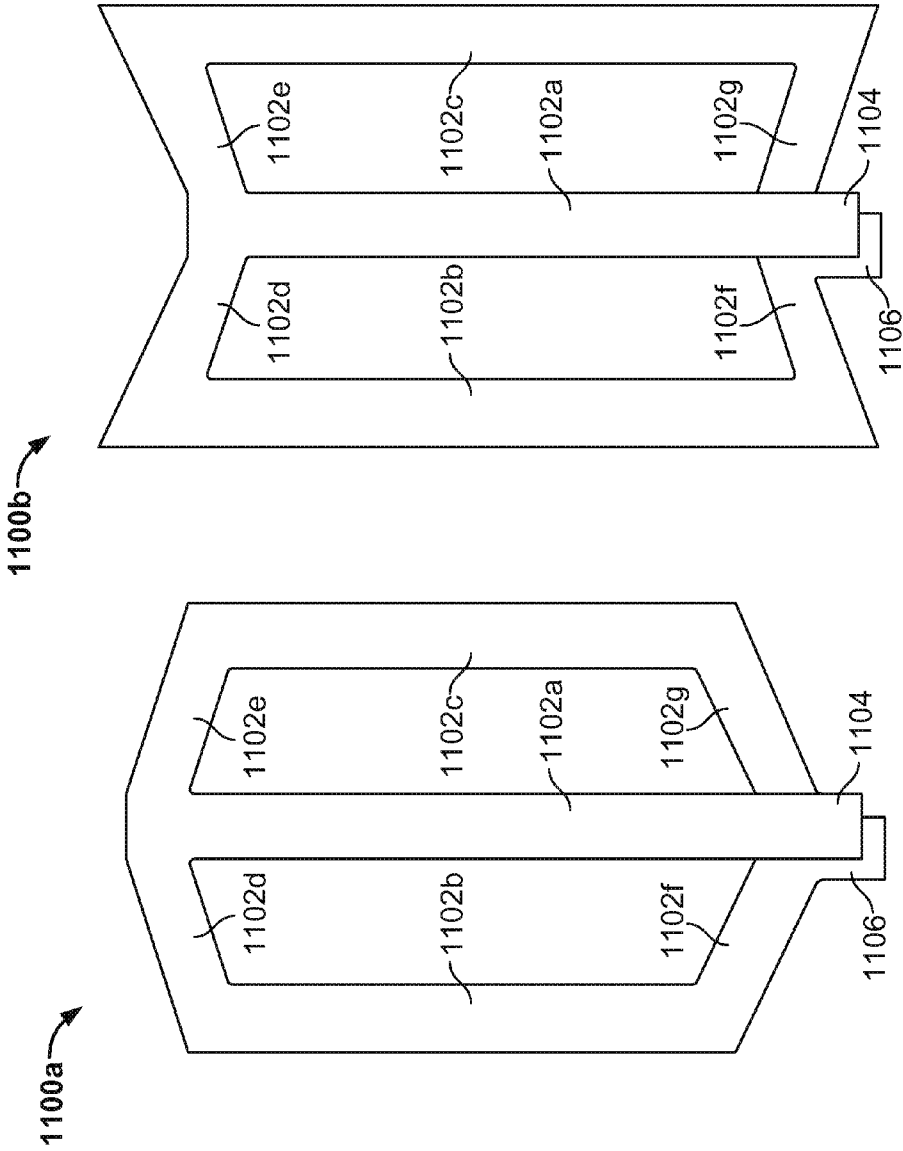

FIG. 11B

FIG. 11A

**FRONT TANGENTIAL ANTENNA FOR
NUCLEAR MAGNETIC RESONANCE (NMR)
WELL LOGGING**

TECHNICAL FIELD

[0001] This disclosure relates to nuclear magnetic resonance (NMR), and more particularly to NMR well logging systems having a front tangential antenna used to analyze subterranean environments.

BACKGROUND

[0002] In the field of logging (e.g., wireline logging, logging while drilling (LWD) and measurement while drilling (MWD)), nuclear magnetic resonance (NMR) tools have been used to explore the subsurface based on magnetic interactions with subsurface material. Some downhole NMR logging tools include a magnet assembly that produces a static magnetic field, and an antenna assembly that generates radio-frequency (RF) controlled signals and detects magnetic resonance phenomena in the subsurface material. Properties of the subsurface material can be identified from the detected phenomena.

DESCRIPTION OF DRAWINGS

- [0003]** FIG. 1A is a diagram of an example well system.
[0004] FIG. 1B is a diagram of an example well system that includes an NMR logging tool in a wireline logging environment.
[0005] FIG. 1C is a diagram of an example well system that includes an NMR logging tool in a logging while drilling (LWD) environment.
[0006] FIGS. 2A-B are diagrams of example concentric and eccentric well logging systems.
[0007] FIG. 3 is a diagram of an example logging tool positioned within a wellbore.
[0008] FIG. 4 is a diagram of an example antenna.
[0009] FIG. 5 is a diagram of another example logging tool positioned within a wellbore.
[0010] FIG. 6 is a diagram of another example antenna.
[0011] FIG. 7 is a plot of magnetic field strength induced by an example logging tool having a front return arrangement.
[0012] FIG. 8 is a plot comparing magnetic field strength induced by example logging tools having an inside return arrangement and a front return arrangement.
[0013] FIG. 9 is a diagram of another example logging tool positioned within a wellbore.
[0014] FIG. 10 is a diagram of another example logging tool positioned within a wellbore.
[0015] FIGS. 11A-B are diagrams of other example antennas.
[0016] Like reference symbols in the various drawings indicate like elements.

DETAILED DESCRIPTION

- [0017]** FIG. 1A is a diagram of an example well system **100a**. The example well system **100a** includes an NMR logging system **108** and a subterranean region **120** beneath the ground surface **106**. A well system can include additional or different features that are not shown in FIG. 1A. For example, the well system **100a** may include additional drilling system components, wireline logging system components, etc.
[0018] The subterranean region **120** can include all or part of one or more subterranean formations or zones. The

example subterranean region **120** shown in FIG. 1A includes multiple subsurface layers **122** and a wellbore **104** penetrated through the subsurface layers **122**. The subsurface layers **122** can include sedimentary layers, rock layers, sand layers, or combinations of these other types of subsurface layers. One or more of the subsurface layers can contain fluids, such as brine, oil, gas, etc. Although the example wellbore **104** shown in FIG. 1A is a vertical wellbore, the NMR logging system **108** can be implemented in other wellbore orientations. For example, the NMR logging system **108** may be adapted for horizontal wellbores, slant wellbores, curved wellbores, vertical wellbores, or combinations of these.

[0019] The example NMR logging system **108** includes a logging tool **102**, surface equipment **112**, and a computing subsystem **110**. In the example shown in FIG. 1A, the logging tool **102** is a downhole logging tool that operates while disposed in the wellbore **104**. The example surface equipment **112** shown in FIG. 1A operates at or above the surface **106**, for example, near the well head **105**, to control the logging tool **102** and possibly other downhole equipment or other components of the well system **100**. The example computing subsystem **110** can receive and analyze logging data from the logging tool **102**. An NMR logging system can include additional or different features, and the features of an NMR logging system can be arranged and operated as represented in FIG. 1A or in another manner.

[0020] In some instances, all or part of the computing subsystem **110** can be implemented as a component of, or can be integrated with one or more components of, the surface equipment **112**, the logging tool **102** or both. In some cases, the computing subsystem **110** can be implemented as one or more discrete computing system structures separate from the surface equipment **112** and the logging tool **102**.

[0021] In some implementations, the computing subsystem **110** is embedded in the logging tool **102**, and the computing subsystem **110** and the logging tool **102** can operate concurrently while disposed in the wellbore **104**. For example, although the computing subsystem **110** is shown above the surface **106** in the example shown in FIG. 1A, all or part of the computing subsystem **110** may reside below the surface **106**, for example, at or near the location of the logging tool **102**.

[0022] The well system **100a** can include communication or telemetry equipment that allow communication among the computing subsystem **110**, the logging tool **102**, and other components of the NMR logging system **108**. For example, the components of the NMR logging system **108** can each include one or more transceivers or similar apparatus for wired or wireless data communication among the various components. For example, the NMR logging system **108** can include systems and apparatus for wireline telemetry, wired pipe telemetry, mud pulse telemetry, acoustic telemetry, electromagnetic telemetry, or a combination of these other types of telemetry. In some cases, the logging tool **102** receives commands, status signals, or other types of information from the computing subsystem **110** or another source. In some cases, the computing subsystem **110** receives logging data, status signals, or other types of information from the logging tool **102** or another source.

[0023] NMR logging operations can be performed in connection with various types of downhole operations at various stages in the lifetime of a well system. Structural attributes and components of the surface equipment **112** and logging tool **102** can be adapted for various types of NMR logging operations. For example, NMR logging may be performed

during drilling operations, during wireline logging operations, or in other contexts. As such, the surface equipment **112** and the logging tool **102** may include, or may operate in connection with drilling equipment, wireline logging equipment, or other equipment for other types of operations.

[0024] In some implementations, the logging tool **102** includes a magnet assembly, which may be arranged to create a static magnetic field in a volume of interest. The logging tool **102** can also include one or more antenna assemblies. The antenna assemblies can produce an excitation in a subterranean volume and acquire a response from the volume by quadrature detection.

[0025] In some examples, NMR logging operations are performed during wireline logging operations. FIG. **1B** shows an example well system **100b** that includes the NMR logging tool **102** in a wireline logging environment. In some example wireline logging operations, surface equipment **112** includes a platform above the surface **106**. The platform of surface equipment **112** is equipped with a derrick **132** that supports a wireline cable **134** that extends into the wellbore **104**. Wireline logging operations can be performed, for example, after a drilling string is removed from the wellbore **104**, to allow the wireline logging tool **102** to be lowered by wireline or logging cable into the wellbore **104**.

[0026] In some examples, NMR logging operations are performed during drilling operations. FIG. **1C** shows an example well system **100c** that includes the NMR logging tool **102** in a logging while drilling (LWD) environment. Drilling is commonly carried out using a string of drill pipes connected together to form a drill string **140** that is lowered through a rotary table into the wellbore **104**. In some cases, a drilling rig **142** at the surface **106** supports the drill string **140**, as the drill string **140** is operated to drill a wellbore penetrating the subterranean region **120**. The drill string **140** may include, for example, a kelly, drill pipe, a bottom hole assembly, and other components. The bottom hole assembly on the drill string may include drill collars, drill bits, the logging tool **102**, and other components. The logging tools may include measuring while drilling (MWD) tools, LWD tools, and others.

[0027] In some example implementations, the logging tool **102** includes an NMR tool for obtaining NMR measurements from the subterranean region **120**. As shown, for example, in FIG. **1B**, the logging tool **102** can be suspended in the wellbore **104** by a coiled tubing, wireline cable, or another structure that connects the tool to a surface control unit or other components of the surface equipment **112**. In some example implementations, the logging tool **102** is lowered to the bottom of a region of interest and subsequently pulled upward (e.g., at a substantially constant speed) through the region of interest. As shown, for example, in FIG. **1C**, the logging tool **102** can be deployed in the wellbore **104** on jointed drill pipe, hard wired drill pipe, or other deployment hardware. In some example implementations, the logging tool **102** collects data during drilling operations as it moves downward through the region of interest during drilling operations. In some example implementations, the logging tool **102** collects data while the drilling string **140** is moving, for example, while it is being tripped in or tripped out of the wellbore **104**.

[0028] In some example implementations, the logging tool **102** collects data at discrete logging points in the wellbore **104**. For example, the logging tool **102** can move upward or downward incrementally to each logging point at a series of depths in the wellbore **104**. At each logging point, instru-

ments in the logging tool **102** perform measurements on the subterranean region **120**. The measurement data can be communicated to the computing subsystem **110** for storage, processing, and analysis. Such data may be gathered and analyzed during drilling operations (e.g., during logging while drilling (LWD) operations), during wireline logging operations, or during other types of activities. In some implementations, measurement data can be stored by logging tool **102** (e.g., in a data storage module) for future retrieval and analysis, for example after logging tool **102** is removed from the wellbore **104**.

[0029] The computing subsystem **110** can receive and analyze the measurement data from the logging tool **102** to detect properties of various subsurface layers **122**. For example, the computing subsystem **110** can identify the density, material content, or other properties of the subsurface layers **122** based on the NMR measurements acquired by the logging tool **102** in the wellbore **104**.

[0030] In an example downhole NMR experiment, a static magnetic field, B_0 , and second radio frequency (RF) magnetic field, B_1 , are used to create and manipulate nuclear magnetization. NMR experiments can give insight to a variety of properties of the downhole environment, for example diffusion, viscosity, porosity (i.e., amount of fluid in an underground formation), and permeability, among others. These properties can be measured from the NMR response, which measures the T_1 recovery time, T_2 decay time, and T_{rho} relaxation time of the magnetization.

[0031] Well logging is often classified into two categories: concentric and eccentric. Concentric well logging (also referred to as “centralized” well logging) can be used to omnidirectionally analyze the environment surrounding a logging tool. For example, FIG. **2A** depicts an axial cross-section of an axially-extending concentric logging tool **102a**. Logging tool **102a** is positioned within a wellbore **104**, such that the axis of extension of logging tool **102** is approximately parallel to the extension of the wellbore **104**. In concentric well logging, the logging tool **102a** can be positioned centrally within the wellbore **104**, and can omnidirectionally analyze the subterranean region **120** that surrounds the logging tool **102a**. As an example, logging tool **102a** can be used to analyze the portion enclosed by dotted line **202**.

[0032] In contrast, eccentric well logging (also referred to as “side-looking” well logging) can be used to analyze a directionally-dependent portion of the environment surrounding a logging tool. For example, FIG. **2B** depicts an axial cross-section of an axially-extending eccentric logging tool **102b**. Logging tool **102b** is also positioned within a wellbore **104**, such that the axis of extension of logging tool **102** is approximately parallel to the extension of the wellbore **104**. In eccentric well logging, a logging tool **102b** can be positioned away from the center of the wellbore **104**, such that it analyzes a directionally-dependent portion of the subterranean region **120** that surrounds the logging tool **102b**. As an example, logging tool **102b** can be used to analyze the portion enclosed by dotted line **204**. However, with the RF field decay towards the back of the tool, the majority of the signal in that region will be from the formation in front of the tool, and minimally from the mud in the borehole.

[0033] The magnet and antenna assemblies of logging tool **102** can be arranged according to different geometries to better suit concentric or eccentric well logging operations. For example, in eccentric well logging applications, a logging tool **102** can have magnet and antenna assemblies arranged

about a core of “soft” magnetically permeable material. In some implementations, this magnetically permeable material can have a relative magnetic permeability in a range from about 2 to 200 (i.e., have a permeability between 2 and 200 times that of free space). Example materials include polymer ferrite (e.g., having a relative permeability in a range from about 2 to 20), and molypermalloy powder (MPP) (e.g., having a relative permeability in a range from about 10 to 200). In some implementations, the magnetically permeable material can be a material that has a relative magnetic permeability of greater than 200. For example, in some implementations, these materials can include “soft” ferrite materials such as 3F3. A permeability of about 9 to 20 might be preferable in certain circumstances, for example to promise a compromise between magneto-acoustic ringing and magnetic permeability.

[0034] This magnetically permeable material can be positioned in a manner that decreases the magnetic flux in the proximity of the magnet due to the antenna, thus dampening eddy currents and reducing ringing artifacts from the magnet by directionally focusing the antenna’s RF field B_1 outward from the tool. An example arrangement for a logging tool and its corresponding magnetic flux is shown in FIG. 3. In the following example, the spatial relationship between the logging tool and its induced magnetic flux is exaggerated, and is not drawn to scale. FIG. 3 depicts an axial cross-section of an axially-extending eccentric logging tool **102b** positioned within a wellbore **104**, and used to directionally analyze the subterranean region **120** that surrounds the logging tool **102b**. Logging tool **102b** includes a radially arranged magnet **302**, a magnetic core **304** made of a magnetically permeable material, and tangentially arranged antenna **306**.

[0035] Magnet **302** is used to create the magnetic field B_0 in an NMR experiment. Magnet **302** has remnant field **308** that extends radially towards magnetically permeable magnetic core **304**, and induces magnetic flux, depicted in FIG. 3. This magnetic flux is depicted at particular points **328** and **330** as arrows **310a** and **310b**, respectively, positioned along dotted lines **312a** and **312b**, respectively. This magnetic flux induces magnetization, in all regions containing magnetic spin, in the direction of the magnetic field. For example, the point **316** within the subterranean region **120** has magnetization in the direction of arrow **314**. This magnetization is proportional to the static field, B_0 , and is relatively small.

[0036] In some implementations, the magnet **302** is a permanent magnet (e.g., Samarium cobalt, Alnico, ferrite, or other rare earth magnets). In other implementations, the magnet **302** is an electromagnet (e.g., a solenoid composed of materials such as copper, silver, and gold). Magnet **302** can induce magnetic fields of varying strengths. For example, in some implementations, at the zone of interest, the strength of the induced magnetic field can be approximately 0.0025 Tesla to 1.5 Tesla. Magnet **302** may be of various shapes. In this example configuration, magnet **302** is generally a half cylinder with a semi-circular axial cross section. In cross section, magnet **302** is defined by an outer semicircular arc faces outward from the logging **102b**, and an inner edge that faces magnetic core **304**. In some implementations, magnet **302** may be of other shapes. For instance, in some implementations, magnet **302** can have a cross section that includes rectangular, square, circular, elliptical, polygonal, or irregular elements. In some implementations, operation of the magnet

302 can be controlled by an electronic controller module, for example an electronic processor in computing subsystem **110**.

[0037] Magnetic core **304** is made of a magnetically permeable material. For example, in some implementations, magnetic core **304** is made of (ferrotron, ferrite, Molypermalloy, or other permeable magnetic materials). Magnetic core **304** can be made of materials that vary in relative permeability. For example, in some implementations, magnetic core **304** can be made of permeable magnetic materials with relative permeability greater than 5. Magnetic core **304** may be of various shapes. In this example configuration, magnetic core **304** has a generally semi-circular axial cross section, and is generally symmetrical with magnet **302**. In cross section, magnetic core **304** is defined by an outer semicircular arc faces outward from the logging **102b**, and an inner edge that faces magnet **302**. In some implementations, magnetic core **304** may be of other shapes. For instance, in some implementations, magnet **302** can have a cross section that includes rectangular, square, circular, elliptical, polygonal, or irregular elements. In some implementations, magnetic core **304** is not symmetrical to magnet **302**, and may have a different shape or volume.

[0038] Antenna **306** is a path of electrically conductive material positioned along magnetic core **304**. For example, in some implementations, antenna **306** can be made of electrically conductive metals, such as copper, aluminum, gold, silver, or high temperature super conductors. Antenna **306** carries a current I in order to induce an RF magnetic field B_1 in an NMR experiment, and is used to measure the NMR signal in response to the induced fields. In some implementations, this applied current can be controlled by an electronic controller module, for example an electronic processor in computing subsystem **110**. Antenna **306** can be of various shapes. For instance, in some implementations, antenna **306** can define a loop. An example antenna **306** is shown in FIG. 3, illustrating a cross-sectional view of the antenna **306** positioned within logging tool **102b**, and FIG. 4, illustrating a flattened view of antenna **306**. Antenna **306** can include an input lead **402**, where a current I can be applied to the antenna **306**, and an output lead **404**, where the current I can flow out of the antenna **306**. Between the input and output leads, antenna **306** defines a conductive path. For example, antenna **306** can include a first segment **306a** that extends radially from input lead **402**, a second segment **306b** that extends parallel to the axis of tool **102b** along the outward-facing edge of magnetic core **304**, a third segment **306c** that extends radially, a fourth segment **306d** that extends parallel to the axis of tool **102b** along an inward-facing edge of magnetic core **304**, and a fifth segments **306e** that connects to the output lead **404**, forming a loop **406**. In some implementations, antenna **306** can be positioned on magnetic core **304** such that it directly contacts magnetic core **304**. For example, antenna **306** can be secured directly onto magnetic core **304** using an adhesive material or securing element (e.g., a bracket, clip, pin, or other suitable securing element). In some implementations, antenna **306** may be positioned slightly distant from magnetic core **304**, such that it does not directly contact magnetic core **304**. For example, antenna **306** and magnetic core **304** can be separated by a layer of relatively non-conductive material (e.g., a layer of adhesive material such as glue), a holder or bracket made of a relatively non-conductive material (e.g., a holder made out of a plastic or polymer, such as polyether ether ketone (PEEK)), or air.

[0039] Referring back to FIG. 3, when a current I is applied to antenna 306 at input lead 402, current I flows outward from input lead 402 in a first direction (depicted in FIG. 3 as flowing out of the page) along segment 306*b*, inducing magnetic flux (depicted as arrowhead 318 positioned along dotted line 320). Current I also returns to output lead 402 by flowing in a second direction (depicted in FIG. 3 as flowing into the page) along segment 306*d*, inducing magnetic flux (depicted as arrowhead 322 positioned along dotted line 324). At point 316, the net RF magnetic flux induced by the current I in the antenna points tangentially to the tool (represented by arrow 326), and is perpendicular to the net magnetic field B_0 induced by the magnet (represented by arrow 314). The RF magnetic field induced by the antenna is called B_1 in an NMR experiment.

[0040] In a similar manner, antenna 306 can be used to detect changes in magnetism, such as nuclear magnetization, in the surrounding environment. For instance, in an example NMR experiment, nuclear magnetization at point 316 is allowed to polarize such that it initially aligns with the B_0 field, is tipped around the B_1 field, and relaxes back towards the B_0 field when the B_1 field is removed. Antenna 306 can be used to measure the nuclear magnetization precession through electromagnetic induction, and can be used to produce electric signals in response to the changing nuclear magnetism.

[0041] In this example configuration, the “outward path” of antenna 306 (i.e., the segment 306*a* that directs current I outward from input lead 402) is positioned along a surface of magnetic core 304 opposite from magnet 302, while the “return path” of the antenna 306 (i.e., segment 306*d* that returns current I back to the output lead 404) is positioned along a surface of magnetic core 304 that faces towards magnet 302. This configuration is known as an “inside return.”

[0042] While antenna 306 is described as having a single loop wrapped around magnetic core 304, antennas can define paths of different shapes, and can be arranged differently with respect to magnetic core 304. For example, referring to FIG. 5 and FIG. 6, in some implementations, a logging tool 102*b* includes a radially-arranged magnet 302, a magnetic core 304 made of a magnetically permeable material, and tangentially arranged antenna 502.

[0043] As before, magnet 302 can be used to induce the magnetic field B_0 in an NMR experiment. Magnet 302 has a remnant field 308 that extends radially towards magnetically permeable magnetic core 304, and creates lines of magnetic flux, partially depicted in FIG. 5 as arrows 310*a* and 310*b* extending from points 328 and 330, respectively, positioned along dotted lines 312*a* and 312*b*, respectively. As before, magnetic flux results in a net magnetization, in all regions with magnetic spin, in the direction of the magnetic field. For example, the point 316 within the subterranean region 120 has magnetization in the direction of arrow 314.

[0044] Antenna 502 is a path of electrically conductive material positioned along magnetic core 304. As with antenna 306, antenna 502 carries a current I in order to induce an RF magnetic field B_1 in an NMR experiment, and is used to measure the NMR signal in response to the fluctuating nuclear magnetization. In some implementations, antenna 502 can define multiple loops. An example antenna 502 is shown in FIG. 5, illustrating a cross-sectional view of the antenna 502 positioned within logging tool 102*b*, and FIG. 6, illustrating a flattened view of antenna 502. Antenna 502 can include an input lead 602, where a current I can be applied to

the antenna 502, and an output lead 604, where the current I can flow out of the antenna 502. Between the input and output leads, antenna 502 defines a conductive path. For example, antenna 502 can include a common segment 502*a* that extends parallel to the axis of tool 102*b* from input lead 604, two segments 502*b-c* that extend parallel to common segment 502*a* on each side of common segment 502*a*, two segments 502*d-e* that connect common segment 502*a* to segments 502*b-c*, respectively, and two segments 502*f-g* that connect segments 502*d-e*, respectively, to output lead 604. These segments 502*a-g* form two symmetric loops 606*a* and 606*b*. As with antenna 306, in some implementations, antenna 502 can be positioned on magnetic core 304 such that it directly contacts magnetic core 304. For example, antenna 502 can be secured directly onto magnetic core 304 using an adhesive material or securing element (e.g., a bracket, clip, pin, or other suitable securing element). In some implementations, antenna 502 may be positioned slightly distant from magnetic core 304, such that it does not directly contact magnetic core 304. For example, antenna 306 and magnetic core 304 can be separated by a layer of relatively non-conductive material (e.g., a layer of adhesive material such as glue), a holder or bracket made of a relatively non-conductive material (e.g., a holder made out of a plastic or polymer, such as polyether ether ketone (PEEK)), or air.

[0045] In this example configuration, antenna 502 is positioned on a notional arc 514 defined by the outer semi-circular periphery of magnetic core 304. The common segment 502*a* extends axially from the center of the arc 514. For example, in FIG. 5, segment 502*a* extend from the center of the arc 514 in a direction parallel to the axis of tool 102*b* (i.e., into the page and out from the page). Segments 502*b-c* extend axially from the arc 514 from positions distant from common segment 502*a*. For example, in FIG. 5, segments 502*b-c* each extend from arc 514 in a direction parallel to the axis of tool 102*b* (i.e., into the page and out from the page). In this example, segments 502*b-c* are separated from the common segment 502*a* by an angular distance α . Angular distance α can differ, depending on the implementation. For example, in some implementations, angular distance α can be approximately 80 to 85 degrees relative to the focus 516 of the arc 514. In some implementations, segments 502*b-c* can be separated by common segment 502*a* by other angular distances. For example, in some implementations, angular distance α can be approximately 20 to 120 degrees. The angular distances α between segments 502*b-c* and common segment 502*a* can also vary based on the angular distance covered by the segments 502*a-c* themselves. For example, in some implementations, the angular distances α can vary depending on the thickness of segments 502*a-c*.

[0046] Referring back to FIG. 5, when a current I is applied to antenna 502 at input lead 602, current I flows outward from input lead 602 in a first direction (depicted in FIG. 5 as flowing out of the page) along common segment 502*a*, inducing magnetic flux (depicted as arrowhead 504 positioned along dotted line 506). Current I also returns to output lead 604 by flowing in a second direction (depicted in FIG. 5 as flowing into the page) along segments 502*b-c*, with the current I divided between the two segments 502*b-c*. This current $I/2$ in each segment 502*b-c* induces magnetic flux (depicted as arrowheads 508*a* and 508*b* positioned along dotted lines 510*a* and 510*b*, respectively), the magnetic field of the antenna being known as B_1 . At point 316, the net RF magnetic flux induced by the current I in the antenna points tangentially

to the tool (represented by arrow **512**), and is perpendicular to the net magnetic field B_0 induced by the magnet (represented by arrow **314**). In a similar manner, antenna **602** can also be used to detect changes in magnetism in the surrounding environment. For instance, in an example NMR experiment, nuclear magnetization at point **316** is allowed time to polarize such that it initially aligns with the B_0 field, then is tipped around the B_1 field, and when the B_1 field is removed, relaxes back towards the B_0 field. Antenna **502** can be used to measure the NMR precession through electromagnetic induction by producing electric signals in response to the changing nuclear magnetism. As above, the spatial relationship between the logging tool and its induced magnetic flux is exaggerated, and is not drawn to scale.

[0047] In this example configuration, the “outward path” of antenna **502** (i.e., the common segment **502a** that directs current I outward from input lead **602**) is positioned along a surface of magnetic core **304** that faces away from magnet **302**, and the “return path” of the antenna **502** (i.e., the segments **502b-c** that return current I back to the output lead **604**) is also positioned along a surface that faces away from magnet **302**. This configuration is known as a “front return.”

[0048] In some cases, a tool with a front return antenna arrangement can provide various benefits over a tool with an inside return antenna arrangement. For example, in some implementations, a logging tool **102b** having a front return antenna arrangement can be easier to manufacture and service. As an example, in some implementations, antenna **502** is located along the outer periphery of magnetic core **304** and along the outer periphery of logging tool **102b**. Thus, antenna **502** can be positioned after magnet **302** and magnetic core **304** have already been installed within logging tool **102b**. Similarly, in some implementations, antenna **502** can be removed and/or replaced without requiring the removal of magnet **302** or magnetic core **304**, making it easier to service or replace antenna **502**.

[0049] In some implementations, a tool with a front return antenna arrangement may induce an RF magnetic field (i.e., a B_1 magnetic field) that may be more beneficial for eccentric logging applications. For example, referring to FIG. 7, a plot **700** of the RF magnetic field induced by an example logging tool with a front return antenna arrangement shows that the magnetic field is relatively strong towards the front of tool **102b** (illustrated as having longer field lines **702** towards the front region), while the B_1 magnetic field is relatively weaker towards the back and the sides of the tool **102b** (illustrated as having shorter field lines towards the back and sides). This induced field strength can be compared to that induced by a tool with an inside return antenna arrangement. For example, FIG. 8 includes a plot **800** that shows the strength of RF magnetic fields induced by a tool having a front return antenna arrangement (line **802**) and a tool having an inside return antenna arrangement (line **804**) for an example antenna current of one amp. Plot **800** shows that a tool having a front return antenna arrangement induces a weaker magnetic field to the rear of the tool, compared to that induced by a tool having an inside return antenna arrangement. This can be beneficial in certain cases. In an example, if a logging tool **102b** is an eccentric logging tool, the region to the rear of the tool may be of lesser interest to the operator than the region to the front of the tool. Thus, a front return antenna arrangement can be used to preferentially analyze volumes to the front of a logging tool. In another example, if logging tool is positioned within a borehole during MWD or LWD operations,

the region to the rear of a logging tool may include fluids being pumped from the surface. In some implementations, the composition of these fluids may already been known, and there may be little value in analyzing these fluids. Further, in some implementations, these fluids may be salty, and may cause eddy currents that can introduce noise and artifacts to the NMR analysis. By reducing the B_1 magnetic field that is induced in these regions, the noise can be reduced and the signal to noise ratio (SNR) of the NMR measurements can be increased.

[0050] Thus, in some implementations, a front return antenna arrangement can be used to provide a preferred measurement direction by inducing a stronger RF magnetic field in a volume of interest for averaging closely to optimal (i.e., 90 degree) spin tipping, and thereby increasing the SNR of the NMR measurement. Similarly, in some implementations, a front return antenna arrangement can be used to detect NMR signals induced in a volume of interest with greater sensitivity.

[0051] A number of implementations have been described. Nevertheless, it will be understood that various modifications are possible. For example, while the above example shows how example logging tools having radially arranged magnets and tangentially arranged antennas can be modified to have a “front return” antenna arrangement, tools having other arrangements of magnets and magnetically permeable magnetic cores can also be modified to have a front return antenna arrangement. For instance, FIG. 9 shows another example logging tool that can be modified to have a front return arrangement. The original arrangement of this example logging tool and its corresponding magnetic flux is shown in FIG. 9. As before, the spatial relationship between the logging tool and its induced magnetic flux is exaggerated, and is not drawn to scale. FIG. 9 depicts a longitudinal cross-section of an axially-extending eccentric logging tool **102b** positioned within a wellbore **104**, and used to directionally analyze the subterranean region **120** that surrounds the logging tool **102b**. Logging tool **102b** has an arrangement similar to a conventional Jasper-Jackson arrangement, and includes two magnets **902a** and **902b**, a magnetic core **904** made of a magnetically permeable material, and an antenna **906**.

[0052] Magnets **902a-b** can be used to induce the magnetic field B_0 in an NMR experiment. Magnets **902a-b** have remnant fields **906a-b**, respectively, that extend longitudinally towards magnetically permeable core **904**, and induces magnetic flux, depicted in FIG. 9 as arrowheads **908a** and **908b** positioned along dotted lines **910a** and **910b**, respectively. This magnetic flux and magnetic field at a point **914** point with direction **912** within the subterranean region **120**. The magnetic field, B_0 , can be used in an NMR experiment.

[0053] Antenna **906** is a path of electrically conductive material wrapped around magnetic core **904**. Antenna **906** carries a current I in order to induce an RF magnetic field B_1 in an NMR experiment, and is used to measure the NMR signal in response to the induced fields. Antenna **906** can be of various shapes. For instance, in some implementations, antenna **906** can define a loop. When a current I is applied to antenna **906** at input lead **916**, current I flows outward from input lead **402** and returns to output lead **918**, inducing magnetic flux. At point **914** within the subterranean region **120**, the net RF magnetic flux induced by the current I in the antenna points perpendicular to the extension of the tool **102b** (represented as arrow **920** pointing into the page), and is perpendicular to the net magnetic field B_0 induced by the

magnets (represented by arrow 912). This RF magnetic field induced by the antenna can be used as the magnetic field B_1 in an NMR experiment.

[0054] In this example configuration, the “outward path” of antenna 906 (i.e., the segment that directs current I outward from input lead 402) is positioned along a first surface of magnetic core 304, while the “return path” of the antenna 906 (i.e., segment that returns current I back to the output lead 918) is positioned along a surface of magnetic core 304 opposite that of the outward path. This configuration is known as an “inside return.” While current I is shown in FIG. 9 as flowing in a particular direction along antenna 906, in this configuration, the direction of current flow does not matter, and can be reversed.

[0055] In a similar manner as described above, a “front return” arrangement can be used with this example logging tool. For example, referring to FIG. 10, antenna 906 can be replaced with an antenna 1002. In some implementations, antenna 1002 may be similar to antenna 502, and may include can include multiple loops defined by a centrally positioned common segment (defining an outward path from an input lead), and two other segments (defining return paths to an output lead). When a current I is applied to antenna 1002 at its input lead, current I flows outward from input lead in a first direction 1004 along its common segment, inducing magnetic flux. Current I also returns to the output lead by flowing in a second direction 1006, with the current I divided between the two segments return segments. This current $I/2$ in each return segment induces magnetic flux. This magnetic flux, at the point 914, points in direction 1008 within the subterranean region 120. This magnetic flux is the magnetic excitation field B_1 in an NMR experiment. As above, in this example, the spatial relationship between the logging tool and its induced magnetic flux is exaggerated, and is not drawn to scale.

[0056] In this example configuration, the “outward path” of antenna 1002 (i.e., the common segment that directs current I outward from input lead) is positioned along a surface of magnetic core 304 that faces the front of the tool 102, and the “return path” of the antenna 902 (i.e., the segments that return current I back to the output lead) is also positioned along a surface that faces the front of tool 102. This configuration is known as a “front return.” In a similar manner as described above, this front return arrangement can has a directionally smoother field distribution along the sensitive volume arc of the RF magnetic field, such that a stronger magnetic field is in a volume of interest for a 90 degree tipping, and thus receives an increase the SNR of the NMR measurement.

[0057] While FIG. 6 shows a certain configuration of an antenna, in general, other configurations are also possible. For instance, referring to FIGS. 11A-B, example antennas 1100a-b may be similar to antenna 502. Antennas 1102a-b include a common segment 1102a that extends from an input lead 1104, two segments 1102b-c that extend parallel to common segment 1102a on each side of common segment 1102a, two segments 1102d-e that connect common segment 1102a to segments 1102b-c, respectively, and two segments 1102f-g that connect segments 1102d-c, respectively, to output lead 1106. These segments 1102a-g form two symmetric loops 1106a and 1106b. However, in FIG. 11A segments 1102b-c are longer than common segment 1102a. Alternatively, as shown in FIG. 11B, segments 1102b-c are shorter than common segment 1102a. Other antenna configurations can be used, for example antennas that include more loops (e.g., three, four, five, etc.), and/or antennas with different loops

arrangements (e.g., rectangular loops, trapezoidal loops, parallelogram loops, polygonal loops, irregular loops, curved loops, etc.). In some implementations, antennas can define paths with different numbers of turns (e.g., one, two three, four, five, etc.).

[0058] In some implementations, antennas can be constructed from conductors of various shapes. For example, conductors can be round wire, square wire, flat ribbon conductors, foil conductors, or Litz wire.

[0059] In some implementations, antennas can include segments that are composed of multiple conductors (e.g., multiple electrically conductive wires or traces) that each carries current in a common direction. For example, in some implementations, common segment 502a of FIG. 6, 1102a of FIG. 11A, or 1102a of FIG. 11B can be composed of multiple current-carrying conductors that each carry current in parallel. These conductors can be made of electrically conductive materials such as copper, aluminum, gold, silver, or high temperature super conductors.

[0060] The techniques and systems described above can be implemented in digital electronic circuitry, or in computer software, firmware, or hardware, including the structures disclosed in this specification and their structural equivalents, or in combinations of one or more of them. For example, computing subsystem 110 can include an electronic processor that can be used to control one or more components of well system 100 or logging tool 102. In another example, an electronic processor can be used to analyze and process measurement data obtained by logging tool 102, for instance to estimate a characteristic of subsurface layers 122 or structures of well system 100, as described above.

[0061] The term “electronic processor” encompasses all kinds of apparatus, devices, and machines for processing data, including by way of example a programmable processor, a computer, a system on a chip, or multiple ones, or combinations, of the foregoing. The apparatus can include special purpose logic circuitry, e.g., an FPGA (field programmable gate array) or an ASIC (application specific integrated circuit). The apparatus can also include, in addition to hardware, code that creates an execution environment for the computer program in question, e.g., code that constitutes processor firmware, a protocol stack, a database management system, an operating system, a cross-platform runtime environment, a virtual machine, or a combination of one or more of them. The apparatus and execution environment can realize various different computing model infrastructures, such as web services, distributed computing and grid computing infrastructures.

[0062] Processors suitable for the execution of a computer program include, by way of example, both general and special purpose microprocessors, and any one or more processors of any kind of digital computer. Generally, a processor will receive instructions and data from a read only memory or a random access memory or both. The essential elements of a computer are a processor for performing actions in accordance with instructions and one or more memory devices for storing instructions and data. Generally, a computer will also include, or be operatively coupled to receive data from or transfer data to, or both, one or more mass storage devices for storing data, e.g., magnetic, magneto optical disks, or optical disks. However, a computer need not have such devices. Moreover, a computer can be embedded in another device, e.g., a mobile telephone, a personal digital assistant (PDA), a mobile audio or video player, a game console, a Global Posi-

tioning System (GPS) receiver, or a portable storage device (e.g., a universal serial bus (USB) flash drive), to name just a few. Devices suitable for storing computer program instructions and data include all forms of non-volatile memory, media and memory devices, including by way of example semiconductor memory devices, e.g., EPROM, EEPROM, and flash memory devices; magnetic disks, e.g., internal hard disks or removable disks; magneto optical disks; and CD ROM and DVD-ROM disks. The processor and the memory can be supplemented by, or incorporated in, special purpose logic circuitry.

[0063] Various aspects of the invention are summarized as follows:

[0064] In general, in an aspect, a nuclear magnetic resonance system for well logging using an axially-extending tool includes a magnet, a core having a first surface facing the magnet and one or more other surfaces facing away from the magnet, and an antenna positioned along at least one of the one or more other surfaces. The antenna includes a first loop of electrically conductive material and a second loop of electrically conductive material. The first and second loops include a common segment extending along an axis of the axially-extending tool.

[0065] Implementations of this aspect may include one or more of the following features:

[0066] In some implementations, the common segment can be positioned along a surface of the core opposite the magnet. The core can be between the magnet and the antenna.

[0067] In some implementations, the common segment can be positioned along a surface of the core that extends along the axis of the axially-extending tool. The tool can further include an additional magnet, where the core is between the magnet and the additional magnet.

[0068] In some implementations, the first loop and the second loop can be between the core and a point beyond the radial periphery of the tool. The system can include an electronic controller in communication with the magnet and the antenna assembly. The electronic controller can be programmed to cause the magnet to induce a first magnetic field at the point and to cause the antenna assembly to induce a radio frequency magnetic field at the point. The radio frequency magnetic field can be orthogonal to the first magnetic field at the point.

[0069] In some implementations, the first loop can be symmetric to the second loop.

[0070] In some implementations, the first loop can further include a first segment, the second loop can further include a second segment, the common segment can extend from a first trace, and the first segment and the second segment can converge into a second trace. The common segment can diverge to form the first segment and the second segment. The common segment, the first segment, and the second segment can extend axially from a notional arc, and the common segment can extend axially from a center of the arc. The first segment and the second segment can extend axially from positions on the arc a distance from the center of the arc. An angular distance between the common segment and the first segment can be in a range from about 80 degrees to about 85 degrees relative to a focus of the arc.

[0071] In some implementations, the one or more other surfaces can include a planar surface.

[0072] In some implementations, the one or more other surfaces can include a curved surface.

[0073] In some implementations, the core can be composed of a material having a relative magnetic permeability in a range from about 9 to 20.

[0074] In some implementations, the common segment can include a plurality of conductors that extend in a common direction.

[0075] In some implementations, the first magnetic field can be a static magnetic field.

[0076] In some implementations, the common segment can be disposed near a surface of the core opposite the magnet.

[0077] In some implementations, the first loop and the second loop can be disposed between the core and a volume beyond the radial periphery of the tool. The system can include an electronic controller in communication with the magnet and the antenna assembly. The electronic controller can be programmed to cause the magnet to induce a first magnetic field at the volume and to cause the antenna assembly to induce a radio frequency magnetic field at the volume. The radio frequency magnetic field can be orthogonal to the first magnetic field at the volume.

[0078] In general, in another aspect, a method includes obtaining an axially extending magnetic resonance well logging tool. The tool includes a magnet, and a core having a first surface facing the magnet and one or more other surfaces facing away from the magnet. The method also includes positioning an antenna along at least one of the one or more other surfaces. The antenna includes a first loop of electrically conductive material and a second loop of electrically conductive material. The first and second loops include a common segment extending along an axis of the axially-extending tool.

[0079] Implementations of this aspect may include one or more of the following features:

[0080] In some implementations, positioning the antenna can include positioning the common segment along a surface of the core opposite the magnet. Positioning the antenna can include positioning the antenna such that the core is between the magnet and the antenna.

[0081] In some implementations, positioning the antenna can include positioning the common segment along a surface of the core that extends along the axis of the axially-extending tool.

[0082] In some implementations, positioning the antenna can include positioning the first loop and the second loop between the core and a point beyond the radial periphery of the tool. The method can further include using the magnet to induce a first magnetic field at the point, and using the antenna assembly to induce a radio frequency magnetic field at the point. The radio frequency magnetic field can be orthogonal to the first magnetic field at the point.

[0083] In some implementations, the first loop can be symmetric to the second loop.

[0084] In some implementations, the first loop can further include a first segment, the second loop can further include a second segment, the common segment can extend from a first trace, and the first segment and the second segment can converge into a second trace. The common segment can diverge to form the first segment and the second segment. Positioning the antenna can include positioning the antenna such that the common segment, the first segment, and the second segment extend axially from a notional arc, and the common segment extends axially from a center of the arc. Positioning the antenna can include positioning the antenna such that the first segment and the second segment extend axially from posi-

tions on the arc a distance from the center of the arc. Positioning the antenna can include positioning the antenna such that an angular distance between the common segment and the first segment is in a range from about 80 degrees to about 85 degrees relative to a focus of the arc.

[0085] In some implementations, positioning the antenna can include positioning the common segment near a surface of the core opposite the magnet.

[0086] In some implementations, positioning the antenna can include positioning the first loop and the second loop between the core and a volume beyond the radial periphery of the tool. The method can further include using the magnet to induce a first magnetic field at the volume, and using the antenna assembly to induce a radio frequency magnetic field at the volume. The radio frequency magnetic field can be orthogonal to the first magnetic field at the volume.

[0087] Accordingly, other embodiments are within the scope of the following claims.

What is claimed is:

1. A nuclear magnetic resonance system for well logging using an axially-extending tool, the system comprising:

- a magnet;
- a core having a first surface facing the magnet and one or more other surfaces facing away from the magnet; and
- an antenna positioned along at least one of the one or more other surfaces, the antenna comprising a first loop of electrically conductive material and a second loop of electrically conductive material, the first and second loops comprising a common segment extending along an axis of the axially-extending tool.

2. The system of claim 1, wherein the common segment is positioned along a surface of the core opposite the magnet.

3. The system of claim 2, wherein the core is between the magnet and the antenna.

4. The system of claim 1, wherein the common segment is positioned along a surface of the core that extends along the axis of the axially-extending tool.

5. The system of claim 4, wherein tool further comprises an additional magnet;

wherein the core is between the magnet and the additional magnet.

6. The system of claim 1, wherein the first loop and the second loop are between the core and a point beyond the radial periphery of the tool.

7. The system of claim 6, comprising an electronic controller in communication with the magnet and the antenna assembly, the electronic controller being programmed to cause the magnet to induce a first magnetic field at the point and to cause the antenna assembly to induce a radio frequency magnetic field at the point, wherein the radio frequency magnetic field is orthogonal to the first magnetic field at the point.

8. The system of claim 1, wherein the first loop is symmetric to the second loop.

9. The system of claim 1, wherein
the first loop further comprises a first segment;
the second loop further comprises a second segment;
the common segment extends from a first trace; and
the first segment and the second segment converge into a second trace.

10. The system of claim 9, wherein the common segment diverges to form the first segment and the second segment.

11. The system of claim 9, wherein the common segment, the first segment, and the second segment extend axially from a notional arc, and the common segment extends axially from a center of the arc.

12. The system of claim 11, wherein the first segment and the second segment extend axially from positions on the arc a distance from the center of the arc.

13. The system of claim 12, wherein an angular distance between the common segment and the first segment is in a range from about 80 degrees to about 85 degrees relative to a focus of the arc.

14. The system of claim 1, wherein the one or more other surfaces comprise a planar surface.

15. The system of claim 1, wherein the one or more other surfaces comprise a curved surface.

16. The system of claim 1, wherein the core is composed of a material having a relative magnetic permeability in a range from about 9 to 20.

17. The system of claim 1, wherein the common segment comprises a plurality of conductors that extend in a common direction.

18. The system of claim 7, wherein the first magnetic field is a static magnetic field.

19. The system of claim 1, wherein the common segment is disposed near a surface of the core opposite the magnet.

20. The system of claim 1, wherein the first loop and the second loop are disposed between the core and a volume beyond the radial periphery of the tool.

21. The system of claim 20, comprising an electronic controller in communication with the magnet and the antenna assembly, the electronic controller being programmed to cause the magnet to induce a first magnetic field at the volume and to cause the antenna assembly to induce a radio frequency magnetic field at the volume, wherein the radio frequency magnetic field is orthogonal to the first magnetic field at the volume.

22. A method comprising:
obtaining an axially extending magnetic resonance well logging tool comprising:

- a magnet; and
 - a core having a first surface facing the magnet and one or more other surfaces facing away from the magnet;
- positioning an antenna along at least one of the one or more other surfaces, wherein the antenna comprises a first loop of electrically conductive material and a second loop of electrically conductive material, and the first and second loops comprise a common segment extending along an axis of the axially-extending tool.

23. The method of claim 22, wherein positioning the antenna comprises positioning the common segment along a surface of the core opposite the magnet.

24. The method of claim 23, wherein positioning the antenna comprises positioning the antenna such that the core is between the magnet and the antenna.

25. The method of claim 22, wherein positioning the antenna comprises positioning the common segment along a surface of the core that extends along the axis of the axially-extending tool.

26. The method of claim 22, wherein positioning the antenna comprises positioning the first loop and the second loop between the core and a point beyond the radial periphery of the tool.

27. The method of claim **26**, further comprising:
using the magnet to induce a first magnetic field at the point; and
using the antenna assembly to induce a radio frequency magnetic field at the point;
wherein the radio frequency magnetic field is orthogonal to the first magnetic field at the point.

28. The method of claim **22**, wherein the first loop is symmetric to the second loop.

29. The method of claim **22**, wherein the first loop further comprises a first segment;
the second loop further comprises a second segment;
the common segment extends from a first trace; and
the first segment and the second segment converge into a second trace.

30. The method of claim **29**, wherein the common segment diverges to form the first segment and the second segment.

31. The method of claim **29**, wherein positioning the antenna comprises positioning the antenna such that the common segment, the first segment, and the second segment extend axially from a notional arc, and the common segment extends axially from a center of the arc.

32. The method of claim **31**, wherein positioning the antenna comprises positioning the antenna such that the first

segment and the second segment extend axially from positions on the arc a distance from the center of the arc.

33. The method of claim **32**, wherein positioning the antenna comprises positioning the antenna such that an angular distance between the common segment and the first segment is in a range from about 80 degrees to about 85 degrees relative to a focus of the arc.

34. The method of claim **22**, wherein positioning the antenna comprises positioning the common segment near a surface of the core opposite the magnet.

35. The method of claim **22**, wherein positioning the antenna comprises positioning the first loop and the second loop between the core and a volume beyond the radial periphery of the tool.

36. The method of claim **35**, further comprising:

using the magnet to induce a first magnetic field at the volume; and

using the antenna assembly to induce a radio frequency magnetic field at the volume;

wherein the radio frequency magnetic field is orthogonal to the first magnetic field at the volume.

* * * * *