



US 20160171809A1

(19) **United States**

(12) **Patent Application Publication**
Ohtomo

(10) **Pub. No.: US 2016/0171809 A1**

(43) **Pub. Date: Jun. 16, 2016**

(54) **COIN DISCRIMINATION APPARATUS**

G07D 3/14 (2006.01)

G07D 5/08 (2006.01)

(71) Applicant: **Asahi Seiko Kabushiki Kaisha**, Tokyo (JP)

(52) **U.S. Cl.**

CPC .. *G07D 5/02* (2013.01); *G07D 5/08* (2013.01);

G07D 3/128 (2013.01); *G07D 3/14* (2013.01)

(72) Inventor: **Hiroshi Ohtomo**, Saitama (JP)

(57)

ABSTRACT

(73) Assignee: **Asahi Seiko Kabushiki Kaisha**

A coin discrimination apparatus capable of discriminating the denomination and authenticity of coins including bimetallic coins. A first coin detection sensor, located near a guide, obtains a physical characteristic of a peripheral part of a coin moved on a carrying path. A second coin detection sensor, located apart from the guide, obtains a physical characteristic about a central part of the coin. A third coin detection sensor, located on a downstream side of respect to the first sensor, obtains a physical characteristic about the peripheral part of a coin. A fourth coin detection sensor, located downstream of the second sensor and apart from the guide, obtains a physical characteristic about a central part of the coin. An additional physical characteristic about the peripheral part of the coin is obtained by cooperation of the second and third sensors when the coin reaches the third sensor.

(21) Appl. No.: **14/875,549**

(22) Filed: **Oct. 5, 2015**

(30) **Foreign Application Priority Data**

Dec. 16, 2014 (JP) 2014-253853

Publication Classification

(51) **Int. Cl.**

G07D 5/02 (2006.01)

G07D 3/12 (2006.01)

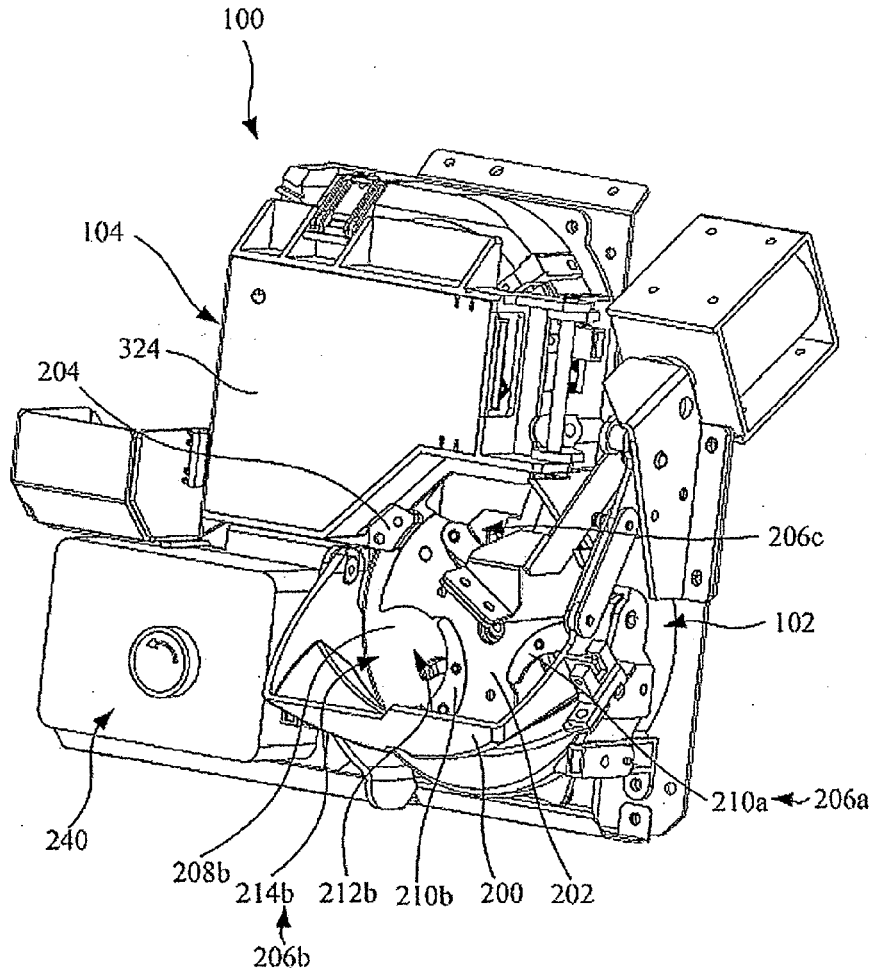

FIG. 1

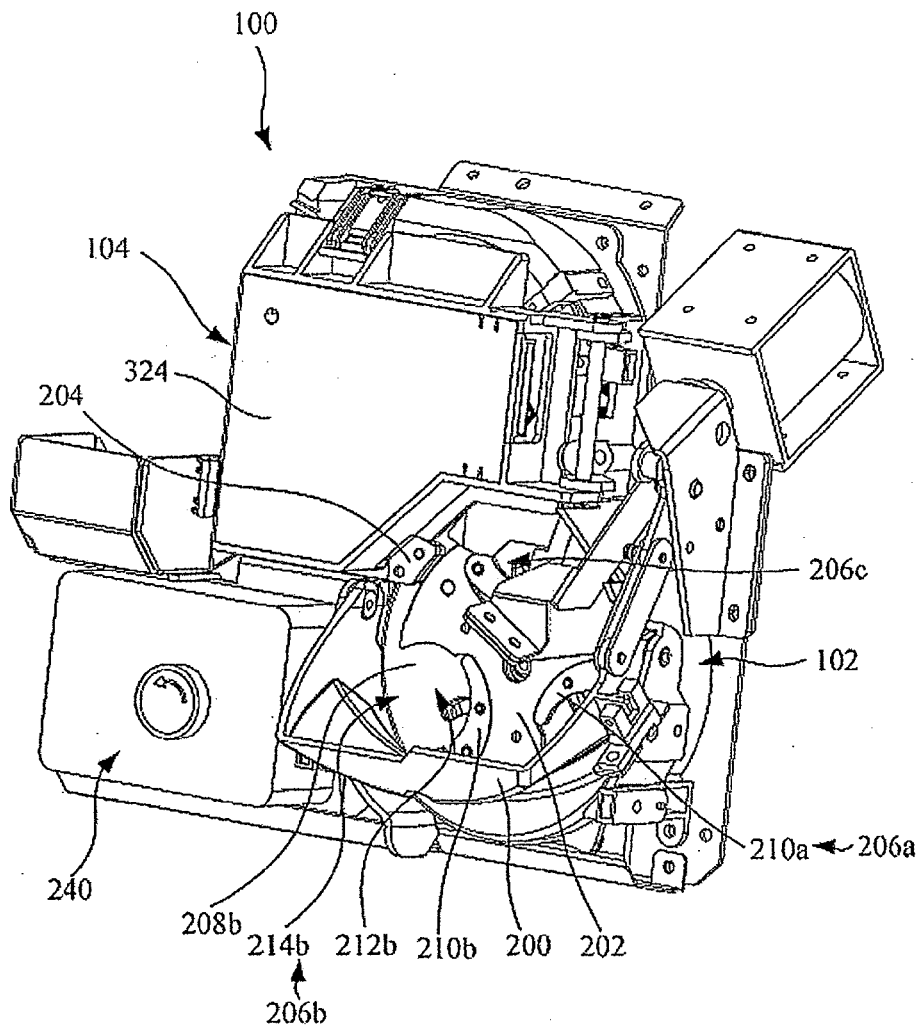

FIG. 2

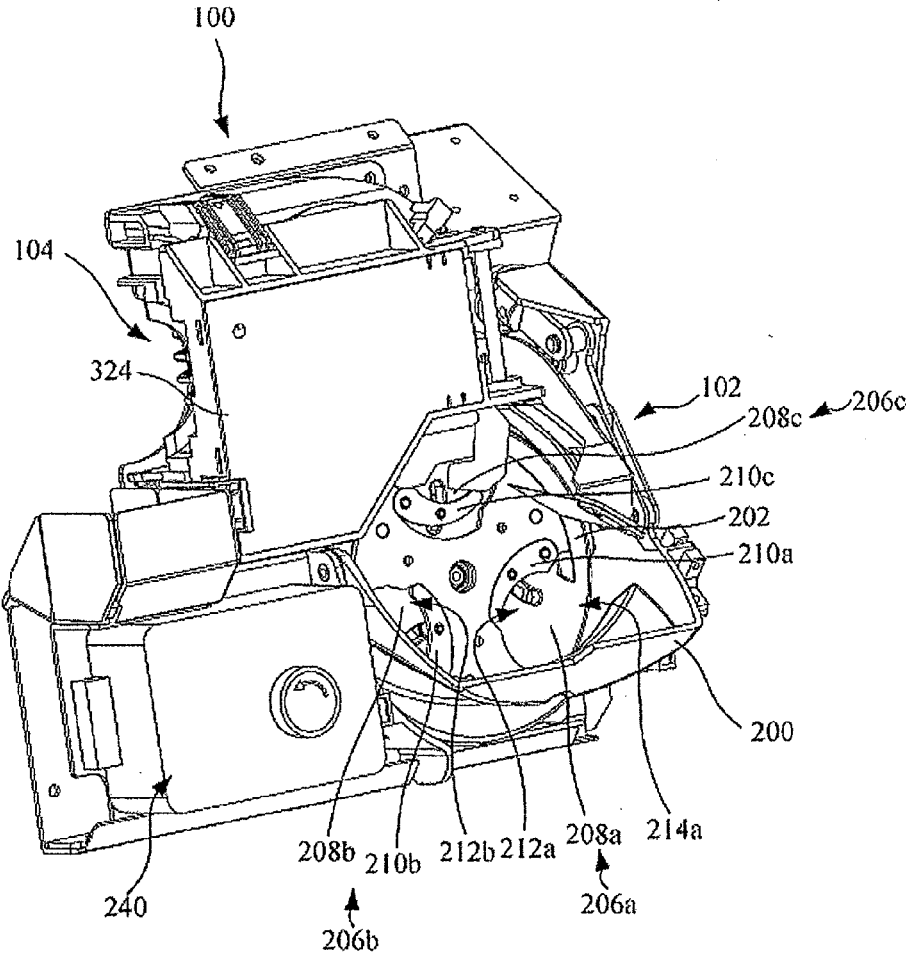

FIG. 3

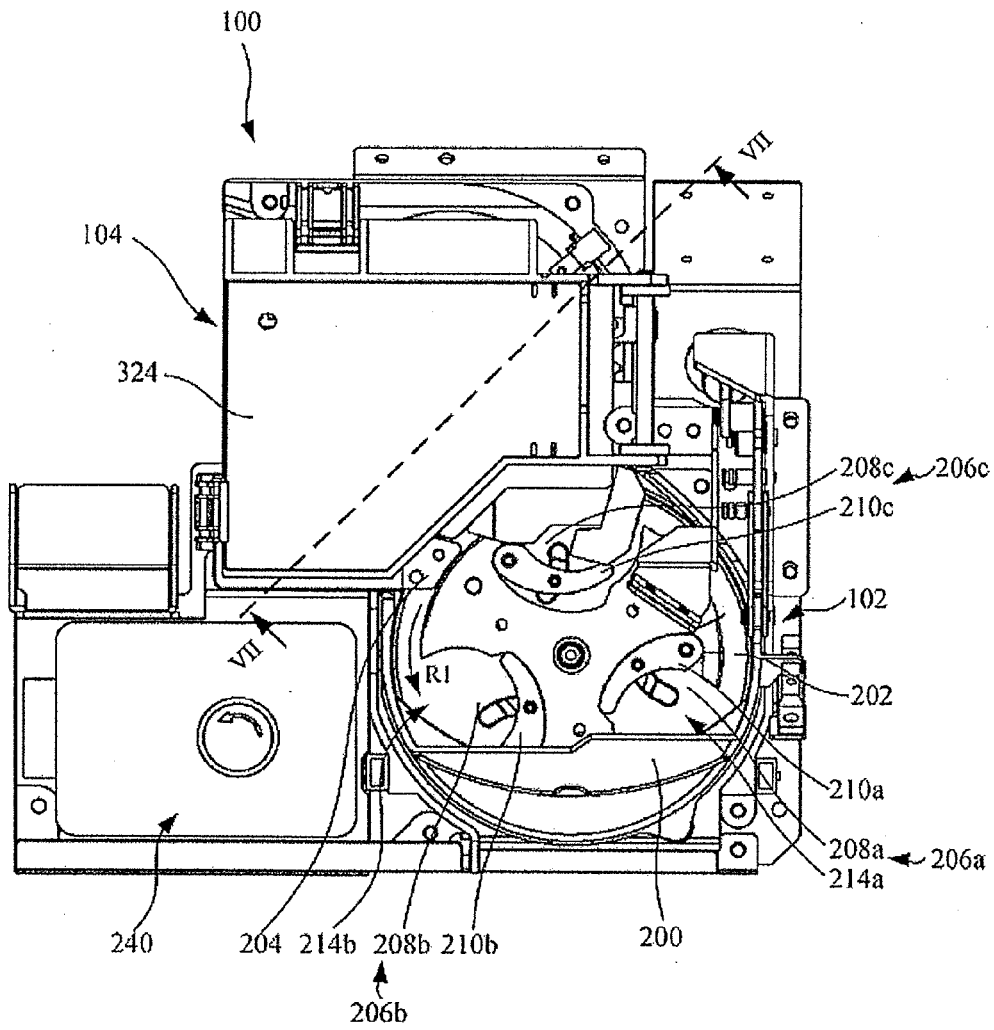

FIG. 4

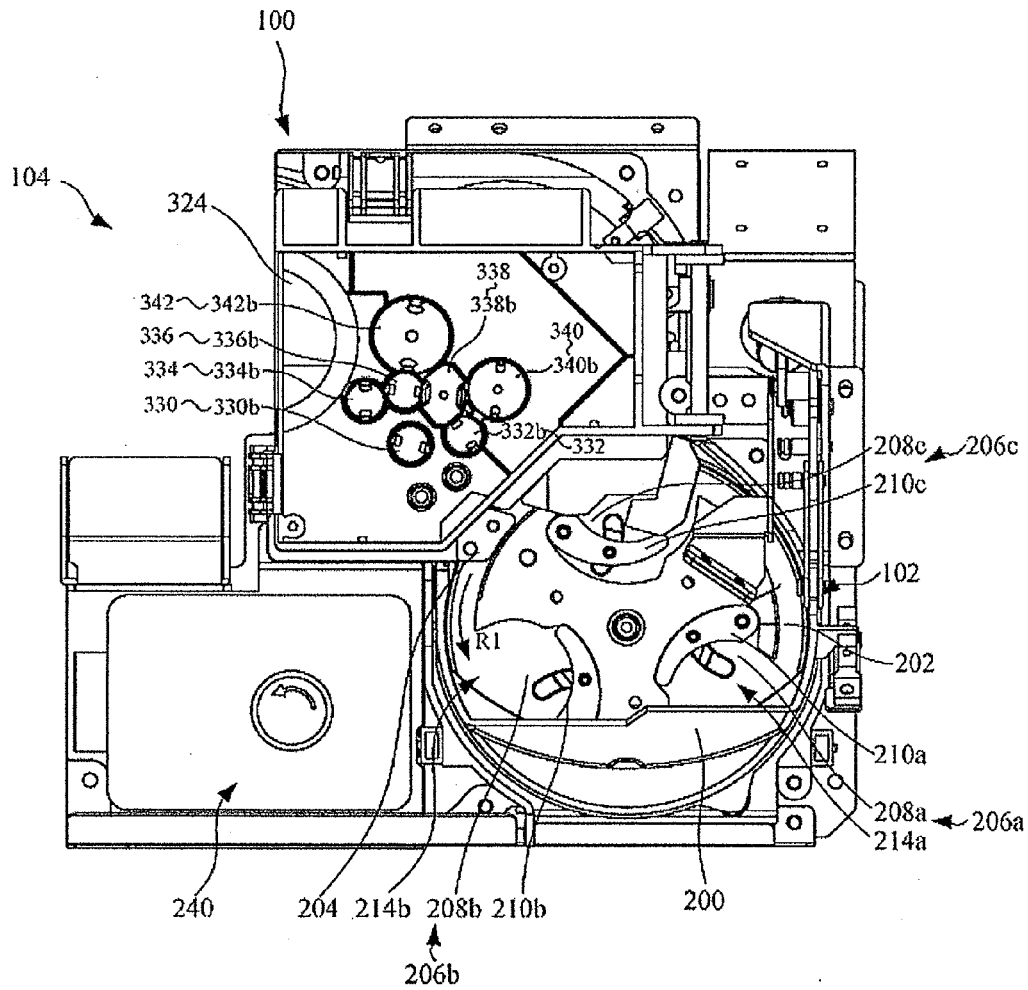

FIG. 5

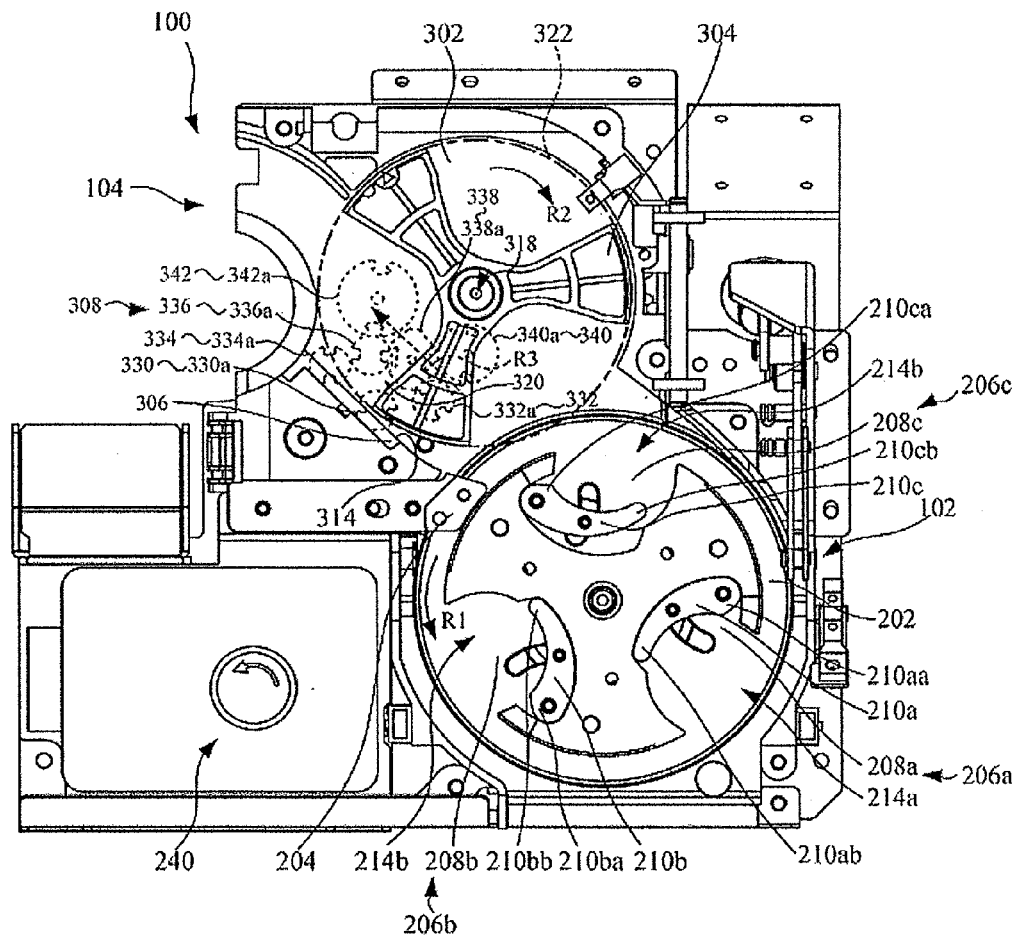

FIG. 6

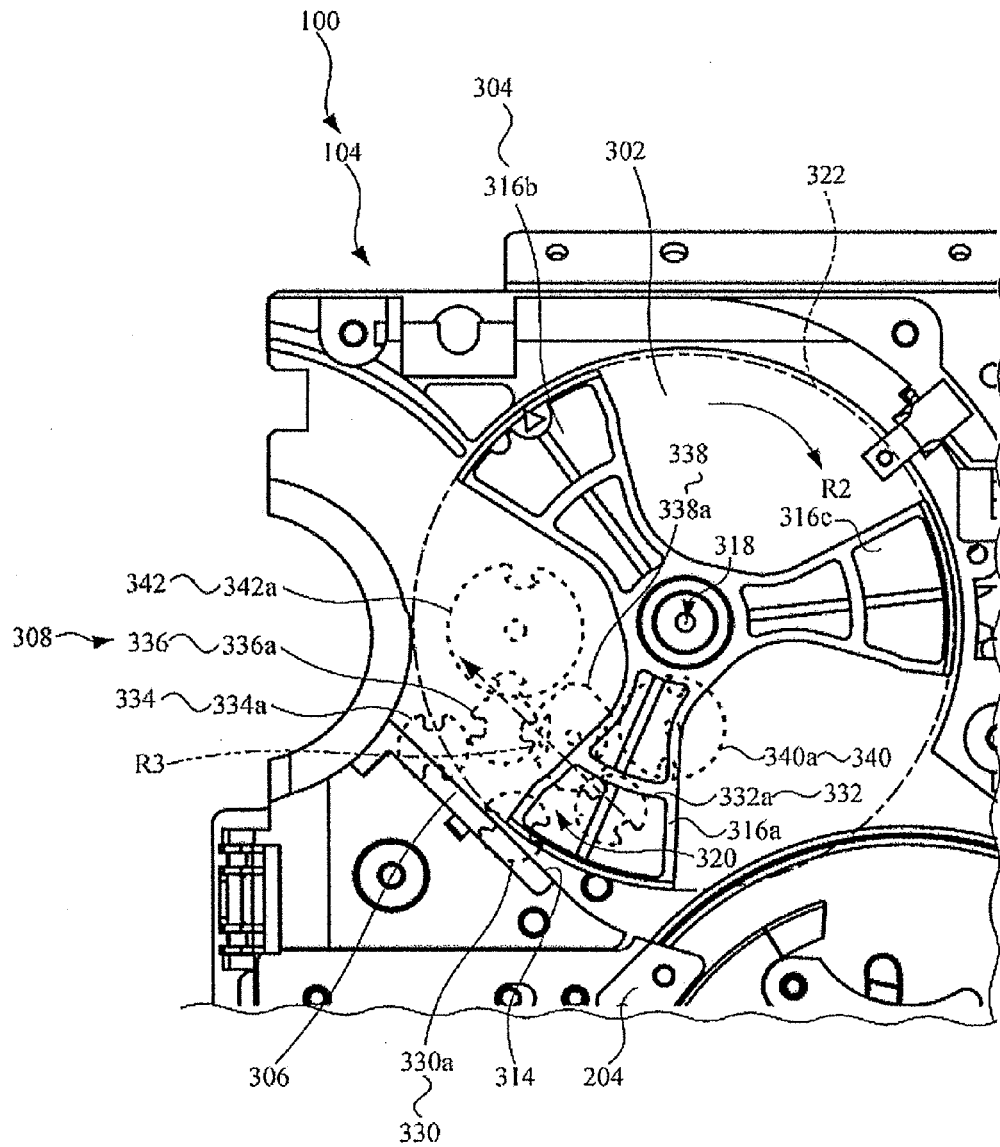

FIG. 7

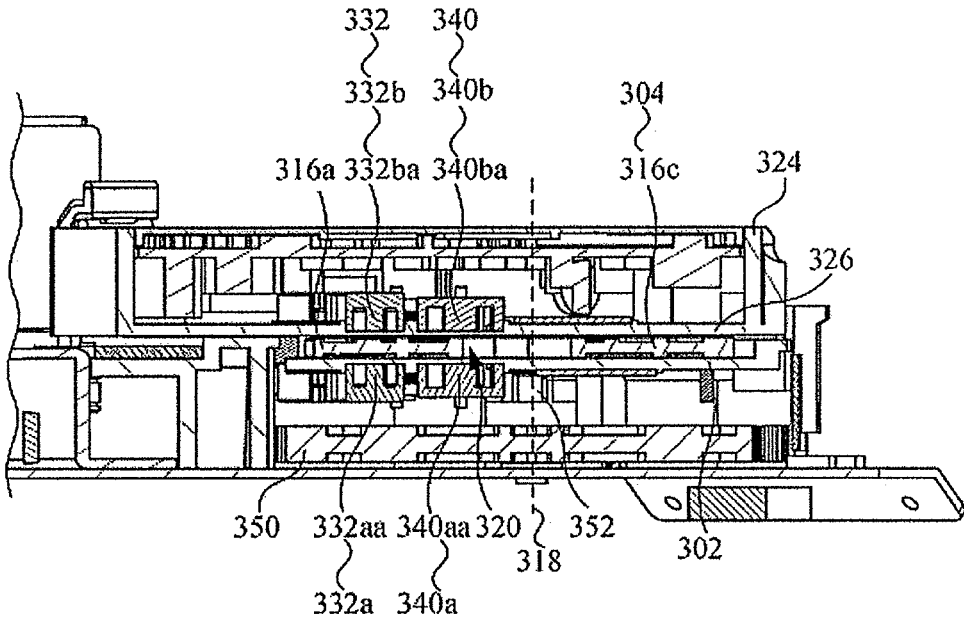

FIG. 8

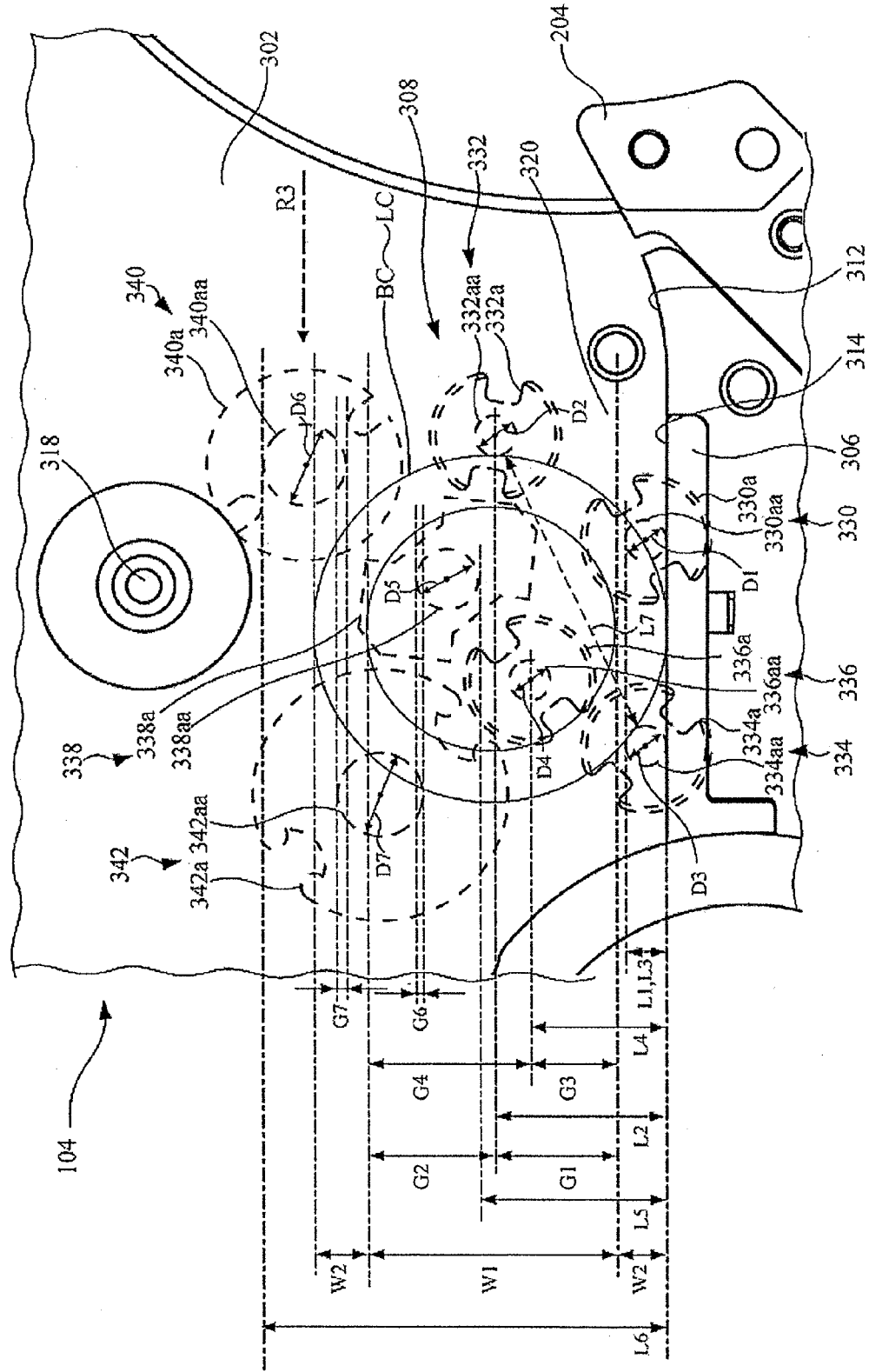
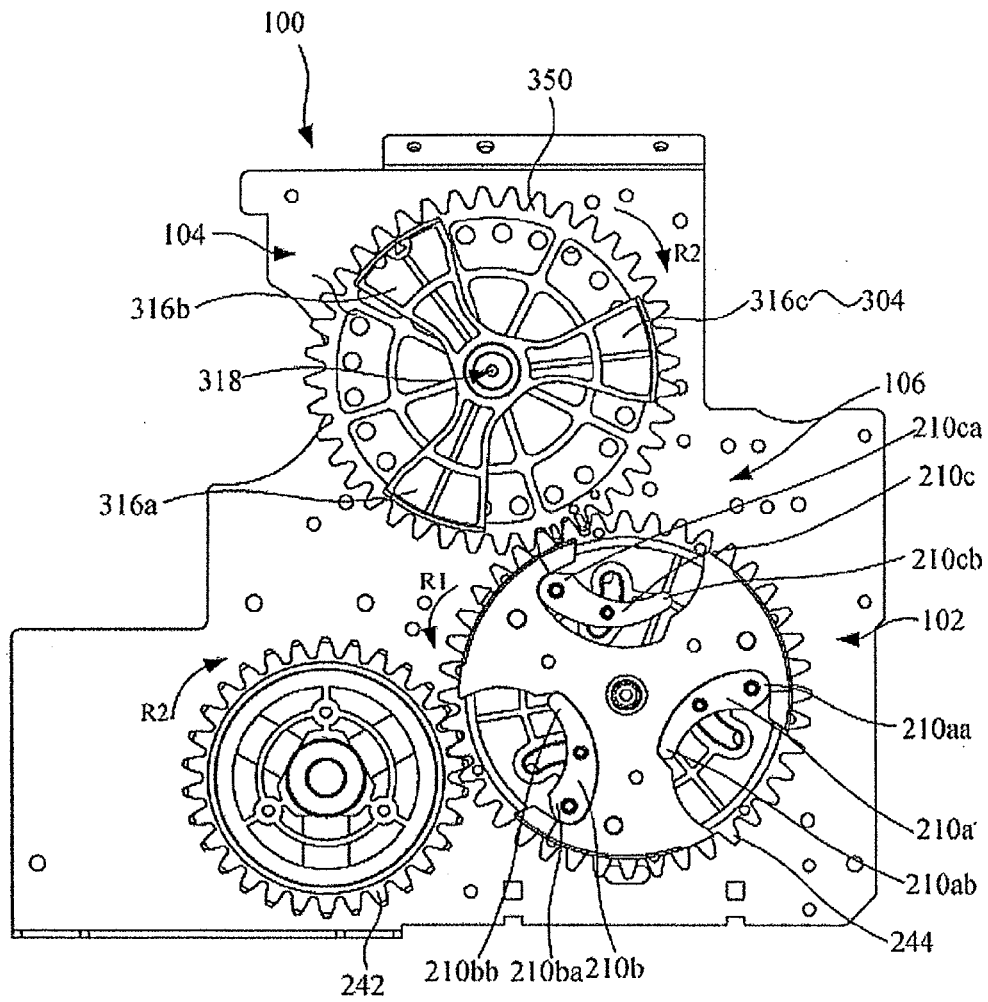

FIG. 9



COIN DISCRIMINATION APPARATUS

BACKGROUND OF THE INVENTION

[0001] 1. Field of the Invention

[0002] The present invention relates to a coin discrimination apparatus and more particularly, to a coin discrimination apparatus that makes it possible to discriminate the denomination and authenticity of coins accurately even if they are bimetallic coins.

[0003] The term "coin" used in this specification means widely coins as a currency, tokens, medals, and so on, which may have any shape such as circular and polygonal ones.

[0004] 2. Description of Related Art

[0005] Conventionally, as a prior art, a coin denomination discrimination apparatus is known, as disclosed, for example, in the Japanese Patent No. 4780494 (see FIGS. 2 to 6 and Paragraphs 0026 to 0040). This apparatus comprises a slide base made of a non-magnetic material, a rotator made of a non-magnetic material and formed adjacent to the slide base in such a way as to be rotated in a plane parallel to the slide base, a reference guide formed outside a rotation path of the rotator, and a magnetic sensing device for discriminating the denomination of coins provided near a coin carrying path through which coins are carried by rotation of the rotator.

[0006] The magnetic sensing device includes a diameter sensor, a material sensor, and a thickness sensor.

[0007] With the prior-art coin denomination discrimination apparatus disclosed in the Japanese Patent No. 4780494, the denomination of target coins is discriminated using one material sensor, one thickness sensor, and three diameter sensors serving as the magnetic sensing device. The material sensor and the thickness sensor are arranged in such a way as to be opposed to not only the central portion of a coin but also the peripheral part thereof.

[0008] When discriminating the denomination of a bimetallic coin, where the peripheral part (ring-shaped part) and the central part (i.e., core part) are made of different metals, the data about the materials of the core and ring-shaped parts of the bimetallic coin is obtained by the material sensor and the data about the material of the connection portion of the core and ring-shaped parts thereof is obtained by the same material sensor. Similarly, the data about the thicknesses of the core and ring-shaped parts is obtained by the thickness sensor and the data about the thickness of the connection portion is obtained by the same thickness sensor. Because the connecting portion contains some structural unevenness, the data obtained from the connecting portion is likely to include dispersion or variations. Accordingly, the data obtained from the connecting portion by the material sensor and the data obtained from the connecting portion by the thickness sensor also will include dispersion or variations, which raises a problem of degradation in discrimination accuracy of bimetallic coins.

SUMMARY OF THE INVENTION

[0009] The present invention was created to solve the abovementioned problem of the prior art coin denomination discrimination apparatus, and an object of the present invention is to provide a coin discrimination apparatus capable of discriminating the denomination and authenticity of coins accurately even if they are bimetallic coins.

[0010] The above object together with others not specifically mentioned will become clear to those skilled in the art from the following description.

[0011] A coin discrimination apparatus according to the present invention comprises:

[0012] a base having a carrying path on which coins are carried, wherein one surface of each coin that is moved on the carrying path is supported by the base;

[0013] a rotator configured to be rotatable around a rotation axis perpendicular to the base, wherein the rotator has pushing members by which coins are carried on the carrying path one by one due to rotation of the rotator;

[0014] a guide formed outside a rotation area of the rotator so as to extend along the carrying path, wherein a coin that is moved on the carrying path is guided by contacting a peripheral face of the coin with the guide; and

[0015] a coin detector for detecting physical characteristics of a coin that is moved on the carrying path, wherein the coin detector is located along the carrying path;

[0016] wherein the coin detector comprises a first coin detection sensor, a second coin detection sensor, a third coin detection sensor, and a fourth coin detection sensor;

[0017] the first coin detection sensor, which is located near the guide, has a function of obtaining a physical characteristic about a peripheral part of a coin that is moved on the carrying path;

[0018] the second coin detection sensor, which is located apart from the guide at a predetermined interval, has a function of obtaining a physical characteristic about a central part of the coin that is moved on the carrying path;

[0019] the third coin detection sensor, which is located on a downstream side of the carrying path at a predetermined interval with respect to the first coin detection sensor and which is located near the guide, has a function of obtaining a physical characteristic about the peripheral part of the coin that is moved on the carrying path;

[0020] the fourth coin detection sensor, which is located on the downstream side of the carrying path at a predetermined interval with respect to the second coin detection sensor and which is located apart from the guide at a predetermined interval, has a function of obtaining a physical characteristic about the central part of the coin that is moved on the carrying path; and

[0021] an additional physical characteristic about the peripheral part of the coin that is moved on the carrying path is obtained by cooperation of the second coin detection sensor and the third coin detection sensor when the coin that is moved on the carrying path reaches the third coin detection sensor.

[0022] With the coin discrimination apparatus according to the present invention, as explained above, the base having the carrying path, the rotator for carrying coins on the carrying path one by one, the guide for guiding the coins along the carrying path, and the coin detector for detecting physical characteristics of the coins are provided. The coins that are moved on the carrying path are carried to a predetermined position through the coin detector itself or through the vicinity of the coin detector. The coins that are carried on the carrying path due to the rotation of the rotator are guided by contacting the peripheral face of the coin with the guide.

[0023] The coin detector comprises the first to fourth coin detection sensors, which are located at different positions with respect to the guide. This means that the positions of the first to fourth coin detection sensors are respectively deter-

mined using the guide as a reference. Moreover, the coin that is moved on the carrying path is guided by contacting the peripheral face of the coin with the guide that extends along the carrying path.

[0024] Therefore, the positional relationships between each of the coins that are carried on the carrying path with the first to fourth coin detection sensors are kept approximately the same for all the coins thus carried. Accordingly, the physical characteristics about the peripheral and core parts of the coin that is moved on the carrying path can be detected accurately with the first to fourth coin detection sensors.

[0025] Furthermore, the additional physical characteristic about the peripheral part of the coin that is moved on the carrying path is obtained by cooperation of the second and third coin detection sensors when the coin that is moved on the carrying path reaches the third coin detection sensor. This means that the physical characteristics about the different positions of the peripheral part of the coin can be detected by the second and third coin detection sensors approximately simultaneously. For this reason, coin discrimination can be performed using not only the physical characteristics obtained by the first to fourth coin detection sensors but also the additional physical characteristic obtained by the cooperation of the second and third coin detection sensors.

[0026] Accordingly, the denomination and authenticity of the coins can be discriminated more accurately compared with the case where the additional physical characteristic is not obtained by the cooperation of the second and third coin detection sensors.

[0027] In the case of discriminating a bimetallic coin comprising a ring-shaped part (i.e., a peripheral part) and a core part (i.e., a central part) which are made of different materials or different-composition materials (e.g., different metals and/or alloys), the physical characteristics about the peripheral part of the bimetallic coin are respectively obtained by the first and third coin detection sensors at different positions, and the physical characteristics about the central part of the bimetallic coin are respectively obtained by the second and fourth coin detection sensors at different positions. Moreover, the additional physical characteristic about the peripheral part of the bimetallic coin is obtained by cooperation of the second and third coin detection sensors.

[0028] Therefore, even if the connecting portion of the bimetallic coin, which connects the ring-shaped part (peripheral part) and the core part (central part), includes some structural unevenness, the physical characteristics obtained by the first to fourth coin detection sensors and the additional physical characteristic obtained by cooperation of the second and third coin detection sensors are unlikely to be affected by the structural unevenness of the connecting portion.

[0029] Accordingly, the denomination and authenticity of coins can be discriminated with high accuracy even if they are bimetallic coins.

[0030] In a preferred embodiment of the coin discrimination apparatus according to the present invention, the physical characteristic about the peripheral part of the coin obtained by the first coin detection sensor is a physical characteristic about a thickness of the peripheral part of the coin, the physical characteristic about the central part of the coin obtained by the second coin detection sensor is a physical characteristic about a material of the central part of the coin, the physical characteristic about the peripheral part of the coin obtained by the third coin detection sensor is a physical characteristic about a material of the peripheral part of the coin, the physical

characteristic about the central part of the coin obtained by the fourth coin detection sensor is a physical characteristic about a thickness of the central part of the coin, and the additional physical characteristic about the peripheral part of the coin obtained by cooperation of the second and third coin detection sensors is a physical characteristic about the material and a diameter of the peripheral part of the coin.

[0031] In this embodiment, since the physical characteristics about the thickness, material, and diameter of the peripheral part of the coin and those about the thickness and material of the central part of thereof are respectively obtained by different coin detection sensors, these characteristics can be detected accurately. Thus, the denomination and authenticity of the coins can be discriminated with high accuracy even if they are bimetallic coins.

[0032] In another preferred embodiment of the coin discrimination apparatus according to the present invention, each of the first to fourth coin detection sensors comprises a pair of magnetic material cores and coils wound respectively around the cores.

[0033] In this embodiment, magnetic characteristics of the coins are detected by the first to fourth coin detection sensors. Therefore, there is an additional advantage that even if dust or rubbish is attached on the first to fourth coin detection sensors, the denomination and authenticity of the coins can be discriminated with high accuracy without the effect of the dust or rubbish.

[0034] In still another preferred embodiment of the coin discrimination apparatus according to the present invention, the coin detector further comprises fifth, sixth, and seventh coin detection sensors. The fifth coin detection sensor is located at a further position from the guide than the second and fourth coin detection sensors. The sixth coin detection sensor is located at a further position from the guide than the fifth coin detection sensor. The seventh coin detection sensor is located on the downstream side of the carrying path with respect to the fifth and sixth coin detection sensors. Each of the fifth to seventh coin detection sensors has a function of obtaining a physical characteristic about a diameter of the coin that is moved on the carrying path.

[0035] In this embodiment, the physical characteristic about the diameter of the coin having a relatively small diameter is obtained by the fifth coin detection sensor, the physical characteristic about the diameter of the coin having a relatively large diameter is obtained by the sixth coin detection sensor, and the physical characteristic about the diameter of the coin having a relatively middle diameter is obtained by the seventh coin detection sensor. Thus, compared with the case where the physical characteristic about the diameter of a coin is obtained by a single coin detection sensor, the physical characteristics about the diameter of the coin can be obtained in more detail. As a result, there is an additional advantage that the denomination and authenticity of the coin can be discriminated with higher accuracy than the case where the coin detector does not comprise the fifth, sixth, and seventh coin detection sensors.

[0036] In a further preferred embodiment of the coin discrimination apparatus according to the present invention, the coin detector further comprises fifth, sixth, and seventh coin detection sensors. The physical characteristic about a diameter of a coin having a relatively small diameter is obtained by the fifth coin detection sensor, the physical characteristic about a diameter of a coin having a relatively large diameter is obtained by the sixth coin detection sensor, and the physical

characteristic about a diameter of a coin having a relatively middle diameter is obtained by the seventh coin detection sensor.

BRIEF DESCRIPTION OF THE DRAWINGS

[0037] The objects and features of the present invention, which are believed to be novel, are set forth with particularity in the appended claims. The present invention, both as to its organization and manner of operation, together with further objects and advantages, may best be understood by reference to the following description, taken in connection with the accompanying drawings.

[0038] FIG. 1 is a perspective view of a coin discrimination apparatus according to an embodiment of the present invention, which is seen from the front right side of the apparatus;

[0039] FIG. 2 is a perspective view of the coin discrimination apparatus according to the embodiment of the present invention, which is seen from the front left side of the apparatus;

[0040] FIG. 3 is a front view of the coin discrimination apparatus according to the embodiment of the present invention;

[0041] FIG. 4 is a front view of the coin discrimination apparatus according to the embodiment of the present invention, which shows the state where the inside of the upper cover of the apparatus is exposed;

[0042] FIG. 5 is a front view of the coin discrimination apparatus according to the embodiment of the present invention, which shows the state where the upper cover of the apparatus is detached;

[0043] FIG. 6 is an enlarged front view of the coin discrimination section of the coin discrimination apparatus shown in FIG. 5;

[0044] FIG. 7 is a cross-sectional view along the line VII-VII in FIG. 3;

[0045] FIG. 8 is an enlarged front view of the detecting part (the coin detector) of the coin discrimination section of the coin discrimination apparatus shown in FIG. 6; and

[0046] FIG. 9 is a front view of the driving mechanism of the coin discrimination apparatus according to the embodiment of the present invention.

DETAILED DESCRIPTION OF THE PREFERRED EMBODIMENTS

[0047] Reference will now be made in detail to the preferred embodiments of the invention which set forth the best modes contemplated to carry out the invention, examples of which are illustrated in the accompanying drawings. While the invention will be described in conjunction with the preferred embodiments, it will be understood that they are not intended to limit the invention to these embodiments. On the contrary, the invention is intended to cover alternatives, modifications and equivalents, which may be included within the spirit and scope of the invention as defined by the appended claims. Furthermore, in the following detailed description of the present invention, numerous specific details are set forth in order to provide a thorough understanding of the present invention. However, it will be obvious to one of ordinary skill in the art that the present invention may be practiced without these specific details. In other instances, well known methods, procedures, components, and circuits have not been described in detail as not to unnecessarily obscure aspects of the present invention.

[0048] Preferred embodiments of the present invention will be described in detail below while referring to the Preferred embodiments of the present invention will be described in detail below while referring to the drawings attached.

[0049] [Overall Structure of Coin Discrimination Apparatus]

[0050] A coin discrimination apparatus 100 according to an embodiment of the present invention is shown in FIGS. 1 to 9.

[0051] As shown in FIGS. 1, 2 and 9, the coin discrimination apparatus 100 comprises a coin separating and forwarding section 102 for separating coins C that are stacked in bulk from each other and forwarding the coins C thus separated toward the next step, a coin discrimination section 104 for carrying the coins C forwarded from the coin separating and forwarding section 102 toward the next step and discriminating the denomination and authenticity of the coins C, and a driving mechanism 106 for driving a carrying mechanism for the coins C. The coin separating and forwarding section 102 is provided at the lower right position of the apparatus 100. The coin discrimination section 104 is provided at the upper middle position of the apparatus 100. The driving mechanism 106 is provided at the lower left and upper middle positions of the apparatus 100.

[0052] The coin separating and forwarding section 102, the coin discrimination section 104, and the driving mechanism 106 of the coin discrimination apparatus 100 may comprise the separated forwarding device disclosed in Japanese Patent No. 4780494 issued in 2011. Since the concrete structure and function of the separated forwarding device are explained in detail in Japanese Patent No. 4780494, the explanation about the structure and function of the separated forwarding device are omitted here.

[0053] Applicant hereby incorporates by reference, the subject matter disclosed by the current inventor in U.S. Pat. No. 7,426,987, issued on Sep. 23, 2008 and assigned to the same assignee.

[0054] [Coin Separating and Forwarding Section]

[0055] Next, the coin separating and forwarding section 102 of the coin discrimination apparatus 100 will be explained below with reference to FIGS. 1 to 5.

[0056] The coin separating and forwarding section 102 has the function of separating coins C that are stacked in bulk from each other and the function of forwarding the coins C thus separated toward the next step. This section 102 comprises a storing container 200, a rotary disk 202, and a receiver 204.

[0057] The rotary disk 202 is obliquely mounted at a predetermined angle and rotated at a predetermined speed. On the upper surface of the disk 202, three coin receiving parts 206a, 206b, and 206c are formed to receive the coins C one by one. Since all the coin receiving parts 206a, 206b, and 206c are the same in structure, the same reference numerals are attached to the structural elements of the parts 206a, 206b, and 206c and at the same time, the parts 206a, 206b, and 206c are distinguished with different suffixes of English alphabet a, b, and c added to the reference numerals in this specification.

[0058] In this embodiment, three coin receiving parts 206a, 206b, and 206c are formed on the upper surface of the rotary disk 202. However, the count of the coin receiving parts may be changed appropriately based on the processing speed in the coin discrimination section 104, the processing speed of an external device or devices (not shown) of the coin discrimination apparatus 100, the diameters of the coins C, and so on.

[0059] The coin receiving parts **206a**, **206b**, and **206c** have depressions **208a**, **208b**, and **208c** for receiving the coins C and pushers **210a**, **210b**, and **210c** located at inner positions with respect to the depressions **208a**, **208b**, and **208c**, respectively. The depressions **208a**, **208b**, and **208c** have openings **212a**, **212b**, and **212c** formed at the upper side of the disk **202**, and openings **214a**, **214b**, and **214c** formed at the peripheral edge side of the disk **202**, respectively. The depressions **208a**, **208b**, and **208c** have the same plan shape like a U character.

[0060] The pushers **210a**, **210b**, and **210c** are located at one sides of the depressions **208a**, **208b**, and **208c** in such a way as to extend along the inner edges of the depressions **208a**, **208b**, and **208c**, respectively. In the ordinary state where the coins C can be received, one ends of the pushers **210a**, **210b**, and **210c** are respectively located at the sides of the peripheral edge openings **214a**, **214b**, and **214c** of the depressions **208a**, **208b**, and **208c** and at the same time, the other ends of the pushers **210a**, **210b**, and **210c** are respectively located at the positions near the center of the disk **202**.

[0061] As clearly shown in FIG. 5, the peripherally positioned ends **210aa**, **210ba**, and **210ca** of the pushers **210a**, **210b**, and **210c**, which are respectively located at the peripheral edge openings **214a**, **214b**, and **214c**, are rockably supported by the disk **202**. The pushers **210a**, **210b**, and **210c** are configured in such a way that the pushers **210a**, **210b**, and **210c** are respectively pivoted on their ends **210aa**, **210ba**, and **210ca** in conjunction with the rotation of the disk **202** and that the internally-positioned ends **210ab**, **210bb**, and **210cb** of the pushers **210a**, **210b**, and **210c** are respectively moved toward the peripheral edge openings **214a**, **214b**, and **214c** due to their pivot movements.

[0062] The sizes (widths) of the coin receiving parts **206a**, **206b**, and **206c** are set to be equal to or greater than the diameter of a maximum diameter coin and less than twice as much as the diameter of a minimum diameter coin. The heights of the coin receiving parts **206a**, **206b**, and **206c** are set to be equal to or less than the thickness of a thinnest coin. Therefore, in the state where two or more coins C are aligned in parallel to the upper surface of the disk **202**, these coins C are unable to be received by each of the coin receiving parts **206a**, **206b**, and **206c**. Moreover, even if two or more coins C are stacked perpendicular to the upper surface of the disk **202**, the coin or coins C other than the lowest-positioned one is/are unable to be received by each of the coin receiving parts **206a**, **206b**, and **206c**.

[0063] Because of the aforementioned structure of the coin receiving parts **206a**, **206b**, and **206c**, only a single coin C is received by each of the coin receiving parts **206a**, **206b**, and **206c** and the coins C thus received are respectively pushed out through the peripherally positioned openings **214a**, **214b**, and **214c** with the pushers **210a**, **210b**, and **210c** that are pivoted in conjunction with the rotation of the disk **202** in the first rotation direction R1. In this way, the coins C thus received are successively forwarded to the next step (i.e., the coin discrimination section **104**) from the respective openings **214a**, **214b**, and **214c**.

[0064] [Coin Discrimination Section]

[0065] Next, the coin discrimination section **104** of the coin discrimination apparatus **100** will be explained below with reference to FIGS. 1 to 8.

[0066] The coin discrimination section **104** has the function of discriminating the denomination and authenticity of the coins C sent out from the coin separating and forwarding section **102** one by one. The coin discrimination section **104**

comprises a base **302** that supports one of the two surfaces of the coin C, a rotator **304** that pushes the peripheral face of the coin C, a guide **306** that guides linearly the coin C moved by the pushing operation of the rotator **304**, and a detecting part (i.e., a coin detector) **308** that detects predetermined physical characteristics of the coin C moved by the pushing operation of the rotator **304**.

[0067] As shown in FIG. 5, the base **302** is formed by a non-magnetic material such as a synthetic resin. The surface of the base **302** is formed flat. The rotator **304** is placed on the surface of the base **302** so as to be rotatable around a rotation axis perpendicular to the same surface of the base **302**. The surface of the base **302** is approximately flush with the upper surface of the rotary disk **202** of the coin separating and forwarding section **102**. By these structures, the coins C can be transferred smoothly from the coin separating and forwarding section **102** to the coin discrimination section **104**. In other words, the coins C can be carried smoothly to a carrying path **320** by way of the receiver **204** from the coin receiving parts **206a**, **206b**, and **206c** of the coin separating and forwarding section **102**. Several strip-like protrusions that extend in the guiding direction of the coins C may be formed on the surface of the base **302** in order to reduce the friction force between the surface of the base **302** and the opposing surface of the coin C.

[0068] The rotator **304** has the function of pushing the peripheral face of the coin C that has been received from the coin separating and forwarding section **102** and sending out the coin C thus pushed to the next step. The rotator **304** is formed by a non-magnetic material such as a synthetic resin. The rotator **304**, which is placed in parallel to the surface of the base **302**, is configured to be rotatable around a rotation axis **318** perpendicular to the surface of the base **302**. The rotator **304** comprises three blade-shaped pushing members **316a**, **316b**, and **316c** arranged at equal intervals around the rotation axis **318**, where the pushing members **316a**, **316b**, and **316c** are extended in the directions approximately perpendicular to the axis **318** (in other words, extended along the surface of the base **302**). Because of the necessity of receiving the coins C that have been sent out one by one from the coin separating and forwarding section **102**, the pushing members **316a**, **316b**, and **316c** are respectively provided so as to correspond to the coin receiving parts **206a**, **206b**, and **206c** of the disk **202**. In other words, the rotator **304** comprises the pushing members **316a**, **316b**, and **316c** that are respectively provided corresponding to the coin receiving parts **206a**, **206b**, and **206c**. The coins C that have been sent out successively from the coin receiving parts **206a**, **206b**, and **206c** to the receiver **204** are successively pushed by the pushers **210a**, **210b**, and **210c** of the rotator **304** rotating in the second rotation direction R2 and thereafter, these coins C are carried on the carrying path **320** on the base **302**.

[0069] In addition, the count of the pushing members **316a**, **316b**, and **316c** may be changed appropriately according to the count of the coin receiving parts **206a**, **206b**, and **206c** and/or the relationship between the rotation speed of the disk **202** and the rotation speed of the rotator **304**.

[0070] The guide **306**, shown in FIGS. 5, 6, and 8, has the function of guiding the peripheral face of a coin C that is pushed and moved by the rotator **304**. The guide **306** is located outside the rotation path **322** of the peripheral ends of the pushing members **316a**, **316b**, and **316c** and is placed adjacent to the receiver **204**. The guide **306** comprises an arc-shaped part **312** formed so as to be continuous with the

receiver **204** in such a way that a small gap is formed between the arc-shaped part **312** and the receiver **204**, and a linear part **314** formed so as to be continuous with the arc-shaped part **312**. A coin C, which is rotated by the rotator **304** on the base **302**, is guided by the linear part **314** of the guide **306** by contacting the peripheral face of the coin C with the linear part **314**. By such the structure and operation, the coin C can be guided linearly on the carrying path **320** on the base **302** in the extension direction of the linear part **314**, i.e., the carrying direction R3, as shown in FIG. 6.

[0071] In addition, although the guide **306** is formed to be separated from the base **302** in this embodiment, the present invention is not limited to this. The guide **306** and the base **302** may be integrated with each other.

[0072] The surface of the base **302** is covered with a cover **324**. A control section for controlling the operation of the coin discrimination apparatus **100** is placed in the cover **324**. The cover **324** is attached to the base **302** in such a way as to be opened and closed. In the closed state, the rotator **304** and the carrying path **320** are covered with the cover **324**. In the opened state, the rotator **304** and the carrying path **320** are exposed from the cover **324**. The bottom **326** of the cover **324**, which is opposite to the surface of the base **302** in the closed state of the cover **324**, is formed flat. The clearance between the bottom **326** of the cover **324** and the surface of the base **302** is set to be slightly larger than the maximum thickness of coins C. By this structure, coins c that are moved in conjunction with the rotation of the rotator **304** can be prevented from being displaced in the direction perpendicular to the surface of the base **302**, which means that the coins C are carried stably on the carrying path **320** formed on the surface of the base **302**.

[0073] The detecting part or coin detector **308** comprises a plurality of coin detection sensors and has the function of discriminating the denomination and authenticity of coins C based on the physical characteristics of the coins C obtained by these sensors. In this embodiment, as shown in FIG. 6, the detecting part or coin detector **308** comprises first, second, third, fourth, fifth, sixth, and seventh coin detection sensors **330**, **332**, **334**, **336**, **338**, **340**, and **342**. Each of the first to seventh coin detection sensors **330**, **332**, **334**, **336**, **338**, **340**, and **342** is formed by a magnetic sensor comprising a pair of magnetic material cores and coils wound around the respective cores.

[0074] Specifically, the first coin detection sensor **330** comprises a pair of magnetic material cores **330a** and **330b**, and coils (not shown) which are respectively wound around the central cores **330aa** and **330ba** of the cores **330a** and **330b**. The second coin detection sensor **332** comprises a pair of magnetic material cores **332a** and **332b**, and coils (not shown) which are respectively wound around the central cores **332aa** and **332ba** of the cores **332a** and **332b**. The third coin detection sensor **334** comprises a pair of magnetic material cores **334a** and **334b**, and coils (not shown) which are respectively wound around the central cores **334aa** and **334ba** of the cores **334a** and **334b**. The fourth coin detection sensor **336** comprises a pair of magnetic material cores **336a** and **336b**, and coils (not shown) which are respectively wound around the central cores **336aa** and **336ba** of the cores **336a** and **336b**. The fifth coin detection sensor **338** comprises a pair of magnetic material cores **338a** and **338b**, and coils (not shown) which are respectively wound around the central cores **338aa** and **338ba** of the cores **338a** and **338b**. The sixth coin detection sensor **340** comprises a pair of magnetic material cores

340a and **340b**, and coils (not shown) which are respectively wound around the central cores **340aa** and **340ba** of the cores **340a** and **340b**. The seventh coin detection sensor **342** comprises a pair of magnetic material cores **342a** and **342b**, and coils (not shown) which are respectively wound around the central cores **342aa** and **342ba** of the cores **342a** and **342b**.

[0075] The first to seventh coin detection sensors **330**, **332**, **334**, **336**, **338**, **340**, and **342** are arranged along the carrying path **320** formed on the base **302**. As shown in FIG. 7, the magnetic material cores **330a**, **332a**, **334a**, **336a**, **338a**, **340a**, and **342a** are arranged on the rear side of the base **302**. On the other hand, the magnetic material cores **330b**, **332b**, **334b**, **336b**, **338b**, **340b**, and **342b** are arranged in the cover **324** placed on the front side of the base **302**, specifically, on the opposite side of the bottom **326** of the cover **324** to the carrying path **320**. Furthermore, the magnetic material cores **330a**, **332a**, **334a**, **336a**, **338a**, **340a**, and **342a** and the magnetic material cores **330b**, **332b**, **334b**, **336b**, **338b**, **340b**, and **342b** are respectively opposite to each other in such a way that the carrying path **320** intervenes between the former cores and the latter cores. Accordingly, coins C that are being carried on the carrying path **320** pass through the region sandwiched by the combination of the magnetic material cores **330a**, **332a**, **334a**, **336a**, **338a**, **340a**, and **342a** and that of the magnetic material cores **330b**, **332b**, **334b**, **336b**, **338b**, **340b**, and **342b**.

[0076] The first and fourth coin detection sensors **330** and **336** are configured to obtain the physical characteristics about the thickness of a coin C carried on the carrying path **320**. The second and third coin detection sensors **332** and **334** are configured to obtain the physical characteristics about the material of a coin C carried on the carrying path **320**.

[0077] As shown in FIG. 8, the first coin detection sensor **330**, which is placed near the linear part **314** of the guide **306**, is configured in such a way that the pair of central cores **330aa** and **330ba** of the first sensor **330** is opposed to the peripheral part of a coin C. The pair of central cores **330aa** and **330ba** of the first sensor **330** is arranged in such a way that the guide-side ends of the central cores **330aa** and **330ba** are in contact with the linear part **314** of the guide **306**. Furthermore, the pair of central cores **330aa** and **330ba** is placed in the range where only the peripheral part of a coin C that is carried in the carrying direction R3 passes through, and the diameters D1 of the central cores **330aa** and **330ba** are defined in such a way as not to be opposite to the central part of the coin C. In other words, the distance L1 from the linear part **314** of the guide **306** to the opposite ends (i.e., the remote-side ends) of the central cores **330aa** and **330ba** to the guide **306** is defined.

[0078] The second coin detection sensor **332**, which is distant from the first coin detection sensor **330**, is configured in such a way that the pair of central cores **332aa** and **332ba** of the second sensor **332** is opposed to the central part of a coin C. In other words, the distance L2 from the linear part **314** of the guide **306** to the centers of the central cores **332aa** and **332ba** and the diameter D2 of the central cores **332aa** and **332ba** are defined in such a way that the pair of central cores **332aa** and **332ba** is placed in the range where the central part of a coin C that is carried in the carrying direction R3 passes through, and that the pair of central cores **332aa** and **332ba** is not opposed to the peripheral part of the coin C.

[0079] The third coin detection sensor **334** is placed on the downstream side of the carrying path **320** at a predetermined distance with respect to the first coin detection sensor **330**. Moreover, the third sensor **334**, which is placed near the linear

part 314 of the guide 306, is configured in such a way that the pair of central cores 334aa and 334ba of the third sensor 334 is opposed to the peripheral part of a coin C. The central cores 334aa and 334ba are placed in such a way that the guide-side ends of the central cores 334aa and 334ba are contacted with the linear part 314 of the guide 306. Furthermore, the diameters D3 of the central cores 334aa and 334ba are defined in such a way that the pair of central cores 334aa and 334ba is placed in the range where only the peripheral part of a coin C that is carried in the carrying direction R3 passes through, and that the pair of central cores 334aa and 334ba is not opposed to the central part of the coin C. In other words, the distance L3 from the linear part 314 of the guide 306 to the opposite ends (i.e., the remote-side ends) of the central cores 334aa and 334ba to the guide 306 is defined.

[0080] The fourth coin detection sensor 336 is placed on the downstream side of the carrying path 320 at a predetermined distance with respect to the second coin detection sensor 332. The fourth sensor 336, which is distant from the guide 306 with respect to the third coin detection sensor 334, is configured in such a way that the pair of central cores 336aa and 336ba of the fourth sensor 336 is opposed to the central part of a coin C. In other words, the distance L4 from the linear part 314 of the guide 306 to the centers of the central cores 336aa and 336ba and the diameters D4 of the central cores 336aa and 336ba are defined in such a way that the pair of central cores 336aa and 336ba is placed in the range where the central part of a coin C that is carried in the carrying direction R3 passes through 1 and that the pair of central cores 336aa and 336ba is not opposed to the peripheral part of the coin C.

[0081] Due to the aforementioned configurations of the first to fourth coin detection sensors 330, 332, 334 1 and 336, the physical characteristic about the thickness of only the peripheral part of the coin C can be obtained by the first sensor 330, the physical characteristic about the material of only the central part of the coin C can be obtained by the second sensor 332 1 the physical characteristic about the material of only the peripheral part of the coin C can be obtained by the third sensor 334, and the physical characteristic about the thickness of only the central part of the coin C can be obtained by the fourth sensor 336.

[0082] Moreover, with respect to the second and third sensors 332 and 334, the interval L7 between the pair of central cores 332aa and 332ba of the second sensor 332 and the pair of central cores 334aa and 334ba of the third sensor 334 is defined in such a way that the peripheral edge of the maximum diameter coin LC within target coins C to be discriminated is also faced with the pair of central cores 332aa and 332ba of the second sensor 332 when the peripheral edge of the maximum diameter coin LC is faced with the pair of central cores 334aa and 334ba of the third sensor 334. The coils wound around the pair of magnetic material cores 332a and 332b of the second sensor 332 are electrically connected in series to the coils wound around the pair of magnetic material cores 334a and 334b of the third sensor 334 1 respectively. By such the structure 1 the physical characteristics about the material and diameter of the peripheral part of the coin C can be obtained by cooperation of the second and third sensors 332 and 334.

[0083] Accordingly, by using the physical characteristics about the material and diameter of the peripheral part of a coin c obtained by the cooperation of the second and third sensors 332 and 334 for coin discrimination in addition to the physical

characteristics about the thickness and material of the peripheral and central parts of the coin C obtained by the first to fourth sensors 330/and 336 1 the denomination and authenticity of the coin c can be discriminated more accurately than the case where the physical characteristics about the material and diameter of the peripheral part of the coin C obtained by the cooperation of the second and third sensors 332 and 334 are excluded.

[0084] Here, a case for discriminating a bimetallic coin BC such as a one or two Euro coin will be explained below as an example.

[0085] The first coin detection sensor 330 is located in the vicinity of the linear part 314 of the guide 306 in such a way that the pair of central cores 330aa and 330ba are opposed to the ring-shaped part (i.e., the peripheral part) of a bimetallic coin BC. In other words, the pair of central cores 330aa and 330ba is placed in the range where only the ringshaped part of the bimetallic coin BC passes through and the connecting portion of the core part (i.e., the central part) and the ring-shaped part of the bimetallic coin BC does not pass through. The guide-side ends of the central cores 330aa and 330ba are arranged so as to be contacted with the linear part 314 of the guide 306. The diameters D1 of the central cores 330aa and 330ba are set to be smaller than the width W2 of the ring-shaped part of the bimetallic coin BC (i.e., $D1 < W2$) in such a way that the central cores 330aa and 330ba are not opposed to the connecting portion of the core and ringshaped parts of the bimetallic coin BC. In other words, the distance L1 between the linear part 314 of the guide 306 to the remote-side ends of the central cores 330aa and 330ba is set to be smaller than the width W2 of the ring-shaped part of the bimetallic coin BC ($L1 < W2$). By such the relationship, the physical characteristics about the thickness of only the ring-shaped part of the coin BC can be obtained by the first sensor 330. Therefore, the effect to the physical characteristic about the thickness of the ring-shaped part of the coin BC obtained by the first sensor 330, which is applied by the dispersion or variations in physical characteristic about the thickness of the coin BC caused by the structural unevenness of the connecting portion thereof, can be prevented.

[0086] In addition, in the coin discrimination apparatus 100 according to this embodiment, the diameters D1 of the central cores 330aa and 330ba are set to be equal to the distance L1 between the linear part 314 of the guide 306 and the opposite ends (i.e., the remote-side ends) of the central cores 330aa and 330ba (i.e., $D1 = L1$). However, the present invention is not limited to this. The diameters D1 may be changed appropriately if the distance L1 is set to be smaller than the width W2; this is because it is sufficient that the central cores 330aa and 330ba are configured so as not to be opposed to the connecting portion of the core and ring-shaped parts of the bimetallic coin BC.

[0087] The second sensor 332 is located in such a way that the central cores 332aa and 332ba are opposed to the core part of the bimetallic coin BC. In other words, the central cores 332aa and 332ba are arranged in the range where the core part of the coin BC that is carried in the carrying direction R3 passes through. The distance L2 between the linear part 314 of the guide 306 and the centers of the central cores 332aa and 332ba is set to be larger than the width W2 of the ring-shaped part of the coin BC and smaller than the sum of the diameter W1 of the core part of the coin BC and the width W2 of the ring-shaped part thereof (i.e., $W1 < L2 < W1 + W2$). The diameters D2 of the central cores 332aa and 332ba of the second

sensor **332** are set to be smaller than twice as much as smaller one of the distance $G1$ from the centers of the central cores **332aa** and **332ba** to the guide-side end of the core part of the coin BC in the direction perpendicular to the linear part **314** of the guide **306**, and the distance $G2$ from the centers of the central cores **332aa** and **332ba** to the remoteside end of the core part of the coin BC in the direction perpendicular to the linear part **314** of the guide **306**. Specifically, when the distance $G1$ is smaller than the distance $G2$, (i.e., $G1 < G2$), the diameter $D2$ is set to be smaller than twice as much as the distance $G1$ (i.e., $D2 < G1 \times 2$). On the other hand, when the distance $G2$ is smaller than the distance $G1$ (i.e., $G2 < G1$), the diameter $D2$ is set to be smaller than twice as much as the distance $G2$ (i.e., $D2 < G2 \times 2$). By such the structure, the centers of the central cores **332aa** and **332ba** can be opposed to only the core portion of the coin BC in the process of carrying the coin BC in the carrying direction $R3$. Therefore, the physical characteristic about the material of only the core part of the coin BC can be obtained by the second sensor **332**. Accordingly, the effect to the physical characteristic about the material of the core part of the coin BC obtained by the second sensor **332**, which is applied by the dispersion or variations in physical characteristic about the material of the coin BC caused by the structural unevenness of the connecting portion thereof, can be prevented.

[0088] The third sensor **334** is placed on the downstream side of the carrying path **320** with respect to the first sensor **330**. Moreover, the third sensor **334**, which is placed near the linear part **314** of the guide **306**, is configured in such a way that the pair of central cores **334aa** and **334ba** is opposed to the ring-shaped part of the bimetallic coin BC. In other words, the central cores **334aa** and **334ba** are arranged in the range where only the ring-shaped part of the coin BC passes through and the connecting portion of the core and ring-shaped parts of the coin BC does not pass through. The guide-side ends of the central cores **334aa** and **334ba** are in contact with the linear part **314** of the guide **306**. The diameters $D3$ of the central cores **334aa** and **334ba** are set to be smaller than the width $W2$ of the ring-shaped part of the coin BC (i.e., $D3 < W2$) in order for the central cores **334aa** and **334ba** not to be opposed to the connecting portion of the core and ring-shaped parts of the coin BC. In other words, the distance $L3$ from the linear part **314** of the guide **306** to the remote-side ends of the central cores **334aa** and **334ba** is set to be smaller than the width $W2$ of the ring-shaped part of the coin BC (i.e., $L3 < W2$). Therefore, the physical characteristic about the material of only the ring-shaped part of the coin BC can be obtained by the third sensor **334**. Accordingly, the effect to the physical characteristic about the material of the ring-shaped part of the coin BC obtained by the third sensor **334**, which is applied by the dispersion or variations in physical characteristic about the material of the coin BC caused by the structural unevenness of the connecting portion thereof, can be prevented.

[0089] In addition, in the coin discrimination apparatus **100** according to this embodiment, the diameters $D3$ of the central cores **334aa** and **334ba** are set to be equal to the distance $L3$ between the linear part **314** of the guide **306** and the remoteside ends of the central cores **334aa** and **334ba** (i.e., $D3 = L3$). However, the present invention is not limited to this. The diameters $D3$ may be changed appropriately if the distance $L3$ is set to be smaller than the width $W2$; this is because it is sufficient that the central cores **334aa** and **334ba** are config-

ured so as not to be opposed to the connecting portion of the core and ring-shaped parts of the bimetallic coin BC.

[0090] Further in addition, in the coin discrimination apparatus **100** according to this embodiment, the diameters $D1$ of the central cores **330aa** and **330ba** are set to be equal to the diameters $D3$ of the central cores **334aa** and **334ba** (i.e., $D1 = D3$). However, the present invention is not limited to this. The diameters $D1$ and $D3$ may be changed appropriately.

[0091] The fourth sensor **336** is placed in such a way that the pair of central cores **336aa** and **336ba** is opposed to the core part of the bimetallic coin BC. In other words, the central cores **336aa** and **336ba** are arranged in the range where the core part of the coin BC that is carried in the carrying direction $R3$ passes through. The distance $L4$ between the linear part **314** of the guide **306** and the centers of the central cores **336aa** and **336ba** is set to be larger than the width $W2$ of the ringshaped part of the coin BC and smaller than the sum of the diameter $W1$ of the core part of the coin BC and the width $W2$ of the ring-shaped part thereof (i.e., $W1 < L4 < W1 + W2$). The diameters $D4$ of the central cores **336aa** and **336ba** of the fourth sensor **336** are set to be smaller than twice as much as smaller one of the distance $G3$ from the centers of the central cores **336aa** and **336ba** to the guide-side end of the core part of the bimetallic coin BC in the direction perpendicular to the linear part **314** of the guide **306**, and the distance $G4$ from the centers of the central cores **336aa** and **336ba** to the remote-side end of the core part of the coin BC in the direction perpendicular to the linear part **314** of the guide **306**. Specifically, when the distance $G3$ is smaller than the distance $G4$, (i.e., $G3 < G4$), the diameter $D4$ is set to be smaller than twice as much as the distance $G3$ (i.e., $D4 < G3 \times 2$). On the other hand, when the distance $G4$ is smaller than the distance $G3$ (i.e., $G4 < G3$), the diameter $D4$ is set to be smaller than twice as much as the distance $G4$ (i.e., $D4 < G4 \times 2$). By such the structure, the centers of the central cores **336aa** and **336ba** can be made opposed to only the core portion of the coin BC in the process of carrying the coin BC in the carrying direction $R3$. Therefore, the physical characteristic about the thickness of only the core part of the coin BC can be obtained by the fourth sensor **336**. Accordingly, the effect to the physical characteristic about the thickness of the core part of the coin BC obtained by the fourth sensor **336**, which is applied by the dispersion or variations in physical characteristic about the thickness of the coin BC caused by the structural unevenness of the connecting portion thereof, can be prevented.

[0092] Because of the aforementioned structures and relationships, without being affected by the structural unevenness of the connecting portion of the bimetallic coin BC, the physical characteristic about the thickness of the ring-shaped part of the coin BC is obtained by the first sensor **330**, the physical characteristic about the material of the core part of the coin BC is obtained by the second sensor **332**, the physical characteristic about the material of the ring-shaped part of the coin BC is obtained by the third sensor **334**, and the physical characteristic about the thickness of the core part of the coin BC is obtained by the fourth sensor **336**. This means that the effect of the structural unevenness of the connecting portion of the coin BC can be avoided in any of the first to fourth sensors **330**, **332**, **334**, and **336**. Accordingly, unlike the case where the physical characteristic about one of the thickness and material of the core and ring-shaped parts of a bimetallic coin is obtained by a single coin detection sensor, the physical characteristics of the thickness and material of the core and ring-shaped parts of the bimetallic coin BC can be obtained in

detail, which means that the denomination and authenticity of the bimetallic coin BC can be discriminated with high accuracy.

[0093] Moreover, the second and third sensors **332** and **334** are arranged in such a way that the central cores **332aa** and **332ba** of the second sensor **332** also are opposed to the peripheral part or edge of the bimetallic coin BC when the peripheral edge of the coin BC reaches the central cores **334aa** and **334ba** of the third sensor **334**. In other words, the distance L7 between the central cores **332aa** and **332ba** of the second sensor **332** and the central cores **334aa** and **334ba** of the third sensor **334** is defined in such a way that the central cores **332aa** and **332ba** and the central cores **334aa** and **334ba** are simultaneously opposed to the peripheral edge of the bimetallic coin BC. By such the structure, not only the physical characteristic about the material of the ring-shaped part of the bimetallic coin BC but also the physical characteristic about the diameter of the coin BC can be obtained by the cooperation of the second and third sensors **332** and **334**.

[0094] Accordingly, by using the physical characteristics about the material and diameter of the bimetallic coin BC obtained by the cooperation of the second and third sensors **332** and **334** for coin discrimination in addition to the physical characteristics about the thickness and material of the ring-shaped and core parts of the coin BC obtained by the first to fourth sensors **330**, **332**, **334**, and **336**, the denomination and authenticity of the coin BC can be discriminated more accurately than the case where only the physical characteristics about the material and thickness of the ring-shaped and core parts of the coin BC obtained by the first to fourth sensors **330**, **332**, **334**, and **336** are used.

[0095] In the coin discrimination section **104** of the coin discrimination apparatus **100** according to this embodiment, the physical characteristics about the thickness of the coin c are obtained by the first and fourth sensors **330** and **336** and the physical characteristics about the material of the coin C are obtained by the second and third sensors **332** and **334**. However, the present invention is not limited to this. The physical characteristics about the material of the coin C may be obtained by the first and fourth sensors **330** and **336** and the physical characteristics about the thickness of the coin C may be obtained by the second and third sensors **332** and **334**.

[0096] Moreover, similar to the second and third sensors **332** and **334**, the physical characteristics about the coin C may be obtained by the cooperation of the first and fourth sensors **330** and **336** by connecting the coils of the first and fourth sensors **330** and **336** in series. Furthermore, the positions and sizes of the central cores **330aa**, **330ba**, **332aa**, **332ba**, **334aa**, **334ba**, **336aa**, and **336ba** of the first to fourth sensors **330**, **332**, **334**, and **336**, concretely speaking, each of the distances L1, L2, L3, L4, and L7 and the diameters D1, D2, D3, and D4, may be changed appropriately according to the diameter, material, and so on of a target coin C to be discriminated.

[0097] The fifth, sixth, and seventh sensors **338**, **340**, and **342** have the function of acquiring the physical characteristic about the diameter of a coin C in the state where the fifth, sixth, and seventh sensors **338**, **340**, and **342** are opposed to the opposite peripheral edge (i.e., the remote-side peripheral edge) of a coin C that is carried on the carrying path **320** to the guide **306**.

[0098] The fifth sensor **338** is located to acquire the physical characteristic of a diameter of a minimum diameter coin SC. Specifically, the pair of central cores **338aa** and **338ba** of

the fifth sensor **338** is located in such a way as to be opposed to the remote-side peripheral edge of the minimum diameter coin SC. In other words, the distance L5 between the guide-side end of the central cores **338aa** and **338ba** of the fifth sensor **338** and the linear part **314** of the guide **306** is set to be smaller than the diameter of the minimum diameter coin SC.

[0099] The sixth sensor **340** is located to acquire the physical characteristic of a diameter of a maximum diameter coin LC. Specifically, the pair of central cores **340aa** and **340ba** of the sixth sensor **340** is located in such a way as to be opposed to the remote-side peripheral edge of the maximum diameter coin LC. In other words, the distance L6 between the remote-side ends of the central cores **340aa** and **340ba** of the sixth sensor **340** and the linear part **314** of the guide **306** is set to be larger than the diameter of the maximum diameter coin LC.

[0100] The seventh sensor **342** is placed on the downstream side of the carrying path **320** with respect to the fifth and sixth sensors **338** and **340**. Moreover, the central cores **342aa** and **342ba** of the seventh sensor **342** are arranged between the central cores **338aa** and **338ba** of the fifth sensor **338** and the central cores **340aa** and **340ba** of the sixth sensor **340** in the direction which is perpendicular to the extension direction of the linear part **314** of the guide **306** and which is parallel to the surface of the base **302**.

[0101] By such the structure, the physical characteristic about the diameter of a relatively small diameter coin c can be obtained by the fifth sensor **338**, the physical characteristic about the diameter of a relatively large diameter coin C can be obtained by the sixth sensor **340**, and the physical characteristic about the diameter of a relatively middle diameter coin C can be obtained by the seventh sensor **342**.

[0102] The fifth and seventh sensors **338** and **342** are arranged in such a way that the remote-side ends of the central cores **338aa** and **338ba** of the fifth sensor **338** and the guide-side ends of the central cores **342aa** and **342ba** of the seventh sensor **342** are overlapped with each other by a predetermined length G5 in the direction which is perpendicular to the extension direction of the linear part **314** of the guide **306** and which is parallel to the surface of the base **302**. The sixth and seventh sensors **340** and **342** are arranged in such a way that the guide-side ends of the central cores **340aa** and **340ba** of the sixth sensor **340** and the remote-side ends of the central cores **342aa** and **342ba** of the seventh sensor **342** are overlapped with each other by a predetermined length G6 in the direction which is perpendicular to the extension direction of the linear part **314** of the guide **306** and which is parallel to the surface of the base **302**.

[0103] By such the structure of the fifth to seventh sensors **338**, **340**, and **342**, the physical characteristic about the diameter of a coin C can be obtained by the fifth to seventh sensors **338**, **340**, and **342** even in the state where the boundary between the central cores **338aa** and **338ba** of the fifth sensor **338** and the central cores **342aa** and **342ba** of the seventh sensor **342** and the boundary between the central cores **340aa** and **340ba** of the sixth sensor **340** and the central cores **342aa** and **342ba** of the seventh sensor **342** are opposed to the peripheral edge of the coin C.

[0104] The fifth to seventh sensors **338**, **340**, and **342** are arranged in such a way that the physical characteristic about the diameter of a relatively small diameter coin C can be obtained by the fifth sensor **338**, the physical characteristic about the diameter of a relatively large diameter coin C can be obtained by the sixth sensor **340**, and the physical characteristic about the diameter of a relatively middle diameter coin C

can be obtained by the seventh sensor **342** within the target coins *c* to be discriminated. This means that the physical characteristic about the diameter of a coin *C* is obtained by one of the fifth to seventh sensors **338**, **340**, and **342** according to the diameter value of a coin *C*. Accordingly, compared with the case where the physical characteristic about the diameter of a coin is obtained by a single coin detection sensor, the physical characteristic about the diameter of a coin *C* can be obtained in more detail, which means that the denomination and authenticity of a coin *c* can be discriminated with higher accuracy by using the physical characteristic about the diameter of the coin *C* obtained by the second and third sensors **332** and **334** along with the physical characteristics about the diameter of the coin *C* obtained respectively by the fifth to seventh sensors **338**, **340**, and **342**.

[0105] In addition, the arrangements or layouts of the first to seventh coin detection sensors **330**, **332**, **334**, **336**, **338**, **340**, and **342** may be changed appropriately according to the length of the carrying path **320**, the diameter of target coins to be discriminated and so on. For example, the fifth to seventh sensors **338**, **340**, and **342** may be arranged on the downstream side of the carrying path **320** with respect to the first to fourth sensors **330**, **332**, **334**, and **336**. The second and third sensors **332** and **334** may be arranged on the downstream side of the carrying path **320** with respect to the first to fourth sensors **330**, **332**, **334**, and **336**.

[0106] [Driving Mechanism]

[0107] Next, the driving mechanism **106** of the coin discrimination apparatus **100** will be explained below with reference to FIG. 9.

[0108] The driving mechanism **106** has the function of driving or rotating the rotary disk **202** of the coin separating and forwarding section **102** and the rotator **304** of the coin discrimination section **104**. The driving mechanism **106** comprises a driving gear **242** that receives driving power from a driving source **240**, a first driven gear **244** that rotates the disk **202**, and a second driven gear **350** that rotates the rotator **304**.

[0109] The driving gear **242** is connected to the output shaft of a motor (not shown) as the driving source **240**. The first driven gear **244**, which is in the form of a spur gear, is integrally configured with the disk **202** on the rear side of the disk **202**. Therefore, the disk **202** is rotated along with the rotation of the first driven gear **244**. Moreover, the second driven gear **350**, which is in the form of a spur gear, is placed on the rear side of the base **302**. The second driven gear **350** is configured to be rotatable around the rotation axis **318**, and is fixed to the rotator **304** with a rotational shaft **352** penetrating through the base **302** along the rotation axis **318**. Therefore, the rotator **304** is rotated along with the rotation of the second driven gear **350**.

[0110] In the driving mechanism **106**, the first driven gear **244** is drivingly connected to the driving gear **242**, and the second driven gear **350** is drivingly connected to the first driven gear **244**. For this reason, if the driving gear **242** is rotated in the second rotation direction **R2**, the first driven gear **244** is rotated in the first rotation direction **R1**. If the first driven gear **244** is rotated in the first rotation direction **R1**, the second driven gear **350** is rotated in the second rotation direction **R2**. Accordingly, the first driven gear **244** and the disk **202** are rotated in the first direction **R1** along with the rotation of the driving gear **242** in the second direction **R2** and then, the second driven gear **350** and the rotator **304** are rotated in the second direction **R2**.

[0111] The gear ratio of the first and second driven gears **244** and **350** is fixed at 1:1. The rotation of the disk **202** and the rotation of the rotator **304** are synchronized in such a way that coins *C* are rotated by the pushing members **316a**, **316b**, and **316c** of the rotator **304** immediately after the coins *C* which have been sent out from each of the coin receiving parts **206a**, **206b**, and **206c** are received by the receiver **204**.

[0112] The gear ratio of the first and second driven gears **244** and **350** is not limited to 1:1 and may be changed appropriately according to the ratio between the count of the coin receiving parts **206** of the disk **202** and the count of the pushing members **316** of the rotator **304**.

[0113] [Advantageous Effects of Coin Discrimination Apparatus]

[0114] With the coin discrimination apparatus **100** according to the embodiment of the present invention, as explained above in detail, the base **302** having the carrying path **320**, the rotator **304** for carrying coins *C* on the carrying path **320** one by one, the guide **306** for guiding the coins *C* along the carrying path **320**, and the coin detector **308** for detecting physical characteristics of the coins *C* are provided. The coins *C* that are moved on the carrying path **320** are carried to a predetermined position through the coin detector **308** itself or through the vicinity of the coin detector **308**. The coins *C* that are carried on the carrying path **320** due to the rotation of the rotator **304** are guided by contacting the peripheral face of the coin *C* with the guide **306**.

[0115] The coin detector **308** comprises the first to fourth coin detection sensors **330**, **332**, **334**, and **336**, which are located at different positions with respect to the guide **306**. This means that the positions of the first to fourth coin detection sensors **330**, **332**, **334**, and **336** are respectively determined using the guide **306** as a reference. Moreover, the coin *C* that is moved on the carrying path **320** is guided by contacting the peripheral face of the coin *c* with the guide **306** that extends along the carrying path **320**.

[0116] Therefore, the positional relationships between each of the coins *C* that are carried on the carrying path **320** with the first to fourth coin detection sensors **330**, **332**, **334**, and **336** are kept approximately the same for all the coins *C* thus carried. Accordingly, the physical characteristics about the peripheral and core parts of the coin *C* that is moved on the carrying path **320** can be detected accurately with the first to fourth coin detection sensors **330**, **332**, **334**, and **336**.

[0117] Furthermore, the additional physical characteristic about the peripheral part of the coin *C* that is moved on the carrying path **320** is obtained by cooperation of the second and third coin detection sensors **332** and **334** when the coin *C* that is moved on the carrying path **320** reaches the third coin detection sensor **334**. This means that the physical characteristics about the different positions of the peripheral part of the coin *C* can be detected by the second and third coin detection sensors **332** and **334** approximately simultaneously. For this reason, coin discrimination can be performed using not only the physical characteristics obtained by the first to fourth coin detection sensors **330**, **332**, **334**, and **336** but also the additional physical characteristic obtained by the cooperation of the second and third coin detection sensors **332** and **334**.

[0118] Accordingly, the denomination and authenticity of the coins *C* can be discriminated more accurately compared with the case where the additional physical characteristic is not obtained by the cooperation of the second and third coin detection sensors **332** and **334**.

[0119] In the case of discriminating a bimetallic coin BC comprising a ring-shaped part (i.e., a peripheral part) and a core part (i.e., a central part) which are made of different materials or different-composition materials (e.g., different metals and/or alloys), the physical characteristics about the peripheral part of the bimetallic coin BC are respectively obtained by the first and third coin detection sensors 330 and 334 at different positions, and the physical characteristics about the central part of the bimetallic coin BC are respectively obtained by the second and fourth coin detection sensors 332 and 336 at different positions. Moreover, the additional physical characteristic about the peripheral part of the bimetallic coin BC is obtained by cooperation of the second and third coin detection sensors 332 and 334.

[0120] Therefore, even if the connecting portion of the bimetallic coin BC, which connects the ring-shaped part (peripheral part) and the core part (central part), includes some structural unevenness, the physical characteristics obtained by the first to fourth coin detection sensors 330, 332, 334, and 336 and the additional physical characteristic obtained by cooperation of the second and third coin detection sensors 332 and 334 are unlikely to be affected by the structural unevenness of the connecting portion.

[0121] Accordingly, the denomination and authenticity of coins C can be discriminated with high accuracy even if they are bimetallic coins BC.

[0122] Furthermore, in the aforementioned coin discrimination apparatus 100 according to this embodiment, the coin detector 308 further comprises the fifth, sixth, and seventh coin detection sensors 338, 340, and 342. The fifth coin detection sensor 338 is located at a further position from the guide 306 than the second and fourth coin detection sensors 332 and 336. The sixth coin detection sensor 340 is located at a further position from the guide 306 than the fifth coin detection sensor 338. The seventh coin detection sensor 342 is located on the downstream side of the carrying path 320 with respect to the fifth and sixth coin detection sensors 338 and 340. Each of the fifth to seventh coin detection sensors 338, 340, and 342 has the function of obtaining the physical characteristic about the diameter of the coin C that is moved on the carrying path 320.

[0123] Accordingly, the physical characteristic about the diameter of the coin c having a relatively small diameter is obtained by the fifth coin detection sensor 338, the physical characteristic about the diameter of the coin c having a relatively large diameter is obtained by the sixth coin detection sensor 340, and the physical characteristic about the diameter of the coin having a relatively middle diameter is obtained by the seventh coin detection sensor 342. Thus, compared with the case where the physical characteristic about the diameter of the coin C is obtained by a single coin detection sensor, the physical characteristics about the diameter of the coin C can be obtained in more detail.

[0124] As a result, there is an additional advantage that the denomination and authenticity of the coin can be discriminated with higher accuracy than the case where the coin detector 308 does not comprise the fifth, sixth, and seventh coin detection sensors 338, 340, and 342.

[0125] Variations

[0126] It is needless to say that the present invention is not limited to the above-described embodiment and its variations. Any other modification is applicable to the embodiment and variations.

[0127] For example, in the aforementioned coin discrimination apparatus 100 according to the embodiment of the present invention, the structure of the coin separating and forwarding section 102 is not limited to the one explained in this embodiment. For example, the coin separating and forwarding apparatus disclosed in the Japanese Non-Examined Patent Publication No. 2014-041396 may be used for the coin separating and forwarding section 102. The coin separating and forwarding apparatus of the Publication No. 2014-041396 comprises a moving member that is reciprocated linearly along the diameter direction of a rotary disk in conjunction with the rotation of the disk. Coins C are separated from each other by the moving member and then, forwarded to the next process.

[0128] The structural elements and their shapes and sizes are preferred examples of the present invention; it is needless to say that any other structural elements may be used and these shapes and sized may be changed according to the necessity.

[0129] The present invention is applicable to any type of coin processing apparatuses for processing coins. For example, the present invention may be preferably applied to change machines, money changers, vending machines, automated teller machines, ticket-vending machines and so on.

[0130] While the preferred forms of the present invention have been described, it is to be understood that modifications will be apparent to those skilled in the art without departing from the spirit of the invention. The scope of the present invention, therefore, is to be determined solely by the following claimistics of the thickness and material of the core and ring-shaped parts of the bimetallic coin BC can be obtained in detail, which means that the denomination and authenticity of the bimetallic coin BC can be discriminated with high accuracy.

[0131] Moreover, the second and third sensors 332 and 334 are arranged in such a way that the central cores 332aa and 332ba of the second sensor 332 also are opposed to the peripheral part or edge of the bimetallic coin BC when the peripheral edge of the coin BC reaches the central cores 334aa and 334ba of the third sensor 334. In other words, the distance L7 between the central cores 332aa and 332ba of the second sensor 332 and the central cores 334aa and 334ba of the third sensor 334 is defined in such a way that the central cores 332aa and 332ba and the central cores 334aa and 334ba are simultaneously opposed to the peripheral edge of the bimetallic coin BC. By such the structure, not only the physical characteristic about the material of the ring-shaped part of the bimetallic coin BC but also the physical characteristic about the diameter of the coin BC can be obtained by the cooperation of the second and third sensors 332 and 334.

[0132] Accordingly, by using the physical characteristics about the material and diameter of the bimetallic coin BC obtained by the cooperation of the second and third sensors 332 and 334 for coin discrimination in addition to the physical characteristics about the thickness and material of the ring-shaped and core parts of the coin BC obtained by the first to fourth sensors 330, 332, 334, and 336, the denomination and authenticity of the coin BC can be discriminated more accurately than the case where only the physical characteristics about the material and thickness of the ring-shaped and core parts of the coin BC obtained by the first to fourth sensors 330, 332, 334, and 336 are used.

[0133] In the coin discrimination section 104 of the coin discrimination apparatus 100 according to this embodiment,

the physical characteristics about the thickness of the coin *c* are obtained by the first and fourth sensors **330** and **336** and the physical characteristics about the material of the coin *C* are obtained by the second and third sensors **332** and **334**. However, the present invention is not limited to this. The physical characteristics about the material of the coin *C* may be obtained by the first and fourth sensors **330** and **336** and the physical characteristics about the thickness of the coin *C* may be obtained by the second and third sensors **332** and **334**.

[0134] Moreover, similar to the second and third sensors **332** and **334**, the physical characteristics about the coin *C* may be obtained by the cooperation of the first and fourth sensors **330** and **336** by connecting the coils of the first and fourth sensors **330** and **336** in series. Furthermore, the positions and sizes of the central cores **330aa**, **330ba**, **332aa**, **332ba**, **334aa**, **334ba**, **336aa**, and **336ba** of the first to fourth sensors **330**, **332**, **334**, and **336**, concretely speaking, each of the distances **L1**, **L2**, **L3**, **L4**, and **L7** and the diameters **D1**, **D2**, **D3**, and **D4**, may be changed appropriately according to the diameter, material, and so on of a target coin *C* to be discriminated.

[0135] The fifth, sixth, and seventh sensors **338**, **340**, and **342** have the function of acquiring the physical characteristic about the diameter of a coin *C* in the state where the fifth, sixth, and seventh sensors **338**, **340**, and **342** are opposed to the opposite peripheral edge (i.e., the remote-side peripheral edge) of a coin *C* that is carried on the carrying path **320** to the guide **306**.

[0136] The fifth sensor **338** is located to acquire the physical characteristic of a diameter of a minimum diameter coin *SC*. Specifically, the pair of central cores **338aa** and **338ba** of the fifth sensor **338** is located in such a way as to be opposed to the remote-side peripheral edge of the minimum diameter coin *SC*. In other words, the distance **L5** between the guide-side end of the central cores **338aa** and **338ba** of the fifth sensor **338** and the linear part **314** of the guide **306** is set to be smaller than the diameter of the minimum diameter coin *SC*.

[0137] The sixth sensor **340** is located to acquire the physical characteristic of a diameter of a maximum diameter coin *LC*. Specifically, the pair of central cores **340aa** and **340ba** of the sixth sensor **340** is located in such a way as to be opposed to the remote-side peripheral edge of the maximum diameter coin *LC*. In other words, the distance **L6** between the remote-side ends of the central cores **340aa** and **340ba** of the sixth sensor **340** and the linear part **314** of the guide **306** is set to be larger than the diameter of the maximum diameter coin *LC*.

[0138] The seventh sensor **342** is placed on the downstream side of the carrying path **320** with respect to the fifth and sixth sensors **338** and **340**. Moreover, the central cores **342aa** and **342ba** of the seventh sensor **342** are arranged between the central cores **338aa** and **338ba** of the fifth sensor **338** and the central cores **340aa** and **340ba** of the sixth sensor **340** in the direction which is perpendicular to the extension direction of the linear part **314** of the guide **306** and which is parallel to the surface of the base **302**.

[0139] By such the structure, the physical characteristic about the diameter of a relatively small diameter coin *c* can be obtained by the fifth sensor **338**, the physical characteristic about the diameter of a relatively large diameter coin *C* can be obtained by the sixth sensor **340**, and the physical characteristic about the diameter of a relatively middle diameter coin *C* can be obtained by the seventh sensor **342**.

[0140] The fifth and seventh sensors **338** and **342** are arranged in such a way that the remote-side ends of the central

cores **338aa** and **338ba** of the fifth sensor **338** and the guide-side ends of the central cores **342aa** and **342ba** of the seventh sensor **342** are overlapped with each other by a predetermined length **G5** in the direction which is perpendicular to the extension direction of the linear part **314** of the guide **306** and which is parallel to the surface of the base **302**. The sixth and seventh sensors **340** and **342** are arranged in such a way that the guide-side ends of the central cores **340aa** and **340ba** of the sixth sensor **340** and the remote-side ends of the central cores **342aa** and **342ba** of the seventh sensor **342** are overlapped with each other by a predetermined length **G6** in the direction which is perpendicular to the extension direction of the linear part **314** of the guide **306** and which is parallel to the surface of the base **302**.

[0141] By such the structure of the fifth to seventh sensors **338**, **340**, and **342**, the physical characteristic about the diameter of a coin *C* can be obtained by the fifth to seventh sensors **338**, **340**, and **342** even in the state where the boundary between the central cores **338aa** and **338ba** of the fifth sensor **338** and the central cores **342aa** and **342ba** of the seventh sensor **342** and the boundary between the central cores **340aa** and **340ba** of the sixth sensor **340** and the central cores **342aa** and **342ba** of the seventh sensor **342** are opposed to the peripheral edge of the coin *C*.

[0142] The fifth to seventh sensors **338**, **340**, and **342** are arranged in such a way that the physical characteristic about the diameter of a relatively small diameter coin *C* can be obtained by the fifth sensor **338**, the physical characteristic about the diameter of a relatively large diameter coin *C* can be obtained by the sixth sensor **340**, and the physical characteristic about the diameter of a relatively middle diameter coin *C* can be obtained by the seventh sensor **342** within the target coins *c* to be discriminated. This means that the physical characteristic about the diameter of a coin *C* is obtained by one of the fifth to seventh sensors **338**, **340**, and **342** according to the diameter value of a coin *C*. Accordingly, compared with the case where the physical characteristic about the diameter of a coin is obtained by a single coin detection sensor, the physical characteristic about the diameter of a coin *C* can be obtained in more detail, which means that the denomination and authenticity of a coin *c* can be discriminated with higher accuracy by using the physical characteristic about the diameter of the coin *C* obtained by the second and third sensors **332** and **334** along with the physical characteristics about the diameter of the coin *C* obtained respectively by the fifth to seventh sensors **338**, **340**, and **342**.

[0143] In addition, the arrangements or layouts of the first to seventh coin detection sensors **330**, **332**, **334**, **336**, **338**, **340**, and **342** may be changed appropriately according to the length of the carrying path **320**, the diameter of target coins to be discriminated and so on. For example, the fifth to seventh sensors **338**, **340**, and **342** may be arranged on the downstream side of the carrying path **320** with respect to the first to fourth sensors **330**, **332**, **334**, and **336**. The second and third sensors **332** and **334** may be arranged on the downstream side of the carrying path **320** with respect to the first to fourth sensors **330**, **332**, **334**, and **336**.

[0144] [Driving Mechanism]

[0145] Next, the driving mechanism **106** of the coin discrimination apparatus **100** will be explained below with reference to FIG. 9.

[0146] The driving mechanism **106** has the function of driving or rotating the rotary disk **202** of the coin separating and forwarding section **102** and the rotator **304** of the coin

discrimination section 104. The driving mechanism 106 comprises a driving gear 242 that receives driving power from a driving source 240, a first driven gear 244 that rotates the disk 202, and a second driven gear 350 that rotates the rotator 304.

[0147] The driving gear 242 is connected to the output shaft of a motor (not shown) as the driving source 240. The first driven gear 244, which is in the form of a spur gear, is integrally configured with the disk 202 on the rear side of the disk 202. Therefore, the disk 202 is rotated along with the rotation of the first driven gear 244. Moreover, the second driven gear 350, which is in the form of a spur gear, is placed on the rear side of the base 302. The second driven gear 350 is configured to be rotatable around the rotation axis 318, and is fixed to the rotator 304 with a rotational shaft 352 penetrating through the base 302 along the rotation axis 318. Therefore, the rotator 304 is rotated along with the rotation of the second driven gear 350.

[0148] In the driving mechanism 106, the first driven gear 244 is drivingly connected to the driving gear 242, and the second driven gear 350 is drivingly connected to the first driven gear 244. For this reason, if the driving gear 242 is rotated in the second rotation direction R2, the first driven gear 244 is rotated in the first rotation direction R1. If the first driven gear 244 is rotated in the first rotation direction R1, the second driven gear 350 is rotated in the second rotation direction R2. Accordingly, the first driven gear 244 and the disk 202 are rotated in the first direction R1 along with the rotation of the driving gear 242 in the second direction R2 and then, the second driven gear 350 and the rotator 304 are rotated in the second direction R2.

[0149] The gear ratio of the first and second driven gears 244 and 350 is fixed at 1:1. The rotation of the disk 202 and the rotation of the rotator 304 are synchronized in such a way that coins C are rotated by the pushing members 316a, 316b, and 316c of the rotator 304 immediately after the coins C which have been sent out from each of the coin receiving parts 206a, 206b, and 206c are received by the receiver 204.

[0150] The gear ratio of the first and second driven gears 244 and 350 is not limited to 1:1 and may be changed appropriately according to the ratio between the count of the coin receiving parts 206 of the disk 202 and the count of the pushing members 316 of the rotator 304.

[0151] [Advantageous Effects of Coin Discrimination Apparatus]

[0152] With the coin discrimination apparatus 100 according to the embodiment of the present invention, as explained above in detail, the base 302 having the carrying path 320, the rotator 304 for carrying coins C on the carrying path 320 one by one, the guide 306 for guiding the coins C along the carrying path 320, and the coin detector 308 for detecting physical characteristics of the coins C are provided. The coins C that are moved on the carrying path 320 are carried to a predetermined position through the coin detector 308 itself or through the vicinity of the coin detector 308. The coins C that are carried on the carrying path 320 due to the rotation of the rotator 304 are guided by contacting the peripheral face of the coin C with the guide 306.

[0153] The coin detector 308 comprises the first to fourth coin detection sensors 330, 332, 334, and 336, which are located at different positions with respect to the guide 306. This means that the positions of the first to fourth coin detection sensors 330, 332, 334, and 336 are respectively determined using the guide 306 as a reference. Moreover, the coin C that is moved on the carrying path 320 is guided by con-

tacting the peripheral face of the coin c with the guide 306 that extends along the carrying path 320.

[0154] Therefore, the positional relationships between each of the coins C that are carried on the carrying path 320 with the first to fourth coin detection sensors 330, 332, 334, and 336 are kept approximately the same for all the coins C thus carried. Accordingly, the physical characteristics about the peripheral and core parts of the coin C that is moved on the carrying path 320 can be detected accurately with the first to fourth coin detection sensors 330, 332, 334, and 336.

[0155] Furthermore, the additional physical characteristic about the peripheral part of the coin C that is moved on the carrying path 320 is obtained by cooperation of the second and third coin detection sensors 332 and 334 when the coin C that is moved on the carrying path 320 reaches the third coin detection sensor 334. This means that the physical characteristics about the different positions of the peripheral part of the coin C can be detected by the second and third coin detection sensors 332 and 334 approximately simultaneously. For this reason, coin discrimination can be performed using not only the physical characteristics obtained by the first to fourth coin detection sensors 330, 332, 334, and 336 but also the additional physical characteristic obtained by the cooperation of the second and third coin detection sensors 332 and 334.

[0156] Accordingly, the denomination and authenticity of the coins C can be discriminated more accurately compared with the case where the additional physical characteristic is not obtained by the cooperation of the second and third coin detection sensors 332 and 334.

[0157] In the case of discriminating a bimetallic coin BC comprising a ring-shaped part (i.e., a peripheral part) and a core part (i.e., a central part) which are made of different materials or different-composition materials (e.g., different metals and/or alloys), the physical characteristics about the peripheral part of the bimetallic coin BC are respectively obtained by the first and third coin detection sensors 330 and 334 at different positions, and the physical characteristics about the central part of the bimetallic coin BC are respectively obtained by the second and fourth coin detection sensors 332 and 336 at different positions. Moreover, the additional physical characteristic about the peripheral part of the bimetallic coin BC is obtained by cooperation of the second and third coin detection sensors 332 and 334.

[0158] Therefore, even if the connecting portion of the bimetallic coin BC, which connects the ring-shaped part (peripheral part) and the core part (central part), includes some structural unevenness, the physical characteristics obtained by the first to fourth coin detection sensors 330, 332, 334, and 336 and the additional physical characteristic obtained by cooperation of the second and third coin detection sensors 332 and 334 are unlikely to be affected by the structural unevenness of the connecting portion.

[0159] Accordingly, the denomination and authenticity of coins C can be discriminated with high accuracy even if they are bimetallic coins BC.

[0160] Furthermore, in the aforementioned coin discrimination apparatus 100 according to this embodiment, the coin detector 308 further comprises the fifth, sixth, and seventh coin detection sensors 338, 340, and 342. The fifth coin detection sensor 338 is located at a further position from the guide 306 than the second and fourth coin detection sensors 332 and 336. The sixth coin detection sensor 340 is located at a further position from the guide 306 than the fifth coin detection sensor 338. The seventh coin detection sensor 342 is located

on the downstream side of the carrying path **320** with respect to the fifth and sixth coin detection sensors **338** and **340**. Each of the fifth to seventh coin detection sensors **338**, **340**, and **342** has the function of obtaining the physical characteristic about the diameter of the coin **C** that is moved on the carrying path **320**.

[0161] Accordingly, the physical characteristic about the diameter of the coin **c** having a relatively small diameter is obtained by the fifth coin detection sensor **338**, the physical characteristic about the diameter of the coin **c** having a relatively large diameter is obtained by the sixth coin detection sensor **340**, and the physical characteristic about the diameter of the coin having a relatively middle diameter is obtained by the seventh coin detection sensor **342**. Thus, compared with the case where the physical characteristic about the diameter of the coin **C** is obtained by a single coin detection sensor, the physical characteristics about the diameter of the coin **C** can be obtained in more detail.

[0162] As a result, there is an additional advantage that the denomination and authenticity of the coin can be discriminated with higher accuracy than the case where the coin detector **308** does not comprise the fifth, sixth, and seventh coin detection sensors **338**, **340**, and **342**.

[0163] Variations

[0164] It is needless to say that the present invention is not limited to the above-described embodiment and its variations. Any other modification is applicable to the embodiment and variations.

[0165] For example, in the aforementioned coin discrimination apparatus **100** according to the embodiment of the present invention, the structure of the coin separating and forwarding section **102** is not limited to the one explained in this embodiment. For example, the coin separating and forwarding apparatus disclosed in the Japanese Non-Examined Patent Publication No. 2014-041396 may be used for the coin separating and forwarding section **102**. The coin separating and forwarding apparatus of the Publication No. 2014-041396 comprises a moving member that is reciprocated linearly along the diameter direction of a rotary disk in conjunction with the rotation of the disk. Coins **C** are separated from each other by the moving member and then, forwarded to the next process.

[0166] The structural elements and their shapes and sizes are preferred examples of the present invention; it is needless to say that any other structural elements may be used and these shapes and sizes may be changed according to the necessity.

[0167] The present invention is applicable to any type of coin processing apparatuses for processing coins. For example, the present invention may be preferably applied to change machines, money changers, vending machines, automated teller machines, ticket-vending machines and so on.

[0168] While the preferred forms of the present invention have been described, it is to be understood that modifications will be apparent to those skilled in the art without departing from the spirit of the invention. The scope of the present invention, therefore, is to be determined solely by the following claims

What is claimed is:

1. A coin discrimination apparatus comprising:

a base having a carrying path on which coins are carried, wherein one surface of each coin that is moved on the carrying path is supported by the base;

a rotator configured to be rotatable around a rotation axis perpendicular to the base, wherein the rotator has pushing members by which coins are carried on the carrying path one by one due to rotation of the rotator;

a guide formed outside a rotation area of the rotator so as to extend along the carrying path, wherein a coin that is moved on the carrying path is guided by contacting a peripheral face of the coin with the guide; and

a coin detector for detecting physical characteristics of a coin that is moved on the carrying path, wherein the coin detector is located along the carrying path;

wherein the coin detector comprises a first coin detection sensor, a second coin detection sensor, a third coin detection sensor, and a fourth coin detection sensor;

the first coin detection sensor, which is located near the guide, has a function of obtaining a physical characteristic about a peripheral part of a coin that is moved on the carrying path;

the second coin detection sensor, which is located apart from the guide at a predetermined interval, has a function of obtaining a physical characteristic about a central part of the coin that is moved on the carrying path;

the third coin detection sensor, which is located on a downstream side of the carrying path at a predetermined interval with respect to the first coin detection sensor and which is located near the guide, has a function of obtaining a physical characteristic about the peripheral part of the coin that is moved on the carrying path;

the fourth coin detection sensor, which is located on the downstream side of the carrying path at a predetermined interval with respect to the second coin detection sensor and which is located apart from the guide at a predetermined interval, has a function of obtaining a physical characteristic about the central part of the coin that is moved on the carrying path; and

an additional physical characteristic about the peripheral part of the coin that is moved on the carrying path is obtained by cooperation of the second coin detection sensor and the third coin detection sensor when the coin that is moved on the carrying path reaches the third coin detection sensor.

2. The coin discrimination apparatus according to claim 1, wherein the physical characteristic about the peripheral part of the coin obtained by the first coin detection sensor is a physical characteristic about a thickness of the peripheral part of the coin;

the physical characteristic about the central part of the coin obtained by the second coin detection sensor is a physical characteristic about a material of the central part of the coin;

the physical characteristic about the peripheral part of the coin obtained by the third coin detection sensor is a physical characteristic about a material of the peripheral part of the coin;

the physical characteristic about the central part of the coin obtained by the fourth coin detection sensor is a physical characteristic about a thickness of the central part of the coin; and

the additional physical characteristic about the peripheral part of the coin obtained by cooperation of the second and third coin detection sensors is a physical characteristic about the material and a diameter of the peripheral part of the coin.

3. The coin discrimination apparatus according to claim 1 wherein each of the first to fourth coin detection sensors comprises a pair of magnetic material cores and coils wound respectively around the cores.

4. The coin discrimination apparatus according to claim 1, wherein the coin detector further comprises fifth, sixth, and seventh coin detection sensors;

the fifth coin detection sensor is located at a further position from the guide than the second and fourth coin detection sensors;

the sixth coin detection sensor is located at a further position from the guide than the fifth coin detection sensor;

the seventh coin detection sensor is located on the downstream side of the carrying path with respect to the fifth and sixth coin detection sensors; and

each of the fifth to seventh coin detection sensors has a function of obtaining a physical characteristic about a diameter of the coin that is moved on the carrying path.

5. The coin discrimination apparatus according to claim 2, wherein the coin detector further comprises fifth, sixth, and seventh coin detection sensors;

the fifth coin detection sensor is located at a further position from the guide than the second and fourth coin detection sensors;

the sixth coin detection sensor is located at a further position from the guide than the fifth coin detection sensor;

the seventh coin detection sensor is located on the downstream side of the carrying path with respect to the fifth and sixth coin detection sensors; and

each of the fifth to seventh coin detection sensors has a function of obtaining a physical characteristic about a diameter of the coin that is moved on the carrying path.

6. The coin discrimination apparatus according to claim 1, wherein the coin detector further comprises fifth, sixth, and seventh coin detection sensors;

the physical characteristic about a diameter of a coin having a relatively small diameter is obtained by the fifth coin detection sensor;

the physical characteristic about a diameter of a coin having a relatively large diameter is obtained by the sixth coin detection sensor; and

the physical characteristic about a diameter of a coin having a relatively middle diameter is obtained by the seventh coin detection sensor.

7. The coin discrimination apparatus according to claim 2, wherein the coin detector further comprises fifth, sixth, and seventh coin detection sensors;

the physical characteristic about a diameter of a coin having a relatively small diameter is obtained by the fifth coin detection sensor;

the physical characteristic about a diameter of a coin having a relatively large diameter is obtained by the sixth coin detection sensor; and

the physical characteristic about a diameter of a coin having a relatively middle diameter is obtained by the seventh coin detection sensor.

8. A coin discrimination apparatus for receiving individual coins of different dimensions and physical characteristics from a source of a plurality of different coins comprising:

a coin separating and forwarding section for receiving and separating coins that are received in bulk and forwarding the separated coins in a controlled manner one after another to move along a carrying path;

a guide member formed along the carrying path to align each coin to be positioned and moved in a common orientation;

a coin discrimination section having a plurality of coin detection sensors operatively mounted along the guide member to sense each coin on the carrying path, wherein the coin discrimination section comprises:

a first coin detection sensor, a second coin detection sensor, a third coin detection sensor, and a fourth coin detection sensor;

wherein the first coin detection sensor, which is located adjacent the guide member, has a function of obtaining a physical characteristic of a thickness of a peripheral part of a coin that is moved on the carrying path,

the second coin detection sensor adjacent the guide member has a function of obtaining a physical characteristic of a material of a central part of the coin,

the third coin detection sensor adjacent the guide member has a function of obtaining a physical characteristic of a material of the peripheral part of the coin,

the fourth coin detection sensor adjacent the guide member has a function of obtaining a physical characteristic of a thickness of the central part of the coin, wherein the physical characteristics of the peripheral part of the coin can be determined from the outputs of the second and third coin detection sensors to determine a material and a decimeter of the peripheral part of the coin,

wherein each of the first to fourth coin detection sensors comprises a pair of magnetic material cores and coils wound respectively around the cores.

9. The coin discrimination apparatus according to claim 8, wherein the coin detector further comprises fifth, sixth, and seventh coin detection sensors;

the fifth coin detection sensor is located at a further position from the guide than the second and fourth coin detection sensors;

the sixth coin detection sensor is located at a further position from the guide than the fifth coin detection sensor;

the seventh coin detection sensor is located on the downstream side of the carrying path with respect to the fifth and sixth coin detection sensors; and

each of the fifth to seventh coin detection sensors has a function of obtaining a physical characteristic about a diameter of the coin that is moved on the carrying path.

* * * * *