



US 20120035026A1

(19) **United States**

(12) **Patent Application Publication**
Lyszczarz

(10) **Pub. No.: US 2012/0035026 A1**

(43) **Pub. Date: Feb. 9, 2012**

(54) **THREE-POINT ADJUSTMENT
MULTI-PURPOSE EXERCISE MACHINE**

Publication Classification

(76) Inventor: **Grzegorz Lyszczarz, London (CA)**

(51) **Int. Cl.**
A63B 21/062 (2006.01)

(21) Appl. No.: **13/275,355**

(52) **U.S. Cl.** **482/103**

(22) Filed: **Oct. 18, 2011**

(57) **ABSTRACT**

Related U.S. Application Data

(63) Continuation of application No. 12/185,919, filed on Aug. 5, 2008, now Pat. No. 8,057,368.

A multipurpose exercise machine requiring only three points of adjustment centrally located. It has a one point height adjustment and two adjustments for the rotating arm assemblies. Dip and chin up bars are attached to the arm assemblies. The machine contains an integrated swingable workout bench. Through the use of a pulley system and counter balance assembly, the cable system maintains tension and provides a constant length of cable.

(60) Provisional application No. 60/963,497, filed on Aug. 6, 2007.

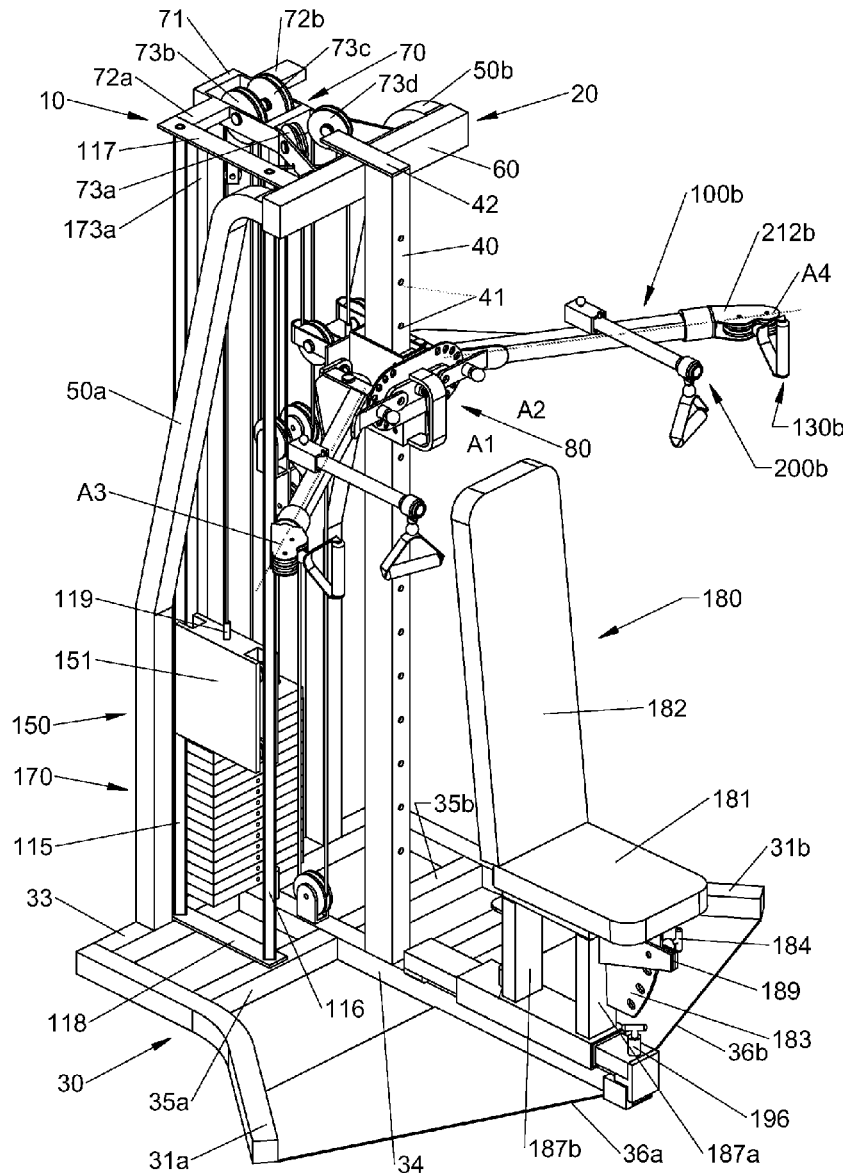

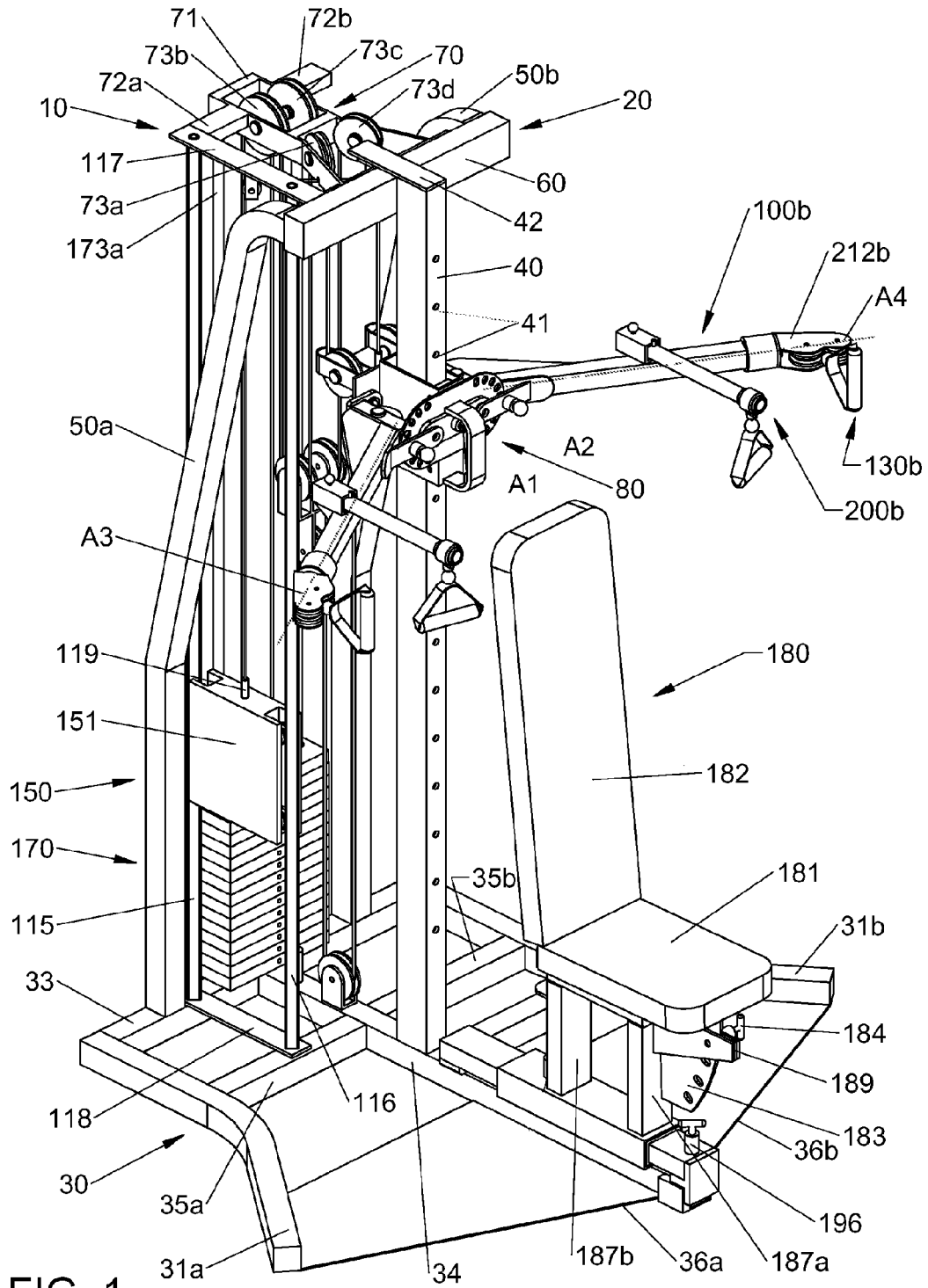

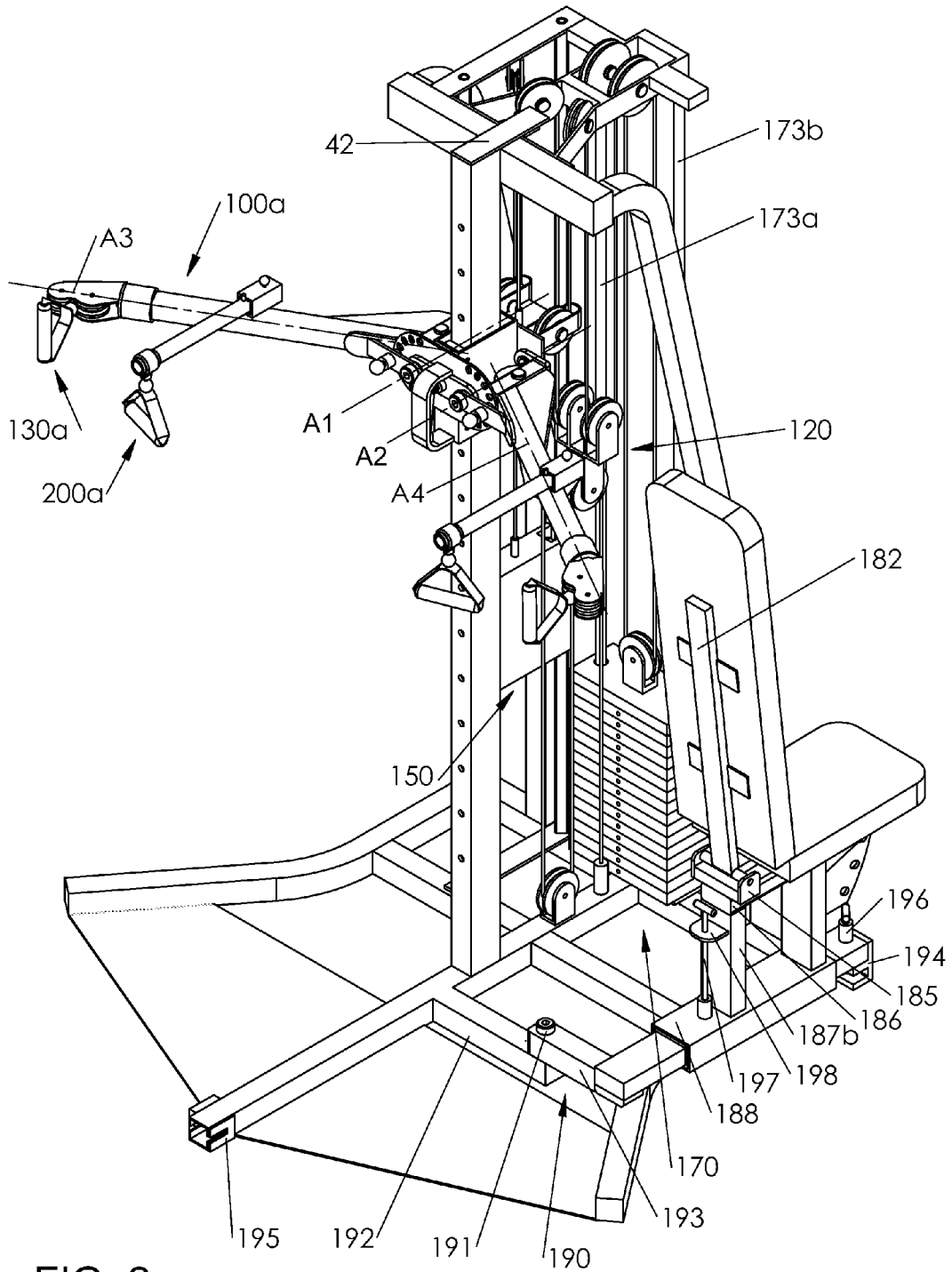

FIG. 2

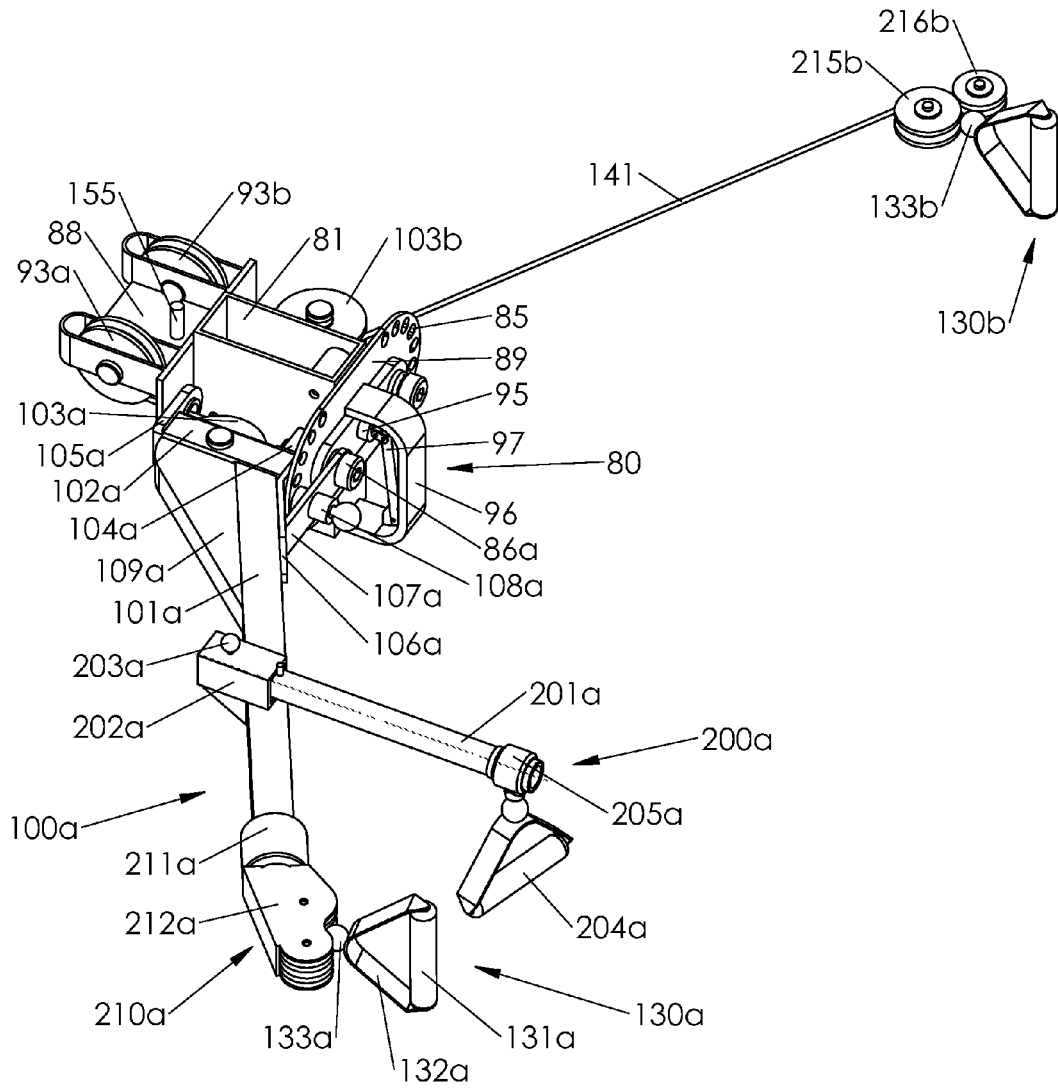

FIG. 3a

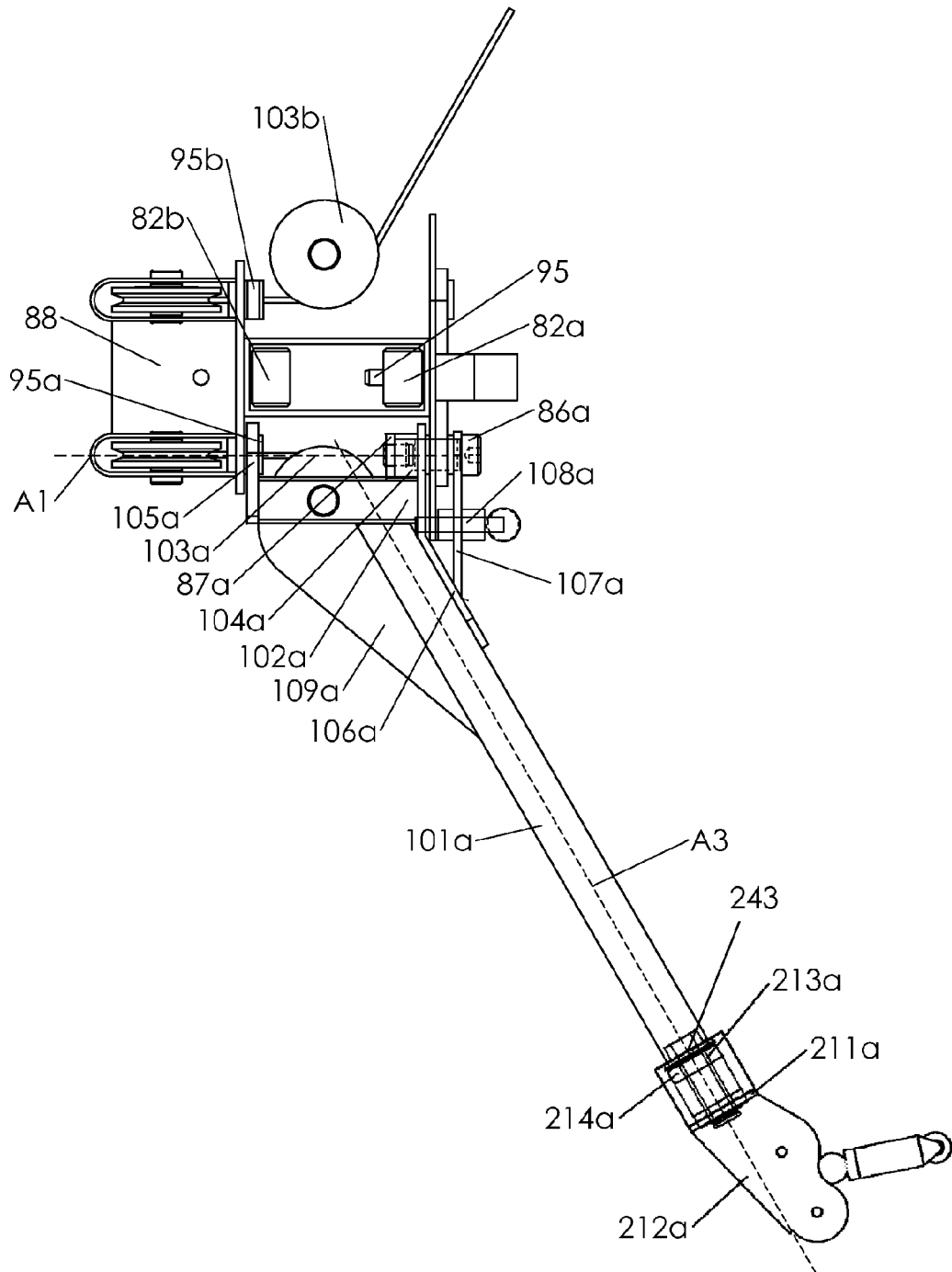

FIG. 3b

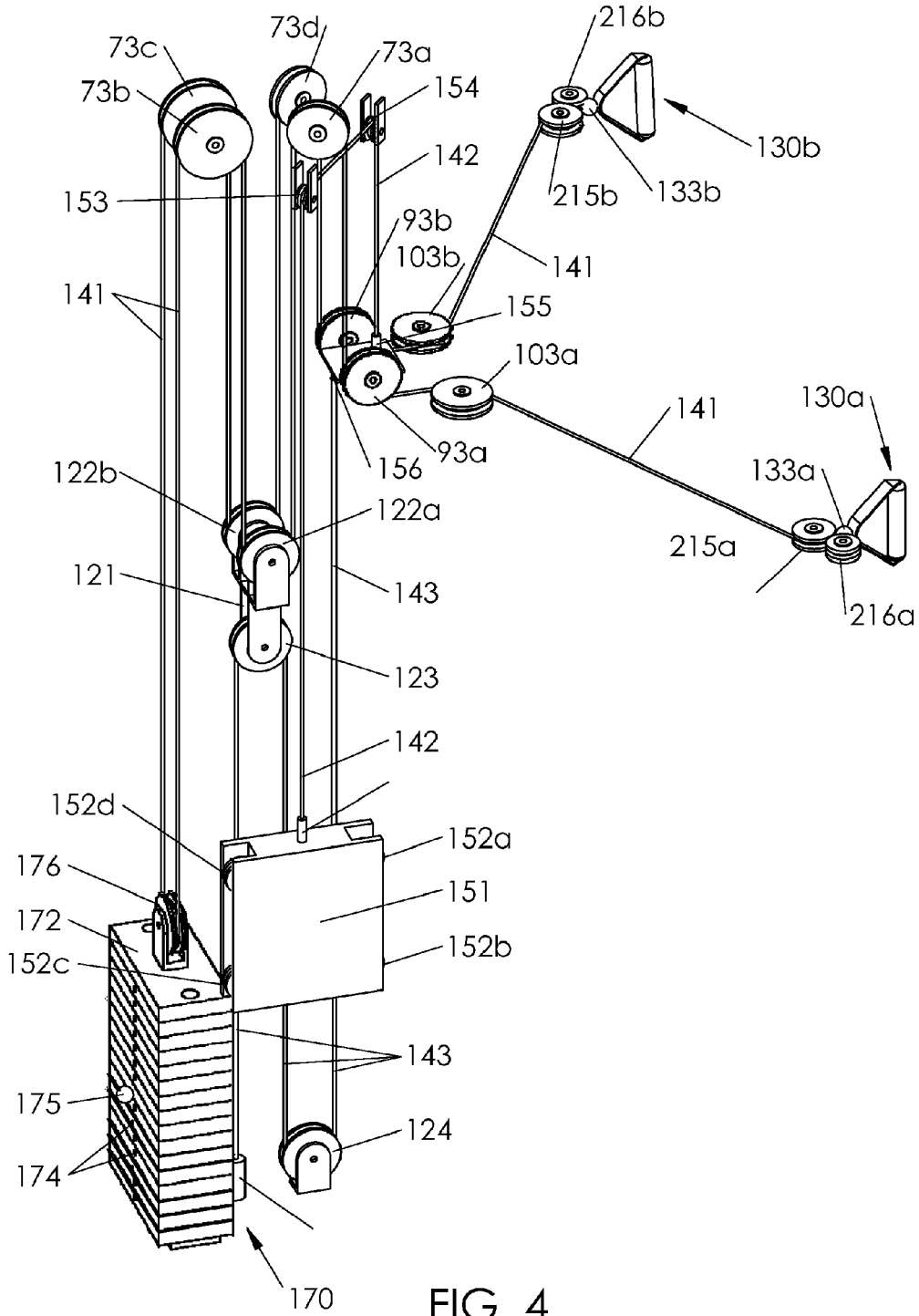

FIG. 4

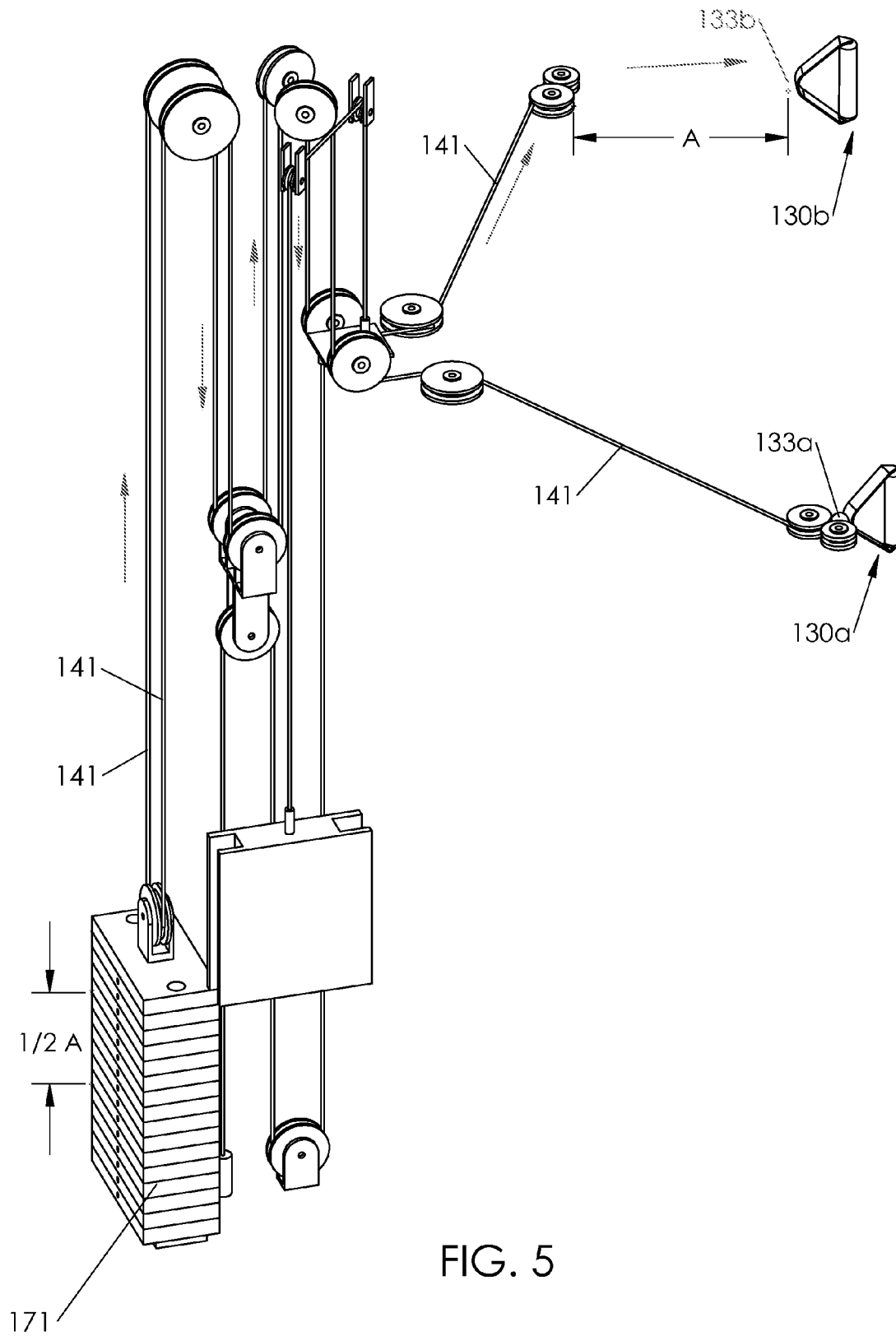

FIG. 5

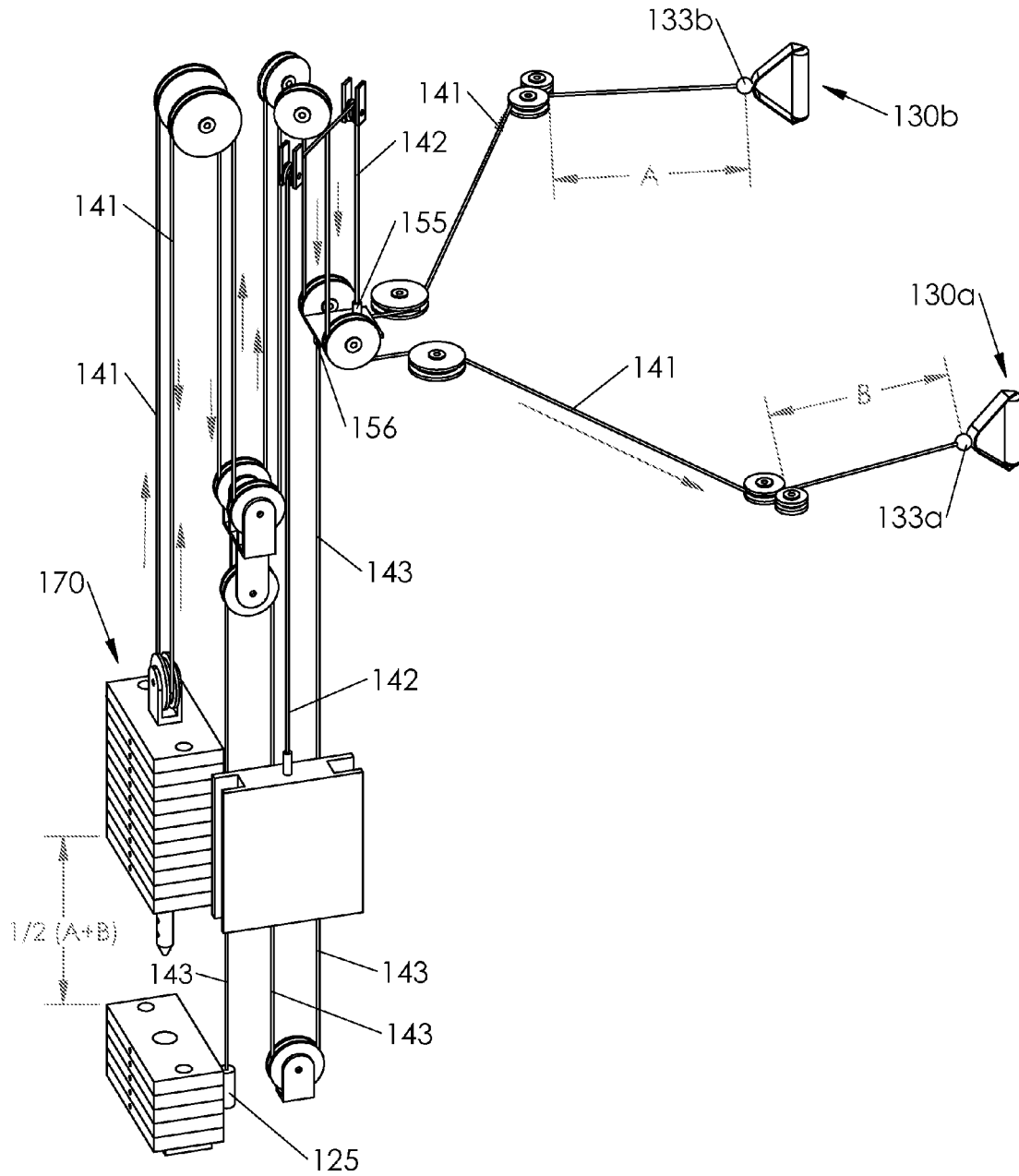

FIG. 6

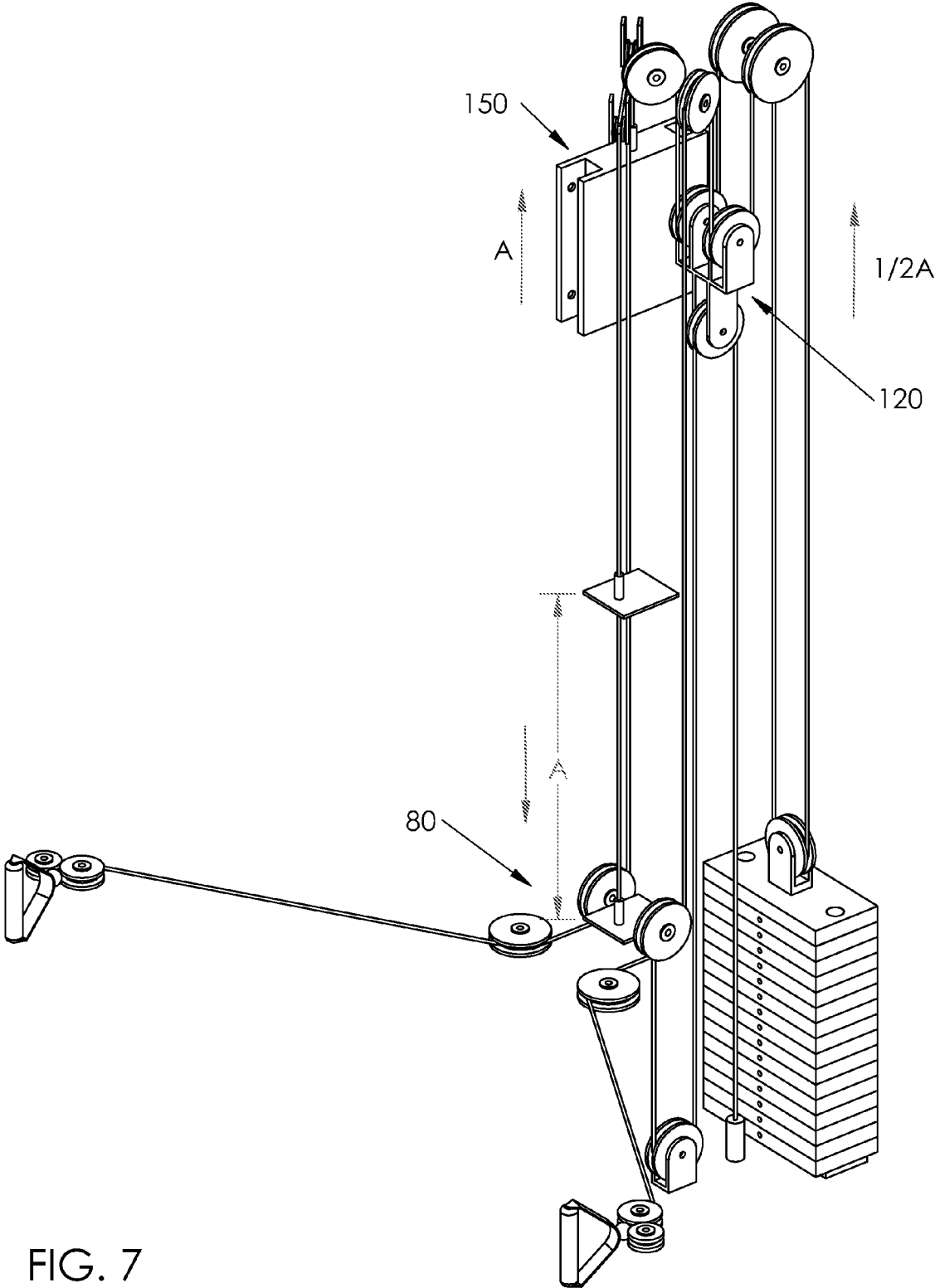

FIG. 7

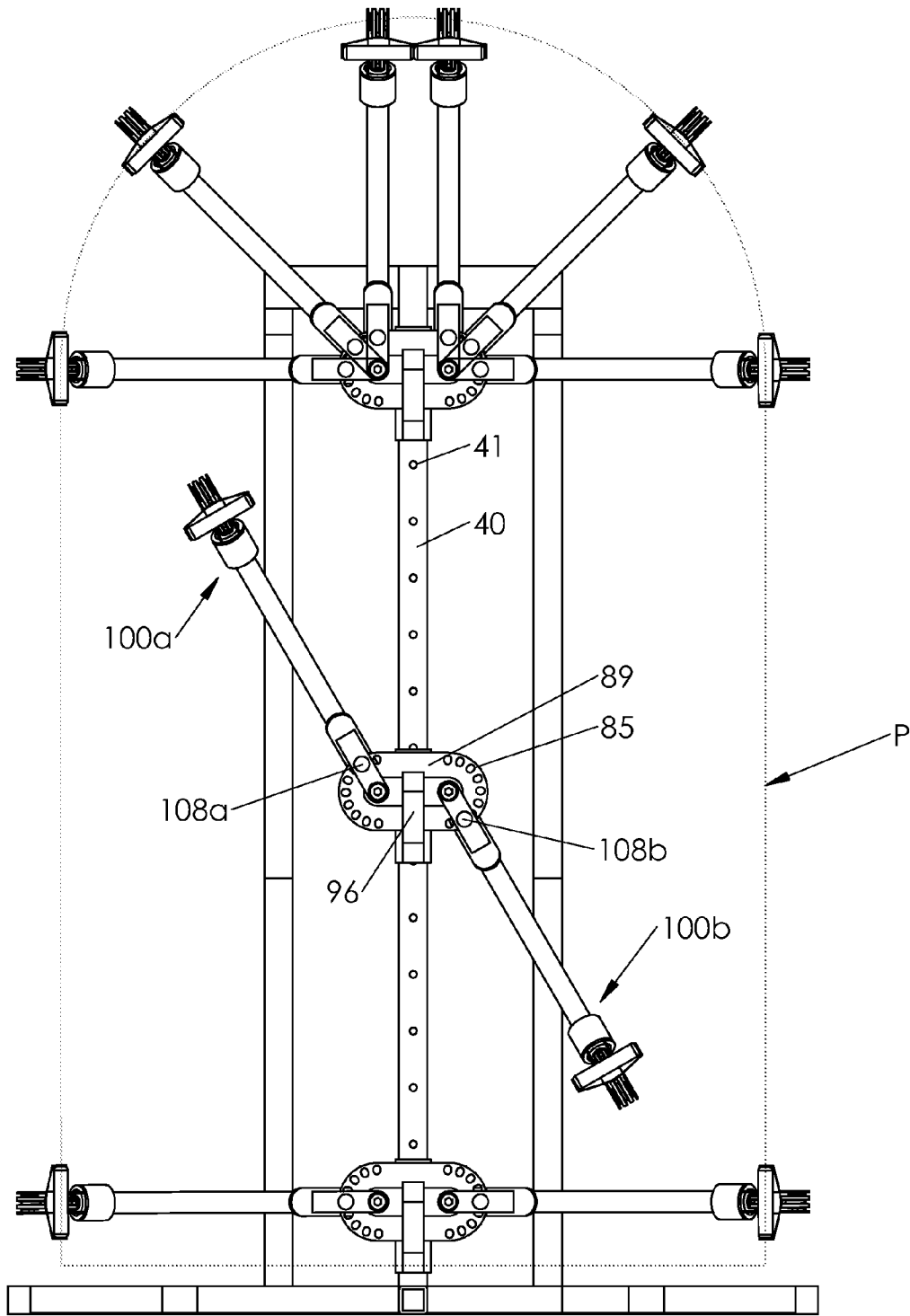

FIG. 8

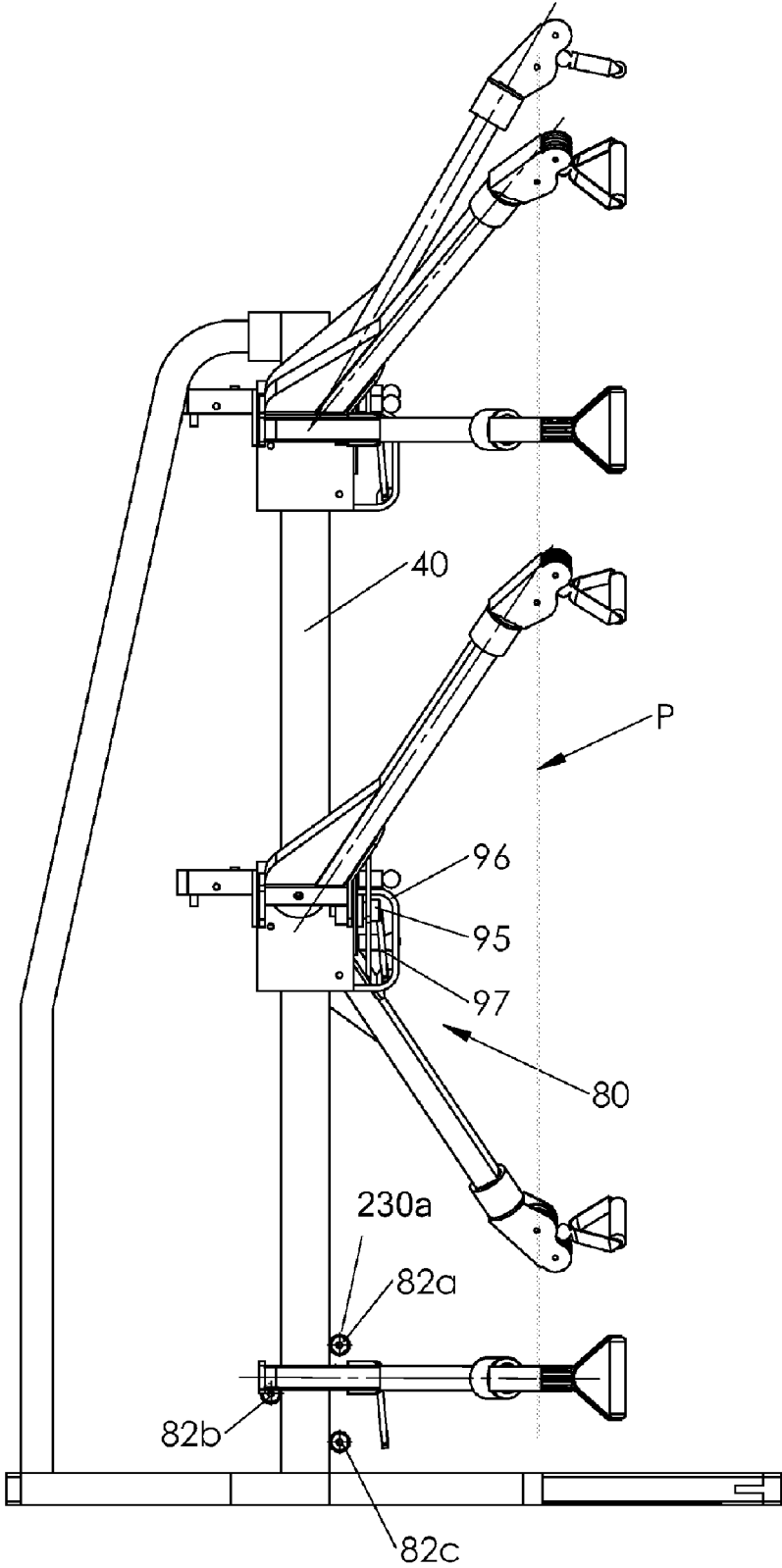
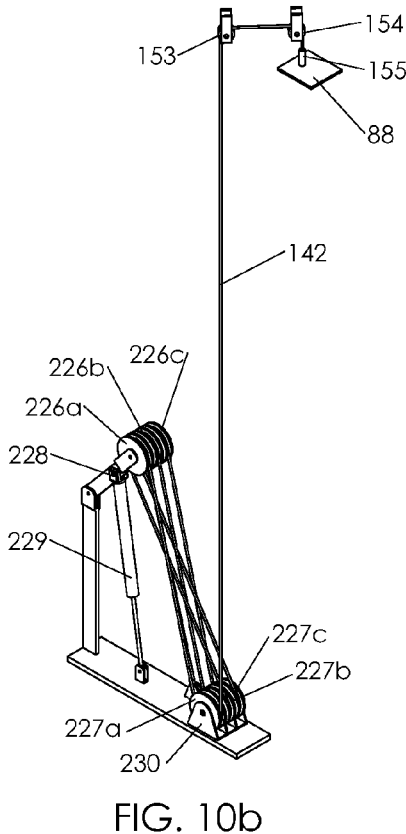
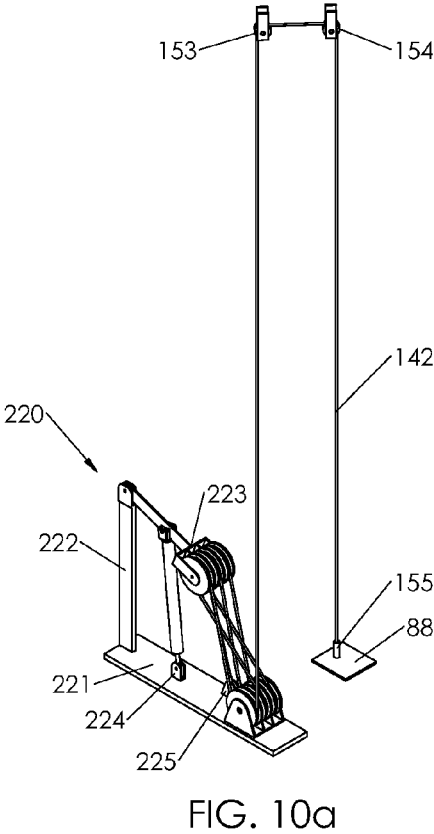

FIG. 9



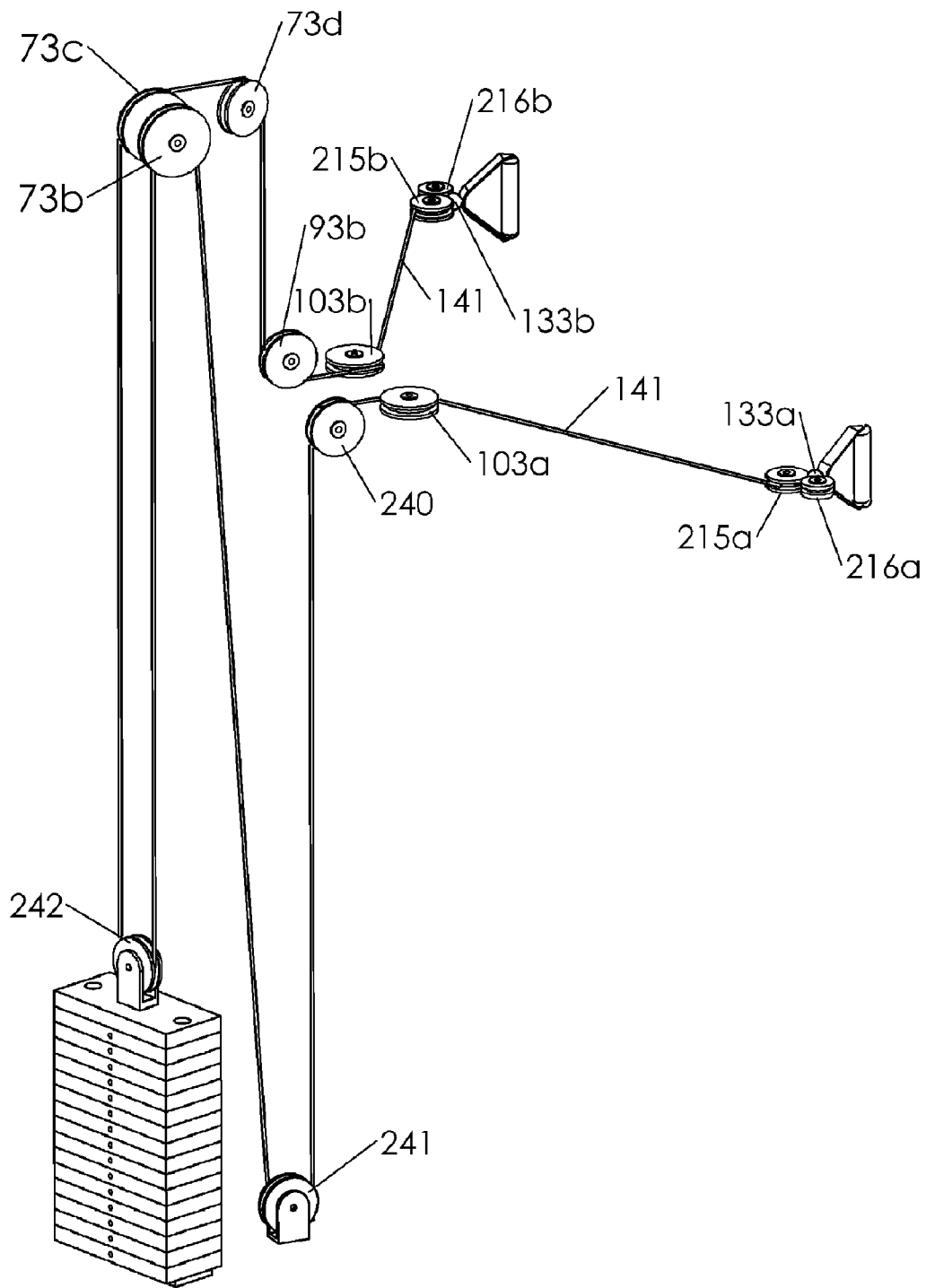

FIG.11

THREE-POINT ADJUSTMENT MULTI-PURPOSE EXERCISE MACHINE

CROSS REFERENCE TO RELATED APPLICATION(S)

[0001] The present application is a continuation of and claims the priority of U.S. patent application Ser. No. 12/185,919, filed on Aug. 5, 2008, which claims the priority of U.S. provisional patent application Ser. No. 60/963,497, filed on Aug. 6, 2007; and the present application claims the priority of both Ser. No. 12/185,919 and Ser. No. 60/963,497.

FIELD OF THE INVENTION

[0002] This invention relates to exercise machines, specifically multipurpose exercise machines used for strength, aerobic, stretching or rehabilitation exercises.

BACKGROUND OF THE INVENTION

[0003] Multi-functional weight training equipment which enables multiple exercise routines in various positions on a single machine has been designed in the past. Exercise devices that have been prevalent in recent years, commonly known as functional trainers, use adjustable components in order to create new positions for exercise. Thanks to their ability to transform themselves into different configurations, they can mimic most of the traditional multi-station machines and free weights with just a few adjustments. There are many types of functional trainers on the market today, and they use several different methods for adjusting their components. Most of them use adjustable arms, sliding carriages with pulleys or multiple pulleys mounted at different locations on the machine. Also, some of them can be used with the workout bench. The number of exercises that can be performed on particular machine depends on how many different configurations it can be transformed to. More configurations provide more exercise options for the user. The goal is to create as many new positions for exercise as possible with the use of a single machine. Recently there have been some attempts to incorporate the use of functional trainers with workout benches. This is a very desirable combination because it provides additional exercise options and with support of the bench, higher resistance can be used. There is a big demand for such versatile equipment, especially in the fast growing market of home gym fitness.

[0004] Unfortunately, the majority of these devices are large, cumbersome and difficult to handle. Some of them have limitations on positions available for exercise, and others have complicated and time consuming adjustments. Most of them lack versatility and are used only for strength exercises with one mode of resistance. Machines that combine a stationary bench with a functional trainer have limitations because the presence of the bench prohibits many exercises.

[0005] For example, U.S. Pat. No. 6,238,323, Nordic Track® 360° Home Gym, and Nordic Track® PT3 Trainer represent a group of functional trainers that use similar methods of adjusting their components to create new positions for exercise. They all use very long and stationary mounted adjustable arms that can rotate 180 degrees about a generally horizontal axis to different locked positions. These are adjusted such that their ends are very close together at the top and bottom of their arcs (arms in vertical position) and are widely spread when the arms are in the middle of their arcs (arms in horizontal position). The shortcoming of the

described method of adjustment is that there are limitations on the positions that their arms can take. More specifically they are not suitable for exercises that require the ends of the arms to be relatively close together and at about waist height of the exerciser (such as a typical rowing movement). Also, changing the height of the arms requires adjustments at two locations. Arms are very long (in order to provide for high and low pulley exercises) and awkward to handle. With the arms in a vertical position, there is not enough room in front of the machine for exercises that require pure vertical resistance (lat pull down, military press, squat) and user have to adjust their body position for these particular exercises, applying a vertical and an unnecessary horizontal force.

[0006] A different method for creating new positions for exercise is used in exercise machines presented in United States Patent Application Publication Numbers US 2003/0017918 A1 and US 2002/0013200 A1 (Known as Cybex FT360S) and commercially available Northern Lights Chilkat Cable Motion Trainer, Vectra VFT 100, Tuff Stuff MFT-700 and Paramount Functional Trainers Models PFT-200 and FT-150. With this method of adjusting the arms, narrow and wide grips at different heights are available, which greatly increases number of possible positions for exercise. Arms can rotate about a generally horizontal and vertical axis to different locked positions such that their ends move in three dimensional manners. Because of that the users are forced to move closer or further away from the machine for different exercises. For example, for exercises that require the ends of the arms to be relatively close together and at about waist height (such as a typical rowing movement) the distance between the user and the machine will be equal to the length of the arms.

[0007] The shortcomings of the described adjustment method are that three dimensional changes in the position of the very long arms require a lot of extra space, which is often not available. Three dimensional adjustments can be confusing, awkward and can intimidate new users or potential buyers. Creating new positions for exercise using three dimensional systems require adjustments at four locations, two for changing the height and two for changing the width of the arms which can be complicated and time consuming, especially for multiple consecutive users of different sizes (height).

[0008] The use of the bench with three dimensional arm positioning method requires changes of the bench position almost with every new arm location. Repositioning of the bench involves multiple lifting and can be time consuming and tiring.

[0009] Another method of adjusting components of the exercise machine to create new positions for exercise is presented in U.S. Pat. No. 6,447,430 B1, which shows the machine having two weight stacks, a pair of carriages mounted on the frame and adapted to be adjusted to different heights and pulley blocks on the carriages. Each of the pulley blocks are free to pivot about two axis of rotation so that the pulley blocks can follow the cables and remain aligned with the cables regardless of the direction in which the cables are pulled. The shortcomings of the machine described above are that the system is using complicated three dimensional adjustments of the arm position. Locations for adjustments are distant from each other and placed on two separate posts, forcing the user to walk between them to complete the desired changes, which can be time consuming. Height adjustment requires changes at two separate locations distant from each other. In order to change the height and the width, the user has

to complete a total of four adjustments at two separate locations distant from each other, which is complicated and time consuming. The machine has a large structure because it uses two posts for height adjustment and two separate weight stacks, which greatly adds to the weight of the entire assembly. Carriages are heavy to handle and placing them at the highest level is difficult because adjustment points are above the head of the average size user.

[0010] The arms of this machine swing in a horizontal plane, and because of that the maximum available height for exercise is limited by the height of the posts with the sliding carriages. Despite that the machine is built very tall, even at the highest position of the carriages, the highest position for exercise is at face level for the average sized user.

[0011] The machine is equipped with a dip bar and a chin up bar, but because they are installed at a fixed height they might be difficult to use for a below average size user. They provide only one fixed resistance equal to the body weight of the user, which might not be suitable for many beginner or intermediate level exercisers. Similar methods of adjustments as described in U.S. Pat. No. 6,447,430 B1 may be seen in machines like Body-Solid Functional Training Centre GDCC200, Northern Lights Functional Trainer, Pacific Fitness 3.23 Functional Trainer, Torque Fitness F5 and Life Fitness FSDAP.

[0012] Up to this time, there have been some attempts of combining machines that provide many exercise options by using the adjustability of their components with bench exercises. Combinations like this can provide exercises with more resistance from different locations and directions with user defined paths of exercise movements. Some machines have even added body weight exercises using dip bars, and/or a chin-up bar.

[0013] Examples of machines that combine a functional trainer with the use of a bench are for example Bowflex Revolution that provides machine with two arms that can rotate 180 degrees about a horizontal axis mounted at a fixed level behind a multi functional and adjustable exercise bench. Nordic Track® PT3 and Nordic Track® 360° Home Gym uses the same principals for arm adjustments like Bowflex Revolution but have higher mounted and longer arms and have a removable seat instead of a fold up bench.

[0014] Other examples are Body Craft mini/XPress and Body Craft XPress Pro which consist of two arms that can rotate 180 degrees and are mounted behind a seated exercise bench. Arms are much shorter (than Bowflex Revolution and PT3) and are located at a lower level. All of them use similar arm adjustment methods which does not provide positions for exercises that require starting points inside of the circle described by the ends of the arms. Specifically, the only available positions for exercise are located on the circumference of that circle. Therefore, the major shortcoming of these machines is the limitations on the positions that their arms can take. More specifically, they are not suitable for exercises that require narrow grip at about waist height for the exerciser (such as typical rowing movement). Also, the machines are relatively low for many standing exercises and because the arms are configured too close to the front of the machine there is not enough space for exercises that require pure vertical resistance. Despite that the bench folds up for storage it prevents the user from performing many user defined exercises, or these exercises must be done in awkward body positions.

[0015] Because their arms rotate generally in vertical plane, they do not provide enough room for exercises that require pure vertical resistance (squats, military press). In order to utilize those exercises, extra floor pulleys need to be used, or exercisers have to adjust their body positions to align with the angle of the cable.

[0016] Another shortcoming of these machines is that they do not economically use the length of the cable. This is mainly because the starting positions of many exercises that are often distant from the ends of the arms. Available cable length is reduced by the distance between the starting position for exercise and the ends of the arms.

[0017] The presence of the bench during exercises that do not require the use of the bench prohibits many exercises and many of them have to be performed in awkward positions. The removable seat of the PT3 machine does not provide enough adjustability. The arms of Body Craft mini/XPress do not provide for high pulley exercise and due to this, additional lat pull down assembly had to be added.

[0018] Body weight exercises are very popular, effective and are often recommended as an additional variation in anybody's workout routine. Prior art machines have been designed in the past that incorporate dip bars and chin up bars as sub-assemblies built into a main structure of a multi-purpose exercise machine. Usually they are built as an addition to the entire structure or in the form of a fold up design.

[0019] Shortcomings of such an arrangement are that it increases the size and the cost of the unit, beside that, most of the prior art dip bars and chin up bar assemblies are installed at fixed heights and they might be difficult to use for a below average size user. Also, they provide one fixed resistance equal to the body weight of the user which might not be suitable for many beginner or intermediate level exercises.

SUMMARY OF THE INVENTION

[0020] A 3 point arm adjustment multipurpose exercise machine is disclosed which provides a very effective method of creating new positions for exercise. The new machine can provide different height positions for arm exercises combined with different configurations of the adjustable arms providing multiple widths for low and high pulley exercises as well as multiple heights for narrow and wide grip exercises. All of the prior art machines require adjustments at four locations (points) to achieve a similar number of positions available for exercise.

[0021] One point height adjustment with unchanged configuration of arms greatly shortens transition time between exercises and can simplify more complex workout routines, such as circuit training. With one point height adjustment, exerciser can switch in seconds from low to mid or even high pulley exercises which with prior art, equipment would require at least two separate adjustments.

[0022] The present machine provides a very simple adjustment system, which makes all the adjustments for new positions for exercise easily predictable by the exerciser and it greatly simplifies the use of the bench which does not need to be moved to fit new arm positions.

[0023] Arms adjustments can be made with three adjustment points placed at one convenient location. High pulley level can be adjusted by each exerciser to meet their individual needs. With the presented adjustment method for creating new positions for exercise, handles at the ends of arms can be brought within a view inches from the starting position for exercise which allows for greater economical use avail-

able for exercise cable length. This ability can be used and appreciated in the fields of rehabilitation and physiotherapy where precise positioning, proper form and execution of the path of the exercise is very important.

[0024] Another advantage of the present invention is that it offers a wide range of bench exercises as well as freeing space when bench is not needed. The bench can swing from the storage position to exercise position.

[0025] The present invention may have one or more of the following advantages: It has a reduced number of adjustment points; it has new uses for traditional components; it is more versatile; it has simpler, faster, easier to handle and accessible from one location adjustments; it has a one point height adjustment; it offers full range of undisturbed bench or functional exercises without sacrificing their proper form; one adjustable structure can be used for different types of workout and with different modes of resistance; various lifting or pulling exercises that require pure vertical resistance can be performed without additional attachments or changing of the body position of the exerciser; provides multiple positions and adjustable resistance for body weight exercises; can be used with at least one swing-away workout station; and it has more economical use of the cable length.

BRIEF DESCRIPTION OF THE DRAWINGS

[0026] The accompanying figures depict and disclose examples of the invention and examples of various positions and uses of the invention wherein:

[0027] FIG. 1 is a front right perspective view of an embodiment of the exercise machine of the present invention, with the arms in a generally horizontal position;

[0028] FIG. 2 is a front left perspective view of the exercise machine with the swing away workout station in a generally retracted position;

[0029] FIG. 3a is a perspective view of the carriage with one arm hidden, showing carriage components in greater detail;

[0030] FIG. 3b is a top view of the carriage with one arm hidden, showing arm mountings, bushings and carriage rollers along the handle pulley assembly showing components in greater detail;

[0031] FIG. 4 is a schematic view of the cabling independent of the frame and arm structures where the handles of both arms are not pulled out from the ends of the arms;

[0032] FIG. 5 is a schematic view of the cabling independent of the frame and arm structures where the handle of one arm is pulled out and the handle of the other arm is not pulled out and with the weight selected is raised to half of the distance the handle is pulled;

[0033] FIG. 6 is a schematic view of the cabling independent of the frame and arm structures where the handles of both arms are pulled out from the ends of the arms with the weight selected raised to half of the combined distance the handles are pulled;

[0034] FIG. 7 is a schematic view of a simplified carriage and arm assembly in a lower position on the centre post with a counterbalance and cable compensator adjusted accordingly;

[0035] FIG. 8 and FIG. 9 are front and right side views, respectively, of the exercise machine with multiple carriage positions and configurations shown to illustrate the plane of possible exercises;

[0036] FIG. 10a and FIG. 10b is a schematic of an alternative counter balance assembly;

[0037] FIG. 11 is an alternative embodiment for maintaining tension and a constant length of cable available for exercise.

DETAILED DESCRIPTION OF THE INVENTION

[0038] The present invention will now be described more fully, in which preferred embodiments of the invention are shown. The disclosed embodiment is merely exemplary of the invention, which may be embodied in various forms. Therefore the details disclosed herein are not to be interpreted as limited, but merely as the basis for the claims and as a basis for teaching one skilled in the art how to make and/or use the invention.

[0039] With reference to FIG. 1, from the view point of the exerciser sitting on bench assembly 180 with back resting on the back support 182, the assemblies and components on the “right” side of the exercise machine 10 will be denoted by suffix “a”, and the “left” side of the exercise machine 10 will be denoted by suffix “b”.

[0040] With reference to FIG. 1 and FIG. 2, a multipurpose exercise machine 10 is disclosed. The exercise machine 10 further includes major features, namely, an upstanding frame 20, a carriage and arm assembly 80 with two rotating arm assemblies 100a, 100b, a pair of handle units 130a, 130b, a pair of adjustable chin-up and dip bar assemblies 200a, 200b, a counterbalance assembly 150, a cable length compensator assembly 120, a weight stack assembly 170, and a swing away workout station 190.

[0041] The frame further consists of a base 30, a vertical centre-post 40, two vertical support posts 50a, 50b, an upper frame reinforcement 60, and an upper pulley assembly 70.

[0042] The base 30 further consists of two side members 31a, 31b connected via cross member 33. Base plate 36a and 36b is connected to two side members 31a and 31b. The central reinforcement 34 is connected at the midpoint of cross member 33. Two small cross members 35a, 35b are connected in line and in between side members 31a, 31b. The lower end of vertical centre post 40 is connected to central reinforcement 34 and its upper end is attached to the midpoint of the upper frame reinforcement 60. Both ends of the upper frame reinforcement 60 are connected to the second ends of the vertical support posts 50a, 50b. The first ends of the vertical supports 50a, 50b are mounted to the cross member 33.

[0043] Referring to FIG. 1, upper pulley assembly 70 comprising a pulley mount 71, guide rod mounting brackets 72a, 72b, and pulleys 73a, 73b, 73c, 73d which are mounted via bolts to the pulley mount 71.

[0044] Referring to FIG. 1, 4, counter balance assembly 150 will be described. The counter balance assembly 150 comprising a counter weight 151 with guide rollers 152a, 152b, 152c, 152d operatively connected with guide rails 115, 116. Guide rails 115, 116 are positioned vertically and parallel to each other. Upper and lower reinforcements 117, 118 mount together guide rails 115, 116 at the lower end to the small cross member 35a and cross member 33, and to upper reinforcement 60 and guide rail mounting bracket 72a at the upper end. Cable anchor 119 connects the first end of cable 142 to the counter weight 151. Cable 142 extends over transfer pulleys 153, 154 and connects via cable anchor 155 to the upper surface of pulley mount 88 of carriage and arm assembly 80 (FIG. 3a). Counterbalance cable 142 interconnects counter weight 151 with carriage and arm assembly 80.

[0045] Referring now to FIG. 1, 2, 4, 5. The weight stack assembly 170 which is mounted on cross member 33, comprising an operating rod 171, a weight stack pulley 173 connected to the operating rod 171, a plurality of weight plates 172 which are mounted on guide rods 173a, 173b with their bottom ends mounted on cross member 33. Operating rod 171 and weight plates 172 have aligned openings 174 through which a pin 175 can be inserted to connect any of the weight plates 172 to operating rod 171. When a given weight plate 172 is connected to operating rod 171, that plate and any plates above it will be lifted with the operating rod 171.

[0046] The upper ends of the guide rods 173a, 173b of weight stack assembly 170 are attached to brackets 72a, 72b of the second end of upper pulley assembly 70. The first end of upper pulley assembly 70 is attached to the midsection of upper reinforcement 60.

[0047] Those skilled in this art will recognize that although a weight stack is the preferred structure for providing resistance to the exerciser, other resistance-imparting structures such as friction-imparting devices, variable viscosity devices, air drag-based resistance devices, pneumatic devices, elastically bending rods, gas springs, magnetic devices, hydraulic devices, and the like, may also be employed with an exercise machine of the present invention.

[0048] Referring to FIG. 3a, 3b, 9, the carriage and arm assembly 80 comprising a sleeve 81 with rollers 82a, 82b, 82c (FIG. 9), bolt 230a, arm selector plate 89 and pulley mount 88. Sleeve 81 and rollers 82a, 82b, 82c are operatively connected via bolts. Rollers 82a, 82b, 82c are positioned and sized to provide for rolling operation between carriage and arm assembly 80 over the vertical centre post 40. Arm selector plate 89 with both ends semicircular in shape includes near its perimeter a series of position apertures 85 arranged in a semi-circle at circumferential increments of 22.5 degrees, although other increments are also suitable. Circular holes (where bolt 86a is inserted) in the arm selector plate 89 are coincident with the holes in the pulley mount 88 and axis A1 to provide mounting and rotation points for arm assembly 100a about the axis A1. The centre of the semi-circle defined by the apertures 85 is also coincident with axis A1. Cable anchors 155 and 156 (FIG. 4) are mounted on the top and bottom of the horizontal plate of the pulley mount 88. Pulleys 93a, 93b, are attached via bolts to the pulley mount 88. The axis of rotation of pulleys 93a, 93b are perpendicular to axis A1 and positioned such that the axis of the cable 141 when engaged with pulleys 103a, 103b, coincides with axis A1. In this arrangement, rotation of the arm assembly 100a about axis A1 does not change tension in the cable 141. A carriage selector pin 95 is operatively connected with handle 96 via linkage 97 and spring (not shown). Insertion of carriage selector pin 95 into one of the height position apertures 41 in the centre post 40 prevents vertical movement of the carriage and arm assembly 80. The carriage and arm assembly 80 may be locked in any position along the vertical centre post 40 and such locked positions may be of any size (4 inches shown).

[0049] The arm assemblies 100a, 100b are mirror images of one another about a vertical plane as shown in FIG. 3a that extends through the centre of the carriage and arm assembly 80. In the interest of clarity and brevity, only one arm assembly 100a will be described in detail herein; those skilled in this art will appreciate that this discussion is applicable to the arm assembly 100b.

[0050] Referring now to FIG. 3a, 3b, the arm assembly 100a further includes arm 101a with arm reinforcement 109a

connected at its mounted end to the arm mounting bracket 102a consisting of front and rear supports 104a, 105a, respectively, pulley 103a rotatably mounted between them, a front reinforcement 106a, and a bracket 107a with spring loaded arm selector pin 108a. The centre of the circular holes in the front support 104a, rear supports 105a, front reinforcement 106a, and the unattached end of bracket 107a are coincident with axis A1 (FIG. 1, 2) and provide mounting and rotation points for the arm assembly 100a about axis A1. The spring loaded arm selector pin 108a is mounted in the midsection of the bracket 107a and the pin is sized and configured such that in its extended position can be received in one of the position apertures 85 and in the openings of the front reinforcement 106a. Insertion of the pin into one of the position apertures 85 and opening in the front reinforcement 106a, prevents rotation of the arm assembly 100a about the axis A1. Retracting the pin 107a from one of the position apertures 85 and openings in the front reinforcement 106a makes rotation of the arm assembly 100a about axis A1 possible.

[0051] Arm assembly 100a is rotatably mounted with the carriage and arm assembly 80 about axis A1 (FIG. 1, 2) via bolt 86a at the front end and sleeve bushing 95a at the rear end. Locking nut 87a secures the connection and enables adjustment of the rotational resistance by tensioning of nut 87a and bolt 86a.

[0052] As shown in FIG. 1, 2, the arms extend forward at a chosen angle from a pivot point located on the carriage and arm assembly 80. FIG. 9 shows the arms angled at 30° from the vertical, but those skilled in the art will recognize that any practical purposely chosen angle can be applied without departing from the spirit of the invention. That is, the arms are angled forward to provide enough space for performing standing or seated exercises when a pure vertical resistance is required to deliver proper exercise form in exercises such as shoulder presses or standing squats.

[0053] Referring to FIG. 1, 2, 3a, 3b, removable chin-up and dip bar assemblies 200a, 200b are attached at the mid-section of arm assemblies 100a, 100b respectively. Bar assembly 200a comprising a bar 201a and sleeve 202a which are fixed to the mid-section of the arm 100a. Bar 201a can be removed or attached to the arm 100a using pin 203a, connecting sleeve 202a with bar 201a. Bars are in a generally horizontal position and can be adjusted to various widths by rotating arm assemblies 100a, 100b about axis A1, A2 and securing with selector pin 108a to the selector plate 89. The height of the bars 200a, 200b can also be adjusted by changing height of the carriage and arm assembly 80 and securing with height selector pin 95. Handle straps 204a or other attachments can be attached to the rotatable connection 205a at the end of the bar 201a to provide for more exercise options. This adjustable arrangement can accommodate exercisers of different sizes and fitness levels. Intensity of the exercise can be changed by changing the height or the width of the bars and/or attachments.

[0054] Bars 200a, 200b eliminate the need for specially designated chin-up or dip stations which are achieved here without changing the size of the machine and using the same adjustable structure for several different applications.

[0055] Referring still to FIG. 3a, 3b, the arm assembly 100a also includes pulley assembly 210a comprising bearing sleeve 211a with pulley housing 212a, which is rotatably mounted over the hollow shaft 213a, attached to the arm 101a, such that it is free to rotate relative to the arm 101a about axis A3 (parallel with the longitudinal axis of the arm

101a). At least one bearing 214a, although two are shown with the present invention, are mounted such that the outer ring is attached to the sleeve 211a and an inner ring attached to the hollow shaft 213a and secured with external snap rings, such as external snap ring 243, shown in FIG. 3b (other external snap ring(s) not shown) at the end of the hollow shaft 213a. Two pulleys 215a, 215b (FIG. 4) are rotatably mounted with bolts inside pulley housing 212a, and positioned so that they permit passage of the cable between them. Pulley 215a is mounted such that axis of rotation A3 is coincident with the axis of the cable 141 when engaged with the pulley 215a. Pulley 216a is preferably smaller than pulley 215a and is positioned such that it engages with the cable 141 when the applied pulling angle of cable 141 can no longer be supported by pulley 215a. Pulleys 215a, 216a always guarantee cable engagement at most commonly used angles for a particular exercise.

[0056] Referring now to FIG. 3a, the handle unit 130a will be described with the understanding that the description is equally applicable to the handle unit 130b. The handle unit 130a includes handle 131a, flexible strap 132a attached to each end of handle 131a and formed into a loop and stopper 133a that is fitted over strap 132a and attached to the end of cable 141. From this position it can be grasped by an exerciser, and when pulled will cause rotation of pulley assembly 210a about axis A3 (FIG. 1, 2) and allow the direction of the cable to align with the direction of the pulling force exerted by the exerciser via handle unit 130a. Different handle attachments can be used with present invention, for example, different lengths of soft single grip handles, ankle straps, horse shoe handles, rope attachments and different types of pull down bars.

[0057] Referring now to FIG. 1, 2 the swing-away bench assembly will be described. Those skilled in the art will understand that the described bench is an example of a workout station which can be used with the present invention and that the subject of the invention is the method of bringing the workout station to the exercise position and removal of the entire station (not partial) to the storage position.

[0058] Referring now to FIG. 1, 2 bench assembly 180 will be described. Bench assembly 180 comprising seat 181 coupled with back support 182 at the pivot bracket 185 which is mounted on seat support 186. Two vertical supports 187a, 187b are attached to the seat support 186 at the top end and to the sliding sleeve 188 at the bottom end. Tilt selector plate 183 with tilt selector pin 184 attached to selector bracket 189 is mounted at the front of the vertical support 187a. Slide selector pin 197 is attached to sliding sleeve 188 and guided by holding bracket 198 attached to vertical support 187b. Bench assembly 180 allows for angular adjustment of seat 181 and back support 182 about pivot bracket 185 using tilt selector pin 184 inserted retractably in one of the openings in tilt selector plate 183. Depth adjustment of the bench assembly 180 is also provided and can be accomplished by changing position of sliding sleeve 188 mounted over swing able arm 193. Position of sliding sleeve 188 can be selected and secured with retractably mounted slide selector pin 197 inserted in one of the selector holes (not shown) in the swing-able arm 193.

[0059] Described above bench assembly 180 is just an exemplary workout station that can be utilized with present invention and is used to describe a concept of creating an actual multi station exercise machine by bringing in specific workout stations that can be stored at both sides of the

machine from storage position to the exercise position and use them as a regular stationary workout station, for example, bench press exercises can be done with bench assembly 180 in workout position (FIG. 1) or with bench assembly 180 swung to storage position (FIG. 2) and the freed space in front of the machine can be utilized for a number of undisturbed functional exercises (FIG. 8, 9).

[0060] Those skilled in this art will appreciate that the described above bench assembly 180 is just one of many possible types of workout benches that can be used with the present invention and can be stored on either sides and is used here as an example to explain the concept and method of creating combined multi-station exercise machine and functional trainer all in one without increasing space requirement and using just the original footprint of the present invention. Almost any commonly used types of exercise benches or stationary attachments can be used with present invention including benches with leg extension attachment, fold-up type benches with adjustable and removable back support and rowing capability.

[0061] Referring now to FIG. 1, 2 when bench assembly 180 (or any other suitable bench) is connected to a swing able arm 193 it creates swing-away workout station 190, comprising entire bench assembly 180 connected to the swing able arm 193 with sleeve 188. Bench assembly 180 can also be connected with swing able arm 193 with bolts, welts, or clamps and those skilled in this art will appreciate that the sleeve connection is just an example to better explain the concept of present invention and shouldn't be limited to such. Swing-away workout station 190 further comprising pivot pin 191 connecting swing able arm 193 with one end of the stationary mount 192 which is attached to the central reinforcement 34 at the other end. Swing able arm 193 can be locked at the workout position with retractable locking pin 196 connecting lock 194 located at the end of the swing able arm 193 to the stationary lock receiver 195 located at the end of the central reinforcement 34. With locking pin 196 retracted, swing-away workout station 190 can be moved to storage position on the side of the present invention. The pivotal connection between stationary mount 192 and swing able arm 193 via pivot pin 191 provides a delivery system for most benches or workout stations that when attached to the swing able arm 193 can be brought to workout position (FIG. 1) or from workout position to storage position (FIG. 2). The described above components of the delivery system are designed so that swing able workout station 190 when moved to or from workout position, rarely interferes with arms 100a, 100b and when in workout position there is still enough room provided for most of the adjustments of arms 100a, 100b and carriage and arm assembly 80 needed for different exercises.

Operation

[0062] Referring now to FIG. 1, 2, 4 the operation of the present invention will now be described. Single cable 141 couples both of the handle units 130a, 130b with the weight stack assembly 170. Cable 141 extends from the handle unit 130a, in between pulleys 216a, 215a through bearing sleeve 211a coincident with axis A1, through arm 101a, and engages with pulley 103a mounted between front and rear supports 104a, 105a of the arm mounting bracket 102a. Cable 141 passes through sleeve bushing 95a, coincident with axis A1 and engages with pulley 93a mounted at the pulley mount 88 of carriage and arm assembly 80. Pulley 93a can be moved vertically (up or down) with the carriage and arm assembly 80

without changing the tension in cable 141. Cable 141 then travels upwardly and engages and passes over right front pulley 73a of the upper pulley assembly 70. After passing pulley 73a, cable 141 travels downwardly, engages and passes below pulley 122a of cable compensator assembly 120. The cable then travels upwardly and passes over right rear pulley 72a of the upper pulley assembly 70. From there, the cable 141 travels downwardly, engages, and passes below weight stack pulley 173 and travels upwardly to the left rear pulley 72b of the upper pulley assembly 70. Cable 141 then passes over pulley 72b and travels downwardly, engages, and passes below upper left compensator pulley 122b of cable compensator assembly 120. Cable 141 then travels upwardly, engages, and passes over left front pulley 73b of the upper pulley assembly 70. Cable 141 then travels downwardly, engages, and passes below pulley 93b mounted at pulley mount 88 of carriage and arm assembly 80. Pulley 93b can travel vertically (up or down) with carriage and arm assembly 80 without changing the tension of cable 141. Cable 141 then travels along axis A2, engages with pulley 103b, and travels along axis A4 of arm 100b. Cable 141 extends through pulley housing 212b between pulleys 215b, 216b and terminates at handle 130b.

[0063] FIG. 5, 6 show one of the selected positions for exercise. The exerciser can grasp one or both of the handle units 130a, 130b, and pull them away from the ends of arms 100a, 100b. The grasping can be accomplished by one or both of the exerciser's hands or feet as desired for the given exercise. The respective ends of cable 141 are provided with stoppers 133a, 133b. As those skilled in the art will readily appreciate that stoppers 133a, 133b control the motion of cable 141 to allow exercise by pulling one end of the cable separately or both ends at the same time. FIG. 5 illustrates the use of just one handle unit 130b. When one end of the cable 141 is pulled at the handle unit 130b the second end is anchored at the stopper 133a. Force exerted at handle unit 130b transfers through cable 141 to weight stack assembly 170 and causes the selected weight to rise. In the event that only one hand or foot is used the illustrated arrangement of the pulleys reduces the selected resistance by fifty percent. (e.g. For each ten pounds of weight selected, the exerciser experiences five pounds of resistance.) And for every distance traveled by the end of the cable 141, weight stack assembly 170 will travel half of that distance (marked as A and $\frac{1}{2}A$ in FIG. 5).

[0064] In the event that both handles 130a, 130b are used at the same time, handle units 130a, 130b are engaged and pulled away from their respective arms 100a, 100b. When the exerciser uses both hands or feet, the arrangement of the pulley train transfers one hundred percent of the pre-selected resistance at weight stack 170 to handle units 130a, 130b. (e.g. For each ten pounds of weight selected, the exerciser experiences ten pounds of total resistance typically five pounds in each handle unit 130a, 130b.) FIG. 6 shows an example when both handles are used at the same time. When handle units 130a, 130b are pulled at different distances, than the distance travelled by the weight stack is equal to $\frac{1}{2}(A+B)$, where A and B are the distances travelled by handle units 130a, 130b, respectively. When the distance travelled by the handle units 130a, 130b is equal (distance A equal distance B) the distance travelled by the weight stack is equal to the distance travelled by one of the handles.

[0065] Normally vertical adjustment of the carriage and arm assembly 80 would change tension in cable 141 and the

length of cable available for exercise. Cable compensator assembly 120 is used to maintain the tension in cable 141 and a constant length of cable available for the exercise. Cable 141 at its midsection creates a downward U-shape loop between pulleys 73a, 73b, 72a, 72b at the top and engages with pulleys 122a, 122b of the cable compensator assembly 120 at the bottom of the loop. Cable compensator assembly 120 interconnects cable 141 with anchor cable 143 via pulleys 122a, 122b, 123 rotatably mounted to bracket 121. Anchor cable 143 interconnects carriage and arm assembly 80 via pulleys 124, 123 and cable anchor 125, with frame member 34. Cable 141 and anchor cable 143 interact together via cable compensator assembly 120. When carriage and arm assembly 80 is moved upward or downward from any location on vertical post 40, cable compensator assembly 120 travels in the opposite direction and one half of the distance traveled by the carriage and arm assembly 80. Anchor cable 143 anchors cable compensator assembly 120 in fixed position at any pre-selected height of the carriage and arm assembly 80 and enables cable 141 to transfer resistance from weight stack 170 (source of resistance) to the handle units 130a, 130b used by exerciser. Cable compensator assembly 120 compensates both halves of cable 141 at the same time without changing the tension or length of the cable available for exercise.

[0066] Referring now to FIG. 11 the alternative embodiment for maintaining tension and a constant length of cable available for exercise will be described. Cable 141, anchored between pulley 215a, 216a with a stopper 133a at one end, extends along axis A3 and engages pulley 103a. It travels along axis A1 over the top of pulley 240, travels downwardly and engages and passes below pulley 241. Cable 141 then travels upwardly and engages and passes over the right rear pulley 72a and extends downwardly passing below the weight stack pulley 173 and travels upwardly to the left rear pulley 72b. It then extends horizontally and engages and passes over the left front pulley 73b and travels downwardly and engages and passes below pulley 93b. Cable 141 then travels along axis A2, engages with pulley 103b and travels along axis A4, extends between pulleys 215b, 216b and terminates at the stopper 133b. Pulleys 240 and 93b can travel vertically (up and down) with the carriage and arm assembly 80 without changing the tension of cable 141. During adjustments cable 141 engages and travels along pulley 241, 72a, 173, 72b, 73b, while anchors 133a and 133b remain at their original positions.

[0067] Referring to FIG. 1, 2, 3a, 4. In order to provide for safe and effortless vertical adjustment of the carriage and arm assembly 80, counterbalance assembly 150 is provided. The counterbalance assembly 150 comprising a counterweight 151, rollers 152a, 152b, 152c, 152d upper reinforcement 117, lower reinforcement 118, a pair of guide rails 115, 116, and transfer pulleys 153, 154. The guide rails 115, 116 connect at the top of upper reinforcement 117 and at the bottom of lower reinforcement 118. The counterweight 151 and rollers 152a, 152b, 152c, 152d are operatively connected and sized to provide rolling operation with guide rails 115, 116. Cable 142 is attached to cable anchor 155 of pulley mount 88. Cable 142 extends upwardly, engages, and passes over transfer pulley 154 which is mounted to the underside of cover plate 42 which is attached to upper frame reinforcement 60. Cable 142 then travels horizontally, engages, and passes over transfer pulley 153 mounted to upper reinforcement 117 and extends downwardly and terminates at cable anchor 119 attached to counterweight 151.

[0068] Carriage and arm assembly 80 is interconnect via cable 142 and transfer pulleys 153, 154 with counterweight 151, and during vertical adjustments of the carriage and arm assembly 80 they travel the same distance but in opposite directions. The weight of the carriage and arm assembly 80 is approximately equal to the weight of the counterweight 151. Those skilled in this art will readily appreciate the described above counter balance assembly 150 is used to explain the operation of present invention as there are other methods which could be used without departing from the spirit of the invention. For example; devices that combine pulleys with gas springs. Referring to FIG. 10a, 10b alternative counter-balance assembly 220 can be used instead of counter balance 150. Alternative counter balance assembly 220 comprising base plate, 221, stationary arm 222, movable arm 223, gas spring cylinder 229, two sets of three pulleys 226a,b,c and 227a,b,c, triple pulley mount 230 and cable mount bracket 225. Bottom end of the stationary arm 222 is attached to the base plate 221 with the top end pivotally connected with first end of the movable arm 223. Second end of the movable arm 223 is shaped and sized to accommodate three pulleys 226a, b,c. Gas spring cylinder 229 is pivotally attached through the fork bracket 228 to the mid section of the movable arm 223 at the top end and to base plate 221 via base bracket 224. Triple pulley mount 230 with pulleys 227a,b,c is mounted to base plate 221 at the far end from stationary arm 222. Cable 142 is attached to base plate 221 via base bracket 224 passing over and engaging pulleys 226c, 227c, 226b, 227b, 226a, 227a, respectively, and exits and passes over transfer pulleys 153, 154 and terminates at the cable anchor 155 of pulley mount 88. Pulley mount 88 illustrates positions of carriage and arm assembly 80 and is interconnected via cable 142, transfer pulleys 153, 154 pulleys 227a,b,c and 226a,b,c via movable arm 223 with gas spring cylinder 229. Because of the pulley ratio of five to one (5:1), for every inch of travel of gas spring cylinder 229, carriage and arm assembly 80 illustrated by pulley mount 88 will travel respectively five inches. Also, resistance created by the gas spring cylinder 229, pulleys 226a,b,c, 227a,b,c and movable arm 223 equalizes resistance of the moving carriage and arm assembly 80. Other devices may also include winch type mechanisms (mechanical, electrical with cord or rechargeable batteries as a source of power), mechanical springs and pulleys, and commercially available spring balancers, elastic bands and elastic bands with pulleys, electric servo motors and remotely controlled electric motors with brakes.

[0069] The present invention can be adjusted to many different positions to perform a variety of exercises. Referring now to FIG. 1, 2, 8, 9. To select desired width for exercise, arms 100a, 100b can be rotated about axes A1 and A2 and locked in a pre-selected position. In order to rotate the arms 100a and 100b to different positions, the exerciser removes pins 108a, 108b from apertures 85 in selector plate 89. With pin 108a withdrawn from apertures 85 in selector plate 89, arm 100a is free to rotate about axis A1 over an arc of approximately 180 degrees and can be locked in one of the series of pre-selected positions based on increments defined by the apertures 85. In the present invention increments of 22.5 degrees are used but any other practical spacing can be used. Arm 100b can be adjusted the same way like arm 100a described above. Each of the arms 100a and 100b can be rotated about axis A1 and A2 and locked in a selected position irrespectively from each other and regardless of their width

and position of the carriage and arm assembly 80 on the vertical post 40 without changing the tension in cable 141.

[0070] After pre-selecting the width of the arms 100a, 100b the exerciser can adjust the carriage and arm assembly 80 to a proper height for the exercise. To change the vertical (height) position of the carriage and arm assembly 80, exerciser has to remove carriage selector pin 95 from the apertures 41 in vertical post 40 which can be accomplished by manipulating handle 96 connected via linkage 97 with carriage selector pin 95. With carriage selector pin 95 disengaged from apertures 41, carriage and arm assembly 80 is free to move up or down along vertical post 40 engaging rollers 82a, 82b, 82c.

[0071] Described above 3 point arm adjustment method is very effective in creating new positions for exercise. As it can be seen, different height positions of the carriage and arm assembly 80 combined with different configurations of the adjustable arms 100a, 100b provide multiple widths for low and high pulley exercises as well as multiple heights for narrow and wide grip exercises. As it should be noted, prior art machines would require adjustments at four locations (points) to achieve a similar number of positions available for exercise.

[0072] One point height adjustment for carriage and arm assembly 80 with unchanged configuration of arms 100a, 100b greatly shortens transition time between exercises and can simplify more complex workout routines, such as circuit training. With one point height adjustment, exerciser can switch in seconds from low to mid or even high pulley exercises which with prior art, equipment would require at least two separate adjustments. As it can be seen in FIG. 8, 9, all starting positions for exercise lie in one plane P (Indicated by straight vertical line in FIG. 9). This arrangement makes all the adjustments for new positions for exercise easily predictable by the exerciser and it greatly simplifies the use of the bench which doesn't need to be moved to fit new arm positions. Ends of arms 100a, 100b can easily reach settings for high pulley exercises with three adjustment points (at pins 108a, 109b and handle 96) placed at one convenient location. High pulley level can be adjusted by each exerciser to meet their individual needs. With the presented adjustment method for creating new positions for exercise, handles 131a, 131b at the ends of arms 100a, 100b can be brought within a view inches from the starting position for exercise which allows for greater economical use available for exercise cable length of cable 141 (FIG. 4). This ability can be used and appreciated in the fields of rehabilitation and physiotherapy where precise positioning, proper form and execution of the path of the exercise is very important.

[0073] As it can be seen in FIG. 9, present invention is always ready (by providing sufficient space in front of the machine) for various lifting or pulling exercises that require pure vertical resistance without additional attachments or changing of the body positions of the exerciser (as seen in some of the prior art machines). As seen, the presented machine offers full range of undisturbed (by bench) functional exercises without sacrificing their proper form.

[0074] Present invention also offers wide range of bench exercises. As it can be seen in FIG. 1, 2, in order to perform bench exercises, exerciser has to bring swing away workout station 190 from storage position (FIG. 2) to exercise position (FIG. 1). Those skilled in the art will understand that the described bench is just an example of a workout station which can be used with the present invention and that the subject of the invention is the method of bringing the workout station to

the exercise position (FIG. 1) and removal of the entire station (not partial) to the storage position (FIG. 2).

[0075] Bench assembly **180** is connected to swing able arm **193** and can be easily moved from storage to workout position by exerciser by rotating entire swing away workout station **190** about pivot point **191** and securing its position by inserting retractable locking pin **196** into stationary lock receiver **195** located at the end of central reinforcement **34**. At this position, exerciser can select proper angle for back support **182** by inserting tilt selector pin **184** into one of the apertures in tilt selector plate **183**. Those skilled in the art will recognize that the shape and size of the swing able arm **193** can be determined by the type of workout station used with the present invention. Bench assembly **180** can be also adjusted closer or farther away from vertical post **40** and carriage and arm assembly **80** for providing exerciser with more options and ability to maintain proper form during exercises. Position of sliding sleeve **188** can be selected and secured with retractably mounted slide selector pin **197** inserted in one of the selector holes (not shown) in swing able arm **193**. Even with bench assembly **180** in workout position most of the adjustments for carriage and arm assembly **80** can be accomplished. Exerciser can also pre-select the configuration of carriage and arm assembly **80** before placing the bench assembly **180** into workout position.

[0076] Because of the described previously capability of carriage and arm assembly **80** to adjust for different positions for exercise, exerciser can perform bench exercises using wide to narrow grip options and can simulate incline, decline and flat bench positions by changing the height of carriage and arm assembly **80**. Handle units **130a**, **130b** can align themselves with the angle of cable **141** when pulled or pushed by the exerciser, which gives more exercise options for the exerciser. Because handle units **130a**, **130b** rotate in one plane P (FIG. **8**, **9**), exerciser can easily predict new positions of the arms and don't need to adjust their body positions to the new location of the arms (like it can be seen in some of the prior art machines described before).

[0077] Referring to FIG. **1**, **2**, **3a**. The present invention can also be used for non-weight lifting exercises such as: chin up's, dips, push up's, reverse push up's and abdominals. For these exercises the bench assembly **180** has to be in storage position and bars **201a**, **201b** (**201b** not shown) have to be attached to the arms **100a**, **100b**. Exerciser then sets arms **100a**, **100b** to a desired width and carriage and arm assembly **80** to a suitable height and can perform a chosen exercise using bars **201a**, **201b** (**201b** not shown) detachable handles **204a**, **204b** or other attachments like different lengths of chain with handles, sleeves for hang-down abdominal exercises and detachable bars of different lengths.

[0078] In order to do all mentioned exercises with prior art equipment, extra dip, chin up, push up, reverse push up and abdominal stations are usually added to the side or back of the machine taking more space and making the machine more costly to build. Prior art equipment lacks the adjustability required for different exerciser size and the level of intensity of the exercise cannot be changed. Present invention overcomes shortcomings of the prior art by using adjustability of the carriage and arm assembly **80** without adding extra stations. This design saves space by attaching bars **201a**, **201b** (**201b** not shown) to arms **100a**, **100b** and using the adjustability of the carriage and arm assembly **80** to create different positions for exercises instead of adding extra stations which always add to the cost and space requirement of the machine.

Simple adjustments of the carriage and arm assembly **80** allow the exerciser to set the machine to better fit their size and fitness level. Users can easily adjust the machine to their size and add more variations to their exercises by changing their body position and resistance.

[0079] Body weight exercises are very effective but can be challenging for beginners, that's why the ability to change resistance and positions without adding extra stations and increasing the size of the machine is a very useful and is not addressed this way by prior art. For example; to decrease resistance of the dips, the exercisers can lower the position of the carriage and arm assembly **80** and put their feet flat on the floor and to increase resistance carriage and arm assembly **80** can be positioned higher. To increase the resistance of the push up and reverse push up, bars **201a**, **201b** (**201b** not shown) can be lowered by lowering carriage and arm assembly **80**, to decrease resistance of the push up and reverse push up bars **201a**, **201b** (**201b** not shown) can be raised by adjusting height of carriage and arm assembly **80**.

[0080] Adjustability of present invention can be also used with high speed exercises and stretching. High speed exercises are often used for sport specific applications like boxing, martial arts, golf swing, physiotherapy and rehabilitation, or just for low impact toning and shaping exercises. However, the traditional weight stack cannot be used safely in this application because of the generated momentum. The use of the safer ratio (4:1) reduces this problem, but because of the extra weight, it has only practical use in specialized gym equipment. Elastic tubes can be attached to the ends of the arms and used instead. Weight selected at the weight stack should be set to the maximum. All the positions available with the machine can be used with elastic tubes.

[0081] Thanks to the ability to change the height of both arms **100a**, **100b** at the same time with just one adjustment, present invention can mimic most of the positions provided by professional and specialized cage type stretching machines. The present invention can accommodate users of various sizes with simple adjustments/transformations. Arms **100a**, **100b** provide enough support and strength that any desirable position can be chosen by the exerciser for various stretching exercises.

[0082] Referring to FIG. **8**, **9** an exercise Plane P is illustrated. Based on the configurations of carriage positions combined with the adjustable arms positions, it is evident that high and low pulley exercises as well as wide and narrow grip exercises are possible with the present arrangement without unnecessarily extending the lengths of arms **100a**, **100b**. Therefore, the present invention can be built shorter than typical exercises machines of this nature offering high and low pulley exercises using shorter and stronger arms, thereby offering a more compact, user-friendly, and economical design.

[0083] The present invention can be used for many different types of exercises which normally require a number of different fitness machines or devices. It can be used as a functional trainer machine for unrestricted user defined exercises with multi-directional and adjustable resistance. It provides multiple bench exercises including flat, incline and decline positions with narrow or wide grips ranging from any level between a low to high pulley location. It can also be used for non-weight lifting exercises such as chin-ups, pushups, reverse pushups and abdominals, with taking under consideration the size and the fitness level of the exerciser. When exerciser wants to perform high-speed exercises where tradi-

tional weight stack or free-weights cannot be used safely because of the generated momentum, elastic tubes can be attached at the end of the arms and used instead. The present invention can be used for various stretching exercises. What should be noted is that the present invention supports multiple functions using just one adjustable structure without increasing required floor space, while most prior art machines build additional structures for each application increasing the overall size and cost.

Alternative Embodiments

[0084] Machine can be built with two weight stacks (sources of resistance). It can be done by splitting cable **141** in half, eliminating pulley **173** connecting available ends of the cable with two sources of resistance.

[0085] It can be built with different configuration of pulleys with different load ratios. Pulleys can be positioned at different angles and at different locations as long as the cable compensation is maintained and changes of the angular arm positions **100a**, **100b** and adjustments (up or down) of the carriage and arm assembly **80** don't change the tension in cable **141** (or split cable **141**) when two sources of resistance are used. Connection at the source of resistance always terminates at the same location before and after exercise. Load ratios can be changed by adding or removing pulleys and changing the length of the cable. Science of pulleys has been known for thousands of years and mechanical engineering books provide adequate information on how to build various pulley trains with different load ratios.

[0086] Angle of arms **100a**, **100b** can be changed by either changing the angle between arm and axis **A1**, **A2**, or changing the angle of axis **A1**, **A2** from the horizontal position.

[0087] Handle units **130a**, **130b** can be built with just one pulley.

[0088] Vertical post **40** can also be built in any other practical position other than the vertical position. Also, additional vertical posts, guide posts or any other practical posts may be added for stability, strength and overall reinforcement.

[0089] Additional/different locking mechanisms can be used to secure carriage and arm assembly **80**. These mechanisms can include; cam locks, screw in locking pins, push button with electric brake, compression pads, screw or cam activate and others.

[0090] Numbers of rollers guiding carriage and arm assembly **80** on vertical post **40** can be different than the three used in the present invention. Also an additional guide post can be placed behind vertical post **40** and guide rollers can run on the inside surfaces between the two posts.

[0091] Rollers **82a**, **82b**, **82c** and vertical post **40** can be of different shape and different profile for better and more stable rolling action. Also different devices can be used for guiding like; sleeve bearings, guide bushings, linear bearings and others.

[0092] Counterbalance assembly **150** can be operated with remote control electric motor.

[0093] Arms **100a**, **100b** can have additional anchoring points for attaching resistance bands. They can be located at bearing sleeve **211a**, **211b** and at any suitable location on the carriage and arm assembly **80**.

[0094] Other multifunctional benches and exercise stations may be adopted and designed to work with the present invention.

[0095] Machine can be designed and built without a multifunctional bench and dip bars.

[0096] Different materials, sizes and interconnections can be used for all components.

[0097] Machine can be built so that the axis of rotation **A1**, **A2** are not parallel to each other.

[0098] Machine can be built in a 'light duty version' for lighter loads. Different lighter materials like aluminum or plastics can be used to build carriage and arm assembly **80**. Machine like this can work without counter balance assembly **150**.

I claim:

1. A three-point adjustment multipurpose exercise machine, comprising:

- a. a frame including a first substantially upright post;
- b. said first substantially upright post describing a substantially vertical axis and a horizontal axis;
- c. a slidable carriage assembly having means to slide and lock on the first substantially upright post along said substantially vertical axis, whereby said slidable carriage assembly describes a first point of adjustment for said machine for adjustment of a vertical height of the slidable carriage assembly along the first substantially upright post;
- d. a right arm assembly and a left arm assembly, each rotatably, adjustably, and independently mounted to said slidable carriage assembly and each said arm assembly having an axis of rotation parallel to the horizontal axis, whereby said mounting point of the right arm assembly describes a second point of adjustment for said machine for adjusting the right arm assembly and said mounting point of the left arm assembly describes a third point of adjustment for said machine for adjusting the left arm assembly, the left arm assembly having a left handle unit and the right arm assembly having a right handle unit;
- e. a resistance assembly;
- f. at least one cable coupling the left handle unit and the right handle unit and the resistance assembly, wherein there is a tension in the at least one cable; and
- g. means for keeping the tension in the at least one cable substantially the same, for maintaining the left handle unit at a first distance from the slidable carriage assembly, and for maintaining the right handle unit at a second distance from the slidable carriage assembly when and as the vertical height of the slidable carriage assembly along the first substantially upright post is changed, when and as the left arm assembly is rotated with respect to the first substantially upright post in a manner that causes at least a portion of the at least one cable to move, and when and as the right arm assembly is rotated with respect to the first substantially upright post in a manner that causes at least a portion of the at least one cable to move; and

whereby a height and the horizontal span each of the left arm assembly and the right arm assembly can be adjusted by said three points of adjustments, through sliding the carriage assembly along the first substantially upright post and by pivotably engaging each of the left arm assembly and the right arm assembly with the slidable carriage assembly.

2. The three-point adjustment multipurpose exercise machine of claim 1, wherein said means to slide the slidable carriage assembly is comprised of rollers, and bolts.
3. The three-point adjustment multipurpose exercise machine of claim 1, wherein

said means to lock the slidable carriage assembly on the first substantially upright post is comprised of a spring loaded pin.

4. The three-point adjustment multipurpose exercise machine of claim 1, wherein said each handle unit comprising:

- a. a handle having first and second ends;
- b. a flexible strap attached to each said end of the handle and formed into a loop; and
- c. a stopper fitted over the strap,

whereby each handle can be grasped by an exerciser, and when pulled will cause rotation of a pulley assembly about the arm axis and allow the direction of the at least one cable to align with the direction of the pulling force exerted by the exerciser via the each handle unit.

5. The three-point adjustment multipurpose exercise machine of claim 1,

having a counter balance assembly for counter balancing the weight of said slidable carriage assembly and arm assembly during adjustment of the vertical height of the slidable carriage assembly along the first substantially upright post.

6. The three-point adjustment multipurpose exercise machine of claim 5, wherein said counter balance assembly is comprised of a gas spring and a set of pulleys.

7. The three-point adjustment multipurpose exercise machine of claim 1, comprising

a source of resistance said at least one cable connecting the source of resistance to at least one arm assembly.

8. The three-point adjustment multipurpose exercise machine of claim 1, wherein

a single cable couples both of the handle units with the resistance assembly.

9. The three-point adjustment multipurpose exercise machine of claim 1, and wherein

the slidable carriage assembly, the left arm assembly, the right arm assembly, and the first substantially upright post are configured so that when and as the vertical height of the slidable carriage assembly along the first substantially upright post is adjusted, when and as the left arm assembly is rotated with respect to the first substantially upright post in a manner that causes at least a portion of the at least one cable to move, and when and as the right arm assembly is rotated with respect to the first substantially upright post in a manner that causes at least a portion of the at least one cable to move, the left handle unit and the right handle unit remain in a plane which is substantially parallel to and a distance away from the first substantially upright post and the tension in the at least one cable remains substantially the same.

10. A three-point adjustment multipurpose exercise machine of claim 1, further comprising

a cable compensator assembly means to maintain the tension in said cable and a constant length of cable for the exercise,

whereby, when said carriage and arm assembly are moved upward or downward from any location on the vertical post, said cable compensator assembly travels in the opposite direction and one half of the distance traveled by the carriage and arm assembly, and a cable anchor holds cable compensator assembly in fixed position at any pre-selected height of the carriage and arm assembly and enables cable to transfer resistance from said resis-

tance assembly to the handle units used by exerciser, and whereby said cable compensator assembly compensates both halves of cable at the same time without changing the tension or length of the cable available for exercise.

11. A three-point adjustment multipurpose exercise machine, comprising:

- a frame having at least one substantially upright post;
- said post describing a substantially vertical axis and a horizontal axis;

a slidable carriage assembly having means to slide and lock on the upright post along said substantially vertical axis, whereby said carriage describes a first point of adjustment for said machine for height adjustment;

- a right and a left arm assemblies rotatably, adjustably, and independently mounted to said slidable carriage and each said arm assembly having an axis of rotation parallel to the forward horizontal axis, whereby said mounting point of the right arm describes a second point of adjustment for said machine for adjusting the right arm and said mounting point of the left arm describes a third point of adjustment for said machine for adjusting the left arm, each arm assembly having a handle unit;

a resistance assembly; and

at least one cable coupling the handle units, arm assemblies and the resistance assembly,

further comprising a swing away work out station which includes a bench assembly, and a swing able arm;

wherein the bench assembly is connected to a first end of the swingable arm, and wherein a second end of the swingable arm, opposite the first end of the swingable arm, is rotatably mounted to the frame; and

whereby said bench assembly can be stored on at least one side of the machine in a storage position from the exercise position and the freed space in front of the machine can be utilized for undisturbed functional exercises.

12. A method of three point adjustment for creating new positions for functional exercises using an exercise machine having a slidable carriage on a substantially vertical post, a left arm and a right arm assemblies, said arms rotatably, adjustably, and lockably mounted on the carriage, the method comprising the steps of:

- a. standing in front of the machine, facing the machine;
- b. grasping said left arm with one hand at its mid-section;
- c. unlocking the left arm with the other hand and holding unlocked moving the left arm by rotating about horizontal axis until desired width is achieved;
- d. locking the left arm in a chosen location;
- e. grasping said right arm with one hand at its mid-section;
- f. unlocking the right arm with the other hand and holding unlocked moving the right arm by rotating about horizontal axis until desired width is achieved;
- g. locking the right arm in a chosen location;
- h. grasping said carriage with one hand;
- i. unlocking and adjusting said carriage to a desired height by sliding on said vertical post; and
- j. locking said carriage in the desired location.

13. The three-point adjustment multipurpose exercise machine of claim 1, wherein

the at least one cable has a first portion and a second portion;

wherein the axis of rotation of the right arm assembly coincides with the first portion of the at least one cable; and

and the axis of rotation of the left arm assembly coincides with the second portion of the at least one cable.