



US011904050B1

(12) **United States Patent**
Nordahl

(10) **Patent No.:** **US 11,904,050 B1**
(45) **Date of Patent:** ***Feb. 20, 2024**

(54) **METHOD OF MAKING A PACKAGED CANNABIS JUICE PURÉE FORMED THROUGH HIGH PRESSURE PROCESSING**

9,220,294	B2	12/2015	McCullough	
9,277,763	B2	3/2016	Beckman et al.	
9,955,716	B1 *	5/2018	Nordahl	A61K 36/185
9,956,173	B1 *	5/2018	Nordahl	A61K 36/185
9,956,174	B1 *	5/2018	Nordahl	A61K 36/185
2007/0275131	A1	11/2007	Bertini et al.	426/115

(71) Applicant: **Jeff Nordahl**, Soquel, CA (US)

(72) Inventor: **Jeff Nordahl**, Soquel, CA (US)

(*) Notice: Subject to any disclaimer, the term of this patent is extended or adjusted under 35 U.S.C. 154(b) by 0 days.

This patent is subject to a terminal disclaimer.

(21) Appl. No.: **15/965,982**

(22) Filed: **Apr. 30, 2018**

Related U.S. Application Data

(63) Continuation of application No. 15/213,334, filed on Jul. 18, 2016, now Pat. No. 9,956,173.

(60) Provisional application No. 62/292,732, filed on Feb. 8, 2016.

(51) **Int. Cl.**

A61K 9/00	(2006.01)
B65D 85/72	(2006.01)
B65D 81/20	(2006.01)
A61K 31/352	(2006.01)
A61K 31/192	(2006.01)
A61K 36/185	(2006.01)

(52) **U.S. Cl.**

CPC **A61K 9/0095** (2013.01); **A61K 31/192** (2013.01); **A61K 31/352** (2013.01); **A61K 36/185** (2013.01); **B65D 81/2023** (2013.01); **B65D 85/72** (2013.01); **A61K 2236/15** (2013.01); **A61K 2236/31** (2013.01)

(58) **Field of Classification Search**

CPC .. **A61K 9/0095**; **A61K 31/192**; **A61K 31/352**; **A61K 36/185**; **A61K 2236/15**; **A61K 2236/31**; **B65D 81/2023**; **B65D 85/72**
USPC 426/86, 106, 112, 115, 392, 618
See application file for complete search history.

(56) **References Cited**

U.S. PATENT DOCUMENTS

1,933,596	A	11/1933	Maclea	206/804
2,157,476	A	5/1939	Brodesser	206/525
2,248,963	A	7/1941	Copeman	206/457
3,417,862	A	12/1968	Fong	206/517
4,452,823	A	6/1984	Connolly et al.	426/115
5,232,726	A	8/1993	Clark et al.	426/519
6,231,904	B1	5/2001	Mueller	426/112
7,906,160	B2	3/2011	Sherwood	426/74
9,044,390	B1	6/2015	Speier	
9,050,631	B2	6/2015	Raichart	
9,066,910	B2	6/2015	Rosenblatt et al.	
9,078,838	B2	7/2015	Andre et al.	
9,095,544	B2	8/2015	Karle et al.	
9,095,563	B2	8/2015	Sekura et al.	
9,149,499	B1	10/2015	Robinson	
9,155,767	B2	10/2015	Hospodor et al.	
9,186,386	B2	11/2015	Speier	
9,205,063	B2	12/2015	Guy et al.	

OTHER PUBLICATIONS

Elamin et al., High Pressure Processing Technology and Equipment Evolution: A Review, *Journal of Engineering Science and Technology Review* 8 (5) (2015) 75-83.*

D.G. Yordanov & G.V. Angelova (2010) High Pressure Processing for Foods Preserving, *Biotechnology & Biotechnological Equipment*, 24:3, 1940-1945.*

Balasuubramaniam et al., Principles and Application of High Pressure-Based Technologies in the Food Industry, *Annu. Rev. Food Sci. Technol.* 2015. 6:435-62.*

"Dr. Courtney's raw cannabis juice", located at: <https://www.alchimiaweb.com/blogen/dr-courtneys-raw-cannabis-juice/>, downloaded on Jul. 13, 2016 (15 pages).

"Ohana Farms CBD Cubes", located at: <http://www.ohanaedu.org/index.php/products/cbd-cubes/>, downloaded on Jul. 18, 2016 (1 page).

"Cannabis Juice: The Elixir of Health", located at: <http://www.cannabis.info/gb/abc/10003309-cannabis-juice-the-elixir-of-health>, downloaded on Oct. 26, 2016 (5 pages).

"Juicing Raw Cannabis", by Martin A. Lee, O'Shaughnessy's, Winter/Spring 2013 (1 page).

"Juicing Cannabis: The Potential Health Benefits of Treating Cannabis Like a Vegetable", by Zack Reichard, Jan. 19, 2013 (4 pages).

"Cannabis: Drink Your Medicine! A Poor Man's Guide to Juicing", by Sharon Letts, Apr. 19, 2013 (24 pages).

"Cannabinoid Blend Calculator", located at: <https://lift.co/cannabinoid-calculator/>, downloaded on Dec. 16, 2016 (1 page)

(Continued)

Primary Examiner — Leslie A Wong

(74) *Attorney, Agent, or Firm* — Adibi IP Group, PC; Amir V. Adibi; Andrew C. Palmer

(57) **ABSTRACT**

A Cannabis juice purée is packaged using high pressure processing (HPP). First, a Cannabis juice purée is formed by collecting raw Cannabis material and blending the raw Cannabis material together with a thickening agent and a sweetening agent. Next, the Cannabis juice purée is deposited into a container and the container is processed using HPP. In HPP, the Cannabis juice purée is loaded into a high-pressure chamber filled with pressure transmitting fluid, such as water. The pressure is applied to the Cannabis juice purée. A lid is used to seal the opening of the container. HPP allows the mixture to be pasteurized without applying heat. HPP extends the shelf life of the Cannabis juice purée to several weeks to months without applying heat that could undesirably decarboxylating the cannabinoids present in the Cannabis juice purée. Shelf life is preserved while providing a liquid beverage form of Cannabis juice purée.

(56)

References Cited

OTHER PUBLICATIONS

"Should You Be Adding Raw Cannabis to Your Smoothie? Some Medical Doctors Say, 'Yes'", located at www.GarmaOnHealth.com, Jun. 14, 2014.

"How Exactly Does Cannabis Juice Work?", Seshata, Oct. 2014.

* cited by examiner

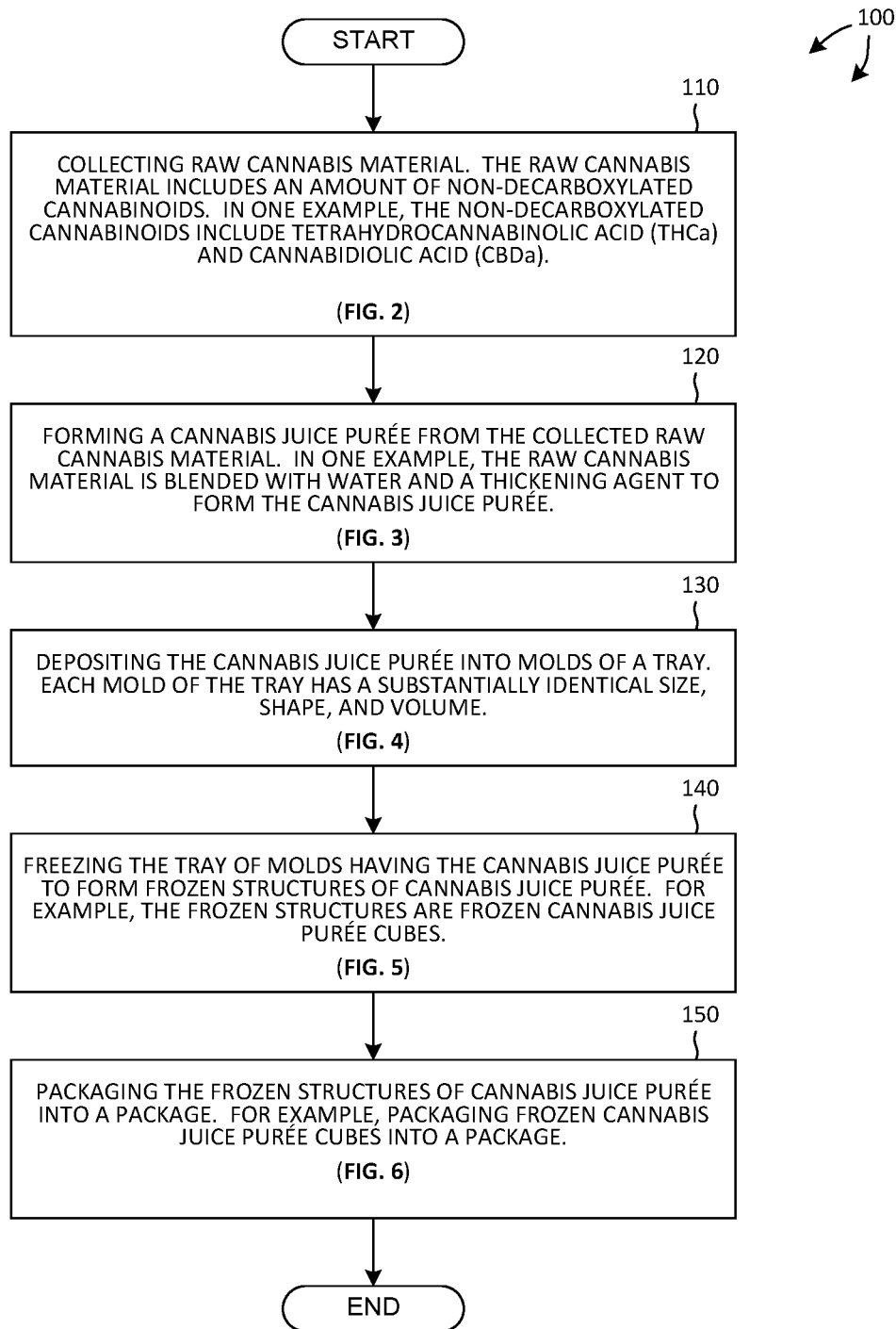

MANUFACTURING AND PACKAGING FROZEN STRUCTURES OF CANNABIS JUICE PURÉE

(FIRST EMBODIMENT)

FIG. 1

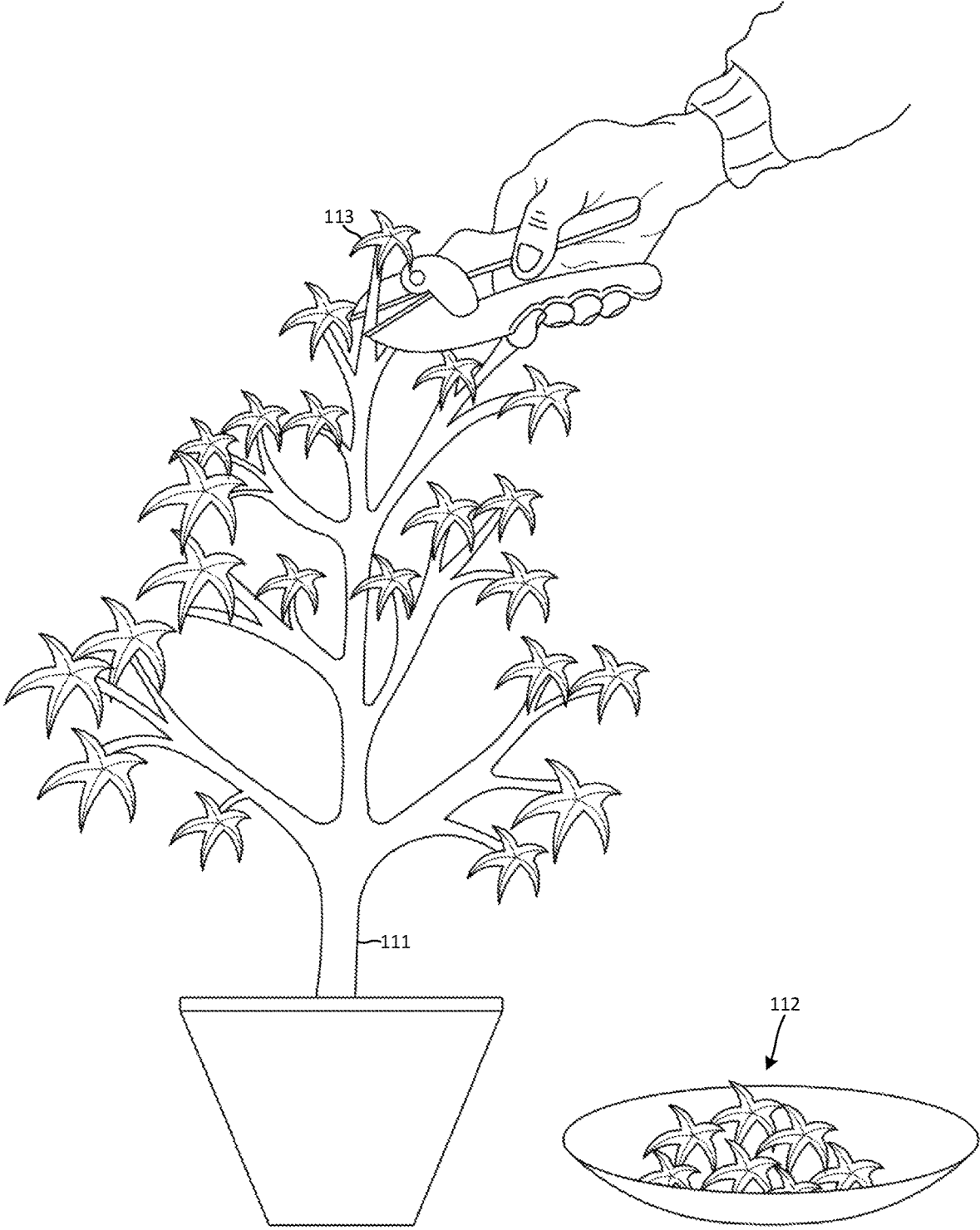

COLLECTING RAW CANNABIS MATERIAL
FIG. 2

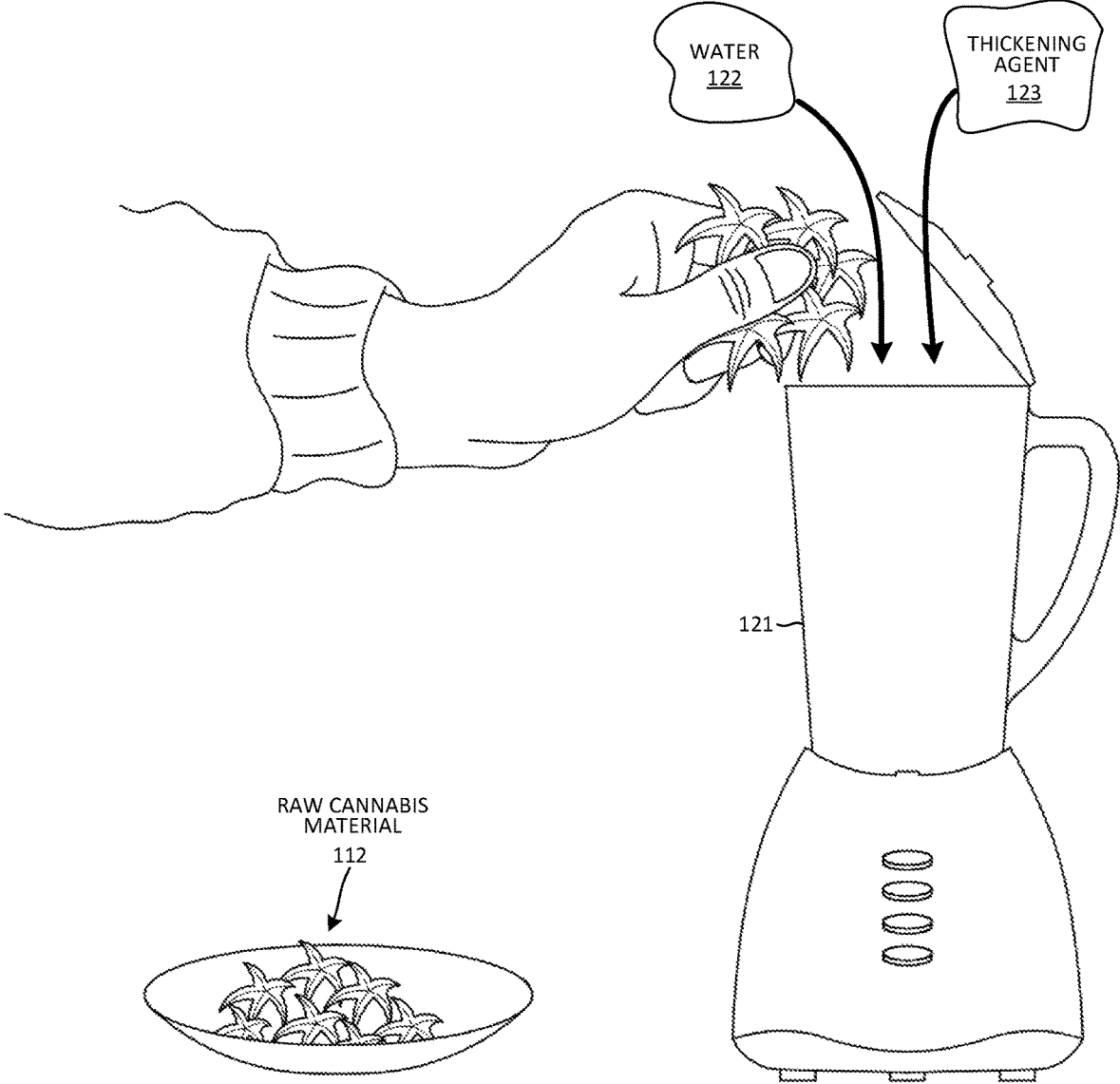

FORMING A CANNABIS JUICE PURÉE

FIG. 3

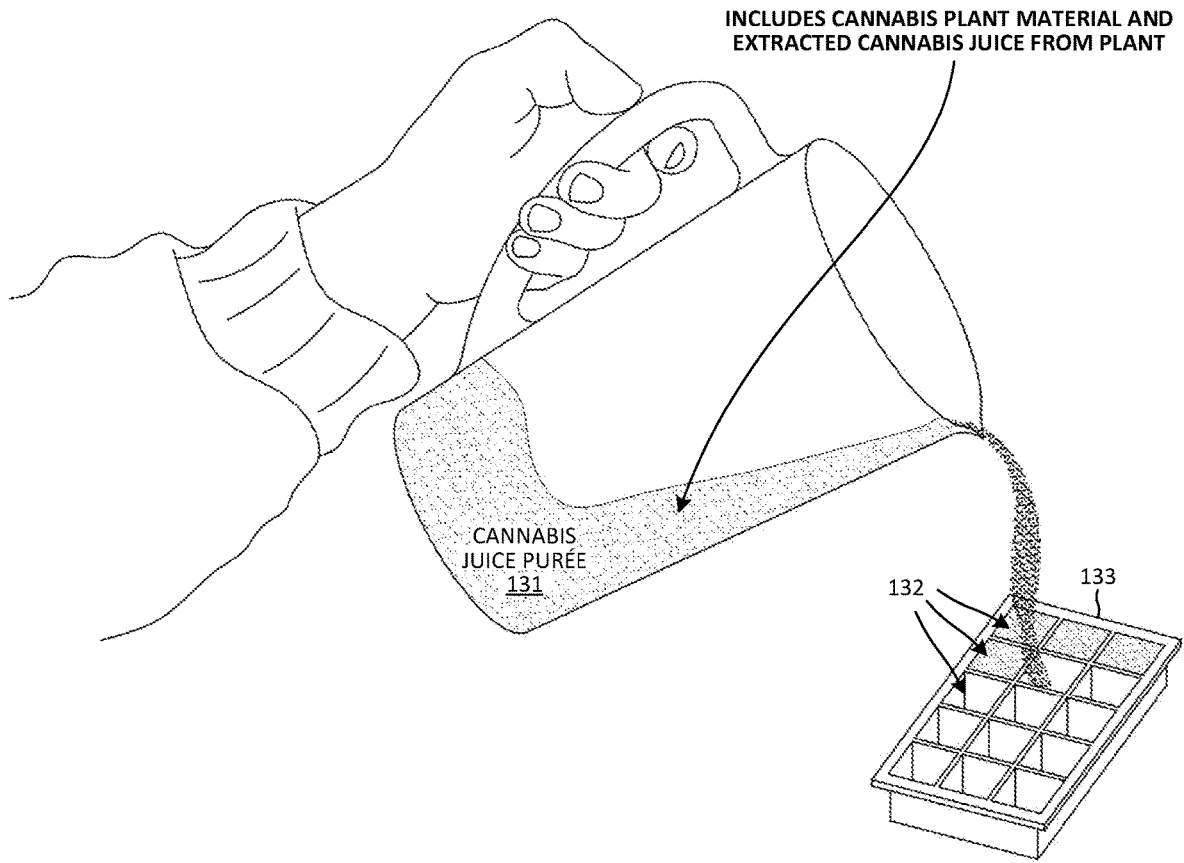

DEPOSITING THE CANNABIS JUICE PURÉE
INTO MOLDS OF A TRAY

FIG. 4

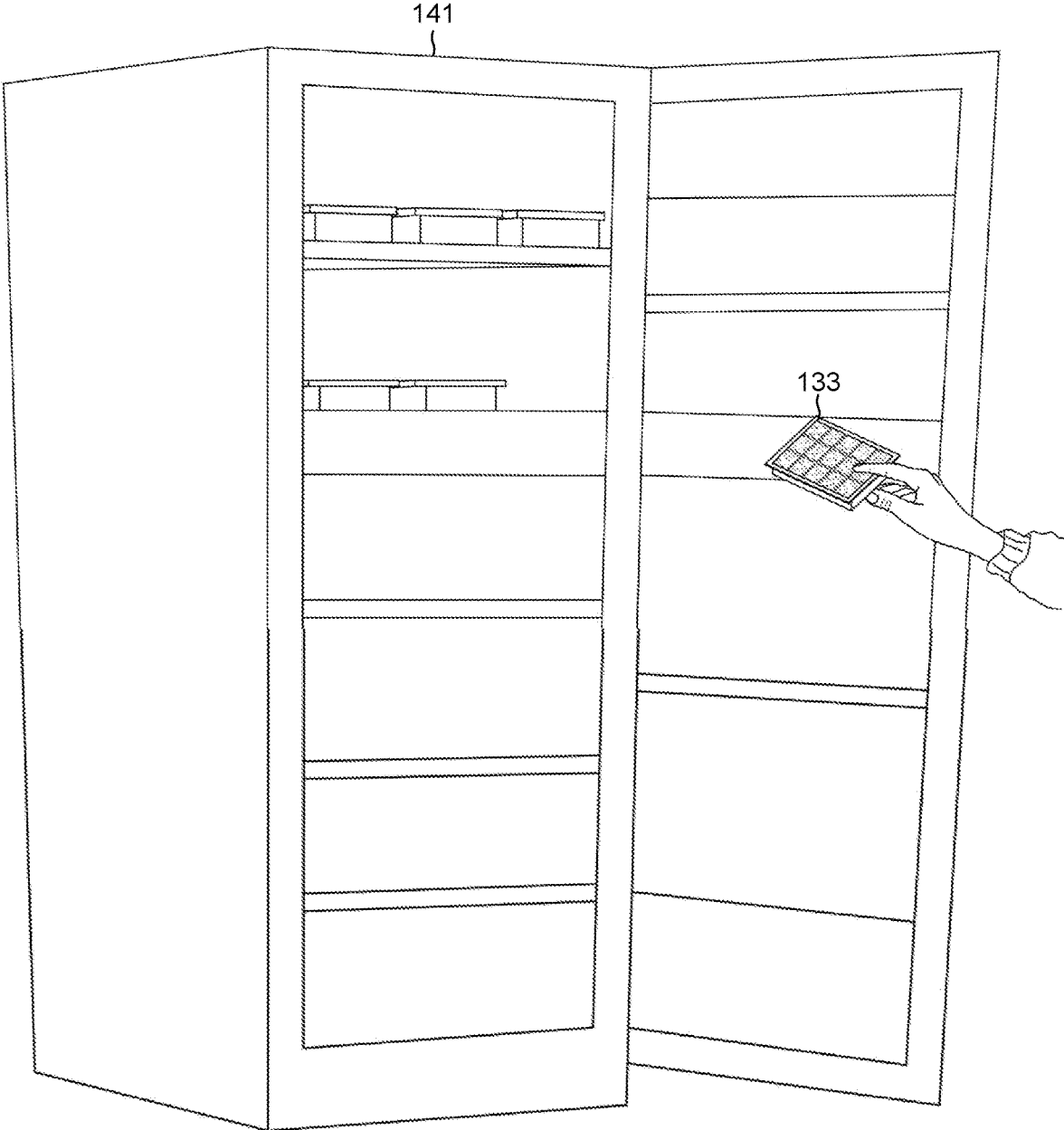

FREEZING THE TRAY OF MOLDS HAVING THE
CANNABIS JUICE PURÉE
FIG. 5

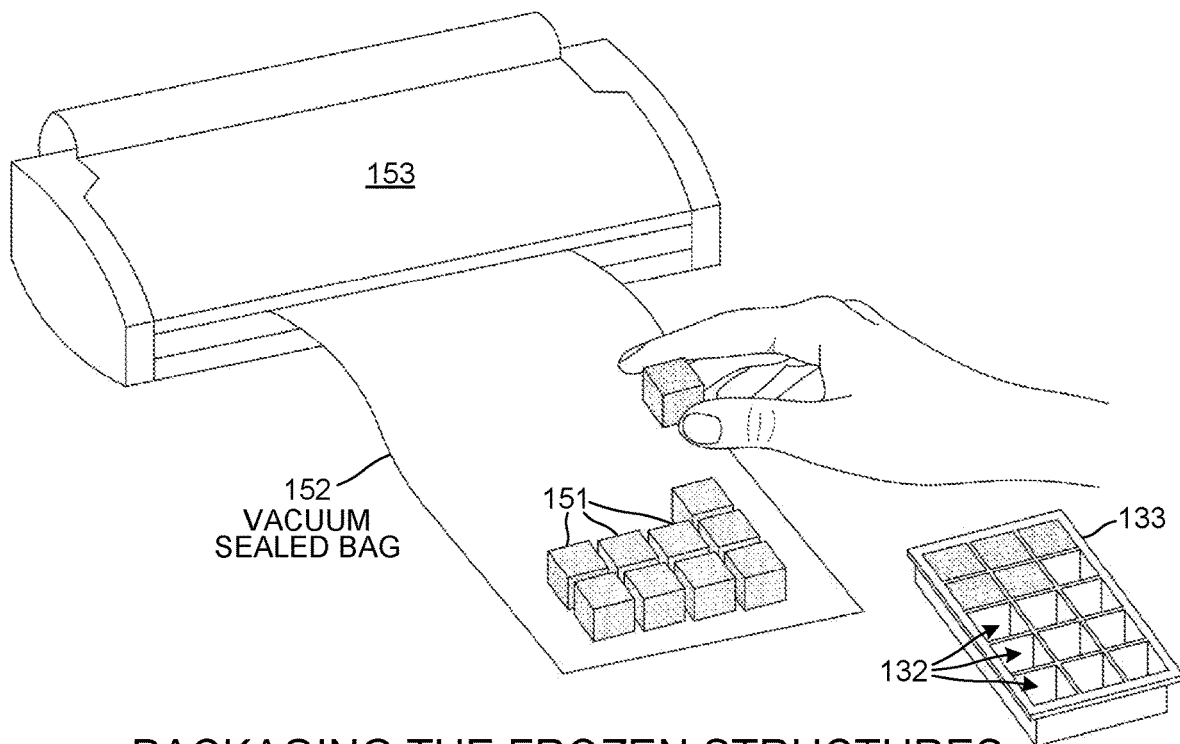

PACKAGING THE FROZEN STRUCTURES INTO A PACKAGE

FIG. 6

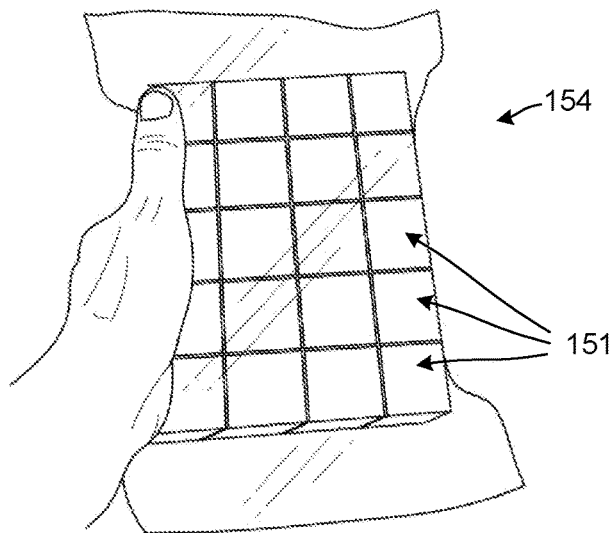

PACKAGE WITH FROZEN STRUCTURES OF CANNABIS JUICE PURÉE HAVING NON-DECARBOXYLATED CANNABINOIDS

FIG. 7

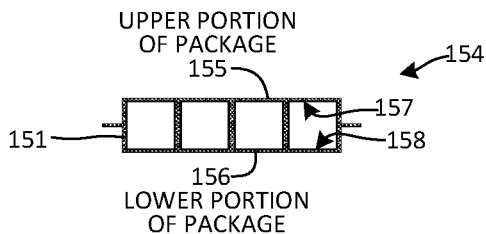

PACKAGE WITH FROZEN STRUCTURES OF
CANNABIS JUICE PURÉE HAVING NON-
DECARBOXYLATED CANNABINOIDS

(SIDE VIEW)

FIG. 8

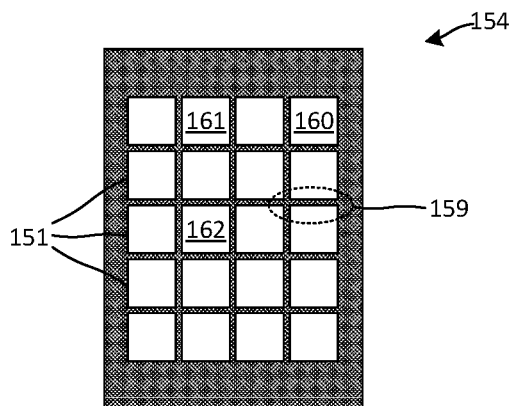

PACKAGE WITH FROZEN STRUCTURES OF
CANNABIS JUICE PURÉE HAVING NON-
DECARBOXYLATED CANNABINOIDS

(TOP VIEW)

FIG. 9

PRE-DETERMINED AMOUNT OF CANNABINOIDS PER FROZEN STRUCTURE

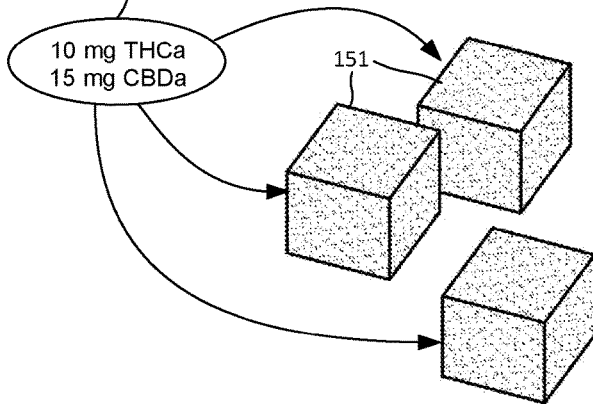

CANNABIS PLANT MATERIAL IN EACH CUBE INCLUDES NON-CANNABINOID COMPONENTS, SUCH AS:

- TERPENES
- FATTY ACIDS
- AMINOACIDS
- ENZYMES
- VITAMINS
- MINERALS
- CAROTENOIDS
- CHLOROPHYLL
- FLAVONOIDS
- DIETARY FIBERS

FROZEN STRUCTURES OF CANNABIS JUICE PURÉE HAVING NON-DECARBOXYLATED CANNABINOIDS
FIG. 10A

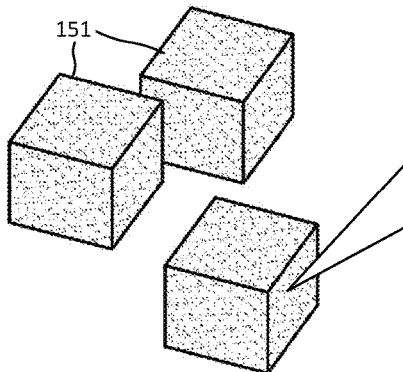

PRE-DETERMINED AMOUNT OF CANNABINOIDS IN EACH STRUCTURE

FROM RAW CANNABIS PLANT:		FROM NON-DECARBOXYLATED HIGH CONCENTRATE CANNABIS EXTRACT (KIEF):	
CBDa	15 mg/cube	CBDa	300 mg/cube
THCa	10 mg/cube	THCa	200 mg/cube
TOTAL FROM RAW CANNABIS:	25 mg/cube	TOTAL FROM NON-DECARB. KIEF:	500 mg/cube

ADDED HIGH CONCENTRATE CANNABIS EXTRACT SUBSTANTIALLY INCREASES (BY AT LEAST 10X) THE AMOUNT OF NON-DECARBOXYLATED CANNABINOIDS IN EACH CUBE

FROZEN STRUCTURES OF CANNABIS JUICE PURÉE HAVING NON-DECARBOXYLATED CANNABINOIDS WITH ADDED NON-DECARBOXYLATED HIGH CONCENTRATE CANNABIS EXTRACT

(ALTERNATE EMBODIMENT)

FIG. 10B

HIGH CONCENTRATE CANNABIS EXTRACT IS OBTAINED BY EXTRACTING THE CONCENTRATED CANNABINOIDS IN THE TRICHOMES THAT FORM ON THE CANNABIS FLOWER

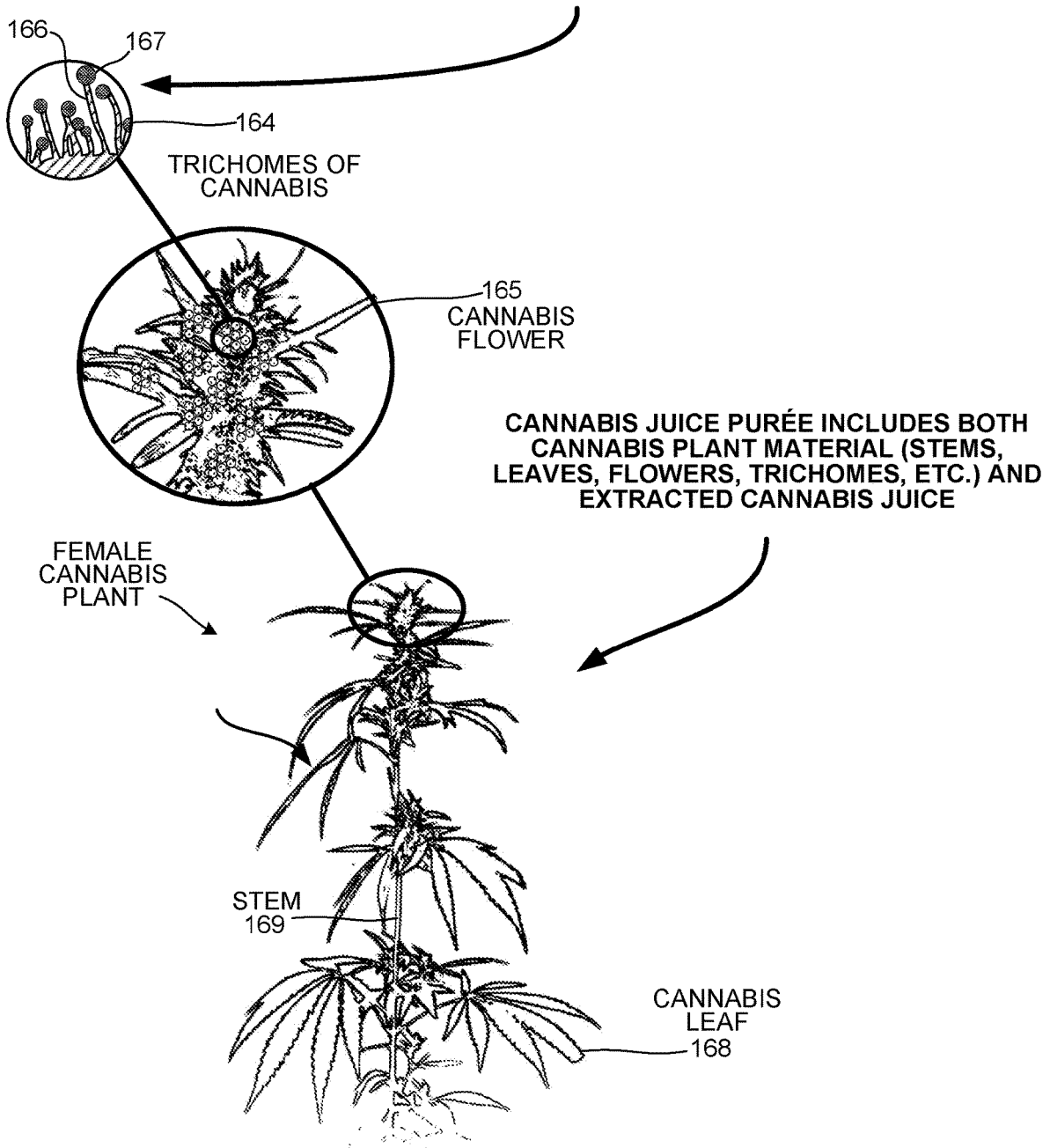

FIG. 10C

170

PRODUCTS OBTAINED FROM CANNABIS PLANT	
NON-CANNABINOID COMPONENTS	CANNABINOID COMPONENTS
<ul style="list-style-type: none"> - TERPENES - FATTY ACIDS - AMINOACIDS - ENZYMES - VITAMINS - MINERALS - CAROTENOIDS - CHLOROPHYLL - FLAVONOIDS - DIETARY FIBERS 	<ul style="list-style-type: none"> - CANNABIGEROLIC ACID (CBGA) - CANNABIGEROVARIN ACID (CBGVA) - TETRAHYDROCANNABINOLIC ACID (THCA) - TETRAHYDROCANNABIVARIN CARBOXYLIC ACID (THCVA) - CANNADIDIOLIC ACID (CBDA) - CANNABIDIVARIN ACID (CBDVA) - CANNABICHROME CARBOXYLIC ACID (CBCA) - CANNABICHROME VARINIC ACID (CBCVA) - TETRAHYDROCANNABINOL (THC) - TETRAHYDROCANNABIDIVARIN (THCV) - TETRAHYDROCANNABIVARIN ACID (THVA) - CANNABIDIOL (CBD) - CANNABIDIVARIN (CBDV) - CANNABICHROMENE (CBC) - CANNABICHROMEVARIN (CBCV) - CANNABIGEROL (CBG) - CANNABIGEROVARIN (CBGV) - CANNABINEROLIC ACID (CBNA) - CANNABIGEROVARINIC ACID (CBNVA) - CANNABINOL (CBN) - CANNABICYCLOL (CBL) - CANNABICYCLOL ACID (CBLA)

NON-CANNABINOID AND CANNABINOID COMPONENTS MAY BE ADDED TO OR EXCLUDED FROM CANNABIS JUICE PURÉE

PRODUCTS OBTAINED FROM CANNABIS PLANT

FIG. 10D

163

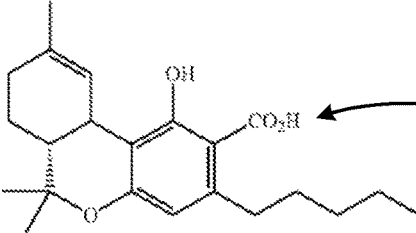
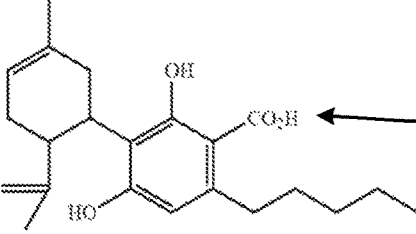
TYPE	STRUCTURAL FORMULA
<p>TETRAHYDROCANNABINOLIC ACID (THCa)</p>	
<p>CANNABIDIOLIC ACID (CBDa)</p>	

NON-DECARBOXYLATED
TYPES HAVE CARBOXYL
GROUP

EXAMPLES OF NON-DECARBOXYLATED
CANNABINOIDS
FIG. 11

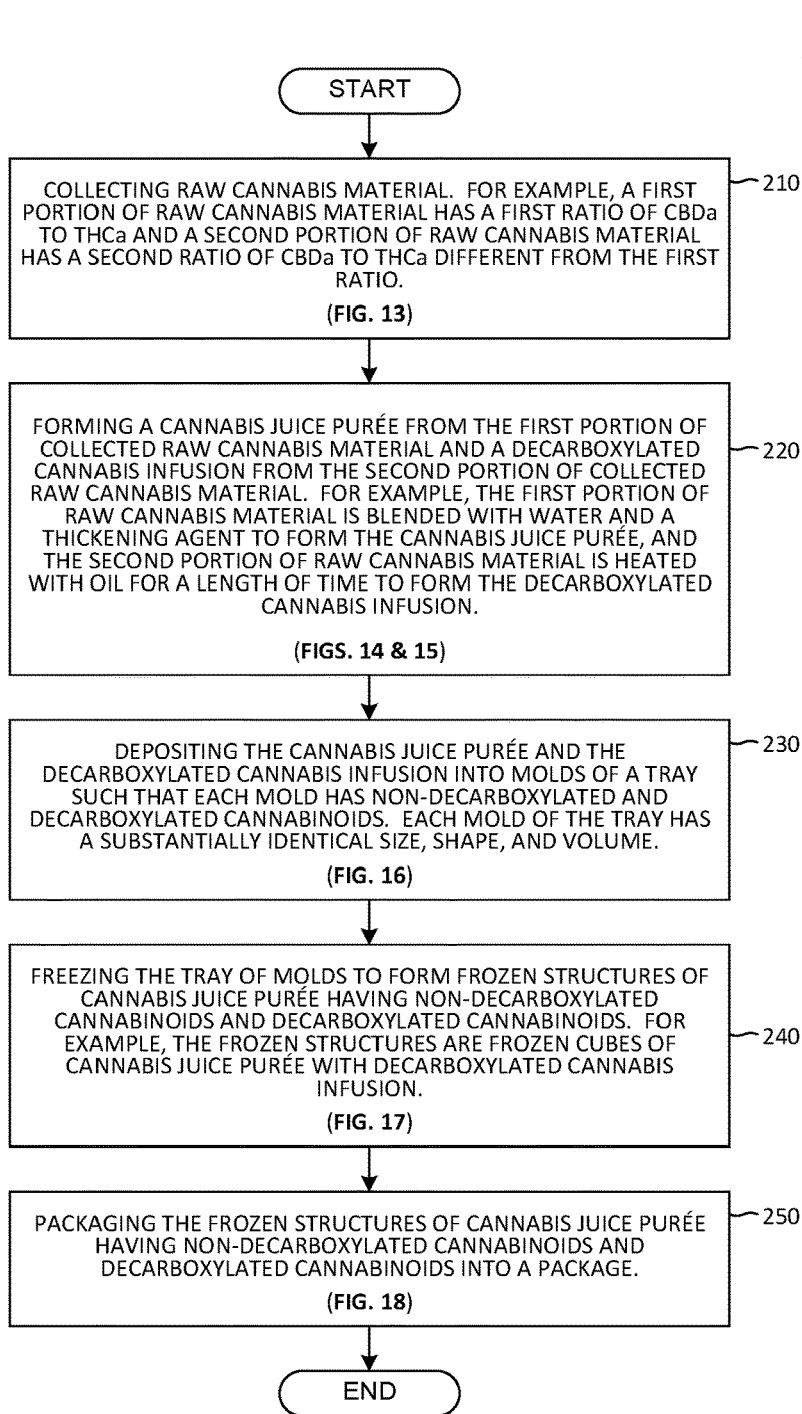

MANUFACTURING AND PACKAGING FROZEN STRUCTURES OF CANNABIS JUICE PURÉE WITH NON-DECARBOXYLATED AND DECARBOXYLATED CANNABINOIDS

(SECOND EMBODIMENT)

FIG. 12

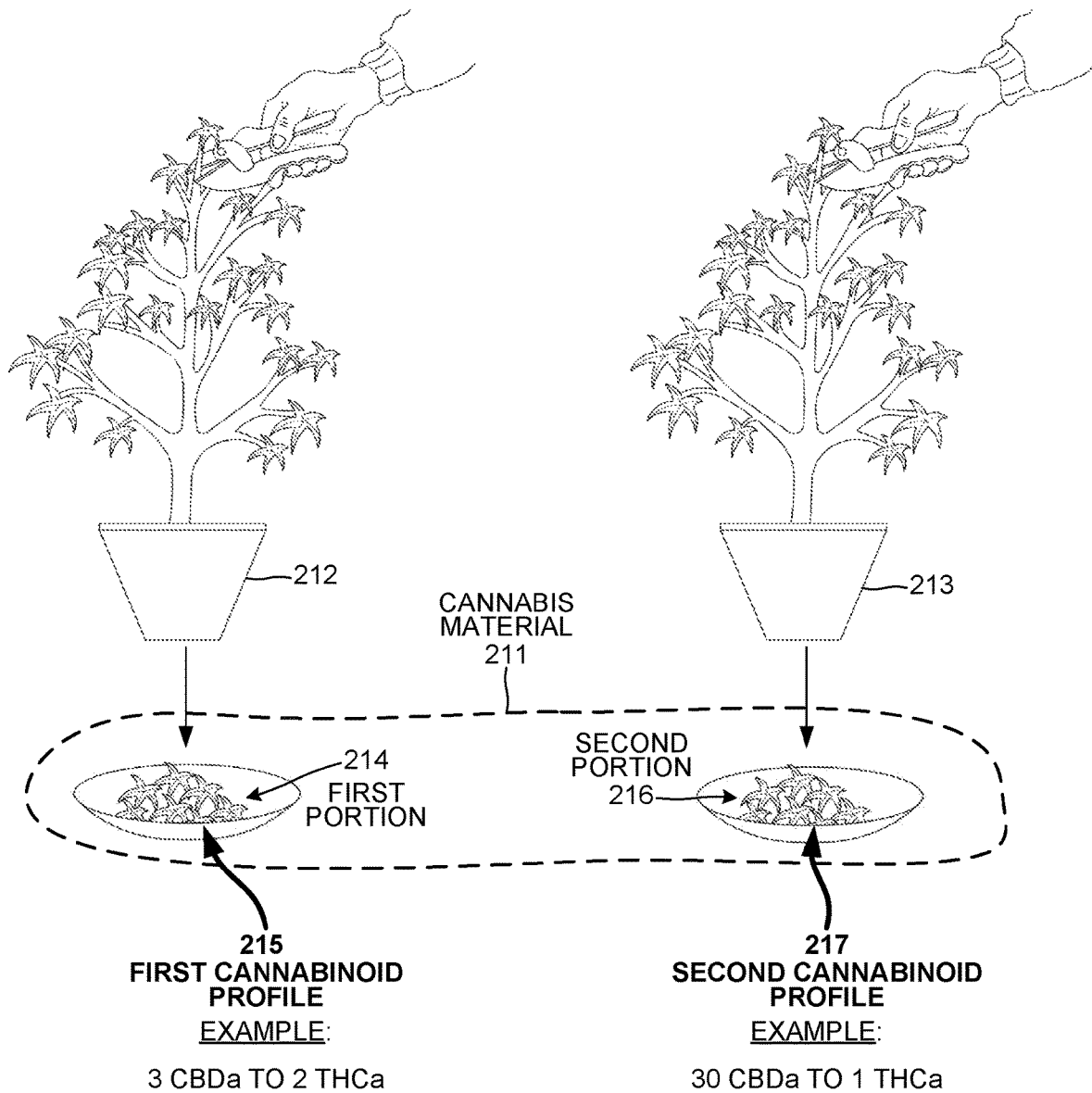

COLLECTING RAW CANNABIS MATERIAL

FIG. 13

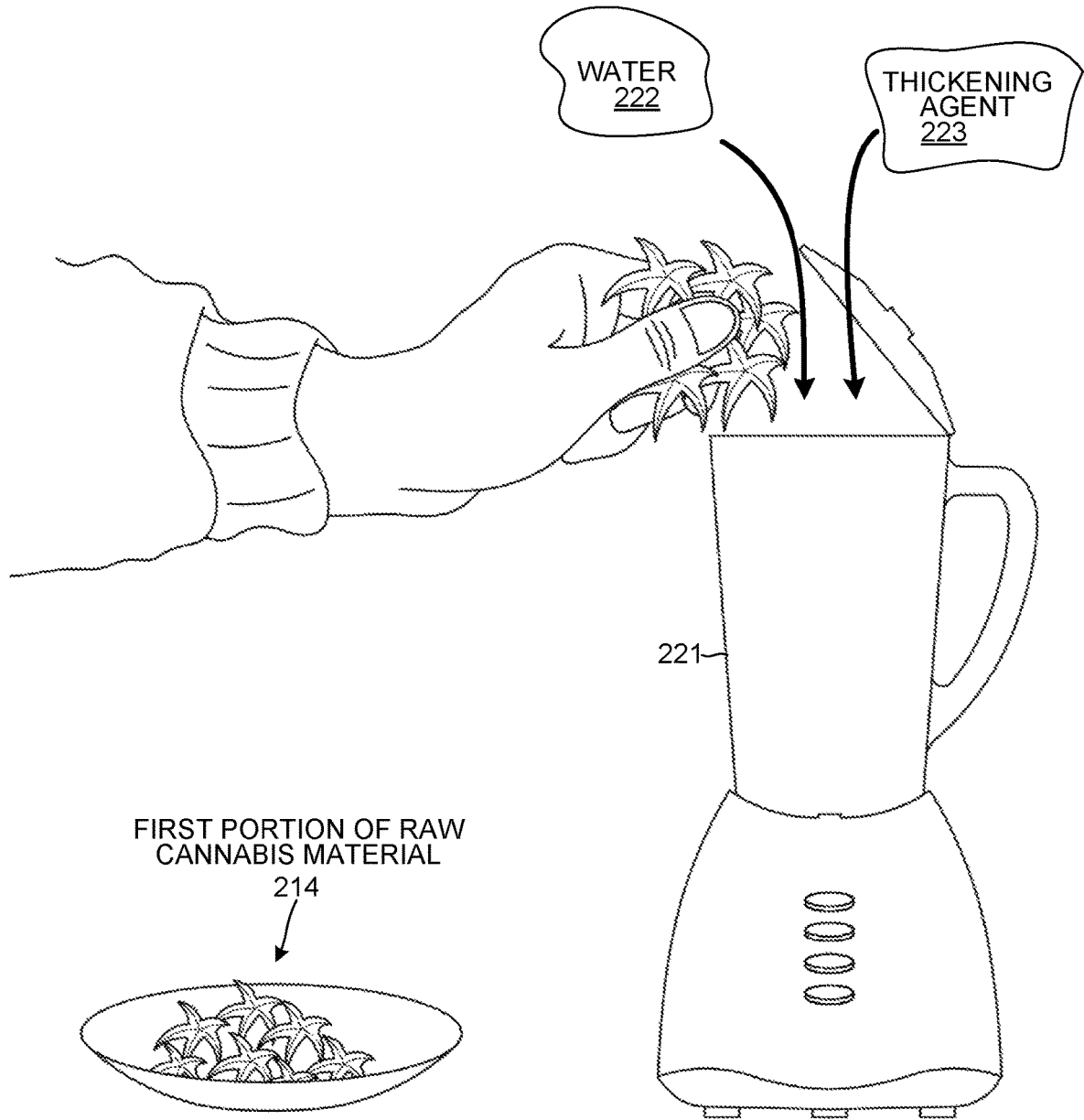

FORMING A CANNABIS JUICE PURÉE
FIG. 14

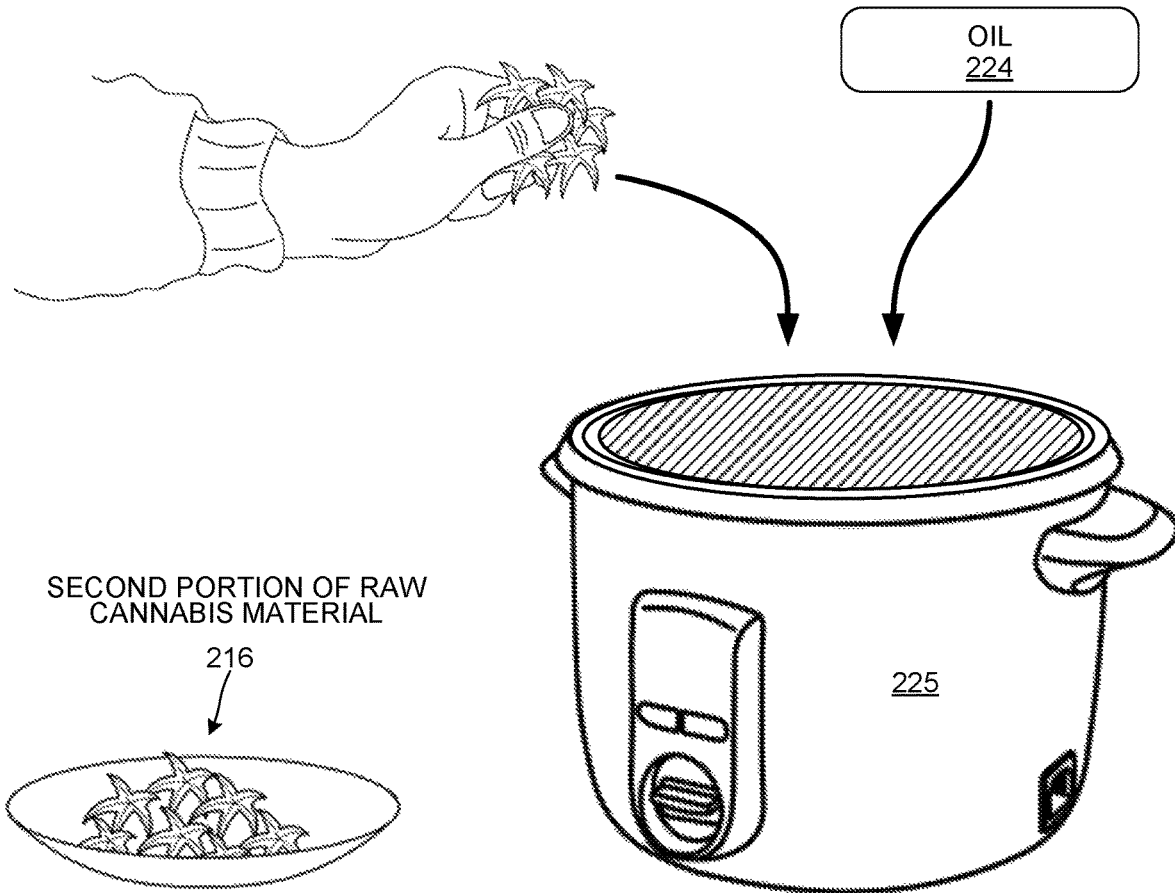

FORMING A DECARBOXYLATED CANNABIS
INFUSION INVOLVING OIL

FIG. 15

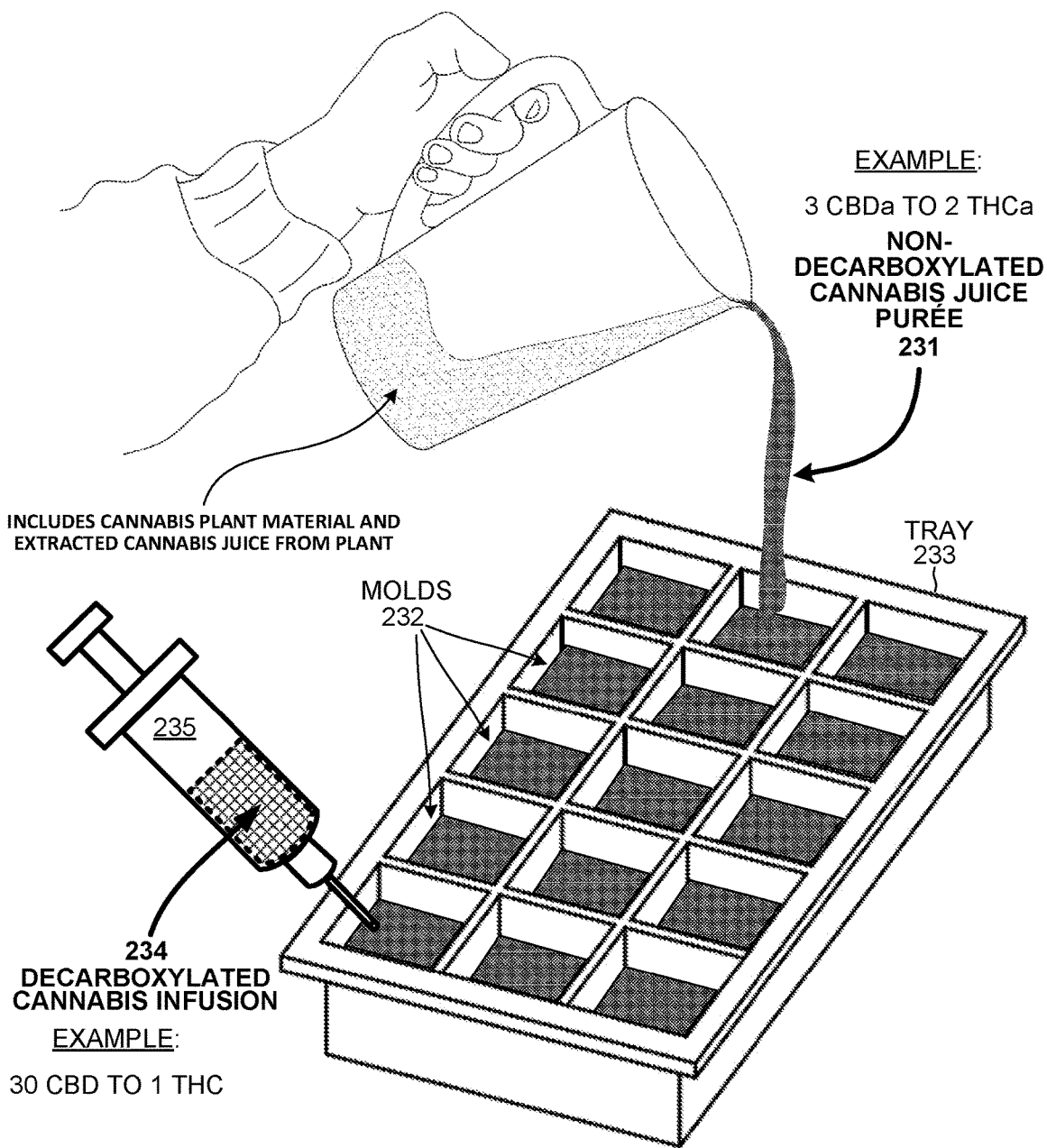

DEPOSITING THE NON-DECARBOXYLATED CANNABIS JUICE PURÉE AND THE DECARBOXYLATED CANNABIS INFUSION INTO MOLDS OF A TRAY

FIG. 16

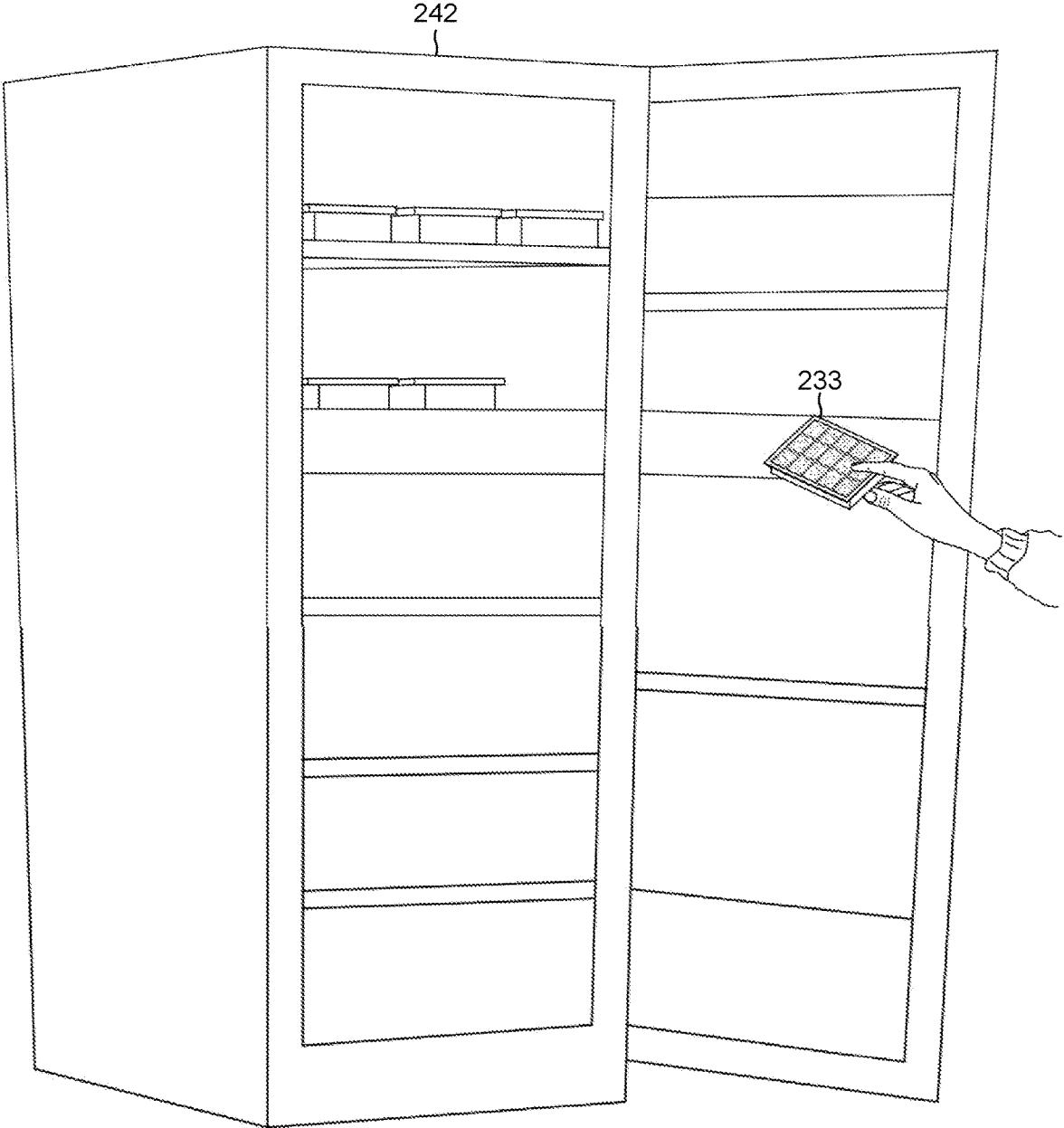

FREEZING THE TRAY OF MOLDS

FIG. 17

JN-001-1D-2C

18/52

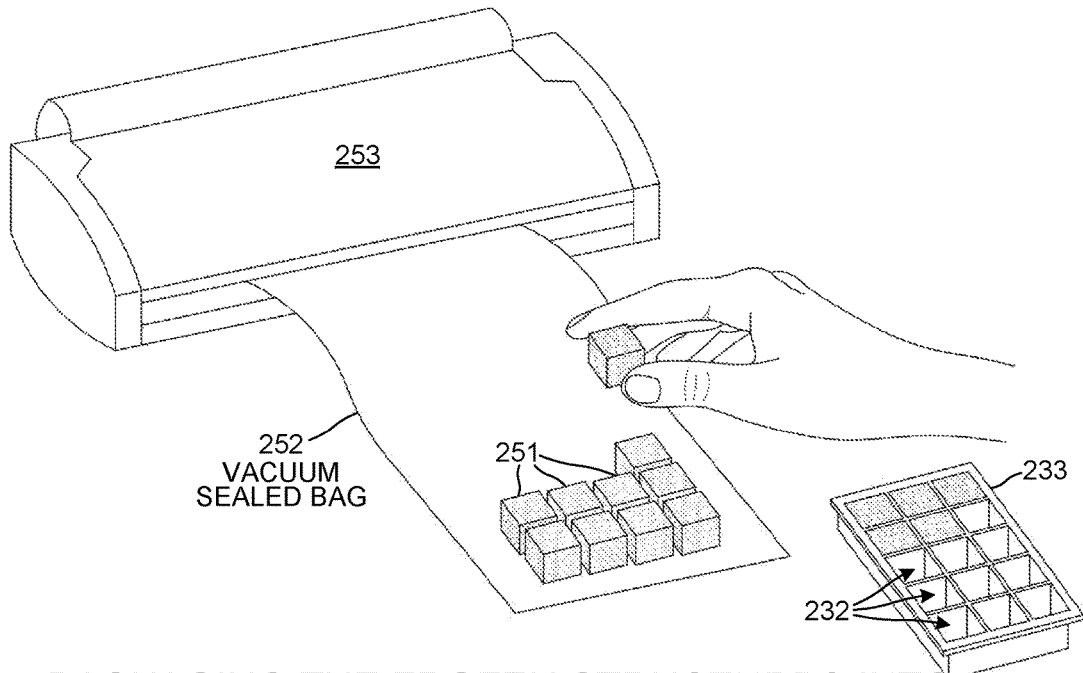

PACKAGING THE FROZEN STRUCTURES INTO A PACKAGE

FIG. 18

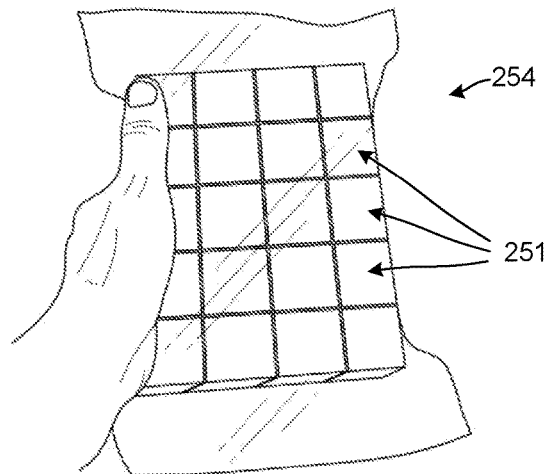

PACKAGE WITH FROZEN STRUCTURES OF CANNABIS JUICE PURÉE HAVING NON-DECARBOXYLATED AND DECARBOXYLATED CANNABINOIDS

FIG. 19

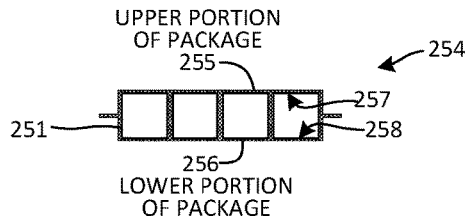

PACKAGE WITH FROZEN STRUCTURES OF CANNABIS JUICE PURÉE HAVING NON-DECARBOXYLATED AND DECARBOXYLATED CANNABINOIDS (SIDE VIEW)

FIG. 20

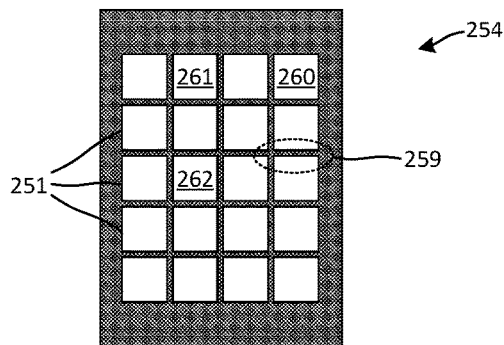

PACKAGE WITH FROZEN STRUCTURES OF CANNABIS JUICE PURÉE HAVING NON-DECARBOXYLATED AND DECARBOXYLATED CANNABINOIDS (TOP VIEW)

FIG. 21

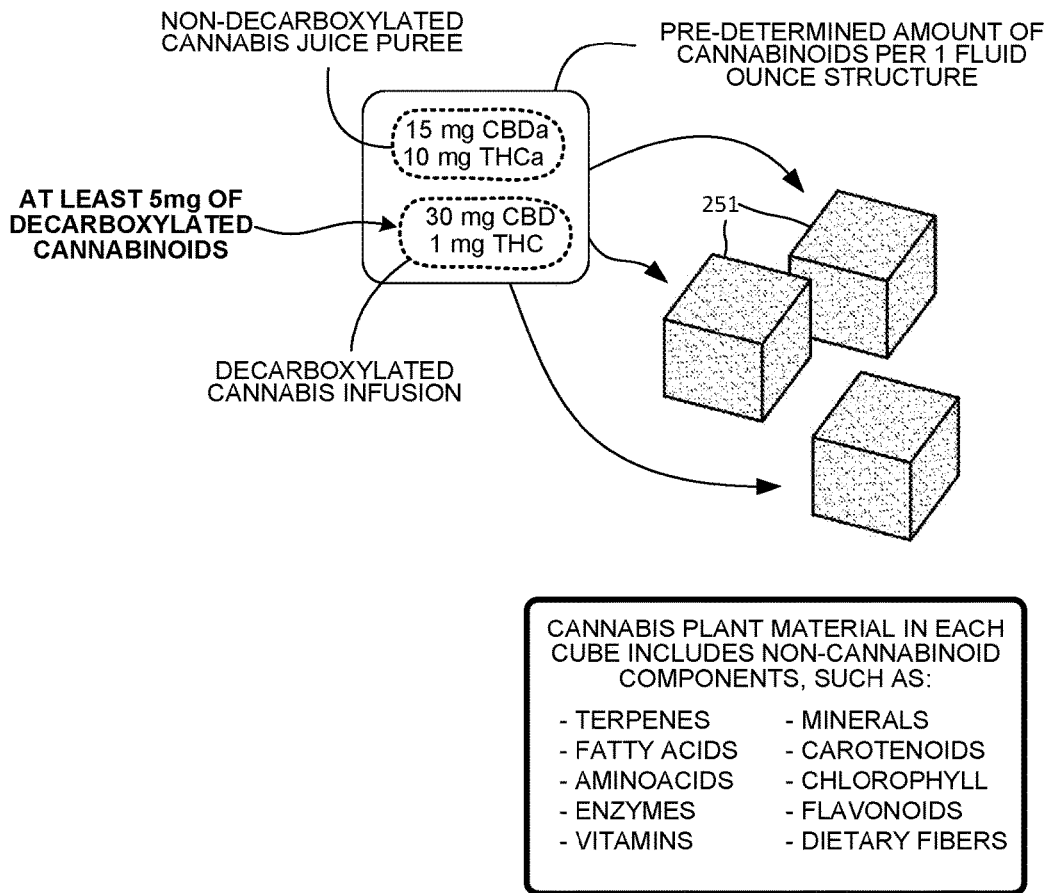

FROZEN STRUCTURES OF NON-DECARBOXYLATED CANNABIS JUICE PURÉE WITH ADDED DECARBOXYLATED CANNABIS INFUSION

FIG. 22A

PRE-DETERMINED AMOUNT OF CANNABINOIDS IN EACH STRUCTURE

FROM RAW CANNABIS PLANT:		FROM DECARBOXYLATED CANNABIS INFUSION:		FROM NON-DECARBOXYLATED HIGH CONCENTRATE CANNABIS EXTRACT (KIEF):	
THCa	10 mg/cube	THC	1 mg/cube	THCa	200 mg/cube
CBDa	15 mg/cube	CBD	30 mg/cube	CBDa	300 mg/cube
TOTAL FROM RAW CANNABIS:	25 mg/cube	TOTAL FROM DECARB. CANNABIS INFUSION:	31 mg/cube	TOTAL FROM NON-DECARB. KIEF:	500 mg/cube

AMOUNT OF ADDED NON-DECARBOXYLATED HIGH CONCENTRATE CANNABIS EXTRACT SUBSTANTIALLY INCREASES THE AMOUNT OF NON-DECARBOXYLATED CANNABINOIDS PER STRUCTURE

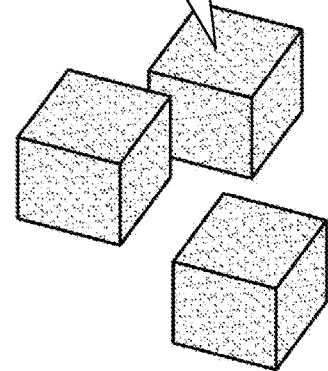

FROZEN STRUCTURES OF NON-DECARBOXYLATED CANNABIS JUICE PURÉE WITH ADDED DECARBOXYLATED CANNABIS INFUSION AND NON-DECARBOXYLATED HIGH CONCENTRATE CANNABIS EXTRACT (ALTERNATE EMBODIMENT)

FIG. 22B

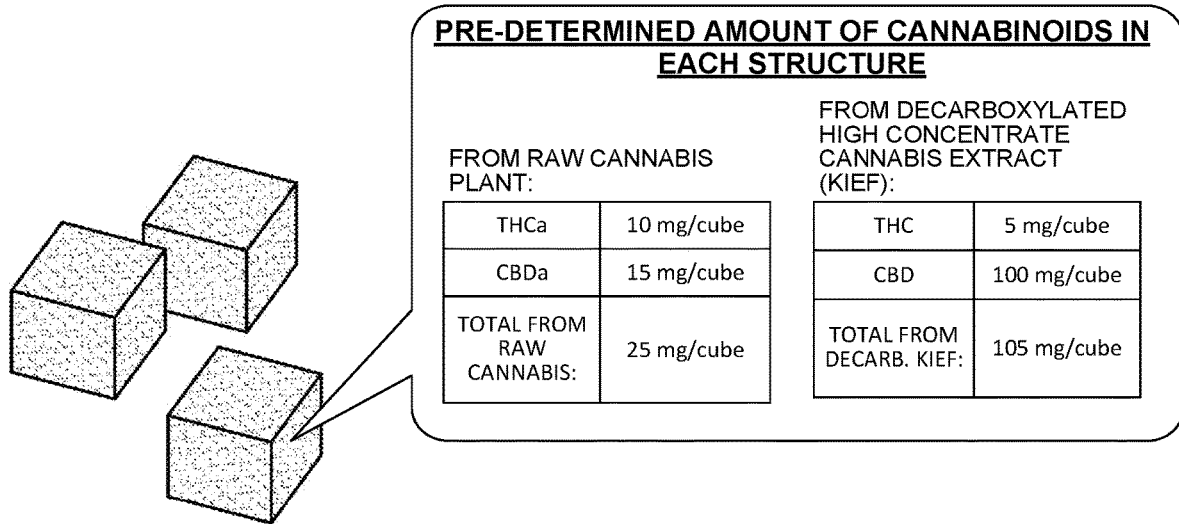

FROZEN STRUCTURES OF NON-DECARBOXYLATED CANNABIS JUICE PURÉE WITH ADDED DECARBOXYLATED HIGH CONCENTRATE CANNABIS EXTRACT (ALTERNATE EMBODIMENT)

FIG. 22C

PRE-DETERMINED AMOUNT OF CANNABINOIDS IN EACH STRUCTURE

FROM RAW CANNABIS PLANT:

THCa	10 mg/cube
CBDa	15 mg/cube
TOTAL FROM RAW CANNABIS:	25 mg/cube

FROM DECARBOXYLATED HIGH CONCENTRATE CANNABIS EXTRACT (KIEF):

THC	5 mg/cube
CBD	100 mg/cube
TOTAL FROM DECARB. KIEF:	105 mg/cube

FROM NON-DECARBOXYLATED HIGH CONCENTRATE CANNABIS EXTRACT (KIEF):

THCa	200 mg/cube
CBDa	300 mg/cube
TOTAL FROM NON-DECARB. KIEF:	500 mg/cube

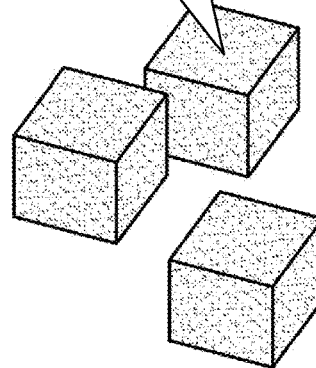

FROZEN STRUCTURES OF NON-DECARBOXYLATED CANNABIS JUICE PURÉE WITH ADDED NON-DECARBOXYLATED AND DECARBOXYLATED HIGH CONCENTRATE CANNABIS EXTRACT

(ALTERNATE EMBODIMENT)

FIG. 22D

263

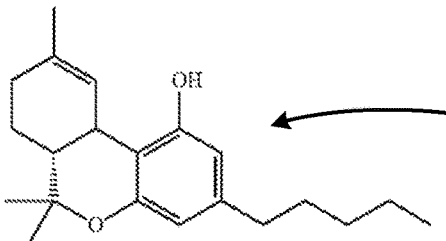
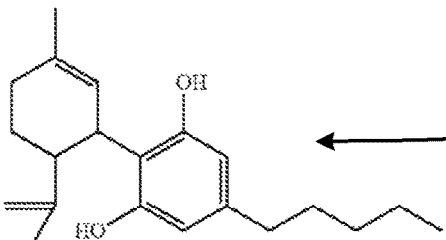
TYPE	STRUCTURAL FORMULA
TETRAHYDROCANNABINOL (THC)	
CANNABIDIOL (CBD)	

DECARBOXYLATION REMOVES CARBOXYL GROUP

EXAMPLES OF DECARBOXYLATED CANNABINOIDS
FIG. 23

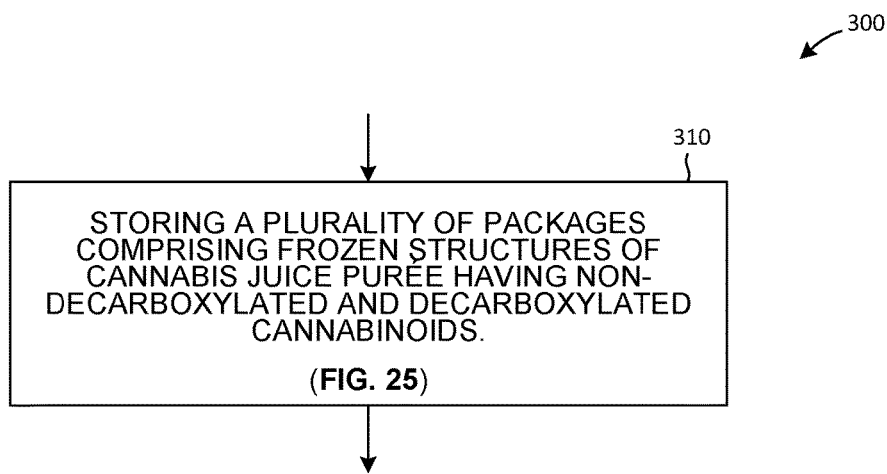
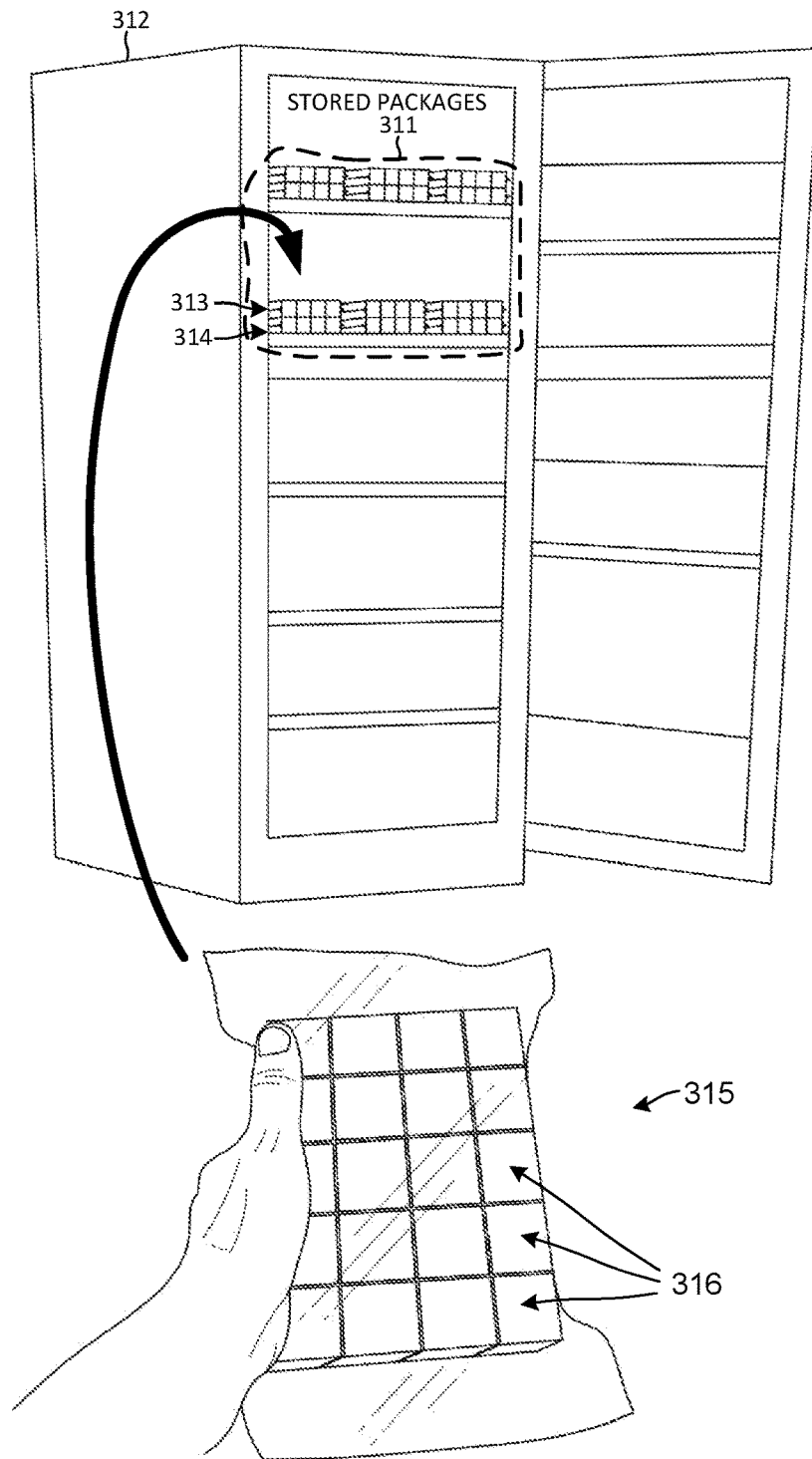
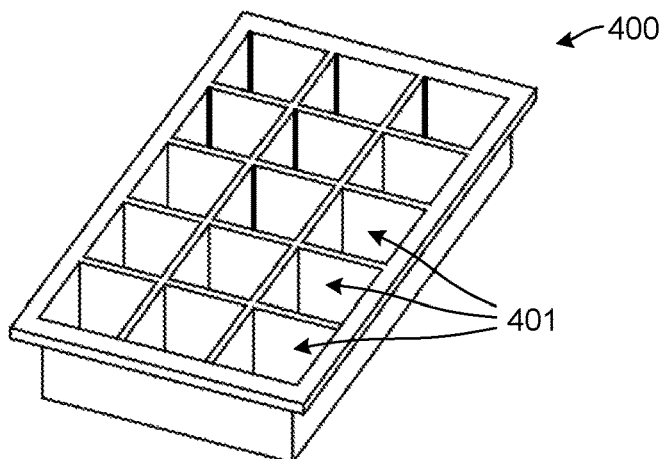

FIG. 24



STORING PACKAGED STRUCTURES OF FROZEN
CANNABIS JUICE PURÉE HAVING NON-
DECARBOXYLATED AND DECARBOXYLATED
CANNABINOIDS

FIG. 25



CUBE-SHAPED MOLD TRAY
(PERSPECTIVE VIEW)
FIG. 26

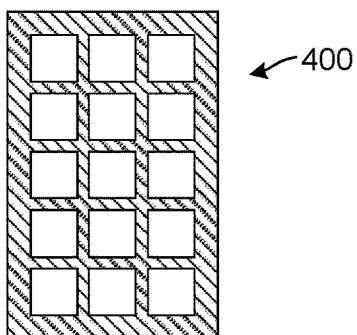

CUBE SHAPED
MOLD TRAY
(TOP VIEW)
FIG. 27

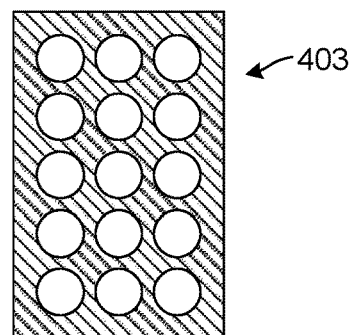

CYLINDRICAL SHAPED
MOLD TRAY
(TOP VIEW)
FIG. 28

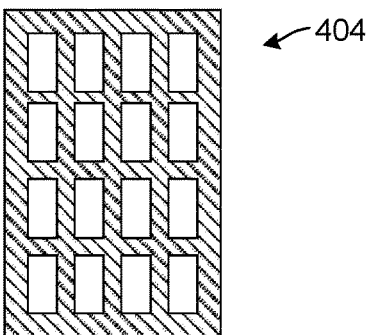

RECTANGULAR
SHAPED MOLD TRAY
(TOP VIEW)
FIG. 29

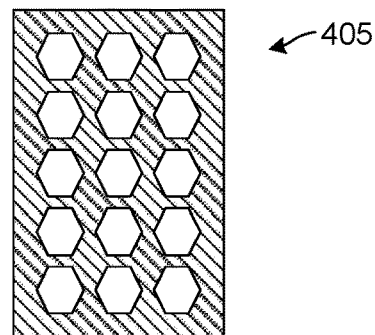

HEXAGONAL SHAPED
MOLD TRAY
(TOP VIEW)
FIG. 30

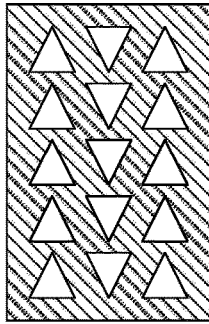

406

TRIANGULAR-SHAPED
MOLD TRAY
(TOP VIEW)
FIG. 31

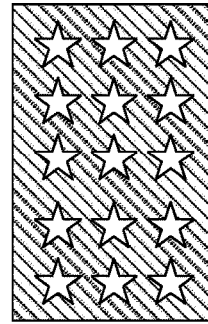

407

STAR-SHAPED MOLD
TRAY
(TOP VIEW)
FIG. 32

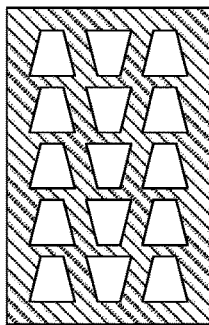

408

TRAPEZOIDAL-
SHAPED MOLD TRAY
(TOP VIEW)
FIG. 33

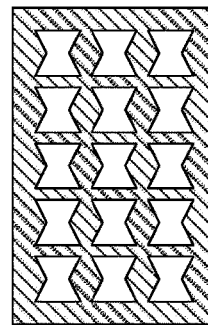

409

CONCAVE-SHAPED
MOLD TRAY
(TOP VIEW)
FIG. 34

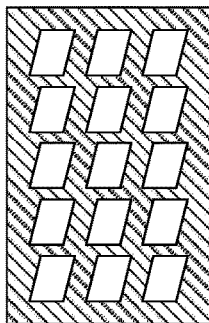

410

PARALLELOGRAM-
SHAPED MOLD TRAY
(TOP VIEW)
FIG. 35

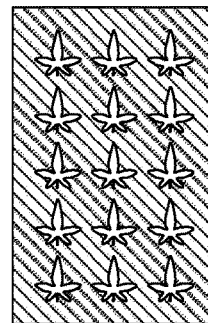

411

LEAF-SHAPED MOLD TRAY
(TOP VIEW)
FIG. 36

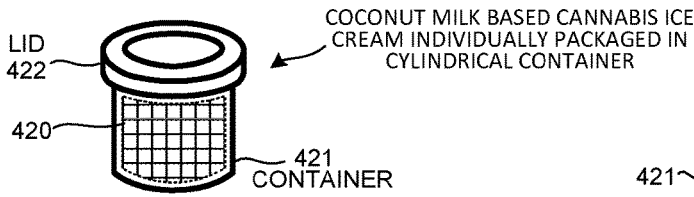

COCONUT MILK BASED
CANNABIS ICE CREAM PACK
FIG. 37

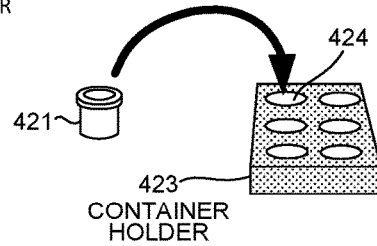

FIG. 38

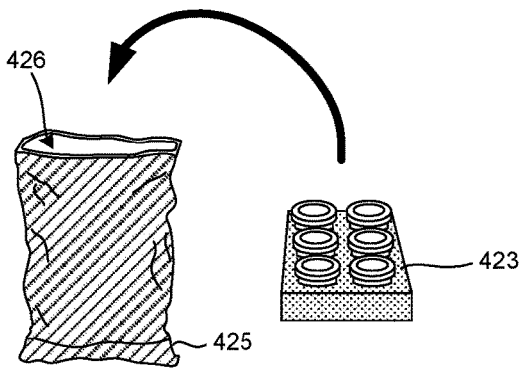
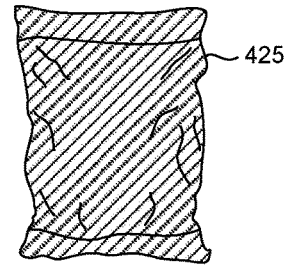

FIG. 39



PACKAGED COCONUT MILK BASED
CANNABIS ICE CREAM PACKS
FIG. 40

500

	STORAGE CAPACITY	PACKAGING COSTS	WASTE GENERATION	QUANTITY PER PACKAGE
NOVEL PACKAGE WITH PELLETS (FIGS. 7 AND 19)	MINIMAL PACKAGES SAME SHAPE STACKING EFFICIENTLY	MINIMAL VACUUM SEAL PELLETS IN BAG	MINIMAL ONLY WASTE IS VACUUM SEAL BAG	20 PELLETS
CONVENTIONAL PACKAGE WITH COCONUT MILK BASED CANNABIS ICE CREAM PACKS (FIG. 40)	SIGNIFICANT SPACE REQUIRED PACKAGE HAS OBTUSE SHAPE	SUBSTANTIAL PACKAGING COSTS 1) PACK EACH ICE CREAM IN INDIVIDUAL CONTAINER 2) MATERIAL COSTS FOR CONTAINERS, LIDS, HOLDER, AND OUTER PACKAGE	ADDITIONAL WASTE 1) 6 CONTAINERS 2) 6 LIDS 3) HOLDER 4) OUTER PACKAGE	6 CANNABIS ICE CREAMS

FIG. 41

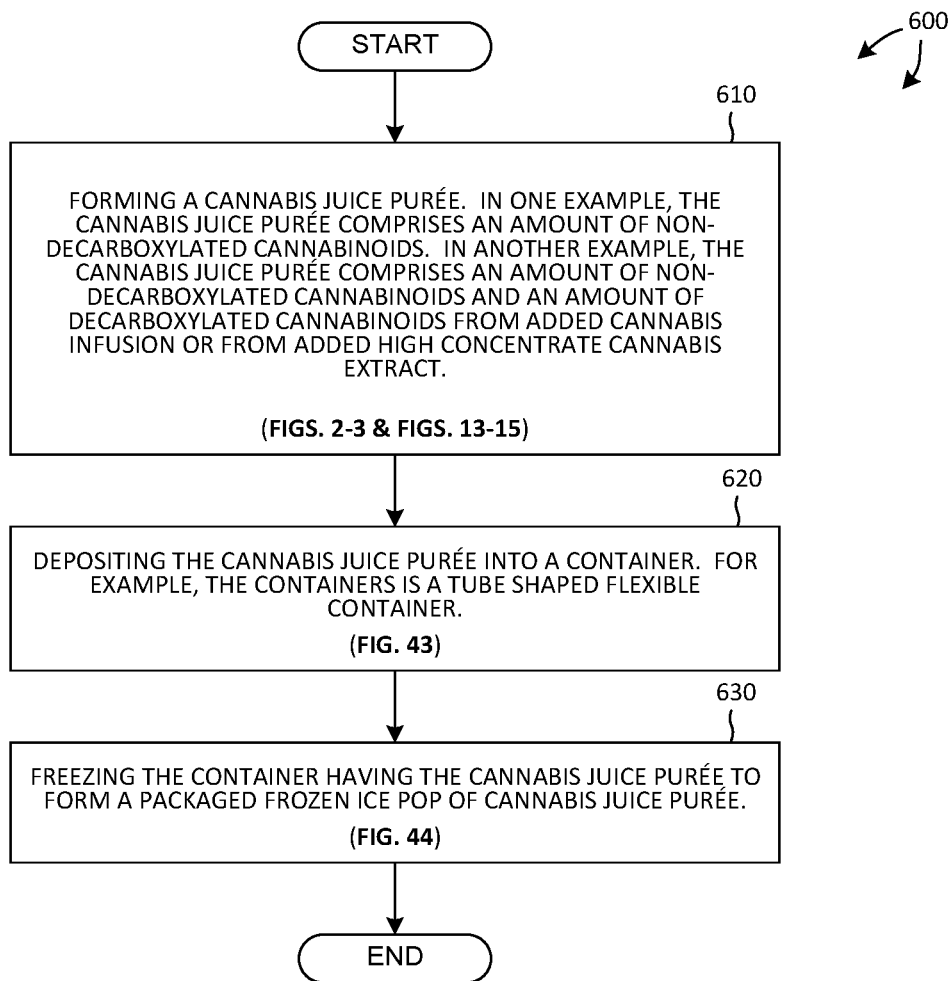

MANUFACTURING AND PACKAGING
FROZEN ICE POPS OF CANNABIS JUICE PURÉE
(THIRD EMBODIMENT)

FIG. 42

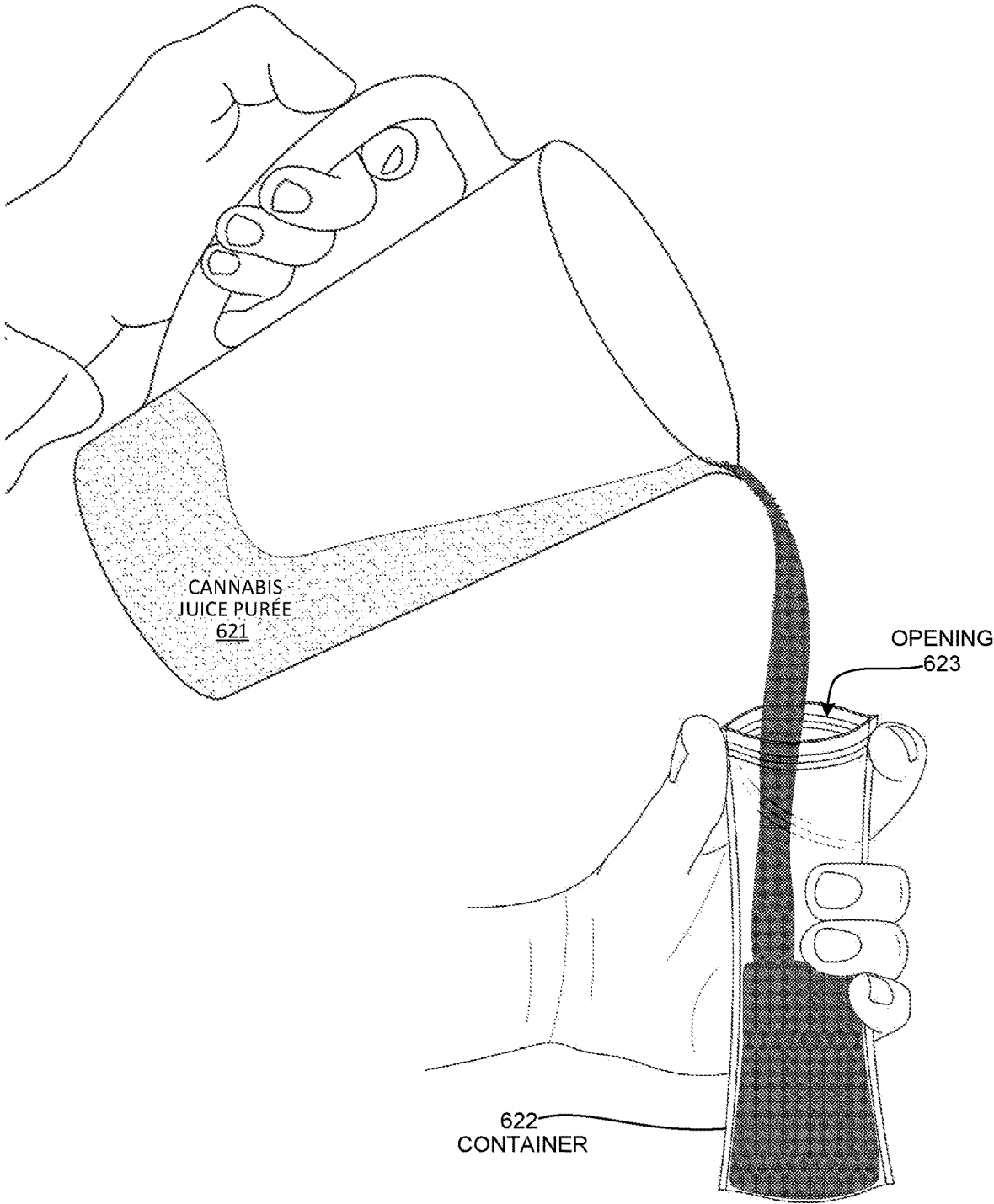

DEPOSITING THE CANNABIS JUICE PURÉE INTO A CONTAINER

FIG. 43

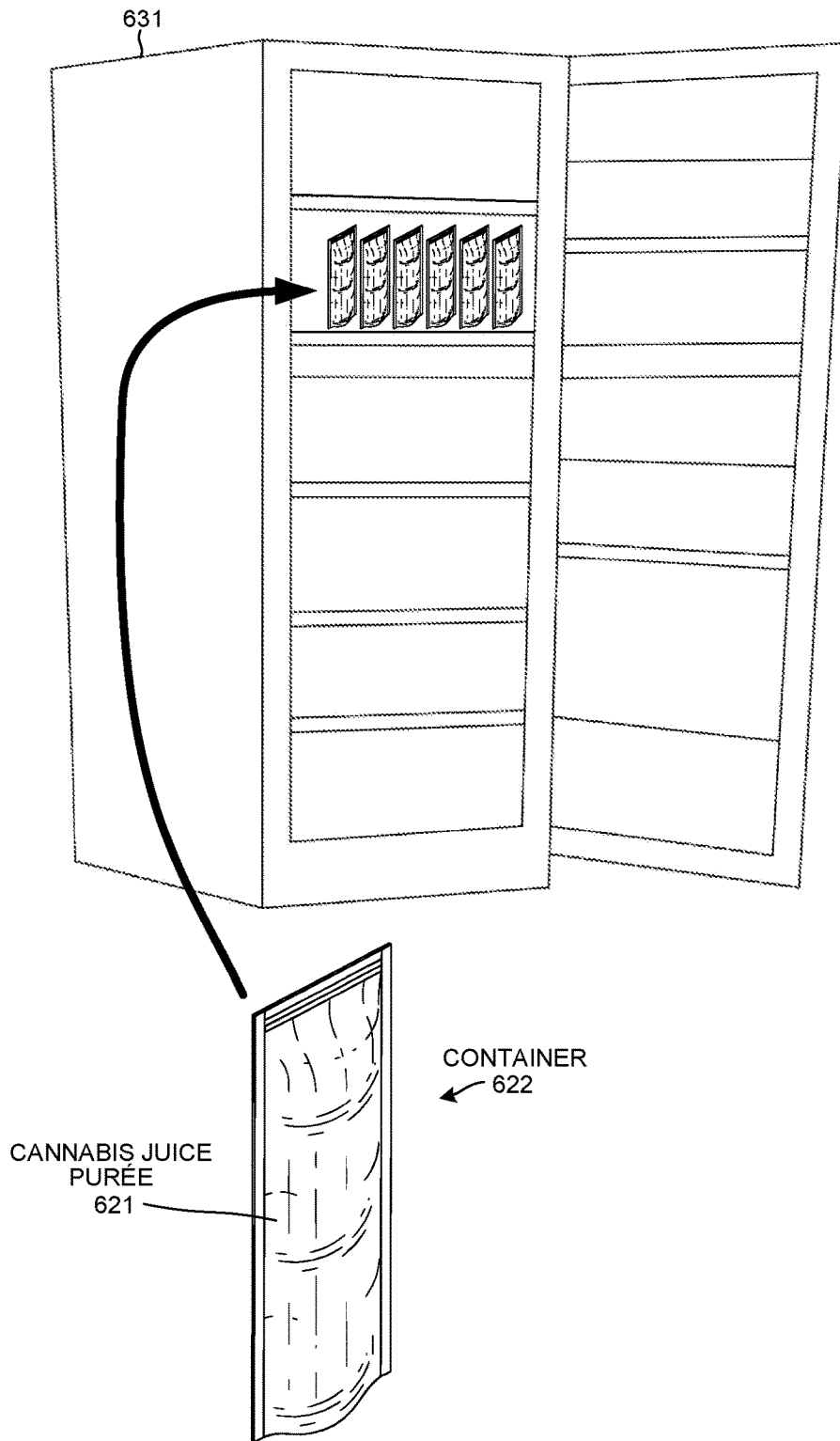

FREEZING THE CONTAINER TO FORM A PACKAGED
FROZEN ICE POP OF CANNABIS JUICE PURÉE

FIG. 44

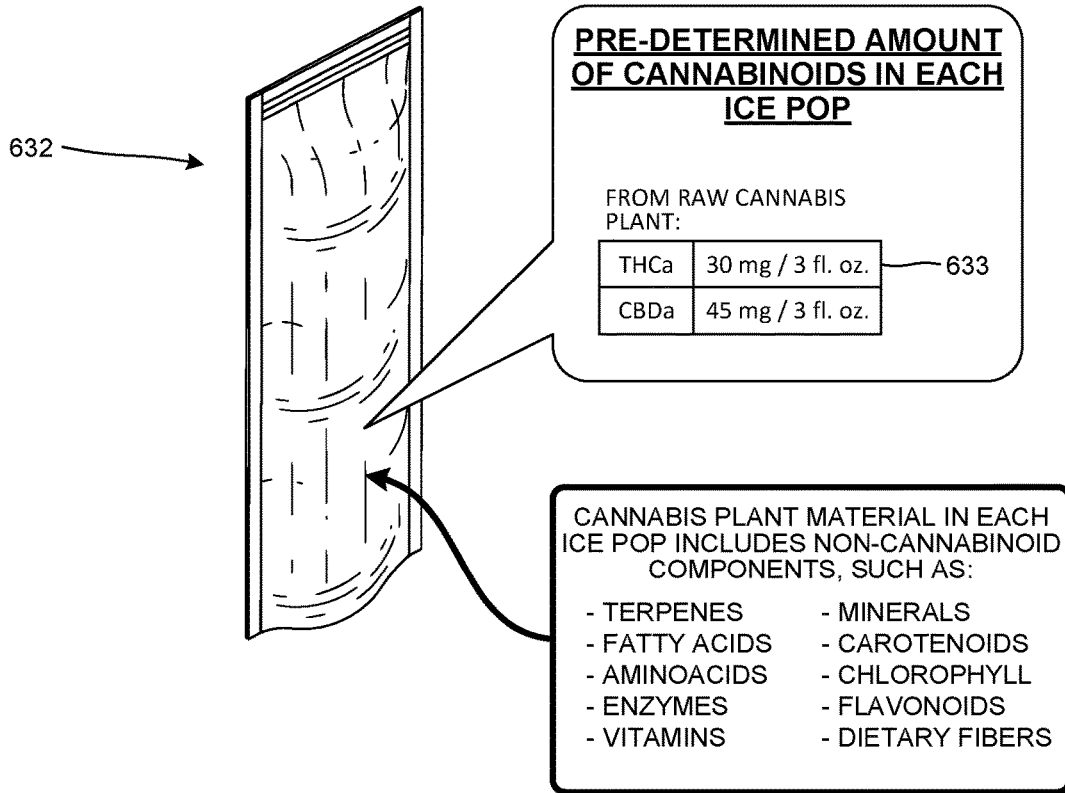

PACKAGED FROZEN ICE POP OF CANNABIS JUICE PURÉE (WITHOUT DECARBOXYLATED CANNABINOIDS)

FIG. 45A

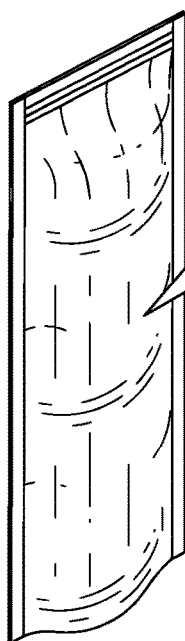

PRE-DETERMINED AMOUNT OF CANNABINOIDS IN EACH ICE POP

FROM RAW CANNABIS PLANT:		FROM NON-DECARBOXYLATED HIGH CONCENTRATE CANNABIS EXTRACT (KIEF):	
THCa	30 mg / 3 fl. oz.	THCa	600 mg / 3 fl. oz.
CBDa	45 mg / 3 fl. oz.	CBDa	900 mg / 3 fl. oz.
TOTAL FROM RAW CANNABIS:	75 mg / 3 fl. oz.	TOTAL FROM NON-DECARB. KIEF:	1,500 mg / 3 fl. oz.

PACKAGED FROZEN ICE POP OF CANNABIS JUICE PURÉE WITH ADDED NON-DECARBOXYLATED HIGH CONCENTRATE CANNABIS EXTRACT

(ALTERNATE EMBODIMENT)

FIG. 45B

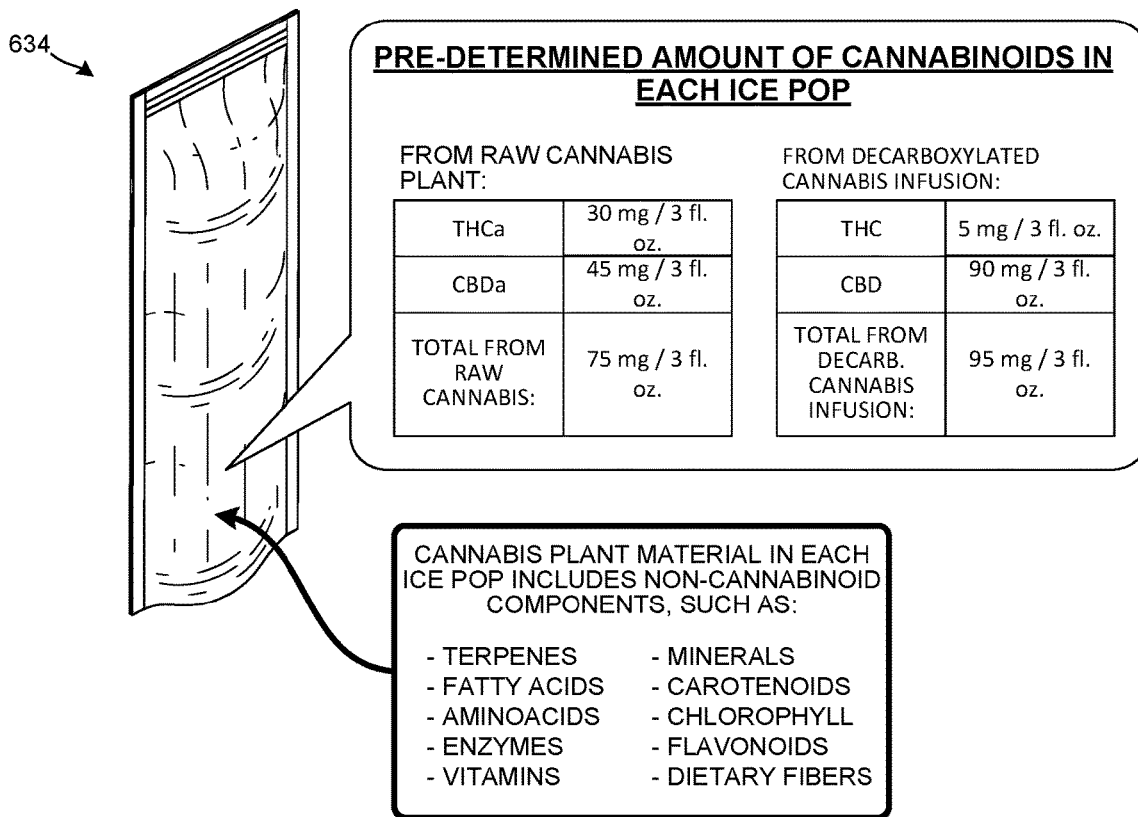

PACKAGED FROZEN ICE POP OF CANNABIS JUICE
 PURÉE WITH ADDED DECARBOXYLATED CANNABIS
 INFUSION
 (WITH DECARBOXYLATED CANNABINOIDS)
FIG. 46A

PRE-DETERMINED AMOUNT OF CANNABINOIDS IN EACH ICE POP

FROM RAW CANNABIS PLANT:

THCa	30 mg / 3 fl. oz.
CBDa	45 mg / 3 fl. oz.
TOTAL FROM RAW CANNABIS:	75 mg / 3 fl. oz.

FROM DECARBOXYLATED CANNABIS INFUSION:

THC	5 mg / 3 fl. oz.
CBD	90 mg / 3 fl. oz.
TOTAL FROM DECARB. CANNABIS INFUSION:	95 mg / 3 fl. oz.

FROM NON-DECARBOXYLATED HIGH CONCENTRATE CANNABIS EXTRACT (KIEF):

THCa	600 mg / 3 fl. oz.
CBDa	900 mg / 3 fl. oz.
TOTAL FROM NON-DECARB. KIEF:	1,500 mg / 3 fl. oz.

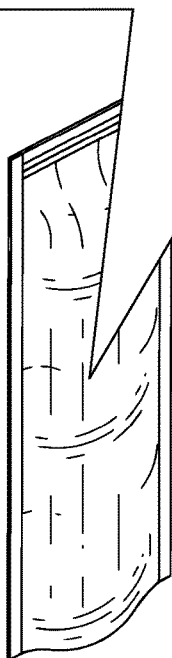

PACKAGED FROZEN ICE POP OF CANNABIS JUICE PURÉE WITH ADDED DECARBOXYLATED CANNABIS INFUSION AND NON-DECARBOXYLATED HIGH CONCENTRATE CANNABIS EXTRACT
(ALTERNATE EMBODIMENT)

FIG. 46B

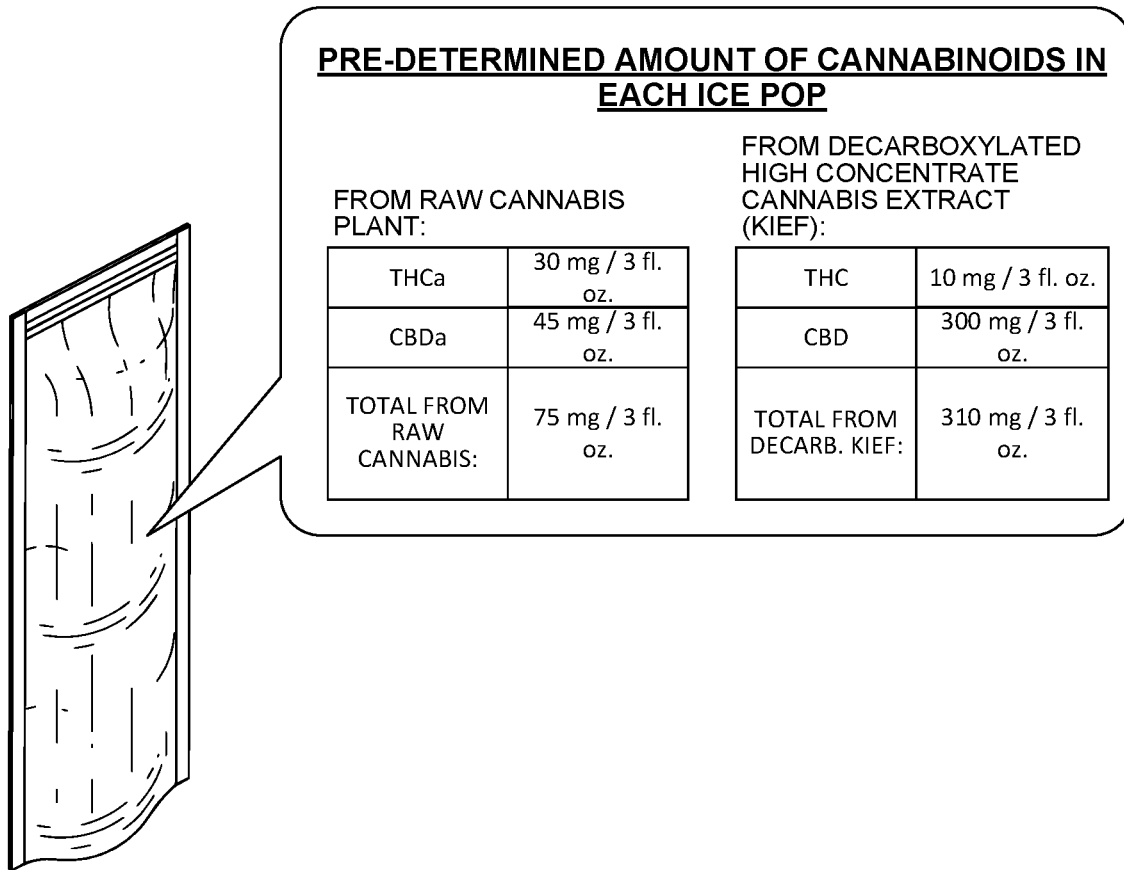

PACKAGED FROZEN ICE POP OF CANNABIS JUICE PURÉE WITH ADDED DECARBOXYLATED HIGH CONCENTRATE CANNABIS EXTRACT

(ALTERNATE EMBODIMENT)

FIG. 46C

PRE-DETERMINED AMOUNT OF CANNABINOIDS IN EACH ICE POP

FROM RAW CANNABIS PLANT:

THCa	30 mg / 3 fl. oz.
CBDa	45 mg / 3 fl. oz.
TOTAL FROM RAW CANNABIS:	75 mg / 3 fl. oz.

FROM DECARBOXYLATED HIGH CONCENTRATE CANNABIS EXTRACT (KIEF):

THC	10 mg / 3 fl. oz.
CBD	300 mg / 3 fl. oz.
TOTAL FROM DECARB. KIEF:	310 mg / 3 fl. oz.

FROM NON-DECARBOXYLATED HIGH CONCENTRATE CANNABIS EXTRACT (KIEF):

THCa	600 mg / 3 fl. oz.
CBDa	900 mg / 3 fl. oz.
TOTAL FROM NON-DECARB. KIEF:	1,500 mg / 3 fl. oz.

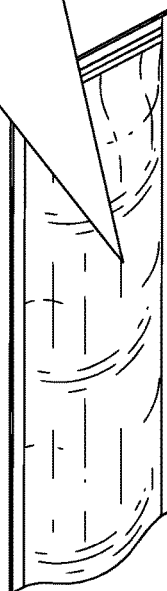

PACKAGED FROZEN ICE POP OF CANNABIS JUICE PURÉE WITH ADDED NON-DECARBOXYLATED AND DECARBOXYLATED HIGH CONCENTRATE CANNABIS EXTRACT

(ALTERNATE EMBODIMENT)

FIG. 46D

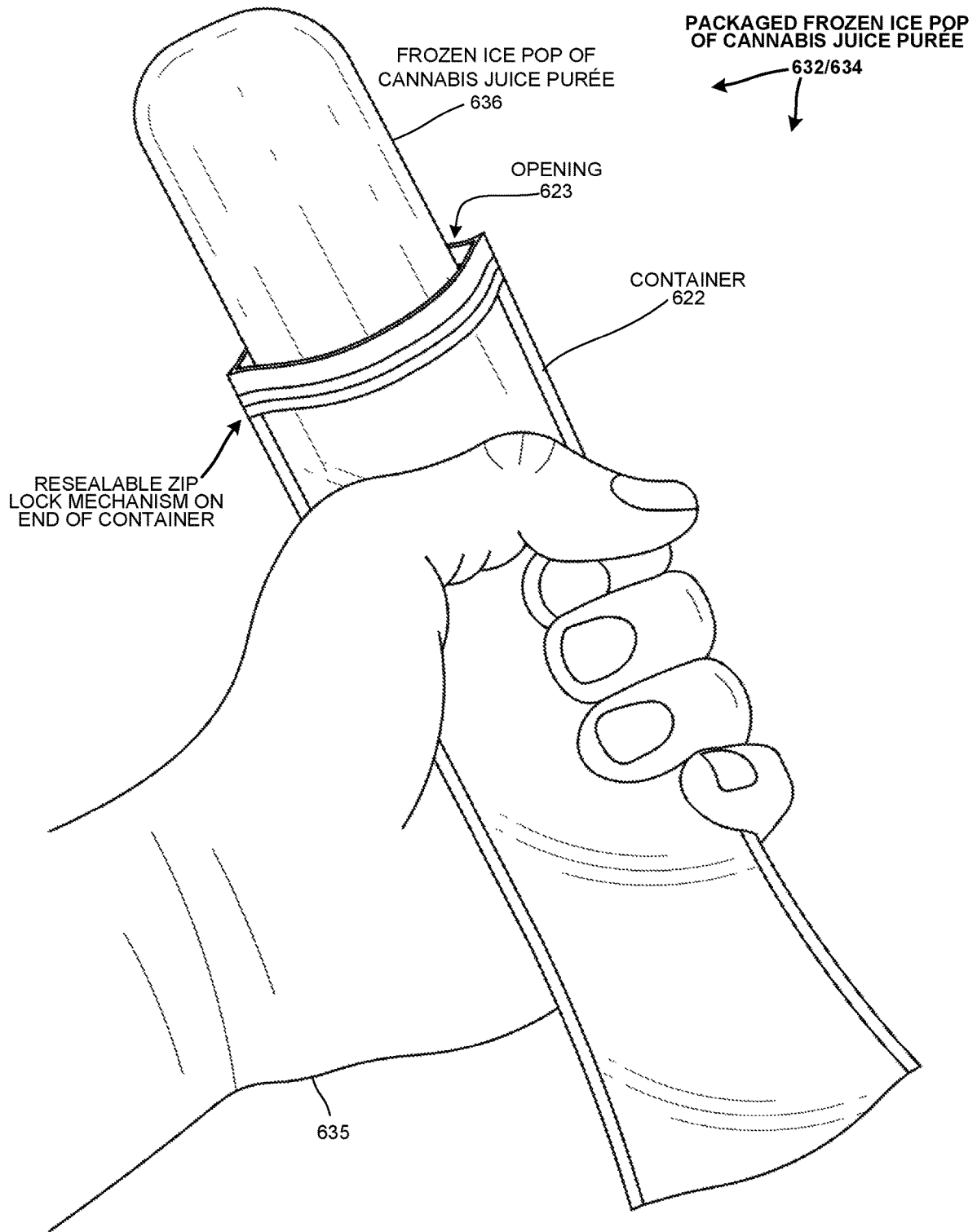
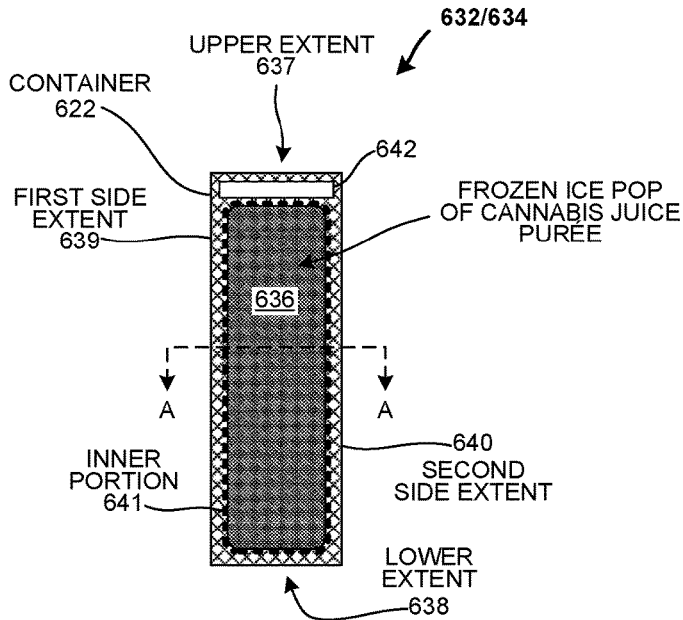
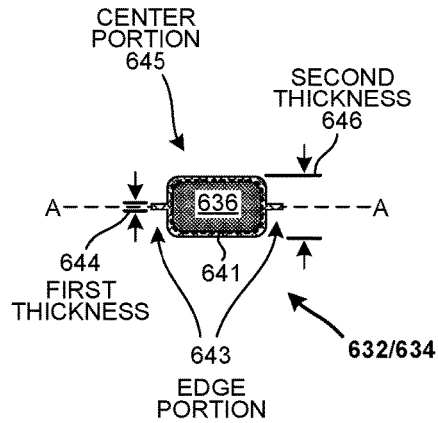

FIG. 47



SIDE VIEW OF PACKAGED FROZEN ICE POP OF CANNABIS JUICE PURÉE
FIG. 48



TOP VIEW OF PACKAGED FROZEN ICE POP OF CANNABIS JUICE PURÉE
FIG. 49

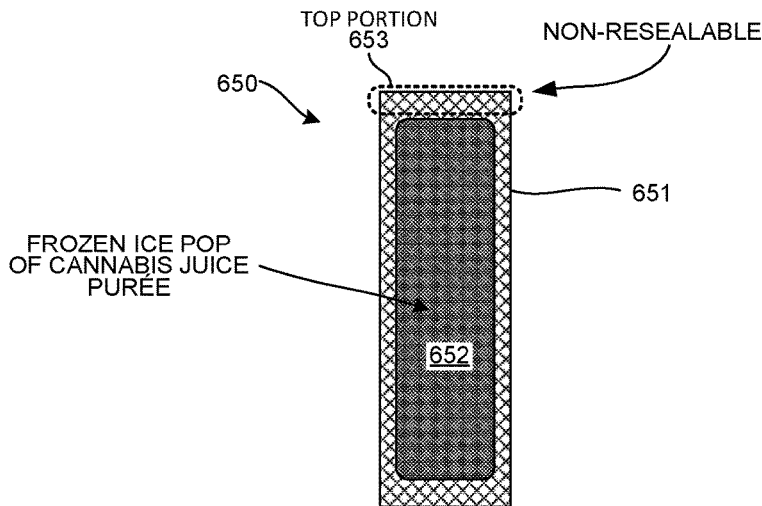

SIDE VIEW OF PACKAGED FROZEN ICE POP OF CANNABIS JUICE PURÉE
(ANOTHER EMBODIMENT)
FIG. 50

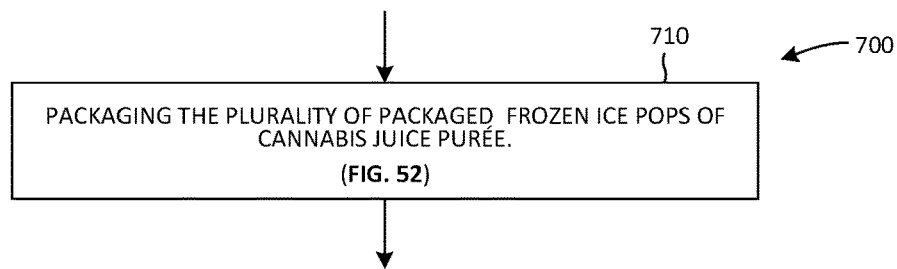
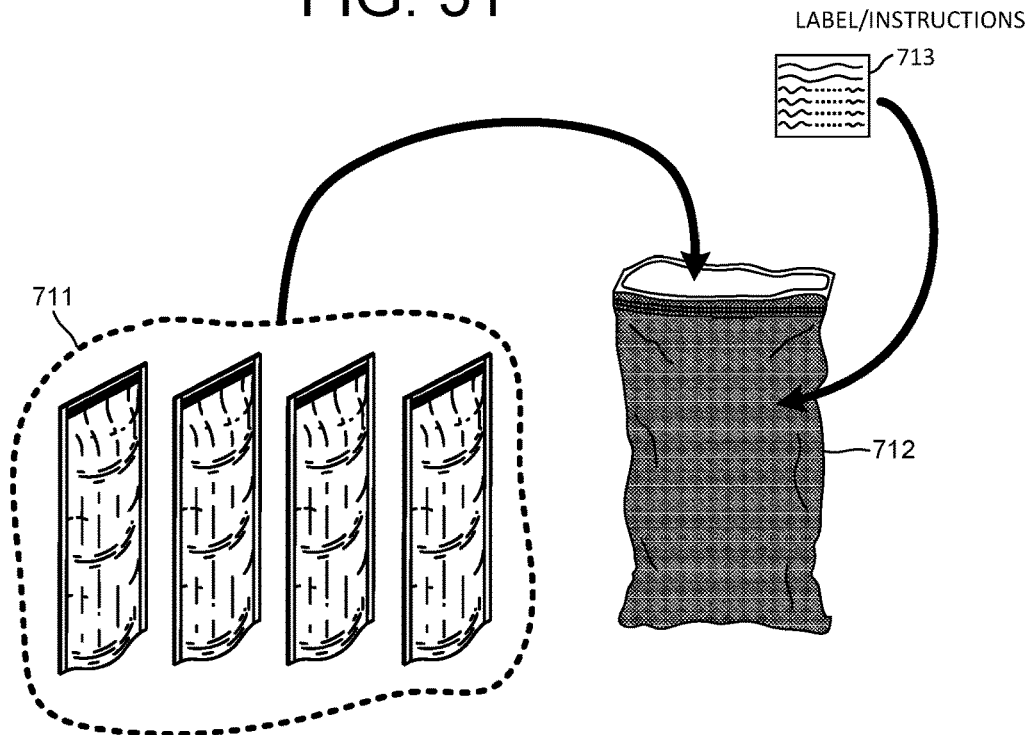

FIG. 51



PACKAGING THE PLURALITY OF PACKAGED FROZEN ICE POPS OF CANNABIS JUICE PURÉE

FIG. 52

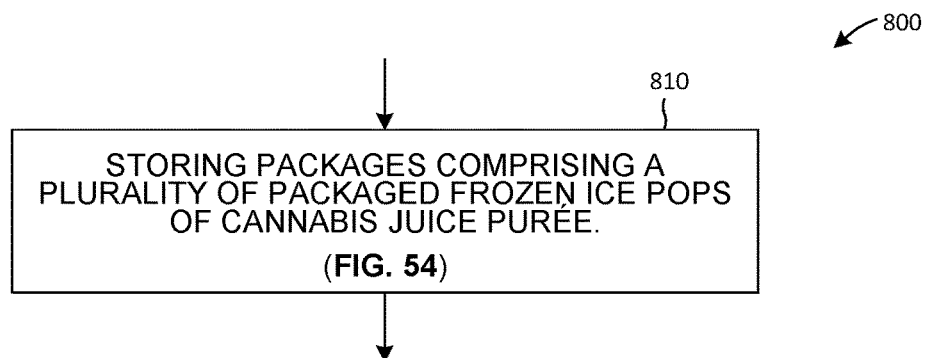
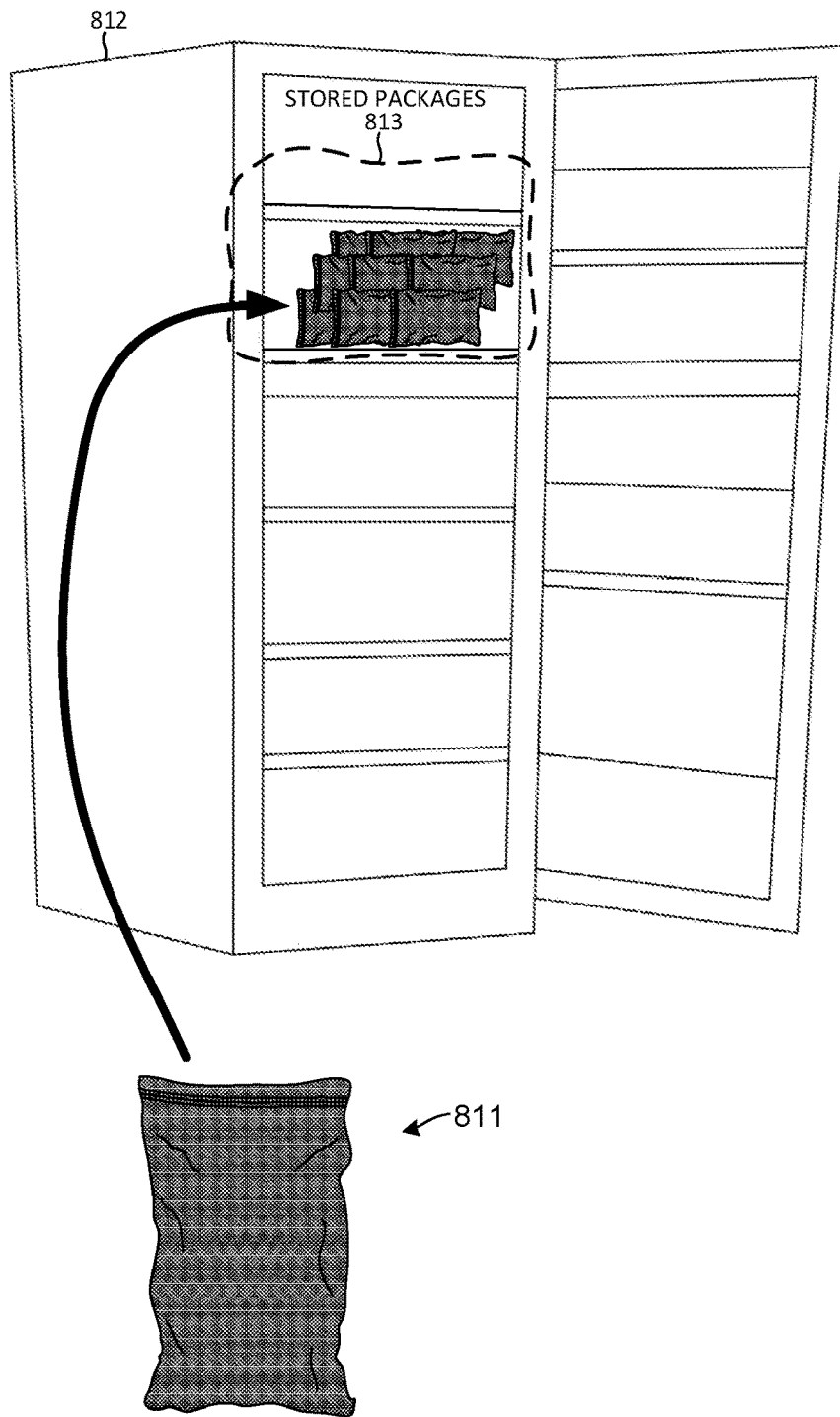
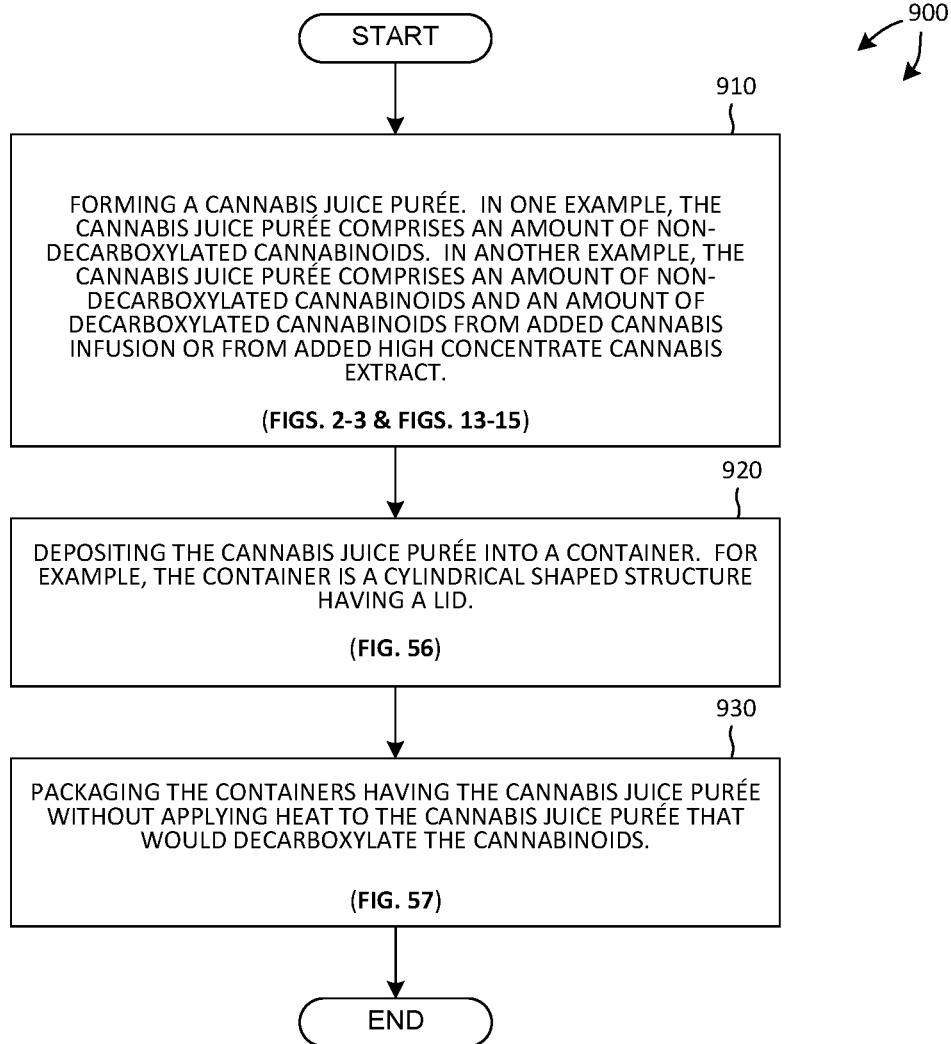

FIG. 53



STORING PACKAGES HAVING THE PACKAGED
FROZEN ICE POPS OF CANNABIS JUICE PURÉE

FIG. 54



MANUFACTURING AND PACKAGING
CANNABIS JUICE PURÉE
(FOURTH EMBODIMENT)

FIG. 55

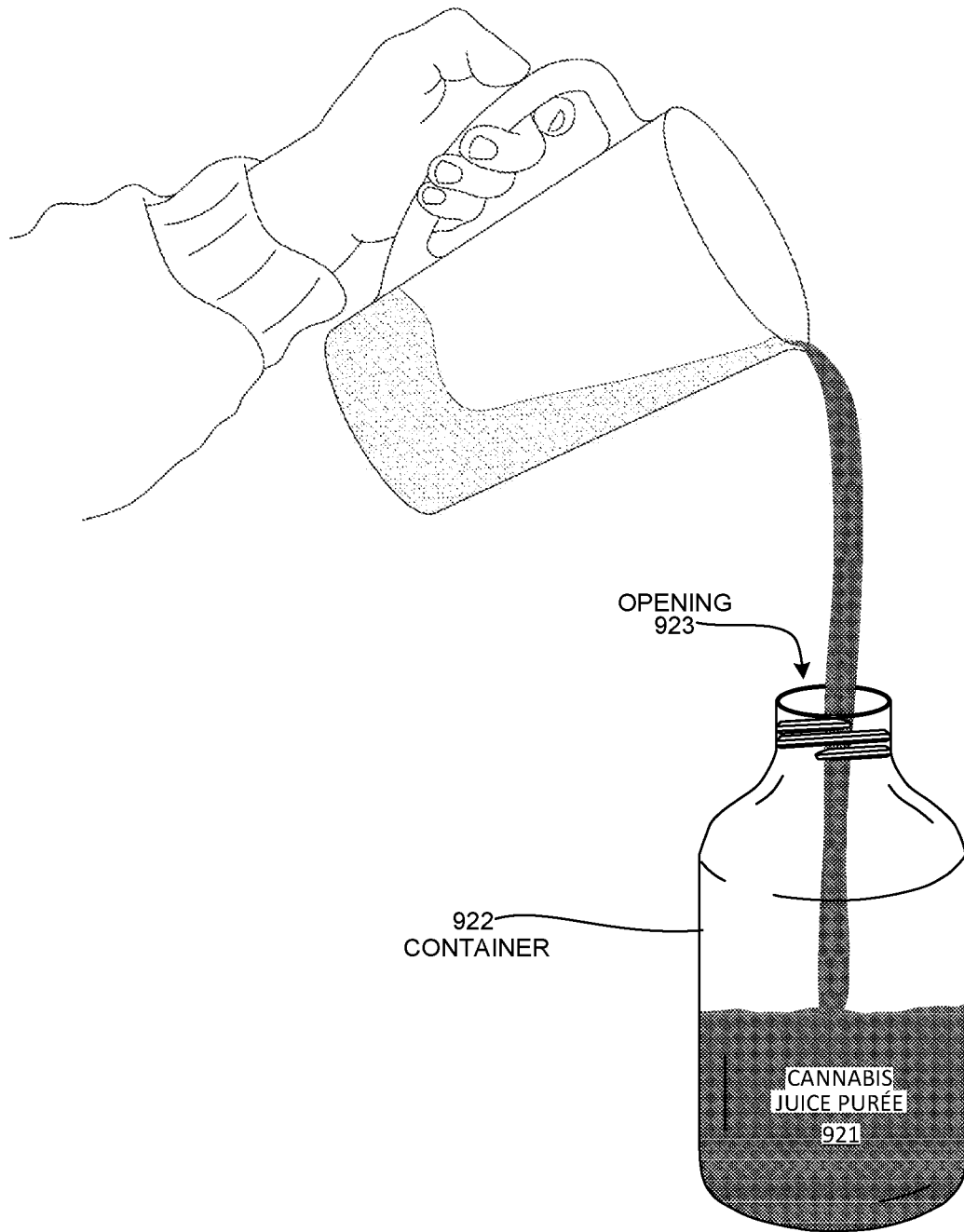

DEPOSITING THE CANNABIS JUICE PURÉE
INTO A CONTAINER

FIG. 56

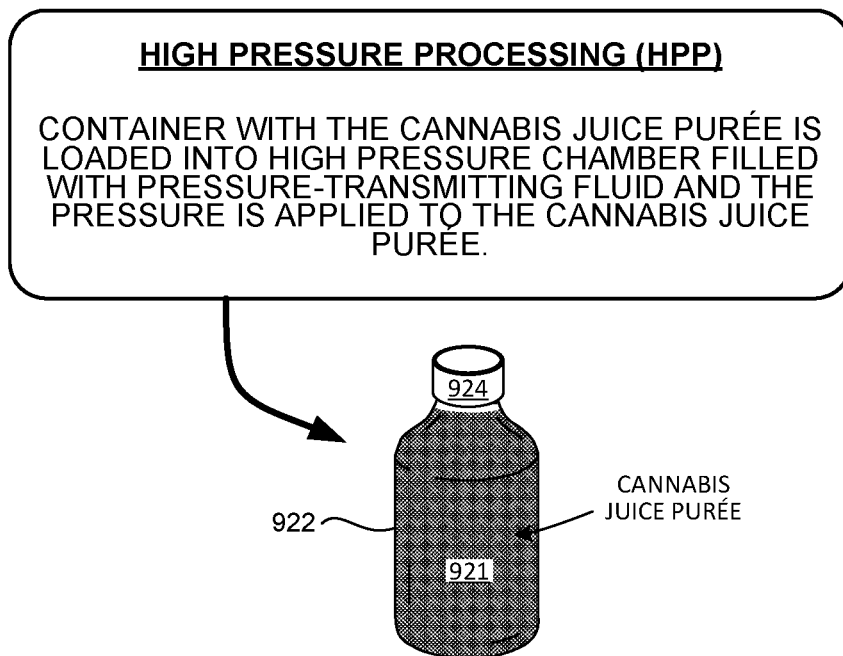

PACKAGING THE PLURALITY OF CONTAINERS
HAVING THE CANNABIS JUICE PURÉE

FIG. 57

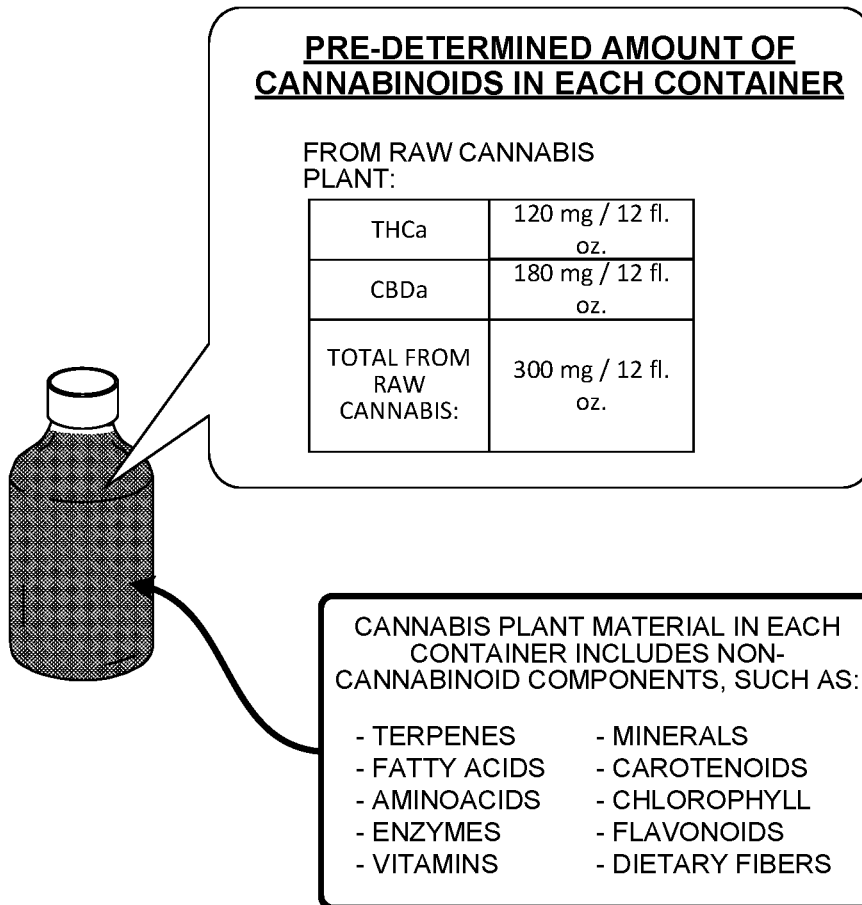

PACKAGED CANNABIS JUICE PURÉE
(WITHOUT DECARBOXYLATED CANNABINOID COMPONENTS)

FIG. 58A

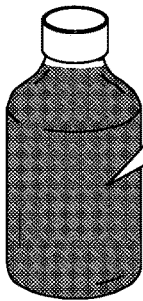

PRE-DETERMINED AMOUNT OF CANNABINOIDS IN EACH CONTAINER

FROM RAW CANNABIS PLANT:

THCa	120 mg / 12 fl. oz.
CBDa	180 mg / 12 fl. oz.
TOTAL FROM RAW CANNABIS:	300 mg / 12 fl. oz.

FROM NON-DECARBOXYLATED HIGH CONCENTRATE CANNABIS EXTRACT (KIEF):

THCa	2,400 mg / 12 fl. oz.
CBDa	3,600 mg / 12 fl. oz.
TOTAL FROM NON-DECARB. KIEF:	6,000 mg / 12 fl. oz.

PACKAGED CANNABIS JUICE PURÉE WITH ADDED NON-DECARBOXYLATED HIGH CONCENTRATE CANNABIS EXTRACT

(ALTERNATE EMBODIMENT)

FIG. 58B

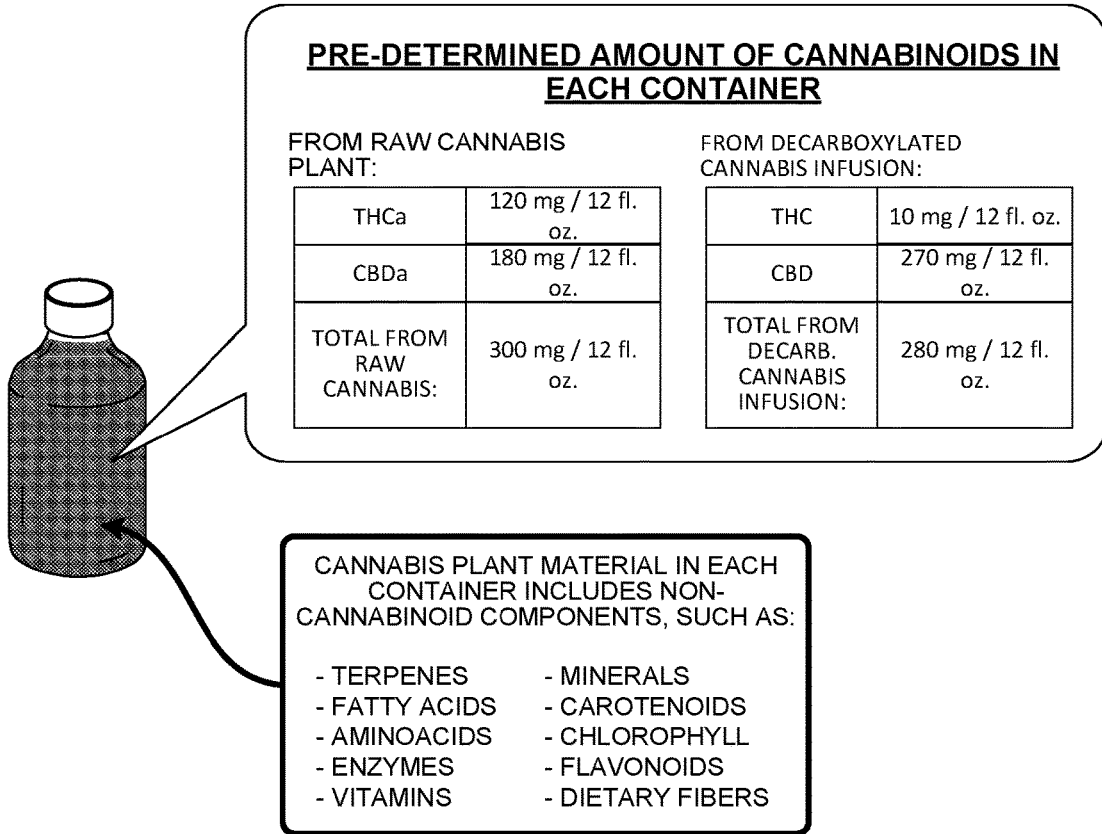

PACKAGED CANNABIS JUICE PURÉE WITH ADDED DECARBOXYLATED CANNABIS INFUSION

FIG. 59A

PRE-DETERMINED AMOUNT OF CANNABINOIDS IN EACH CONTAINER

FROM RAW CANNABIS PLANT:

THCa	120 mg / 12 fl. oz.
CBDa	180 mg / 12 fl. oz.
TOTAL FROM RAW CANNABIS:	300 mg / 3 fl. oz.

FROM DECARBOXYLATED CANNABIS INFUSION:

THC	10 mg / 12 fl. oz.
CBD	270 mg / 12 fl. oz.
TOTAL FROM DECARB. CANNABIS INFUSION:	280 mg / 12 fl. oz.

FROM NON-DECARBOXYLATED HIGH CONCENTRATE CANNABIS EXTRACT (KIEF):

THCa	2,400 mg / 12 fl. oz.
CBDa	3,600 mg / 12 fl. oz.
TOTAL FROM NON-DECARB. KIEF:	6,000 mg / 12 fl. oz.

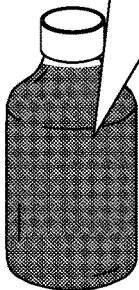

PACKAGED CANNABIS JUICE PURÉE WITH ADDED DECARBOXYLATED CANNABIS INFUSION AND NON-DECARBOXYLATED HIGH CONCENTRATE CANNABIS EXTRACT

(ALTERNATE EMBODIMENT)

FIG. 59B

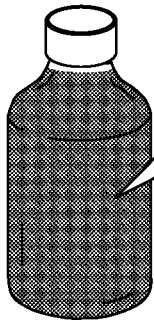

PRE-DETERMINED AMOUNT OF CANNABINOIDS IN EACH CONTAINER

FROM RAW CANNABIS PLANT:		FROM DECARBOXYLATED HIGH CONCENTRATE CANNABIS EXTRACT (KIEF):	
THCa	120 mg / 12 fl. oz.	THC	10 mg / 12 fl. oz.
CBDa	180 mg / 12 fl. oz.	CBD	300 mg / 12 fl. oz.
TOTAL FROM RAW CANNABIS:	300 mg / 12 fl. oz.	TOTAL FROM DECARB. KIEF:	310 mg / 12 fl. oz.

PACKAGED CANNABIS JUICE PURÉE WITH
ADDED DECARBOXYLATED HIGH
CONCENTRATE CANNABIS EXTRACT

(ALTERNATE EMBODIMENT)

FIG. 59C

PRE-DETERMINED AMOUNT OF CANNABINOIDS IN EACH CONTAINER

FROM RAW CANNABIS PLANT:

THCa	120 mg / 12 fl. oz.
CBDa	180 mg / 12 fl. oz.
TOTAL FROM RAW CANNABIS:	300 mg / 3 fl. oz.

FROM DECARBOXYLATED HIGH CONCENTRATE CANNABIS EXTRACT (KIEF):

THC	10 mg / 12 fl. oz.
CBD	300 mg / 12 fl. oz.
TOTAL FROM DECARB. KIEF:	310 mg / 12 fl. oz.

FROM NON-DECARBOXYLATED HIGH CONCENTRATE CANNABIS EXTRACT (KIEF):

THCa	2,400 mg / 12 fl. oz.
CBDa	3,600 mg / 12 fl. oz.
TOTAL FROM NON-DECARB. KIEF:	6,000 mg / 12 fl. oz.

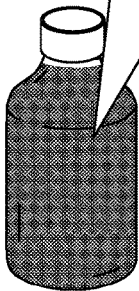

PACKAGED CANNABIS JUICE PURÉE WITH ADDED NON-DECARBOXYLATED AND DECARBOXYLATED HIGH CONCENTRATE CANNABIS EXTRACT

(ALTERNATE EMBODIMENT)

FIG. 59D

1000

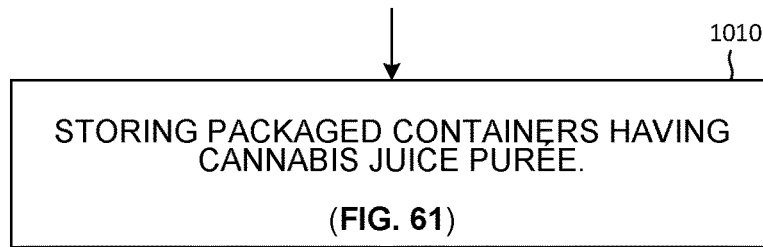
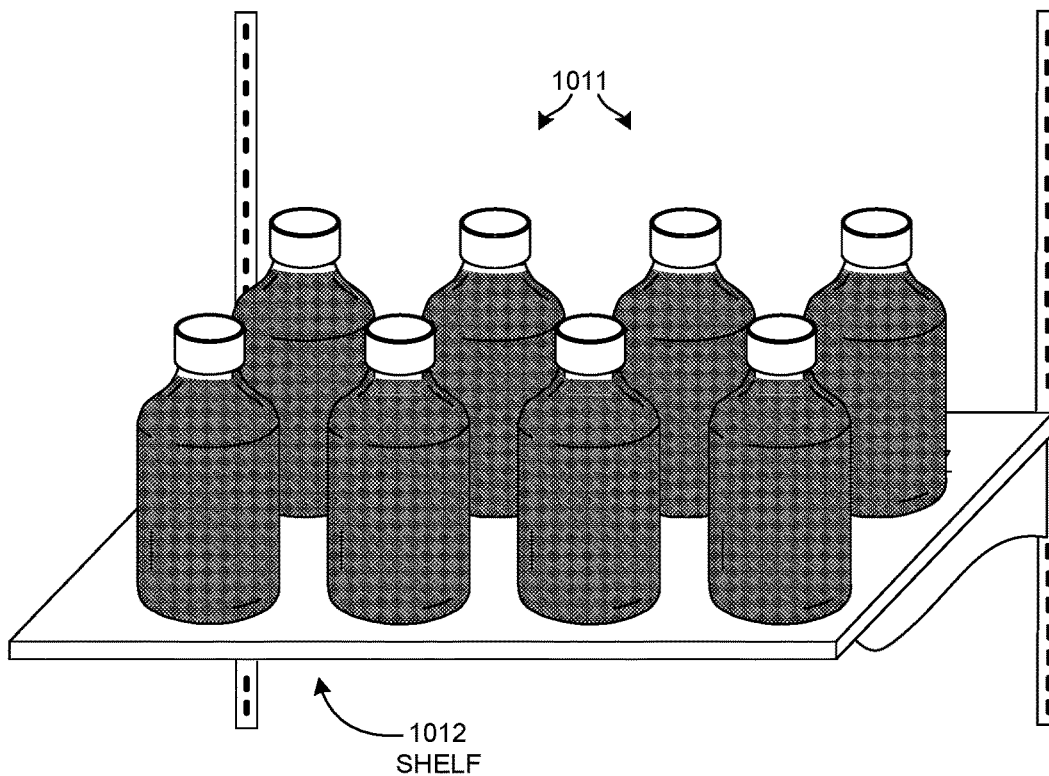

FIG. 60



STORING PACKAGED CONTAINERS WITH CANNABIS JUICE PURÉE

FIG. 61

1100 S	THC	CBD	CBG	CBN	CBC	THCV	THCA	CBDA
PAIN RELIEF	X	X		X	X			
APPETITE/ WEIGHT LOSS						X		
SUPPRESS BACTERIAL GROWTH		X	X					
REDUCE BLOOD SUGAR		X	X					
REDUCE SEIZURES		X				X		
REDUCE INFLAMMATION		X	X		X		X	X
AIDS SLEEP				X				
REDUCE RISK OF ARTERY BLOCKAGE			X					
INHIBIT TUMOR/ CANCER CELL GROWTH		X	X		X		X	X
TREATS PSORIASIS		X						
TRANQUILIZING/ MANAGE PSYCHOSIS		X						
SUPPRESS MUSCLE SPASM	X	X		X			X	
RELIEVE ANXIETY		X						
STIMULATE APPETITE	X							
PROMOTE BONE GROWTH		X	X		X	X		
REDUCE IMMUNE SYS. FUNCTION		X						
PROTECT NERVOUS SYS. DEGENERATION		X						

FIG. 62

1

**METHOD OF MAKING A PACKAGED
CANNABIS JUICE PURÉE FORMED
THROUGH HIGH PRESSURE PROCESSING**

CROSS REFERENCE TO RELATED
APPLICATIONS

This application is a continuation of, and claims the benefit under 35 U.S.C. § 120 from, nonprovisional U.S. patent application Ser. No. 15/213,334, entitled “Packaged Frozen Cubes Of *Cannabis* Juice Purée That Are Non-Psychoactive,” filed on Jul. 18, 2016, now U.S. Pat. No. 9,956,173. U.S. patent application Ser. No. 15/213,334 claims the benefit under 35 U.S.C. § 119 of U.S. provisional patent application Ser. No. 62/292,732, entitled “Dietary Supplement and Method of Production,” filed on Feb. 8, 2016. The subject matter of each of the foregoing documents is expressly incorporated herein by reference.

TECHNICAL FIELD

The present disclosure relates generally to methods for manufacturing and packaging dietary supplements, and more particularly to manufacturing and packaging cannabinoid products.

BACKGROUND INFORMATION

The *Cannabis* plant genus is known to produce over four hundred and eighty different chemical substances, and at least eighty of these chemical substances are classified as cannabinoids. Many cannabinoids have been found to have diverse medicinal uses which include analgesic, anti-inflammatory, anticancer, antibiotic, anti-anxiety, and anti-oxidant properties. There are now thousands of strains of the *Cannabis* plant that have evolved naturally or have been developed through hybridization. The different strains of *Cannabis* tend to contain different combinations of these cannabinoids in varying amounts.

Cannabinoids found in their natural state typically are in a non-decarboxylated form. Cannabinoids can be converted into a decarboxylated form by a process referred to as decarboxylation. Decarboxylation is a chemical reaction that removes the carboxyl group from a compound. In the case of cannabinoids, decarboxylation involves removing the carboxyl group from the cannabinoid compounds. One common technique for performing decarboxylation is by heating *Cannabis* material to 240° F. or higher for ten minutes to a few hours. Decarboxylation also occurs in *Cannabis* material if the material is allowed to be dry cured. These cannabinoids provide different medicinal benefits when they are in their ‘raw’ or non-decarboxylated form, compared to their properties after they are decarboxylated.

Two cannabinoids that show tremendous medicinal potential are tetrahydrocannabinol (THC) and cannabidiol (CBD). THC is the decarboxylated cannabinoid that is considered to be psychoactive. However, if the *Cannabis* material is never heated, ‘decarboxylated’, the cannabinoid will remain in its acid form, tetrahydrocannabinolic acid (THCa). THCa is not considered to be psychoactive. THCa also provides many medicinal benefits without causing psychoactive effects for the user. Most notably, THCa has many anti-inflammatory and cancer cell fighting properties while not being psychoactive. The cannabinoid CBD also is present in the acid form, cannabidiolic acid (CBDA), if the raw *Cannabis* material is not decarboxylated. But when

2

decarboxylated, the CBDA is converted to CBD. Both CBDA and CBD have a different set of medicinal properties.

Because decarboxylation occurs when the *Cannabis* material is dried or heated, it is challenging to find methods for consumers to have access to the ‘raw’ non-decarboxylated *Cannabis* material. Raw *Cannabis* leaves and flowers will begin to spoil or decarboxylate after a few days of being removed from the living plant. As a result, commercial distribution of raw non-decarboxylated *Cannabis* material has been commercially unfeasible. A solution that overcomes these challenges is desired.

SUMMARY

Methods of manufacturing, packaging, and storing *Cannabis* products are provided. In one embodiment, a plurality of frozen structures of *Cannabis* juice purée that comprises a pre-determined amount of non-decarboxylated cannabinoids is packaged and stored. In one example, the frozen structures of *Cannabis* juice purée are frozen cubes of *Cannabis* juice purée. The frozen cubes are also referred to as “frozen *Cannabis* juice purée cubes” or “cubes” due to their cubic shape. The frozen structures of *Cannabis* juice purée can be made to form shapes other than cubic shaped structures. The frozen *Cannabis* juice purée cubes are administered to individuals desiring the pre-determined amount of non-decarboxylated cannabinoids. A user can combine the frozen *Cannabis* juice purée cubes with other juices, fruits, vegetables, or supplements for consumption, for example, by adding a desired number of the cubes to a “smoothie” blend. The frozen *Cannabis* juice purée cubes do not include any decarboxylated cannabinoids. Decarboxylated cannabinoids are formed by heating raw *Cannabis* material thereby converting THCa to THC. THC may have psychoactive properties. Because the non-decarboxylated frozen *Cannabis* juice purée cubes do not include such decarboxylated cannabinoids, the frozen *Cannabis* juice purée cubes are generally non-psychoactive. Thus, a person can consume the frozen *Cannabis* juice purée cubes and obtain therapeutic benefits while still retaining his/her faculties to perform his/her ordinary daily routine.

The non-decarboxylated cannabinoid frozen *Cannabis* juice purée cubes are frozen thereby extending the shelf life of the cannabinoids within the cubes to at least six months. In conventional techniques used to collect and store non-decarboxylated cannabinoid material, the non-decarboxylated cannabinoid material lasts only between two and three days before spoiling. Due to the known shelf life limitations, packaging and distributing the non-decarboxylated cannabinoid material is not practical or commercially feasible. Unfortunately, individuals who require the non-decarboxylated cannabinoids for treating illnesses or health conditions do not have ready access to a consistent supply of non-decarboxylated cannabinoids, especially *Cannabis* material which contains the optimal levels and ratios of cannabinoids. The novel packaged frozen *Cannabis* juice purée cubes overcome this shortcoming by extending shelf life resulting in consistent and reliable access to cannabinoids in specific dosage amounts for individuals who require the cannabinoids to treat various medical conditions and to live more comfortably than they would be able to otherwise.

In a first step, raw *Cannabis* material is collected by trimming leaves or flowers of a *Cannabis* plant. The raw *Cannabis* material includes leaves, flowers, stems, trichomes, and other plant material from the *Cannabis* plant. The trimmed *Cannabis* material has a particular cannabinoid profile that has desired therapeutic qualities. The cannabi-

noid profile indicates types and proportions of cannabinoids present in the *Cannabis* material. Different types of *Cannabis* plants exhibit different cannabinoid profiles that are beneficial for certain types of medical conditions. The cannabinoid profile for a specific plant can be determined by a laboratory capable of performing a full spectrum cannabinoid profiling and analysis. Such laboratories often employ High Performance Liquid Chromatography (HPLC/UV) to conduct the analysis.

In one example, the *Cannabis* plant is selected such that the cannabinoid profile has tetrahydrocannabinolic acid (THCa) and cannabidiolic acid (CBDA) such that the THCa to CBDA ratio is 3 CBDA to 2 THCa. This means that for every 3.0 milligrams of CBDA in a unit of *Cannabis* material, there is approximately 2.0 milligrams of THCa. In another example, the *Cannabis* profile is taken from the group consisting of: 2 CBDA to 1 THCa, 1 CBDA to 1 THCa, 1 CBDA to 2 THCa, 1 CBDA to 3 THCa, 3 CBDA to 1 THCa, 0 CBDA to 1 THCa (no CBDA, only THCa), and 1 CBDA to 0 THCa (no THCa, only CBDA).

In a second step, a *Cannabis* juice purée is formed from the collected raw *Cannabis* material by blending the collected raw *Cannabis* material along with water and a thickening agent. The resulting *Cannabis* juice purée has a liquid composition and is also referred to as “a uniform purée” or “a liquefied *Cannabis* juice purée”. The water is filtered water, unfiltered water, ice formed from filtered water, or ice formed from unfiltered water. Alternatively, fruit juice or vegetable juice can be used in addition to or instead of water. The thickening agent aids in suspending the *Cannabis* material thereby aiding in a uniform distribution of cannabinoids throughout the *Cannabis* juice purée. A uniform distribution of cannabinoids throughout the *Cannabis* juice purée is desired to ensure that each cube has a consistent dose of cannabinoids. In one example, the variation in amount of cannabinoids in each cube is 10%. Without the thickening agent, the resulting mixture would have an upper layer with the water and a bottom layer with the *Cannabis* material rather than a uniform mixture. The thickening agent may be banana, avocado, psyllium husk, tapioca, or any food-grade thickening agent.

In accordance with one novel aspect, the *Cannabis* juice purée is formed without a juicing process. In a juicing process, a portion of the *Cannabis* plant material is separated from the juice of the *Cannabis* plant. At least part of the separated *Cannabis* plant material is treated as waste and is disposed. To form the *Cannabis* juice purée, however, all of the *Cannabis* plant material is converted into the *Cannabis* juice purée. The resulting *Cannabis* juice purée includes all of the *Cannabis* plant material placed in the blender and all of the extracted *Cannabis* juice that is extracted in the blending process. No waste product is generated in forming the *Cannabis* juice purée. Accordingly, the *Cannabis* juice purée has all of the *Cannabis* plant material and is rich in dietary fibers and non-cannabinoid components that include terpenes, fatty acids, aminoacids, enzymes, vitamins, minerals, carotenoids, chlorophyll, and flavonoids.

In a third step, the *Cannabis* juice purée is deposited into molds of a tray. The tray has a plurality of molds each having a substantially identical size, shape, and volume. Depositing the *Cannabis* juice purée into similar molds results in each cube having a substantially similar amount of cannabinoids. An individual tends to prefer reliable and consistent doses, thus similarly sized cubes with substantially the same cannabinoid profiles are desired. In addition, by using a tray

with the same size of molds, the cubes can be effectively mass produced thereby reducing the overall cost of cubes to the consumer.

In a fourth step, the tray of molds having the *Cannabis* juice purée is frozen to form the frozen *Cannabis* juice purée cubes. In one example, the tray having the *Cannabis* juice purée is placed in a freezer having a temperature less than 5.0° F., or alternatively less than 0.0° F. Freezing the *Cannabis* juice purée results in a shelf-life of more than six months if the cubes are properly stored in a freezer. The *Cannabis* juice purée used to form the cubes does not contain any dairy product, milk-based product, or cream type of product, such as coconut milk. The frozen *Cannabis* juice purée cubes are in a solid state and are frozen, solid structures that maintain their structure when placed next to each other. The frozen *Cannabis* juice purée cubes do not have a soft, malleable consistency such as a sorbet-type consistency or ice cream-type consistency.

In a fifth step, the frozen *Cannabis* juice purée cubes having the non-decarboxylated cannabinoids are packaged into a package. The frozen *Cannabis* juice purée cubes are packaged in a vacuum sealed package, a bag, or a container having a detachable lid. A label identifying the contents can be placed onto the outside of the package. No additional packaging material is placed inside the package. The cubes are loosely packed so that they do not touch, or are tightly packed so that each cube contacts at least one other cube. Because the frozen *Cannabis* juice purée cubes are frozen prior to packaging and the purée recipe freezes to a hardness similar to ice (not a soft malleable texture like ice cream or sorbet), the frozen *Cannabis* juice purée cubes can contact each other inside the package without damaging their integrity or dosage amount per cube. Each cube has at least one surface that directly contacts a surface of the package. Each cube is adjacent to at least two other cubes. The cubes within the package consume over 95% of the total volume of package. In addition, the package of cubes has at least two flat surfaces thereby providing optimal storing and transporting characteristics. In another example, the cubes are stacked so that not all of the cubes contact the package.

In accordance with another novel aspect, a plurality of packages having frozen *Cannabis* juice purée cubes with only non-decarboxylated cannabinoids is stored. The packages are stored in a freezer by stacking each package above another package. Each package has at least two flat surfaces due to the uniform size and shape of each cube. Accordingly, the packages stack compactly in the freezer. In one example, a manufacturing entity manufactures and provides the packaged frozen *Cannabis* juice purée cubes with only non-decarboxylated cannabinoids to a dispensary entity. The dispensary entity handles storing the packaged cubes until the packaged cubes are provided to end consumers.

In a second embodiment, the packaged frozen *Cannabis* juice purée cubes comprise non-decarboxylated cannabinoids and decarboxylated cannabinoids. The amount of decarboxylated cannabinoids in each frozen structure is at least 5 mg. A structure with less than 5 mg is not considered to be a therapeutic dose of decarboxylated cannabinoids because consuming less than 5 mg decarboxylated cannabinoids has negligible, if any, effects on the user. The amount of decarboxylated cannabinoids may include one type of decarboxylated cannabinoid (such as CBD) or more than one type of decarboxylated cannabinoid (such as CBD and THC).

The packaged frozen *Cannabis* juice purée cubes with both non-decarboxylated cannabinoids and decarboxylated cannabinoids provides consumers with a full spectrum of

5

THCa, THC, CBDa, CBD, and all of the other *Cannabis* compounds in both the non-decarboxylated and decarboxylated forms, in one easy-to-consume frozen purée cube. The frozen *Cannabis* juice purée cubes include at least one cannabinoid taken from the group consisting of: cannabigerolic acid (CBGa), cannabigerovarin acid (CBGVA), tetrahydrocannabinolic acid (THCA), tetrahydrocannabivarin carboxylic acid (THCVA), cannadidiolic acid (CBDA), cannabidivarin acid (CBDVA), cannabichrome carboxylic acid (CBCA), cannabichrome varinic acid (CBCVA), tetrahydrocannabinol (THC), tetrahydrocannabidivarin (THCV), tetrahydrocannabivarin acid (THVA), cannabidiol (CBD), cannabidivarin (CBDV), cannabichromene (CBC), cannabichromevarin (CBCV), cannabigerol (CBG), cannabigerovarin (CBGV), cannabinerolic acid (CBNA), cannabigerovarinic acid (CBNVA), cannabiniol (CBN), cannabicyclol (CBL), and cannabicyclol acid (CBLA).

In a first step, two separate portions of raw *Cannabis* material are collected. The first portion of raw *Cannabis* material may come from a strain of *Cannabis* with a unique cannabinoid ratio (for example, 3 CBDa to 2 THCa). This first portion will remain in its non-decarboxylated state. Other cannabinoid ratios in the first portion include: 2 CBDa to 1 THCa, 1 CBDa to 1 THCa, 1 CBDa to 2 THCa, 1 CBDa to 3 THCa, 3 CBDa to 1 THCa, 0 CBDa to 1 THCa (no CBDa, only THCa), and 1 CBDa to 0 THCa (no THCa, only CBDa). The second portion of *Cannabis* is collected from a different strain of *Cannabis* plant with a different unique cannabinoid profile (for example, 30 CBDa to 1 THCa). This second portion will later be decarboxylated. When this second portion is decarboxylated, the ratio of the decarboxylated cannabinoids becomes 30 CBD to 1 THC. Other cannabinoid ratios in the decarboxylated second portion include: 20 CBD to 1 THC, 10 CBD to 1 THC, or 5 CBD to 1 THC.

In an alternative step, the first portion (non-decarboxylated portion) of raw *Cannabis* material and the second portion (to be decarboxylated) of raw *Cannabis* material are collected from the same strain of *Cannabis* plant with the exact same cannabinoid profile. In one example, the first portion is 3 CBDa to 2 THCa, and the second portion is also 3 CBDa to 2 THCa. Once decarboxylated, the second portion will convert to a ratio of 3 CBD to 2 THC. Other combinations of cannabinoid materials having different cannabinoid profiles can be selected depending upon the desired therapeutic effects or medical conditions being targeted. An artisan of ordinary skill would appreciate the vast number of combinations of types and amounts of cannabinoids that can be used to create the cubes.

In a second step, a non-decarboxylated *Cannabis* juice purée is formed from the first portion of raw *Cannabis* material and a decarboxylated *Cannabis* infusion is formed from the second portion of raw *Cannabis* material. The non-decarboxylated *Cannabis* juice purée is formed by blending the first portion of collected raw *Cannabis* material along with water and a thickening agent. The decarboxylated *Cannabis* infusion is formed by heating the second portion of collected raw *Cannabis* material. Decarboxylating *Cannabis* material can be achieved through heating the *Cannabis* material at a temperature of 240° F. for 30 minutes or longer in a mixture of fatty oil. Decarboxylating *Cannabis* material can also be achieved through heating the *Cannabis* material in an oven without any oil or substance.

In a third step, the non-decarboxylated *Cannabis* juice purée and the decarboxylated *Cannabis* infusion are deposited into molds of a tray such that each mold has non-

6

decarboxylated and decarboxylated cannabinoids. The non-decarboxylated *Cannabis* juice purée is deposited into each mold to fill approximately half of the mold. Next, the decarboxylated *Cannabis* infusion is deposited at a center location on the top surface of the half-filled mold. Next, the non-decarboxylated *Cannabis* juice purée is deposited above the decarboxylated *Cannabis* infusion to fill the rest of each mold.

Alternatively, the decarboxylated *Cannabis* infusion is deposited into the non-decarboxylated *Cannabis* juice purée during the blending process. By adding the decarboxylated *Cannabis* infusion during the blending process, the decarboxylated cannabinoids are uniformly distributed throughout the *Cannabis* juice purée resulting in a uniform distribution of cannabinoids in each cube after the freezing process.

In a fourth step, the tray of molds having the *Cannabis* juice purée is frozen to form the frozen *Cannabis* juice purée cubes having non-decarboxylated and decarboxylated cannabinoids. The *Cannabis* juice purée used to form the cubes does not contain any dairy product, milk-based product, or cream type of product, such as coconut milk. The tray of molds having the *Cannabis* juice purée is placed in a freezer having a temperature less than 5.0° F., or alternatively less than 0.0° F. Freezing the *Cannabis* juice purée results in an extended shelf-life of at least six months if the frozen *Cannabis* juice purée cubes are properly stored in a freezer. The frozen *Cannabis* juice purée cubes are in a solid state and are frozen, solid structures that maintain their structure when placed next to each other. The frozen *Cannabis* juice purée cubes do not have a soft, malleable consistency such as a sorbet-type consistency or ice cream-type consistency.

In a fifth step, the frozen *Cannabis* juice purée cubes having the non-decarboxylated and decarboxylated cannabinoids are packaged into a package. The frozen *Cannabis* juice purée cubes are packaged in a vacuum sealed package, a bag, or a container having a detachable lid. A label identifying the contents can be placed onto the outside of the package. No additional packaging material is placed inside the package. The cubes are loosely packed so that not all of the cubes contact each other, or are tightly packed so that each cube contacts at least one other cube. Because the frozen *Cannabis* juice purée cubes are frozen prior to packaging and the purée recipe freezes to a hardness similar to ice (not a soft malleable texture like ice cream or sorbet), the frozen *Cannabis* juice purée cubes can contact each other inside the package without damaging their integrity or dosage amount per cube. Each cube has at least one surface that directly contacts a surface of the package. Each cube is adjacent to at least two other cubes. The cubes within the package consume over 95% of the total volume of package. In addition, the package of cubes has at least two flat surfaces thereby providing optimal storing and transporting characteristics. In another example, the cubes are stacked so that not all of the cubes contact the package.

In accordance with another novel aspect, a plurality of packages having frozen *Cannabis* juice purée cubes is stored. The packages are stored in a freezer by stacking each package above another package. Each package has at least two flat surfaces due to the uniform size and shape of each cube. Accordingly, the packages stack compactly in the freezer. In one example, a manufacturing entity manufactures and provides the packaged frozen *Cannabis* juice purée cubes to a dispensary entity. The dispensary entity handles storing the packaged cubes until the packaged cubes are provided to end consumers.

In a third embodiment, a method of manufacturing and packaging frozen ice pops of *Cannabis* juice purée is provided. The resulting packaged frozen ice pops of *Cannabis* juice purée are also referred to as a “frozen *Cannabis* to go pack”, “frozen *Cannabis* on the go pop”, “frozen *Cannabis* icicle”, or “frozen *Cannabis* popsicle”. In one specific embodiment, the packaged frozen ice pop of *Cannabis* juice purée has an amount of non-decarboxylated cannabinoids and is non-psychoactive. In another specific embodiment, the packaged frozen ice pop of *Cannabis* juice purée has an amount of non-decarboxylated cannabinoids and an amount of decarboxylated cannabinoids.

In a first step, a *Cannabis* juice purée is formed. To form a packaged frozen ice pop of *Cannabis* juice purée that is non-psychoactive, raw *Cannabis* material having an amount of non-decarboxylated cannabinoids is collected but never heated. The amount of non-decarboxylated cannabinoids is blended together with a thickening agent and a sweetening agent such as honey, *stevia*, fruit juice, sugar, or corn syrup. The sweetening agent is optional and is not included in some embodiments. Flavoring agents are included in other embodiments, such as fruit flavor or spice (apple, cherry, mint, tart, etc.). Fruit juice, fruit, or vegetable material may also be added, such as blueberries, blueberry juice, carrots, or carrot juice. Non-decarboxylated high concentrate *Cannabis* extract may also be added to the *Cannabis* juice purée prior to freezing to increase the amount of non-decarboxylated cannabinoids in each ice pop.

To form a packaged frozen ice pop of *Cannabis* juice purée that has decarboxylated cannabinoids, a portion of the collected raw *Cannabis* material is heated to obtain an amount of decarboxylated cannabinoids. The amount of decarboxylated cannabinoids are added to the *Cannabis* juice purée prior to freezing. Non-decarboxylated high concentrate *Cannabis* extract, decarboxylated high concentrate *Cannabis* extract, decarboxylated *Cannabis* infusion, or heated *Cannabis* material may also be added to the *Cannabis* juice purée prior to freezing to increase the amount of non-decarboxylated and decarboxylated cannabinoids in each ice pop.

In a second step, the *Cannabis* juice purée is deposited into a container. In one example, the container is a tube shaped container made of a flexible material. The container is a tube shaped container formed from a thermoplastic polymer such as polypropylene plastic resin. In one example, the tube shaped container has a resealable end. In another example, the tube shaped container is not resealable and a user must permanently tear a portion of the container to access the frozen ice pop of *Cannabis* juice purée.

In a third step, the container having the *Cannabis* juice purée is frozen to form a packaged frozen ice pop of *Cannabis* juice purée. The container having the *Cannabis* juice purée is placed in a freezer so that the *Cannabis* juice purée in the container (along with any added *Cannabis* infusion or high concentrate *Cannabis* extract) can freeze. The temperature within the freezer is typically between 0.0° F. and 5.0° F., but may be less than 0.0° F. The resulting frozen ice pop of *Cannabis* juice purée assumes the shape of the container. In one example, packaged frozen ice pop of *Cannabis* juice purée is a cylindrical tube shaped structure.

In a fourth embodiment, a method of manufacturing and packaging a *Cannabis* juice purée is provided. In one specific embodiment, the packaged *Cannabis* juice purée has an amount of non-decarboxylated cannabinoids and is non-psychoactive. In another specific embodiment, the

packaged *Cannabis* juice purée has an amount of non-decarboxylated cannabinoids and an amount of decarboxylated cannabinoids.

In a first step, a *Cannabis* juice purée is formed. To form a packaged *Cannabis* juice purée that is non-psychoactive, raw *Cannabis* material having an amount of non-decarboxylated cannabinoids is collected but never heated. The raw *Cannabis* material is blended together with a thickening agent and a sweetening agent such as honey, *stevia*, fruit juice, sugar, or corn syrup. Non-decarboxylated high concentrate *Cannabis* extract may also be added to the *Cannabis* juice purée to increase the amount of non-decarboxylated cannabinoids in each container.

To form a packaged *Cannabis* juice purée that comprises decarboxylated cannabinoids, a portion of the collected raw *Cannabis* material is heated to obtain an amount of decarboxylated cannabinoids. The amount of decarboxylated cannabinoids are added to the *Cannabis* juice purée. Non-decarboxylated high concentrate *Cannabis* extract, decarboxylated high concentrate *Cannabis* extract, decarboxylated *Cannabis* infusion, or heated *Cannabis* material may also be added to the *Cannabis* juice purée to increase the amount of non-decarboxylated and decarboxylated cannabinoids in each container.

In a second step, *Cannabis* juice purée is deposited into a container. The container is a cylindrical shaped structure having a lid. The container is formed from a glass material, a plastic material, or a paper-based material. The *Cannabis* juice purée is deposited into the container through an opening.

In a third step, the container having the *Cannabis* juice purée is packaged. In one example, the *Cannabis* juice purée is processed using high pressure processing (HPP). In HPP, the *Cannabis* juice purée is loaded into a high pressure chamber filled with pressure transmitting fluid, such as water. The pressure is applied to the *Cannabis* juice purée. A lid is used to seal the opening of the container.

HPP allows the mixture to be pasteurized without applying heat. HPP extends shelf life of the *Cannabis* juice purée to several weeks to months without applying heat that could undesirably decarboxylate the cannabinoids present in the *Cannabis* juice purée. Thus, shelf life is preserved while providing a liquid beverage form of *Cannabis* juice purée.

Forming the *Cannabis* juice purée and freezing *Cannabis* juice purée into serving size cubes or ice pops is a significant improvement over the conventional art. Significant research and testing was involved to ascertain the optimal process and technique. For example, this development process involves selecting the most effective strains of *Cannabis* having optimal cannabinoid profiles, determining the effective proportions and amounts of materials to combine to ensure a consistent dosage amount of cannabinoids per serving, and selecting the optimal technique for creating the *Cannabis* juice purée, selecting the size and shape of the cube, and determining the most efficient and convenient packaging for the end consumer.

In particular, the invention yields significant advantages over prior attempts of forming mixture via juicing machines or wheat grass juicers. For example, prior attempts using conventional juicing machines or wheat grass juicers resulted in very little juice and substantial leaf pulp. The conventional juicing machines or wheat grass juicers were not powerful enough to blend the raw *Cannabis* leaves into the smooth purée consistency that is desired for the *Cannabis* juice purée. Such conventional blenders generated leaf pulp that was too thick and abrasive for consumption. However, a high powered juice blender (such as a Vitamix

blender) with water and banana achieved the most desirable *Cannabis* juice purée having the proper texture and purée composition. In addition, without the banana, the *Cannabis* juice purée separated into raw *Cannabis* material on bottom and water on top.

In addition, conventional techniques did not have the proper size and shape to achieve a dosage of over 20 milligrams of cannabinoids per cube. The recipe, cube size, and technique for creating the cubes resulted from substantial laboratory testing to achieve the desired results. Consequently, one of ordinary skill will appreciate that the various novel embodiments allow the mass market to have reliable and cost effective access to non-decarboxylated *Cannabis* material which contains consistent levels of THCa, CBDa, and all of the other non-decarboxylated cannabinoids present in raw *Cannabis* material.

One technique for making “marijuana juice” ice cubes is known. To make “marijuana juice” ice cubes, a juice extractor is used to extract “marijuana juice” from leaves of *Cannabis* plants. The extracted “marijuana juice” is used to make ice cubes. Several shortcomings exist with this technique. First, using a juice extractor removes many non-cannabinoid components present in the *Cannabis* plant material (stems, leaves, flowers, etc.) that offer significant nutritional value. Second, juice extractors tend to emit heat during use, especially extended use, and this emitted heat may undesirably decarboxylate the cannabinoids present in the leaves. Such overheating also renders juice extractors inefficient for commercial production. Third, the “marijuana juice” ice cubes do not have consistent doses of cannabinoids in each ice cube. One ice cube may have more cannabinoids than another ice cube. Consistent dosage is essential for patients who require specific amounts of cannabinoids to treat illness and who also require consistent doses to monitor progress and adjust cannabinoid intake as needed. Additionally, many patients require specific ratios of one cannabinoid to another cannabinoid for achieving desired medical benefits. The “marijuana juice” ice cubes do not yield consistent doses of cannabinoids or specific ratios of cannabinoids. Fourth, the “marijuana juice” ice cubes are not packaged and are meant to be removed from an ice cube tray to be consumed by the user. Typical patients require consistent access to cannabinoids. Packaging the “marijuana juice” ice cubes is difficult because the ice cubes can meld together causing additional inconsistencies in dosage amounts. No effective way to package, store, and commercially distribute the “marijuana juice” ice cubes is known. Consequently, the “marijuana juice” ice cubes are not a commercially viable technique for administering cannabinoids along with *Cannabis* plant material rich in nutrients that are stored and packaged for mass distribution. Lastly, no technique is known for adding high concentrate *Cannabis* extract or *Cannabis* infusion to the “marijuana juice” ice cubes. Many patients require high amounts of specific non-decarboxylated or decarboxylated cannabinoids which is not feasible to achieve by consuming the “marijuana juice” ice cubes. The novel packaged frozen *Cannabis* juice purée cubes solve all of these shortcomings.

The foregoing is a summary and thus contains, by necessity, simplifications, generalizations and omissions of detail; consequently it is appreciated that the summary is illustrative only. Still other methods, and structures and details are set forth in the detailed description below. This summary does not purport to define the invention. The invention is defined by the claims.

BRIEF DESCRIPTION OF THE DRAWINGS

The accompanying drawings, where like numerals indicate like components, illustrate embodiments of the invention.

FIG. 1 is a flowchart of a method 100 in accordance with one embodiment.

FIG. 2 is a perspective diagram showing how raw *Cannabis* material 112 is collected by trimming leaves 113 from the *Cannabis* plant 111.

FIG. 3 is a perspective diagram showing how the *Cannabis* juice purée is formed.

FIG. 4 is a perspective diagram showing how the *Cannabis* juice purée 131 is deposited into molds 132.

FIG. 5 is a perspective diagram showing how the tray 133 is placed in a freezer 141.

FIG. 6 is a perspective diagram showing how the frozen *Cannabis* juice purée cubes 151 are removed from tray 133 and placed on vacuum sealed bag 152.

FIG. 7 is a perspective diagram of a package 154 with the frozen *Cannabis* juice purée cubes 151.

FIG. 8 is a side view of the package 154 with the cubes 151.

FIG. 9 is top view of the package 154 with the frozen *Cannabis* juice purée cubes 151.

FIG. 10A is a perspective diagram of frozen *Cannabis* juice purée cubes 151 having an amount of non-decarboxylated cannabinoids.

FIG. 10B is a perspective diagram of another embodiment of the frozen structures where an amount of non-decarboxylated high concentrate *Cannabis* extract has been added to the *Cannabis* juice purée prior to freezing.

FIG. 10C is a diagram of a female *Cannabis* plant with flowers 165 having trichomes 164.

FIG. 10D is a table 170 showing various non-cannabinoid components and cannabinoid components that are obtainable from *Cannabis* plant material.

FIG. 11 is a table 163 showing two general types of non-decarboxylated cannabinoids.

FIG. 12 is a flowchart of a method 200 in accordance with a second embodiment.

FIG. 13 is a perspective diagram showing how raw *Cannabis* material 211 is collected from a first *Cannabis* plant 212 and a second *Cannabis* plant 213.

FIG. 14 is a perspective diagram showing how the non-decarboxylated *Cannabis* juice purée is formed.

FIG. 15 is a perspective diagram showing how to make a decarboxylated *Cannabis* infusion.

FIG. 16 is a perspective diagram showing how the non-decarboxylated *Cannabis* juice purée 231 and the decarboxylated *Cannabis* infusion 234 are deposited into molds 232.

FIG. 17 is a perspective diagram showing how the tray 233 is placed in a freezer 242.

FIG. 18 is a perspective diagram showing how the frozen *Cannabis* juice purée cubes 251 are removed from the tray 233 and placed on vacuum sealed bag 252.

FIG. 19 is a perspective diagram of a package 254 with the frozen *Cannabis* juice purée cubes 251.

FIG. 20 is a side view of the package 254 with the frozen *Cannabis* juice purée cubes 251.

FIG. 21 is top view of the package 254 with the frozen *Cannabis* juice purée cubes 251.

FIG. 22A is a perspective diagram of frozen *Cannabis* juice purée cubes 251 having an amount of non-decarboxylated cannabinoids and an amount of decarboxylated cannabinoids.

FIG. 22B is a perspective diagram of another embodiment of frozen structures of *Cannabis* juice purée with added decarboxylated *Cannabis* infusion and non-decarboxylated high concentrate *Cannabis* extract.

FIG. 22C is a perspective diagram of another embodiment of frozen structures of *Cannabis* juice purée with added decarboxylated high concentrate *Cannabis* extract.

FIG. 22D is a perspective diagram of another embodiment of frozen structures of *Cannabis* juice purée with added decarboxylated high concentrate *Cannabis* extract and non-decarboxylated high concentrate *Cannabis* extract.

FIG. 23 is a table 263 showing two general types of decarboxylated cannabinoids, THC and CBD, along with their chemical names and structural formulas.

FIG. 24 is a flowchart of a method 300 in accordance with another novel aspect.

FIG. 25 is a perspective diagram showing how a plurality of packages 311 is stored in a freezer 312.

FIG. 26 is a perspective diagram of a tray 400 having a plurality of molds 401.

FIG. 27 is a top view of the tray 400 having a plurality of molds 401.

FIG. 28 is a top view of a tray 403 having a plurality of cylindrical shaped molds.

FIG. 29 is a top view of a tray 404 having a plurality of rectangular shaped molds.

FIG. 30 is a top view of a tray 405 having a plurality of hexagonal shaped molds.

FIG. 31 is a top view of a tray 406 having a plurality of triangular shaped molds.

FIG. 32 is a top view of a tray 407 having a plurality of star shaped molds.

FIG. 33 is a top view of a tray 408 having a plurality of trapezoidal shaped molds.

FIG. 34 is a top view of a tray 409 having a plurality of concave shaped molds.

FIG. 35 is a top view of a tray 410 having a plurality of parallelogram shaped molds.

FIG. 36 is a top view of a tray 411 having a plurality of leaf shaped molds.

FIG. 37 is a diagram of a conventional coconut milk based *Cannabis* ice cream 420.

FIG. 38 is a diagram showing how the container 421 is placed onto a container holder 423.

FIG. 39 is a diagram showing how the container holder 423 having six containers is placed into a package 425.

FIG. 40 is a diagram of the package 425 containing the container holder 423 having the six containers with coconut milk based *Cannabis* ice creams.

FIG. 41 is a table 500 showing the advantages of novel package 154 (shown in FIG. 7) and novel package 254 (shown in FIG. 19) over the conventional package 425 shown in FIG. 40.

FIG. 42 is a flowchart of a method 600 in accordance with a third embodiment.

FIG. 43 is a perspective diagram showing how the *Cannabis* juice purée 621 is deposited into container 622.

FIG. 44 is a perspective diagram showing how the container 622 having the *Cannabis* juice purée 621 is placed in a freezer 631.

FIG. 45A is a perspective diagram of the packaged frozen ice pop of *Cannabis* juice purée 632 with only non-decarboxylated cannabinoids.

FIG. 45B is a perspective diagram of another embodiment of a packaged frozen ice pop of *Cannabis* juice purée with added non-decarboxylated high concentrate *Cannabis* extract.

FIG. 46A is a perspective diagram of a packaged frozen ice pop of *Cannabis* juice purée 634 with added decarboxylated cannabinoids.

FIG. 46B is a perspective diagram of another embodiment of a packaged frozen ice pop of *Cannabis* juice purée with added decarboxylated *Cannabis* infusion and non-decarboxylated high concentrate *Cannabis* extract.

FIG. 46C is a perspective diagram of another embodiment of a packaged frozen ice pop of *Cannabis* juice purée with added decarboxylated high concentrate *Cannabis* extract.

FIG. 46D is a perspective diagram of another embodiment of a packaged frozen ice pop of *Cannabis* juice purée with added decarboxylated high concentrate *Cannabis* extract and non-decarboxylated high concentrate *Cannabis* extract.

FIG. 47 is a diagram of a user 635 consuming the packaged frozen ice pop of *Cannabis* juice purée 632/634.

FIG. 48 is a diagram of a side view of the packaged frozen ice pop of *Cannabis* juice purée 632/634.

FIG. 49 is a diagram of a top view of the packaged frozen ice pop of *Cannabis* juice purée 632/634.

FIG. 50 is a diagram of a side view of another embodiment of a packaged frozen ice pop of *Cannabis* juice purée 650 having a container 651 that is not resealable.

FIG. 51 is a flowchart of a method 700 to package a plurality of packaged frozen ice pops of *Cannabis* juice purées.

FIG. 52 is a perspective diagram showing how a plurality of packaged frozen ice pops of *Cannabis* juice purées 711 is placed inside a package 712.

FIG. 53 is a flowchart of a method 800 to store packages comprising a plurality of packaged frozen ice pops of *Cannabis* juice purée.

FIG. 54 is a perspective diagram showing how a plurality of packages 811 are stored in a freezer 812.

FIG. 55 is a flowchart of a method 900 in accordance with fourth embodiment.

FIG. 56 is a perspective diagram showing how the *Cannabis* juice purée 921 is deposited into a container 922.

FIG. 57 is a perspective diagram of performing high pressure processing (HPP) during the packaging of the *Cannabis* juice purée 921.

FIG. 58A is a perspective diagram of the packaged *Cannabis* juice purée with only non-decarboxylated cannabinoids.

FIG. 58B is a perspective diagram of another embodiment of a packaged *Cannabis* juice purée with added non-decarboxylated high concentrate *Cannabis* extract.

FIG. 59A is a perspective diagram of a packaged *Cannabis* juice purée having decarboxylated cannabinoids.

FIG. 59B is a perspective diagram of another embodiment of a packaged *Cannabis* juice purée with added decarboxylated *Cannabis* infusion and non-decarboxylated high concentrate *Cannabis* extract.

FIG. 59C is a perspective diagram of another embodiment of a packaged *Cannabis* juice purée with added decarboxylated high concentrate *Cannabis* extract.

FIG. 59D is a perspective diagram of another embodiment of a packaged *Cannabis* juice purée with added decarboxylated high concentrate *Cannabis* extract and non-decarboxylated high concentrate *Cannabis* extract.

FIG. 60 is a flowchart of a method 1000 to store packaged containers having a *Cannabis* juice purée.

FIG. 61 is a perspective diagram of containers 1011 each having a *Cannabis* juice purée that are stored on a shelf 1012.

FIG. 62 is a table 1100 that shows the therapeutic benefits of various types of cannabinoids.

Reference will now be made in detail to some embodiments of the invention, examples of which are illustrated in the accompanying drawings.

DETAILED DESCRIPTION

FIG. 1 is a flowchart of a method **100** in accordance with one embodiment. The method **100** is a method of manufacturing and packaging a plurality of frozen structures of *Cannabis* juice purée that comprises a pre-determined amount of non-decarboxylated cannabinoids.

In a first step (step **110**), raw *Cannabis* material is collected. The raw *Cannabis* material includes an amount of non-decarboxylated cannabinoids. The term “non-decarboxylated” means that the cannabinoids are in their acid form. Non-decarboxylated cannabinoids are not considered to be psychoactive. For example, in FIG. 2, raw *Cannabis* material **112** is collected by trimming leaves **113** from the *Cannabis* plant **111**. The cannabinoid profile indicates types and proportions of cannabinoids present in the *Cannabis* material. An example of a cannabinoid profile is shown in FIG. 10A where the cannabinoid contents of the cubes is shown.

The *Cannabis* plant **111** is cultivated to have a specific cannabinoid profile. Different cannabinoid profiles yield different therapeutic benefits appreciated by an artisan of ordinary skill. In this example, the *Cannabis* plant **111** has a cannabinoid profile that includes tetrahydrocannabinolic acid (THCa) and cannabidiolic acid (CBDA). The *Cannabis* plant **111** is selected having a cannabinoid profile where the amount of THCa and CBDA is present in a desired ratio. In the example of FIG. 2, the ratio is 3 CBDA to 2 THCa. In other examples, the ratio is taken from the group consisting of: 2 CBDA to 1 THCa, 1 CBDA to 1 THCa, 1 CBDA to 2 THCa, 1 CBDA to 3 THCa, 3 CBDA to 1 THCa, 0 CBDA to 1 THCa (no CBDA, only THCa), and 1 CBDA to 0 THCa (no THCa, only CBDA).

For additional information on cannabinoid profiles, their therapeutic benefits, and techniques for delivering the cannabinoids to a user, see: (1) U.S. Pat. No. 9,220,294, entitled “Methods and Devices Using *Cannabis* Vapors”, filed Apr. 29, 2014 by McCullough; (2) U.S. Pat. No. 9,205,063, entitled “Cannabinoid-containing Plant Extracts As Neuro-protective Agents”, filed Jan. 24, 2014 by Guy et al.; (3) U.S. Pat. No. 9,186,386, entitled “Pharmaceutical Composition And Method Of Manufacturing”, filed May 28, 2015 by Speier; (4) U.S. Pat. No. 9,155,767, entitled “Essential Element Management”, filed Oct. 18, 2012 by Hospodor et al.; (5) U.S. Pat. No. 9,149,499, entitled “*Cannabis* Based Therapeutic And Method Of Use”, filed May 19, 2014 by Robinson; (6) U.S. Pat. No. 9,095,563, entitled “Topical Treatments Incorporating *Cannabis* Sp. Derived Botanical Drug Product”, filed Sep. 26, 2014 by Sekura et al.; (7) U.S. Pat. No. 9,095,544, entitled “Breeding, Production, Processing and Use of Specialty *Cannabis*”, filed Mar. 17, 2014 by Lewis et al.; (8) U.S. Pat. No. 9,078,838, entitled “Cosmetic or Dermatological Compositions Comprising A Mixture Of Essential Oils, And Its Uses Thereof, Particularly For The Care Of Sensitive Or Sensitized Skin”, filed Sep. 3, 2009 by Andre et al.; (9) U.S. Pat. No. 9,066,910, entitled “Methods and Compositions of *Cannabis* Extracts”, filed Apr. 15, 2010 by Rosenblatt et al.; (10) U.S. Pat. No. 9,050,631, entitled “Apparatus and Related Methods For Extracting Resins From *Cannabis*”, filed Feb. 6, 2013 by Raichart; and (11) U.S. Pat. No. 9,044,390, entitled “Pharmaceutical Composition And Method Of Manufacturing”, filed Apr. 17, 2014

by Speier (the subject matter of these patent documents is incorporated herein in its entirety).

In a second step (step **120**), a *Cannabis* juice purée is formed from the collected raw *Cannabis* material. The *Cannabis* juice purée has a liquid composition and is also referred to as a uniform purée. For example, in FIG. 3, the raw *Cannabis* material **112** is blended in a blender **121** with water **122** and a thickening agent **123** to form a *Cannabis* juice purée. In one example, 210.0 grams of fresh *Cannabis* leaves, 200.0 grams of banana, and 20.0 ounces of filtered water are combined in blender **121** and blended together. The blender **121** is not a juicing machine. Both the shredded *Cannabis* plant material and the extracted *Cannabis* juice remain in the blender after the blending process and become part of the resulting *Cannabis* juice purée.

In accordance with one novel aspect, the *Cannabis* juice purée is formed without a juicing process. In a juicing process, a portion of the *Cannabis* plant material is separated from the juice of the *Cannabis* plant. At least part of the separated *Cannabis* plant material is treated as waste and is disposed. To form the *Cannabis* juice purée, however, all of the *Cannabis* plant material is converted into the *Cannabis* juice purée. The resulting *Cannabis* juice purée includes all of the *Cannabis* plant material placed in the blender and all of the extracted *Cannabis* juice that is extracted in the blending process. No waste product is generated in forming the *Cannabis* juice purée. Accordingly, the *Cannabis* juice purée has all of the *Cannabis* plant material and is rich in dietary fibers and non-cannabinoid components that include terpenes, fatty acids, aminoacids, enzymes, vitamins, minerals, carotenoids, chlorophyll, and flavonoids.

The water **122** may be filtered water, unfiltered water, ice formed from filtered water, or ice formed from unfiltered water. Alternatively, fruit juice or vegetable juice can be used in addition to or instead of water. The thickening agent **123** aids in suspending the *Cannabis* material throughout thereby yielding a more uniform distribution of cannabinoids than would otherwise be achieved without the thickening agent **123**. If no thickening agent **123** is used, then blending the *Cannabis* material **112** and water **122** results in a mixture having the *Cannabis* material sinking to the bottom with water disposed above the *Cannabis* material. The thickening agent **123** may be banana, avocado, psyllium husk, tapioca, or any other food-grade thickening agent.

In a third step (step **130**), the *Cannabis* juice purée is deposited into molds of a tray. The tray has a plurality of molds each having a substantially identical size, shape, and volume. Depositing the *Cannabis* juice purée into similar molds results in each cube having a substantially similar cannabinoid profile. For example, in FIG. 4, the *Cannabis* juice purée **131** is deposited into molds **132** of a tray **133**. In the embodiment of FIG. 4, the tray **133** has fifteen cubic shaped molds that each holds one fluid ounce. The size, shape, and volume of each mold and the number of molds on the tray are selected depending on the desired size of the frozen *Cannabis* juice purée cubes and amount of cannabinoids to be delivered in each dose.

In a fourth step (step **140**), the tray of molds having the *Cannabis* juice purée are frozen to form frozen structures of *Cannabis* juice purée. In one example, frozen structures of *Cannabis* juice purée are frozen *Cannabis* juice purée cubes. In FIG. 5, for example, the tray **133** of molds **132** having the *Cannabis* juice purée **131** is placed in a freezer **141** so that the *Cannabis* juice purée **131** in each mold of tray **133** can freeze. The temperature within freezer **141** is typically between 0.0° F. and 5.0° F., but may be less than 0.0° F. Freezing the *Cannabis* juice purée promotes preservation

15

because harvested raw *Cannabis* material is not acceptable for consumption after three days, even when the *Cannabis* material is stored in a refrigerator. However, by freezing the *Cannabis* juice purée to form frozen *Cannabis* juice purée cubes, the shelf-life is extended for at least six months if the frozen *Cannabis* juice purée cubes are properly stored in a freezer.

In a fifth step (step 150), the frozen structures of *Cannabis* juice purée are packaged into a package. The frozen structures of *Cannabis* juice purée are packaged in a vacuum sealed package, a bag, or a container having a detachable lid. The frozen structures may be loosely packed or may directly contact each other. In the example of FIG. 6, the frozen *Cannabis* juice purée cubes 151 are removed from the molds 132 of the tray 133 and are placed on vacuum sealed bag 152. The vacuum sealed bag 152 is sealed by vacuum sealing machine 153 to form a vacuum sealed package having the frozen *Cannabis* juice purée cubes 151.

FIG. 7 is a perspective diagram of a package 154 with the frozen *Cannabis* juice purée cubes 151. The frozen *Cannabis* juice purée cubes 151 have non-decarboxylated cannabinoids because the *Cannabis* material 112 involved in forming the cubes 151 has not been heated. The package 154 delivers the frozen *Cannabis* juice purée cubes 151 cheaply because the only packaging material involved is the vacuum sealed bag. The package 154 provides for optimal storing, packing, and transporting because the packages are rectangular or square and have flat surfaces that allow the packages to be stacked above each other. The frozen *Cannabis* juice purée cubes 151 consume over 95% of the total volume of package 154 allowing for maximum delivery of frozen *Cannabis* juice purée cubes per shipment of packages.

FIG. 8 is a side view of the package 154 with the cubes 151. The package 154 has an upper portion 155 and a lower portion 156. Each of the cubes 151 has an upper surface 157 and a lower surface 158. Each upper surface 157 of the cubes contacts the upper portion 155 of the package 154 and each lower surface 158 of the cubes 151 contacts a lower portion 156 of the package 154. No packaging material is disposed within the package.

FIG. 9 is top view of the package 154 with the frozen *Cannabis* juice purée cubes 151. The frozen *Cannabis* juice purée cubes 151 are packaged in an array formation. Each of the frozen *Cannabis* juice purée cubes 151 has a substantially identical shape and each cube is adjacent to at least one other cube. Reference numeral 159 identifies a surface of one cube adjacent to a surface of another cube. Each cube has at least two surfaces that are adjacent to surfaces of at least two other cubes.

Reference numeral 160 identifies a cube along a corner of the array of cubes 151 having a first surface that is adjacent to a surface of a second cube and a second surface that is adjacent to a surface of a third cube. Cube 160 has two surfaces each of which contacts a surface of one of two other cubes. Reference numeral 161 identifies a cube along an edge of the array of cubes 151 having a first surface that is adjacent to a surface of a second cube, a second surface that is adjacent to a surface of a third cube, and a third surface that is adjacent to a surface of a fourth cube. Cube 161 has three surfaces each of which contacts a surface of one of three other cubes. Reference numeral 162 identifies a cube at an inner portion of the array of cubes 151 having a first surface that is adjacent to a surface of a second cube, a second surface that is adjacent to a surface of a third cube, a third surface that is adjacent to a surface of a fourth cube, and a fourth surface that is adjacent to a surface of a fifth

16

cube. Cube 162 has four surfaces each of which contacts a surface of one of four other cubes.

In accordance with at least one novel aspect, the cubes 151 are not contained in separate containers. No packaging material is present between the cubes 151. Although a gap is shown between the cubes 151, some or all of the cubes 151 may be directly contacting each other. The tight packing of the cubes 151 and the omission of additional packaging material between the cubes significantly reduces packaging, storing, and shipping costs.

In another example, the frozen *Cannabis* juice purée cubes 151 are loosely packed in a bag without vacuum sealing. Costs and packaging time are substantially reduced by not vacuum sealing. Not all of the cubes 151 contact a surface of the bag. Some of the cubes in the bag are surrounded by other cubes and do not touch a surface of the bag. In yet another example, the frozen *Cannabis* juice purée cubes 151 are loosely packed in a plastic container having a lid. Not all of the cubes contact a surface of the plastic container. Depending on the size of the container, the cubes may not contact the lid of the container.

FIG. 10A is a perspective diagram of frozen *Cannabis* juice purée cubes 151 having an amount of non-decarboxylated cannabinoids. The amount of non-decarboxylated cannabinoids comprises an amount of tetrahydrocannabinolic acid (THCa) and an amount of cannabidiolic acid (CBDa). The cubes 151 do not include any decarboxylated cannabinoids and the cubes 151 are not psychoactive. Each of cubes 151 is a frozen cube of one fluid ounce and has ten milligrams of THCa and fifteen milligrams of CBDa. The ratio of CBDa to THCa is 3:2. In other examples, each frozen structure has between 0.1 fluid ounce and 5.0 fluid ounces of *Cannabis* juice purée. Each cube comprises *Cannabis* plant material that includes leaves, stems, flowers, or trichomes of the *Cannabis* plant. Each cube can be modified to include or exclude non-cannabinoid components of the *Cannabis* plant such as terpenes, fatty acids, aminoacids, enzymes, vitamins, minerals, carotenoids, chlorophyll, flavonoids, and dietary fibers.

In the example of FIG. 10A, the amount of CBDa in each cube is greater than the amount of THCa. In other embodiments, each cube has ratio of CBDa to THCa taken from the group consisting of: 2 CBDa to 1 THCa, 1 CBDa to 1 THCa, 1 CBDa to 2 THCa, 1 CBDa to 3 THCa, 3 CBDa to 1 THCa, 0 CBDa to 1 THCa (no CBDa, only THCa), and 1 CBDa to 0 THCa (no THCa, only CBDa). An artisan will appreciate that another combination of cannabinoids (amount, type, or ratio) can be selected to form the cubes according to the type of ailment being targeted.

FIG. 10B is a perspective diagram of another embodiment of the frozen structures where an amount of non-decarboxylated high concentrate *Cannabis* extract has been added to the *Cannabis* juice purée prior to freezing. High concentrate *Cannabis* extract is also referred to as "kief". The added amount of non-decarboxylated high concentrate *Cannabis* extract substantially increases the amount of non-decarboxylated cannabinoids in each cube. For example, in addition to the 25 milligrams of non-decarboxylated cannabinoids derived from the *Cannabis* leaf, there is an additional 500 milligrams of non-decarboxylated cannabinoids in each cube derived from the added non-decarboxylated high concentrate *Cannabis* extract. The amount of cannabinoids from the non-decarboxylated high concentrate *Cannabis* extract is at least ten times the amount of non-decarboxylated cannabinoids from the raw *Cannabis* plant. The high concen-

trate *Cannabis* extract is obtained through numerous processes and added to the cubes, as explained below in connection with FIG. 10C.

FIG. 10C is a diagram of a female *Cannabis* plant with flowers 165 having trichomes 164. The high concentrate *Cannabis* extract is obtained by collecting the trichomes 164 from many *Cannabis* plants. The trichomes 164 are typically present along an upper surface of a *Cannabis* flower 165. Each trichome has a stalk 166 and a gland head 167. Secretory vesicles along the gland head 167 receive nutrients and turn them into cannabinoids. As flowering progresses, cannabinoids accumulate on an outer layer of the gland head 167. Generally, the greatest concentration of cannabinoids in a *Cannabis* plant is found in the trichomes 164. The high concentrate *Cannabis* extract is obtained by extracting the cannabinoids from the trichomes 164 of the *Cannabis* plant. High concentrate *Cannabis* extract is any material that has a greater percentage of cannabinoids per unit mass than *Cannabis* in its unprocessed and natural occurring state, such as in the leaves 168 or stem 169. The high concentrate *Cannabis* extract is also referred to as “kief” or “high potency resin extract”.

Several techniques exist to obtain high concentrate *Cannabis* extract. A first technique to obtain high concentrate *Cannabis* extract involves sifting or tumbling raw *Cannabis* flower material. The *Cannabis* material that contains trichome—the cannabinoid crystals—is generally present in the *Cannabis* flower material. Agitating and sifting the flower material causes the trichome crystals to separate from the plant material. By employing this technique, the high concentrate *Cannabis* extract will have much higher percentage of cannabinoids per gram. It is not uncommon for high concentrate *Cannabis* extract to contain between 30% and 60% cannabinoids per gram. This could result in at least between 300 milligrams and 600 milligrams of cannabinoids (THCa or CBDa) per gram of high concentrate *Cannabis* extract. When adding raw kief to frozen *Cannabis* juice purée cubes, each gram of high concentrate *Cannabis* extract added to the cube can increase the amount of cannabinoids per ounce of cube by between 300 milligrams and 600 milligrams.

A second type of high concentrate *Cannabis* extract is obtained by using CO₂ extraction, alcohol extraction, or other forms of high concentrate extraction using solvents or alcohols. High concentrate *Cannabis* extract obtained through these other extractions methods may be obtained and added to the frozen *Cannabis* juice purée cubes prior to freezing or after freezing. Such high concentrate extraction, when performed with high quality precision equipment, results in considerably high concentrate *Cannabis* extract or oils with almost undetectable amounts of the solvent remaining. If the resulting high concentrate *Cannabis* extract are never heated (decarboxylated), these high concentrate *Cannabis* extract or oils can be added to the *Cannabis* juice purée to dramatically increase the amount of cannabinoids per cube.

In one example, while pouring the *Cannabis* juice purée into the molds, an amount of high concentrate *Cannabis* extract is weighed and added into each of the individual molds. For example, the *Cannabis* juice purée is filled to half the volume of the mold. Next, the high concentrate *Cannabis* extract is deposited into the half filled mold. Next, the remainder of the mold is filled with the *Cannabis* juice purée. This would maintain the high concentrate *Cannabis* extract in a center of the frozen *Cannabis* juice purée cubes. In another example, while blending the raw *Cannabis* material, high concentrate *Cannabis* extract is added to the entire

Cannabis juice purée. This is not as preferred, as some of the valuable high concentrate *Cannabis* extract could be lost in the residue on the side of the mixing or blending apparatus.

By adding high concentrate *Cannabis* extract to the cubes, the concentration of cannabinoids per cube can be increased to over 600 mg of cannabinoids per cube, if an entire gram of high concentrate *Cannabis* extract were added per cube. In one specific embodiment, 500 milligrams of high concentrate *Cannabis* extract is added in each cannabinoid cube. An artisan of ordinary skill will appreciate that employing high concentrate *Cannabis* extract allows for a completely ‘natural’ way to achieve very high cannabinoid potency per cube. In addition, there are no solvents or alcohol used to extract the high concentrate *Cannabis* extract thereby reducing costs and production time and yields ‘food grade’ frozen *Cannabis* juice purée cubes.

FIG. 10D is a table 170 showing various non-cannabinoid components and cannabinoid components that are obtainable from *Cannabis* plant material. The left-side column of table 170 shows non-cannabinoid components that can be obtained from the *Cannabis* plant. The non-cannabinoid components include terpenes, fatty acids, aminoacids, enzymes, vitamins, minerals, carotenoids, chlorophyll, flavonoids, and dietary fibers. The right-side column of table 170 shows cannabinoid components that can be obtained from the *Cannabis* plant. The cannabinoid components include cannabigerolic acid (CBGa), cannabigerovarin acid (CBGVA), tetrahydrocannabinolic acid (THCA), tetrahydrocannabivarin carboxylic acid (THCVA), cannabidiolic acid (CBDA), cannabidivarin acid (CBDVA), cannabichrome carboxylic acid (CBCA), cannabichrome varinic acid (CBCVA), tetrahydrocannabinol (THC), tetrahydrocannabidivarin (THCV), tetrahydrocannabivarin acid (THVA), cannabidiol (CBD), cannabidivarin (CBDV), cannabichromene (CBC), cannabichromevarin (CBCV), cannabigerol (CBG), cannabigerovarin (CBGV), cannabimerolic acid (CBNA), cannabigerovarinic acid (CBNVA), cannabimol (CBN), cannabicyclol (CBL), and cannabicyclol acid (CBLA).

FIG. 11 is a table 163 showing two general types of non-decarboxylated cannabinoids, THCa and CBDa, along with their chemical names and structural formulas. The non-decarboxylated cannabinoids include a carboxyl group (COOH).

FIG. 12 is a flowchart of a method 200 in accordance with a second embodiment. The method 200 is a method of manufacturing and packaging a plurality of frozen structures of *Cannabis* juice purée that comprises a pre-determined amount of non-decarboxylated and decarboxylated cannabinoids. The amount of decarboxylated cannabinoids in each frozen structure is at least 5 mg. A structure with less than 5 mg is not considered to be a therapeutic dose of decarboxylated cannabinoids because consuming less than 5 mg decarboxylated cannabinoids has negligible, if any, effects on the user. The amount of decarboxylated cannabinoids may include one type of decarboxylated cannabinoid (such as CBD) or more than one type of decarboxylated cannabinoid (such as CBD and THC).

Non-decarboxylated cannabinoids exhibit therapeutic benefits without psychoactive side effects. Decarboxylated cannabinoids also offer therapeutic benefits but may be considered psychoactive depending on the amount of THC present. Decarboxylated cannabinoids are typically produced by heating raw *Cannabis* material. By providing the pre-determined amount of non-decarboxylated cannabinoids

and decarboxylated cannabinoids in a single frozen structure, therapeutic results in treating certain medical conditions are achieved.

In a first step (step 210), raw *Cannabis* material is collected. For example, in FIG. 13, raw *Cannabis* material 211 is collected from a first *Cannabis* plant 212 and a second *Cannabis* plant 213. A first portion 214 of the raw *Cannabis* material 211 is obtained from the first *Cannabis* plant 212. The first portion 214 has a first cannabinoid profile 215 of 3 CBDa to 2 THCa. A second portion 216 of the raw *Cannabis* material 211 is obtained from the second *Cannabis* plant 213. The second portion 216 has a second cannabinoid profile 217 of 30 CBDa to 1 THCa. The second portion 216 of the raw *Cannabis* material 211 will eventually be heated to obtain decarboxylated cannabinoids. At step 210, the first portion 214 and second portion 216 in FIG. 13 are non-decarboxylated as both are raw *Cannabis* material that has not been heated.

The amounts of non-decarboxylated and decarboxylated cannabinoids can be created in unlimited combinations based on using different strains of *Cannabis* which have different ratios of THCa and CBDa. In this example, the second portion 216 has a second cannabinoid profile 217 different from the first cannabinoid profile 215. In other embodiments, the first portion 214 and the second portion 216 have the same cannabinoid profile. Other cannabinoid profiles for the first portion include: 2 CBDa to 1 THCa, 1 CBDa to 1 THCa, 1 CBDa to 2 THCa, 1 CBDa to 3 THCa, 3 CBDa to 1 THCa, 0 CBDa to 1 THCa (no CBDa, only THCa), and 1 CBDa to 0 THCa (no THCa, only CBDa). Other cannabinoid profiles for the second portion include: 20 CBD to 1 THC, 10 CBD to 1 THC, or 5 CBD to 1 THC. A skilled artisan will appreciate that other cannabinoid profiles are obtainable.

In a second step (step 220), a non-decarboxylated *Cannabis* juice purée is formed from the first portion of collected raw *Cannabis* material and a decarboxylated *Cannabis* infusion is formed from the second portion of collected raw *Cannabis* material. Forming the non-decarboxylated *Cannabis* juice purée does not involve heating the raw *Cannabis* material. For example, in FIG. 14, the first portion of raw *Cannabis* material 214 is blended in a blender 221 with water 222 and a thickening agent 223 to form a non-decarboxylated *Cannabis* juice purée. In one example, 210.0 grams of fresh *Cannabis* leaves 214, 200.0 grams of banana 223, and 20.0 ounces of filtered water 222 are combined in blender 221 and blended together. The blender 221 is not a juicing machine. Both the *Cannabis* plant material and the extracted *Cannabis* juice remain in the blender after blending and become part of the resulting *Cannabis* juice purée. The water 222 may be filtered water, unfiltered water, ice formed from filtered water, or ice formed from unfiltered water. The thickening agent 223 aids in suspending the *Cannabis* material yielding a more uniform mixture than would be achieved without the thickening agent 223. The thickening agent 223 may be banana, avocado, psyllium husk, tapioca, corn starch, or any other food-grade thickener.

The *Cannabis* juice purée is formed without a juicing process. In a juicing process, a portion of the *Cannabis* plant material is separated from the juice of the *Cannabis* plant. At least part of the separated *Cannabis* plant material is treated as waste and is disposed. To form the *Cannabis* juice purée, however, all of the *Cannabis* plant material is converted into the *Cannabis* juice purée. The resulting *Cannabis* juice purée includes all of the *Cannabis* plant material placed in the blender and all of the extracted *Cannabis* juice that is extracted in the blending process. No waste product is

generated in forming the *Cannabis* juice purée. Accordingly, the *Cannabis* juice purée has all of the *Cannabis* plant material and is rich in dietary fibers and non-cannabinoid components that include terpenes, fatty acids, aminoacids, enzymes, vitamins, minerals, carotenoids, chlorophyll, flavonoids, and dietary fibers.

Forming the decarboxylated *Cannabis* infusion involves heating the second portion of collected raw *Cannabis* material. For example, in FIG. 15, the second portion of raw *Cannabis* material 216 is heated along with fatty oil 224 in a heating mechanism 225. A typical ratio is one ounce of dried *Cannabis* flower mixed with six cups of olive or coconut oil and is heated in a heating mechanism 225 for one to eight hours to create the decarboxylated *Cannabis* infusion. The heating mechanism 225 shown in FIG. 15 is a crock pot.

In another example, the decarboxylated cannabinoid is generated by heating dried *Cannabis* flower in an oven without oil. For example, the dried *Cannabis* flower is heated in an oven at 240° F. for thirty to forty minutes. Other conventional methods for generating decarboxylated *Cannabis* may be employed.

In a third step (step 230), the non-decarboxylated *Cannabis* juice purée and the decarboxylated *Cannabis* infusion are deposited into molds of a tray such that each mold has non-decarboxylated and decarboxylated cannabinoids. The tray has a plurality of molds each having a substantially identical size, shape, and volume. Depositing the *Cannabis* juice purée and *Cannabis* infusion into similar molds results in each cube having a substantially similar cannabinoid profile. For example, in FIG. 16, the non-decarboxylated *Cannabis* juice purée 231 and the decarboxylated *Cannabis* infusion 234 are deposited into molds 232 of a tray 233. First, the non-decarboxylated *Cannabis* juice purée 231 is deposited into each mold 232 to fill approximately half of the mold 232. Next, the decarboxylated *Cannabis* infusion 234 is deposited at a center location on the top surface of the half-filled mold. In this example, a measuring syringe 235 is employed to deposit a particular amount decarboxylated *Cannabis* infusion 234 into the molds 232. Next, the non-decarboxylated *Cannabis* juice purée 231 is deposited into each mold above the layer of decarboxylated *Cannabis* infusion 234 to fill the rest of each mold 232.

In the embodiment of FIG. 16, the tray 233 has fifteen cubic shaped molds that each holds one fluid ounce. The size, shape, and volume of each mold and the number of molds on the tray are selected depending on the desired size of the frozen *Cannabis* juice purée cubes and amount of cannabinoids to be delivered in each dose.

In another example, the decarboxylated *Cannabis* infusion is deposited directly into the non-decarboxylated *Cannabis* juice purée 231 in the blender 221 of FIG. 14. The resulting mixture has generally uniform distribution of decarboxylated cannabinoids and non-decarboxylated cannabinoids that is deposited into the molds of the tray. No syringe 235 is needed using this technique.

In a fourth step (step 240), the tray of molds having the *Cannabis* juice purée and decarboxylated *Cannabis* infusion are frozen to form frozen *Cannabis* juice purée cubes having non-decarboxylated cannabinoids and decarboxylated cannabinoids. For example, in FIG. 17, the tray 233 having the non-decarboxylated *Cannabis* juice purée 231 and the decarboxylated *Cannabis* infusion 234 is placed in a freezer 242 so that the non-decarboxylated *Cannabis* juice purée 231 and the decarboxylated *Cannabis* infusion 234 in each mold 232 of tray 233 can freeze. The temperature within freezer 242 is typically between 0.0° F. and 5.0° F., but may be less

21

than 0.0° F. Freezing the *Cannabis* juice purée promotes preservation because harvested raw *Cannabis* material is not acceptable for consumption after three days, even when the *Cannabis* material is stored in a refrigerator. However, by freezing the *Cannabis* juice purée to form frozen *Cannabis* juice purée cubes, the shelf-life is extended for at least six months if the frozen *Cannabis* juice purée cubes are properly stored in a freezer.

In a fifth step (step 250), the cubes having non-decarboxylated cannabinoids and decarboxylated cannabinoids are packaged into a package. The frozen *Cannabis* juice purée cubes are packaged in a vacuum sealed package, a bag, or a container having a detachable lid. For example, in FIG. 18, the frozen *Cannabis* juice purée cubes 251 are removed from the molds 232 of the tray 233 and are placed on vacuum sealed bag 252. The vacuum sealed bag 252 is sealed by vacuum sealing machine 253 to form a vacuum sealed package having the frozen *Cannabis* juice purée cubes 251.

FIG. 19 is a perspective diagram of a package 254 with the frozen *Cannabis* juice purée cubes 251. The frozen *Cannabis* juice purée cubes 251 have non-decarboxylated cannabinoids and decarboxylated cannabinoids. The package 254 delivers the frozen *Cannabis* juice purée cubes 251 cheaply because the only packaging material involved is the vacuum sealed bag 252. The package 254 provides for optimal storing, packing, and transporting because the packages are rectangular or square and have flat surfaces that allow the packages to be stacked above each other. The frozen *Cannabis* juice purée cubes 251 consume over 95% of the total volume of package 254 allowing for maximum delivery of frozen *Cannabis* juice purée cubes per shipment of packages.

FIG. 20 is a side view of the package 254 with the frozen *Cannabis* juice purée cubes 251. The package 254 has an upper portion 255 and a lower portion 256. Each of the cubes 251 has an upper surface 257 and a lower surface 258. Each upper surface 257 of the cubes contacts the upper portion 255 of the package 254 and each lower surface 258 of the cubes 251 contacts a lower portion 256 of the package 254. No packaging material is disposed within the package.

FIG. 21 is top view of the package 254 with the frozen *Cannabis* juice purée cubes 251. The frozen *Cannabis* juice purée cubes 251 are packaged in an array formation. Each of the frozen *Cannabis* juice purée cubes 251 has a substantially identical shape and each cube is adjacent to at least one other cube. Reference numeral 259 identifies a surface of one cube adjacent to a surface of another of the cubes. Each frozen *Cannabis* juice purée cube has at least two surfaces that are adjacent to surfaces of at least two other cubes.

Reference numeral 260 identifies a frozen *Cannabis* juice purée cube along a corner of the array of cubes 251 having a first surface that is adjacent to a surface of a second cube and a second surface that is adjacent to a surface of a third cube. Cube 260 has two surfaces each of which contacts a surface of one of two other cubes. Reference numeral 261 identifies a frozen *Cannabis* juice purée cube along an edge of the array of cubes 251 having a first surface that is adjacent to a surface of a second cube, a second surface that is adjacent to a surface of a third cube, and a third surface that is adjacent to a surface of a fourth cube. Cube 261 has three surfaces each of which contacts a surface of one of three other cubes. Reference numeral 262 identifies a frozen *Cannabis* juice purée cube at an inner portion of the array of cubes 251 having a first surface that is adjacent to a surface of a second cube, a second surface that is adjacent to a surface of a third cube, a third surface that is adjacent to a

22

surface of a fourth cube, and a fourth surface that is adjacent to a surface of a fifth cube. Cube 262 has four surfaces each of which contacts a surface of one of four other cubes.

In accordance with at least one novel aspect, the frozen *Cannabis* juice purée cubes 251 are not contained in separate containers. No packaging material is present between the frozen *Cannabis* juice purée cubes 251. Although a gap is shown between the cubes 251, some or all of the cubes 251 may be directly contacting each other. The tight packing of the cubes 251 significantly reduces packaging, storing, and shipping costs.

In another example, the frozen *Cannabis* juice purée cubes 251 are loosely packed in a bag without vacuum sealing. Costs and packaging time are substantially reduced by not vacuum sealing. Not all of the cubes contact a surface of the bag. Some of the cubes in the bag are surrounded by other cubes and do not touch a surface of the bag. In yet another example, the frozen *Cannabis* juice purée cubes 251 are loosely packed in a plastic container having a lid. Not all of the cubes contact a surface of the plastic container. Depending on the size of the container, the cubes may not contact the lid of the container.

FIG. 22A is a perspective diagram of frozen *Cannabis* juice purée cubes 251 having an amount of non-decarboxylated cannabinoids and an amount of decarboxylated cannabinoids. The amount of non-decarboxylated cannabinoids comprises an amount of tetrahydrocannabinolic acid (THCa) and an amount of cannabidiolic acid (CBDa). The amount of decarboxylated cannabinoids comprises an amount of tetrahydrocannabinol (THC) and an amount of cannabidiol (CBD). Each of cubes 251 is a frozen cube of one fluid ounce and has 10 mg of THCa, 1 mg of THC, 15 mg of CBDa, and 30 mg of CBD. In this example, the ratio of CBDa to THCa is 3:2 and the ratio of CBD to THC is 30:1. The amount of CBDa in each cube is greater than the amount of THCa, and the amount of CBD in each cube is greater than the amount of THC. The frozen *Cannabis* juice purée cubes may be made to include or exclude non-cannabinoid components that include terpenes, fatty acids, aminoacids, enzymes, vitamins, minerals, carotenoids, chlorophyll, flavonoids, and dietary fibers.

FIG. 22B is a perspective diagram of another embodiment of frozen structures of *Cannabis* juice purée having decarboxylated *Cannabis* infusion and non-decarboxylated high concentrate *Cannabis* extract. In the example of FIG. 22B, the frozen structures have 25 mg of non-decarboxylated cannabinoids from raw *Cannabis* plant, 31 mg of decarboxylated cannabinoids from decarboxylated *Cannabis* infusion, 500 mg of non-decarboxylated cannabinoids from non-decarboxylated high concentrate *Cannabis* extract. The added amount of non-decarboxylated high concentrate *Cannabis* extract substantially increases the amount of cannabinoids in each frozen structure. In this example, the non-decarboxylated high concentrate *Cannabis* extract adds an additional 500 mg of non-decarboxylated cannabinoids in each structure. The amount of non-decarboxylated cannabinoids from the non-decarboxylated high concentrate *Cannabis* extract is at least ten times the amount of non-decarboxylated cannabinoids derived from the raw *Cannabis* plant. The high concentrate *Cannabis* extract is obtained through numerous processes and included in the frozen structures as explained above in connection with FIG. 10B.

FIG. 22C is a perspective diagram of another embodiment of frozen structures of *Cannabis* juice purée having decarboxylated high concentrate *Cannabis* extract. In the example of FIG. 22C, the frozen structures have 25 mg of non-

decarboxylated cannabinoids from raw *Cannabis* plant and 105 mg of decarboxylated cannabinoids from decarboxylated high concentrate *Cannabis* extract. The added amount of decarboxylated high concentrate *Cannabis* extract substantially increases the amount of cannabinoids in each frozen structure. In this example, the decarboxylated high concentrate *Cannabis* extract adds an additional 105 mg of decarboxylated cannabinoids to each structure. The decarboxylated high concentrate *Cannabis* extract is obtained by heating the high concentrate *Cannabis* extract obtained through numerous processes described above in connection with FIG. 10B. A few techniques are described below.

The high concentrate *Cannabis* extract is decarboxylated by first heating the non-decarboxylated high concentrate *Cannabis* extract on a dish in an oven at temperatures between 212° F. and 340° F. The high concentrate *Cannabis* extract becomes decarboxylated as a result of heating thus converting the THCa and CBDa to THC and CBD, respectively, as well as other decarboxylated cannabinoids. This results in a substantially high potency of THC and CBD, for example, approximately 30% and 60% decarboxylated cannabinoids per gram. In a second technique, the *Cannabis* flower and flower trim can also be decarboxylated in an oven at temperatures between 212° F. and 340° F. This would result in plant material being decarboxylated at between about 10% and 30% decarboxylated cannabinoids per gram. The percentage yield in this technique is less due to plant material. In a third technique, the high concentrate *Cannabis* extract or *Cannabis* flower can also be added to a food grade oil mixture and heated to between 212° F. and 340° F. Such food grade oil mixture is selected from the group consisting of olive oil, coconut oil, avocado oil, or similar cooking oil. A crockpot or pressure cooker can be employed to heat the oils. The result of this technique is an infused oil that contains decarboxylated cannabinoids comprising between 100 mg and 300 mg of cannabinoids per fluid ounce.

To incorporate the decarboxylated high concentrate *Cannabis* into the frozen structures, several techniques may be employed. In one example, while pouring the *Cannabis* juice purée into the molds, an amount of decarboxylated high concentrate *Cannabis* extract is weighed and added into each of the individual molds. For example, the *Cannabis* juice purée is filled to half the volume of the mold. Next, the decarboxylated high concentrate *Cannabis* extract is deposited. Next, the remainder of the mold is filled with the *Cannabis* juice purée. This would maintain the decarboxylated high concentrate *Cannabis* extract within a center of the frozen *Cannabis* juice purée cubes. In another example, while blending the raw *Cannabis* material, decarboxylated high concentrate *Cannabis* extract is added to the entire *Cannabis* juice purée. The resulting *Cannabis* juice purée would have a uniform amount of the decarboxylated high concentrate *Cannabis* extract. This is not as preferred, as some of the valuable decarboxylated high concentrate *Cannabis* extract could be lost in the residue on the side of the mixing or blending apparatus. Depending on the potency desired, any amount of decarboxylated high concentrate *Cannabis* extract can be added to the *Cannabis* juice purée.

The amounts and types of cannabinoids varies and is selected according to the desired potency and amount desired. For example, non-decarboxylated frozen *Cannabis* juice purée cubes that do not have the high concentrate *Cannabis* extract range between 5 mg and 200 mg of non-decarboxylated cannabinoid per fluid ounce of cube. Non-decarboxylated frozen *Cannabis* juice purée cubes that do have the high concentrate *Cannabis* extract range between 5 mg and 2,500 mg of non-decarboxylated can-

nabinoid per fluid ounce of cube. Decarboxylated frozen *Cannabis* juice purée cubes that have the high concentrate *Cannabis* extract range between 5 mg and 2,500 mg of non-decarboxylated cannabinoids per fluid ounce of cube and between 5 mg and 2,500 mg of decarboxylated cannabinoids per fluid ounce of cube. Decarboxylated frozen *Cannabis* juice purée cubes that have the decarboxylated oil or flower described above range between 5 mg and 2,500 mg of non-decarboxylated cannabinoids per fluid ounce of cube and between 5 mg and 2,500 mg of decarboxylated cannabinoids per fluid ounce of cube.

FIG. 22D is a perspective diagram of another embodiment of frozen structures of *Cannabis* juice purée having decarboxylated high concentrate *Cannabis* extract and non-decarboxylated high concentrate *Cannabis* extract. In the example of FIG. 22D, the frozen structures have 25 mg of non-decarboxylated cannabinoids from raw *Cannabis* plant, 105 mg of decarboxylated cannabinoids from decarboxylated high concentrate *Cannabis* extract, and 500 mg of non-decarboxylated cannabinoids from non-decarboxylated high concentrate *Cannabis* extract.

FIG. 23 is a table 263 showing two general types of decarboxylated cannabinoids, THC and CBD, along with their chemical names and structural formulas. The decarboxylated cannabinoids are formed through a decarboxylation process that removes the carboxyl group (COOH).

FIG. 24 is a flowchart of a method 300 in accordance with another novel aspect. In a first step (step 310), a plurality of packages having frozen structures of *Cannabis* juice purée is stored. For example, in FIG. 25, a plurality of packages 311 is stored in a freezer 312. The packages 311 are stored by stacking each package above another package. For example, package 313 is disposed above package 314. Package 315 is to be placed above package 313. Each of the packages comprises a plurality of frozen *Cannabis* juice purée cubes 316. At least one of the frozen *Cannabis* juice purée cubes contacts the package. Each package has at least two flat surfaces due to the uniform size and shape of each cube 316. Accordingly, the packages 311 stack compactly in the freezer 312. If, on the other hand, the cubes within in each package were not uniform in size and shape, then the packages would not have flat surfaces adapted for stacking. Additionally, by not placing each cube in a separate package and by not including any additional packaging materials between the package 315 and each cube 316, each package consumes minimal space in freezer 312 thereby increasing the number of packages that can be stored per unit volume of storage capacity.

FIG. 26 is a perspective diagram of a tray 400 having a plurality of molds 401. All of the molds 401 have a substantially identical structure thereby yielding cubes having a consistent size and dosage of cannabinoids. In this example, each mold is cubic shaped and holds one fluid ounce. In other embodiments, the molds may be smaller or larger depending on the desired size of the cubes. The volume of each mold 401 is typically between 0.125 cubic inches (0.5 inches×0.5 inches×0.5 inches) and 8.0 cubic inches (2.0 inches×2.0 inches×2.0 inches). An artisan of ordinary skill appreciates that the molds may be larger or shaped differently. Other trays may be selected that frozen structures of *Cannabis* juice purée of between 0.1 fluid ounce and 5.0 fluid ounces of *Cannabis* juice purée.

FIG. 27 is a top view of the tray 400 having a plurality of molds 401.

25

Other frozen structures of *Cannabis* juice purée may be formed having different shapes. FIGS. 28-36 show how the frozen structures may be formed into various other shapes that are non-cubic.

FIG. 28 is a top view of a tray 403 having a plurality of cylindrical shaped molds.

FIG. 29 is a top view of a tray 404 having a plurality of rectangular shaped molds.

FIG. 30 is a top view of a tray 405 having a plurality of hexagonal shaped molds.

FIG. 31 is a top view of a tray 406 having a plurality of triangular shaped molds.

FIG. 32 is a top view of a tray 407 having a plurality of star shaped molds.

FIG. 33 is a top view of a tray 408 having a plurality of trapezoidal shaped molds.

FIG. 34 is a top view of a tray 409 having a plurality of concave shaped molds.

FIG. 35 is a top view of a tray 410 having a plurality of parallelogram shaped molds.

FIG. 36 is a top view of a tray 411 having a plurality of leaf shaped molds.

FIG. 37 is a diagram of a conventional coconut milk based *Cannabis* ice cream 420. The coconut milk based *Cannabis* ice cream 420 is packaged in a container 421 having a lid 422. The conventional coconut milk based *Cannabis* ice cream 420 is available from Ohana Farms at (<http://www.ohanaedu.org/index.php/products/cbd-cubes/>). The conventional coconut milk based *Cannabis* ice cream 420 has a soft, ice-cream texture and requires separate packaging for each dose of ice cream 420.

FIG. 38 is a diagram showing how the container 421 is placed onto a container holder 423. The container holder 423 includes a retainer opening 424 into which the container 421 is placed. The container holder 423 includes six retainer openings and holds up to six of the containers 421.

FIG. 39 is a diagram showing how the container holder 423 having six containers is placed into a package 425. The container holder 423 having the six containers is inserted via opening 426. After the container holder 423 having the six containers is inside the package 425, the package 425 is sealed.

FIG. 40 is a diagram of the package 425 containing the container holder 423 having the six containers with coconut milk based *Cannabis* ice creams.

FIG. 41 is a table 500 showing the advantages of novel package 154 (shown in FIG. 7) and novel package 254 (shown in FIG. 19) over the conventional package 425 shown in FIG. 40. The novel packages 154 and 254 exhibit advantages with respect to storage capacity, packaging costs, waste generation, and quantity of cubes per package.

The novel packages 154 and 254 utilize minimal storage capacity as compared to the conventional package 425. The novel packages 154 and 254 have at least two flat surfaces allowing several of the novel packages 154 and 254 to be stacked above each other. The conventional package 425, on the other hand, does not have flat surfaces and does not provide an advantageous utilization of storage space.

The novel packages 154 and 254 involve minimal packaging costs as compared to the conventional package 425. The only packaging involved is the vacuum seal bag, resealable bag, or container in which the novel cubes are stored. At least one of the frozen *Cannabis* juice purée cubes contacts the package. No additional packaging is inserted between the cubes. No additional packaging is inserted between the cubes and the outer package. The conventional package 425, on the other hand, has substantial packaging.

26

For example, each cannabinoid structure is individually packaged in a separate container and covered with a lid. In addition, each of the individual containers is then placed onto a holder. Therefore, the conventional package 425 has significantly greater packaging costs than the novel packages 154 and 254.

The novel packages 154 and 254 generate minimal waste as compared to the conventional package 425. The novel packages 154 and 254 only generate waste from a single package, such as a bag, vacuum sealed bag, or container. The novel packages 154 and 254 may have a label disposed on an outer surface, but no other waste is generated because the entire contents of the novel packages 154 and 254 are consumed. The conventional package 425, on the other hand, generates substantial waste as compared to the novel packages 154 and 254 because of all of the packaging, including six containers, six lids, the container holder, and the outer packaging.

The novel packages 154 and 254 deliver significantly more cannabinoids per unit volume of packaging as compared to the conventional package 425. A single one of the novel packages 154 and 254 delivers twenty cubes due, in part, to the minimal packaging involved. The conventional package 425, on the other hand, only carries six coconut milk based *Cannabis* ice creams.

FIG. 42 is a flowchart of a method 600 in accordance with a third embodiment. The method 600 is a method of manufacturing and packaging a frozen ice pop of *Cannabis* juice purée. In one specific embodiment, the packaged frozen ice pop of *Cannabis* juice purée has an amount of non-decarboxylated cannabinoids and is non-psychoactive. In another specific embodiment, the packaged frozen ice pops of *Cannabis* juice purée has an amount of non-decarboxylated cannabinoids and an amount of decarboxylated cannabinoids. The amount of decarboxylated cannabinoids in each ice pop is at least 5 mg. Decarboxylated *Cannabis* infusion, non-decarboxylated high concentrate *Cannabis* extract, or decarboxylated high concentrate *Cannabis* extract are optionally added to the frozen ice pops of *Cannabis* juice purée.

In a first step (step 610), a *Cannabis* juice purée is formed. To form a frozen ice pop of *Cannabis* juice purée that is non-psychoactive, raw *Cannabis* material having an amount of non-decarboxylated cannabinoids is collected. For example, in FIG. 2, raw *Cannabis* material 112 is collected by trimming leaves 113 from the *Cannabis* plant 111, and in FIG. 3, the raw *Cannabis* material 112 is blended in a blender 121 with water 122 and a thickening agent 123 to form a *Cannabis* juice purée.

To form a packaged frozen ice pop of *Cannabis* juice purée that has decarboxylated cannabinoids, a portion of the collected raw *Cannabis* material is heated. For example, in FIG. 13, raw *Cannabis* material 211 is collected from a first *Cannabis* plant 212 and a second *Cannabis* plant 213. A first portion 214 of the raw *Cannabis* material 211 is obtained from the first *Cannabis* plant 212. Next, the first portion of raw *Cannabis* material 214 is blended in a blender 221 with water 222 and a thickening agent 223 to form a non-decarboxylated *Cannabis* juice purée as shown in FIG. 14. Next, a second portion 216 of the raw *Cannabis* material 211 is obtained from the second *Cannabis* plant 213 as shown in FIG. 13. Next, the second portion of collected raw *Cannabis* material is heated to form a decarboxylated *Cannabis* infusion, as shown for example in FIG. 15. The non-decarboxylated *Cannabis* juice purée and decarboxylated *Cannabis* infusion are combined prior to freezing.

In both the non-decarboxylated and decarboxylated embodiments of the packaged frozen ice pop of *Cannabis* juice purée, a sweetening agent is optionally added to the *Cannabis* juice purée. The sweetening agent is selected from the group consisting of honey, *stevia*, fruit juice, sugar, corn syrup, or any other type of food grade sweetener. The sweetening agent provides a frozen ice pop of *Cannabis* juice purée that is more palatable than if the sweetening agent were not included. Flavoring agents are optionally added to the packaged *Cannabis* juice purée, such as fruit flavor, spice (apple, cherry, mint, tart, etc.), or any other type of food grade flavoring. Fruit juice, fruit, or vegetable material may also be added, such as blueberries, blueberry juice, carrots, or carrot juice.

In a second step (step 620), the *Cannabis* juice purée is deposited into a container. In one example, the container is a tube shaped container made of a flexible material. For example, in FIG. 43, the *Cannabis* juice purée 621 is deposited into container 622 through opening 623. The container 622 is a tube shaped container formed from a thermoplastic polymer such as polypropylene plastic resin. In one example, the opening 623 of the container 622 is resealable. The container 622 with the resealable opening 623 is available from the following internet address: <http://zipzicles.com/>. In one example, the opening 623 of the container 622 is not resealable and is permanently sealed after the *Cannabis* juice purée 621 is deposited into the container 622.

In a third step (step 630), the container having the *Cannabis* juice purée is frozen to form a packaged frozen ice pop of *Cannabis* juice purée. For example, in FIG. 44 the container 622 having the *Cannabis* juice purée 621 is placed in a freezer 631 so that the *Cannabis* juice purée 621 in the container 622 can freeze. The temperature within freezer 631 is typically between 0.0° F. and 5.0° F., but may be less than 0.0° F. Freezing the *Cannabis* juice purée promotes preservation because harvested raw *Cannabis* material is not acceptable for consumption after three days, even when the *Cannabis* material is stored in a refrigerator. However, by freezing the *Cannabis* juice purée to form the packaged frozen ice pop of *Cannabis* juice purée, the shelf-life is extended for at least six months if properly stored in a freezer.

FIG. 45A is a perspective diagram of the packaged frozen ice pop of *Cannabis* juice purée 632 with only non-decarboxylated cannabinoids. The frozen ice pop of *Cannabis* juice purée 632 has a cannabinoid profile 633. The packaged frozen ice pop of *Cannabis* juice purée 632 is formed by carrying out the steps set forth in method 600 such that the *Cannabis* juice purée in the first step (step 610) has only raw, blended *Cannabis* material. None of the collected *Cannabis* material is heated. The packaged frozen ice pop of *Cannabis* juice purée 632 does not include any decarboxylated cannabinoids and the packaged frozen ice pop of *Cannabis* juice purée 632 is not psychoactive. In this example, frozen ice pop of *Cannabis* juice purée 632 has 30 mg of THCa per 3 fluid ounces and 45 mg of CBDA per 3 fluid ounces. The ratio of CBDA to THCa is 3:2. The amount of CBDA in each ice pop is greater than the amount of THCa, and the amount of CBD in each ice pop is greater than the amount of THC. In other embodiments, each ice pop has ratio of CBDA to THCa taken from the group consisting of: 2 CBDA to 1 THCa, 1 CBDA to 1 THCa, 1 CBDA to 2 THCa, 1 CBDA to 3 THCa, 3 CBDA to 1 THCa, 0 CBDA to 1 THCa (no CBDA, only THCa), and 1 CBDA to 0 THCa (no THCa, only CBDA). The frozen ice pop of *Cannabis* juice purée may be made to include or exclude non-cannabinoid components of the

Cannabis plant that include terpenes, fatty acids, aminoacids, enzymes, vitamins, minerals, carotenoids, chlorophyll, flavonoids, and dietary fibers. In yet other embodiments, the frozen ice pop of *Cannabis* juice purée has between 1 mg and 500 mg of THCa and between 1 mg and 500 mg of CBDA. Non-decarboxylated high concentrate *Cannabis* extract may also be added to the frozen ice pop of *Cannabis* juice purée to achieve high concentrations of non-decarboxylated cannabinoids.

FIG. 45B is a perspective diagram of another embodiment of a packaged frozen ice pop of *Cannabis* juice purée with added non-decarboxylated high concentrate *Cannabis* extract. In the example of FIG. 45B, the packaged frozen ice pop of *Cannabis* juice purée has 75 mg of non-decarboxylated cannabinoids from raw *Cannabis* plant and 1,500 mg of non-decarboxylated cannabinoids from non-decarboxylated high concentrate *Cannabis* extract.

FIG. 46A is a perspective diagram of a packaged frozen ice pop of *Cannabis* juice purée 634 with added decarboxylated cannabinoids. The packaged frozen ice pop of *Cannabis* juice purée 634 is formed by carrying out the steps set forth in method 600 such that the *Cannabis* juice purée in the first step (step 610) has raw, blended *Cannabis* material in addition to decarboxylated *Cannabis* infusion. The packaged frozen ice pop of *Cannabis* juice purée 634 includes non-decarboxylated cannabinoids and decarboxylated cannabinoids. In this example, packaged frozen ice pop of *Cannabis* juice purée 634 has 75 mg of non-decarboxylated cannabinoids from raw *Cannabis* plant and 95 mg of decarboxylated cannabinoids from decarboxylated *Cannabis* infusion.

FIG. 46B is a perspective diagram of another embodiment of a packaged frozen ice pop of *Cannabis* juice purée with added decarboxylated *Cannabis* infusion and non-decarboxylated high concentrate *Cannabis* extract. In the example of FIG. 46B, the packaged frozen ice pop of *Cannabis* juice purée has 75 mg of non-decarboxylated cannabinoids from raw *Cannabis* plant, 95 mg of decarboxylated cannabinoids from decarboxylated *Cannabis* infusion, and 1,500 mg of non-decarboxylated cannabinoids from non-decarboxylated high concentrate *Cannabis* extract.

FIG. 46C is a perspective diagram of another embodiment of a packaged frozen ice pop of *Cannabis* juice purée with added decarboxylated high concentrate *Cannabis* extract. In the example of FIG. 46C, the packaged frozen ice pop of *Cannabis* juice purée has 75 mg of non-decarboxylated cannabinoids from raw *Cannabis* plant and 310 mg of decarboxylated cannabinoids from decarboxylated high concentrate *Cannabis* extract.

FIG. 46D is a perspective diagram of another embodiment of a packaged frozen ice pop of *Cannabis* juice purée with added decarboxylated high concentrate *Cannabis* extract and non-decarboxylated high concentrate *Cannabis* extract. In the example of FIG. 46D, the packaged frozen ice pop of *Cannabis* juice purée has 75 mg of non-decarboxylated cannabinoids from raw *Cannabis* plant, 310 mg of decarboxylated cannabinoids from decarboxylated high concentrate *Cannabis* extract, and 1,500 mg of non-decarboxylated cannabinoids from non-decarboxylated high concentrate *Cannabis* extract.

FIG. 47 is a diagram of a user 635 consuming the packaged frozen ice pop of *Cannabis* juice purée 632/634. The user 635 opens the top of the container 622 thereby forming an opening 623. The frozen ice pop of *Cannabis* juice purée 636 passes through the opening for the user 635 to consume. In this example the opening 623 is resealable such that the user 635 can consume a portion of the

29

packaged frozen ice pop of *Cannabis* juice purée 632/634, reseal the top, and store the partially consumed packaged frozen ice pop of *Cannabis* juice purée 632/634 in a freezer for future consumption.

FIG. 48 is a diagram of a side view of the packaged frozen ice pop of *Cannabis* juice purée 632/634. The container 622 has an upper extent 637, a lower extent 638, a first side extent 639, and a second side extent 640. The frozen ice pop of *Cannabis* juice purée 636 is disposed within an inner portion 641. The frozen ice pop of *Cannabis* juice purée 636 directly contacts the inner portion 641 of container 622. No packaging material is disposed between the frozen ice pop of *Cannabis* juice purée 636 and the inner portion 641 of container 622. The packaged frozen ice pop of *Cannabis* juice purée 632/634 includes a resealable mechanism 642. The resealable mechanism 642 is similar to the resealable mechanisms provided in zipper storage bags or slider storage bags.

In this example, the packaged frozen ice pop of *Cannabis* juice purée 632/634 is between 1.0 to 2.0 inches wide (dimension of upper and lower extents 637/638) and between 7.0 and 9.0 inches long (dimension of side extents 639/640). Each of the first and second side extents 639 and 640 is at least three times a length of each of the upper and lower extents 637 and 638. The upper extent 637 extends parallel to the lower extent 638. The first side extent 639 extends parallel to the second side extents 640. The packaged frozen ice pop of *Cannabis* juice purée 632/634 has a rectangular shaped when viewed from the side perspective of FIG. 48.

FIG. 49 is a diagram of a top view of the packaged frozen ice pop of *Cannabis* juice purée 632/634. The packaged frozen ice pop of *Cannabis* juice purée 632/634 has an edge portion 643 having a first thickness 644. The packaged frozen ice pop of *Cannabis* juice purée 632/634 has a center portion 645 having a second thickness 646. The second thickness 646 is at least ten times the first thickness 644. The packaged frozen ice pop of *Cannabis* juice purée 632/634 has an oval shape when viewed from the top perspective of FIG. 49.

FIG. 50 is a diagram of a side view of another embodiment of a packaged frozen ice pop of *Cannabis* juice purée 650 having a container 651 that is not resealable. A frozen ice pop of *Cannabis* juice purée 652 is disposed within container 651. The packaged frozen ice pop of *Cannabis* juice purée 650 has a top portion 653 that does not include a resealable mechanism as in the packaged frozen ice pop of *Cannabis* juice purée 632/634 shown in FIG. 47. A user tears the top portion 653 of the container 651 to provide an opening so that the frozen ice pop of *Cannabis* juice purée 652 passes through the opening and is consumed by the user.

FIG. 51 is a flowchart of a method 700 to package a plurality of packaged frozen ice pops of *Cannabis* juice purée. In a first step (step 710), a plurality of packaged frozen ice pops of *Cannabis* juice purée is packaged into a container. For example, in FIG. 52, a plurality of packaged frozen ice pops of *Cannabis* juice purée 711 is placed inside a package 712. The plurality of packaged frozen ice pops of *Cannabis* juice purée 711 is disposed within the package 712. An amount of instructions is included with the package. In one example, the amount of instructions is provided on a label 713 affixed or printed directly onto the package and instructs the user on the types and amounts of cannabinoids present in each frozen ice pop of *Cannabis* juice purée. In another example, a label is also printed or affixed onto each of the plurality of packaged frozen ice pops of *Cannabis* juice purée 711. The amount of instructions may also

30

instruct a user on how to consume the frozen ice pop of *Cannabis* juice purée as well as provide information regarding health benefits and possible side effects.

FIG. 53 is a flowchart of a method 800 to store packages comprising a plurality of packaged frozen ice pops of *Cannabis* juice purée. For example, in a first step (step 810), a plurality of packaged frozen ice pops of *Cannabis* juice purée are stored at a temperature that prevents the packaged frozen ice pops of *Cannabis* juice purée from melting. For example, in FIG. 54, a plurality of packages 811 is stored in a freezer 812. The packages 811 are stored by arranging each package in a compartment of the freezer 812. The stored packages 813 are stored until they are to be distributed to dispensaries or users.

FIG. 55 is a flowchart of a method 900 in accordance with a fourth embodiment. The method 900 is a method of manufacturing and packaging a *Cannabis* juice purée. In one specific embodiment, the packaged *Cannabis* juice purée has an amount of non-decarboxylated cannabinoids and is non-psychoactive. In another specific embodiment, the packaged *Cannabis* juice purée has an amount of non-decarboxylated cannabinoids and an amount of decarboxylated cannabinoids. The amount of decarboxylated cannabinoids in each packaged *Cannabis* juice purée is at least 5 mg. The packaged *Cannabis* juice purée is not frozen and can be stored at room temperature or in a refrigerator until opened.

In a first step (step 910), a *Cannabis* juice purée is formed. To form a packaged *Cannabis* juice purée that is non-psychoactive, raw *Cannabis* material having an amount of non-decarboxylated cannabinoids is collected. For example, in FIG. 2, raw *Cannabis* material 112 is collected by trimming leaves 113 from the *Cannabis* plant 111, and in FIG. 3, the raw *Cannabis* material 112 is blended in a blender 121 with water 122 and a thickening agent 123 to form a *Cannabis* juice purée.

To form a packaged *Cannabis* juice purée that is psychoactive, a portion of the collected raw *Cannabis* material is heated. For example, in FIG. 13, raw *Cannabis* material 211 is collected from a first *Cannabis* plant 212 and a second *Cannabis* plant 213. A first portion 214 of the raw *Cannabis* material 211 is obtained from the first *Cannabis* plant 212. Next, the first portion of raw *Cannabis* material 214 is blended in a blender 221 with water 222 and a thickening agent 223 to form a non-decarboxylated *Cannabis* juice purée as shown in FIG. 14. Next, a second portion 216 of the raw *Cannabis* material 211 is obtained from the second *Cannabis* plant 213 as shown in FIG. 13. Next, the second portion of collected raw *Cannabis* material is heated, as shown for example in FIG. 15. The non-decarboxylated *Cannabis* juice purée is combined with the decarboxylated *Cannabis* juice purée prior to packaging.

In both the non-decarboxylated embodiment and the decarboxylated embodiment of the packaged *Cannabis* juice purée, a sweetening agent or flavoring agent is optionally added to the *Cannabis* juice purée. The sweetening agent is selected from the group consisting of honey, *stevia*, fruit juice, sugar, corn syrup, or any other type of food grade sweetener. The sweetening agent provides a cannabinoid juice blend that is more palatable than if the sweetening agent were not included. Flavoring agents are optionally added to the packaged *Cannabis* juice purée, such as fruit flavor, spice (apple, cherry, mint, tart, etc.), or any other type of food grade flavoring. Fruit juice, fruit, or vegetable material may also be added, such as blueberries, blueberry juice, carrots, or carrot juice.

In a second step (step 920), the *Cannabis* juice purée is deposited into a container. In one example, the container is

a cylindrical shaped structure having a lid. The container **921** is formed from a glass material, a plastic material, or a paper-based material. For example, in FIG. **56**, the *Cannabis* juice purée **921** is deposited into a container **922** through opening **923**.

In a third step (step **930**), the container having the *Cannabis* juice purée is packaged without heating the *Cannabis* juice purée. For example, in FIG. **57**, the *Cannabis* juice purée **921** is packaged using high pressure processing (HPP) without applying heat thereby preventing the *Cannabis* juice purée **921** from decarboxylating during the packaging process. Conventional pasteurization methods, on the other hand, apply heat which may undesirably decarboxylate the cannabinoids in the *Cannabis* juice purée.

During the HPP process, the *Cannabis* juice purée **921** is loaded into a high pressure chamber filled with pressure transmitting fluid. In one example, the pressure transmitting fluid is water. The generated pressure is applied to the *Cannabis* juice purée **921**. A lid **924** is used to seal the opening **923** of the container **922**. For additional information on HPP, see: (1) U.S. Pat. No. 9,277,763, entitled "Bio-preservation Methods For Beverages And Other Foods", filed Jun. 23, 2014 by Beckman et al.; (2) U.S. Pat. No. 7,906,160, entitled "Protein beverage and method of making the same", filed Mar. 7, 2007 by Sherwood et al.; and (3) U.S. Pat. No. 5,232,726, entitled "Ultra-high pressure homogenization of unpasteurized juice", filed Oct. 8, 1992 by Clark et al. (the subject matter of these patent documents is incorporated herein in its entirety).

FIG. **58A** is a perspective diagram of the packaged *Cannabis* juice purée with only non-decarboxylated cannabinoids. The packaged *Cannabis* juice purée has 120 mg of THCa and 180 mg of CBDa. The packaged *Cannabis* juice purée is formed by carrying out the steps set forth in method **900** such that the *Cannabis* juice purée in the first step (step **910**) has only raw, blended *Cannabis* material. None of the collected *Cannabis* material is heated. The packaged *Cannabis* juice purée does not include any decarboxylated cannabinoids and the packaged *Cannabis* juice purée is not psychoactive. In this example, the ratio of CBDa to THCa is 3:2. The amount of CBDa in each packaged *Cannabis* juice purée is greater than the amount of THCa, and the amount of CBD in each packaged *Cannabis* juice purée is greater than the amount of THC. In other embodiments, each packaged *Cannabis* juice purée has ratio of CBDa to THCa taken from the group consisting of: 2 CBDa to 1 THCa, 1 CBDa to 1 THCa, 1 CBDa to 2 THCa, 1 CBDa to 3 THCa, 3 CBDa to 1 THCa, 0 CBDa to 1 THCa (no CBDa, only THCa), and 1 CBDa to 0 THCa (no THCa, only CBDa). The packaged *Cannabis* juice purée may be made to include or exclude non-cannabinoid components of the *Cannabis* plant that include terpenes, fatty acids, aminoacids, enzymes, vitamins, minerals, carotenoids, chlorophyll, flavonoids, and dietary fibers. Non-decarboxylated high concentrate *Cannabis* extract may also be added to the packaged *Cannabis* juice purée to achieve high concentrations of non-decarboxylated cannabinoids.

FIG. **58B** is a perspective diagram of another embodiment of a packaged *Cannabis* juice purée with added non-decarboxylated high concentrate *Cannabis* extract. In the example of FIG. **58B**, the packaged *Cannabis* juice purée has 300 mg of non-decarboxylated cannabinoids from raw *Cannabis* plant and 6,000 mg of non-decarboxylated cannabinoids from non-decarboxylated high concentrate *Cannabis* extract.

FIG. **59A** is a perspective diagram of a packaged *Cannabis* juice purée with added decarboxylated cannabinoids.

The packaged frozen ice pop of *Cannabis* juice purée **634** is formed by carrying out the steps set forth in method **900** such that the *Cannabis* juice purée in the first step (step **910**) has raw, blended *Cannabis* material in addition to decarboxylated *Cannabis* infusion. The packaged *Cannabis* juice purée includes non-decarboxylated cannabinoids and decarboxylated cannabinoids. In this example, packaged *Cannabis* juice purée has 300 mg of non-decarboxylated cannabinoids from raw *Cannabis* plant and 280 mg of decarboxylated cannabinoids from decarboxylated *Cannabis* infusion.

FIG. **59B** is a perspective diagram of another embodiment of a packaged *Cannabis* juice purée with added decarboxylated *Cannabis* infusion and non-decarboxylated high concentrate *Cannabis* extract. In the example of FIG. **59B**, the packaged *Cannabis* juice purée has 300 mg of non-decarboxylated cannabinoids from raw *Cannabis* plant, 280 mg of decarboxylated cannabinoids from decarboxylated *Cannabis* infusion, and 6,000 mg of non-decarboxylated cannabinoids from non-decarboxylated high concentrate *Cannabis* extract.

FIG. **59C** is a perspective diagram of another embodiment of a packaged *Cannabis* juice purée with added decarboxylated high concentrate *Cannabis* extract. In the example of FIG. **59C**, the packaged *Cannabis* juice purée has 300 mg of non-decarboxylated cannabinoids from raw *Cannabis* plant and 310 mg of decarboxylated cannabinoids from decarboxylated high concentrate *Cannabis* extract.

FIG. **59D** is a perspective diagram of another embodiment of a packaged *Cannabis* juice purée with added decarboxylated high concentrate *Cannabis* extract and non-decarboxylated high concentrate *Cannabis* extract. In the example of FIG. **59D**, the packaged *Cannabis* juice purée has 300 mg of non-decarboxylated cannabinoids from raw *Cannabis* plant, 310 mg of decarboxylated cannabinoids from decarboxylated high concentrate *Cannabis* extract, and 6,000 mg of non-decarboxylated cannabinoids from non-decarboxylated high concentrate *Cannabis* extract.

FIG. **60** is a flowchart of a method **1000** to store packaged containers having a *Cannabis* juice purée. In a first step (step **1010**), packaged containers having a *Cannabis* juice purée are stored. For example, in FIG. **61**, containers **1011** each having a *Cannabis* juice purée are stored on a shelf **1012**. The shelf **1012** may be part of a retail-store, a dispensary, a storage facility, or a transport vehicle.

FIG. **62** is a table **1100** that shows the therapeutic benefits of various types of cannabinoids. The amount and type of cannabinoid present in each of the embodiments can vary depending on the specific therapeutic benefits being targeted. The *Cannabis* juice purée used in the various embodiments has at least one type of cannabinoid listed in table **1100**.

Although certain specific embodiments are described above for instructional purposes, the teachings of this patent document have general applicability and are not limited to the specific embodiments described above. For example, in addition to THC and CBD, other combinations of cannabinoids can be employed. For example, CBG is another cannabinoid that can be present in certain strains of *Cannabis*. Non-decarboxylated CBG (CBGa) and decarboxylated CBG (CBG) can be used in forming the *Cannabis* juice purée. In addition, CBN is another cannabinoid that can be present in certain strains of *Cannabis*. Non-decarboxylated CBN (CBNa) and decarboxylated CBN (CBN) can be used in forming the *Cannabis* juice purée. In addition, other *Cannabis* strains with various terpene profiles can be added to the *Cannabis* juice purée in the various embodiments.

Accordingly, various modifications, adaptations, and combinations of various features of the described embodiments can be practiced without departing from the scope of the invention as set forth in the claims.

What is claimed is:

1. A method comprising:
forming a *Cannabis* juice purée, wherein the *Cannabis* juice purée is formed by blending *Cannabis* plant material of a *Cannabis* plant, wherein all of the *Cannabis* plant material is converted into the *Cannabis* juice purée, wherein the *Cannabis* juice purée comprises non-decarboxylated cannabinoids that include cannabidiolic acid (CBDA) and tetrahydrocannabinolic acid (THCA), wherein the CBDA and the THCA are present in accordance with a ratio, and wherein the ratio is taken from the group consisting of: 3 CBDA:1 THCA, 3 CBDA:2 THCA, 2 CBDA:1 THCA, 4 CBDA:1 THCA, 20 CBDA:1 THCA, 30 CBDA:1 THCA, 1 CBDA:1 THCA, 1 CBDA:4 THCA, 1 CBDA:2 THCA, 2 CBDA:3 THCA, 1 CBDA:3 THCA, 1 CBDA:20 THCA, and 1 CBDA:30 THCA;
depositing the *Cannabis* juice purée into a container; and packaging the container with the *Cannabis* juice purée.
2. The method of claim 1, wherein the packaging involves using high pressure processing (HPP) to package the container.
3. The method of claim 1, wherein the container into which the *Cannabis* juice purée is deposited is a cylindrical container having a lid.
4. The method of claim 1, wherein the *Cannabis* plant material includes at least one non-cannabinoid component taken from the group consisting of: terpenes, fatty acids, aminoacids, enzymes, vitamins, minerals, carotenoids, chlorophyll, flavonoids, and dietary fibers.
5. The method of claim 1, wherein the container includes at least one of decarboxylated high concentrate *Cannabis* extract, non-decarboxylated high concentrate *Cannabis* extract, decarboxylated *Cannabis* infusion, or heated *Cannabis* material.
6. A method comprising:
forming a *Cannabis* juice purée by blending *Cannabis* plant material of a *Cannabis* plant, wherein all of the *Cannabis* plant material is converted into the *Cannabis* juice purée, wherein the *Cannabis* juice purée comprises non-decarboxylated cannabinoids that include cannabidiolic acid (CBDA) and tetrahydrocannabinolic acid (THCA), wherein the CBDA and the THCA are present in accordance with a ratio, and wherein the ratio is taken from the group consisting of: 3 CBDA:1 THCA, 3 CBDA:2 THCA, 2 CBDA:1 THCA, 4 CBDA:1 THCA, 20 CBDA:1 THCA, 30 CBDA:1 THCA, 1 CBDA:1 THCA, 1 CBDA:4 THCA, 1 CBDA:2 THCA, 2 CBDA:3 THCA, 1 CBDA:3 THCA, 1 CBDA:20 THCA, and 1 CBDA:30 THCA;
depositing the *Cannabis* juice purée into a container; and performing high pressure processing (HPP) on the *Cannabis* juice purée within the container thereby obtaining a packaged *Cannabis* juice purée.
7. The method of claim 6, wherein the *Cannabis* plant material includes at least one component taken from the group consisting of: terpenes, fatty acids, aminoacids, enzymes, vitamins, minerals, carotenoids, chlorophyll, flavonoids, and dietary fibers.
8. The method of claim 6, wherein the container includes at least one of decarboxylated high concentrate *Cannabis*

extract, non-decarboxylated high concentrate *Cannabis* extract, decarboxylated *Cannabis* infusion, or heated *Cannabis* material.

9. The method of claim 1, wherein the *Cannabis* juice purée also includes at least one cannabinoid taken from the group consisting of: cannabigerolic acid (CBGA), cannabigerovarin acid (CBGVA), tetrahydrocannabivarin carboxylic acid (THCVA), cannabidivarin acid (CBDVA), cannabichromenic acid (CBCA), cannabichromevarinic acid (CBCVA), tetrahydrocannabinol (THC), tetrahydrocannabivarin (THCV), tetrahydrocannabivarin acid (THVA), cannabidiol (CBD), cannabidivarin (CBDV), cannabichromene (CBC), cannabichromevarin (CBCV), cannabigerol (CBG), cannabigerovarin (CBGV), cannabinolic acid (CBNA), cannabigerovarinic acid (CBNVA), cannabinol (CBN), cannabicyclol (CBL), and cannabicyclol acid (CBLA).
10. The method of claim 6, wherein the *Cannabis* juice purée also includes at least one cannabinoid taken from the group consisting of: cannabigerolic acid (CBGA), cannabigerovarin acid (CBGVA), tetrahydrocannabivarin carboxylic acid (THCVA), cannabidivarin acid (CBDVA), cannabichromenic acid (CBCA), cannabichromevarinic acid (CBCVA), tetrahydrocannabinol (THC), tetrahydrocannabivarin (THCV), tetrahydrocannabivarin acid (THVA), cannabidiol (CBD), cannabidivarin (CBDV), cannabichromene (CBC), cannabichromevarin (CBCV), cannabigerol (CBG), cannabigerovarin (CBGV), cannabinolic acid (CBNA), cannabigerovarinic acid (CBNVA), cannabinol (CBN), cannabicyclol (CBL), and cannabicyclol acid (CBLA).
11. A method comprising:
forming a *Cannabis* juice purée, wherein the *Cannabis* juice purée is formed by blending *Cannabis* plant material of a *Cannabis* plant, wherein all of the *Cannabis* plant material is converted into the *Cannabis* juice purée, wherein the *Cannabis* juice purée comprises non-decarboxylated cannabinoids that include cannabidiolic acid (CBDA) and tetrahydrocannabinolic acid (THCA), wherein the CBDA and the THCA are present in accordance with a ratio, and wherein the ratio is taken from the group consisting of: 3 CBDA:1 THCA, 3 CBDA:2 THCA, 2 CBDA:1 THCA, 4 CBDA:1 THCA, 20 CBDA:1 THCA, 30 CBDA:1 THCA, 1 CBDA:1 THCA, 1 CBDA:4 THCA, 1 CBDA:2 THCA, 2 CBDA:3 THCA, 1 CBDA:3 THCA, 1 CBDA:20 THCA, and 1 CBDA:30 THCA; and using high pressure processing (HPP) to package the *Cannabis* juice purée into a container.
12. The method of claim 11, wherein the container has a removable lid.
13. The method of claim 11, wherein the *Cannabis* plant material includes at least one non-cannabinoid component taken from the group consisting of: terpenes, fatty acids, amino acids, enzymes, vitamins, minerals, carotenoids, chlorophyll, flavonoids, and dietary fibers.
14. The method of claim 11, further comprising:
adding at least one of decarboxylated high concentrate *Cannabis* extract, non-decarboxylated high concentrate *Cannabis* extract, decarboxylated *Cannabis* infusion, or heated *Cannabis* material to the *Cannabis* juice purée.
15. The method of claim 11, wherein the *Cannabis* juice purée additionally includes at least one cannabinoid taken from the group consisting of: cannabigerolic acid (CBGA), cannabigerovarin acid (CBGVA), tetrahydrocannabivarin carboxylic acid (THCVA), cannabidivarin acid (CBDVA), cannabichromenic acid (CBCA), cannabichromevarinic acid (CBCVA), tetrahydrocannabinol (THC), tetrahydrocannabi-

varin (THCV), tetrahydrocannabivarin acid (THVA), cannabidiol (CBD), cannabidivarin (CBDV), cannabichromene (CBC), cannabichromevarin (CBCV), cannabigerol (CBG), cannabigerovarin (CBGV), cannabinolic acid (CBNA), cannabigerovarinic acid (CBNVA), cannabinol (CBN), cannabicyclol (CBL), and cannabicyclol acid (CBLA).

* * * * *