



(51) International Patent Classification:

E03C 1/22 (2006.01) E03B 1/04 (2006.01)  
E03C 1/23 (2006.01) E03C 1/12 (2006.01)

(21) International Application Number:

PCT/IB2016/057053

(22) International Filing Date:

23 November 2016 (23.11.2016)

(25) Filing Language:

Italian

(26) Publication Language:

English

(30) Priority Data:

102015000077422  
26 November 2015 (26.11.2015) IT

(71) Applicant: **WATER POWERED S.R.L.** [IT/IT]; Via delle Repubbliche Marinare, 124/128, 80147 Napoli (IT).

(72) Inventor: **SODO, Diego**; c/o WATER POWERED S.r.l., Via delle Repubbliche Marinare, 124/128, 80147 Napoli (IT).

(74) Agents: **GIUGNI, Diego** et al.; Via della Colonna 35, 33170 Pordenone (IT).

(81) Designated States (unless otherwise indicated, for every kind of national protection available): AE, AG, AL, AM, AO, AT, AU, AZ, BA, BB, BG, BH, BN, BR, BW, BY, BZ, CA, CH, CL, CN, CO, CR, CU, CZ, DE, DJ, DK, DM, DO, DZ, EC, EE, EG, ES, FI, GB, GD, GE, GH, GM, GT, HN, HR, HU, ID, IL, IN, IR, IS, JP, KE, KG, KN, KP, KR, KW, KZ, LA, LC, LK, LR, LS, LU, LY, MA, MD, ME, MG, MK, MN, MW, MX, MY, MZ, NA, NG, NI, NO, NZ, OM, PA, PE, PG, PH, PL, PT, QA, RO, RS, RU, RW, SA, SC, SD, SE, SG, SK, SL, SM, ST, SV, SY, TH, TJ, TM, TN, TR, TT, TZ, UA, UG, US, UZ, VC, VN, ZA, ZM, ZW.

(84) Designated States (unless otherwise indicated, for every kind of regional protection available): ARIPO (BW, GH, GM, KE, LR, LS, MW, MZ, NA, RW, SD, SL, ST, SZ, TZ, UG, ZM, ZW), Eurasian (AM, AZ, BY, KG, KZ, RU, TJ, TM), European (AL, AT, BE, BG, CH, CY, CZ, DE, DK, EE, ES, FI, FR, GB, GR, HR, HU, IE, IS, IT, LT, LU,

[Continued on next page]

(54) Title: MULTIPLE DRAINING SYSTEM FOR SINKS OR BASINS

(57) Abstract: The present invention relates to a multiple draining system (1;100-121) for sinks or wash-basins mainly for domestic use. In particular, the invention is relative to a draining system provided with a simple and reliable construction which allows to recover wastewater from sinks or basins when it is desired to use it for further processing or other direct uses. The system comprises means for diverting (5, 32-33) wastewater flow alternatively to a sewage system and to a recovery system, by means of a control (4;13; L; 13a; 611; 692) positioned above the level of the bottom (A) of the basin for collecting water.

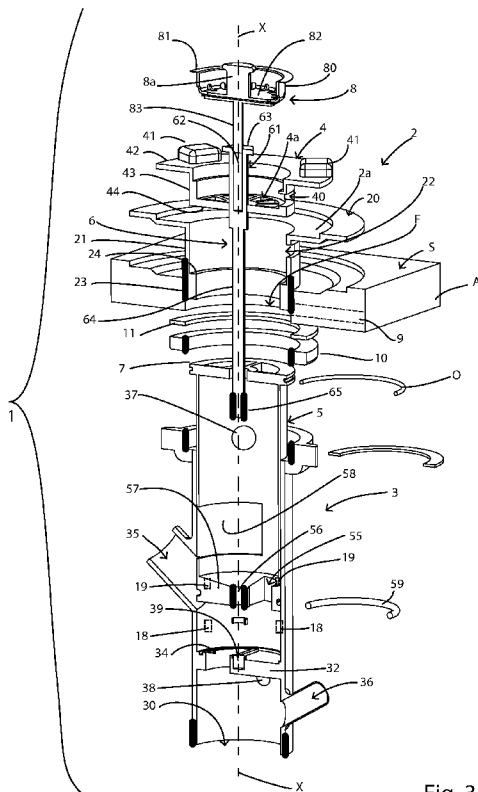

Fig. 3

WO 2017/089964 A1

LV, MC, MK, MT, NL, NO, PL, PT, RO, RS, SE, SI, SK, **Published:**  
SM, TR), OAPI (BF, BJ, CF, CG, CI, CM, GA, GN, GQ, — *with international search report (Art. 21(3))*  
GW, KM, ML, MR, NE, SN, TD, TG).

## MULTIPLE DRAINING SYSTEM FOR SINKS OR BASINS

### DESCRIPTION

#### TECHNICAL FIELD OF THE INVENTION

**[001]** The present invention relates to a multiple draining system for sinks or basins, mainly for sanitary domestic use. In particular the invention is relative to a draining system provided with a simple and reliable construction that allows to recover wastewater from sinks or basins when it is desired to use such water for further processing or other direct uses.

#### PRIOR ART TECHNIQUE

**[002]** At present the discharge of water for civil use, from basins, sinks or other systems mainly for domestic use, containing food or detergents in greater or lesser amounts, takes place through a collecting drain. The drain is fixed on the bottom of a collecting basin (for example wash-basin or sink) usually by means of a ring nut, underneath the bottom, which screwed on the drain with the insertion of a gasket, making it integral to such bottom, as shown in fig. 1. Another very used system is that shown in fig. 2 wherein a first upper element of the drain is fixed to the bottom of the basin by means of a central fixing pin, which being screwed to the lower element of the drain, placed under said basin bottom, joins integrally said first and said second element thus forming the drain body.

**[003]** In both solutions, to the underneath end portion of the drain there are connected waste pipes, usually made of plastic, either screwed to that portion or through a pressure gaskets. The pipes may or may not be siphoned and have the task of carrying wastewater to collection and separation tanks and from these to the sewage system.

**[004]** The drains are made of materials of various types: metal, plastic or both metal and plastic.

**[005]** In order to shut the drain various systems are used: with time, the usual plug has been replaced by the traditional filter plug or basket which is at present the most used one in modern kitchens and which, at the same time, acts as a plug and a filter for the drain (fig. 2) or shutting systems having a back lever returning or by means of a rod operated by a knob.

**[0006]** The wise user, especially in those countries where water is very scarce and precious, realizes that a great quantity of water is discharged into the sewage system which instead could be well channelled for other uses.

**[0007]** To this purpose a lot of systems have been realized for recovering “grey water” from the bathroom such as that from the washbasin, from the shower or from the bathtub, as well as rainwater, mainly to be recycled in the W.C. as the W.C. flush is where water is used the most.

**[0008]** Alternatively, a great number of systems for recovering water have been realized through the treatment of the same W.C. wastewater or through systems for recovering grey water through degreasing or phytodepuration, that however have high costs and a set of dimensioning problems not always solvable concerning phytodepuration.

**[0009]** Just as much attention has not been given to recycling “clean” water from the kitchen or from the bathroom that in the everyday use all together became substantial for alternative uses. In fact, it frequently occurs that much of the water used in the domestic wastewater drainage circuit, wherefrom it is discharged into the sewage system, is not really contaminated by any element such as detergents or other pollutants or not biodegradable, in other words containing totally biodegradable detergents in use at present. Let’s consider when vegetables or fruits are cleaned or washed, when you wash your hands while cooking, the pasta or vegetables cooking water, or when dusty objects are washed. Again, washing continuously kitchen tools while cooking produces “dirty” water which is not really “dirty”, on the contrary it is absolutely useful for further uses and specifically for some domestic uses such as watering plants or the lawn.

**[0010]** In these cases, that water is therefore potentially suitable for recycling in natural ways, other than the mere W.C. flush.

**[0011]** Sometimes a big pot or other container is put in the sink when it is desired to collect the water used and then recycle it directly watering plants. Such system is certainly not very convenient and cannot be used immediately. Therefore, as in the above said cases, the water quantity usually used up/discharged in sinks cannot be recycled any more or at the very least not very easily.

**[0012]** A more practical solution, in order to achieve such recycling possibility, consists in realizing a double draining circuit controlled by a diverter under the basin. In this way, with two systems, one for the sewage and one for recovering, the recovered water is directed to the garden or to a storage container so as to be subsequently used for gardening or other suitable use. Such system is undoubtedly useful, effective to the

purpose, but it certainly has some considerable drawbacks and complexities for the user.

**[0013]** First of all, whenever the user wants to recycle even a small quantity of water, he must bend down towards the front part of the cabinet which is usually fitted under the wash-basin, open its wings, operate the gate acting as a diverter, close the cabinet, and do the opposite to go back to the sewage system.

**[0014]** Such "D.I.Y." system shows a lot of inefficiencies and drawbacks: it is not immediate, it is necessary to bend twice in order to operate it in one way and then go back to the previous condition (opening/closing cycle); it does not allow the user to see if the diverter is in the sewage state or in the recovery state; it takes up precious room under the wash-basin; it is rather expensive, even for the less expensive drains, for the number of items to buy and/or to adjust. Also the possibility of using remote control systems, such as those on the market, involve a series of adjustments in order to be applied to the wash-basin. These solutions prove to be complex solutions, since anyhow, it is necessary to modify and/or to make a hole in the cabinet whereon the wash-basin rests as well as to make adjustments that many users do not like.

**[0015]** Furthermore, the use of the products present on the market would result in systems having considerable dimensions. In practice, it derives that recovery systems are rarely realized in sinks for all the above said reasons of usage drawbacks, of lack of immediate visualization of the sewage or recovery systems, of appearance, of costs.

**[0016]** For example, the patent application GB 2430444 describes a grey water draining system comprising an inlet for grey water (sink drain), first and second outlets for discharging grey water, the first outlet being connected to a draining system (to sewage) and the second outlet being connected to a recovery system, a valve for selectively directing water to the first outlet or to the second outlet, the valve being positioned between the inlet and the first outlet or the second outlet, wherein the valve is activatable between first and second positions connecting alternatively the inlet to the first outlet and the inlet to the second outlet. It is to note that the valve comprises an *en bloc* sleeve and is operated by rotating the plug for closing the inlet (sink drain). Therefore, the plug and the valve are an *en bloc* piece which has to be completely made for that purpose, thus basically modifying the basic structure of a traditional system.

**[0017]** Patent application FR 3000508 describes a recuperator of domestic water comprising a three-way valve which intercepts the water waste pipe after the siphon and is composed of a cylinder activated by a remote control by means of a rod capable of

causing the cylinder to rotate by 90°. Through the rotation of the cylinder, water is directed straight to the sewage system or to a storage container wherein an electric pump, when activated, makes it possible to reuse the water for further purposes. This solution appears to be rather complex and encumbering and not applicable to traditional systems.

#### SUMMARY OF THE INVENTION

**[0018]** The technical problem at the basis of the present invention is therefore that of realizing a new device that inserted in a suitable draining system, that is in draining systems on the market which do not have any chokes or interruptions, when used, allows to overcome the above said drawbacks; just the opposite, it allows to realize, in the same spaces, a substantially different system having an appearance the same as those at present on the market and which allows to operate quickly, even for small quantities of water, being able to control visually the real operation of the activated draining system and even with a full sink it is possible to choose the type of draining system before activating its opening.

**[0019]** Such problem is solved by means of a multiple draining system according to various embodiments, starting from only one concept for all solutions: to make the drain, from just an element of interception and connection to the draining system, become only one system of interception and diversion of the draining with immediate control, either when the draining is open or closed being able to see the active draining function.

#### BRIEF DESCRIPTION OF DRAWINGS

**[0020]** Further characteristics and advantages of the multiple draining system of the invention will become more apparent from the following description of some embodiments by way of example only but not limited to with reference to the following figures, wherein:

- figure 1 is a schematic sectional lateral view of a drain for sinks in accordance with a first embodiment according to the prior art;
- figure 2 is a schematic sectional lateral view of a drain for sinks in accordance with a second embodiment according to the prior art;
- figure 3 is a schematic axonometric view in an exploded and sectional way of a double draining system for sinks according to a first embodiment of the present invention;
- figure 4 is a sectional lateral view of the double draining system of figure 3 assembled in a first usage condition;

- figure 5 is a sectional lateral view of the double draining system of figure 3 assembled in a second usage condition;
- figure 6 is an axonometric view of a rotating cylinder of diverting means of the draining system of figure 3;
- figure 7 is a sectional axonometric view of the cylinder with the relative upper portion of a drain in an assembled state;
- figure 8 is a schematic sectional lateral view of a waste pipe of the draining system of figure 3;
- figure 9 is an axonometric view of the waste pipe of figure 8;
- figure 10 is a schematic axonometric view in an exploded and sectional way of a double draining system for sinks according to a second embodiment of the present invention;
- figure 11A is a schematic lateral view, assembled and sectional, of the draining system of figure 10 in a first operating condition;
- figure 11B is a schematic lateral view, assembled and sectional, of the draining system of figure 10 in a second operating condition;
- figure 12 is a schematic lateral view, exploded and sectional, of a double draining system for sinks in accordance with a third embodiment of the invention;
- figure 13 is a schematic lateral view, exploded and sectional, of a double draining system for sinks in accordance with a fourth embodiment of the present invention, and of one of its particulars;
- figure 14 is a sectional schematic lateral view of a double draining system for sinks in accordance with a fifth embodiment of the invention;
- figure 15 is a top plan view of a drain of the system according to the invention, in accordance with an embodiment variant;
- figure 16 is a sectional schematic lateral view of a double draining system for sinks in accordance with a sixth embodiment of the invention;
- figure 17A is a schematic lateral exploded view of a double draining system for sinks in accordance with a seventh embodiment of the invention;
- figure 17B is a lateral view of the system of figure 17A in an assembled state;
- figure 17C is a sectional top plan view along the line B-B of the system of figure 17B,
- figure 17D is a sectional lateral view along the line A-A of the system of figure 17B;

- figure 18 is a schematic lateral exploded view of a double draining system for sinks in accordance with an eighth embodiment of the invention,
- figure 19A is a schematic lateral exploded view of a double draining system for sinks in accordance with a ninth embodiment of the invention;
- figure 19B is a lateral view of the system of figure 19A in an assembled state;
- figure 19C is a sectional top plan view along the line B-B of the system of figure 19B;
- figure 20 is a schematic lateral exploded view of a multiple draining system for sinks in accordance with a tenth embodiment of the invention;
- figure 21 is a schematic lateral exploded view of a multiple draining system for sinks in accordance with an eleventh embodiment of the invention;
- figure 22 is a schematic lateral exploded view of a multiple draining system for sinks in accordance with a twelfth embodiment of the invention;
- figure 23 is a schematic lateral exploded view of a double draining system for sinks in accordance with a thirteenth embodiment of the invention;
- figure 24A is a schematic lateral exploded view of a multiple draining system for sinks in accordance with a fourteenth embodiment of the invention;
- figure 24B is a top view of the system of figure 24A assembled in a first operating condition,
- figure 24C is a sectional lateral view along the line A-A of the system of figure 24B;
- figure 24D is a sectional view along the line B-B of the system of figure 24C;
- figure 24E is a sectional view along the line F-F of the system of figure 24C;
- figure 24F is a top view of the system of figure 24A assembled in a second operating condition;
- figure 24G is a sectional lateral view along the line C-C of the system of figure 24F;
- figure 24H is a sectional view along the line D-D of the system of figure 24G;
- figure 24I is a sectional view along the line G-G of the system of figure 24G;
- figure 25A is a lateral exploded view of a multiple draining system for sinks in accordance with a fifteenth embodiment of the invention;
- figure 25B is a top view of the system of figure 25A in an assembled state;
- figure 25C is a sectional lateral view along the line A-A of the system of figure 25A in an assembled state;



- figure 25D is a sectional lateral view along the line B-B of the system of figure 25C;
- figure 26A is a top axonometric exploded view of a multiple draining system for sinks in accordance with a sixteenth embodiment of the invention;
- figure 26B is a lateral assembled view of the system of figure 26A;
- figure 26C is a sectional lateral view along the line A-A of the system of figure 26B;
- figure 27 is a lateral exploded view of a multiple draining system for sinks in accordance with a seventeenth embodiment of the invention,
- figure 28 is a top exploded axonometric view of some components of the system of figure 27;
- figure 29A-29B are respectively a lateral view and a sectional view along the line B-B of figure 29A of a rotating cylinder of the flow diverting means of the system of figure 27;
- figure 30A-30B are respectively a lateral and a sectional view along the line C-C of figure 30A of a water waste pipe of the system of figure 27;
- figure 31A-31C are respectively top axonometric view, a lateral view and a bottom view of the first engaging means for the rotation of the rotating cylinder of figure 29;
- figure 32 is a top axonometric view of a grid of a plug with the first engaging means of figures 31A-31C;
- figures 33A-33C are respectively a top axonometric view, a lateral view and a top plan view of an element of a drain according to the system of figure 27;
- figures 34A and 34B are respectively a top view of the system of figure 27 in an assembled state and a sectional view along the line A-A of figure 34A;
- figure 35 is a top sectional axonometric view of the assembled system of figure 27, in a first operating condition;
- figure 36 is a view as in figure 35, wherein the system is in a second operating condition;
- figure 37 is a view as in figure 35, wherein the system is in a third operating condition;
- figure 38 is a lateral exploded view of a draining system according to an eighteenth embodiment;

- figure 39 is a top axonometric exploded view of some components of the system of figure 38;
- figures 40A-40D are respectively a top view, a lateral view, a bottom view and a sectional view along the line I-I of figure 40B of means for diverting the water flow of the system of figure 38;
- figures 41A-41D are respectively a top view, a lateral view, a bottom view and a sectional view along the line J-J of figure 41B of a first portion of the waste pipe of the water flow of the system of figure 38;
- figures 42A-42B are respectively a top view and a sectional view along a line F-F of figure 42A of a second portion of the waste pipe of the water flow of the system of figure 38;
- figures 43A and 43B are respectively a top view and a lateral sectional view along the line A-A of figure 43A of the system of figure 38 in an assembled state;
- figure 44 is a top sectional axonometric view of the system of figure 38 in an assembled state and in a first operating condition;
- figure 45 is a top sectional axonometric view of the system of figure 38 in an assembled state and in a second operating condition;
- figure 46 is a top sectional axonometric view of the system of figure 38 in an assembled state and in a third operating condition,
- figure 47 is a lateral exploded view of a draining system according to a nineteenth embodiment;
- figure 48 is an exploded axonometric view of some components of the system of figure 47;
- figure 49A-49B are respectively a top axonometric view and a bottom plan view of a first part of rotating elements of the system of figure 47;
- figure 50 is a top axonometric view of a second part of rotating elements of the system of figure 47;
- figure 51 is a lateral exploded view of a draining system according to a twentieth embodiment;
- figures 52A-52B are respectively a top axonometric view and a bottom view of means for diverting the water flow of the system of figure 51;
- figures 53A-53C are respectively a top axonometric view, a top plan view and a lateral sectional view along the line D-D of figure 53B of a portion of the waste pipe of the system of figure 51;

- figures 54A-54D are respectively a top axonometric view, a bottom view, a lateral view and a lateral sectional view along the line I-I of figure 54C of an element, for fixing the drain to the waste pipe;
- figure 55 is a sectional lateral view of the system of figure 51 in an assembled state showing an enlarged particular;
- figures 56A-56C are respectively an axonometric view of the section of figure 55 of the system in a first, second and third operating condition;
- figure 57 is a lateral exploded view of a draining system according to a twenty-first embodiment,
- figures 58A-58C are respectively a top plan view, a bottom view and a sectional view along the line D-D of figure 58A of a rotating element of the system of figure 57;
- figures 59A-59B are respectively a top plan view and a sectional view along the line C-C of figure 59A of a portion of the waste pipe of the system of figure 57;
- figure 60 is a top axonometric exploded view of the rotating element and of the portion of the pipe respectively of the figures 58 and 59 having a connecting element between said element and the portion;
- figures 61A and 61B are two top sectional axonometric views of the system of figure 57 in an assembled state respectively in a first and in a second operating condition;
- figure 62 is a lateral exploded view of a draining system according to a twenty-second embodiment;
- figure 63 is a top axonometric view of the system of figure 62 in an assembled state and in a longitudinal section, in a first operating condition;
- figure 64 is a top axonometric view of the system of figure 62 in an assembled state and in a longitudinal section, in a second operating condition;
- figure 65 is a lateral exploded view of a draining system in accordance with a twenty-third embodiment;
- figure 66 is a top axonometric view of the system of figure 65 in an assembled state and in a longitudinal section, in a first operating condition;
- figure 67 is a top axonometric view of the system of figure 65 in an assembled state and in a longitudinal section, in a second operating condition.

## DETAILED DESCRIPTION OF THE INVENTION

**[0021]** In figure 1 there is shown a first commercial solution having a threaded through drain B fixed on the upper surface S of a draining plane A or basin bottom by means of a ring nut D. In figure 2 there is shown a second commercial solution wherein a drain comprises an upper element G mounted on the upper surface S of the bottom A of the basin and a body H underneath said surface and fixed to the upper element G by means of a through pin I. A filter plug T is then provided to reversibly close the same drain.

**[0022]** The object of the present invention starts from the assumption of an immediate control, which is easily visualizable, cost effective and of easy maintenance, in order to select either the sewage system or the recovery system. The general principle is therefore the direct activation from the wash-basin.

**[0023]** In fact, as shown in figures from 3 to 67, the present invention relates to a multiple draining system 1, 100-121 for sinks or wash-basins generally for domestic use, comprising a drain 2, 70, 240 fixed on the inner surface S of the bottom A of a basin for collecting water in correspondence of its draining hole F, and a waste pipe 3, 300, 340, 345, 360, 370, 380, 480, 530, 590, 520, 522, 451, 131 of the basin water.

**[0024]** The waste pipe is a rectilinear pipe extending along an axis X-X, mutual to the drain axis, and is provided with the primary waste pipe 30 for the sewage system and with at least a secondary waste pipe 35 for the recovery system.

**[0025]** In particular, the multiple draining system is characterized in that it comprises means for diverting the wastewater flow from the basin which are selectively activatable so as to discharge water through said primary waste pipe 30 or through said secondary waste pipe 35, wherein said diverting means are accommodated inside said waste pipe and are activatable by means of a control positioned above the level of the bottom A of the basin.

**[0026]** The solution described in the appended figures from 3 to 6 depicts a first embodiment of the present invention.

**[0027]** In that solution, as shown, the perforated surface of the bottom A of the basin for collecting water, such as a wash-basin, sink or the like, accommodates a drain 2 which preferably has a circumferential groove 2a for bearing a flange of a command element 4. In its turn, the drain 2 comprises a first bearing portion 20 on the inner surface S of the bottom A of said basin and a second through engaging portion 21 with said draining hole F of the basin. Further, the second portion 21 is provided with an end 23 for a sealed connection with said waste pipe 3. The drain 2 has then a suitable outer thread (not shown) on the end 23 whereto a ring nut 10 shall be screwed for the subsequent

tightening to the basin A with the insertion of a gasket 11. Internally, the second portion 21 has an annular bearing step 24 for a rotating element 5 described later. In case, the drain 2 may also have lateral apertures 22 for collecting overflow water coming from an overflow pipe 9 of the basin A.

**[0028]** The command element 4 has an annular support flange 42 on said circumferential groove of the first portion 20 of the drain 2, which flange is provided with gripping elements 41 so as to activate the rotation of a rotating element or cylinder 5. Furthermore, from the flange 42 it extends a cylindrical wall 43 coaxial with the second portion 21 of the drain 2. The cylindrical wall 43 has a bottom 44 provided with radial apertures 4a for the water flow and a perforated central axial portion. Laterally, that wall may comprise apertures 40 for draining overflow water, coming from the overflow pipe 9 of the basin A, which cooperate with the above said apertures 22 of the drain 2. Said command element 4 is integrally connected with a rotating element or cylinder 5 underneath by means of a pin 6, preferably perforated, for the transmission of the rotation given by said control element; the whole is contained in the water waste pipe 3 of the basin. The command element 4 is then realized in female form or basket so as to fit the usual filter plugs 8 present on the market.

**[0029]** The filter plug 8, preferably as shown in figure 3, comprises a cup-like portion 80 whose aperture is defined by a flange 81 and whose bottom 82 is a perforated grid (holes not shown in figure) for filtering wastewater. At the centre of the bottom 82, raises a knob 8a for controlling the closing of the plug by locking together with the drain 2. In correspondence of the knob 8a, but from the outer surface of the bottom 82, it departs, in a straight way, an axis 83 for the engagement with the seat 62 of the pin 6 for the connection between the control element 4 and the rotating cylinder 5.

**[0030]** In particular, the pin 6 comprises a head 61 provided with a seat 62 for engaging a plug/basket 8 and of a protruding edge 63 for resting on the bottom 44 of the rotatable element 4. That head passes through the above said central hole of the rotatable element 4, and continues with an elongated portion 64 ending with an end 65 for the integral engagement with the rotating cylinder 5. In this configuration, the rotation given by the rotating element 4 by acting on the gripping elements 41 selectively activates the water flow towards either one or the other draining systems, as later described.

**[0031]** The above said means for diverting the flow of the water into a sewage pipe or into a recovery pipe are preferably constituted by a rotating element or cylinder 5 which is commanded by the above said command element 4. The rotating cylinder 5 is generally made up of one or more pieces integral one with the other which together with

the rotating element 4, with or without the pin 6, acts as a control and diverting system, easy to place in or to remove from the drain 2 for maintenance and cleaning.

**[0032]** In particular, as better shown in figures 6 and 7, the rotating cylinder 5 extends longitudinally along the axis X-X and has a first end 50 for the connection with the drain 2 and a second end 51 for the connection with the water waste pipe 3. The first end 50 carries a flange 7 for the purpose of centering and improving the solidity of the assembly formed by the control element 4 and the rotating cylinder 5. In fact, that flange rests on the step 24 of the second portion 21 of the drain 2. Furthermore, the first end 50 is axially perforated having a plurality of radial apertures 52 and a central aperture 53 for receiving the above said pin 6. An annular seat 54 can be formed in said flange so as to accommodate a seal O gasket (figure 3). The second end 51 is axially perforated as well. In particular, an aperture 55 in the form of a circle sector extends preferably for 180°, about a central hole 56 for the engagement with said second end 65 of the pin 6. As later described, that aperture 55 is for draining the water in the sink into the sewage system. The remaining portion 57 of the second end 51 of the rotating cylinder 5 is axially closed. Preferably, the outer circular edge of the second end 51 has a groove 58 (fig. 6) for accommodating a relative seal 59 (figure 3). Furthermore, the lateral wall of the rotating cylinder 5 in the proximity of said second end 51 has a window 58 that preferably extends for about half the circumference of the cylinder in the position axially opposed with respect to the aperture 55. Such window has the function of diverting the water in the sink towards the recovery pipe or secondary waste pipe, as later described.

**[0033]** The waste pipe 3, wherein there is coaxially accommodated the above said rotating cylinder 5, comprises a first end 31 provided with a flange 31A for a sealed connection with the end of the second portion 23 of the drain 2 (figures 8 and 9). In correspondence of a second end 32, the inner surface of the pipe 3 comprises resting elements 33 or first wall of a gate-like device, wherein said first wall has a first aperture 34 for the water flow which extends similarly to a circle sector about an axial resting seat 39 as a centering and rotation point of the pin 6. Preferably, the first aperture 34 extends for about half a circle, more preferably for an angle less than 170°/180°. Further, such pipe 3 has laterally apertures or outlets on the lateral wall. A secondary waste pipe 35 is formed between said first wall 33 and said flange 31A and is angled towards said flange 31A, so as to allow the recovery draining when the system is closed. A further pipe 36 is connected to the sink overflow and it shall always be underneath said first wall 33, that is between the free edge of the second end 32 and said first wall. In particular, said first pipe 35 and said further pipe 36 are positioned

diametrically opposed. Furthermore, the lateral wall of the rotating cylinder 5 comprises two second apertures 37 and 38 joined one to the other by a channel or by-pass pipe C (shown in figure 9) so as to serve as safety overflow in case the recovery system of the secondary waste pipe 35 is full or in case of a malfunctioning of the system.

**[0034]** Moreover, the rotation of the rotating cylinder 5 inside the waste pipe 3, operated by means of the action of the fingers of a hand on the gripping elements 41 of the command element 4, is controlled and limited by stop means 18 and 19, such as protrusions respectively of the inner surface of the waste pipe 3 and of the outer surface of the rotating cylinder 5.

**[0035]** Now hereinafter it will be explained how the draining system 1 previously described works.

**[0036]** As shown in figure 4, the fluids from the drain 2 will be directed to the sewage system when, acting by rotation on the control element 4 by means of the gripping means 41, the rotation given about the axis X-X is transferred to the rotating cylinder through the pin 6. Thus, the rotating element 5 places itself with the aperture 55 of the second end 51 overlapping the closed portion of the first wall 33 of the waste pipe 3. Therefore, it will axially prevent the water flow through the second end 32 of the waste pipe 3 and, consequently, the water from the drain 2 will be directed to the secondary waste pipe 35 thanks to the window 58 of the rotating cylinder 5 which is in communication with said secondary waste pipe 35, as shown by the arrow. Thus, it is possible to recover the water contained in the sink for various uses such as watering gardens or plants in pots.

**[0037]** Instead, by rotating the command element 4 into the opposite direction, the above said aperture 55 of the rotating element 5 will be axially overlapped to the first aperture 34 of the first wall 33 of the waste pipe 3, thus allowing the water flow axially through the second end 32 of the waste pipe 3 so as to reach the sewage system, as shown by the arrow of figure 5. At the same time, the window 58 of the lateral wall of the rotating cylinder 5 places itself against the closed lateral wall of the waste pipe 3, opposite the secondary waste pipe 35 for recovery of the water from the sink.

**[0038]** It is to keep in mind that the above said rotating operations in one direction and in the opposite direction are controlled by the control element 4 and the above said stop means 18,19 regulates the rotation width to make either the apertures or the outlets or the window overlap or not one with the other so as to divert the water from the sink into the sewage system or into the recovery system.

**[0039]** In figure 10 there is shown an embodiment variant of the previously described solution, having, as a closing system for the sewage system, instead of the overlapping of the two apertures, a snap system 100 fixed inside the waste pipe 300. The parts in common with the previous embodiment are referred to with the same reference number.

**[0040]** In this solution, the pipe 300 is generally the same as the waste pipe 3 previously described. In particular, its inner surface of the lateral wall comprises an annular thickening or narrowing 301. Inside the pipe there is inserted a system comprising a pin 600, completely similar to the pin 6 of the rotating mechanism previously described, which freely passes through a plug 8b similar to the above described plug 8 but suitably perforated. Such plug 8b is independently connected by means of said pin 600 with another plug 12 provided with a through thread 12b that allows the threaded control or the gripping element 13 to integrally connect with the commercial snap device 14 fixed on a seat 15 of the pipe 300. On the circumference of the plug 12 there is an O-ring 12a which acts in correspondence of the narrowing 301 of the lateral wall of the pipe 300 allowing alternatively the water to flow or not into the primary waste pipe 30 (figures 11a and 11b).

**[0041]** In other words, the second end 302 of the pipe 300 defining the waste pipe 30 comprises a plurality of radial holes 303 for the draining of the water along the axis X-X of the pipe directly into the sewage system, and a central seat for engaging a snap device 14 apt at controlling the positioning of a plug 12 for closing the water flow through said plurality of holes 303. Practically, by means of the gripping element 13 it is possible to operate on the pin 600 which in turn pushes or pulls the plug 12 on the snap device 14. When the plug 12 is activated, the gasket 12a is pressed in correspondence of the narrowing 301 of the pipe 300 to prevent the water from flowing into the primary waste pipe 30 and allow the water to flow into the secondary waste pipe 35 (figure 11a), on the contrary, when the plug 12 is not activated, that is moved towards the drain 2, the gasket moves away from the step 301 thus allowing the water to flow into the primary waste pipe 30 (figure 12b).

**[0042]** A position reader 16 protrudes from the gripping element 13 and is connected to the snap device by means of a return mechanism 17 (figure 10).

**[0043]** In figure 12, there is shown a system 101 where the selective closing of the primary waste pipe 30 is realized by means of a plug 12 that stops against a narrowing 301 of the waste pipe 3. The parts in common with the previous embodiment are referred to with the same reference number. In this case, the lifting/lowering mechanism of the plug 12 comprises an articulated pin (not shown) with a first end protruding from



the upper rim of the basin and a second end (shown by a dashed line in figure 12) connected with said plug by means of an articulated lever mechanism 7. In such configuration, the rotatable element 4, though shown in figure 12, is not necessary to the system, and the drain 2 can be any of those on the market. It is to note that the control pin 6, 600, previously described, is therefore replaced by the above said articulated pin and by the lever mechanism 7 which constitute a system completely similar to the one traditionally used for example in wash-basins of domestic bathrooms to open and close the wash-basin draining.

**[0044]** In figure 13, there is shown another embodiment of the invention wherein the system 102 comprises a lifting/lowering mechanism, that is the activation of the plug 12 that too comprises a pin 601 having a first end 602 provided with a gripping element consisting of a lever L having cam L1 rotatable on a plane vertical to the axis X-X of the waste pipe 3. By acting on the lever L the plug is alternatively pressed so as to close an axially perforated inner wall 330 of the pipe 3. Preferably, the plug 12 is a plastic disc having a central hole so as to be passed through by the second end 603 of the pin 601. Such second end ends with a plate 604 for thrusting the plug against the above said inner wall 330 so as to close its axial hole (figure 13).

**[0045]** In figures 14 and 16 there are shown two more embodiment variants of the invention, wherein the systems 103, 104 to intercept water in order to divert it for the recovery are operated acting directly on the filter plug 8. In such configuration, the filter plug is directly connected with the intercepting and diverting system, that is with the means for diverting the flow of wastewater; in such solution the filter plug carries out, at the same time, the three functions of plug, of opening and of closing the gate-like diverting means. A gripping element 13A, similar to the one previously described, is fixed to the end of an axial pin 660, while means for diverting the water flow are connected to the second end 661 of said pin. Said diverting means can be those previously described with reference to the gate-like device 55,57 and 33,34 (figure 14, system 103) or can be a ball valve V (figure 16, system 104) adapted to direct alternatively the water flow towards the primary waste pipe 30 or towards the secondary waste pipe 31 horizontally arranged on the same line orthogonal to the axis X-X of the waste pipe 3. It is to note that if the diverting means are of the gate-like type, the two perforated walls 33 and 57 described with reference to the first embodiment of figure 3 shall be inverted, that is the movable wall will face downward while the fixed wall will be above said moveable wall, that is the fixed wall towards the drain 2 and the movable wall towards the primary waste pipe 30.

**[0046]** Figure 15 is a top view of a drain body 24 connected with the underneath portion (not shown) of the drain 2 by means of two pins adapted to engage two corresponding through curved slots 25 formed diametrically opposed on said drain body.

**[0047]** In figures 17A-17D there is shown another embodiment. The draining system 105 comprises a drain 200 provided with a first portion 201 for fixing on the bottom of the sink or wash-basin and a second portion 202 adapted to protrude from the lower or outer surface of the bottom of said sink or wash-basin so as to connect itself with a watertight seal, a cylindrical water waste pipe 340. The pipe 340 extends about a rectilinear axis X-X and is provided with a primary waste pipe 30 for the sewage system and a secondary waste pipe 35 for the recovery system. Means for diverting the wastewater flow are accommodated inside said waste pipe 340 and are selectively activatable so as to discharge water through said primary waste pipe or said secondary waste pipe. Said means are activatable by means of a control placed above the level of the basin bottom of the sink or of the wash-basin.

**[0048]** In particular, the first portion 201 for fixing the drain 200 consists of an externally threaded and flanged ring nut adapted to be inserted into the hole of the basin bottom (not shown) with the flange resting on a portion about said hole and with the threaded part protruding from the outer surface of the hole. The second portion 202 comprises a flanged ring nut 203 having the inner surface provided with counter threading for the screw-like engagement with the first portion 201 so that the flanges of the respective ring nuts close sandwich-like a portion about the hole of the basin. The second portion 202 is preferably *en bloc* with the waste pipe 340. The primary waste pipe 30 and the secondary waste pipe 35 are arranged along a common axis Z-Z generally orthogonal to the axis X-X of the waste pipe 340 (figure 17A), preferably diametrically opposed.

**[0049]** The bottom of the waste pipe 340 is closed and provided with a protrusion 341 whereon it is engaged a rotating cylinder as explained later.

**[0050]** Preferably, the second portion 202 of the drain 200, the waste pipe 340 and the primary waste pipe 30 and the secondary waste pipe 35 are realized *en bloc*. Alternatively, as shown in the section of figure 17D, the waste pipe 340 may be provided with an annular edge 342 radially protruding against which the threaded ring nut 203 of the second portion 202 stops when screwed on the first portion 201 of the drain 200.

**[0051]** The means for diverting the water flow comprise a rotating cylinder 500 having a general cup-like configuration that replicates the shape of the waste pipe 340 so as to be accommodated therein, preferably in a precise way. In particular, the cylinder

comprises a closed bottom provided with a first seat 501 recessed open outwardly and adapted to engage rotatably with the protrusion 341 of the waste pipe 340. Furthermore, the cylinder 500 comprises a second seat 502 open in the opposite direction with respect to its bottom, so as to accommodate a pin for controlling the diverting means, as later explained. It is to note that both the first seat 501 and the second seat 502 are arranged along the axis X-X of the drain 200 and of the pipe 340.

**[0052]** Preferably, the second seat 502 comprises a first portion 503 having a closed bottom with a polygonal, preferably triangular, cross section, and a second portion 504 having a cylindrical section.

**[0053]** Advantageously, the lateral wall 505 of the rotating cylinder 500 comprises an aperture 506 for the flow of the wastewater from the drain 200 to the waste pipe 340. Such aperture may be composed of a series of windows separated by a filtering grid, as shown in figure 17D.

**[0054]** The draining system 105 comprises also a filter basket 70 or strainer provided with a perimetral rim 71 (figure 17A-17D) for resting on the annular rim 342 of the waste pipe 340, a central hole (not shown) and with a series of radial apertures 72 arranged about said hole (figure 17C).

**[0055]** Preferably, a threaded bushing 73 is screwed in the second portion 504 of the second seat 502 of the cylinder 500 and so as to accommodate a portion of a control pin, as later described.

**[0056]** The draining system 105 further comprises a plug 800 for closing the drain 200. The plug is completely conventional and it will not be further described. It is only to note that such plug comprises a control element 610 or pin provided with a gripping element 611 for its operation. In particular, the pin 610 comprises a first portion 612 adapted to be inserted in the bushing 73 and a second portion 613 or end portion having a polygonal section, preferably triangular, so as to basically engage perfectly the first portion 503 of the second seat 502 of the rotating cylinder 500.

**[0057]** Generally, then, the draining system 105 also comprises a series of seal gaskets mounted between the various elements making it up. For example, as shown in figures 17A and 17D, a gasket G is fixed by means of a suitable ring R on the outer surface of the bottom of the plug 800 in a completely conventional way.

**[0058]** The just described system 105 advantageously allows to make constructively more compact and simplify the diverting means and the control means of said diverting means thus facilitating its operation. In fact, as shown in figure 17D, when the pin 610 is pressed towards the bottom of the plug 800, it occurs the draining closing in the drain

200 thanks to the stop caused by the above said gasket G and by the relative ring R against the strainer 71 so as to close its apertures 72. On the contrary, when lifted, the pin 610 allows the water flow in the drain 200 and, thanks to the rotation activated using the finger of one's hand on the gripping element 611 of the pin 610, it is controlled the rotation of the rotating cylinder 500 so as to position its aperture 506 in correspondence of the primary waste pipe 30 towards the sewage system or of the secondary waste pipe 35 towards the recovery system. It is to note that however also in the lowered position, that is when the plug is closed, the rotation can be activated all the same. In fact, it might happen that the recovery position remains active and the plug closed to allow the sink to be filled with soapy water for washing dishware. In this case, the opening of the plug would cause the soapy water to flow into the recovery system which would not be suitable for uses such as watering plants. Therefore the possibility to return to the sewage system having the plug closed allows to avoid such drawback.

**[0059]** An indicator (not shown) may be provided on the gripping element to see which is active whether the primary waste pipe or the secondary waste pipe. Of course, since the rotating cylinder 500 is open only on one side of its lateral wall, it will not allow the water flow on the diametrically opposite wall, thus directing it only where wanted.

**[0060]** Moreover, there can be provided stop systems for the rotation of the rotating cylinder 500, such as means 18 and 19 previously described which regulate the width of the rotation so as to make the aperture 506 overlap one between the primary waste pipe 30 and the secondary waste pipe 35. The system is then provided with overflow such as one similar to the one described with reference to figure 9.

**[0061]** In figure 18, there is shown a first variant 106 of the embodiment of the just described draining system 105 and shown in figures 17A-17D. The reference numbers in common refer to identical elements. In particular, the rotating cylinder 500 differs from the cylinder of the system of figure 17A for the presence of an annular band 506 arranged around the cylinder aperture and provided with gripping elements 507 through which it is possible to activate the rotation of the rotating cylinder 500. Consequently, the pin 610 can be a traditional pin to activate the closing of the plug 800. The operation of the diversion of the water flow will be the same as the one described with reference to the system 104.

**[0062]** In figures 19A-19C, there is shown an embodiment variant 107 of the draining system 105 of figures 17A-17D. The reference numbers in common refer to identical elements. In particular, the first seat 508 of the closed bottom of the rotating cylinder 500 is shaped so as to accommodate a timer device 509 to re-position the rotating

cylinder in the condition of the sewage system, that is that of draining water into the primary draining system. In practice, the timer device 509 comprises for example an elastic element or spring 510 (figure 19C) activatable by the control pin 610 through the rotation of the cylinder 500 so as to be loaded. Moreover, said elastic element 510 is connected to said rotating cylinder 500 through a brake (not shown) that releases the elastic force on the cylinder in a continuous and regular way to make the cylinder rotate in a controlled and continuous way. Alternatively, the elastic force of the loaded spring is transferred to a snap mechanism (not shown) that at once makes the rotating cylinder 500 rotate. Independently from how it rotates, the system comprises stop elements (not shown) such as those previously described. The operation of the diversion of the water flow will be the same as the one described with reference to the system 104.

**[0063]** In figure 20, there is shown a third embodiment variant 108 of the system 105 of figures 17A-17D. In this variant besides the elements in common referred to with the same reference number, the waste pipe 340 has a primary waste pipe 30, a secondary waste pipe 35 and a third waste pipe 350, preferably arranged along the circumference of the pipe at 120° one from the other. The third waste pipe 350 has the purpose of collecting water from the sink or wash-basin into a storage or decantation tank, for example, when its temperature is too high to be directly used for irrigation or when it contains food remains in suspension. It is to keep in mind that the arrangement of a plurality of waste pipes, for example more than two, can be envisaged also for the previously described systems with reference to the embodiments of figures 3-19. The operation of the diversion of the water flow will be the same as the one described with reference to the system 105, with the possibility, as explained, to select through rotation three different waste pipes.

**[0064]** In figure 21, there is shown another embodiment wherein a draining system 109 basically comprises the same elements previously described and the parts in common with the previous embodiments are referred to with the same reference number. In particular, the second portion 613 of the pin 610 for controlling the means for diverting the water flow has a semi-cylindrical form so as to engage the corresponding first portion 503 of the second seat 502 of the rotating cylinder 500 having a complementary section. Furthermore, the waste pipe 340 comprises a perforated bottom 342 which is connected, preferably in a reversible way, to a tank 900 for collecting the water that may potentially flow through the lateral walls of the rotating cylinder 500 and of the waste pipe 340 becoming stagnant on the bottom 342 of the same pipe, as it is neither drained in the primary waste pipe 30 nor in the secondary waste pipe 35 arranged diametrically

opposed on the same plane of the axis Z-Z. The collecting tank 900 is also provided with a pipe fitting 901 to the primary waste pipe 30 to make such stagnant water drain. The operation of diverting the water flow occurs as well through the rotation of the rotating cylinder 500, as previously described.

**[0065]** In figure 22 there is shown another embodiment variant 110 similar to the variant described with reference to the system 109 of figure 21, therefore the same reference numbers refer to identical elements. In particular the tank 900 for collecting stagnant water, which may ooze between the rotating cylinder 500 and the waste pipe 340, is made *en bloc* with the bottom 342 of the same pipe and the corresponding waste pipe 902 is too *en bloc* with the primary waste pipe 30, possibly separated by a baffle 903 which is a portion of the wall itself of the primary waste pipe 30.

**[0066]** In figure 23 there is shown a further embodiment 111 alternative to the systems 108-110. In particular, the alternative consists in providing a rotating cylinder 550 provided with two apertures 551 and 552 arranged on the lateral wall on two different planes, preferably an aperture lies at least partially on the plane defined by the bottom of the same rotating cylinder. Moreover, the apertures 551 and 552 are arranged along the cylindrical lateral wall preferably at 90° one from the other. Similarly, the waste pipe 345 comprises a primary waste pipe 30 and a secondary waste pipe 35 positioned at two different heights on its lateral wall, preferably the primary waste pipe is at least partially positioned at the bottom of the pipe and more preferably having an inclined part departing with respect to the lateral wall of the same pipe. Furthermore, the primary waste pipe 30 and the secondary waste pipe 35 are preferably positioned at 180° one from the other. The operation of the diversion of the water remains the same as previously described.

**[0067]** In figure 24A there is shown a further embodiment wherein a draining system 112 comprises a drain 210 provided with a first portion 211 for fixing on the bottom of the sink or wash-basin and a second portion 212 adapted to protrude from the lower or outer surface of the bottom of said sink or wash-basin so as to connect with a watertight seal with a cylindrical water waste pipe 360. The pipe 360 extends about a rectilinear axis X-X and is provided with a primary waste pipe 30 for the sewage system and a secondary waste pipe 35 for the recovery system. Means 560 for diverting the flow of wastewater are accommodated inside said waste pipe 360 and are selectively activatable so as to discharge water through said primary waste pipe or said secondary waste pipe. Said means 560 are activatable through a control 611 positioned above the level of the basin bottom of the sink or of the wash-basin.

**[0068]** In particular, besides the element in common with the previous embodiments which have the same reference number, the diverting means 560 are preferably a hollow rotating cylinder extending rectilinearly along the axis X-X and comprising a first annular flanged end 561, provided with a groove 562 for accommodating a gasket (not shown), a second cylindrical end 563 and an intermediate portion 564, cylindrical as well. The intermediate portion 564 comprises in its turn a first aperture 565 axially aligned with a second aperture 566 formed in correspondence of the second end. Axially, the cylinder comprises a rectilinear shaft 567 provided with first bayonet means 568 for the reversible coupling on the bottom of the waste pipe, as later explained, and a seat 569 for the engagement of the bushing 73 (figure 24C). Said seat 569 is divided into a first part 569A for the reversible engagement with said bushing, in a completely conventional way, and into a second part 569B for the engagement with the end portion 613 of the pin or rotating element 610.

**[0069]** On the contrary, the waste pipe 360 comprises a first portion 361, preferably *en bloc* with the second portion 212 of said drain 210, and a second portion 362, preferably separated from the first portion and connectable thereto with a watertight seal by means of rapid connections such as bayonet coupling or screwing. Furthermore, the first portion 361 of the pipe 360 comprises the secondary waste pipe 35, while the second portion 362 comprises the primary waste pipe 30, said primary waste pipe 30 and secondary waste pipe 35 are on two staggered planes and preferably diametrically opposed. Therefore, the rotation given to the rotating cylinder 360 by the control 611 through the pin 610 by means of the elements previously described, advantageously allows to select either the secondary waste pipe 35 or the primary waste pipe 30 alternatively thanks to the arrangement of the first aperture 565 and of the second aperture 566 axially aligned and to the corresponding pipes which on the contrary axially misaligned.

**[0070]** Furthermore, the second portion 362 of the waste pipe 360 comprises on its bottom second bayonet means 363 (figure 24D) adapted to cooperate with said first bayonet means of the shaft 567 of the rotating cylinder 560.

**[0071]** Now, the assembly of the system 112 requires the screwing of the bushing 73 in the seat 569 of the shaft 567 of the rotating cylinder 560, then the control 610, bearing the plug 800 as usual with its portion 612, is inserted in the bushing 73 and with the second portion 613 precisely engages the second portion 569B of the seat 569 of the shaft 567 of the rotating cylinder 560 (figures 24C and 24E). At this point, the rotating cylinder thus arranged can be bayonet fitted in the second part 362 of the waste pipe

360. Thanks to the above said engagement of the control element on the shaft 569 of the rotating cylinder 560 it is possible to rotate the same cylinder in the above said positions.

**[0072]** In the closing position of the system 112, as shown in figure 24C and 24E, both the first aperture 565 and the second aperture 566 face towards the closed lateral wall respectively of the first portion 361 and of the second portion 362 of the waste pipe 360. Moreover, the first 568 and second 363 bayonet means respectively of the rotating cylinder 560 and of the waste pipe 360 are disengaged so as to allow the extraction of the same rotating cylinder from the pipe for the maintenance and cleaning of the system. On the contrary, when for example the system is in the position of the sewage system, as shown in figures 24G and 24I, or in the position of the recovery system, the bayonet coupling does not allow the extraction of the above said cylinder so as to avoid unwanted water leaks along the whole draining system.

**[0073]** In figures 25A-25D there is shown a further embodiment wherein a draining system 113 comprises a drain 220 provided with a first portion 221 for fixing on the bottom of the sink or wash-basin and a second portion 222 adapted to protrude from the lower or outer surface of the bottom of said sink or wash-basin so as to connect with a watertight seal to a cylindrical water waste pipe 370. The pipe 370 extends about a rectilinear axis X-X and is provided with a primary waste pipe 30 for the sewage system and a secondary waste pipe 35 for the recovery system. Means 570 for diverting the wastewater flow are accommodated inside said waste pipe 370 and are selectively activatable so as to discharge water either through the primary waste pipe or through the secondary waste pipe. Said means 570 are activatable by means of a control 611 positioned above the level of the basin bottom of the sink or wash-basin.

**[0074]** In particular, besides the elements in common with the previous embodiments which have the same reference number, the diverting means 570 are preferably a first truncated cone –shaped element 571 and a second element 572 both hollow. The first element 571 has an open major base facing the axial primary waste pipe 30 and a closed minor base 574 facing the opposite with respect to the major base (figures 25C and 25D). The major base is surrounded by a flange 575 for fixing on the inner wall of the waste pipe 370. The minor base is instead provided with an axial pin 576 protruding towards the outer part of the first cone-shaped element 571, preferably surrounded by elements 577 for rotating coupling (figures 25C and 25D) with the second element 572. Such elements 577 can be elements such as rotating bearings. Advantageously, the



lateral wall of the first element 571 is provided with an opening W for draining water into the secondary waste pipe 35, as later described.

**[0075]** The second element 572 comprises an axial truncated cone-shaped portion 578 preferably surrounded by a peripheral cylindrical portion or mantle 579. The axial portion 578 is complementary to the first element 571 so as to substantially fit it precisely. Consequently, also the second element comprises an open major base and a closed minor base. The major base comprises a flange 580 for the connection with the cylindrical mantle 579. Further, the mantle surrounds axially only a part of the axial portion 578 and only a wall 581 extends axially beyond the mantle towards the minor base of the same axial portion. From the minor base, then prolongs a seat 582 for accommodating the control pin 610 of the rotation and the related bushing 73, analogous to those previously described. Furthermore, also the lateral wall of the axial portion 578 comprises an aperture W1 (figures 25A and 25D) coinciding with the aperture W of the first element 571. It is to keep in mind that the aperture W1 on the lateral wall of the axial portion 571 is radially staggered with respect to the wall 581 of the cylindrical mantle 579, preferably staggered by about 90°.

**[0076]** The waste pipe 370 is basically a cylindrical pipe extending rectilinearly along the axis X-X and comprises an axial primary waste pipe 30 and a radial secondary waste pipe 35, orthogonal to the axis X-X and formed in the proximity of the drain 220.

**[0077]** Consequently, the system 113 can operate in a first mode wherein the first element 571 of the means 570 for diverting the water flow is fixed inside the waste pipe 340 with its major base downstream the secondary waste pipe 35 and the minor base basically in correspondence of said secondary waste pipe 35. The aperture W of the first element is preferably oriented at 90° with respect to said secondary waste pipe 35. The second element 572 of the means 570 for diverting the water flow is rotated on the first element 571 so as to have the aperture W1 overlapped with the aperture W. In this position, the wall 581 of the cylindrical mantle 579 of the second element 572 closes the secondary waste pipe 35, therefore causing the water to flow through said apertures W and W1 of the first diverting means 571 and of the second diverting means 572, which are overlapped and then in order to directly flow into the primary waste pipe 30 through the aperture 573 of the major base of the first element 571.

**[0078]** Conversely, by acting on the control 611, the pin 610 causes the second element 572 to rotate onto the first element 571 preferably by 90° so as to bring the aperture W1 of the second element radially staggered with respect to the aperture W of the first element. At the same time, the wall 581 of the second element 572 positions itself away

from the secondary waste pipe 35. Consequently, the water from the drain 220 cannot flow through the two apertures W1 and W, therefore it cannot flow through the aperture 573 of the first element 571 to drain into the primary waste pipe 30. On the contrary, flows freely into the secondary waste pipe 35.

**[0079]** In figures 26A-26C there is shown a further embodiment wherein the multiple draining system 114 comprises a drain 230 provided with a first portion 231 for fixing on the bottom of the sink or wash-basin and a second portion 232 adapted to protrude from the lower or outer surface of the bottom of said sink or wash-basin so as to connect with a watertight seal with a cylindrical water waste pipe 380. The pipe 380 extends about a rectilinear axis X-X and is provided with a plurality of pipes 30, 35, 36. Means 583 for diverting the wastewater flow are housed inside said waste pipe 380 and are selectively activatable so as to discharge the water through one of said plurality of pipes. Said means 583 are activatable through a command 610 located above the bottom level of the sink or wash-basin.

**[0080]** In particular, besides the elements in common with the previous embodiments which have the same reference number, the water diverting means 583 have preferably a cup-like shape comprising a closed bottom 584 and provided with a seat 585 for the engagement of the pin 610 for controlling the rotation, by the insertion of the bushing 73, and a seat 586 for the rotating engagement with a rotation axis of the bottom of the waste pipe 380. In particular, the lateral wall of the cup 583 comprises an aperture W2 located in the proximity of the bottom 584 for diverting the water flow into one of said plurality of pipes (figure 26C).

**[0081]** The waste pipe 380 too has preferably a cup-like shape so as to be complementary to the above said water diverting means 583. In fact, said means 583 are rotatably and substantially precisely accommodated inside said waste pipe by means of the engagement of a rotating axis 587 of the bottom of the pipe with the above said seat 586 of the diverting means, preferably a bayonet coupling as in the foregoing. Advantageously, the pipe comprises a plurality of pipes 30, 35, 36 radially staggered, preferably by about 120°, along the lateral wall so as to form a primary waste pipe 30 for the sewage system, a secondary waste pipe 35 for recovery water for domestic use or for irrigation and a third pipe 36 for other uses or for collecting into a tank (not shown) for storage, cooling or decantation before a subsequent domestic or irrigation use. Furthermore, similarly to what envisaged for the system 111 of figures 23A-23D, also in this system there may be provided the sewage pipe located starting from the bottom of the cup of the waste pipe 380 so as to let out possible remaining water.

**[0082]** The operation of the just described system 114 is very simple and intuitive since, as in the foregoing, through the control 611 it is possible to rotatably activate the pin 610 which transfers the motion to the cup 583 in order to select the desired one of said plurality of pipes causing the aperture W2 of the same cup to overlap exactly the primary waste pipe 30, the secondary waste pipe 35 or the third pipe 36.

**[0083]** Furthermore, the compactness and constructive simplicity of the present solution allow an easy assembly, simple maintenance, low production costs, besides a minimum bulk in the lower part of the sink.

**[0084]** In figure 27 there is shown a different embodiment wherein the multiple draining system 115 comprises a drain 240 provided with a first portion 241 for fixing on the bottom of the sink or wash-basin A and a second portion 242 adapted at protruding from the lower or outer surface of said sink or wash-basin so as to connect with a watertight seal with cylindrical water waste pipe 480. The pipe 480 extends about a rectilinear axis X-X and is provided with a plurality of pipes 30, 35. Means 683 for diverting the wastewater flow are accommodated inside said waste pipe 480 and are selectively activatable so as to discharge water through one of said plurality of pipes. Said means 683 are activatable by means of a control 610 located above the bottom level of the basin of the sink or of the wash-basin and lying on said axis X-X.

**[0085]** In particular, besides the elements in common with the previous embodiments which have the same reference number, the water diverting means 683 (figure 28) preferably have a cylindrical shape with a lateral wall 684, a bottom 685 and an aperture 686 axially opposed to said bottom. On the lateral wall there is at least a hole 687 for the wastewater flow formed in the proximity of the bottom 685. Preferably, there are a first hole 687 and a second hole 687 radially staggered by 90° and located at the same level. A window 688 is then formed in the proximity of the aperture 686. As later described, said holes have the purpose of directing wastewater either towards the sewage system or towards the recovery system, while the window 688 acts as an overflow and positions itself in correspondence of a similar window (not shown) formed on the waste pipe 480 this too connected to the conventional overflow hole (not shown) of the basin.

**[0086]** The bottom 685 is provided with a through hole 689 (shown in figure 29B) in continuity with an inner sleeve 690 whose cavity is such that it fits on a pin for the rotation of the waste pipe, as later explained. From the free edge of the sleeve extend first elements 691 for the engagement with second engaging elements 400 (figure 28), said second elements being connected to a rotation control in order to control the

rotation of the water flow diverting means 683, as described later. Preferably, the first engaging elements 691 are constituted by a plurality of walls against which the second engaging elements 400 engage themselves pushing them to rotate about the axis X-X. In particular, the walls are three and are separated one from the other by specific spaces 692 (only one shown in figure 28) between which said second elements 400 engage themselves. The spaces are preferably arranged on a circumference and spaced by 120°.

**[0087]** In particular, as shown in figures 29A-29B, the cross section of the inner cavity of the sleeve 690 shows a first narrow and constant section 693 farther from the bottom 685 of the cylinder 683 and a second enlarged section 694 closer to the bottom 685. Said second section 694 comprises a first radial extension 694A having a radius greater with respect to a second annular extension 694B. In this way, two circumferential steps 695 are formed on the inner wall of the sleeve that constitute two stop points of the rotation of the rotating cylinder 683 on the cylindrical pipe 480.

**[0088]** The water diverting means 683 are accommodated inside the water waste pipe 480 (figure 28). This pipe has preferably a cylindrical form complementary to that of said diverting means. In particular, the pipe comprises a lateral wall 481 provided with holes communicating with a plurality of water waste pipes. Preferably the pipes are two: a pipe for recovering water 35 and a pipe 30 for the sewage system. Further, the two pipes are diametrically opposed. From the bottom 482 of the cylindrical pipe raises a hollow pin 483 whose cavity constitutes the fixing seat of the bushing 73 and on whose outer wall rotatably fits the sleeve 690 of the rotating cylinder 683. Preferably, at the base of said seat 483 there is an annular seat 484 for accommodating an elastic element 509 such as the spring described in the foregoing. Furthermore, the base of the seat 483 has in its cross section a radial tooth 487 (figure 30B) adapted to engage the above said first radial extension 694A of the second section 694 of the seat 690 of the water diverting means 683. It is also to note that the bottom 482 is advantageously inclined with the incline towards either one of the two waste pipes of the sewage system or of the recovery system in order to avoid water stagnations (figure 34B).

**[0089]** The aperture 485 of the pipe wherefrom the diverting means are inserted is surrounded by a flange 486 provided with a series of ribs 488 for holding an O-ring gasket O1 (figure 27).

**[0090]** The water diverting means 683 are made to rotate inside the pipe 480 by means of an *en bloc* control 620 with a gripping knob 621 (figure 27). In turn, the control 620 comprises a first portion 622 extending axially from the knob and locks together with a

second portion 623, the latter being such that it reversibly locks inside said bushing 73. Between the control 620 and the bushing 73 there are locked together a closing plug 810 with the respective gasket 811 (figure 27) and the above said second elements 400 for the engagement with the first engaging elements 691 of the rotating cylinder of the water diverting means 683.

**[0091]** In particular, as shown in figures 31A-31C, the second elements 400 preferably comprise a plurality of feet 402 which engage the first elements 691 of the rotating cylinder 683. The feet are preferably three and extend in correspondence of the edge of a first flat face 403 of a circular base 401 and perpendicular to the latter. Furthermore, the three feet are arranged on the base at 120° one from the other. More preferably, they generally show a hooked cross section so as to engage an edge of said walls defining the above said space 692 between the same walls 691 of the rotating cylinder 683. On the second face 404 of the circular base 401 protrudes a tooth 405 adapted to engage a corresponding hole 406 formed on the plug 810 (figure 32). Centrally, the base 404 is crossed by a through hole 406 for locking together with the above said first portion 622 of the control 620.

**[0092]** The second portion 242 of the drain (figures 33A-33C), also called strainer, comprises a perforated bottom, having preferably three circumferential holes extending for about 120° shaped as an arc of a circle so as to allow the rotation of the above said three feet 402 of the second elements 400. Said holes then surround a central hole 811 for engaging the first portion 622 of the control 620, in a completely conventional way.

**[0093]** The assembly of the just described draining system 115 envisages a first step wherein the rotating cylinder 683 is fitted inside the waste pipe 480. When is inserted, the sleeve 690 of the rotating cylinder is fitted on the fixing seat 483 of the bushing 73 in the waste pipe 480 so as its first radial extension 694A of the second section 694 of the sleeve 690 engages with the radial step 487 of the seat 483 of the bushing 73 of the pipe 480 thus realizing a bayonet coupling. It is to note that the length of the first annular extension is such that it allows a rotation by 90° of the radial step, and hence of the rotating cylinder between the two stop points 695 of the same extension (figures 29B-30B). In particular, the arrangement of the first annular extension 694A and of the corresponding annular step 487 are such as to selectively direct one of the two apertures 687 of the rotating cylinder 683 towards either the sewage system 30 or towards the recovery system 35, while the other one is closed by the lateral wall 481 of the waste pipe 480.

**[0094]** The control element 620 is assembled by locking together in succession the plug 810 on the first portion 622, then the gasket 811 of the plug, the second engaging elements 400 so as insert their tooth 405 into the hole 406 of the plug and finally the second portion 633 of the control element.

**[0095]** The fixing bushing 73 between the control element, the drain 240, the water diverting means 683 and the waste pipe 480, is blocked in the seat 483 of the same pipe and, finally, the control element assembled as above, is reversibly fitted in the bushing 73 with the second portion 623 by means of conventional elastic elements. The bushing blocking can be made by locking or by means of a screw-like engagement (figure 34B).

**[0096]** The advantage of the just described draining system 115 lies in the constructive simplicity which requires few modifications with respect to the traditional systems. Practically, the elements which make up the control and the plug are the same as the conventional ones, while the rotation means are constituted by a cylinder which accommodates therein a conventional drain and that, in turn, is accommodated inside a very compact waste pipe. Furthermore, the rotation mechanism comprises an engaging element for the rotation of the cylinder provided with a simple and efficient structure for transmitting the rotation given by the control element to the cylinder.

**[0097]** In fact, as shown in figure 35, the system 115 is arranged in the sewage system condition wherein one of the two apertures 687 of the rotating cylinder 683 is in communication with the sewage waste pipe 30, while the other aperture 687 is closed by the lateral wall 481 of the waste pipe 480.

**[0098]** As shown in figure 36, by rotating the knob 621 of the control 620 for example in the clockwise direction by 45°, both apertures 687 of the rotating cylinder 683 are closed by the lateral wall 481 of the waste pipe 480. Therefore, in this position, advantageously, a further safety is achieved in case fluids or small object might fall in the sink as they would not flow into the waste pipe. Moreover, in this way the communication with the draining system can be closed thus preventing unwanted smells from surfacing.

**[0099]** As shown in figure 37, a further rotation of the knob 621, for example in the same clockwise direction by 45°, allows one of the apertures 687 to communicate with the recovery pipe 35, while the other aperture is closed by the same wall 481 of the waste pipe 480.

**[00100]** Figure 38 is an exploded view of an embodiment similar to the previous one, therefore the identical elements have the same reference number and will not be

described any further. In particular, the system 116 comprises water diverting means 630 that preferably are made up of a rotating disc having two holes 631 for alternatively draining to the sewage or to the recovery systems (figure 39), preferably at 90° in the proximity of the circumference of the disc.

**[00101]** As also shown in figures 40A-40D, the disc 630 shows a first surface 632 and a second surface 633 which are opposite and generally flat crossed by said two holes 631 arranged in the proximity of the circumference and a central engaging hole 634 with a pin for rotating the waste pipe and the fixing seat of the bushing 73. In particular, from the first surface 632 and about the central hole 634 raises a sleeve 635 similar to the sleeve 690 described with reference to the system 115. Said sleeve has therefore first elements 636 the same as the first elements 691 previously described and separated by spaces 636A between which engage the previously described second elements 400.

**[00102]** Furthermore, from the first surface 632 stand two hollow towers 637 (figure 40B), preferably having an arc of a circle section, diametrically opposed. In particular, one tower is located between two draining holes 631. Said towers have their inner cavity in communication with corresponding holes 638 opening on the second surface 633 of the disc (figure 40C).

**[00103]** It is to note that also the section of the sleeve 635 is the same as the one of the sleeve 690 previously described (figure 40D).

**[00104]** The draining system 116 further comprises a waste pipe 530 provided with a first cylindrical portion 531 and a second discoid portion 532 (figure 38). The second discoid portion 532 comprises a first opposed surface 533 and a second surface 534, both generally flat (figure 41A-41C). From the peripheral edge of the first surface 533 raises an annular band 535 provided with a groove 536 (figure 39) for accommodating a gasket O2 of the O-ring type (figure 38). Furthermore, from the first surface 533 raises centrally a seat 537 for fixing a bushing 73, identical to the seat 483 described for the system 115. Also the section of said seat 537 is identical to the one previously described. Preferably, the seat 537 has an aperture 538 (figure 41B) that allows to discharge water in case it might ooze inside the same seat so as to be discharged either into the sewage waste pipe 30 or into the recovery waste pipe 35 according to the position of the diverting means. Further, the first discoid portion 532 has two through holes 539 diametrically opposed. Each one of these holes communicate respectively with either the sewage waste pipe 30 or with the recovery waste pipe 35, such pipes extending from the second surface 534 of said second discoid portion 532 (figure 41B).

**[00105]** Preferably, one of the two holes 539 and that is the one connected to the recovery waste pipe 35, is surrounded by a groove 540 adapted to accommodate an O3 gasket (figure 38).

**[00106]** The first portion 531 of the waste pipe 530 has a cylindrical sleeve-like shape with a flange 541 formed in the proximity of a first axial aperture 542 radially facing inward (figure 42B). Preferably, the flange comprises one or more grooves 543 for the engagement with an O1 seal gasket. In correspondence of the second axial aperture 544, the first portion 531 comprises a flaring 545 whose peripheral edge is such that it engages with the peripheral edge of the annular band 535 of the first portion 531 of the pipe 530 with the insertion of the above said O2 gasket.

**[00107]** The assembly of the just described draining system 116 requires the preparation of the plug by means of locking together the control element 620 with the plug 810, with the second engaging elements 400 inserting the gasket 811 and with the first portion 622 of the control element, as previously described.

**[00108]** The sleeve 635 of the diverting means 630 is fitted on the seat 537 of the first portion 532 of the waste pipe 530 so as to insert the second surface 633 of the diverting means into the space defined by the annular band 535 of the same second portion. As previously, to do so, the sections of the sleeve 635 and of the seat 537 must be aligned so as to realize the bayonet coupling. Once the diverting means 630 have been arranged on the first portion 532 of the waste pipe 530, the second portion 531 of the same pipe can be mounted through the above said engagement between the peripheral edge of the flaring 545 of the first portion 531 and the peripheral edge of the annular band 535. Preferably, a retaining ring R1 (figures 38, 44-46) is fitted in the space defined between the seat or pin 537 for the rotation of the diverting means 630 and the sleeve 635 of said means so that from one side it engages a circumferential groove (not shown in the drawings) at the base of the seat 537 and on the other side it basically rests on a flange (not shown in figures) inside said sleeve. In particular, the ring has a cut typical of the commercial rings called seeger rings.

**[00109]** At this point, the bushing 73 can be fixed in the seat 537 and the above said assembly made up of control element 620/plug 810 together with gasket 811/second engaging means 400 can be fixed inside the waste pipe 530 with the insertion of the drain 240.

**[00110]** The operation of the system 116 is similar to the one previously described. In fact, rotating the knob 621 of the control element 620, it is achieved the rotation of the means 630 for diverting the water flow thanks to the above said engagement of the



second engaging elements 400 with the walls 636 of the sleeve 635 of the same diverting means.

**[00111]** The above said rotation involves, as shown in figure 44, the positioning along the axis X-X of one of the two holes 631 in correspondence of one of the two holes 539 of the first portion 532 of the waste pipe 530, which in turn is in communication with the recovery waste pipe 35, while the other hole 631 will be covered by the first surface 533 of said first portion.

**[00112]** It is to note that in this position, should the recovery pipe be connected with a full storage tank and the water should go back inside the same pipe up to the drain 240 (dashed line of figure 43B), the aperture on top of each hollow tower 637 would act as an overflow making the water flow into a space between the second surface 633 of the diverting means 630 and the first surface 533 of the first portion 532 of the waste pipe 530. Oozing, such water would trickle into the other aperture 539 of the first portion which is in communication with the sewage waste pipe 30.

**[00113]** As in the foregoing, by further rotating the knob clockwise it is achieved the closing of the waste pipe 530 (figure 45) and a further rotation still clockwise would bring the system into sewage position (figure 46). Such positions are completely similar to those previously described with the difference that they take place so as to make the holes coincide along the axis X-X of the system in order to make water flow from the drain to either the recovery waste pipe or to the sewage waste pipe.

**[00114]** With reference to figures 47-50, there is shown a variant of the embodiment described with reference to the system 116 of the figures 38-46. Equal elements have the same reference number and therefore they will not be described. In particular, the draining system 117 differs from the previous one since the second engaging means for the rotation of the means 630 for diverting wastewater flow, comprise a first portion 421 basically corresponding to the second elements 400 previously described. In fact, as shown in figures 49A-49B, the first portion 421 is provided with three feet 422 of which one has a sectional form different from the sectional form of the other two so as to make more immediate the orientation of the engagement with a second portion of said engaging elements. For example, as shown, two feet have a hook-like section as the feet of the previously described elements 400 while the third one has an elliptical section.

**[00115]** The second portion 423 of the second engaging rotating elements, as shown in particular in figure 50, comprises a base 424 preferably having a perforated disc-like shape as a kind of filter. The base also comprises a central hole 425 for the passage of

the control element 620 and three hollow feet 426 having a section complementary to the feet 422 of the first portion 421 so as to accommodate the same therein.

**[00116]** The assembly is substantially the same as the one described with reference to the previous embodiment, with the sole variant that between the drain 240 and the diverting means 630 there is inserted the second portion 423 of the second engaging rotating elements so that the base 424 acts as a filter (figure 48). Furthermore, a threaded ring D is screwed on the bushing 73 to block said second portion 423 at a preset distance from the drain 240 but anyway allowing both its rotation and its function as a filter for possible dirt, without hindering the water flow.

**[00117]** Figure 51 shows a system 118 wherein the reference numbers equal to those of the previous embodiments show equal elements which will not be further described. In general the system 118 comprises, it too, just like the aforementioned systems 116 and 117, means 650 for diverting the water flow having a rotating disc-like shape and a water waste pipe 590 comprising a first discoid portion 592 and a second sleeve-like portion 591.

**[00118]** In particular, the diverting means 650, as better shown in figures 52A-52B, comprise a flat and preferably disc-like base 651 having a first surface 652 and a second surface 653 opposed to the first. The first surface 652 has two concentric and axially perforated protrusions 654. A first central hole 655 having a polygonal shape, preferably triangular, is surrounded by a series of apertures 656, preferably three of them, shaped as an arc of a circle. Two second holes 657 are arranged in correspondence of the perimeter of the base 651 and spaced by about 90°, one for the sewage system and one for the recovery system. A third hole 658 opens on the second face 653 (figure 52B) and is in connection with a hollow tower 659 which raises from the first surface 652 and it has an open top communicating with said third hole. Preferably the tower 659 is located at about 135° from both second holes 657.

**[00119]** As shown in figure 52B, the two concentric protrusions 654 internally comprise a first section 670 and a second section 671 in the shape of an arc of a circle having a different radius so as to form two stop points 672 for the rotation on the second portion 592 of the waste pipe 590, as later described.

**[00120]** The second portion 591 of the waste pipe 590 corresponds to the second portion 531 of the waste pipe 530 previously described with reference to the system 117 (figure 51).

**[00121]** The first portion 592 of the pipe 590 comprises a first surface 593 opposed to a second surface 594 (figures 53). From the peripheral edge of the first surface 593 raises

an annular band 595 identical to the one described with reference to the system 117. Further, still from said first surface 4 raises a fixing seat 596 of the bushing 73. Said seat preferably comprises an aperture 597 at the base for draining water should it ooze therein. Two holes 510 and 511 are located diametrically opposed in the proximity of said annular band 595. Such holes 510 and 511 each communicates with the recovery waste pipe 35 and the sewage waste pipe 30.

**[00122]** Advantageously, the first surface 593 comprises a portion 593A inclined from the hole 510 communicating with the recovery pipe 35, towards the hole of the sewage pipe 30 so as to make probable stagnant water fall, due to gravity, onto said first surface towards the sewage pipe.

**[00123]** In accordance with a particular embodiment, the seat 596 comprises a base 598, with said aperture 597, wherefrom it raises a plurality of feet 599 adapted to firmly engage corresponding grooves formed on a connecting element 430 between the bushing 73 and the first portion 592 of the water waste pipe 590. In fact, as shown in figures 54 the connecting element 430 is preferably in the form of an internally threaded nut so as to engage the counter thread of the bushing 73 and provided with an outer surface having said grooves 431. It is to note that anyway the base 598 of the first portion 592 of the pipe 590 has two peripheral sections having a diameter so as to receive the above said first peripheral section 670 and second peripheral section 671 of the concentric protrusions 654 of the water diverting means 650 so as to realize a bayonet coupling.

**[00124]** The draining system 118 further comprises a control element 690 (figure 51) substantially similar to the one described for the draining system 105. In particular, the control element 690 comprises a first portion 691 provided with a gripping knob 692 and a pin for locking in a second portion 694 for reversibly fixing inside the bushing 73. The second portion 694 comprises an end 695 for the engagement with the polygonal hole 655 of the water diverting means 650. Preferably, such end has a triangular section which couples with the triangular section of the polygonal hole 655. As in the foregoing, the pin 693 and the second portion 694 of the control element 690 can be realized *en bloc* and have on the outer surface elastic elements for a reversible radial engagement inside the bushing 73 to allow the conventional closing of water draining by means of the drain 240 through the plug 810. It is to note that in this embodiment the plug 810 does not comprise any supplementary hole besides the conventional radial holes, therefore it can be found on the market and it does not need any adjustments.

**[00125]** The assembly of the just described system 118 is similar to that of the system 117 and requires to lock together the first portion 691 of the control element, the plug 810 with gasket 811 and second portion 694 still of the control element 694. Then, the water flow diverting means 650 are fitted on the seat 596 of the first portion 592 of the waste pipe 590 so that the respective first 670 and second 671 sections of the concentric protrusions 654 couple with the section of the base 596 of the first portion 592. Now, the connecting element 430 is fastened to the seat 596 of the first portion 592 by fitting the feet 599 with the grooves 431. At this point, the bushing 73 is screwed inside the connecting element 430 inserting the drain 240 with the respective O1gasket.

**[00126]** Other gaskets can be provided and placed in the same points as previously described.

**[00127]** Note that assembled as such, the system 118 has the connecting element 430 fixed at a certain distance from the surface of the concentric protrusions 654 to allow the free rotation of the water flow diverting means 650 (figure 55).

**[00128]** As shown in figure 56A, in a first operating condition, the control 691 is in the recovery system position. In fact, one of the two second holes 657 of the wastewater flow diverting means 650 is in communication with the recovery waste pipe 35. On the contrary, the other one of the two holes 657 is covered by the first surface 593 of the first portion 592 of the waste pipe 590.

**[00129]** By rotating the control 690 for example by 45° clockwise by means of its knob 692, the end 695 pushes into rotation the diverting means 650 positioning both second holes 657 to close on the first surface 593 of the first portion 592 of the waste pipe 590 (figure 56B).

**[00130]** By rotating again the control still for example by 45° clockwise, one of the two second holes 657 positions itself in communication with the sewage waste pipe 30 while the other one is closed by said first surface of the first portion of the waste pipe.

**[00131]** The advantage obtained with this last embodiment lies in the fact that the rotation control is essentially the same as a conventional plug. In fact, the circular portion with radial apertures does not need to be perforated in order to lock together with the tooth of the rotation means 400 described with reference to the embodiments 116 and 117. Also these same rotation means can be avoided since their function is carried out by the three feet 599 of the seat 596 which is part of the waste pipe. Therefore, besides the diverting means 650, it will be sufficient to arrange the waste pipe with a second portion having a very simple shape such as that of a sleeve and a

first generally discoid portion with the above said seat for the fixing bushing with the drain.

**[00132]** This means that the entire construction and production are simplified with resulting lower costs.

**[00133]** Furthermore, as schematically shown in figures 51 and 56A-56C, the system 118 can comprise, it too, a spring 509 or elastic element to control the slowed return of the diverting means for example from the recovery system position to the sewage system position. Such mechanism, as already explained, has the function of preventing water containing soaps or other substances, which would not be suitable for reuse such as for watering plants and/or gardens, from flowing into the recovery system. The spring 509 can be accommodated in a bottom portion B of the second portion 592 of the waste pipe 590 and associated to a pin P for the connection with the end 695 of the control 690. Moreover, a flat gasket O5 can be inserted between the first portion 592 of the waste pipe 590 and the diverting means 650. Such gasket is perforated only in correspondence of the holes 510 and 511 of the second portion 592 to ensure watertightness when one of the second holes 657 of the diverting means 650 is not aligned with the respective hole 510 and 511.

**[00134]** In figure 57, the system 119 for discharging water from sinks or wash-basins is similar to the previously described system 118 with reference to figures 51-56, therefore the same reference number will refer to equal elements and will not be described any further. In particular, the system 119 comprises means 640 for diverting wastewater flow having the shape of a cylindrical container.

**[00135]** As better shown in figures 58A-58C, the diverting means 640 have a circular bottom 641 and an annular lateral wall 642. The bottom comprises two first holes 643 located in the vicinity of its circumference and preferably spaced by 90°. These first holes are connected, as either with the recovery waste pipe or with the sewage waste pipe as later explained. Two second holes 644 are located along said circumference and are diametrically opposed. Moreover, the second holes communicate each with a corresponding tower 645 (only one is shown in figure 58D) for discharging overflow water identical to the overflow towers previously described.

**[00136]** Two concentric protrusions 646 axially perforated and overlapped raise from the bottom 641. A first central hole 647 of the protrusions has a section such as to accommodate precisely the end of the control, preferably having a polygonal section and more preferably a triangular section. The central hole is then surrounded by a series of apertures 648 shaped as an arc of a circle, preferably three.

**[00137]** Advantageously, the inner surface of the bottom 641 comprises an inclined ramp-like portion 649 (figure 58C). Preferably, said portion 649 has the higher point far from the first two holes 643 and an inclined ramp towards the same holes so as to facilitate the elimination of possible stagnant water on the same bottom (figures 58B and 58C). Note that such ramp can be provided also for the previous embodiments whose diverting means are made up of cylinders, cup-like containers and rotating discs.

**[00138]** The inner section of the two concentric protrusions 646 has the same trend as the one described with reference in particular to the system 118. Therefore, such section comprises two points 646A of the rotation stop on the second portion of the waste pipe, as later described.

**[00139]** The waste pipe 520 of the system 119 comprises a second portion 521 and a first portion 522 (figure 57). The second portion 521 basically corresponds to the second portion 591 of the system 118. The first portion 522 (figures 59A-59B) has a general structure substantially identical to the first portion 592 of the system 118. Preferably, this first portion comprises an annular seat 523 located between the holes 524 and 525 diametrically opposed and in communication respectively with the recovery waste pipe 35 and the sewage waste pipe 30, as for the holes 510 and 511 of the embodiment 118. The annular seat is such as to accommodate a corresponding seal gasket O4 (figure 57) when either one or the other of the two holes 642 of the diverting means 640 are closed by the discoid surface of the first portion 522 of the pipe 520. Preferably, the diameter of the gasket basically coincides at least with the diameter of the hole of the sewage waste pipe 30 and more preferably, is greater than the diameter of the hole of the recovery waste pipe 35. In other words, as shown in figures 61A and 61B, the seal gasket O4 is firmly positioned at 90° between the two holes 524, 525 so as to overlap the hole 642 of the diverting means 640 for draining in the sewage waste pipe 30 or the hole 642 for draining in the recovery waste pipe 35, this because, as explained, the gasket is located at 90° between said holes 642 diametrically opposed.

**[00140]** Note that said first portion 522 of the waste pipe 520, as for the system 118, comprises a first surface 526 provided with an inclined portion 526A inclined from the hole 524 of the recovery waste pipe towards the hole 525 of the sewage waste pipe.

**[00141]** Furthermore, from the first surface 526 peripherally raises an annular band 527 the same as the annular band 595 of the system 118, while in axial position there is a seat 528 for the firm engagement with a connecting element 430 between the bushing 73 and the first portion 522 of the waste pipe 520. Said seat 528 and the corresponding connecting element 430 are the same as those previously described with reference to

the system 118. Therefore, the same seat has a base 529 having such peripheral sections so as to receive the inner section of the aforementioned concentric protrusions 645 of the water diverting means 640, in completely the same way as for the system 118.

**[00142]** The draining system 119 also comprises a control element 690 (figure 57) identical to the control element of the system 118.

**[00143]** Also the assembly and the operation of the system 119 is the same as those previously described with reference to the system 118, therefore they will not be described any further. In figure 60 there is shown the interlock between the first portion 522 and the connecting element 430 with the insertion of the water diverting means 640.

**[00144]** In figure 62, the draining system 120 is an embodiment variant wherein the elements in common with the previous embodiments have the same reference number. The present system differs from the previous ones because it enable to simplify to the maximum the variations with respect to traditional draining systems. In fact, the plug 800 with the respective control 611 and pin 610 are completely conventional just as the drain 250, the strainer 70 and the bushing 73 for fixing the strainer to the drain. The pin 610 comprises only one shaped end 613 as for the previous embodiments. Therefore, the only pieces which are substantially modified are the waste pipe 440 and the diverting means 280.

**[00145]** Actually, the diverting means 280 are similar to the diverting means 640 described with reference to the system 119. In particular, they have a general cylindrical shape with a bottom 281 and a lateral wall 282. The bottom comprises a first 283 and a second 284 protrusion facing inward, hollow and coaxial, wherein the first protrusion overlaps the second (figures 63, 64). The first protrusion 283 has a cavity so as to precisely accommodate the section of the end 613 of the control 610, preferably polygonal, to allow the rotation control of the same means. Furthermore, preferably, the first protrusion 283 is perforated so as to allow the draining of the water that would possibly leak therein. The second protrusion 284 has instead a seat open outward so as to accommodate the above said rotation pin through a bayonet coupling as the one previously described.

**[00146]** Furthermore, the diverting means 640 comprise a first through hole 285 and a second through hole 286 formed on the bottom, in the proximity of the lateral wall and spaced by 90°. These holes, as in the foregoing, are so as to be alternatively

overlapped to corresponding holes of the recovery waste pipe and of the sewage waste pipe.

**[00147]** Also the bottom 281 comprises a ramp 287 (figure 63) as the one previously described and from the bottom circumference raises an annular band 288 provided with an outer threading (figure 62).

**[00148]** The waste pipe 450 comprises a first portion 451 and a second portion 452. The first portion 451 is similar to the first portion for example of the systems 117, 118 wherein the bottom is inclined to allow remaining water to be drained into the sewage waste pipe. Moreover, a pin 453 raises axially having a circumferential portion such that it engages with the seat of the second protrusion 284 of the diverting means 280 so as to realize the above said bayonet coupling and to allow the rotation of said means controlled by calibrated stop points, as already explained, so as to make the holes 285, 286 of the diverting means coincide alternatively with the waste pipes of the sewage or recovery systems.

**[00149]** The second portion 452 of the waste pipe 450 has a lid-like shape with a bottom 454 and a lateral wall 455, wherein the lateral wall ends with a flange 456 threaded internally for the engagement with the annular band 288 of the first portion 451 (figures 63, 64). The bottom 454 has a central hole 457 surrounded by a ring nut 458 internally threaded for the engagement with the threaded end of a commercial drain 250. In the proximity of the bottom circumference, another hole 459 is in communication with sleeve 459A for the connection with a pipe (not shown) for draining the water which might flow from the recovery waste pipe, as previously explained.

**[00150]** The assembly of the just described system 120 is very simple since it requires the interlock between the pin 610 together with the relative control 611 and the plug 800 with the insertion of a gasket in a completely conventional way. The bushing 73 is fixed through screwing inside the drain 250 with the insertion of the strainer 70 and the relative seal gasket on the bottom of the sink A. At this point, the pin 610 as previously arranged can be reversibly inserted in the drain 250 so that its end portion 613 exceeds the same drain. The diverting means 280 are fitted on the first portion 451 of the waste pipe 450 with the insertion of conventional gaskets in the suitable seats according to what already explained also with reference to the previous systems. Subsequently, the second portion 452 is screwed on the first portion 451 and the drain 250 with the pin 610 and the plug 800 is screwed on the ring nut 458 of the second portion 452.

**[00151]** The operation of the system 120 substantially occurs as previously described. Note that the end 613 of the pin 610 for activating the rotation of the diverting means



280 exceeds the drain 250 to insert itself, through a shape coupling in the cavity of the first protrusion 283 of the same means. In turn the means engage on the same axis of the above said activating pin but on the opposite side on the pin 453 of the first portion 451 of the waste pipe 450 in a rotatable way. In other words, the diverting means have two axial engagements facing the opposite directions such that in a simple but efficient way from one side they receive the rotation impulse transmitted by the control element 611 and on the other side they are free to rotate about the pin of the waste pipe to select either the sewage waste pipe or the recovery waste pipe (figures 63, 64).

**[00152]** In figures 65-67, there is shown a system 121 similar to the one just described. In particular the present system differs from the previous one in that the diverting means 290 comprise only one hollow and axial protrusion 291 provided with a through hole (not shown in figure 66, 67). Furthermore, the cavity of such protrusions, as for the previous embodiment, is such that it can accommodate in a rotatable way a pin for the rotation of the waste pipe. Furthermore, in the foregoing, the bottom 292 of the means comprises a hole 293 for the recovery waste pipe and a hole 294 for the sewage waste pipe as well as a ramp 295 to prevent water stagnation.

**[00153]** The waste pipe 130 still comprises a first portion 131 and a second portion 132. The first portion 131 is the same as the first portion 451 previously described with reference to the system 120. Also the second portion is basically the same as the second portion of the system 120 and differs from the latter for the presence of a coaxial seat 133 with a hollow pin 134 for the rotation of the aforementioned diverting means 290. The hollow pin corresponds to the rotation pin described with reference for example to the system 120 and differs for the presence of an axial hole (not shown in the figures 66, 67) aligned with the hole of the protrusion 291 of the diverting means 290. Conversely, the seat 133 opens on the opposite side with respect to the pin 134 and that is on the side facing the recovery waste pipe 35 and the sewage pipe 30. This seat, too, has a hole (not shown in figures 66 and 67) in axis with the hole of the rotation pin. In fact, said seat has the function of accommodating an elastic element 509 such as a spring connected to a shaft P which passes through the holes respectively of the seat 133 and of the pin 291 of the second portion 132 of the waste pipe 130 as well as of the protrusion 291 of the rotation means 290. In particular, the shaft P comprises a first end P1 connected to said elastic element and a second end P2 hollow and protruding from said protrusion 291 towards the cavity of the diverting means 290. It is to note that the second end P2 has a cross section which locks precisely together with the cross section of the protrusion 291.

**[00154]** The control 610 of the diverting means 290 are the same as those described with reference to the system 120 and, therefore, have an end 613 which inserts itself with a shape coupling in the second end P2 of the shaft P, which, in turn, as previously said, inserts itself precisely in the protrusion 291 of the diverting means 290 so as to allow them to rotate.

**[00155]** From the foregoing, it is clear that both the assembly and the operation are substantially the same as for the previous system 120 with the difference that the rotation of the control 611 in order to select the recovery system activates the elastic element 509 which after a predefined period of time automatically will return the system 121 to the position of the sewage system.

**[00156]** The advantage of the two described last systems 120 and 121 mainly lies in the compactness of the water flow diverting means and of the respective waste pipe, as well as the simplicity of adaptability to a conventional drain with strainer and plug.

**[00157]** From the foregoing, it is apparent that prior art drawbacks outlined in the introduction of the present description have been overcome and at the same time important advantages have been achieved.

**[00158]** In fact, by means of a simple handy control located above the sink bottom it is possible to select a plurality of water waste pipes of the sink according to preferences or requirements.

**[00159]** Furthermore, all embodiments of the present invention make it possible to realize draining systems in a simple and functional way, thus ensuring low production costs, low maintenance and low risks of malfunctioning.

**[00160]** The draining systems herein described can undergo modifications and adaptations within the skilled in the art expertise, without anyway exiting from the protection field of the appended claims.

**[00161]** For example, the forms described and shown of each element constituting the draining systems can be modified according to specific requirements or preferences. Similarly, sizes and coupling, insertion, connection means can have a great number of solutions comprising, for example, threaded or counter threaded screwing means, quick snap or bayonet coupling. Moreover, among the elements there can be used watertight elements such as conventional gaskets for example of the O ring type or flat gaskets, such as O ring O6 gaskets (for example figure 47) at the base of the seat or rotation pin of the rotating disc so as to realize a seal in this point and reduce friction between the same components.

**[00162]** The control pins to activate the flow diverting means can have various forms and controls suitable for specific requirements. In particular, the pins and the corresponding diverting means described for each embodiment can be combined one with the other also in ways different from the one described and shown in the figures, but yet having in mind their function, their dimensions and possible modifications or adjustments entirely concerning the shape of the means associated to them.

**[00163]** Overflow systems can also be provided in those embodiments wherein they have not been shown or described.

**[00164]** Also materials can be of different kinds according to specific requirements or preferences. In fact, it is well known that the most used materials in the sector are plastic or metal, among plastic materials the most known are the PP, ABS and among metals stainless steel, brass and other chromed metals.

**[00165]** Seeger type rings can be provided in all the embodiments wherein the diverting means are constituted by a disc or rotating cylinder on a pin of the waste pipe.

## CLAIMS

1. Multiple draining system (1;100-121) for sinks and basins, comprising a drain (2; 200; 210; 220; 230; 240; 250; 290) provided with a first portion (20; 201; 211; 231; 241; 251; 291) fixed on the upper or inner surface (S) of a bottom (A) of a basin for collecting water in correspondence of a draining hole (F) of said basin, and a second portion (21; 202; 212; 222; 232; 242; 252; 292) protruding from the lower or outer surface of said bottom so as to tightly connect with a cylindrical waste pipe (3; 300; 340; 345; 360; 370; 380; 480; 530; 520; 590; 451; 130) for draining the basin water, said pipe extending about a rectilinear axis (X-X) and being provided with a primary waste pipe (30) for the sewage system and a secondary waste pipe 35 for the recovery system, wherein means (5,32-33 ;12,38 ;12,39; V; 500; 550; 560; 570; 583; 683; 630; 640; 650; 280; 290) for diverting wastewater flow are accommodated inside said waste pipe and are selectively activatable so as to discharge the water by means of said primary waste pipe or of said secondary waste pipe, characterized in that said diverting means (5,32-33; 12,38; 12,39; V;500; 550; 560; 570; 583; 683; 630; 640; 650; 280; 290) can be activated by means of a control (4; 13; L;13a; 611; 692) positioned above the level of the bottom (A) of the basin.
2. System (1;100-121) according to claim 1, wherein said control (4;13; L; 13a; 611; 692) is connected to a pin (6; 600; 601; 610; 620; 690) lying on the axis (X-X) of the pipe and provided with a first end (61;602;612;622;693) axially fixed to said control rotatably and coaxially to said first portion (20; 201; 211; 221; 231; 241; 251; 291) of the drain or said first end (606) is fixed on an axial pin (8b) of a closing plug (8) of the drain, the pin comprising a second end (65; 603; 607; 661; 613; 695) which engages said diverting means rotatably or in a liftable/lowerable way, or said control comprises an articulated pin with a first end protruding from the upper rim of said basin and a second end connected to said diverting means by means of an articulated lever mechanism (7).
3. System (1;100-121) according to claim 2, wherein said control comprises a gripping element consisting in a knob (13;13A;611) rotatable about the axis (X-X), liftable/lowerable along or parallel to the axis (X-X) or an annular flange (42) or a lever (L) provided with a cam (L1) rotatable on a plane vertical to said axis (X-X).
4. System (1;103) according to claim 1, 2 or 3, wherein said diverting means (5,3) comprise a gate device (50,51;32,33) which in turn comprises a first fixed wall (32) and provided with a first aperture (33), and a second movable wall (57) provided with

a second aperture (51), the second wall being rotatable so that alternatively the first and the second apertures are superimposable so as to let the water flow into the primary waste pipe (30) or are not superimposable thus closing the water flow into the primary waste pipe, wherein said first wall (32) is fixed on the inner wall of said waste pipe (3) lower with respect to said secondary pipe (35), and said second wall (57) radially and tightly overlaps said first wall and is rotatable by means of said rotating mechanism.

5. System (100;101;102) according to claim 1, 2 or 3, wherein said means (12,300) for diverting the flow of wastewater comprise a narrowing (301;330) of the waste pipe (300) positioned lower with respect to its secondary pipe (35), and a plug (12) connected to the second end (607;603) of the pin (600;601) of said lifting/lowering mechanism so that it can be lifted or lowered to achieve a reversible and tight stop against said narrowing.
6. System (104) according to claim 1, 2 or 3, wherein said waste pipe (340) comprises a primary waste pipe (30) and a secondary waste pipe (35) positioned crosswise to the axis (X-X) on the wall of said pipe at the same level and diametrically opposed, and wherein said diverting means comprise a ball valve (V) to direct wastewater alternatively to the primary or secondary waste pipe.
7. System (105-121) according to claim 1, 2 or 3, wherein said diverting means comprise a rotating element (500;550;560;572;583;683;650;640;630;280;290) which in turn comprises a bottom provided with a seat (501;508;568;586;690;654;646;635) for a rotating engagement on a pin (341;576;587;483;537;596;528;453) of the waste pipe (340;345;360;370;380;480;530;520;590;451;130), and at least an aperture (506;551;552;565;566;W,W1;W2;687;631;657;643;285;293) for the flow of wastewater from the drain to the waste pipe, the waste pipe (340;345;360;370;380;480;530;520;590;451;130) comprising a plurality of holes for the sewage or recovery discharge of wastewater.
8. System (105-112;115) according to claim 7, wherein said rotating element is a cylinder (500; 550; 560; 572; 583; 683) comprising at least a hole (506; 551; 552; 565; 566; W1; W2; 687) formed on the lateral wall communicating with a sewage waste pipe (30) or recovery waste pipe (35).
9. System (111;112) according to claim 8, wherein said rotating mechanism comprises a rotating cylinder (550;560) provided with two apertures (551;552;565;566) arranged on its lateral wall on two different crosswise planes along said axis (X-X) and said waste pipe (345;360) comprise a primary waste pipe

(30) and a secondary waste pipe (35) positioned at two different points along said axis (X-X).

10. System (111) according to claim 9, wherein the two apertures (551;552) of said rotating cylinder (550) are positioned at 90° one from the other and said primary waste pipe (30) and said secondary waste pipe (35) are positioned at 90° one from the other.
11. System (112) according to claim 9, wherein the two apertures (565;566) of said rotating cylinder (560) are positioned axially aligned and said primary waste pipe (30) and said secondary waste pipe (35) are positioned on two crosswise planes axially staggered and misaligned, preferably diametrically opposed, and each having its axis orthogonal to the axis (X-X) of the pipe (361).
12. System (113) according to any of the claims from 1 to 3 and to claim 7, wherein said diverting means (570) comprise a first truncated cone-shaped element (571) which fits on a second truncated cone-shaped element (572), both hollow and provided with respective closed minor bases (574) for rotation coupling along the axis (X-X) and open major bases (573) facing said primary waste pipe (30), the lateral wall of both first and second elements comprising an aperture (W;W1) being superimposable thanks to the rotation of said first element on said second element for draining water into said primary waste pipe (30).
13. System (116;117;118) according to claims 1, 2, 3 or 7, wherein said diverting means (630;650) are a rotating disc having two circumferential holes (631;657) for the sewage waste pipe (30) or recovery waste pipe (35) in an alternative way and a central hole (634;655;689) for the engagement with a rotating pin (537;596) of the waste pipe (530;590), and wherein the waste pipe comprises a first cylindrical portion (531;591) and a second discoid portion (532), the second portion comprising a first surface (553;593) wherefrom an annular band raises to guide the insertion of the rotating disc and besides comprising two holes (539;H1;H2) communicating respectively with said recovery waste pipe (35) and said sewage waste pipe (30) and such to cooperate alternatively with the holes of the rotating disc.
14. System (115;116;117) according to any of the claims 7, 8 and 13 further comprising first engaging elements (691;636) integral with said seat (690;635) and adapted to cooperate with second engaging elements (400;421;423) integral with said control (621;692) to rotatably activate said means (683;630) for diverting water.
15. System (115;116;117) according to claim 14, wherein said first elements

(691;636) are a plurality of walls spaced by spaces (692;637) for the precise insertion of said second elements formed by feet (402;422;426).

16. System (116;117;118) according to any of the claims from 13 to 15, wherein said disc of said diverting means (630;650) comprises at least a further through hole (638;658) connected with a corresponding tower (637;659) in order to drain water into the sewage waste pipe should water from the recovery waste pipe (35) go back towards the drain.
17. System (118;121) according to any of the claims from 1 to 3, 7, 13 and 16, wherein the bottom of the waste pipe (590;520;450;130) comprises an inclined plane (593A;526A;287;295) with an incline from the recovery waste pipe (35) to the sewage waste pipe (30).
18. System (119-121) according to any of the claims from 1 to 3, 7 and 17, wherein said means (640;280;290) for diverting the water flow have the shape of a cylindrical container having a circular bottom (641;281;292) and an annular lateral wall (642;282), the bottom inner surface having a ramp-shaped portion (648;287;295) inclined towards two holes (643;293;285) each connected either with the recovery waste pipe (35) or with the sewage waste pipe(30).
19. System (1;100-121) according to any of the claims from 1 to 18, comprising stop means (18;19;695,487) to stop the rotation of the means (5;32-33; 12,38; 12,39; V; 500; 550; 560; 570; 583; 683; 630; 640; 650; 280; 290) for diverting water flow with respect to the waste pipe (3;300;340;345;360;370;380;480;530;520;590;451;130).
20. System (115;116;117;118) according to claim 19, wherein said stop means comprise two circumferential steps (695) formed on the inner wall of a cylindrical sleeve (690;635) in continuity with the central hole (634;655;689) of the diverting means, said steps cooperate with a radial tooth (487) formed on the outer surface of the base of said pin (483) of the waste pipe.
21. System (120;121) according to any of the claims 1-3,7,17-19, wherein said waste pipe (450;130) comprises a first portion (451;131) connected with said sewage waste pipe (30) and said recovery waste pipe (35) and a second lid-shaped portion (452;132) having a bottom (454) and a lateral wall (455), the bottom is perforated and provided with a ring nut (458) for fixing to a drain and provided with a sleeve (459A) for the connection with a supplementary waste pipe, while the lateral wall ends with a flange (456) for fixing to the first portion.
22. System (107;118;119;121) according to any of the claims 1-2,7,13,16-21,

wherein the bottom of the rotating cylinder (500) or the bottom (590;520;130) of the waste pipe is provided with a timer (509) for repositioning the rotating cylinder from the position of recovery system (35) to the position of the primary sewage system (30), said timer being controlled by means of a rotation of the rotating cylinder given by said control pin (610).



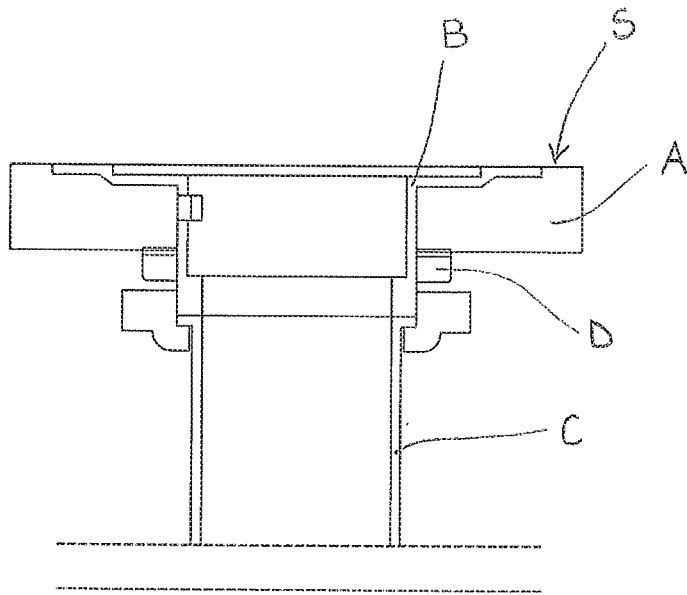

Fig. 1  
(Prior Art 1)

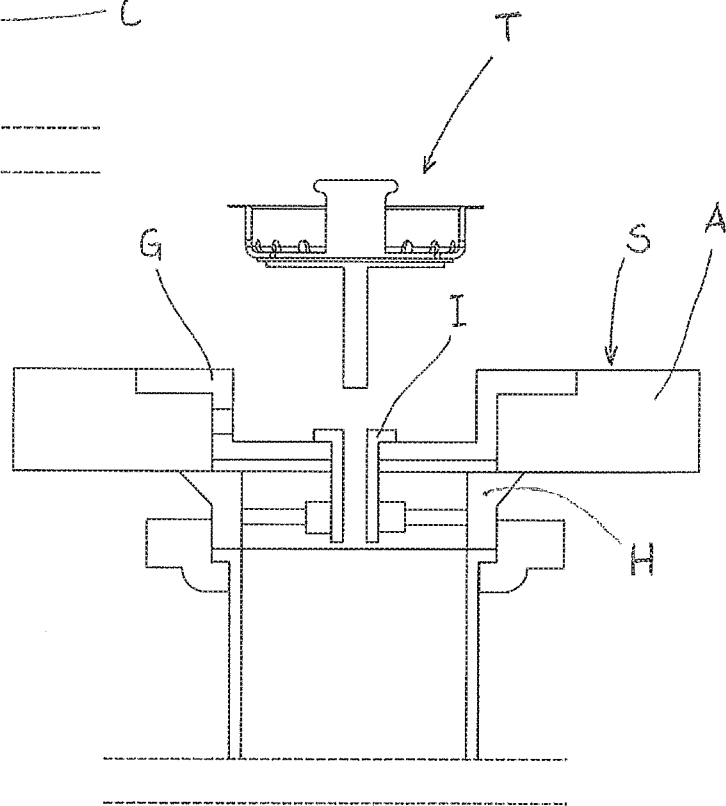

Fig. 2

(Prior Art 2)

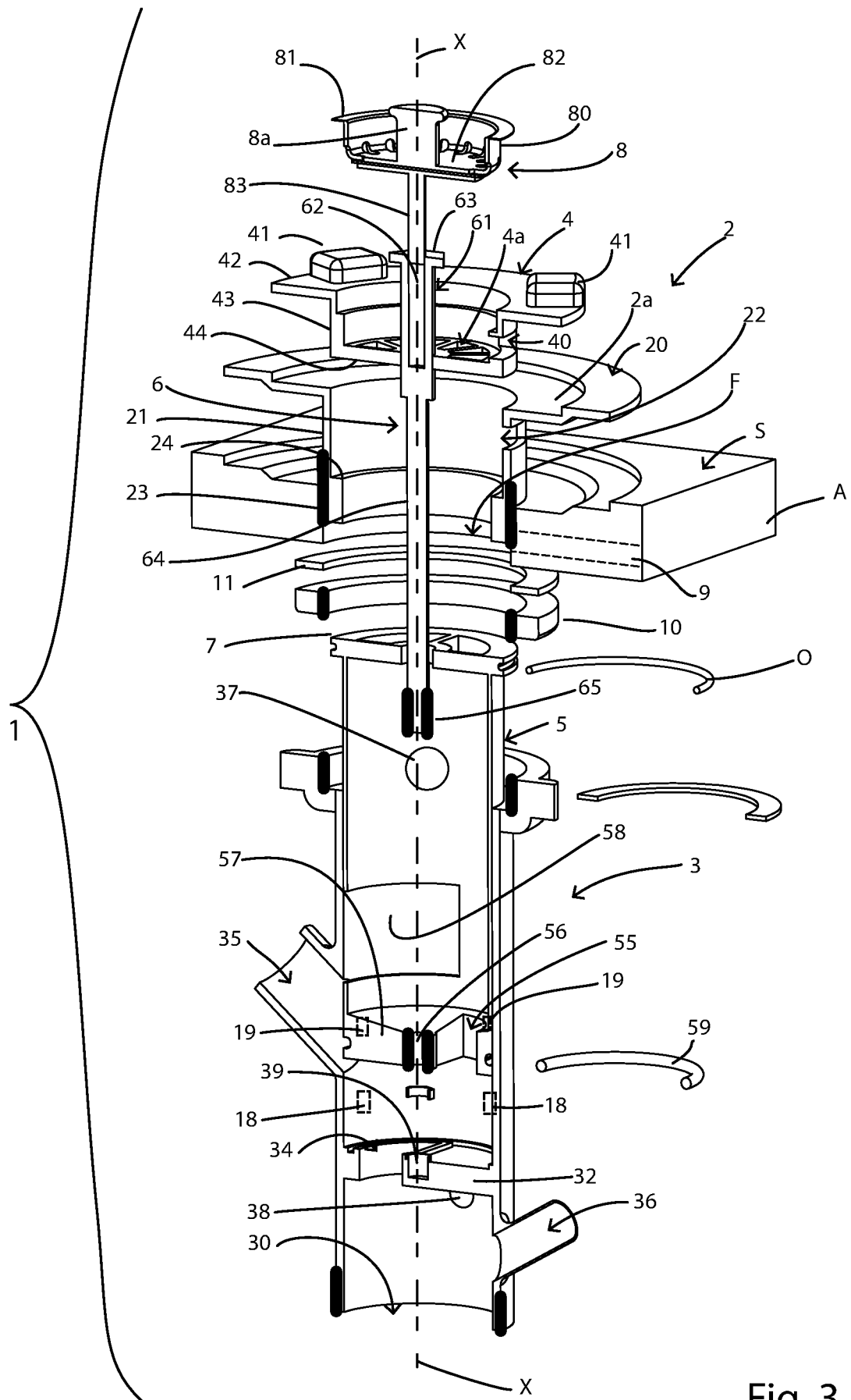

Fig. 3

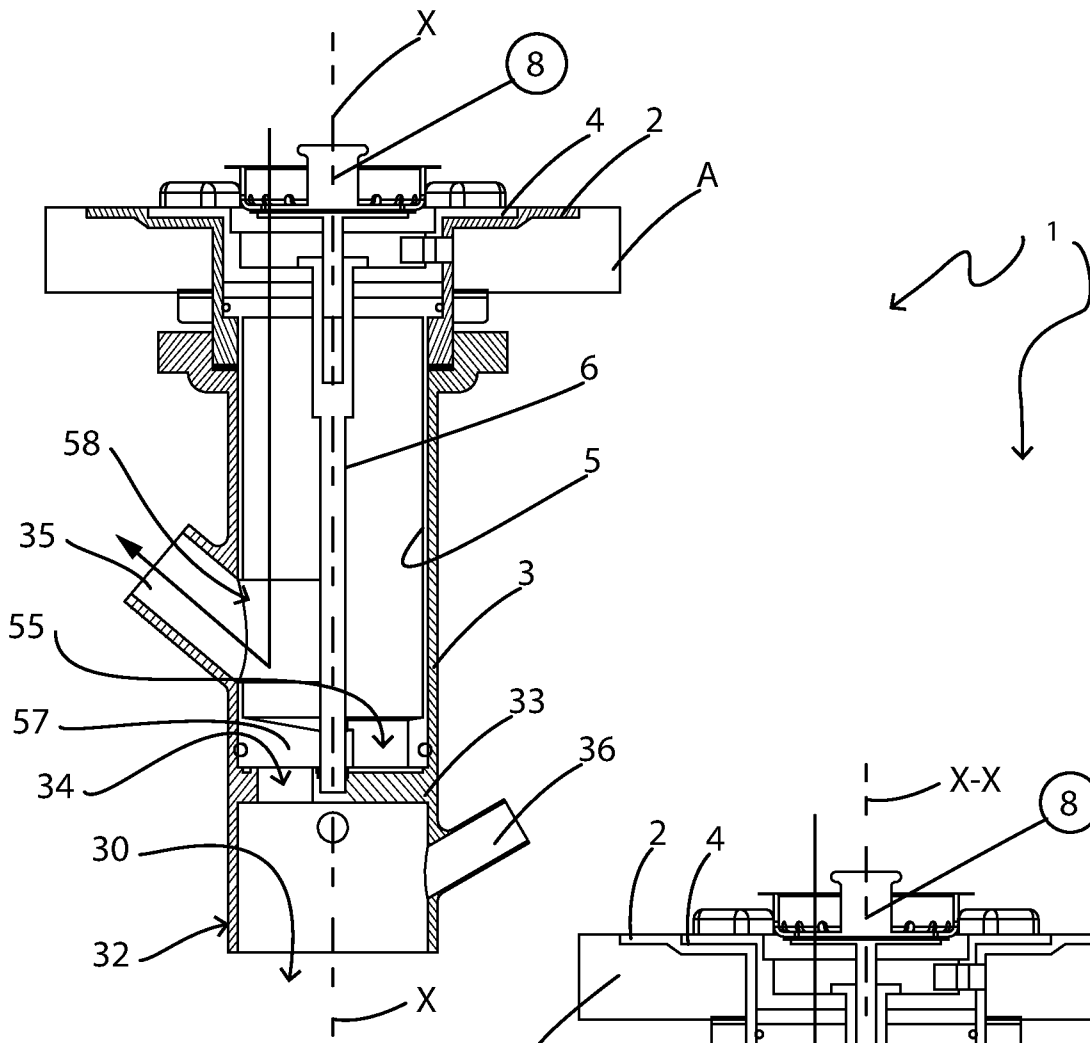

Fig. 4

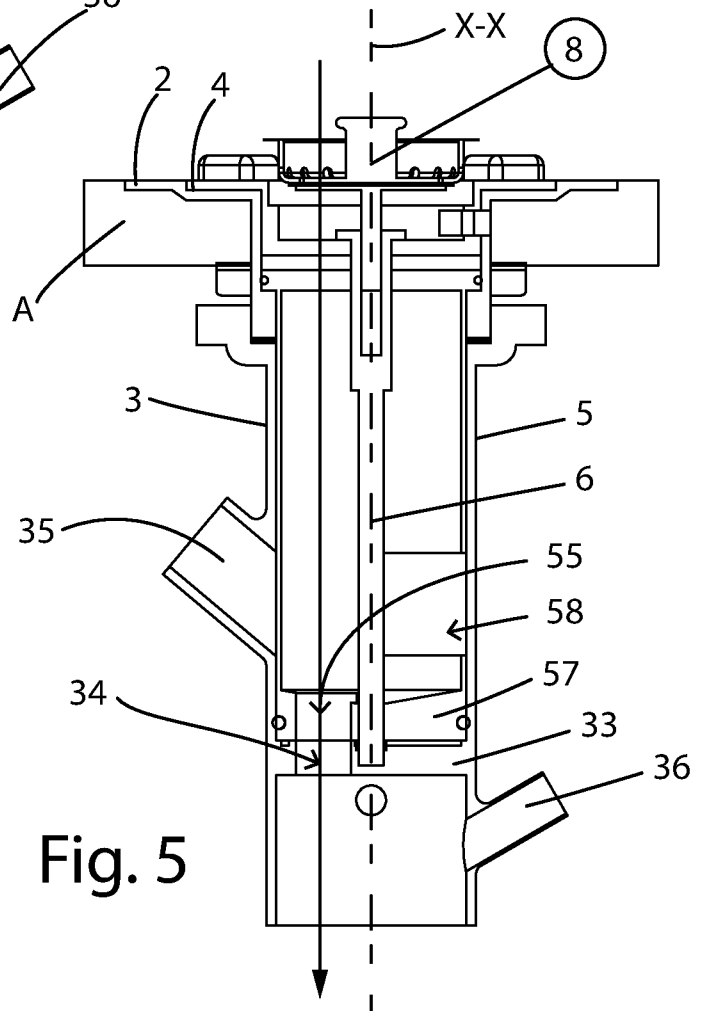

Fig. 5

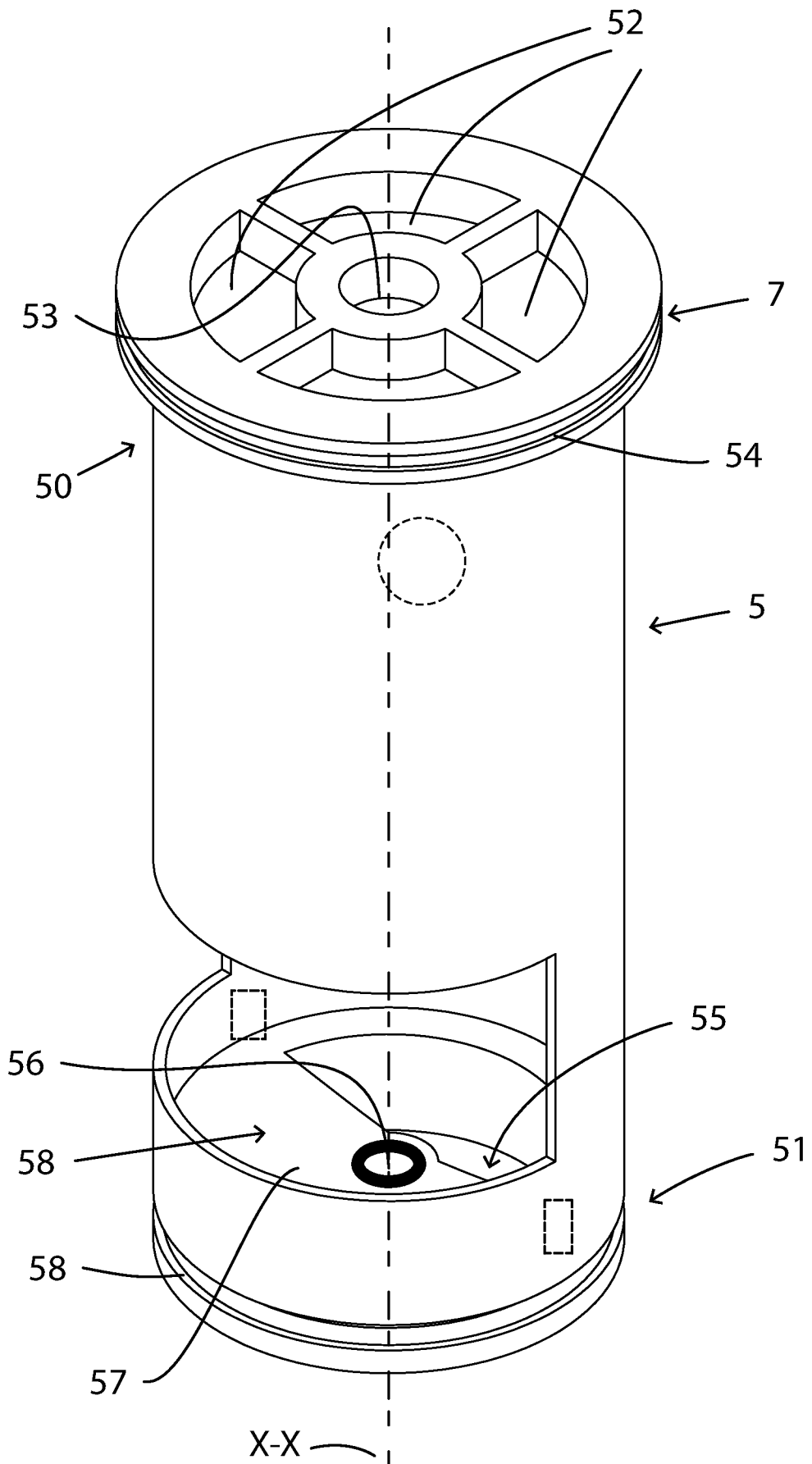

Fig. 6

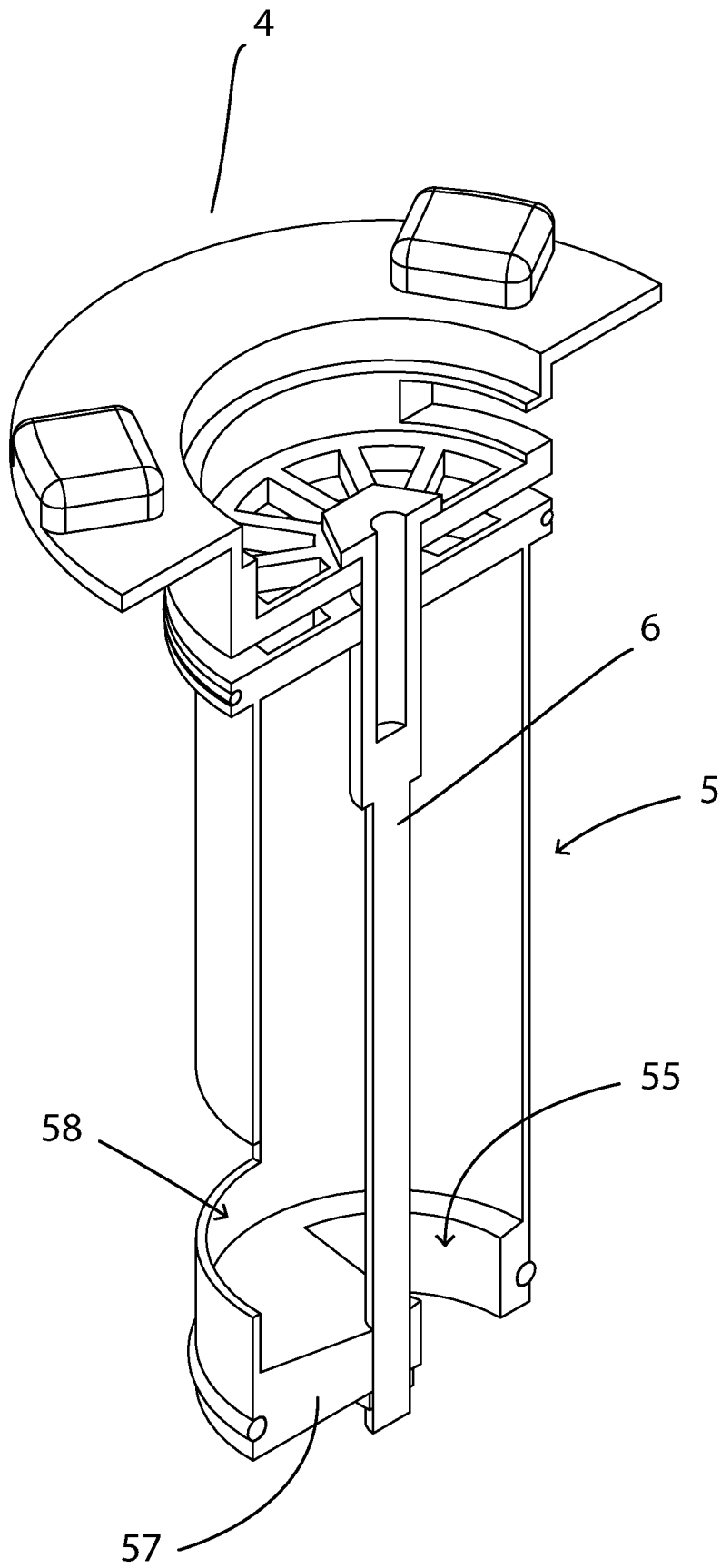

Fig. 7

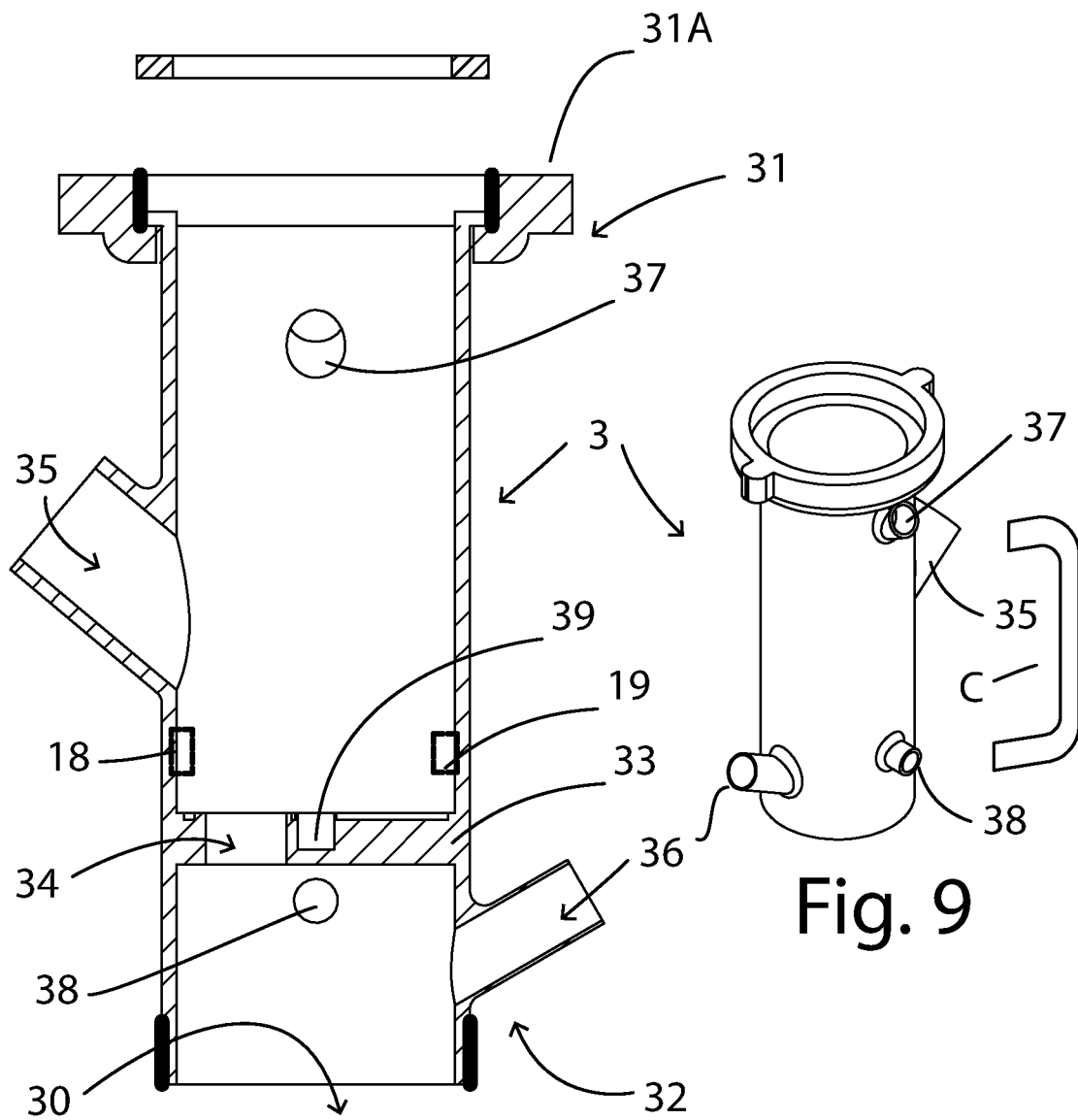

Fig. 8

Fig. 9

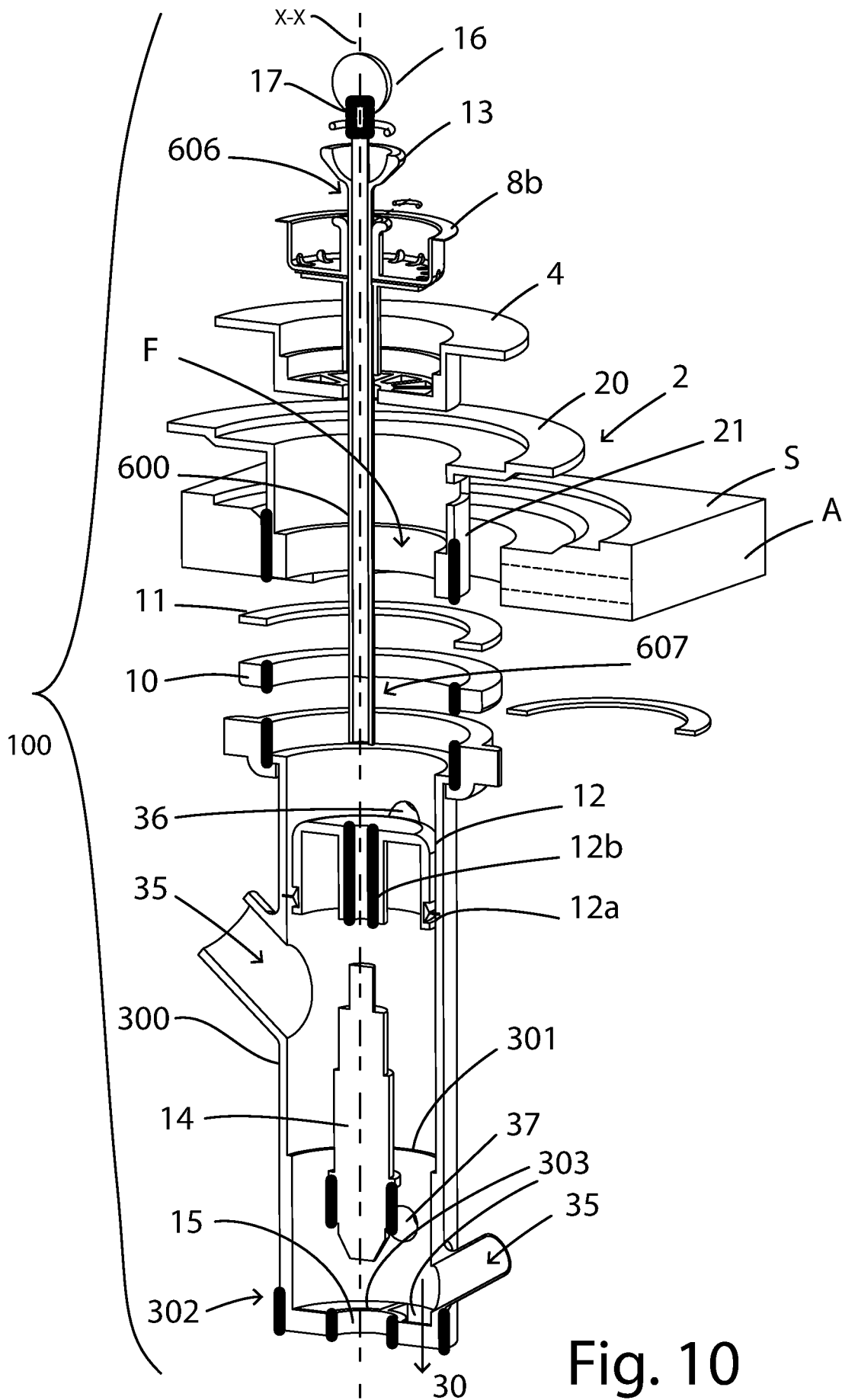

Fig. 10

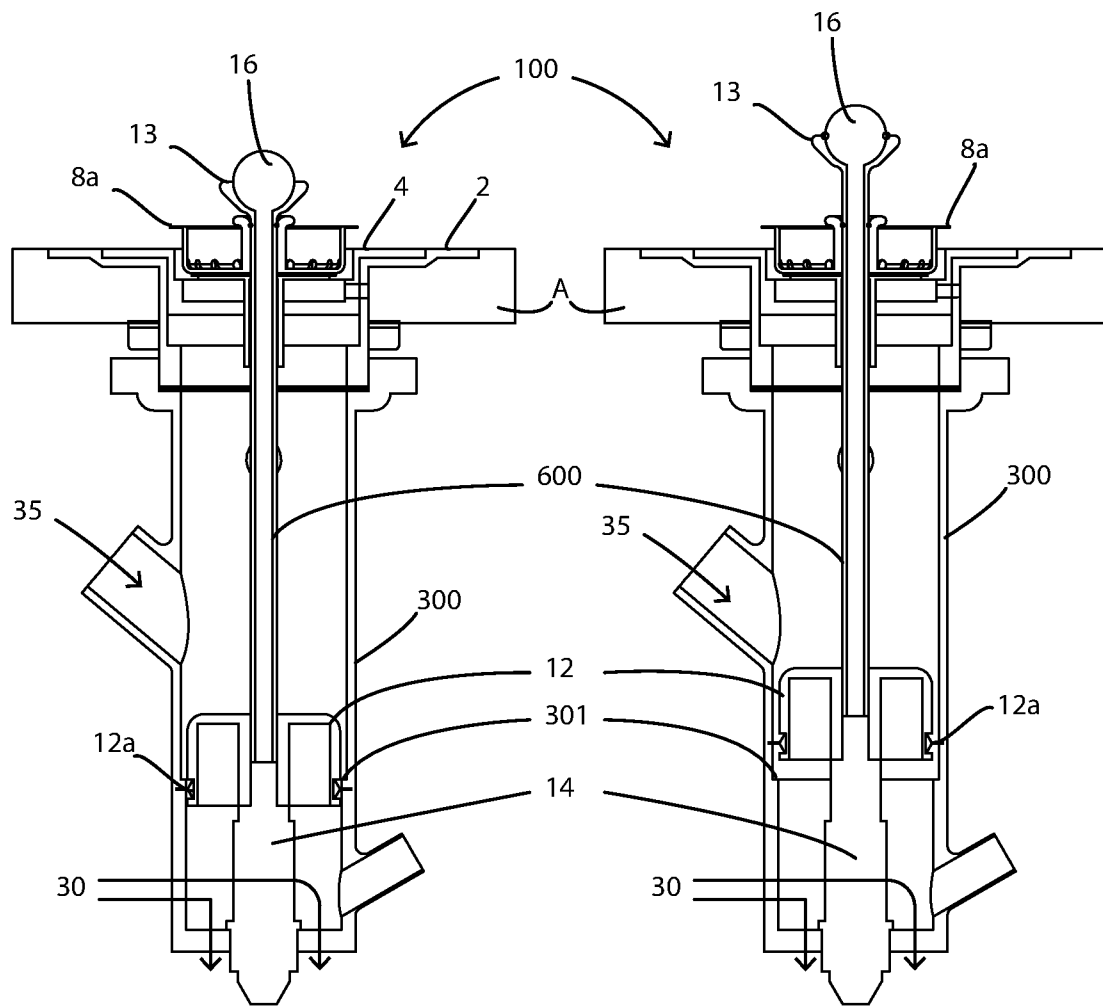
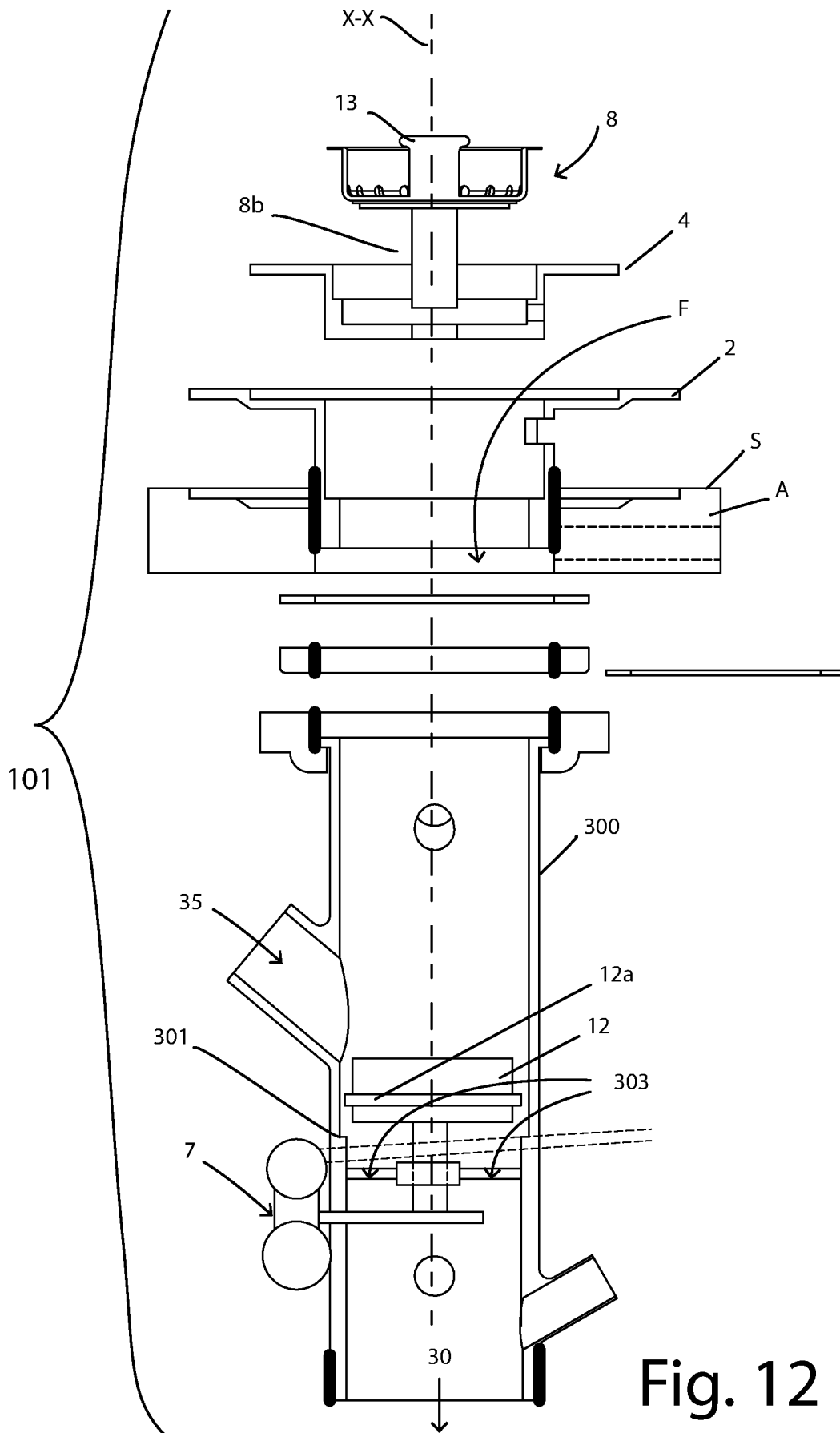

Fig. 11a

Fig. 11b





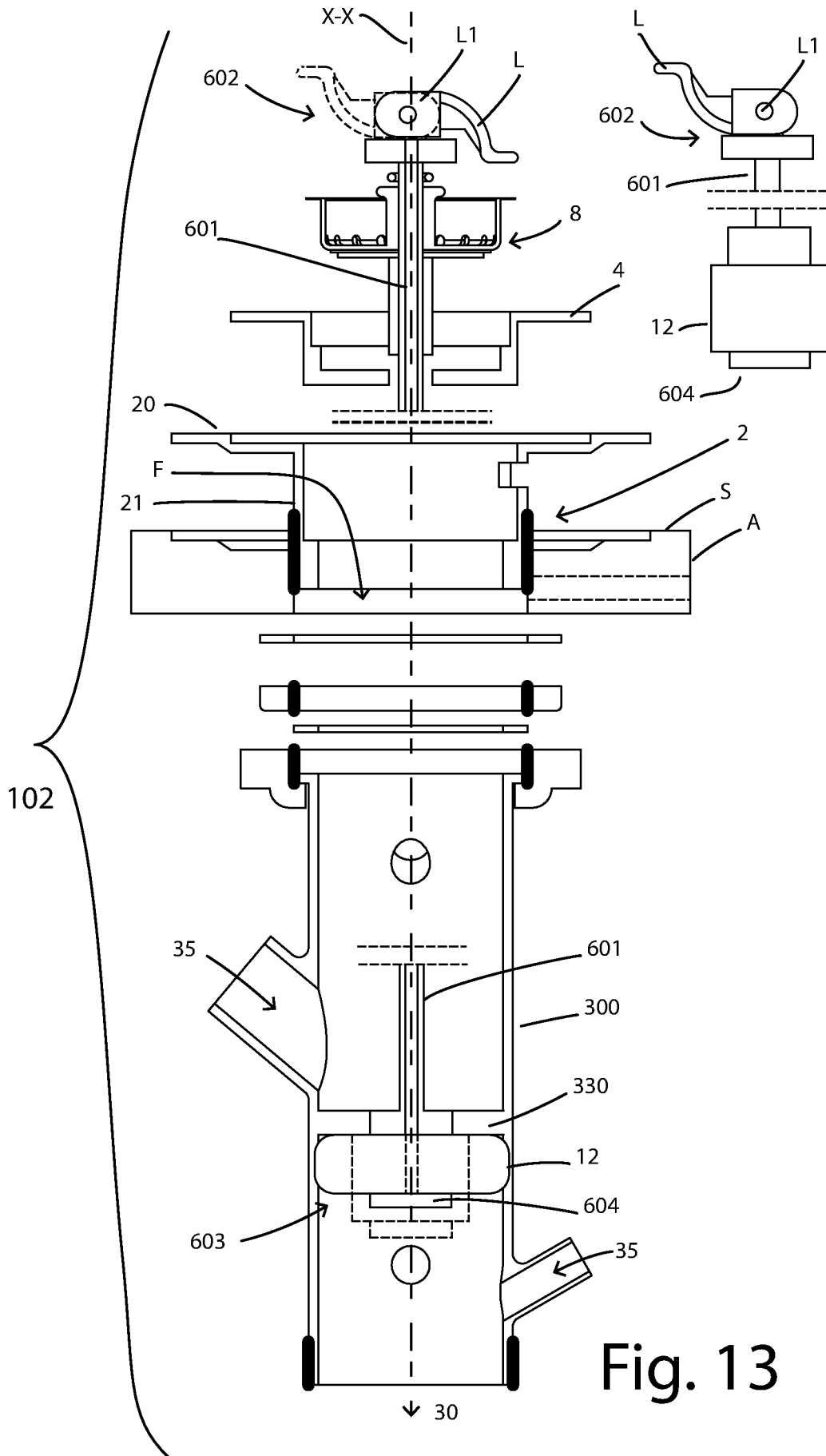

Fig. 13

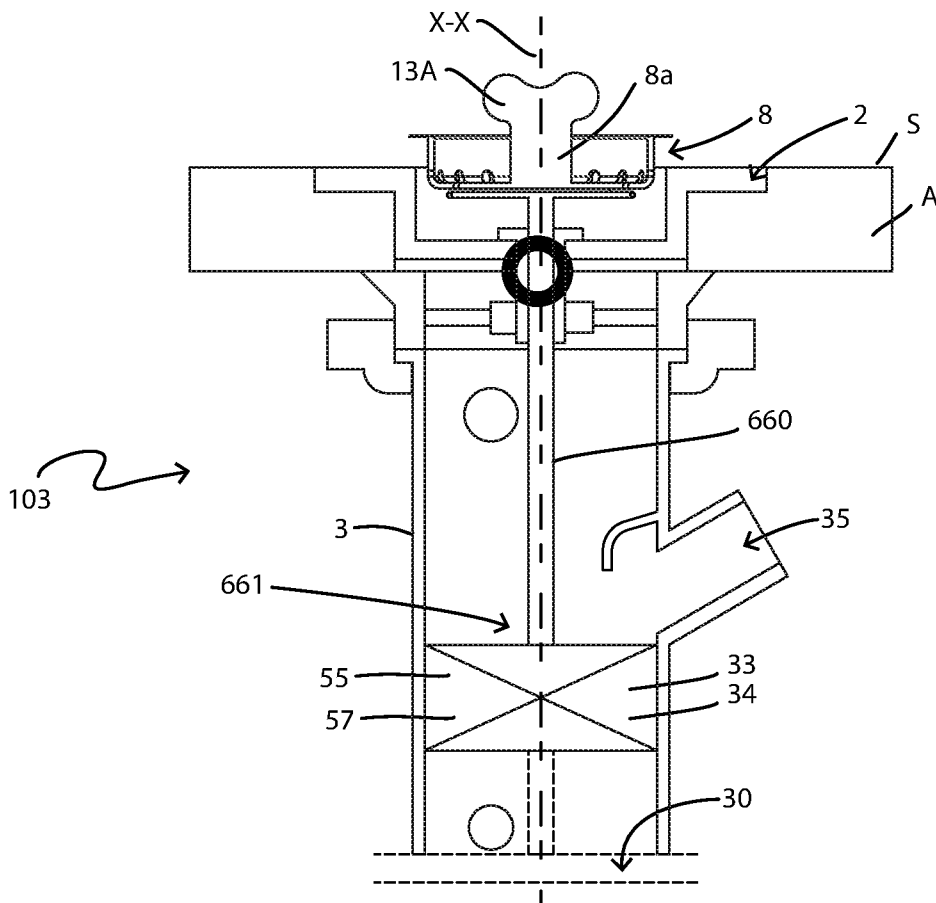

Fig. 14

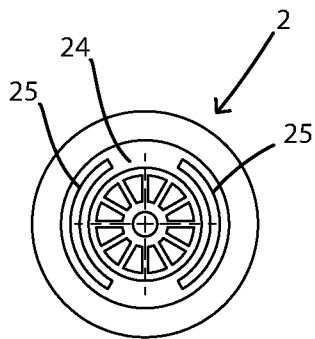

Fig. 15

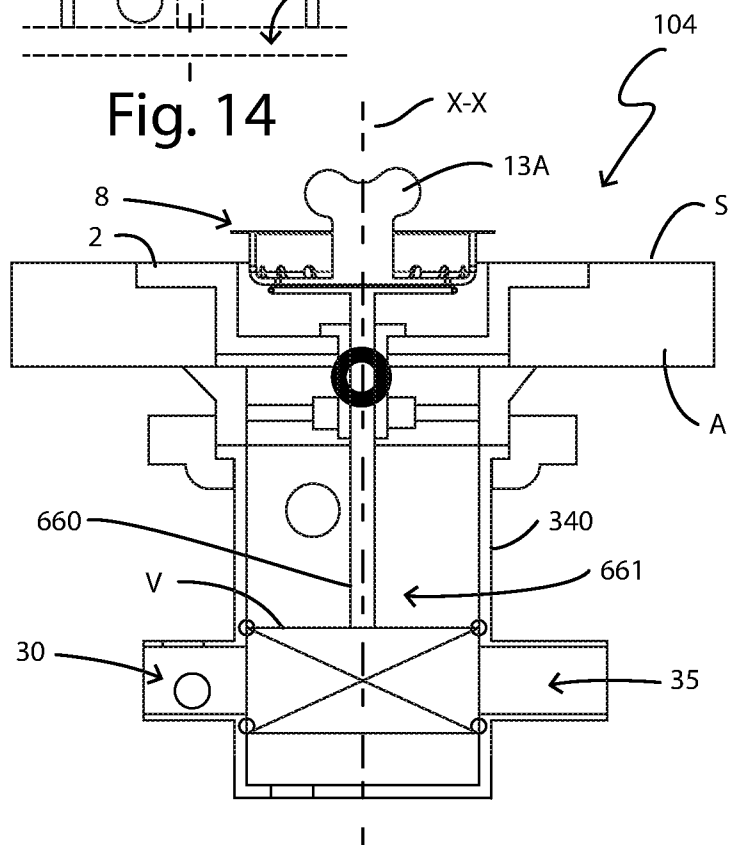
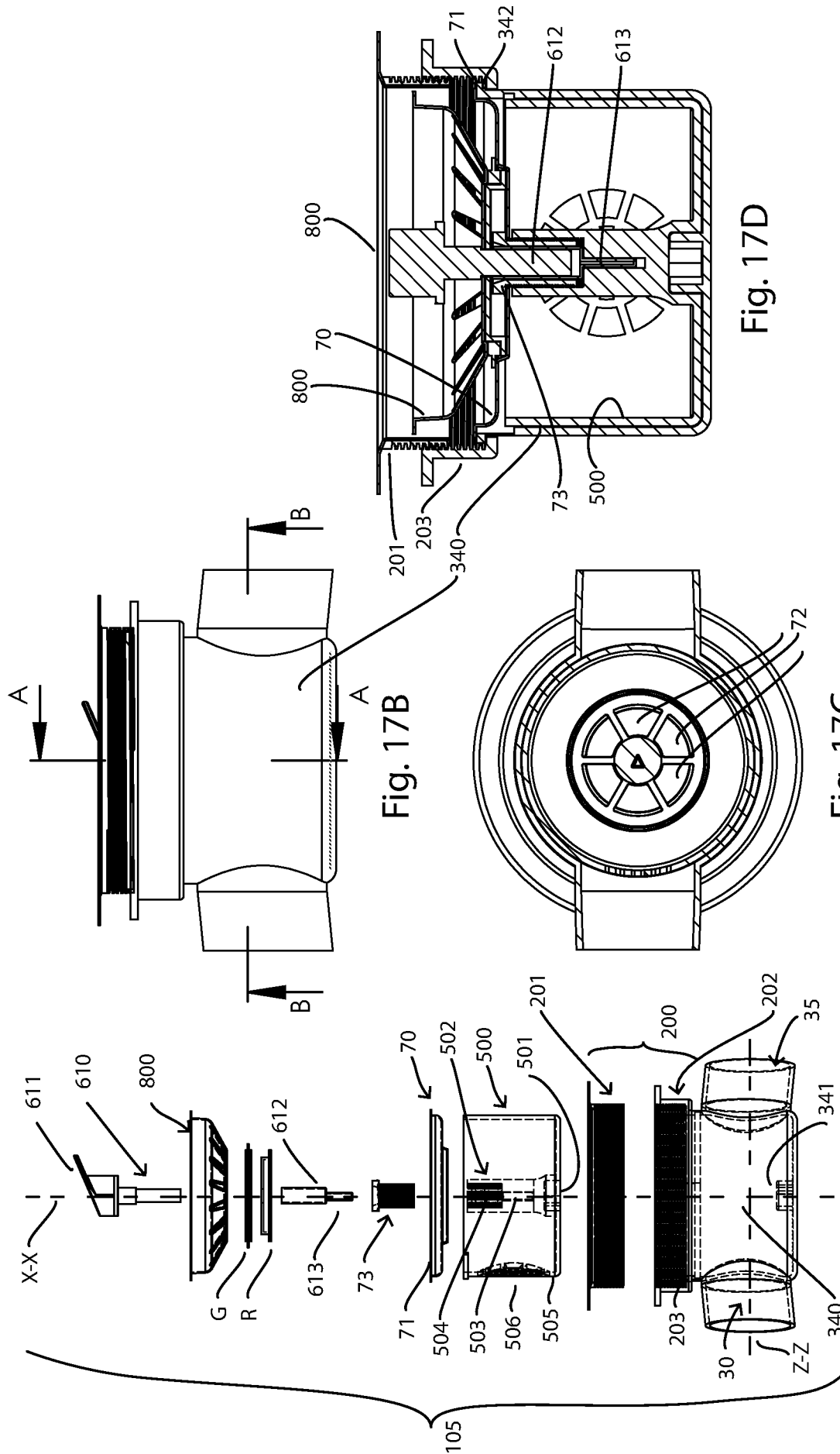

Fig. 16



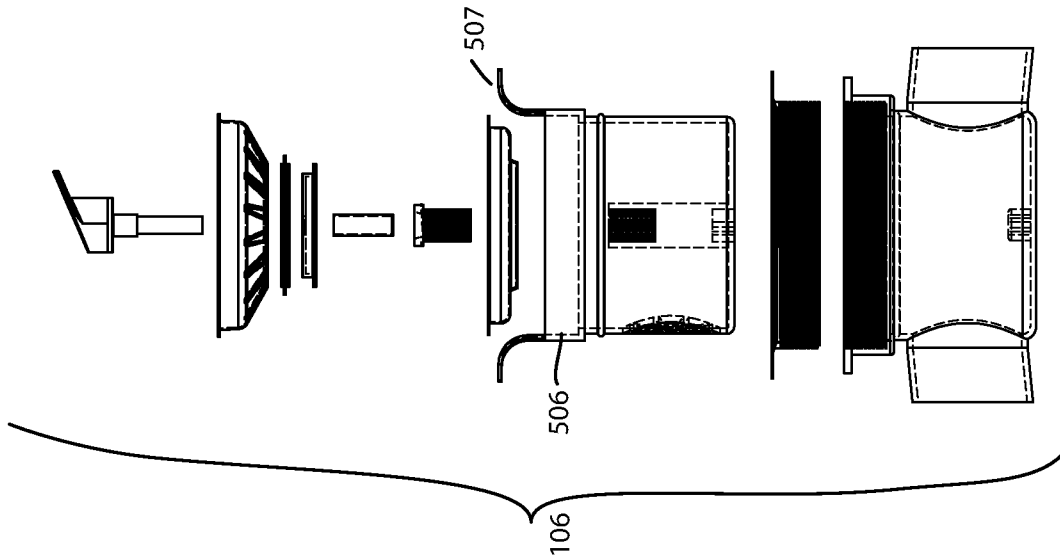

Fig. 18

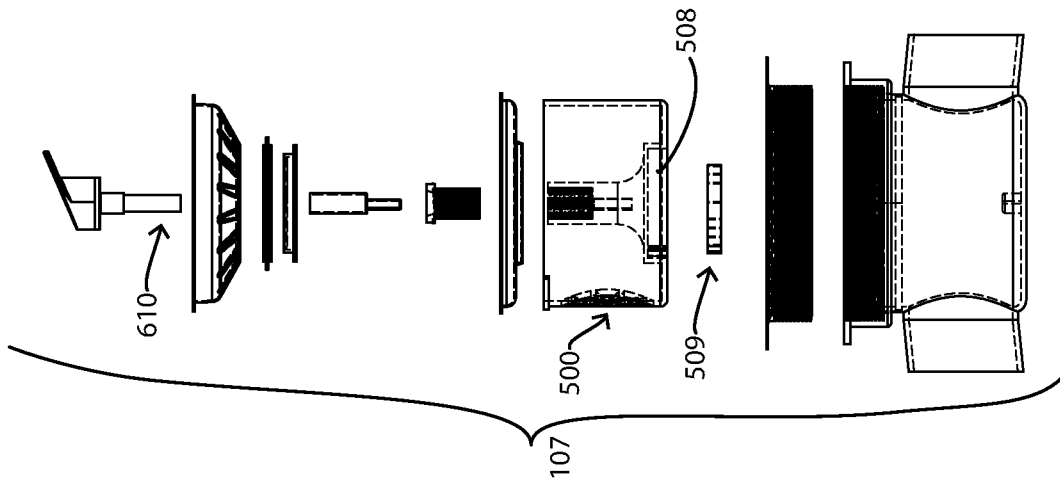

Fig. 19A

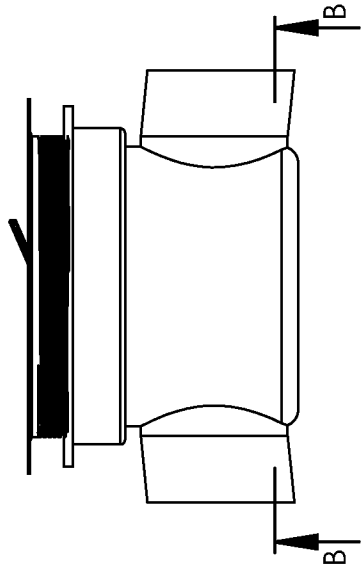

Fig. 19B

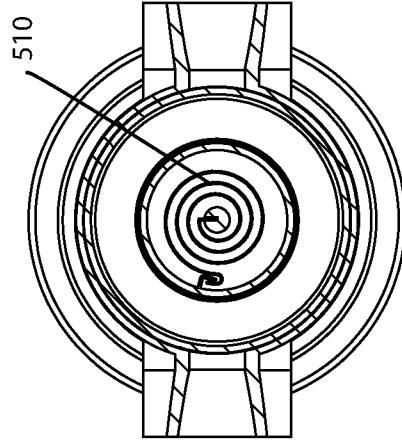
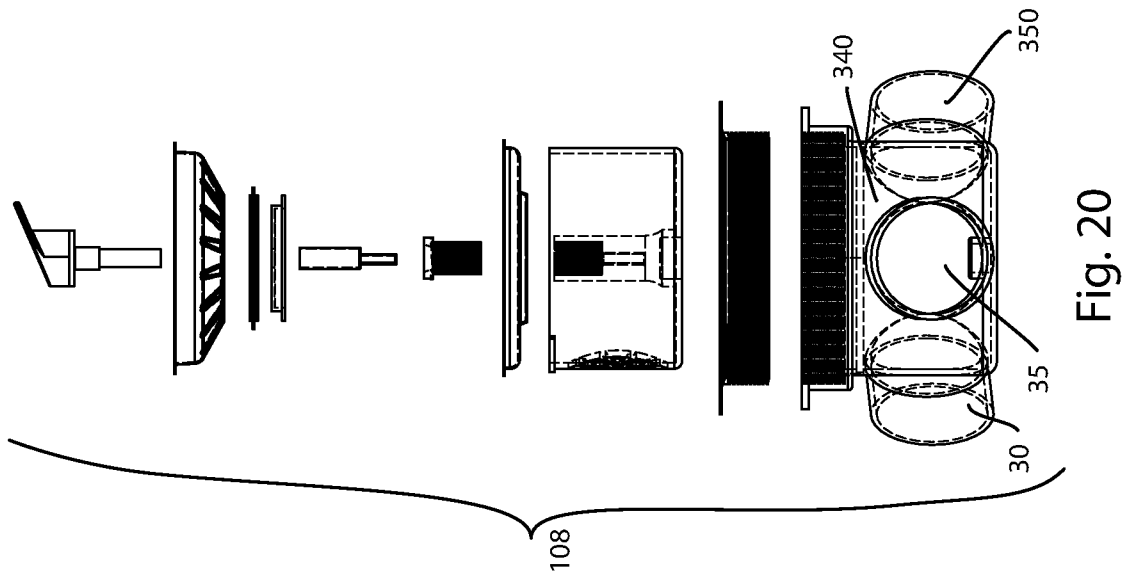
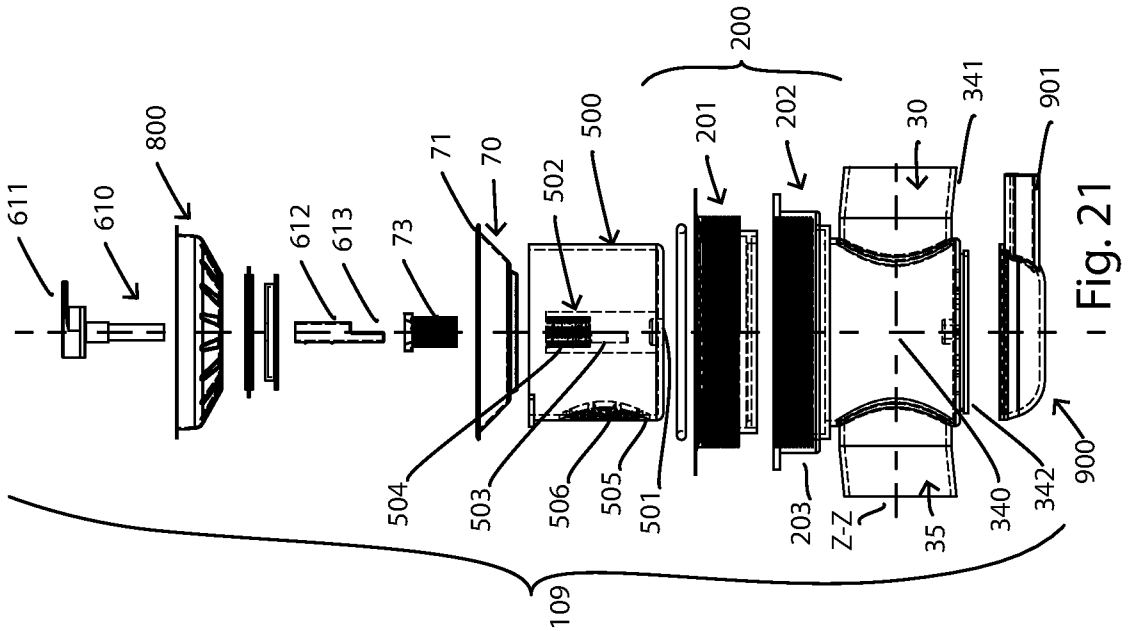
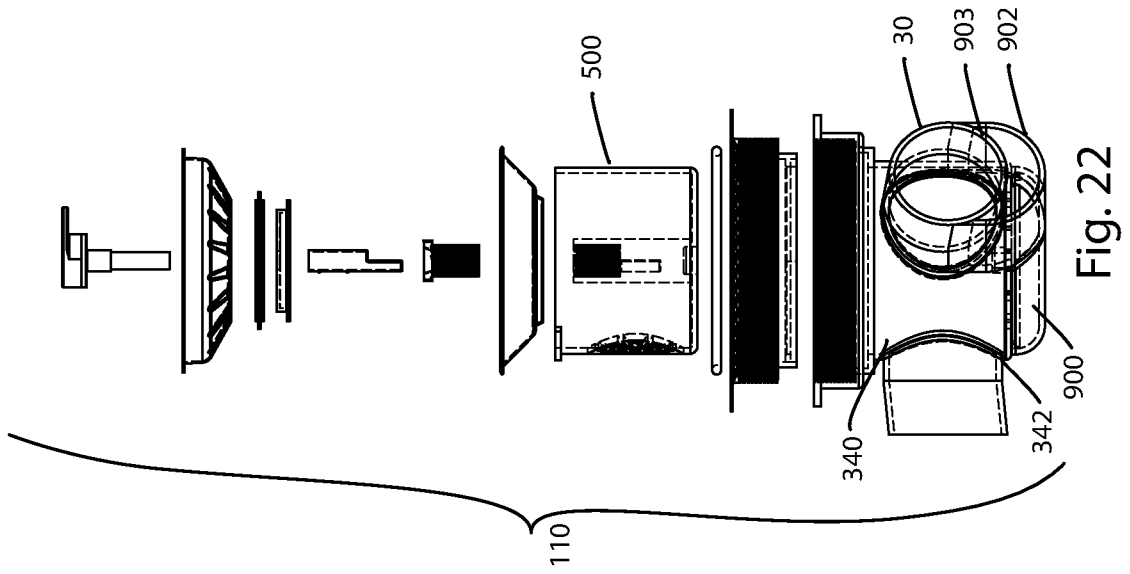

Fig. 19C



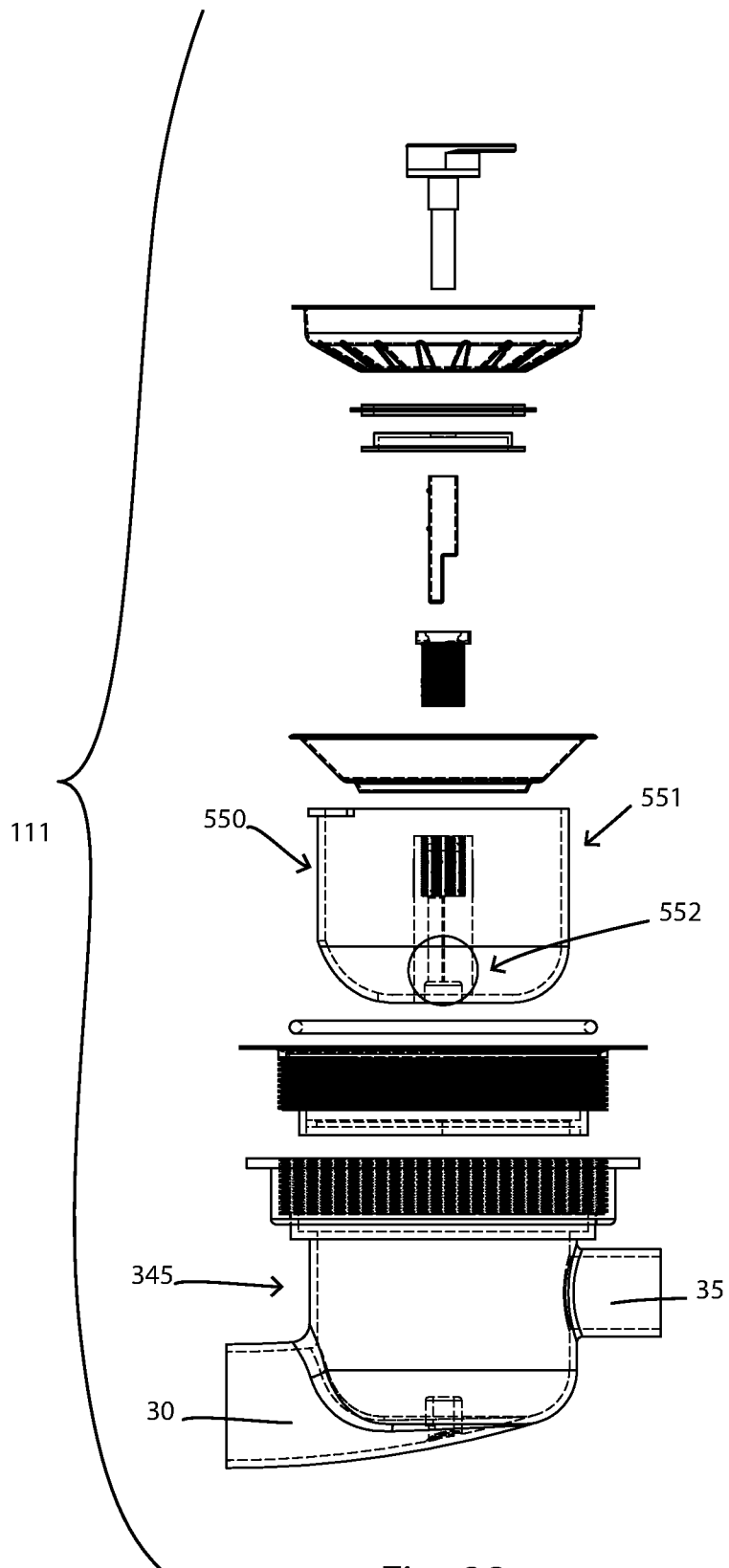

Fig. 23

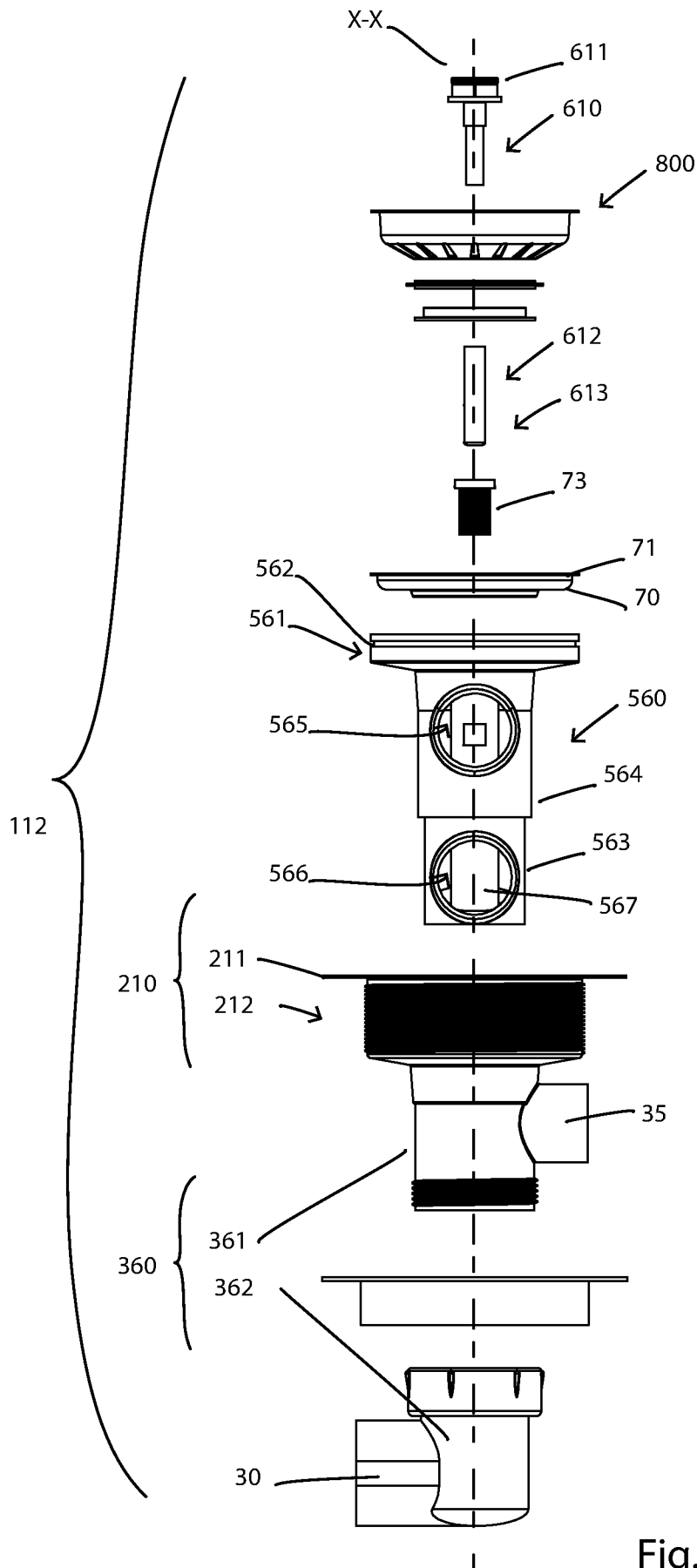

Fig. 24A



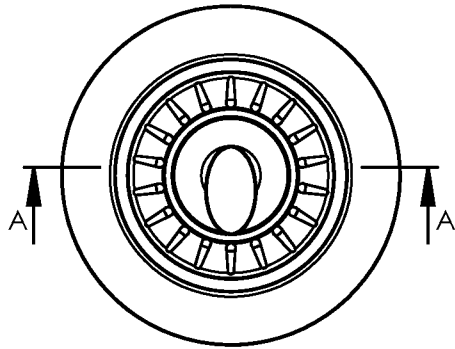

Fig. 24B

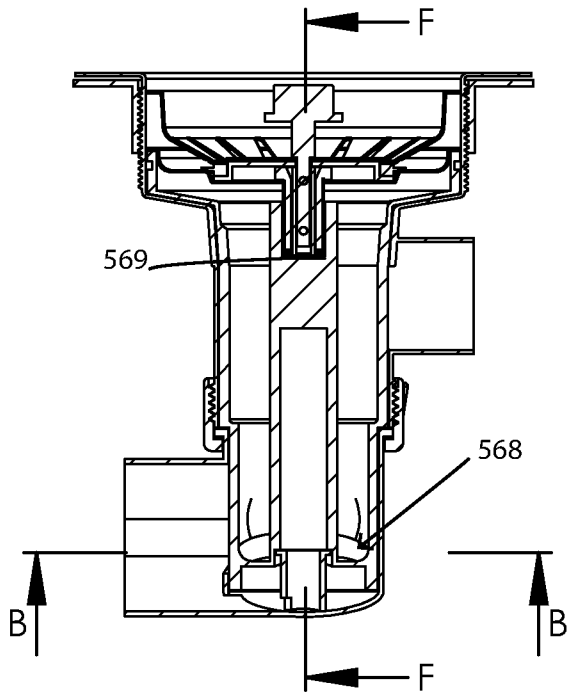

Fig. 24C

112

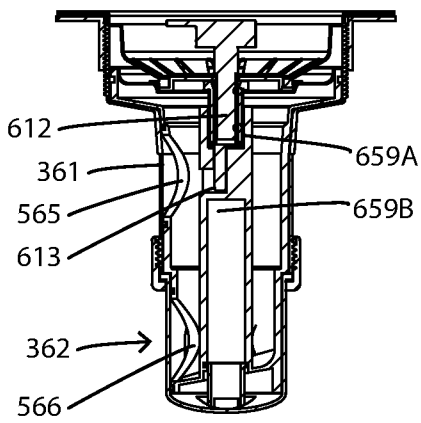

Fig. 24E

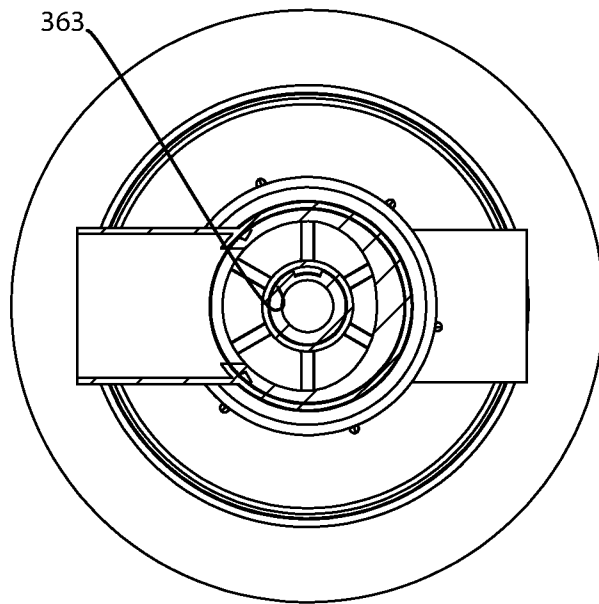

Fig. 24D

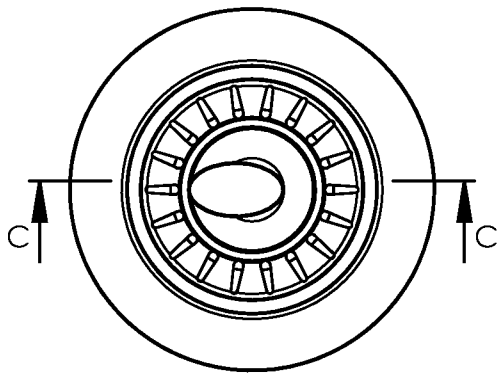

Fig. 24F

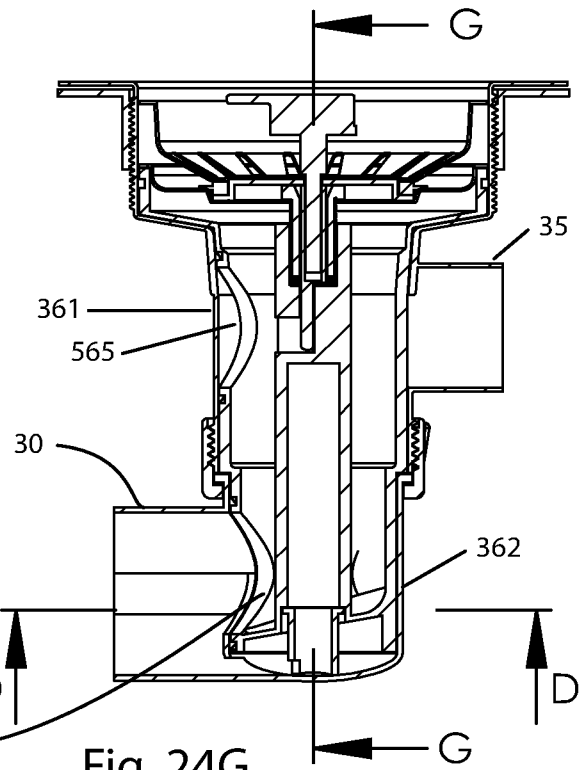

Fig. 24G

112

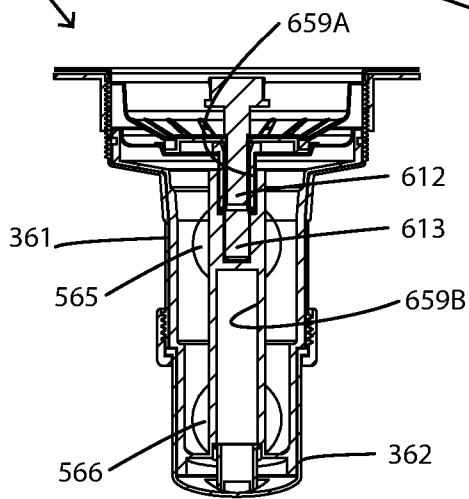

Fig. 24I

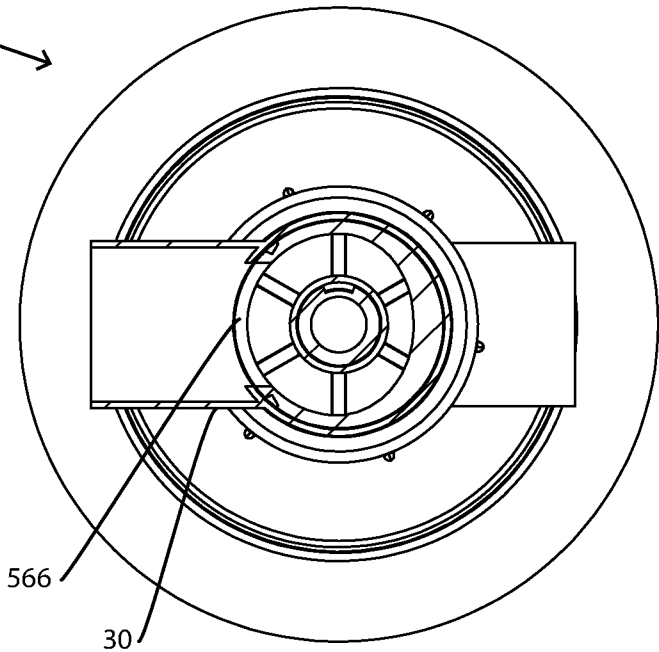

Fig. 24H

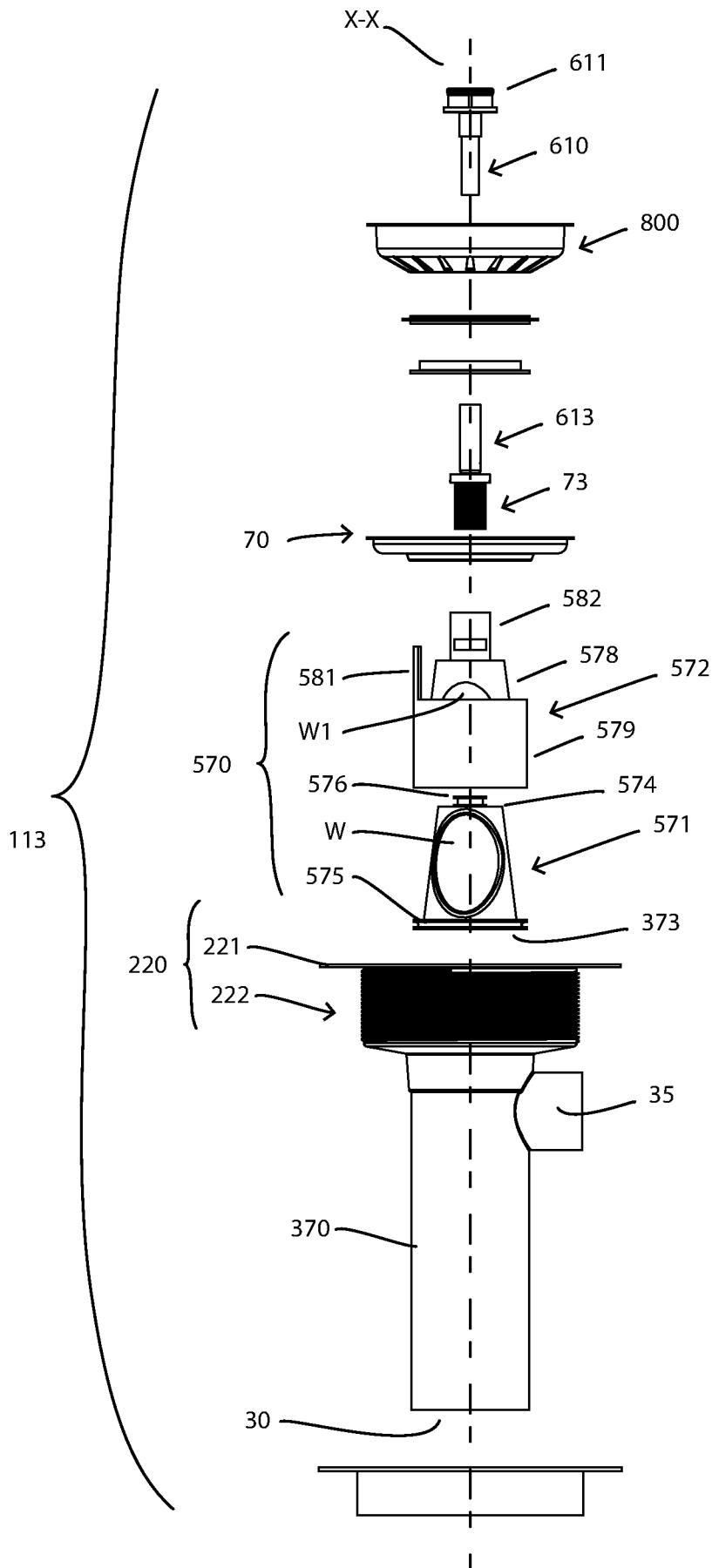
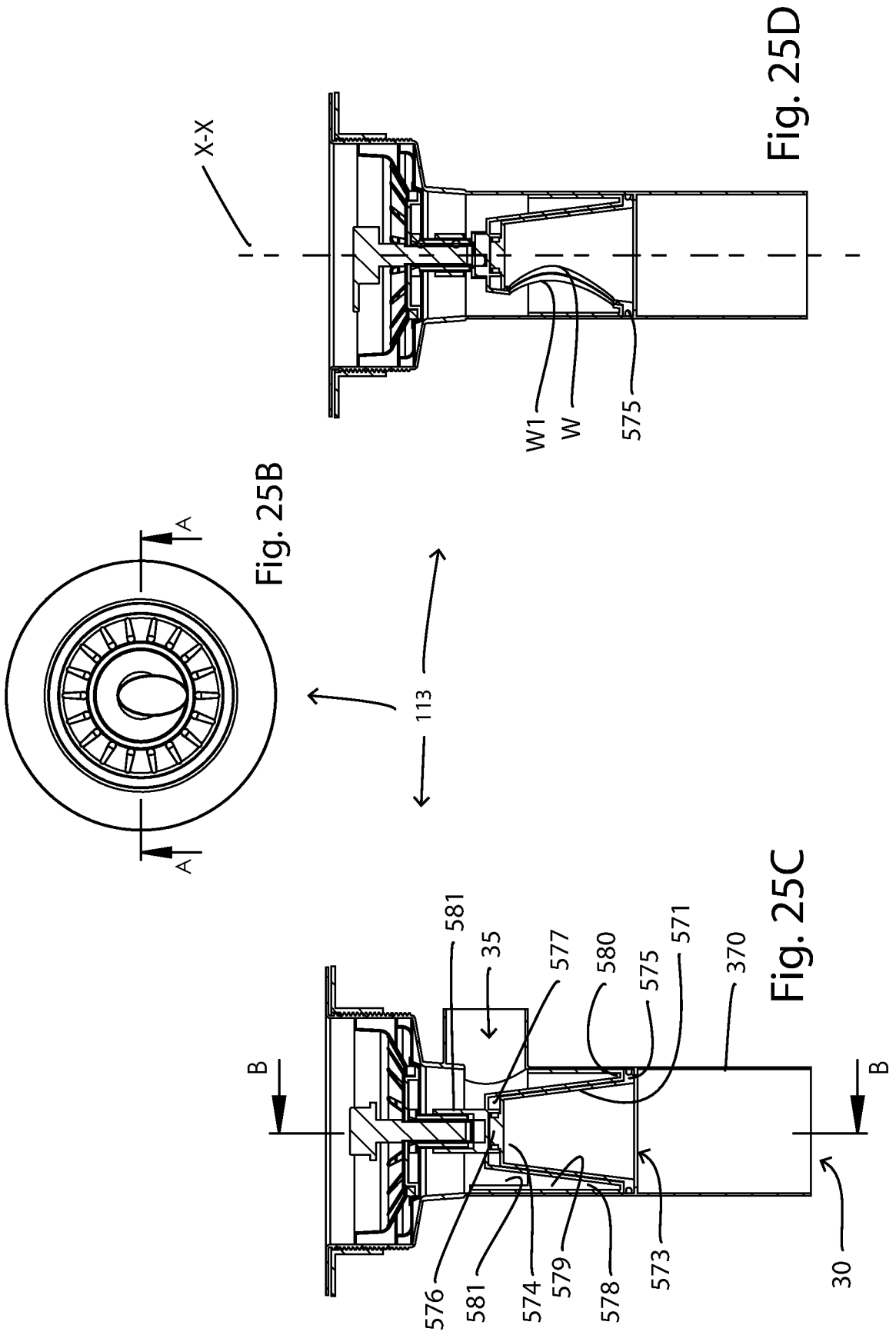

Fig. 25A



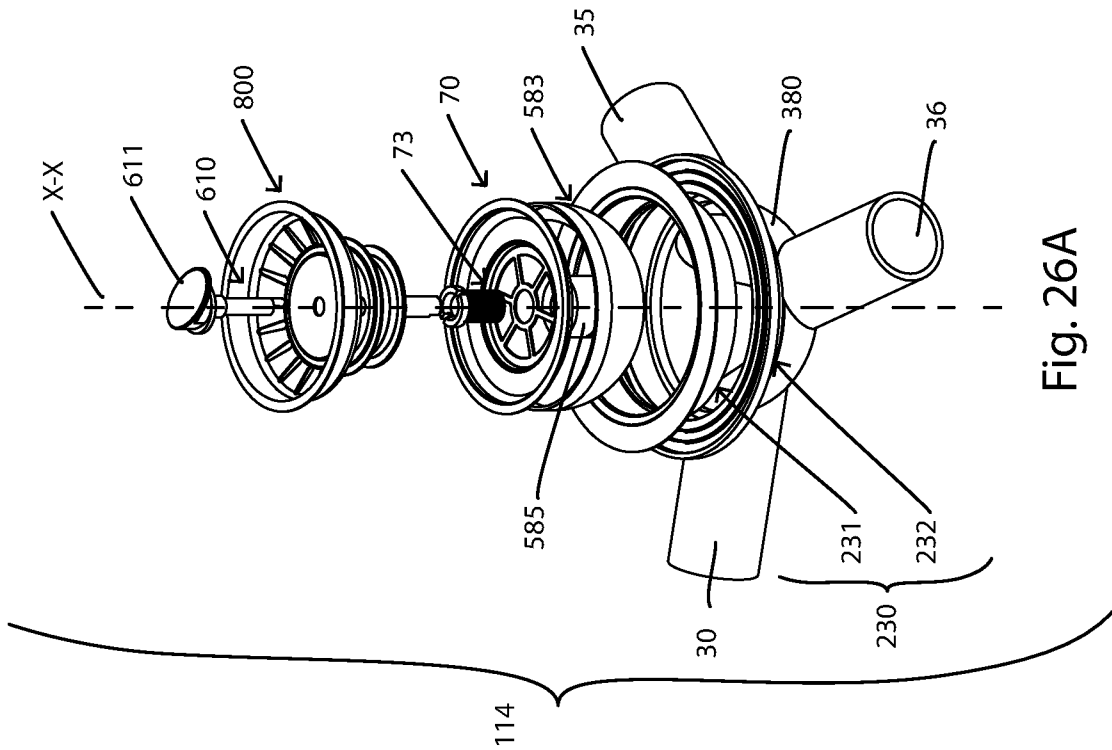

Fig. 26A

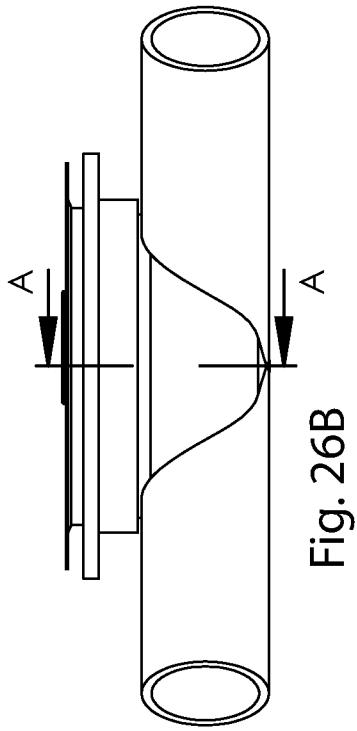

Fig. 26B

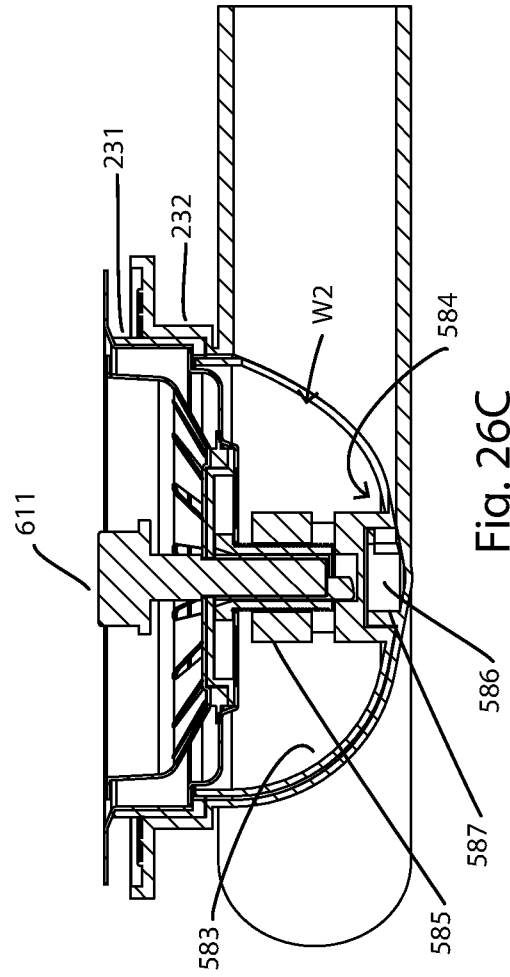

Fig. 26C

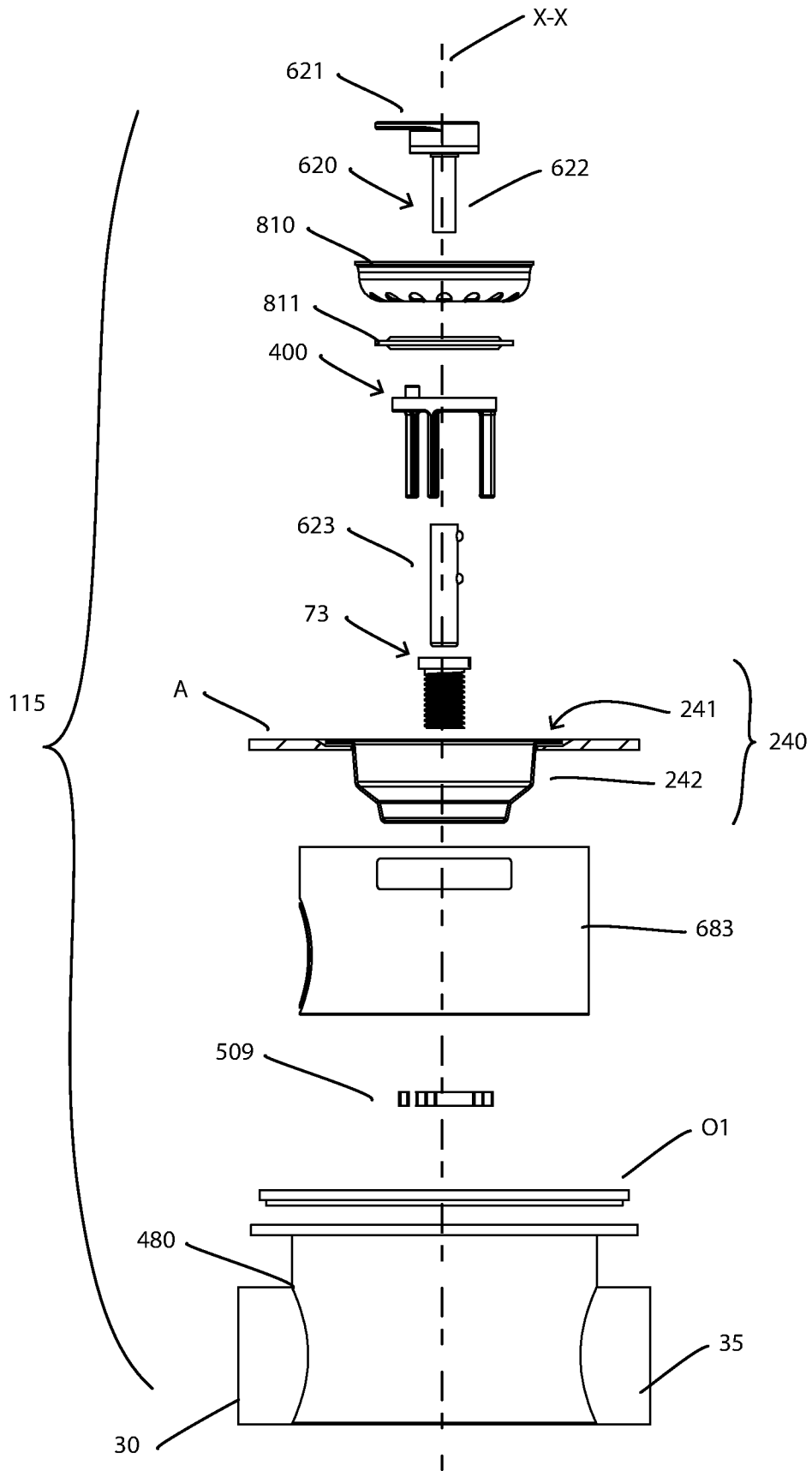

Fig. 27

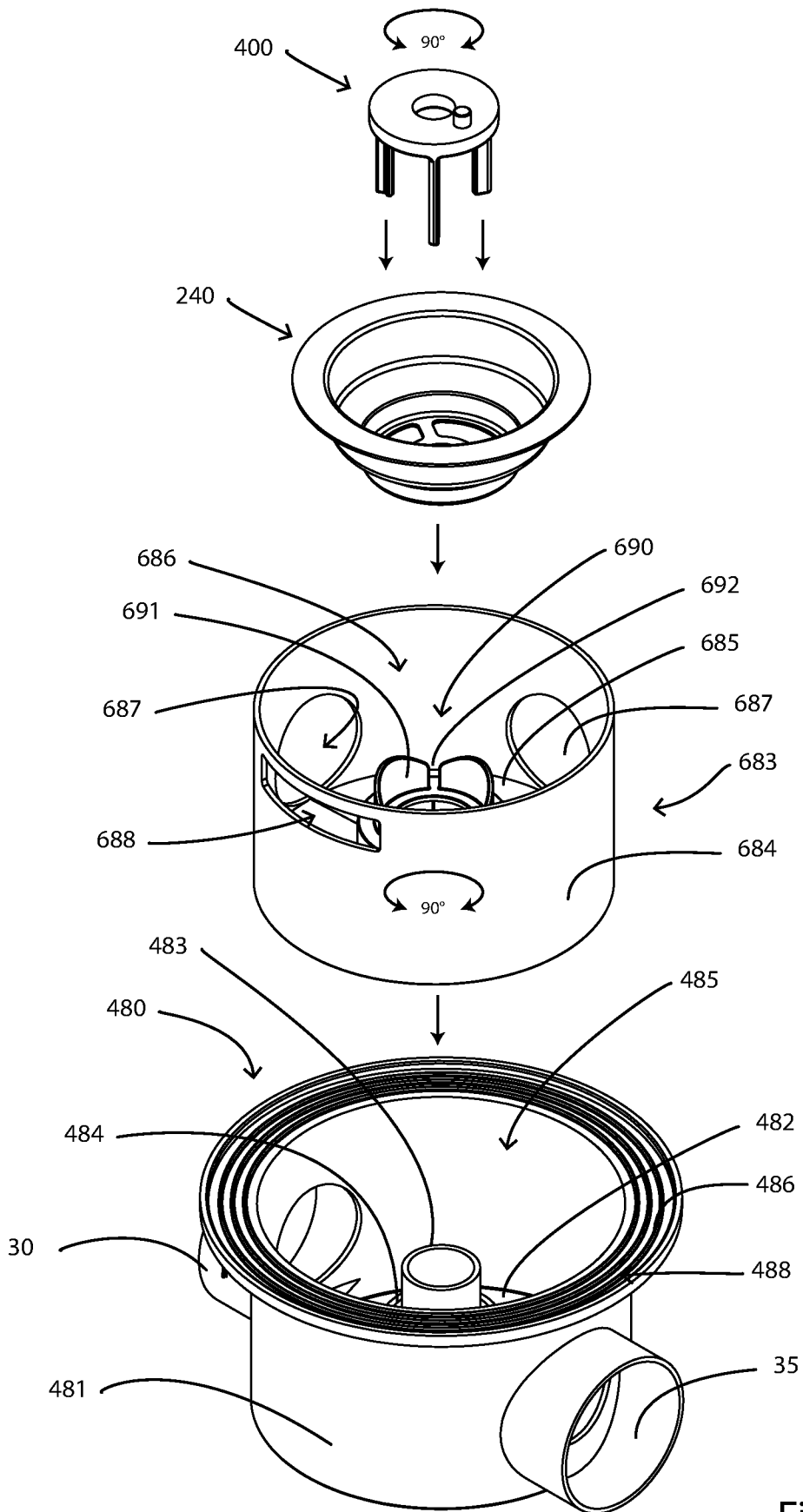

Fig. 28

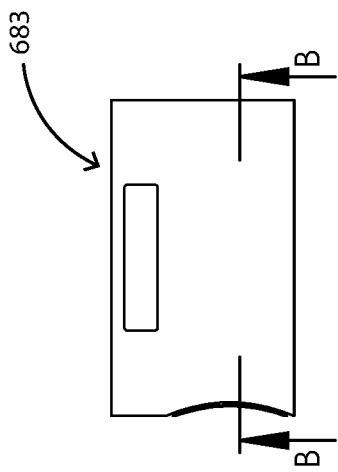

Fig. 29A

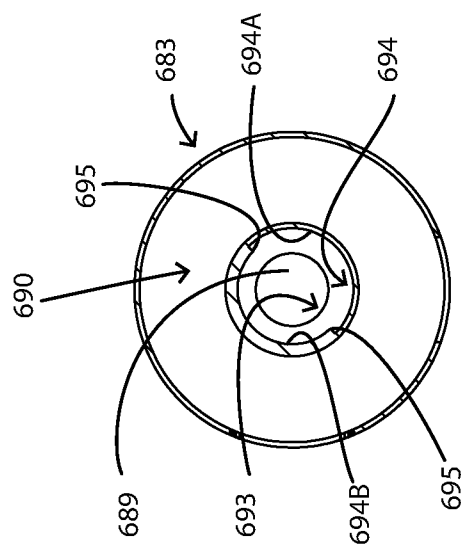

Fig. 29B

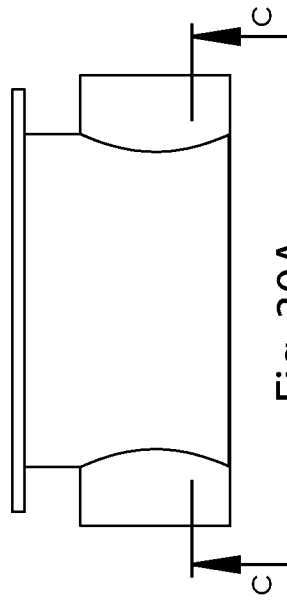

Fig. 30A

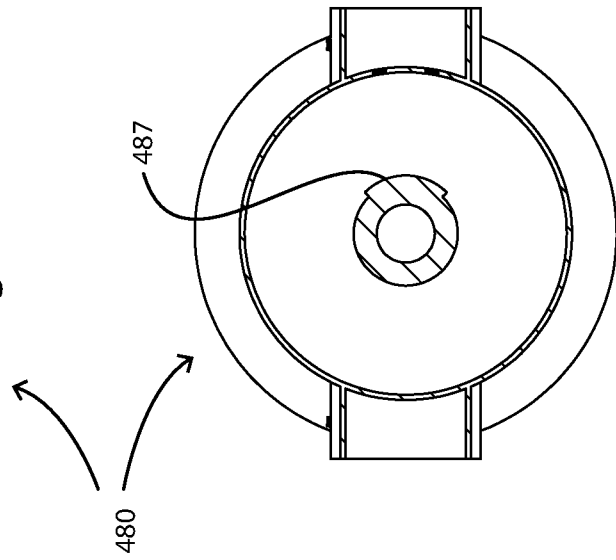
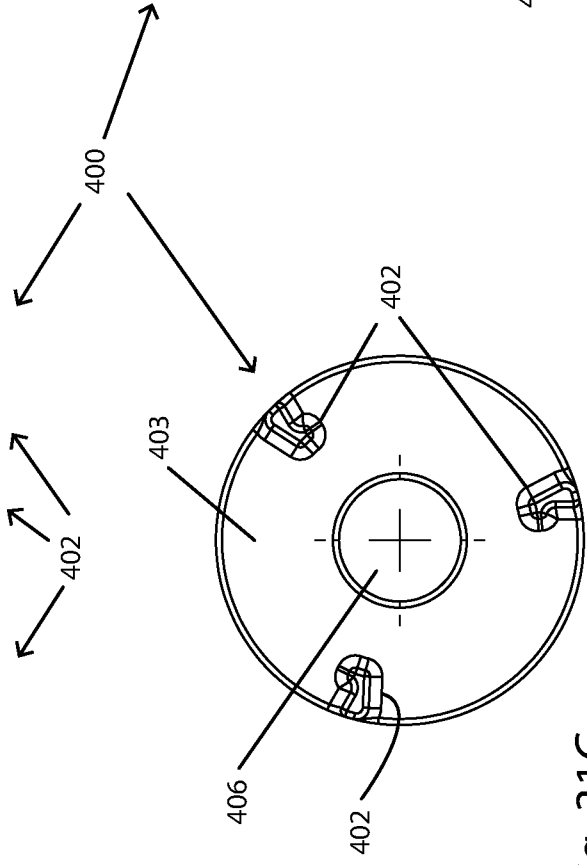
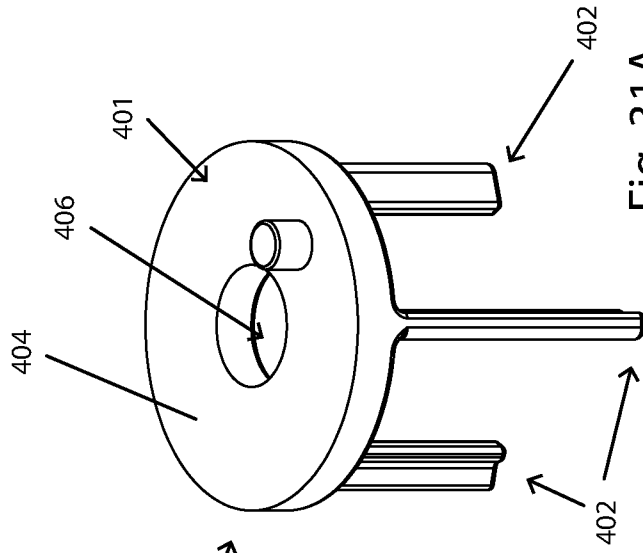
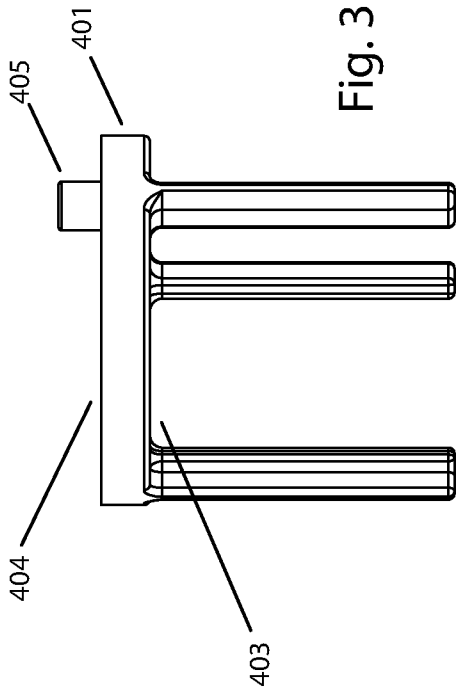

Fig. 30B





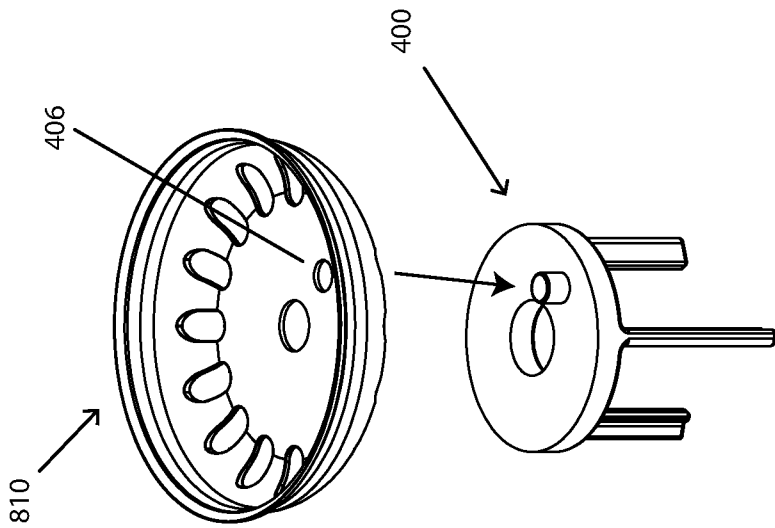
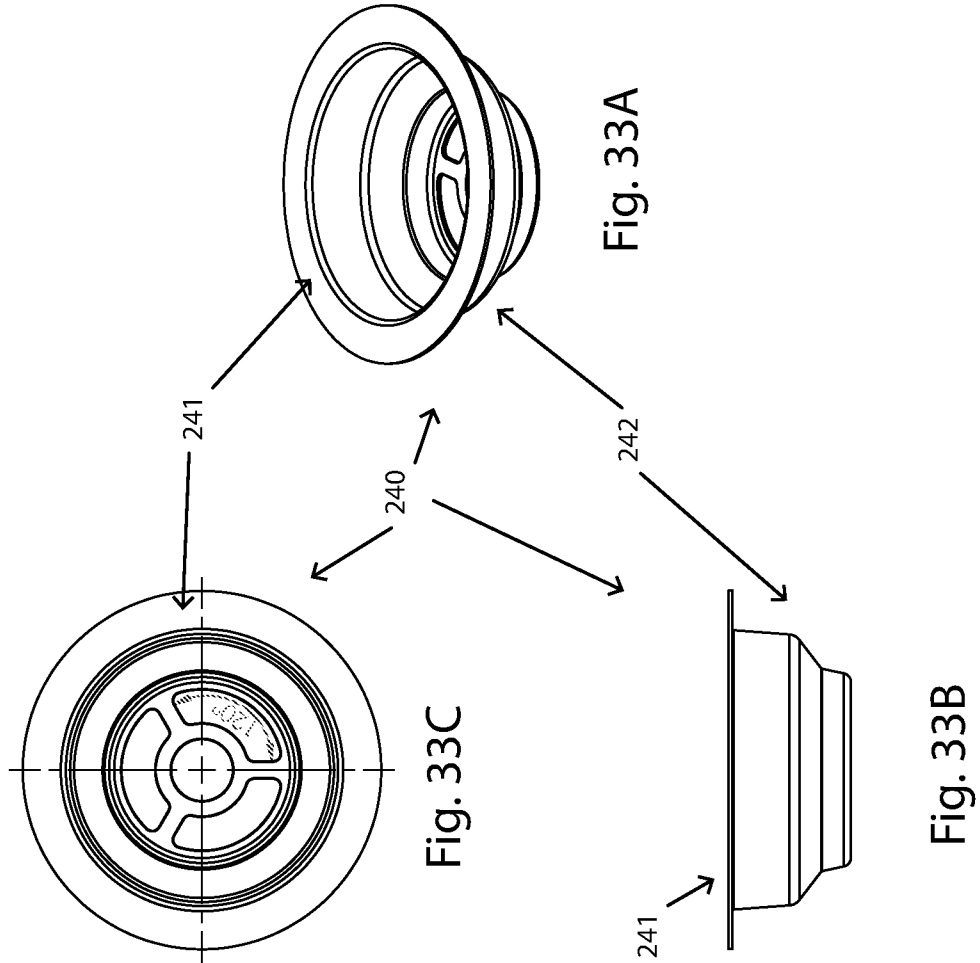

Fig. 32

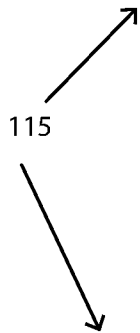
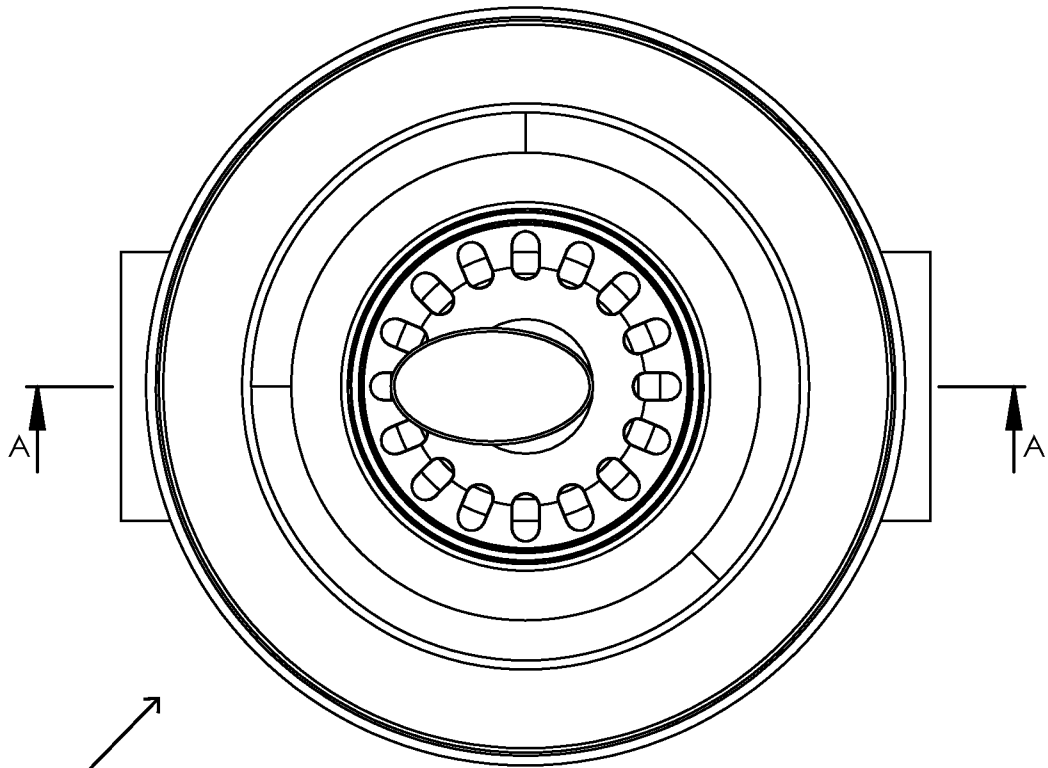
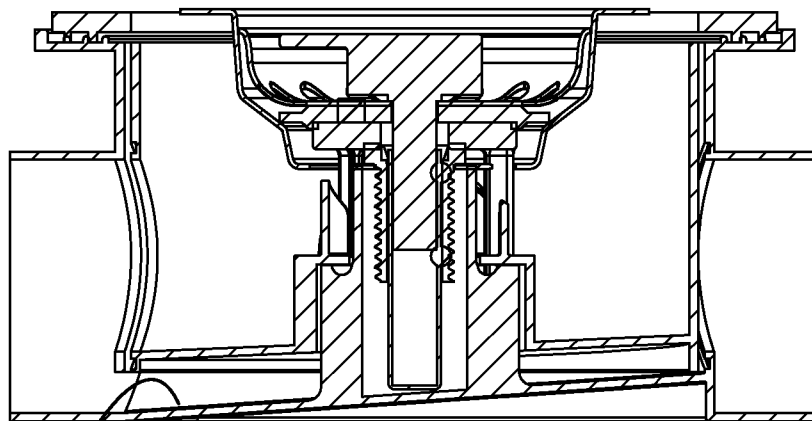

Fig. 34A



482

A line with an arrowhead points from the numeral 482 to a specific part of the assembly in Fig. 34B, likely a spring or a component of the central mechanism.

Fig. 34B

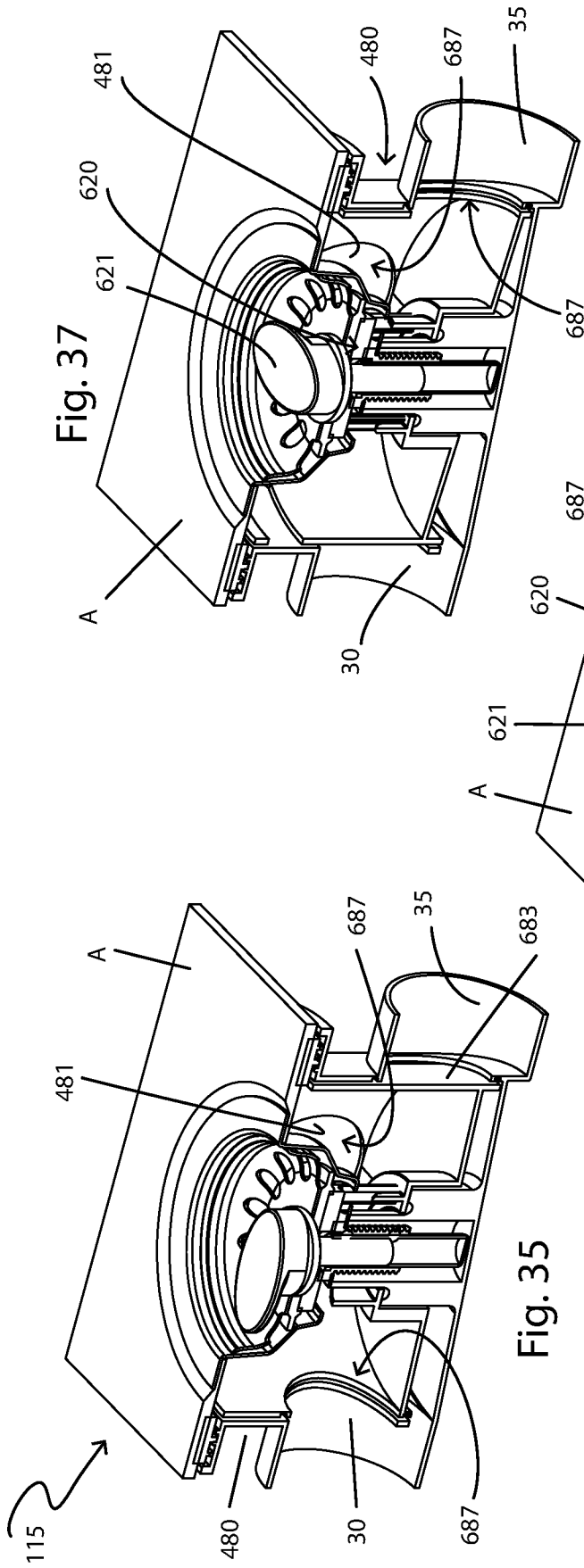

Fig. 35

Fig. 37

Fig. 36

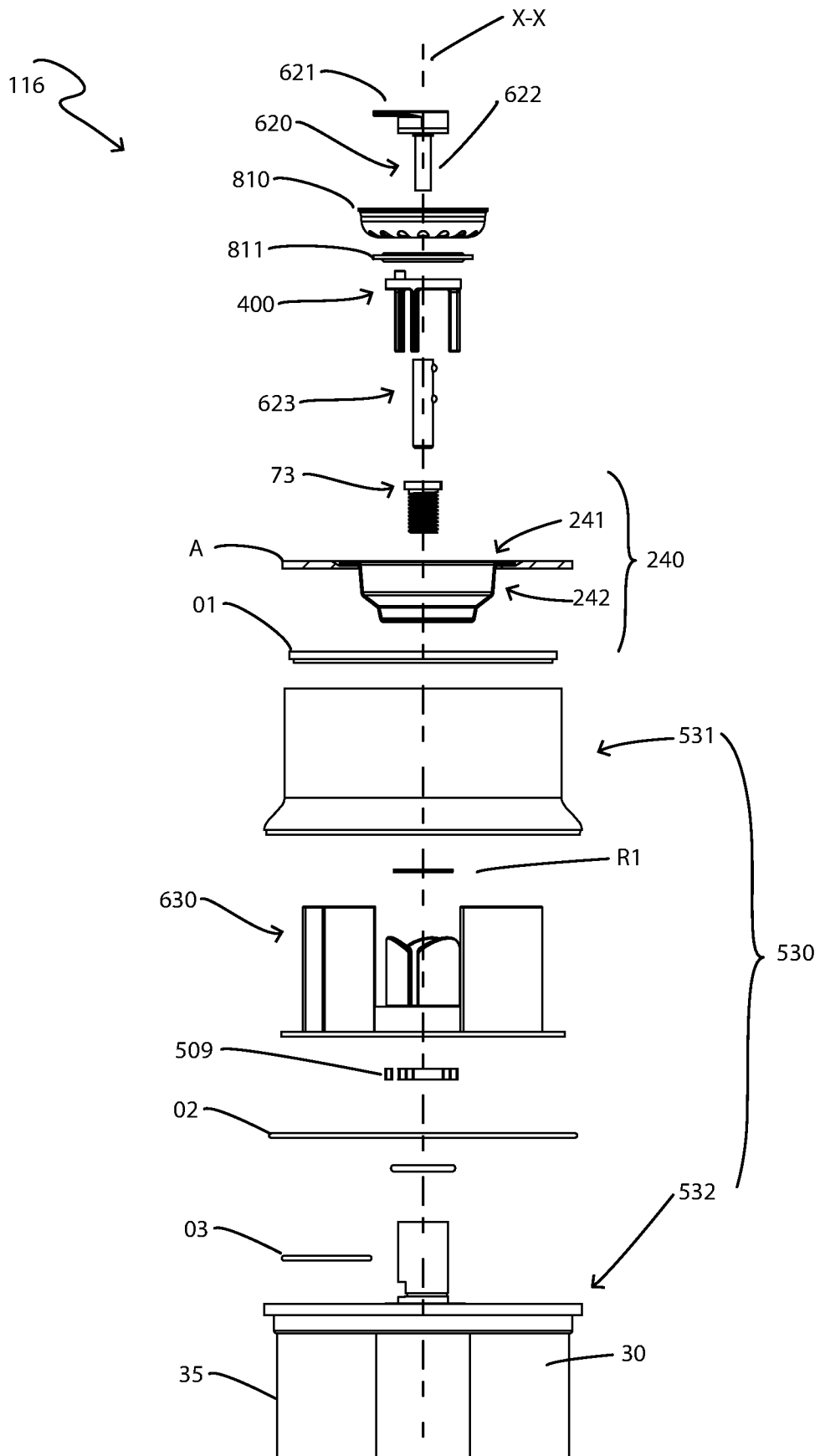

Fig. 38

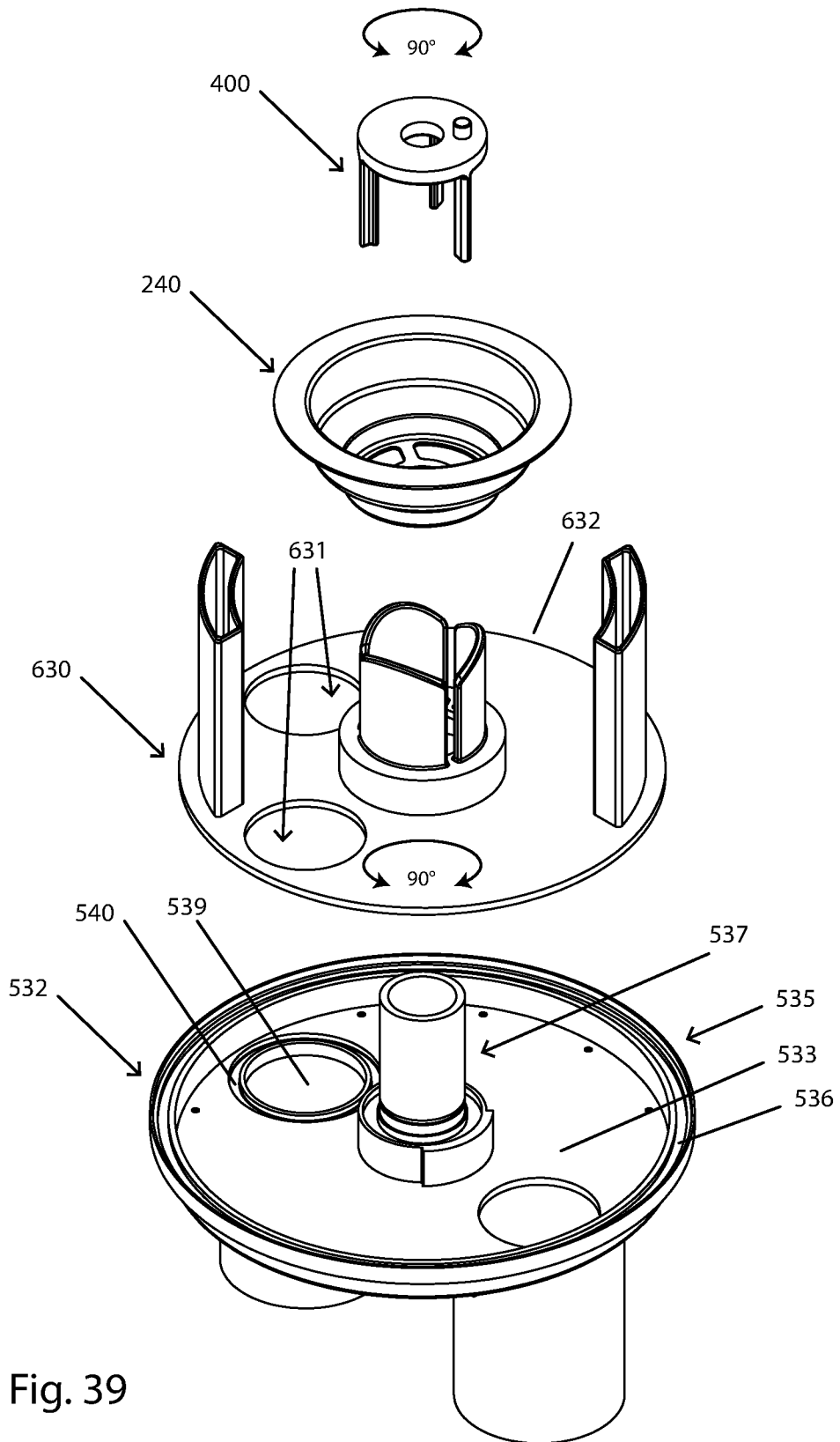
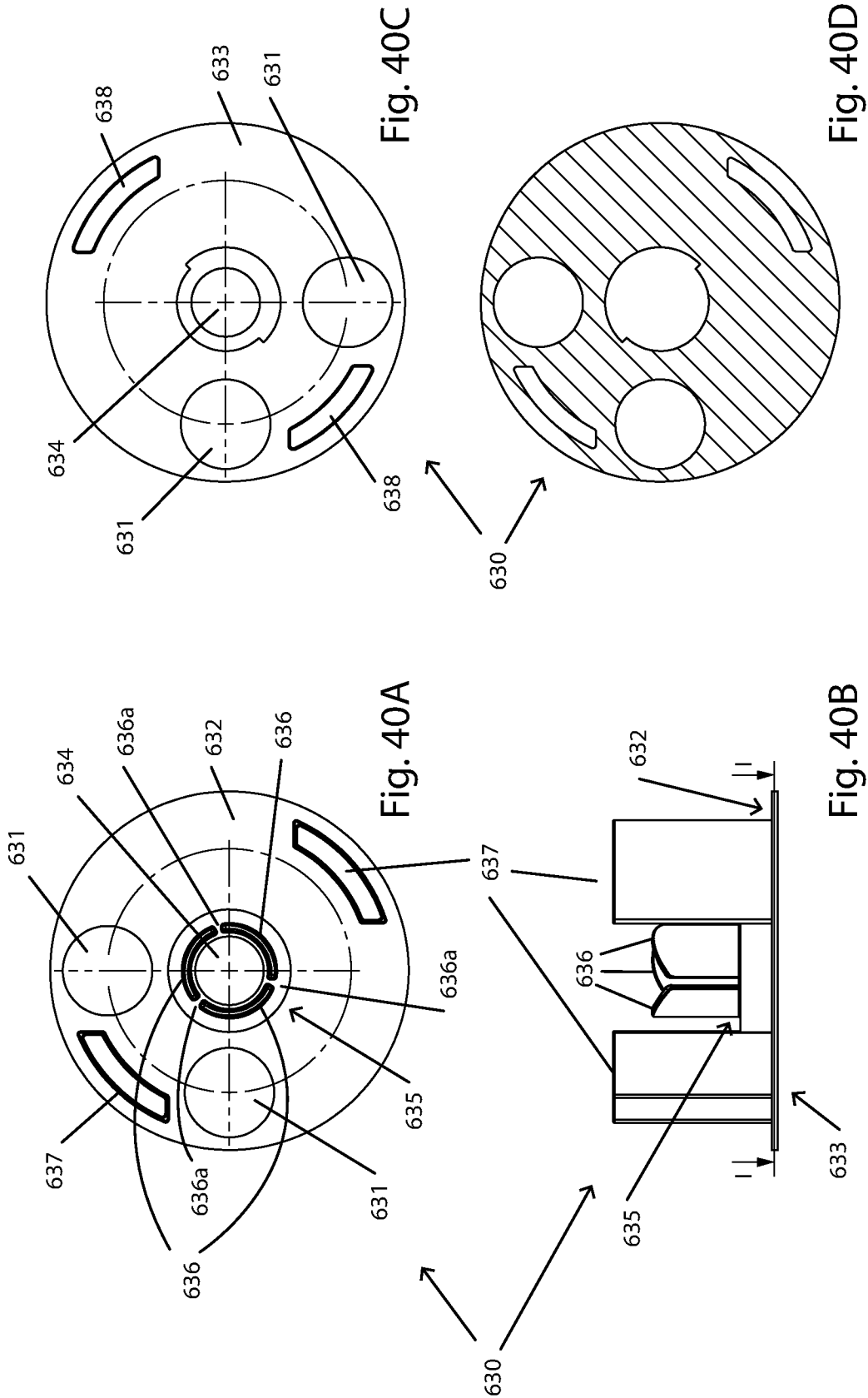

Fig. 39



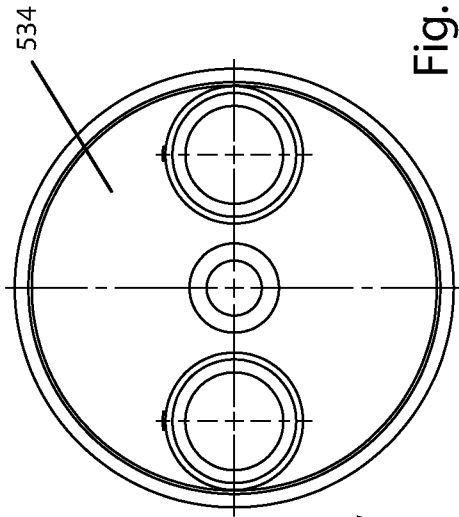

Fig. 41C

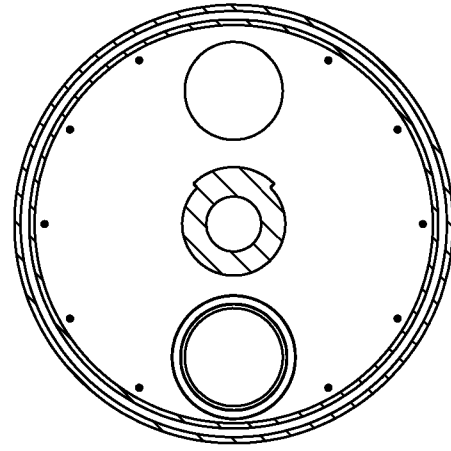

Fig. 41D

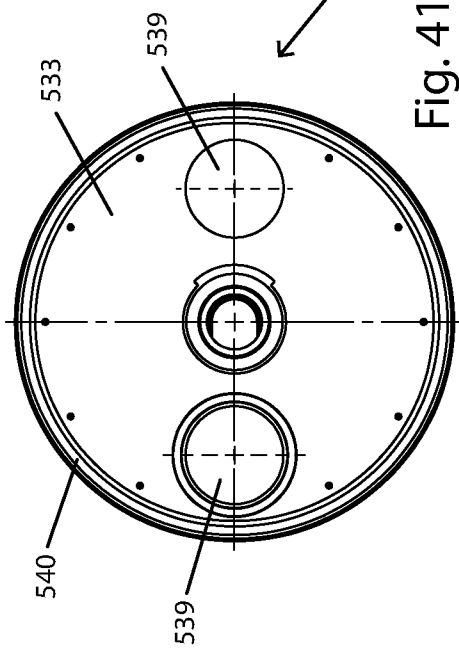

Fig. 41A

532

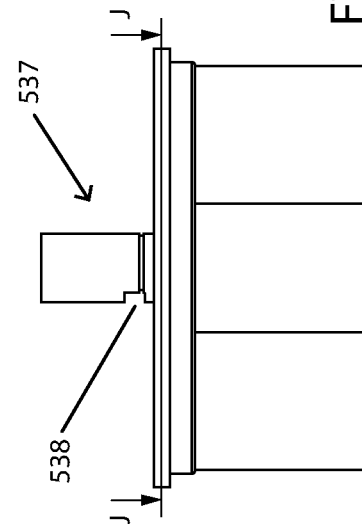

Fig. 41B



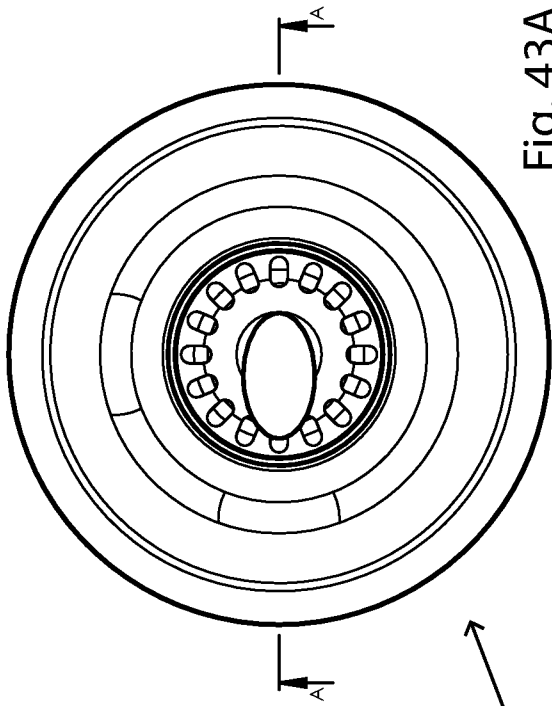

Fig. 43A

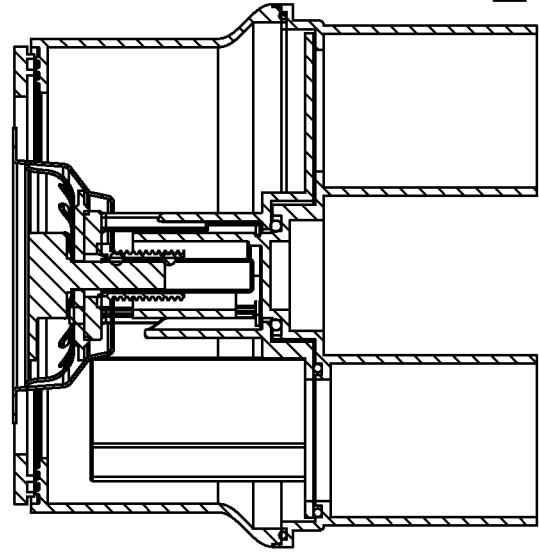

Fig. 43B

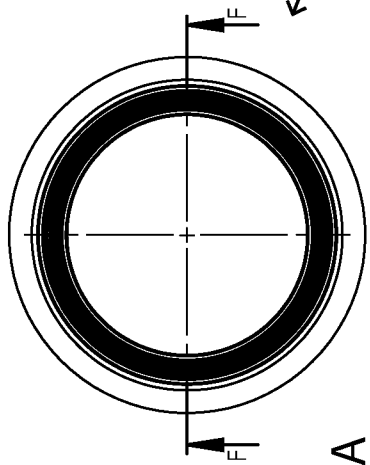

Fig. 42A

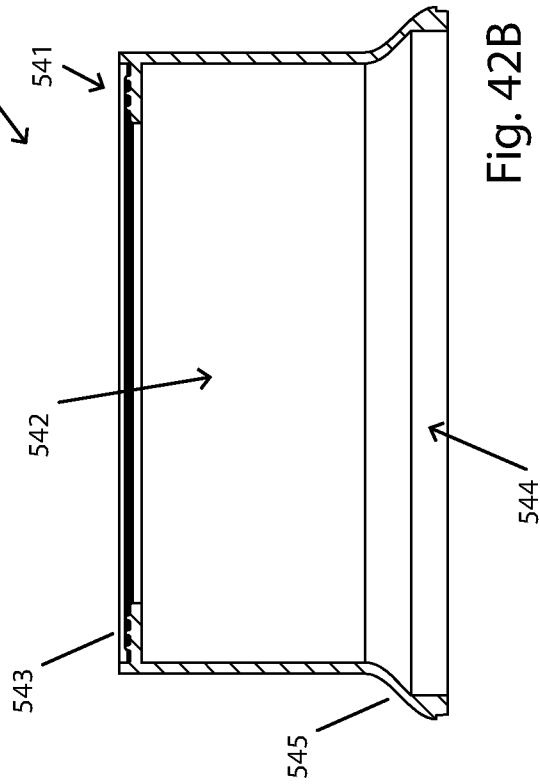

Fig. 42B

116

531

541

542

543

545

544

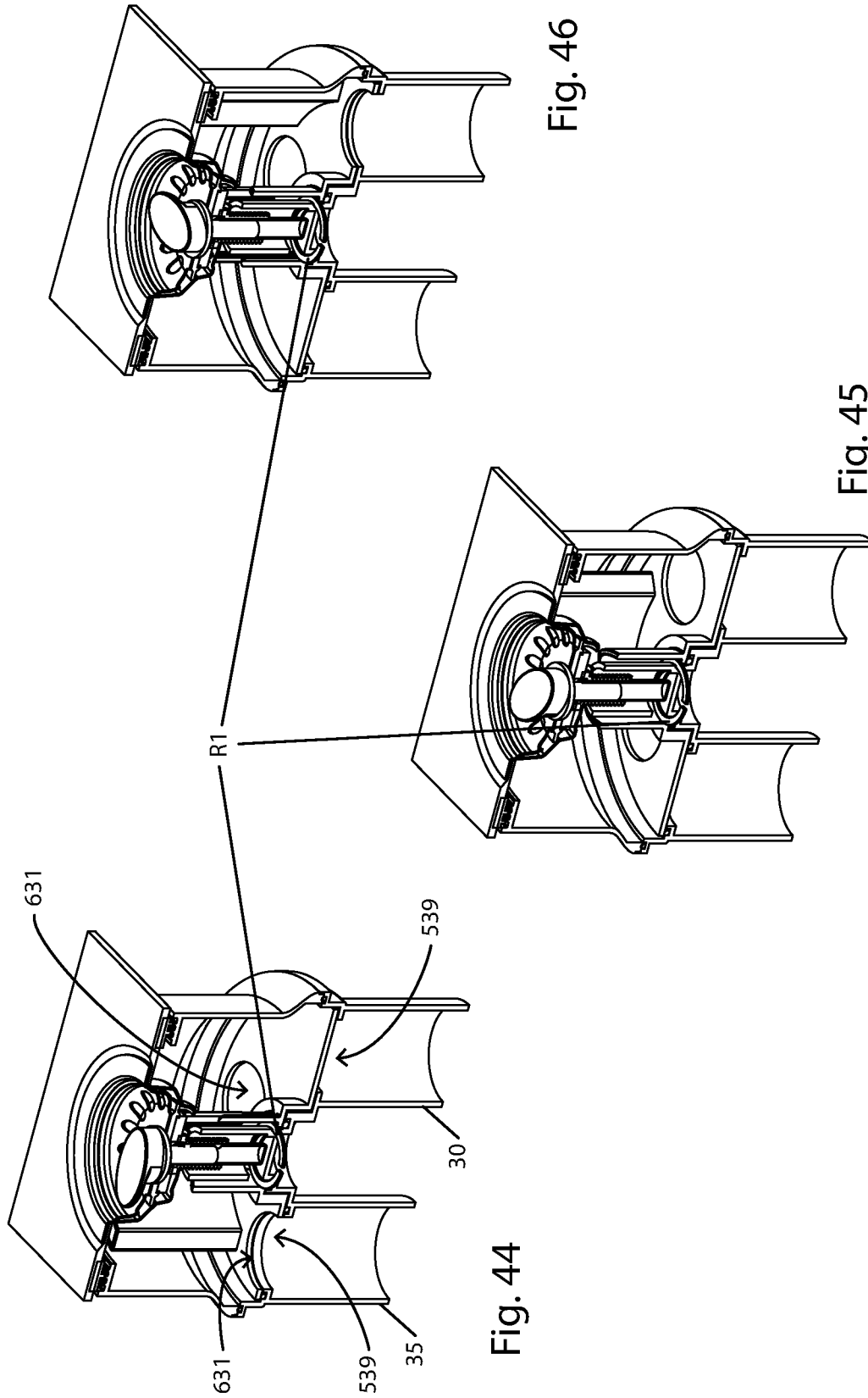

Fig. 44

Fig. 46

Fig. 45

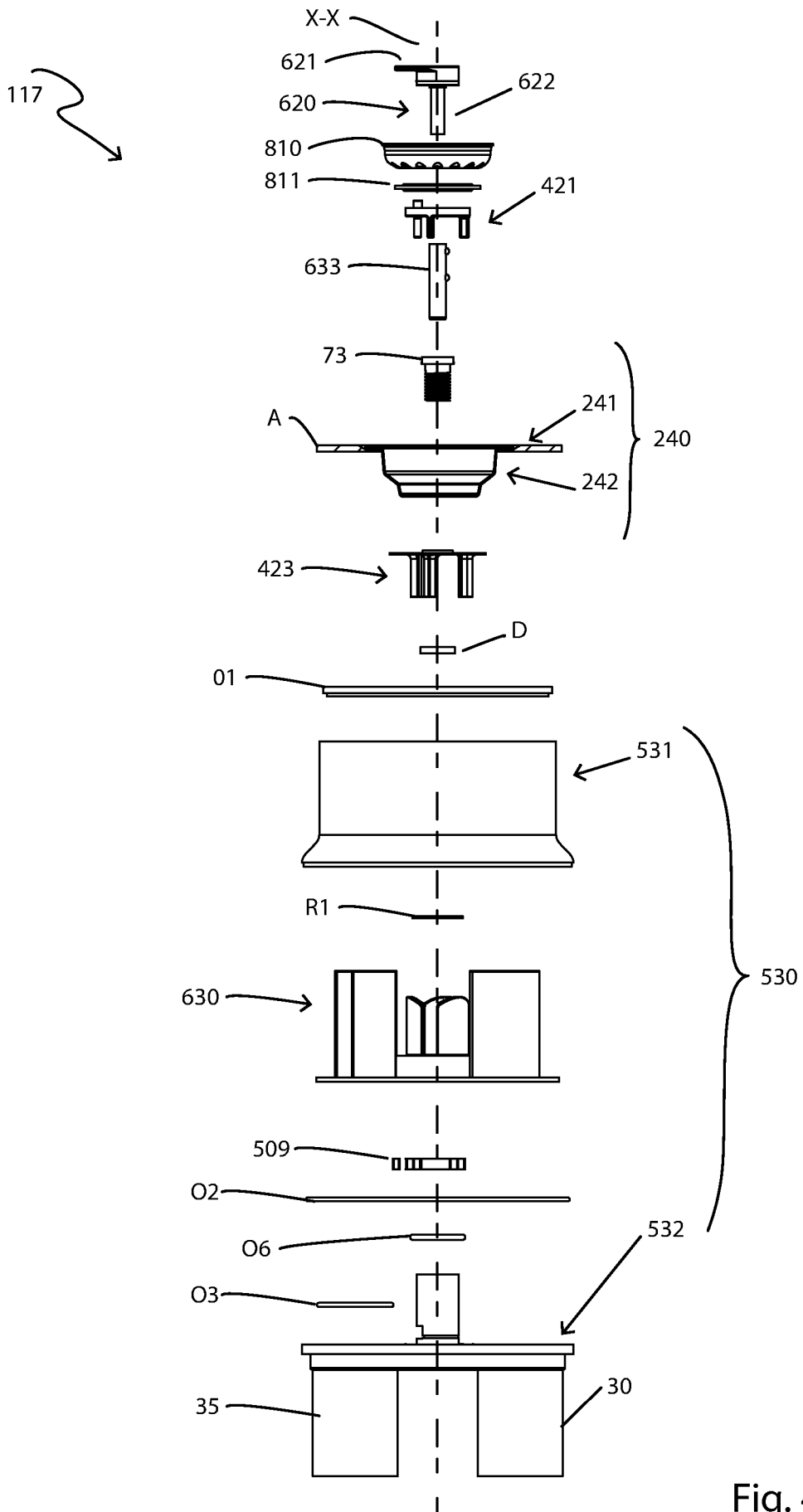

Fig. 47

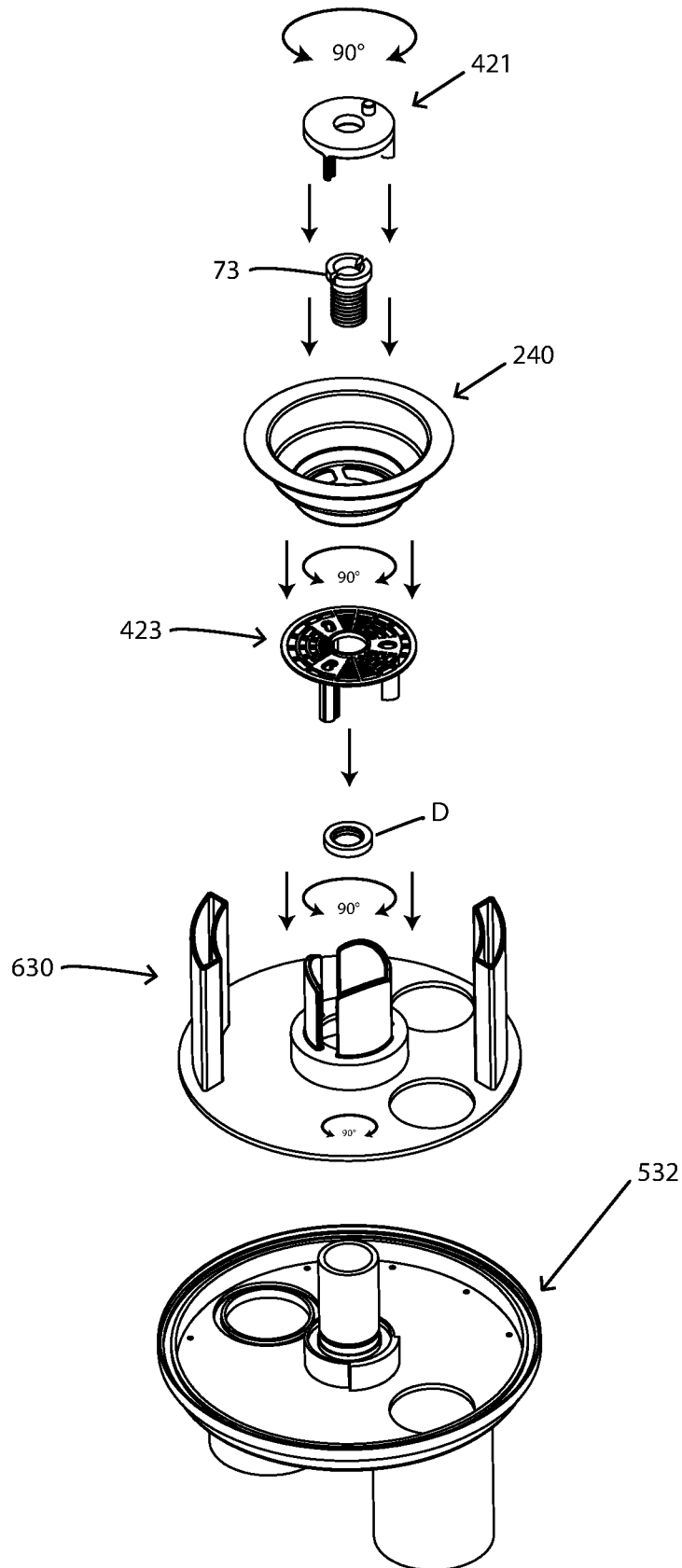

Fig. 48

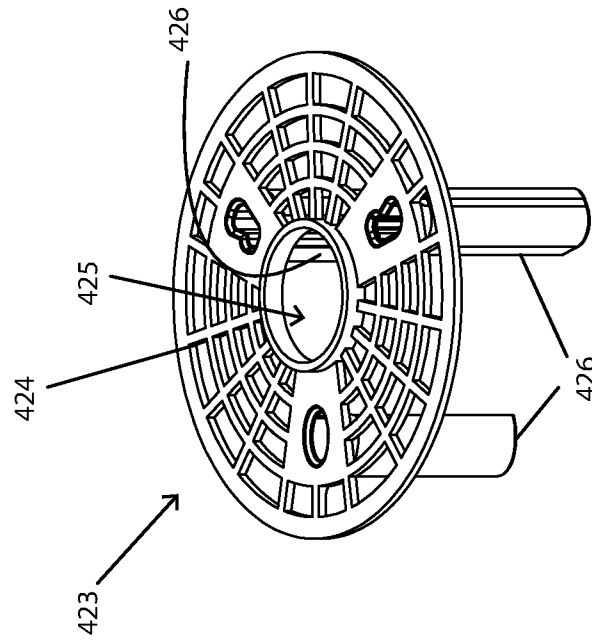

Fig. 50

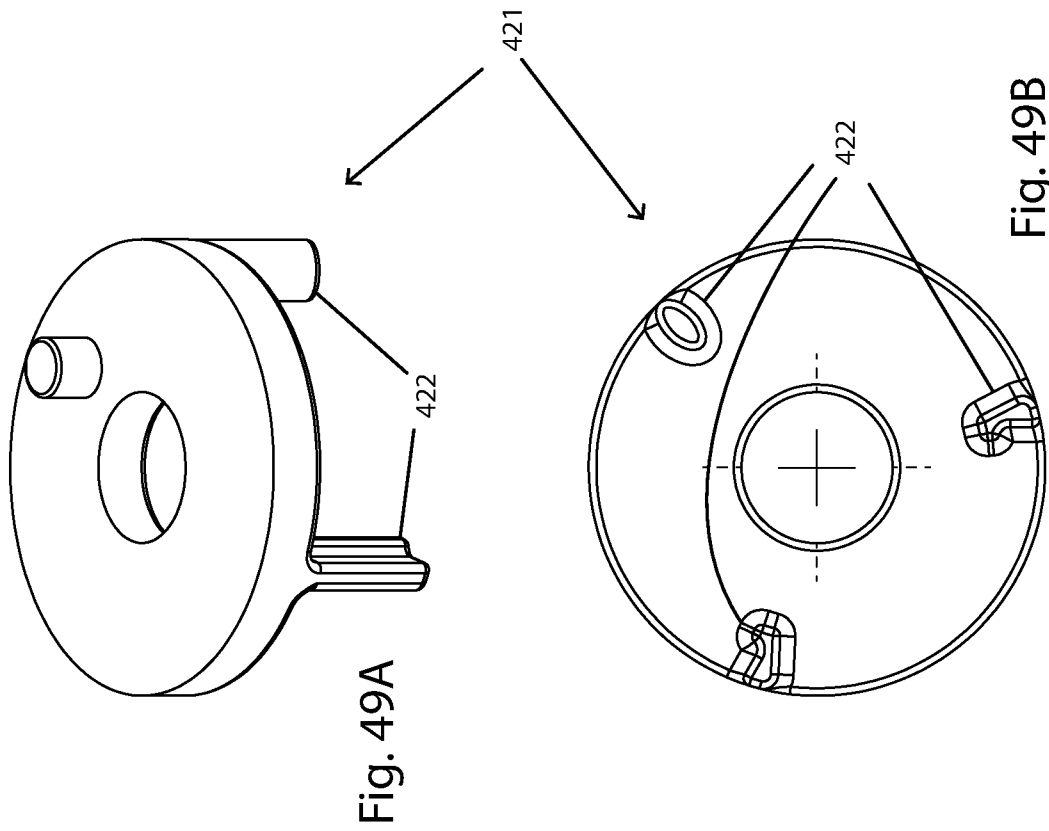

Fig. 49A

Fig. 49B

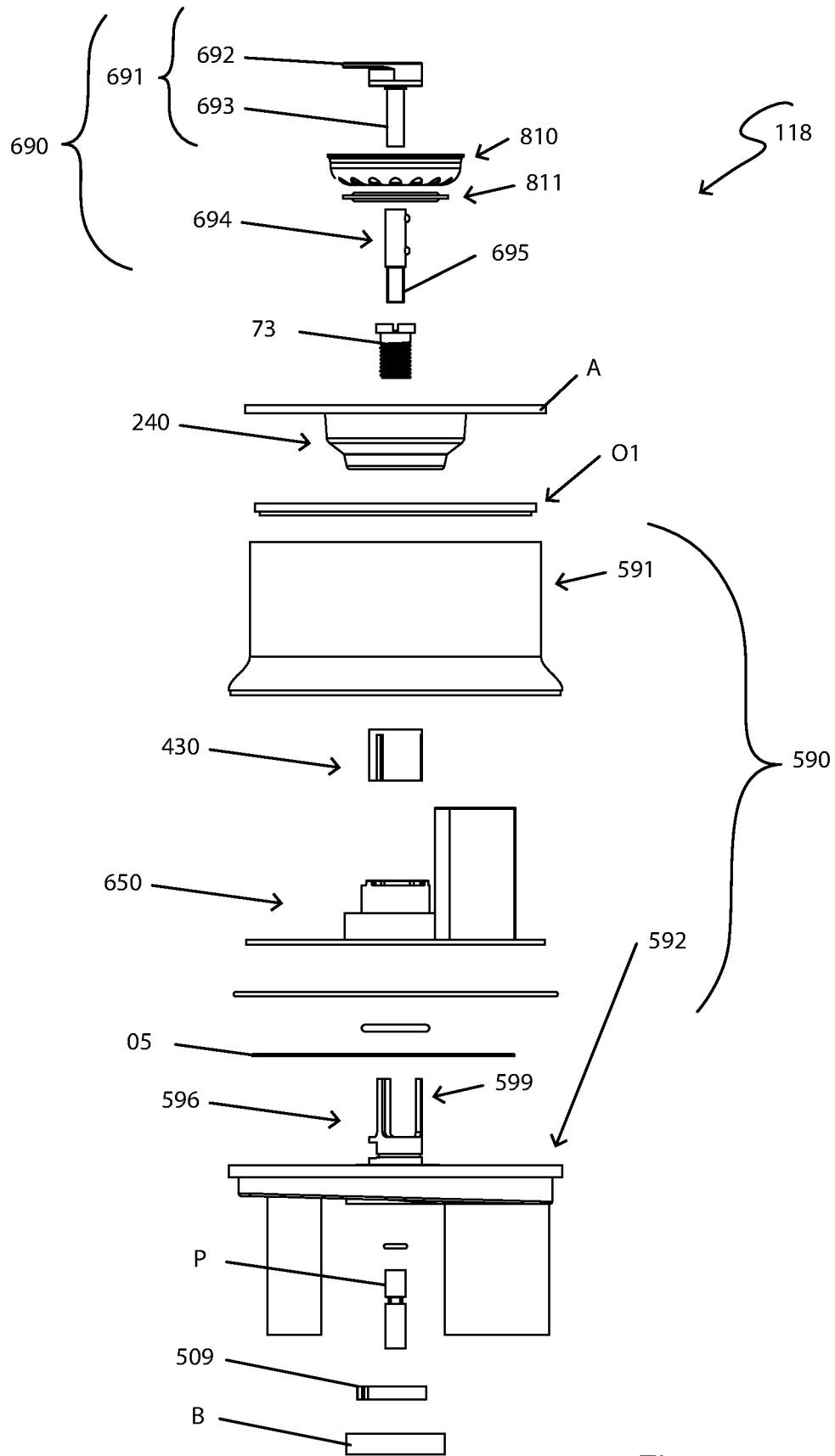

Fig. 51

Fig. 52A

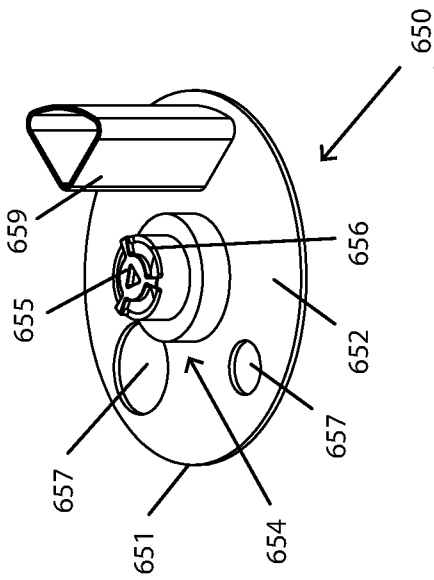

Fig. 52B

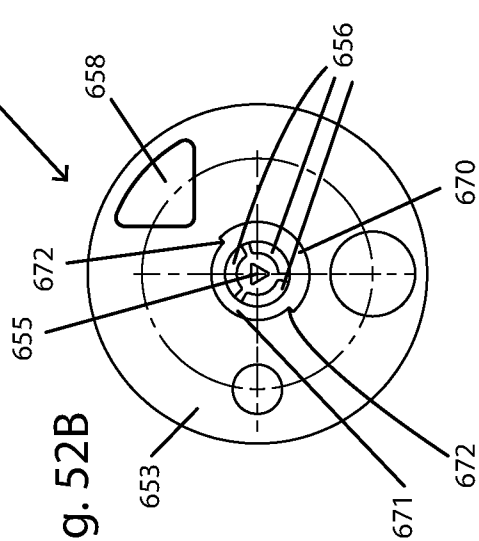

Fig. 53A

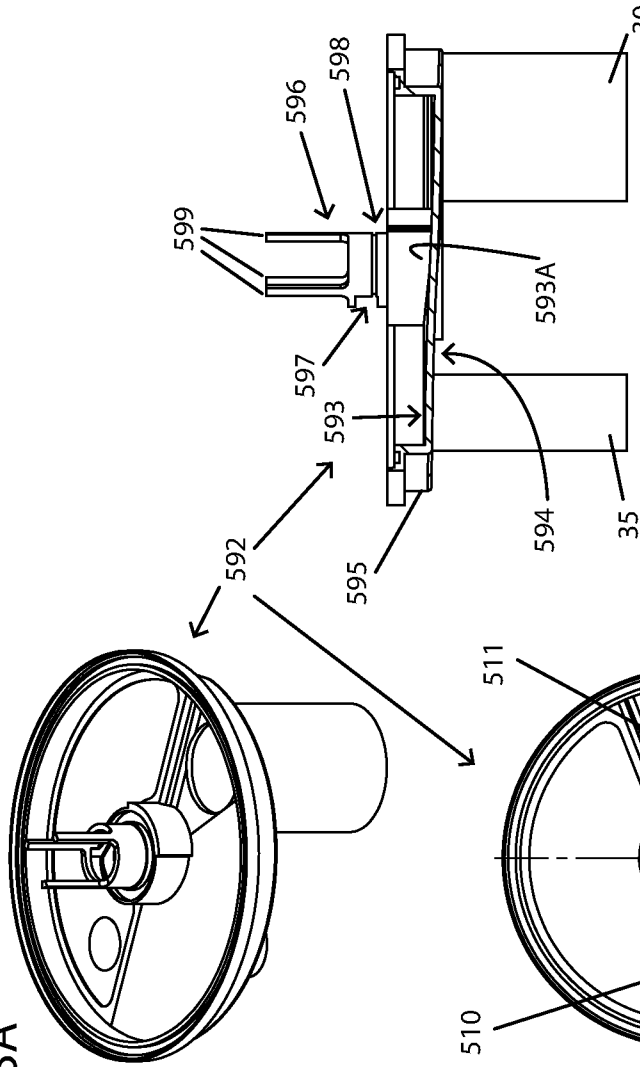

Fig. 53C

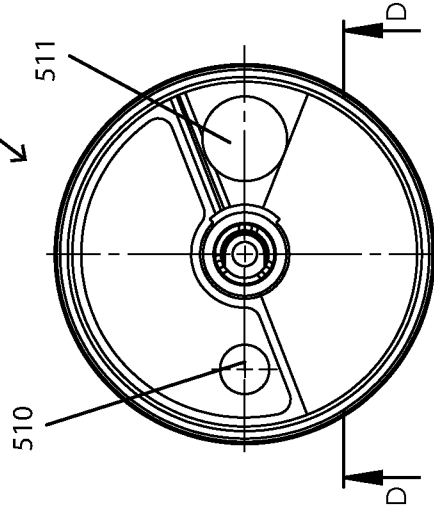

Fig. 53B

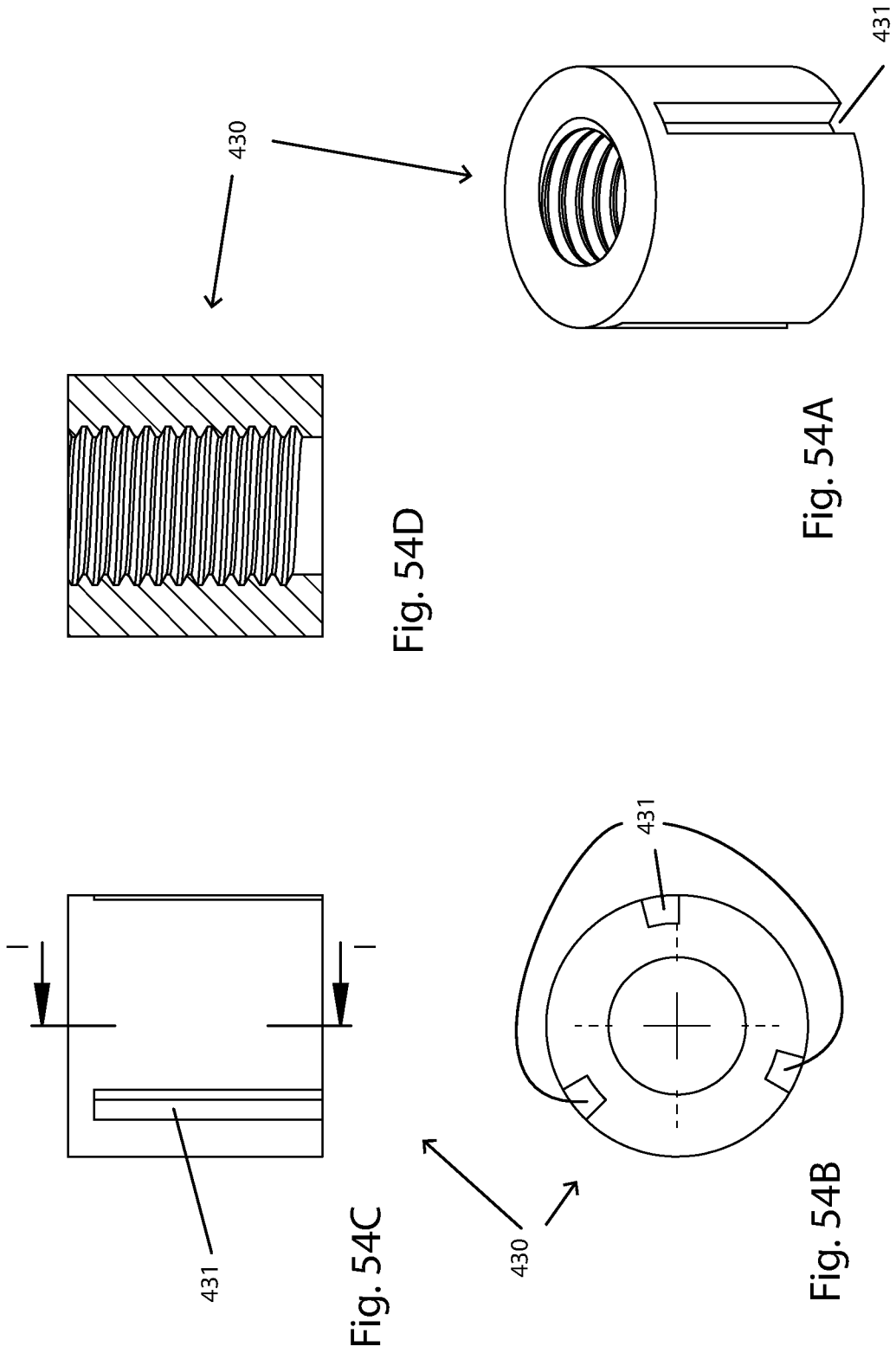

Fig. 54D

Fig. 54A

Fig. 54C

Fig. 54B



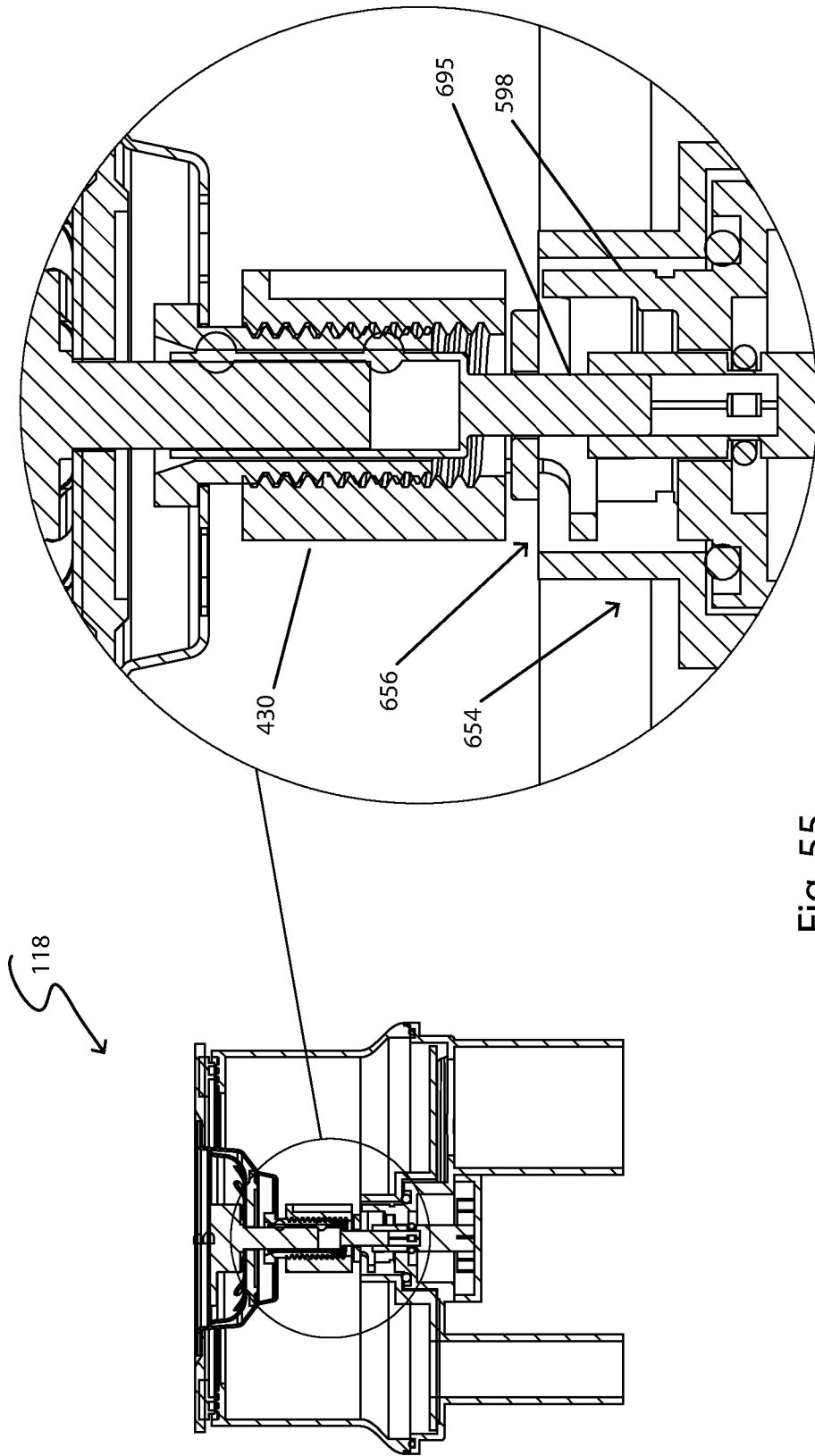

Fig. 55

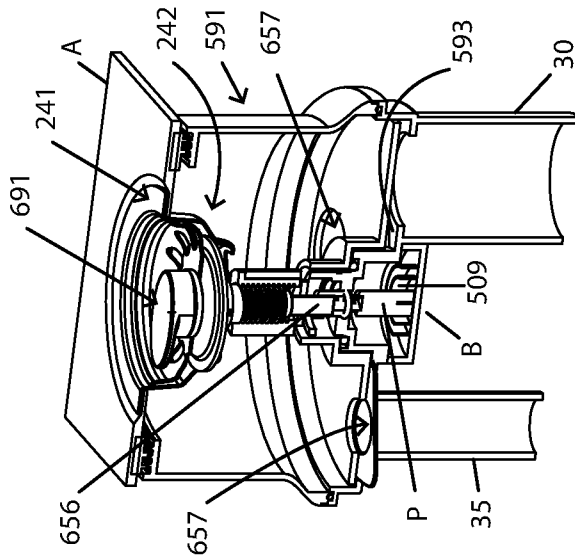
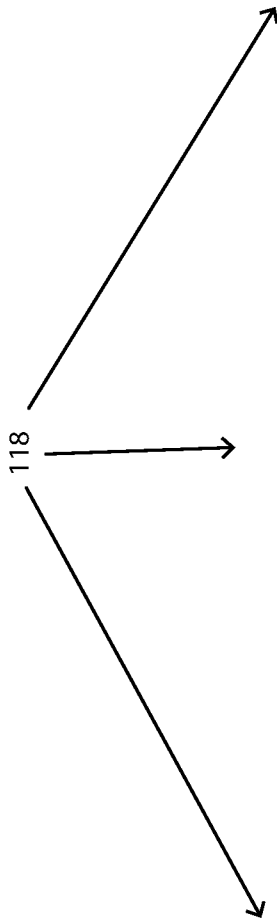

Fig. 56A

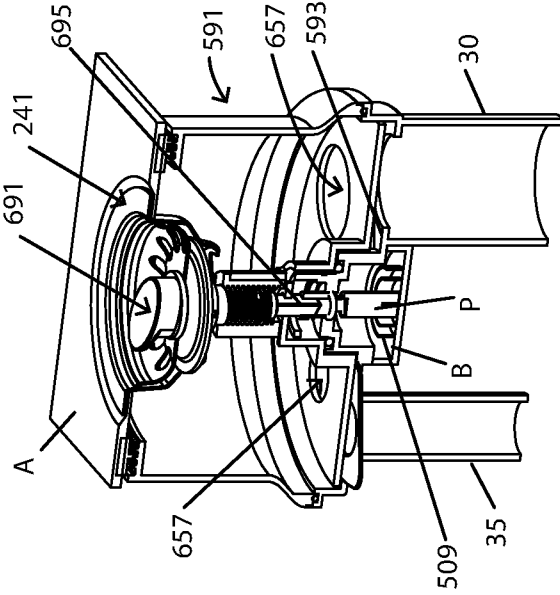

Fig. 56B

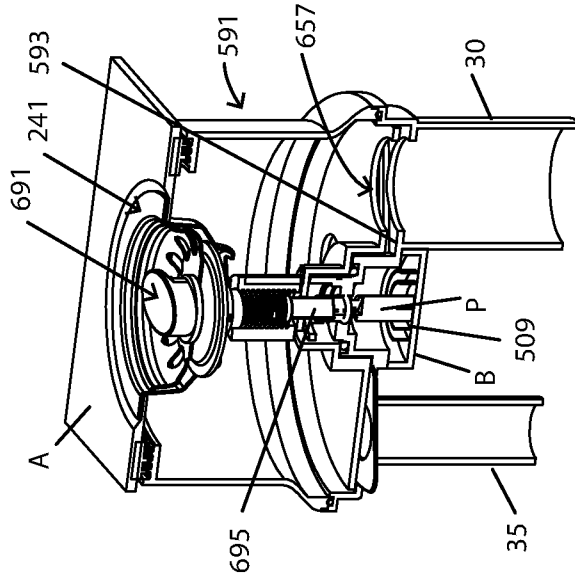

Fig. 56C

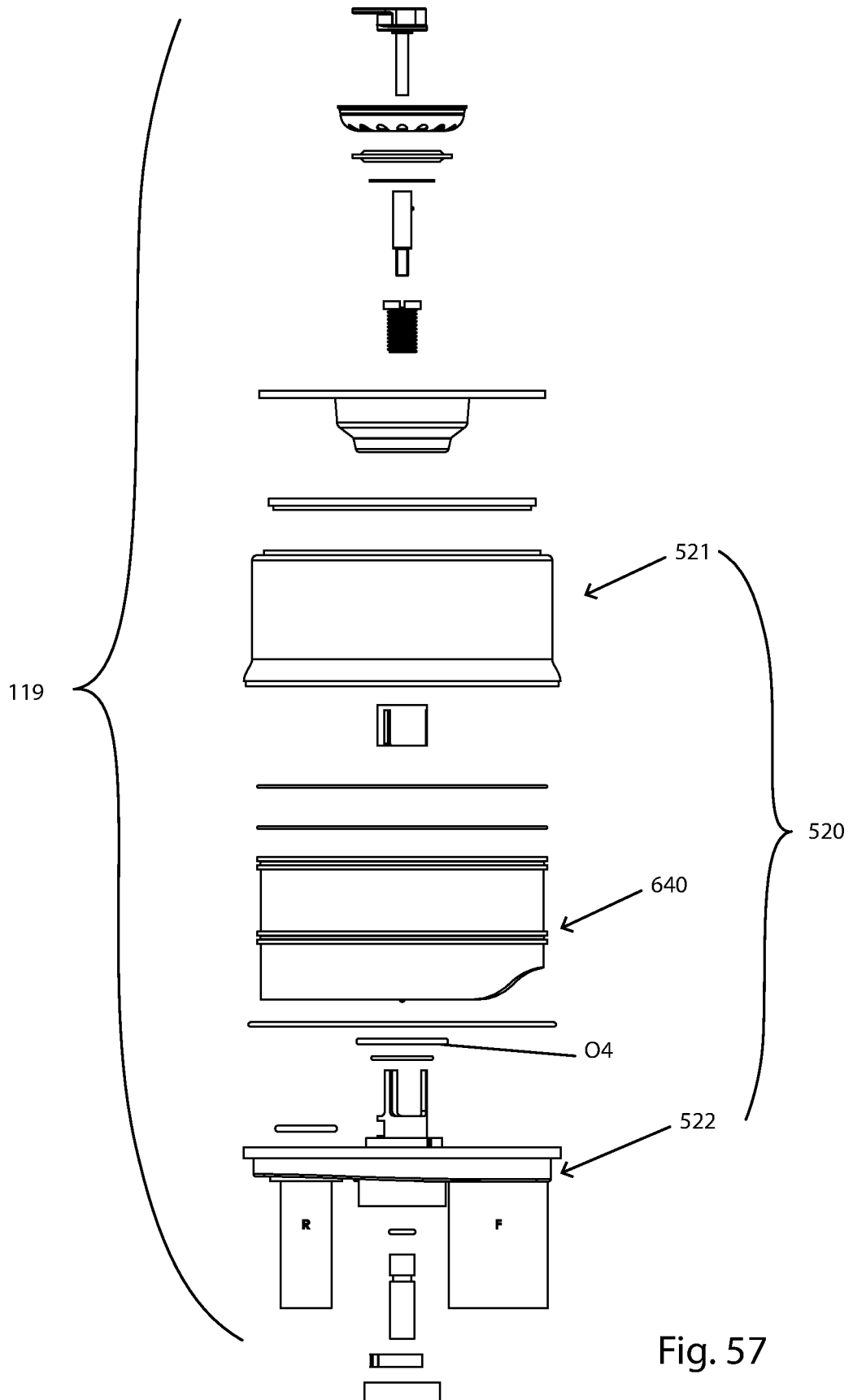

Fig. 57

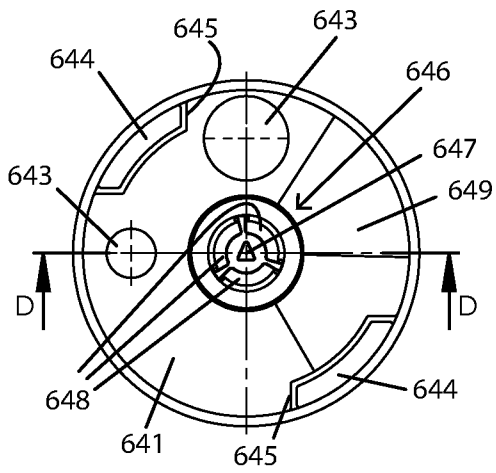

Fig. 58A

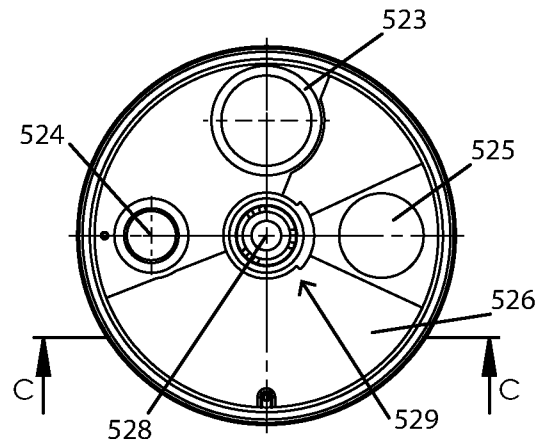

Fig. 59A

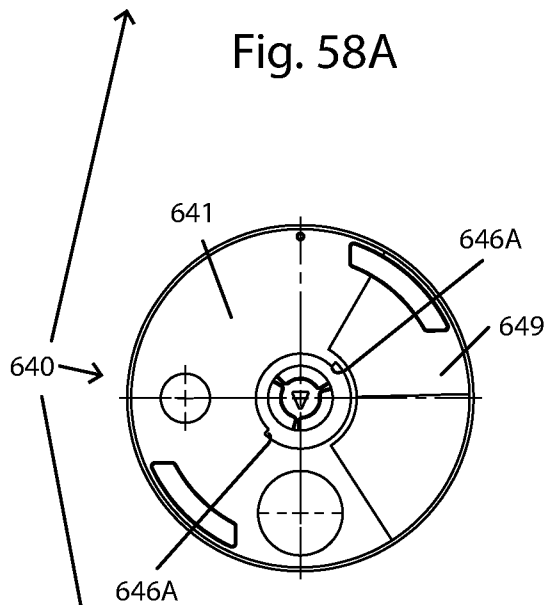

Fig. 58B

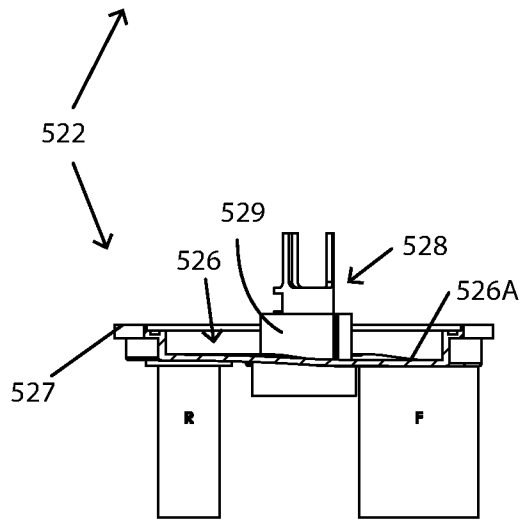

Fig. 59B

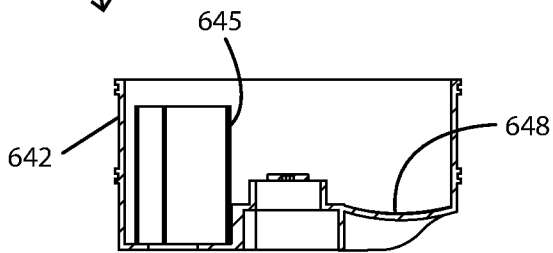
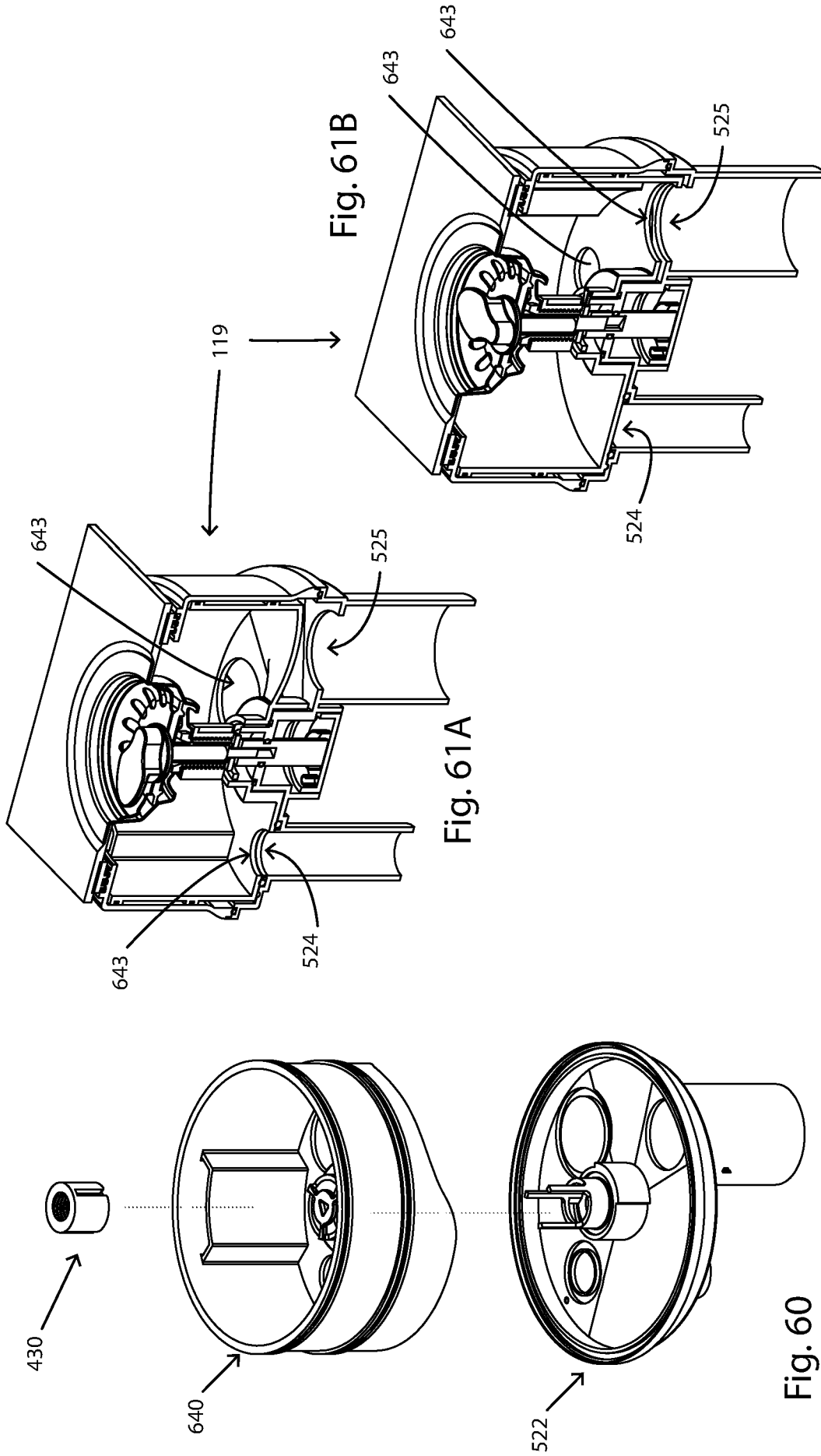

Fig. 58C



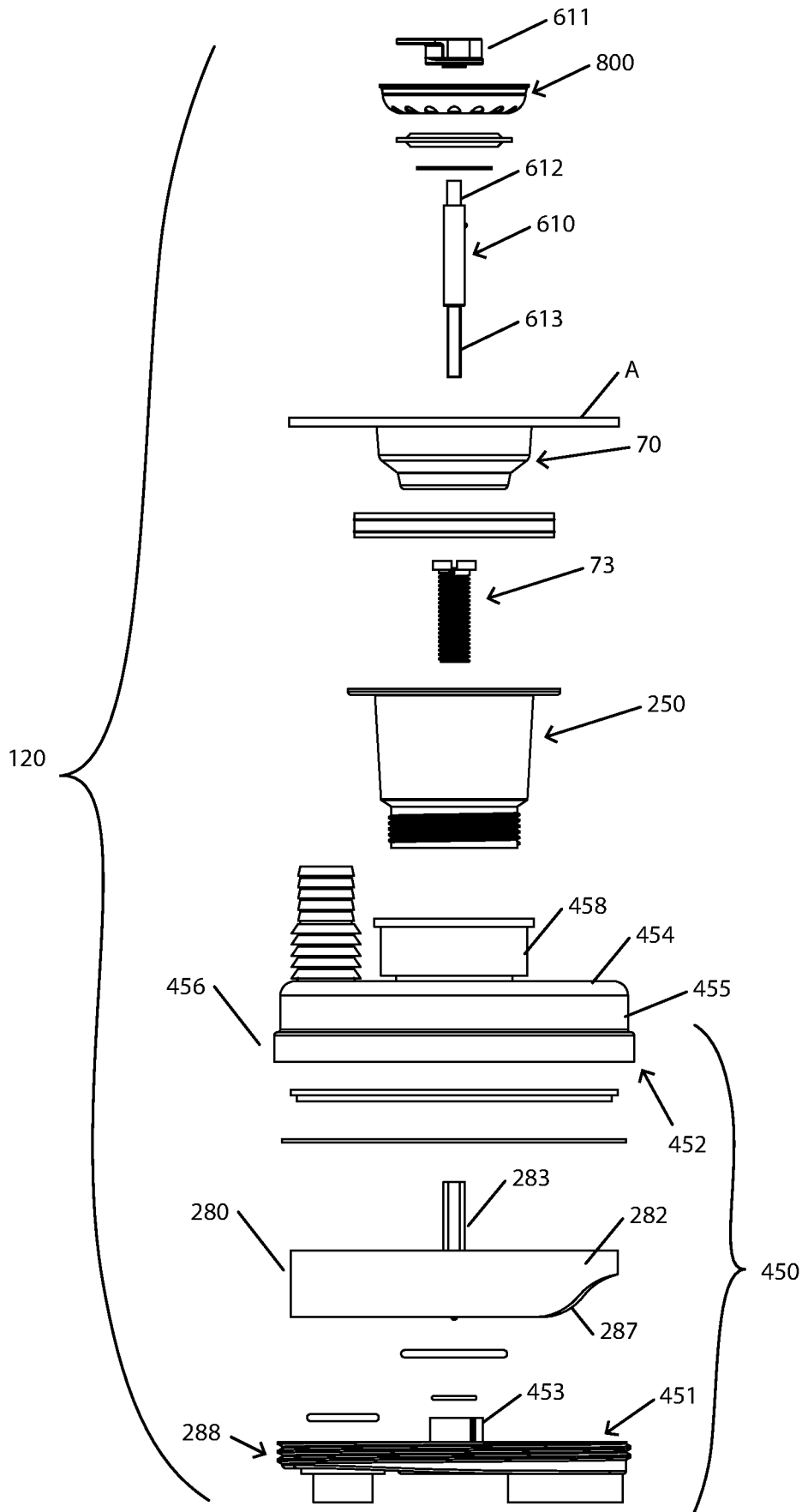

Fig. 62

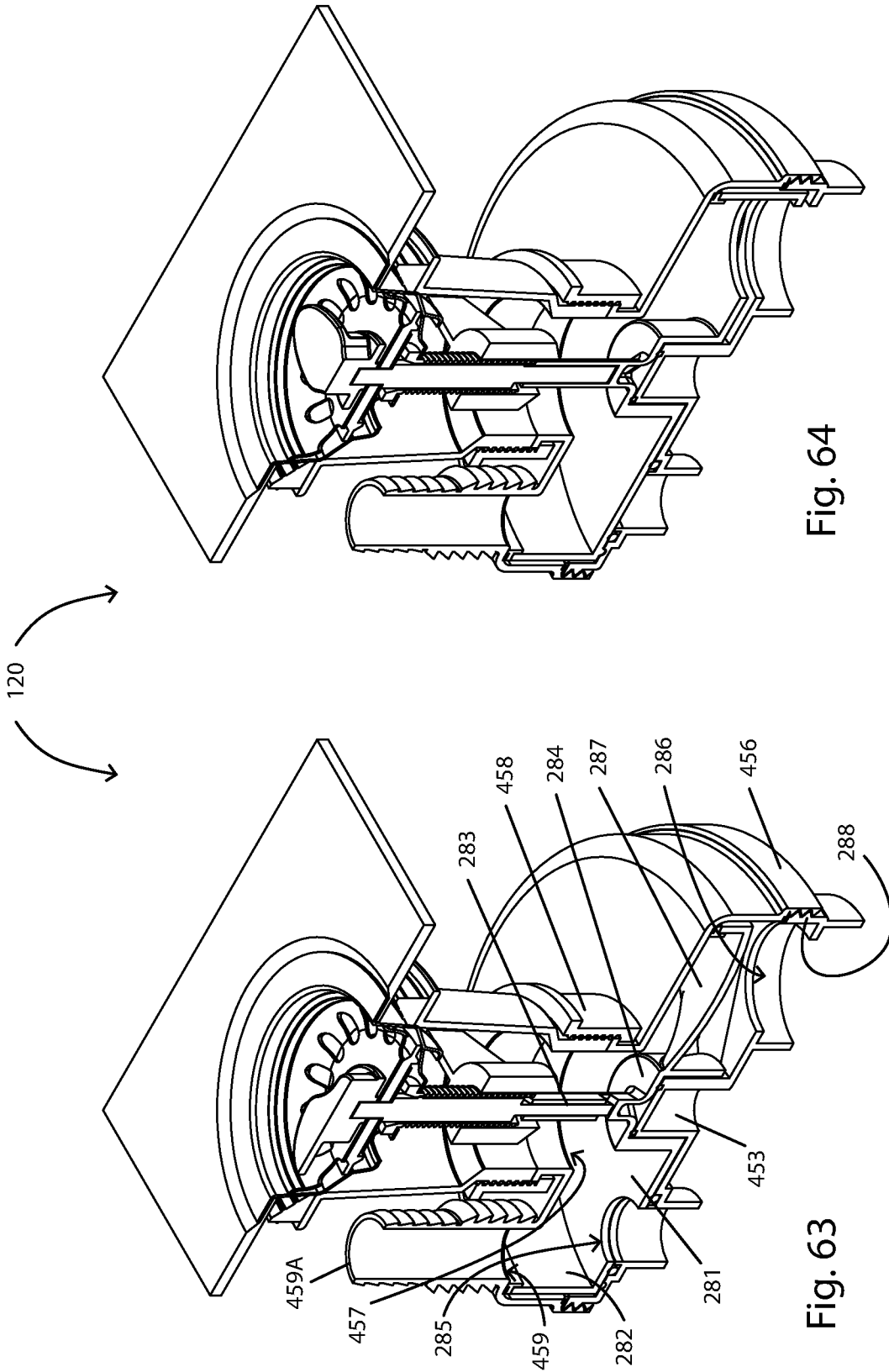

Fig. 64

Fig. 63

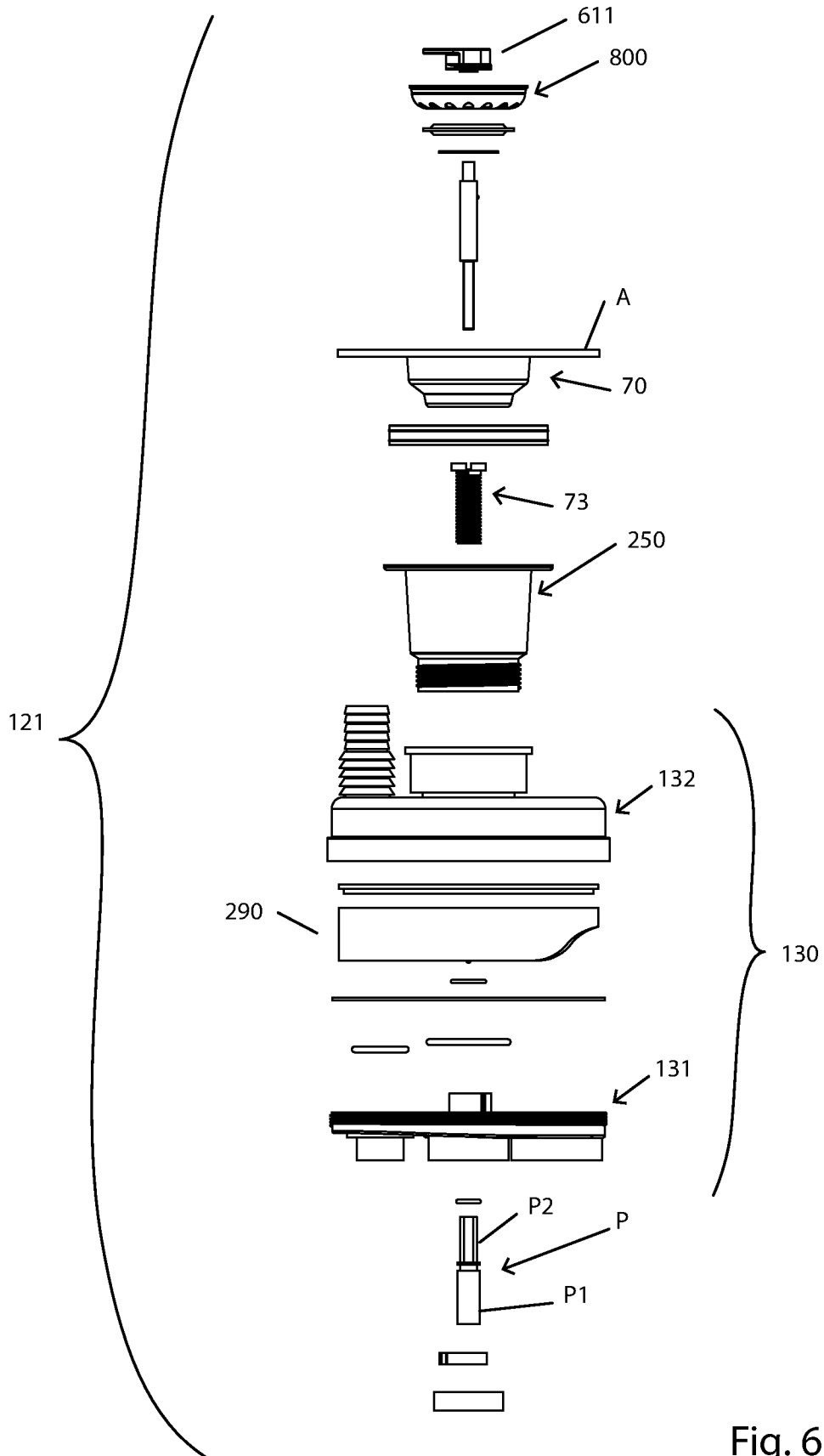

Fig. 65



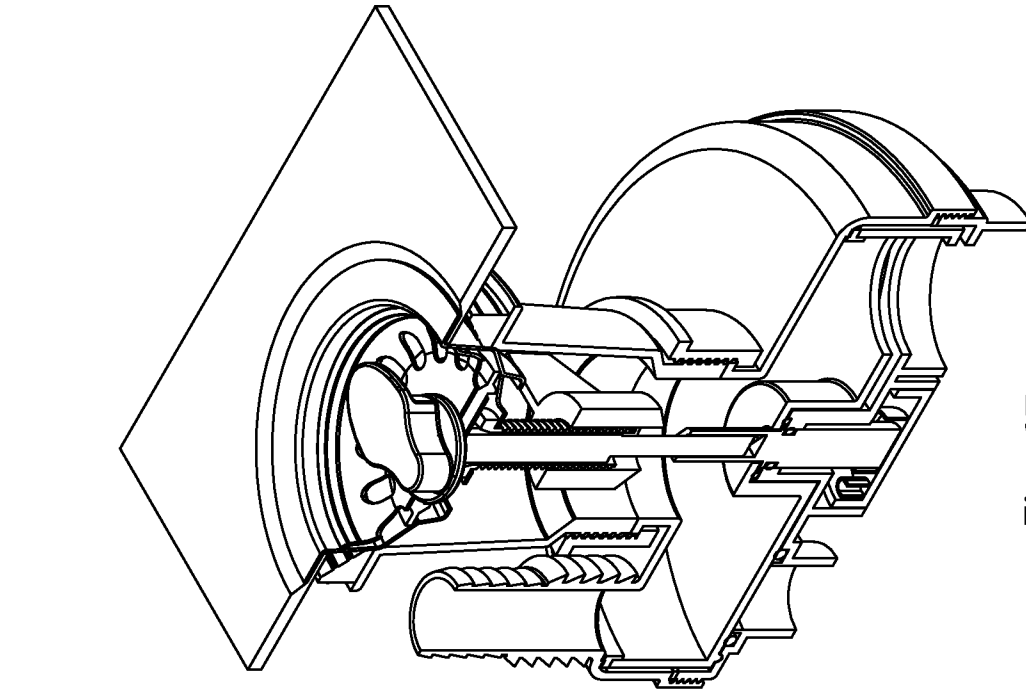

Fig. 67

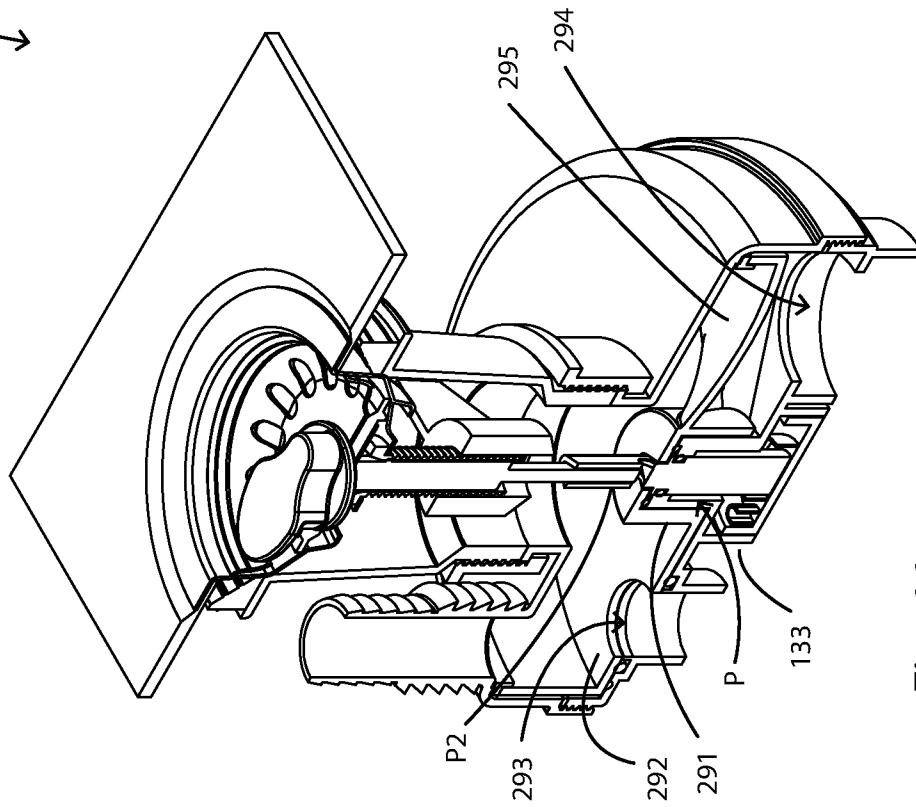
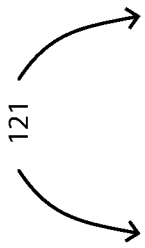

Fig. 66

# INTERNATIONAL SEARCH REPORT

International application No PCT/IB2016/057053
---

<b>A. CLASSIFICATION OF SUBJECT MATTER</b> INV. E03C1/22      E03C1/23      E03B1/04      E03C1/12 ADD.		
According to International Patent Classification (IPC) or to both national classification and IPC		
<b>B. FIELDS SEARCHED</b>		
Minimum documentation searched (classification system followed by classification symbols) E03C E03B		
Documentation searched other than minimum documentation to the extent that such documents are included in the fields searched		
Electronic data base consulted during the international search (name of data base and, where practicable, search terms used) EPO-Internal, WPI Data		
<b>C. DOCUMENTS CONSIDERED TO BE RELEVANT</b>		
Category*	Citation of document, with indication, where appropriate, of the relevant passages	Relevant to claim No.
X	GB 2 430 444 A (GEORGE ROBERT [GB]) 28 March 2007 (2007-03-28)	1, 17-20
Y	page 9; figures 1,3-6	2, 3, 5, 6
A	-----	4
X	FR 3 000 508 A1 (DAVID JOELLE [FR]) 4 July 2014 (2014-07-04)	1
Y	figures 1-3	6
Y	DE 349 419 C (BAMBERGER; LEROI & CO) 2 March 1922 (1922-03-02)	2, 3, 5, 6
Y	figure 1	
Y	US 2 348 093 A (PASMAN ABRAM N) 2 May 1944 (1944-05-02)	3
	figures 1,2	
	-----	
	-/--	
<input checked="" type="checkbox"/> Further documents are listed in the continuation of Box C. <input checked="" type="checkbox"/> See patent family annex.		
* Special categories of cited documents :		
"A" document defining the general state of the art which is not considered to be of particular relevance	"T" later document published after the international filing date or priority date and not in conflict with the application but cited to understand the principle or theory underlying the invention	
"E" earlier application or patent but published on or after the international filing date	"X" document of particular relevance; the claimed invention cannot be considered novel or cannot be considered to involve an inventive step when the document is taken alone	
"L" document which may throw doubts on priority claim(s) or which is cited to establish the publication date of another citation or other special reason (as specified)	"Y" document of particular relevance; the claimed invention cannot be considered to involve an inventive step when the document is combined with one or more other such documents, such combination being obvious to a person skilled in the art	
"O" document referring to an oral disclosure, use, exhibition or other means	"&" document member of the same patent family	
"P" document published prior to the international filing date but later than the priority date claimed		
Date of the actual completion of the international search	Date of mailing of the international search report	
28 February 2017	09/03/2017	
Name and mailing address of the ISA/ European Patent Office, P.B. 5818 Patentlaan 2 NL - 2280 HV Rijswijk Tel. (+31-70) 340-2040, Fax: (+31-70) 340-3016	Authorized officer  Isailovski, Marko	

**INTERNATIONAL SEARCH REPORT**

International application No PCT/IB2016/057053
---

C(Continuation). DOCUMENTS CONSIDERED TO BE RELEVANT

Category*	Citation of document, with indication, where appropriate, of the relevant passages	Relevant to claim No.
A	US 497 465 A (BURGOIN E.L.) 16 May 1893 (1893-05-16) figures	2
A	----- US 3 314 085 A (ANGELO MINELLA) 18 April 1967 (1967-04-18) figures -----	2,3,6

# INTERNATIONAL SEARCH REPORT

Information on patent family members

International application No PCT/IB2016/057053
---

Patent document cited in search report	Publication date	Patent family member(s)	Publication date
GB 2430444	A	CN 101268235 A	17-09-2008
		EP 1931830 A1	18-06-2008
		GB 2430444 A	28-03-2007
		JP 2009510287 A	12-03-2009
		US 2010180966 A1	22-07-2010
		WO 2007036685 A1	05-04-2007
-----			
FR 3000508	A1	04-07-2014	NONE
-----			
DE 349419	C	02-03-1922	NONE
-----			
US 2348093	A	02-05-1944	NONE
-----			
US 497465	A	16-05-1893	NONE
-----			
US 3314085	A	18-04-1967	NONE
-----			