



(11) **EP 3 098 816 A3**

(12) **EUROPEAN PATENT APPLICATION**

(88) Date of publication A3:
18.01.2017 Bulletin 2017/03

(51) Int Cl.:
G11C 16/34 (2006.01) G11C 29/50 (2006.01)
G11C 29/52 (2006.01) G11C 7/20 (2006.01)
G11C 29/42 (2006.01)

(43) Date of publication A2:
30.11.2016 Bulletin 2016/48

(21) Application number: **16169875.8**

(22) Date of filing: **17.05.2016**

(84) Designated Contracting States:
AL AT BE BG CH CY CZ DE DK EE ES FI FR GB GR HR HU IE IS IT LI LT LU LV MC MK MT NL NO PL PT RO RS SE SI SK SM TR
Designated Extension States:
BA ME
Designated Validation States:
MA MD

(72) Inventors:
• **SCOLLER, Ross**
5656 AG Eindhoven (NL)
• **CUNNINGHAM, Jeff**
5656 AG Eindhoven (NL)

(74) Representative: **Miles, John Richard**
NXP SEMICONDUCTORS
Intellectual Property Group
Abbey House
25 Clarendon Road
Redhill, Surrey RH1 1QZ (GB)

(30) Priority: **27.05.2015 US 201514722632**

(71) Applicant: **NXP USA, Inc.**
Austin TX 78735 (US)

(54) **DATA INTEGRITY CHECK WITHIN A DATA PROCESSING SYSTEM**

(57) A memory system includes a memory array, control circuitry, and comparator circuitry. The memory array includes a first section having a first plurality of programmed bitcells having a first threshold voltage distribution and a second section having a second plurality of programmed bitcells having a second threshold voltage distribution which has a lower average threshold voltage than the first threshold voltage distribution. The first plurality and second plurality of programmed bitcells are pro-

grammed with a same set of data values. The control circuitry is configured to provide a read request to the memory array and receive read data in response to the read request, wherein the read data comprises first read data from the first section and second read data from the second section. The comparator circuitry is configured to compare the first read data to the second read data and generate an error indicator in response to the compare.

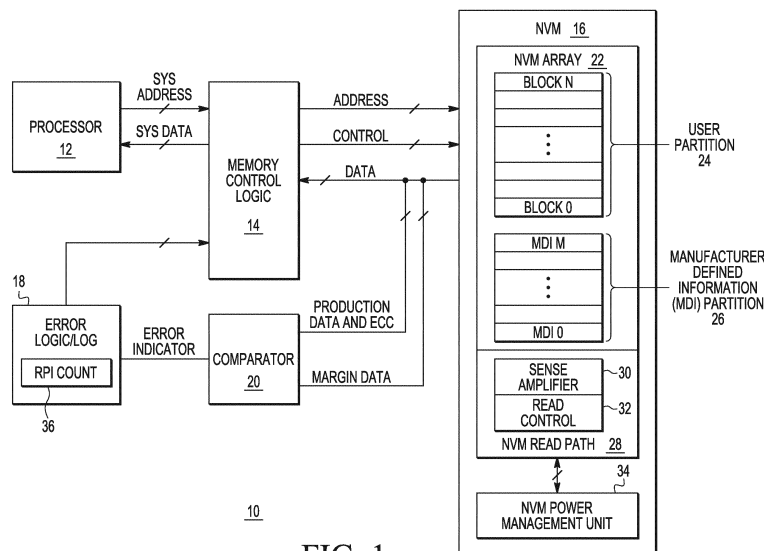

FIG. 1

EP 3 098 816 A3



EUROPEAN SEARCH REPORT

Application Number
EP 16 16 9875

5

10

15

20

25

30

35

40

45

50

55

DOCUMENTS CONSIDERED TO BE RELEVANT			
Category	Citation of document with indication, where appropriate, of relevant passages	Relevant to claim	CLASSIFICATION OF THE APPLICATION (IPC)
X A	US 6 778 442 B1 (HAMILTON DARLENE G [US] ET AL) 17 August 2004 (2004-08-17) * figure 7 *	1 12-15	INV. G11C16/34 G11C29/50 G11C29/52 G11C7/20 G11C29/42
A	US 2014/281750 A1 (JEON SEUNGJUNE [US] ET AL) 18 September 2014 (2014-09-18) * paragraph [0004]; figures 1,4 *	1-15	
A	US 2011/216598 A1 (KIM JAEHONG [KR] ET AL) 8 September 2011 (2011-09-08) * paragraph [0012] *	1-15	
The present search report has been drawn up for all claims			TECHNICAL FIELDS SEARCHED (IPC)
			G11C
Place of search		Date of completion of the search	Examiner
The Hague		8 December 2016	Wolff, Norbert
CATEGORY OF CITED DOCUMENTS			
X : particularly relevant if taken alone Y : particularly relevant if combined with another document of the same category A : technological background O : non-written disclosure P : intermediate document		T : theory or principle underlying the invention E : earlier patent document, but published on, or after the filing date D : document cited in the application L : document cited for other reasons & : member of the same patent family, corresponding document	

EPO FORM 1503 03/02 (P04C01)

ANNEX TO THE EUROPEAN SEARCH REPORT
ON EUROPEAN PATENT APPLICATION NO.

EP 16 16 9875

5 This annex lists the patent family members relating to the patent documents cited in the above-mentioned European search report.
The members are as contained in the European Patent Office EDP file on
The European Patent Office is in no way liable for these particulars which are merely given for the purpose of information.

08-12-2016

Patent document cited in search report	Publication date	Patent family member(s)	Publication date
US 6778442 B1	17-08-2004	CN 1777959 A	24-05-2006
		DE 112004000703 T5	24-05-2006
		GB 2415552 A	28-12-2005
		GB 2427771 A	03-01-2007
		JP 5281599 B2	04-09-2013
		JP 2007524953 A	30-08-2007
		JP 2010102828 A	06-05-2010
		KR 20060008916 A	27-01-2006
		TW 1326875 B	01-07-2010
		US 6778442 B1	17-08-2004
WO 2004097837 A2	11-11-2004		
US 2014281750 A1	18-09-2014	US 2014281750 A1	18-09-2014
		US 2014281772 A1	18-09-2014
		WO 2014164134 A2	09-10-2014
US 2011216598 A1	08-09-2011	KR 20110099566 A	08-09-2011
		US 2011216598 A1	08-09-2011
		US 2014056064 A1	27-02-2014