



US 20140253993A1

(19) **United States**

(12) **Patent Application Publication**
Lapstun

(10) **Pub. No.: US 2014/0253993 A1**

(43) **Pub. Date: Sep. 11, 2014**

(54) **LIGHT FIELD DISPLAY WITH MEMS SCANNERS**

(52) **U.S. Cl.**
CPC *G02B 26/101* (2013.01); *G02B 26/0833* (2013.01); *G02B 26/085* (2013.01)
USPC **359/199.3**; 359/199.4

(71) Applicant: **Paul Lapstun**, Rodd Point (AU)

(72) Inventor: **Paul Lapstun**, Rodd Point (AU)

(21) Appl. No.: **14/286,986**

(22) Filed: **May 24, 2014**

Related U.S. Application Data

(63) Continuation of application No. 13/567,010, filed on Aug. 4, 2012, now Pat. No. 8,754,829.

Publication Classification

(51) **Int. Cl.**
G02B 26/10 (2006.01)
G02B 26/08 (2006.01)

(57) **ABSTRACT**

A light field display device comprising an array of light field display elements, each display element comprising: a beam generator for generating an output beam of light; a radiance modulator for modulating the radiance of the beam over time; a focus modulator for modulating the focus of the beam over time; and a scanner for scanning the beam across a two-dimensional angular field, the scanner comprising a biaxial electromechanical scanning mirror comprising: a mirror, a platform, an inner frame, and an outer frame; the mirror attached to the platform via a post, the platform attached to the inner frame via a first pair of hinges, and the inner frame attached to the outer frame via a second pair of hinges; the first pair of hinges arranged substantially orthogonally to the second pair of hinges, thereby to allow biaxial movement of the mirror; the extent of the mirror larger than the extent of the inner frame.

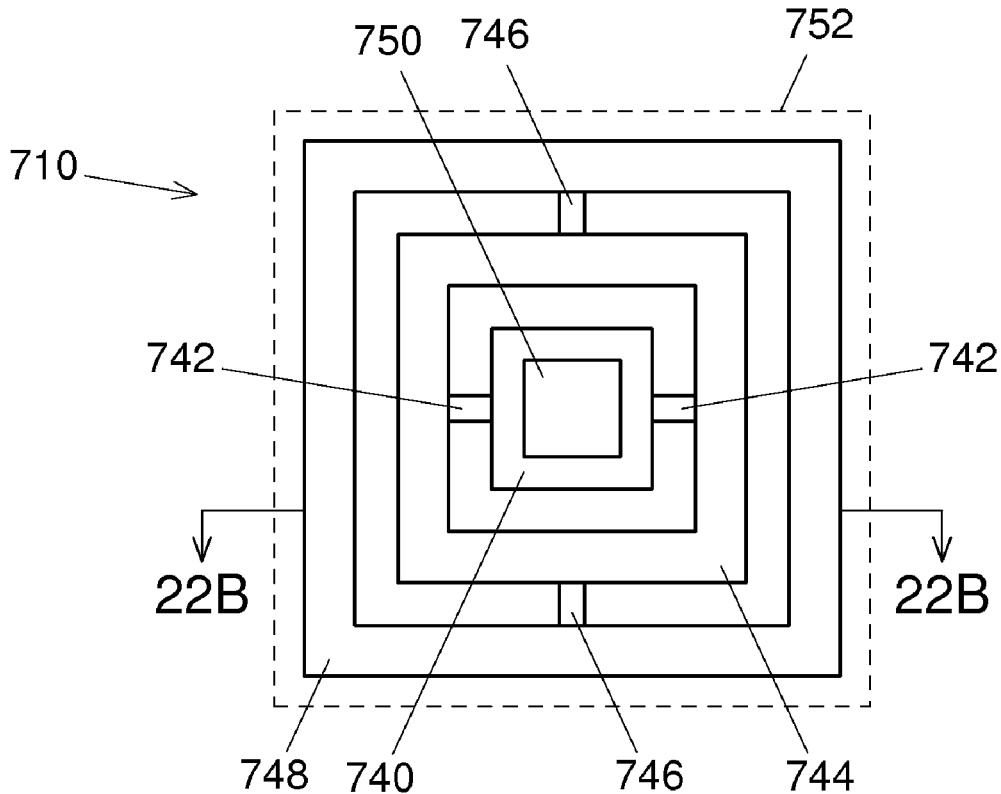

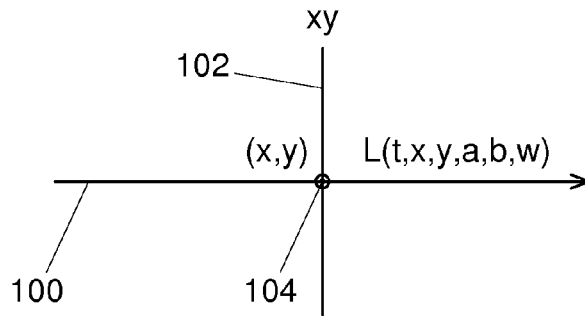

Fig. 1A

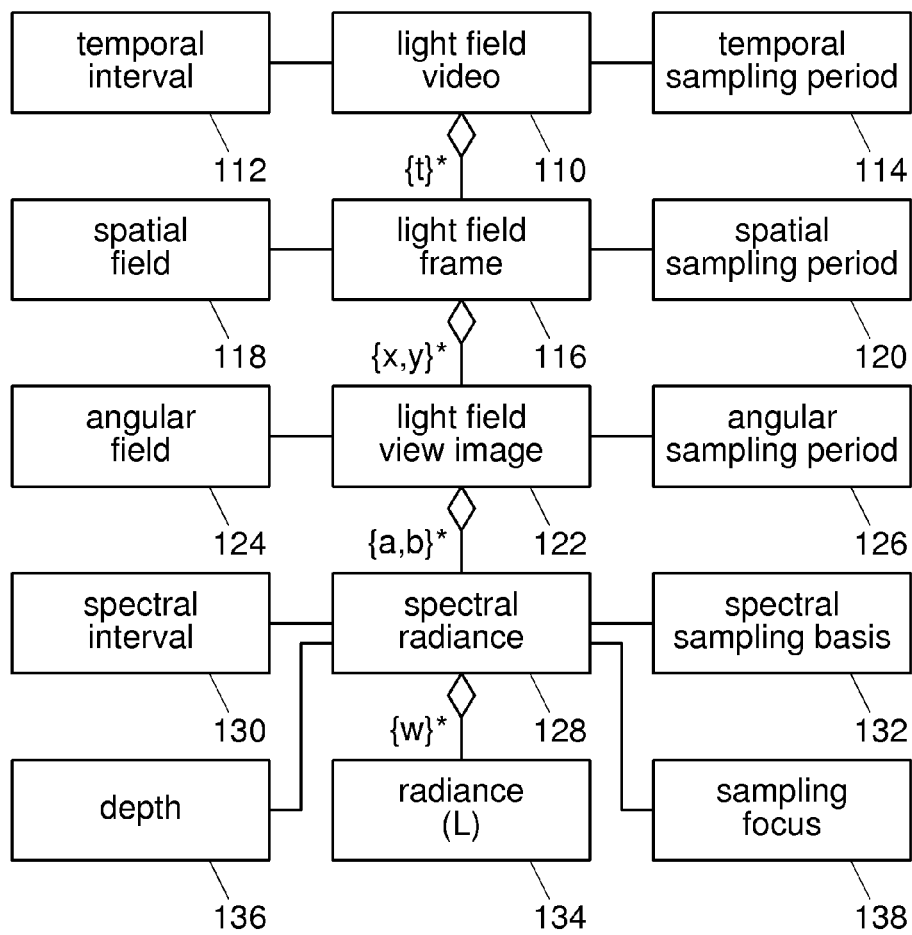

Fig. 1B

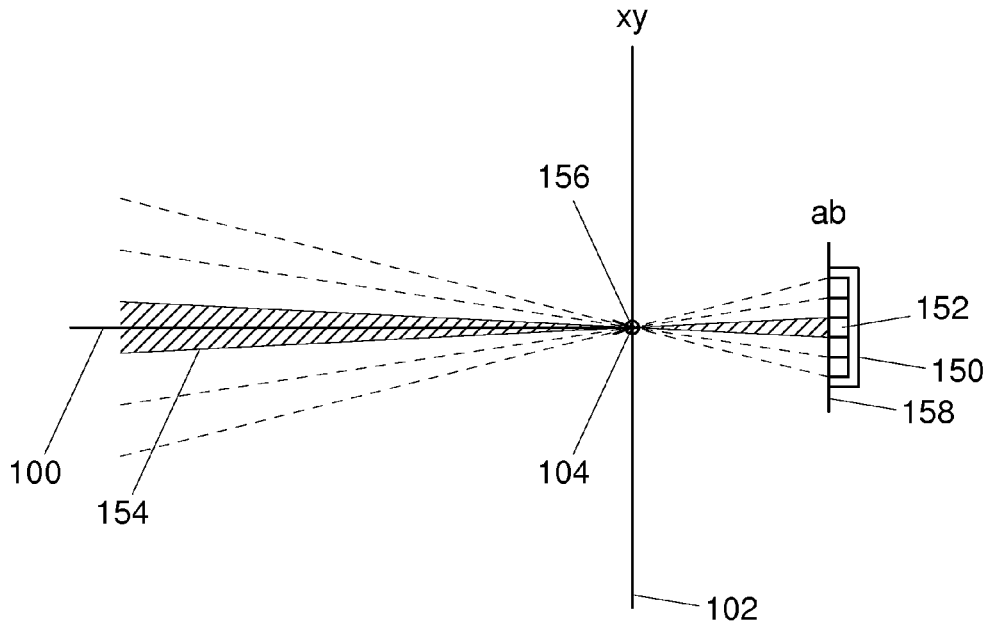

Fig. 2A

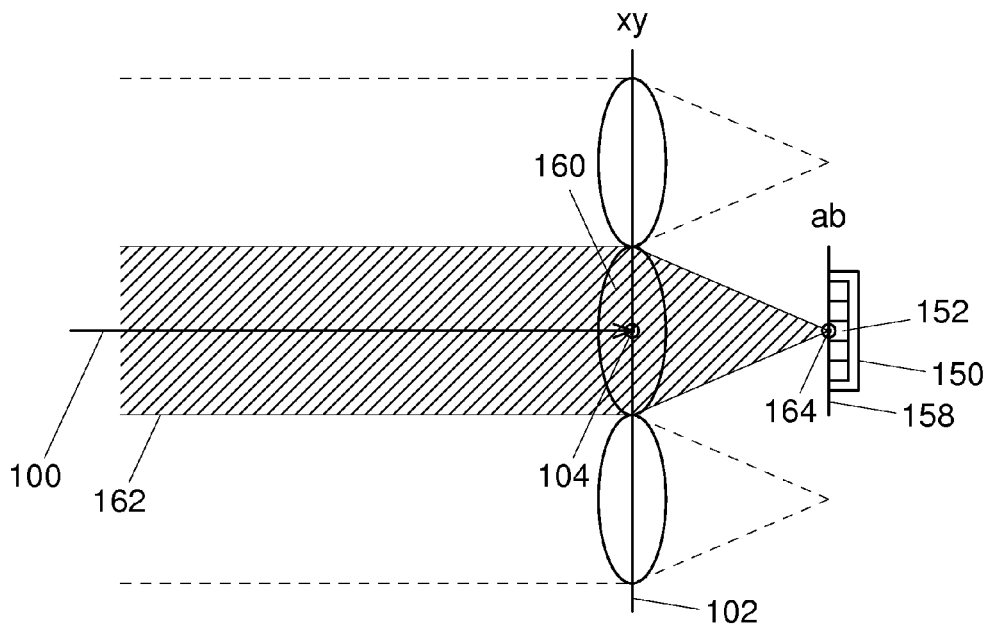

Fig. 2B

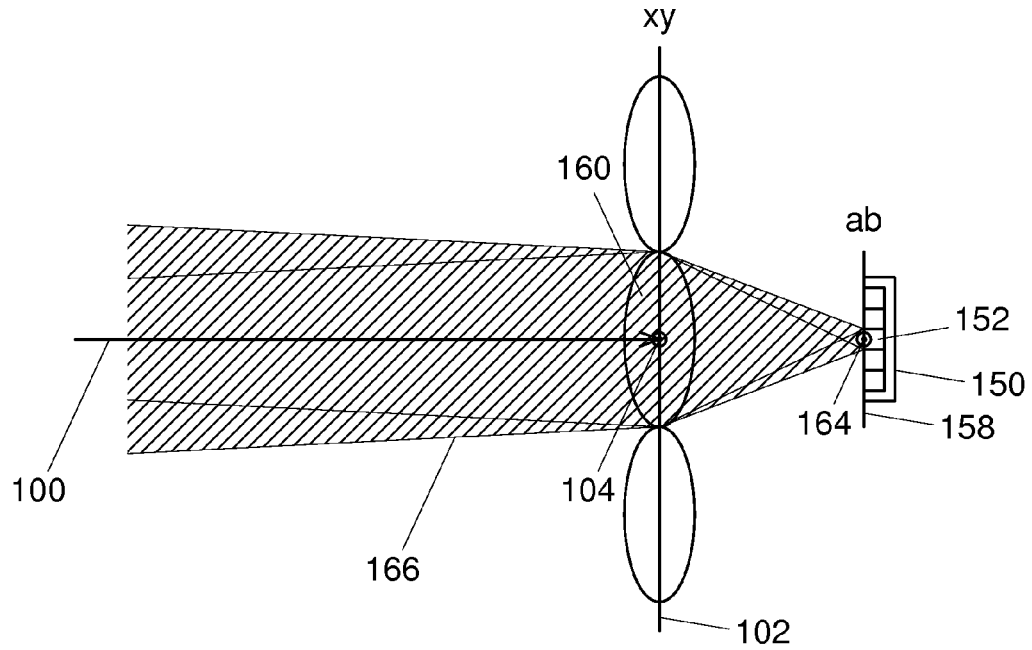

Fig. 3A

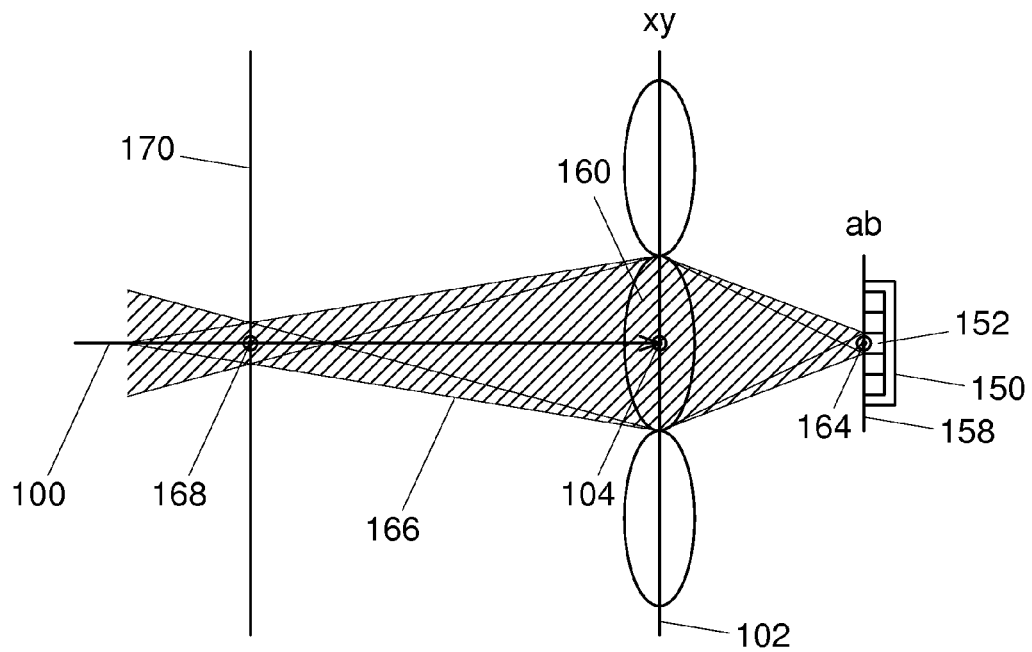

Fig. 3B

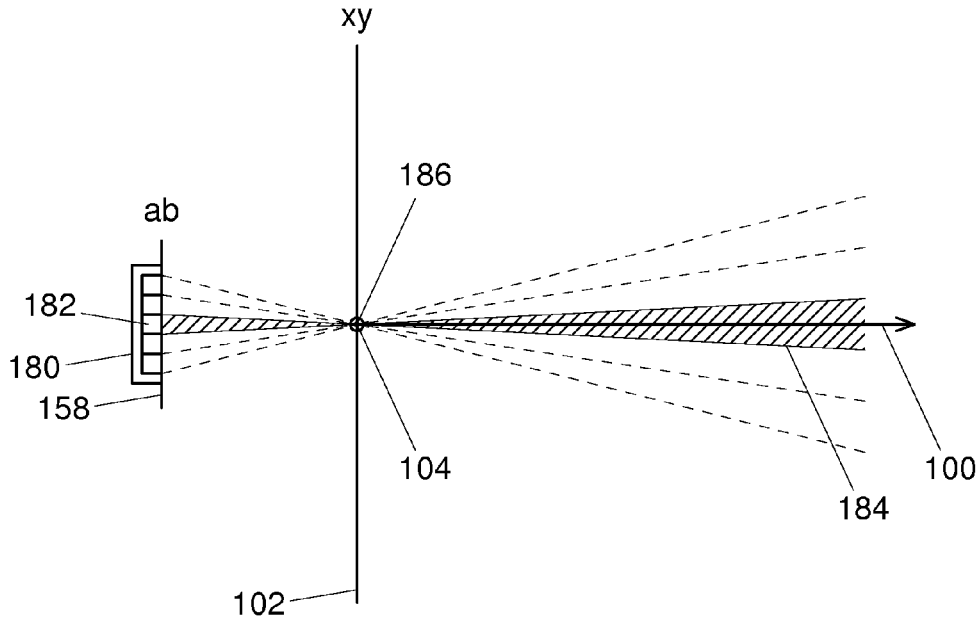

Fig. 4A

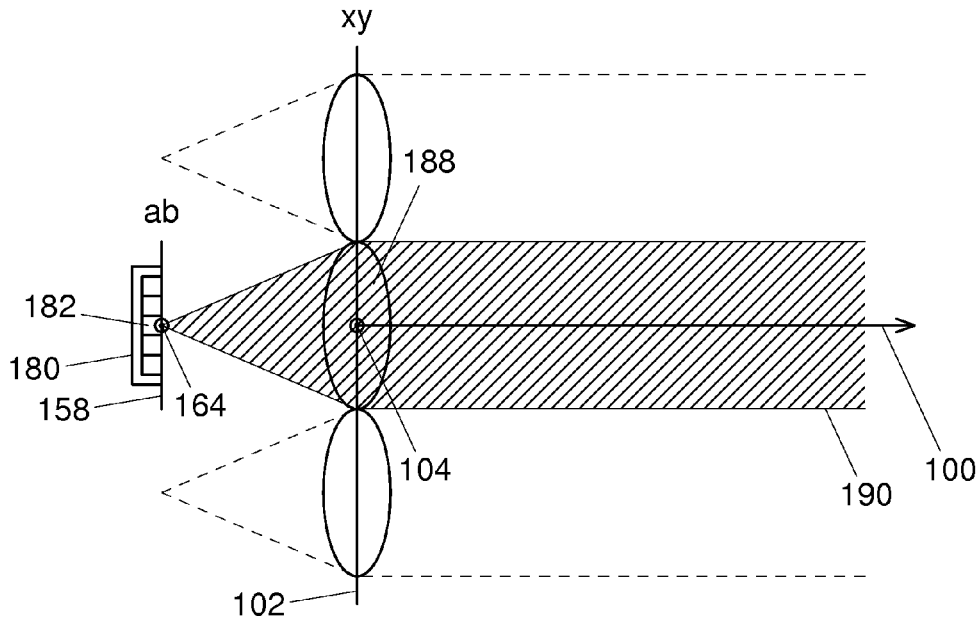

Fig. 4B

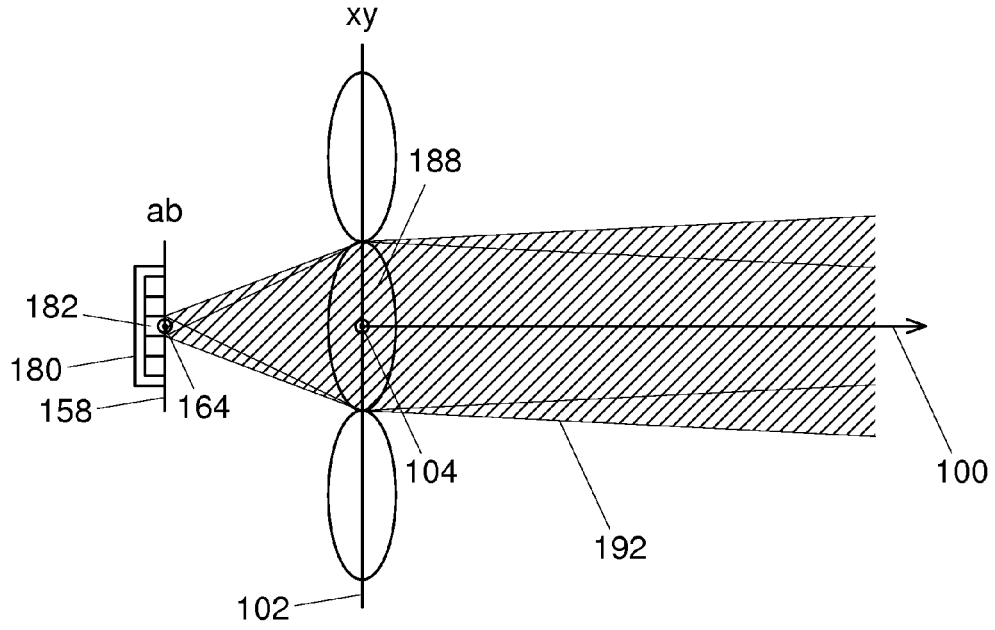

Fig. 5A

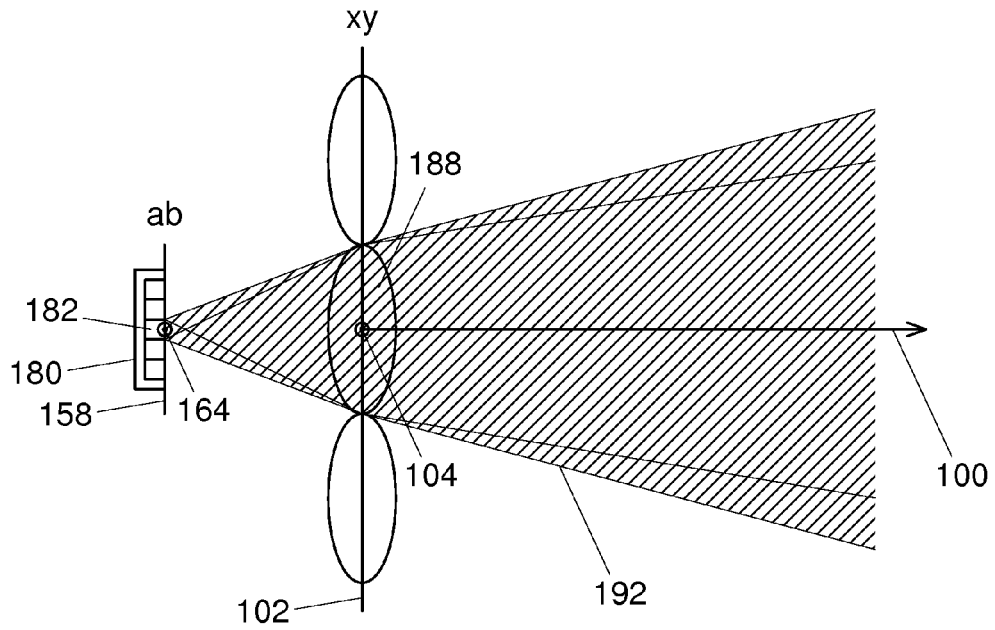

Fig. 5B

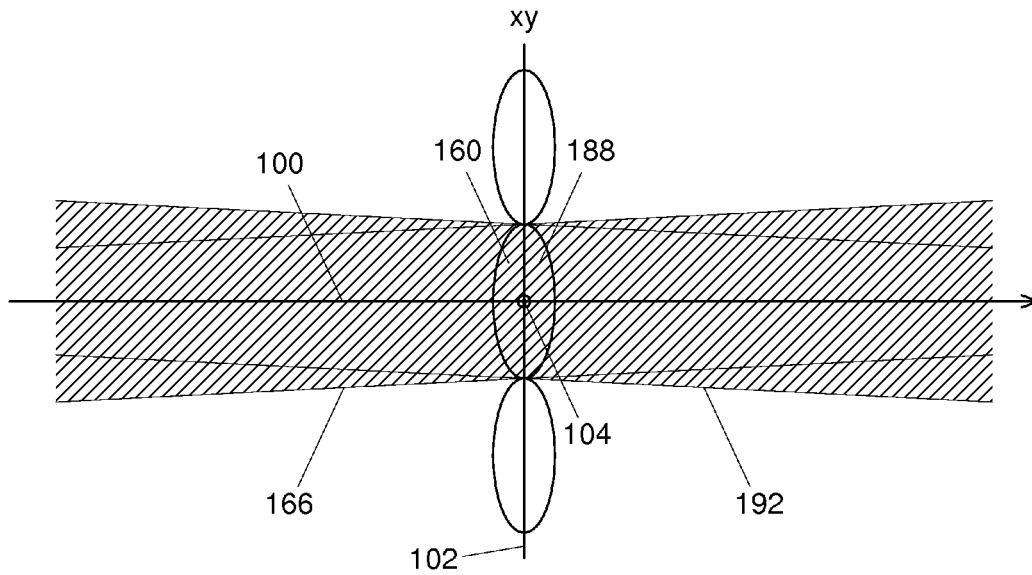

Fig. 6A

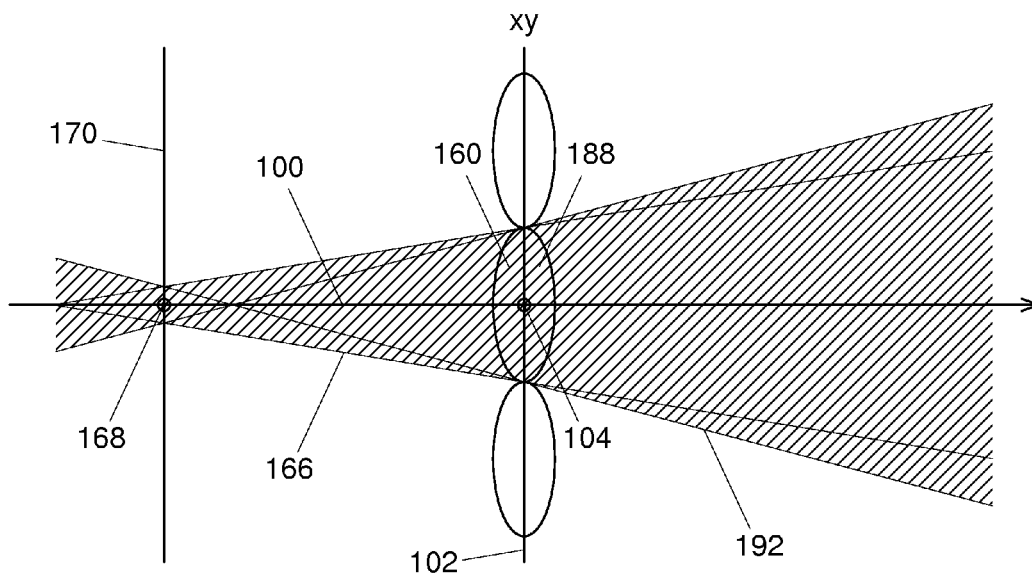

Fig. 6B

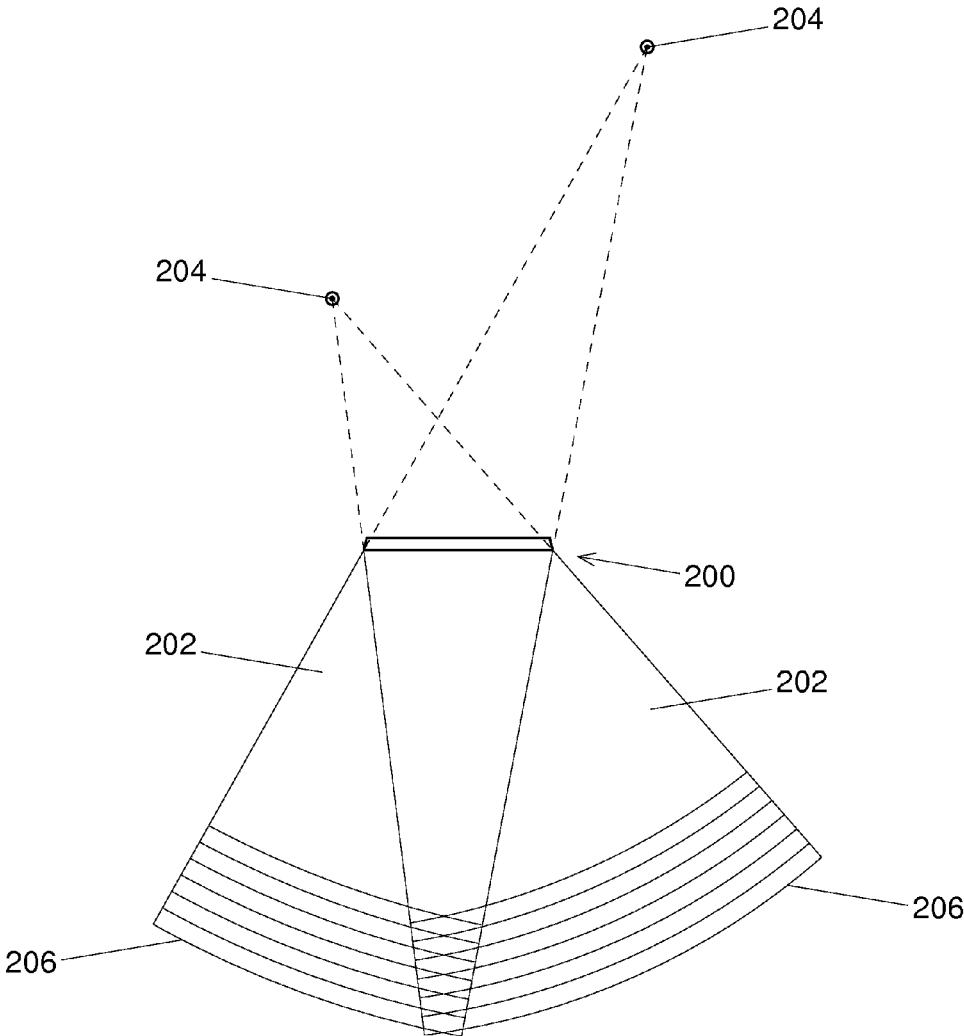

Fig. 7A

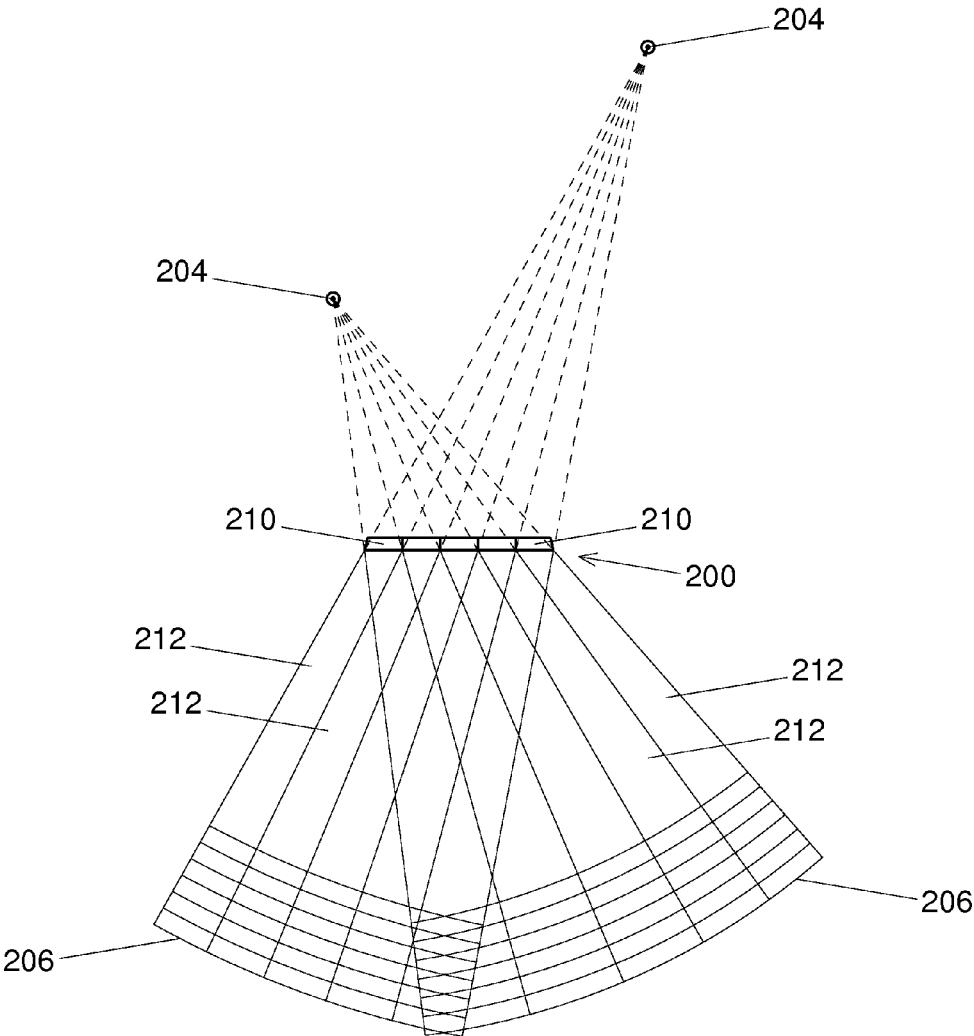

Fig. 7B

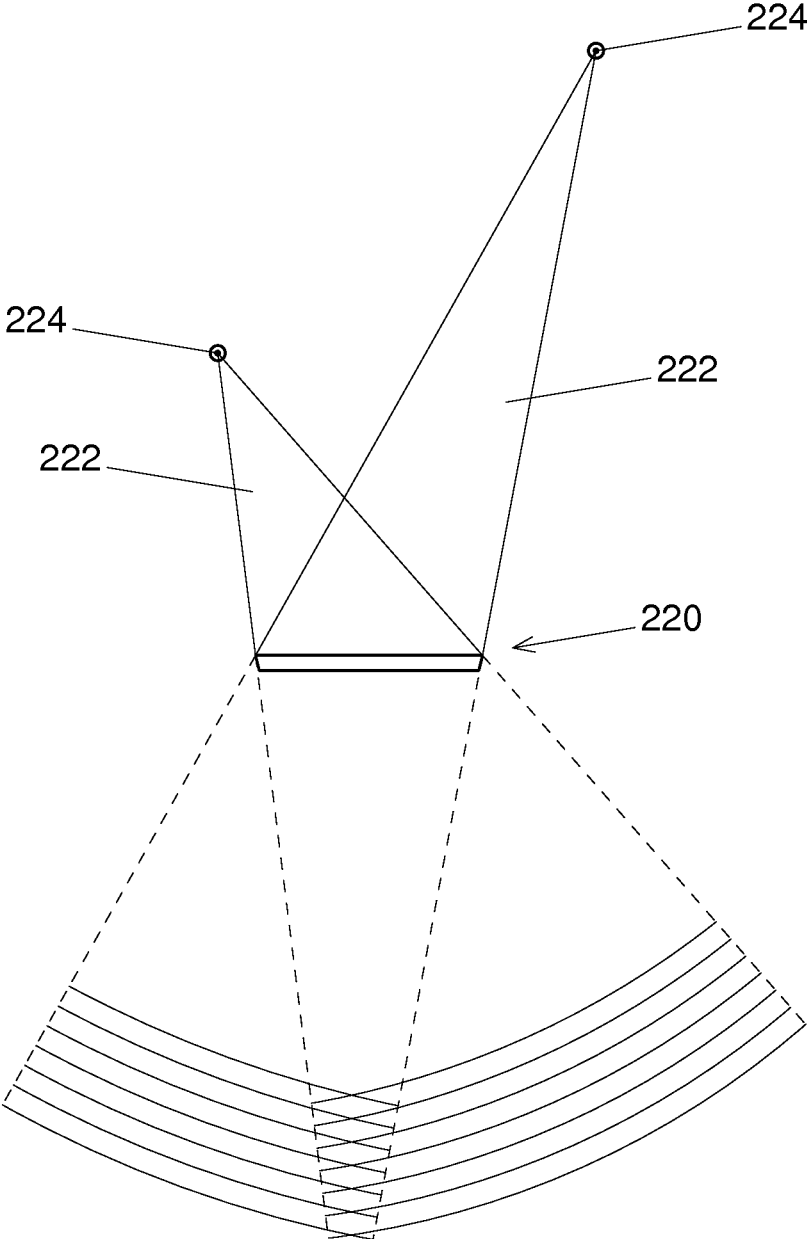

Fig. 8A

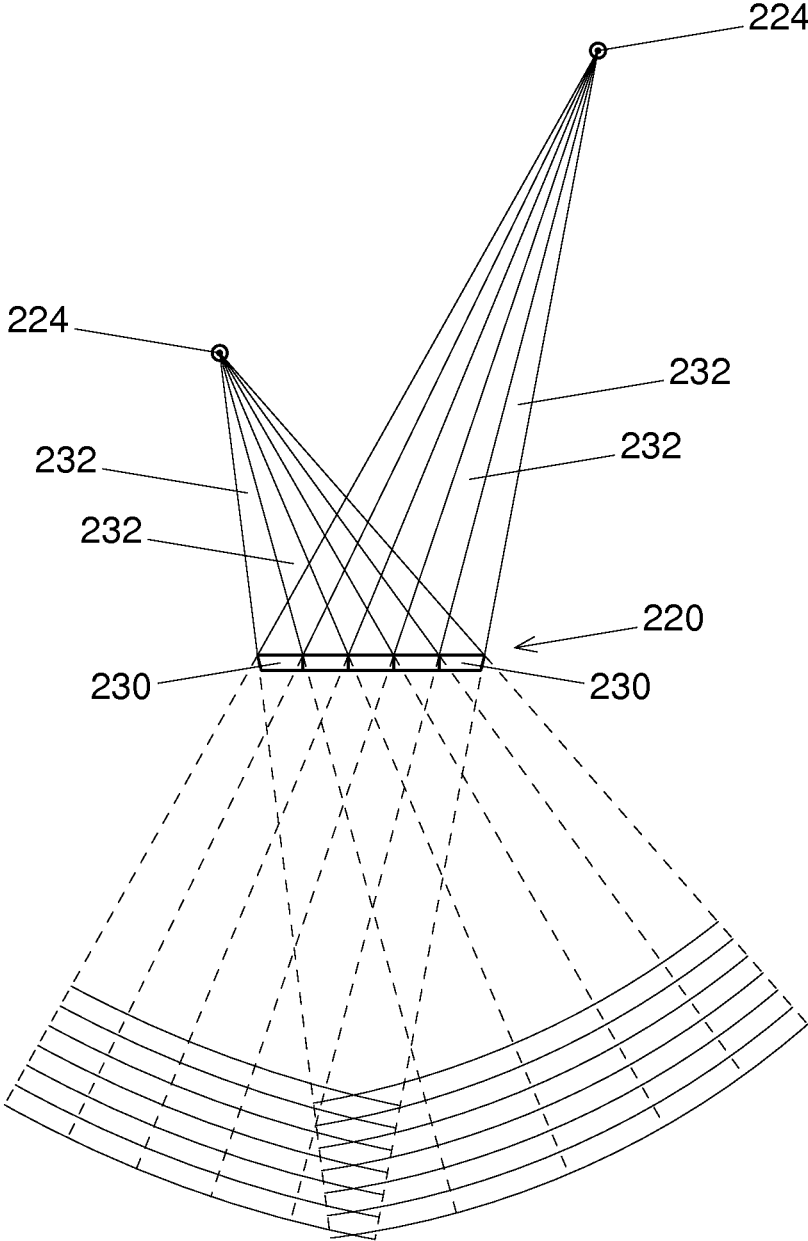

Fig. 8B

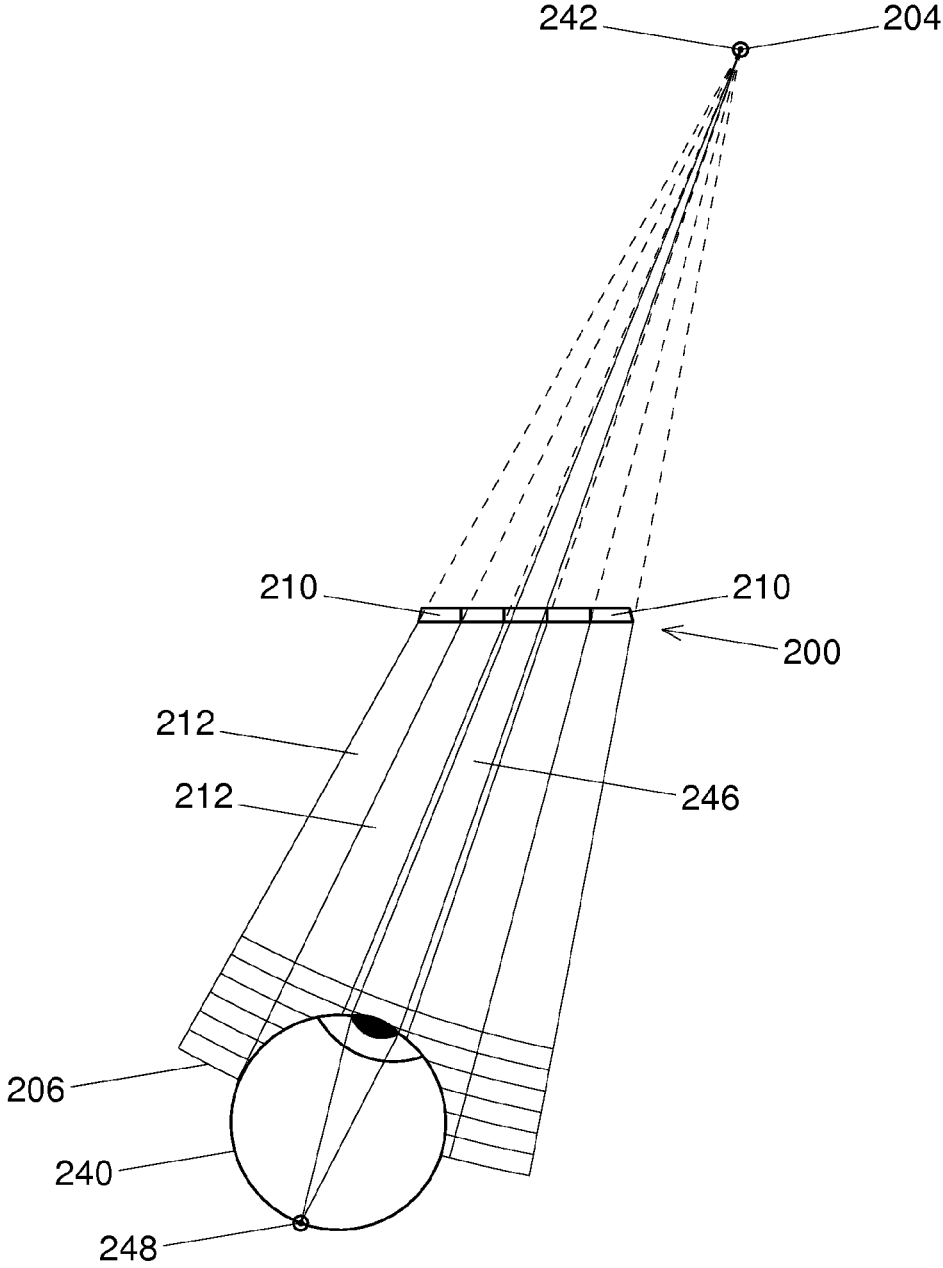

Fig. 9A

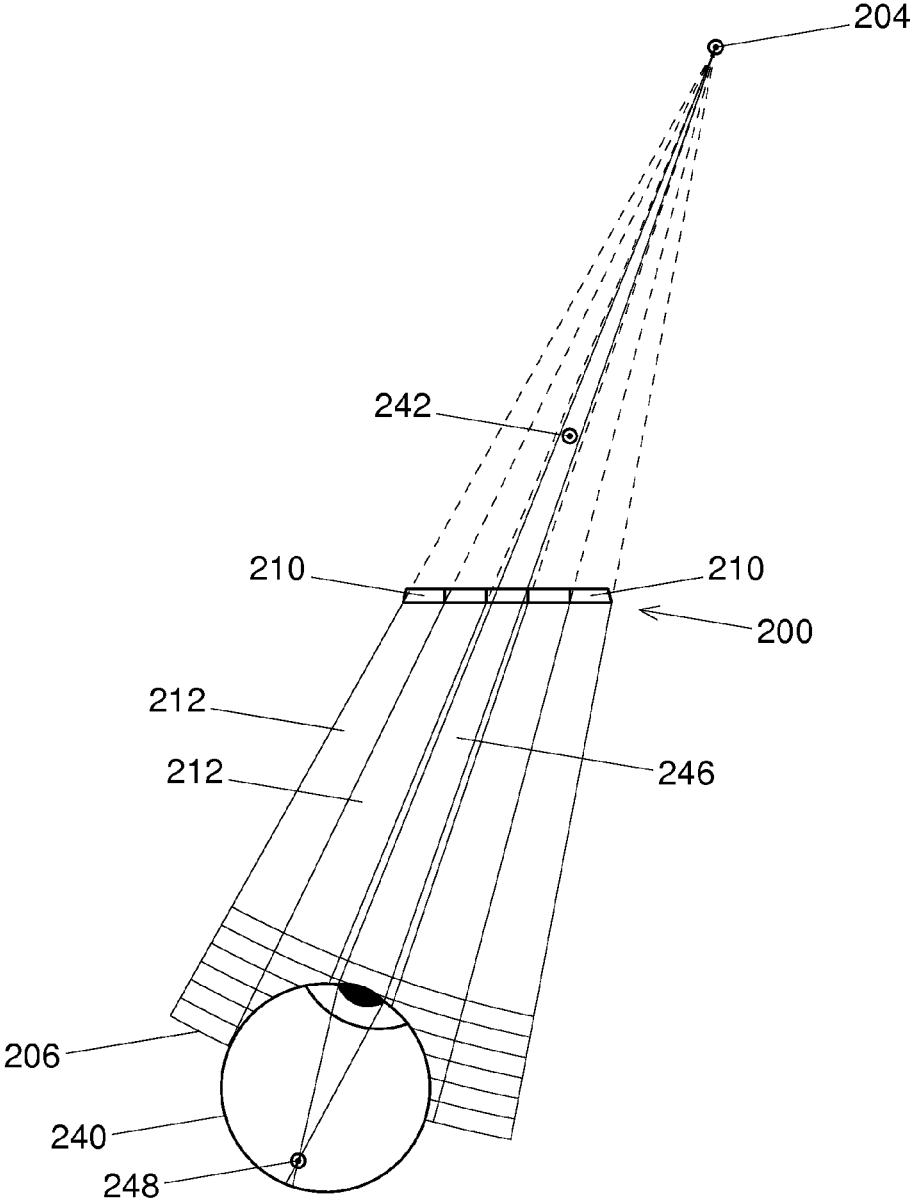

Fig. 9B

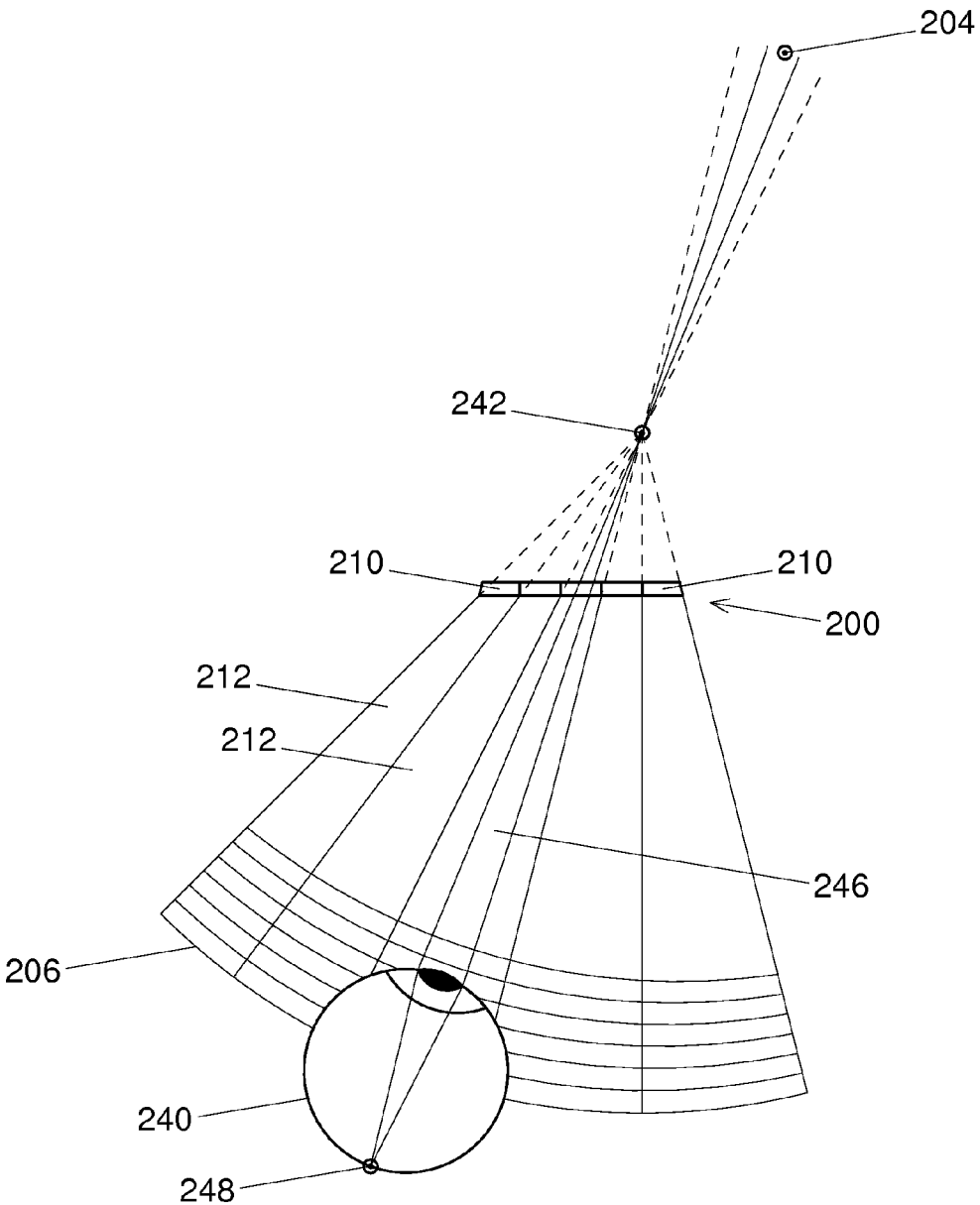

Fig. 9C

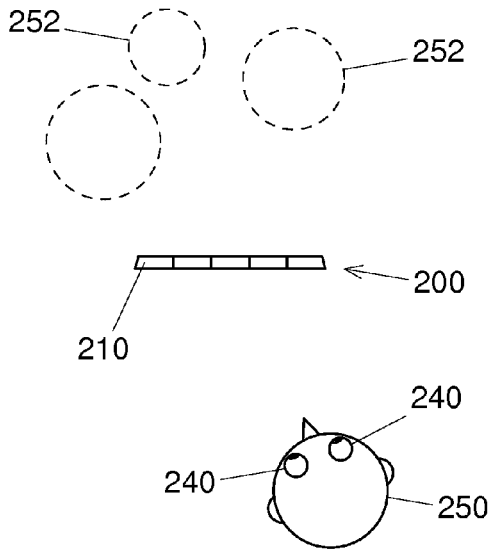

Fig. 10A

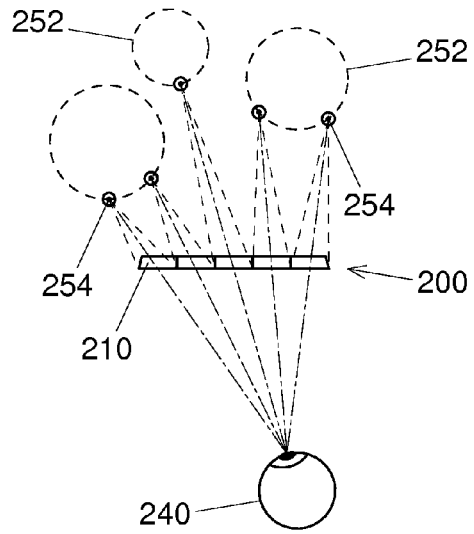

Fig. 10B

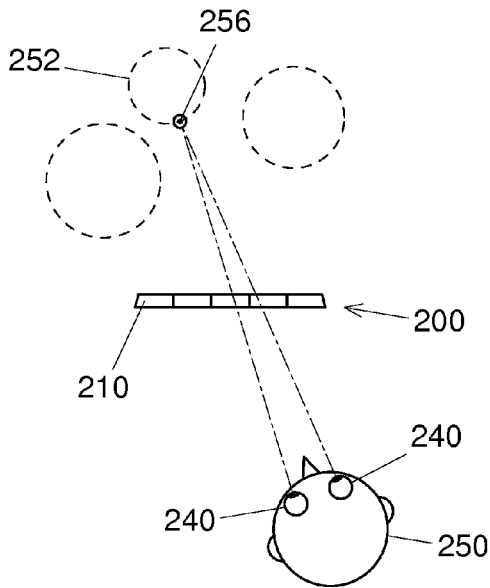

Fig. 10C

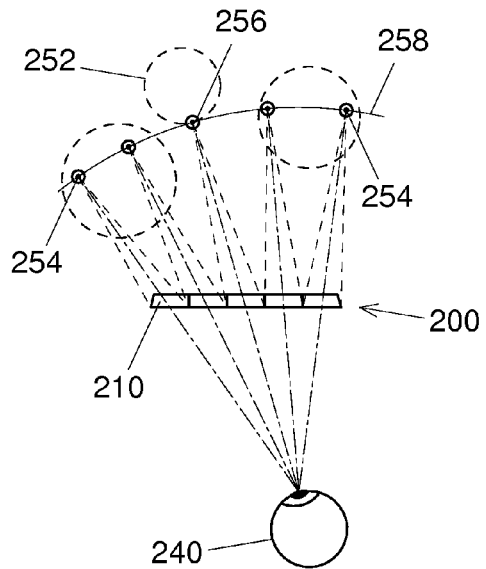

Fig. 10D

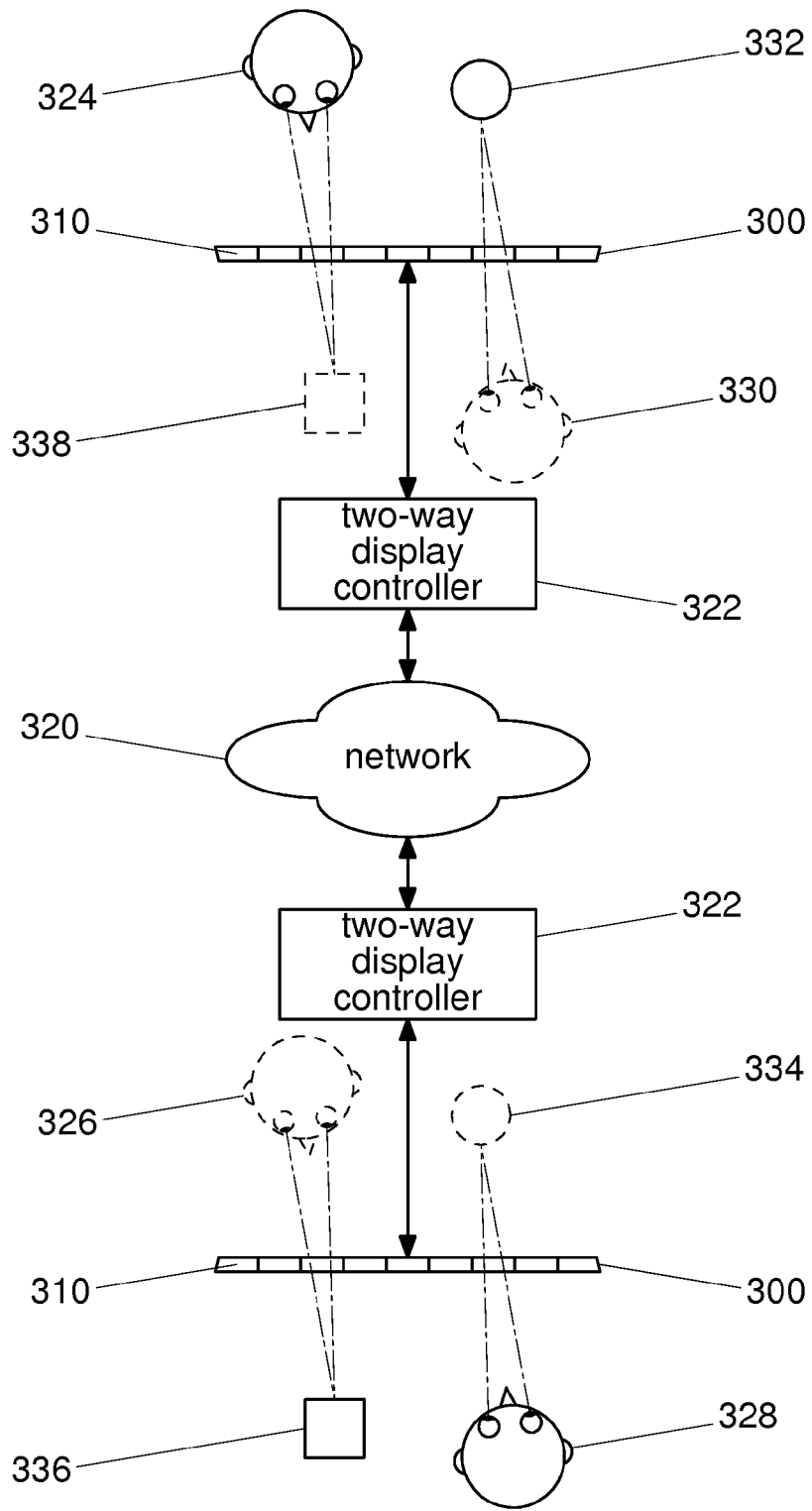

Fig. 11

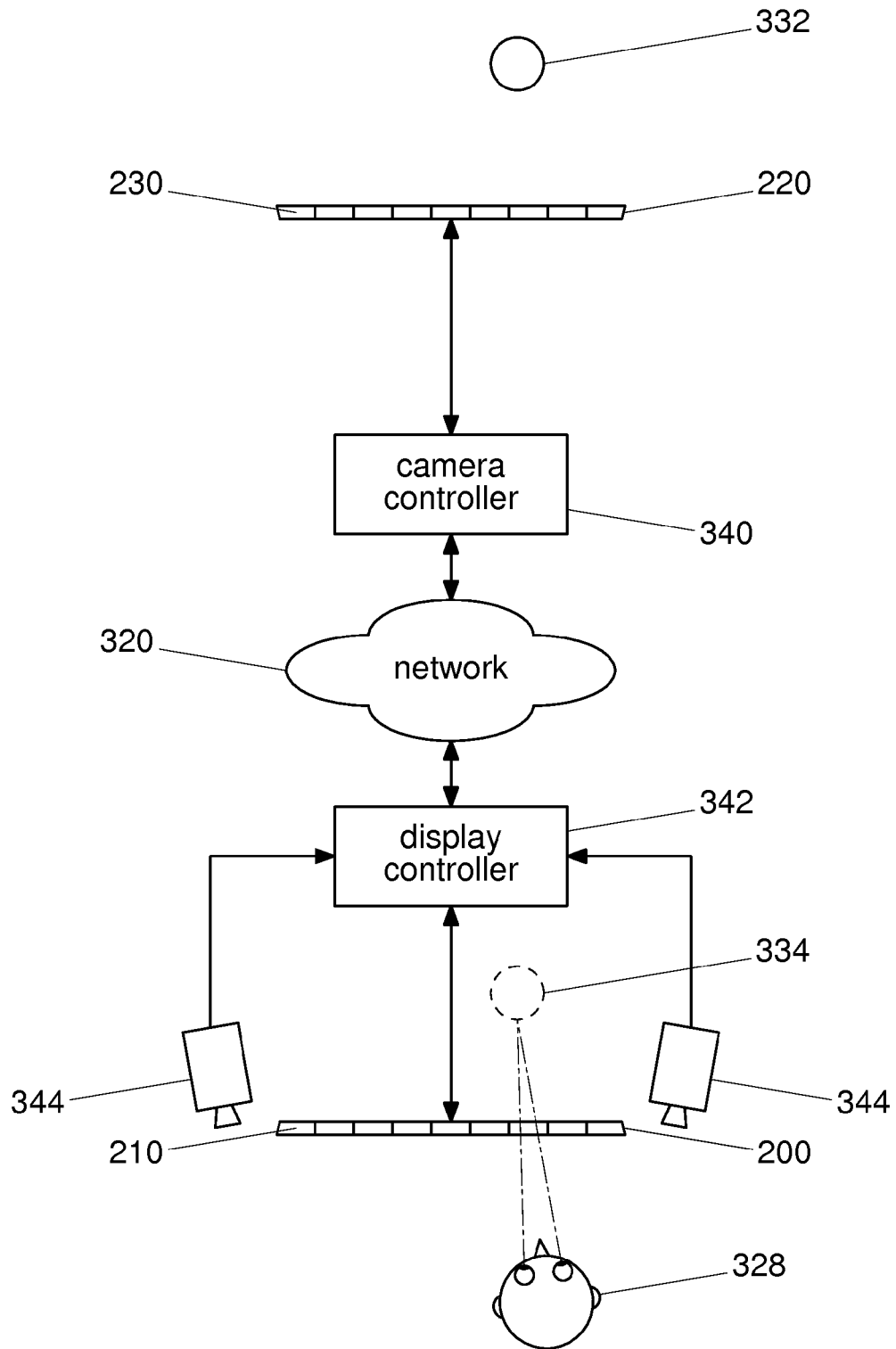

Fig. 12

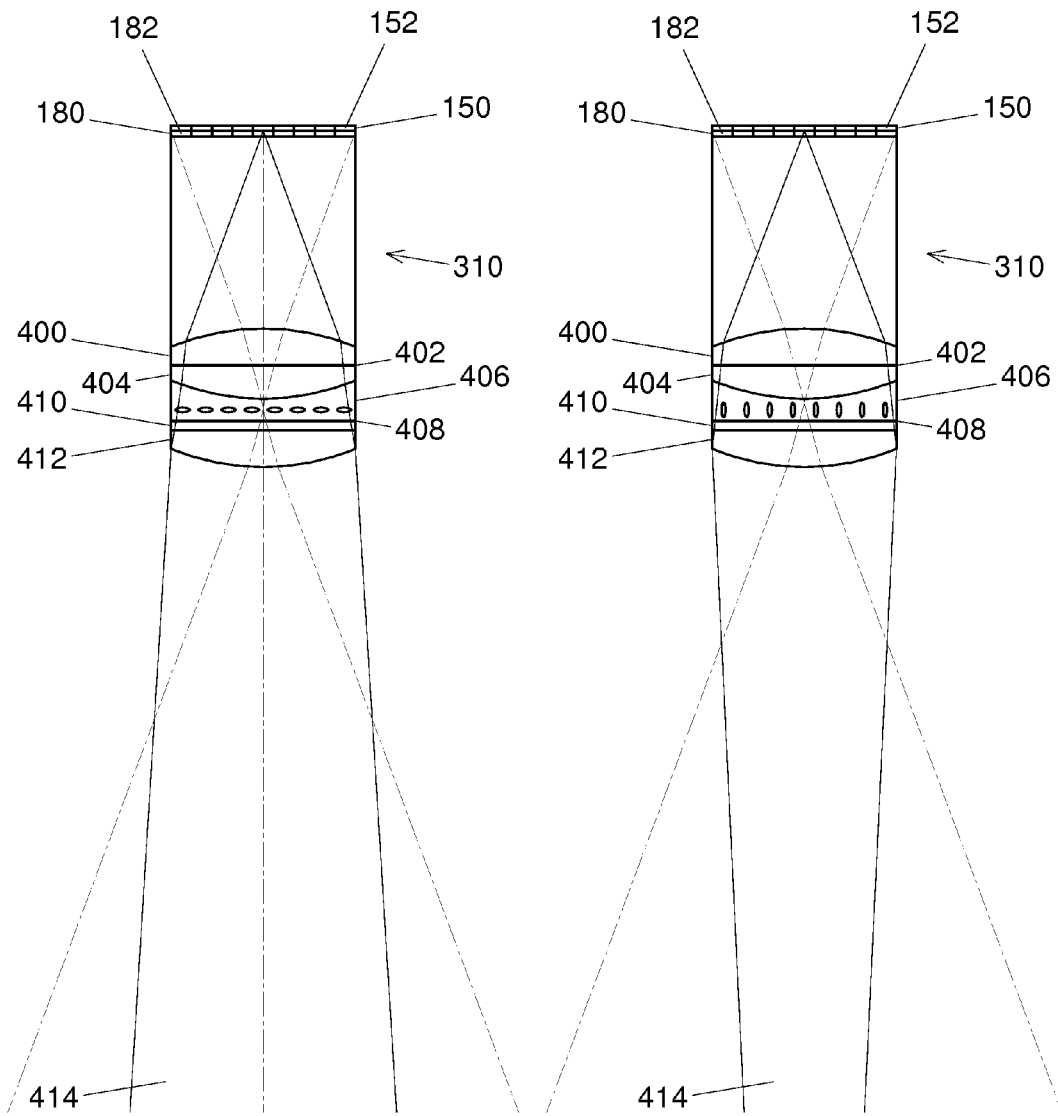

Fig. 13A

Fig. 13B

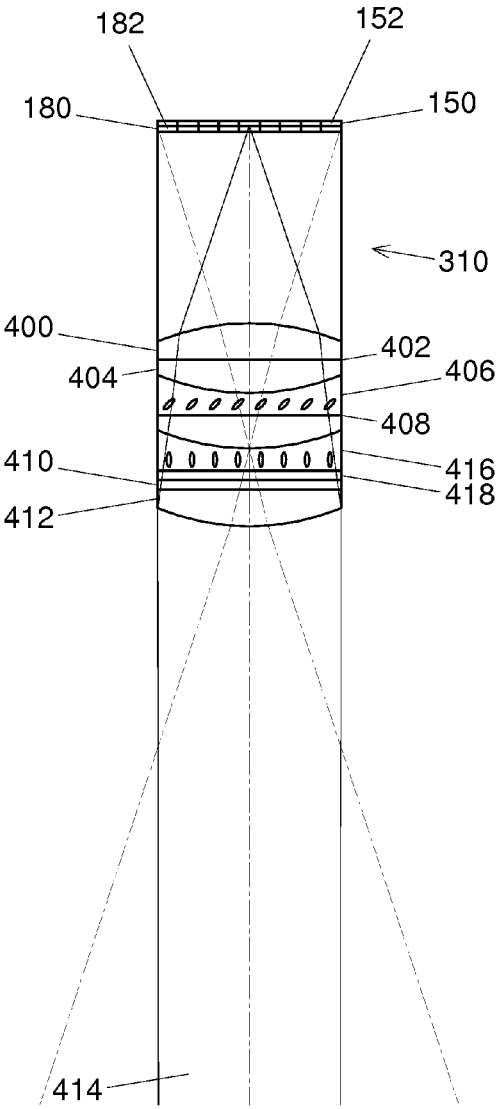

Fig. 14A

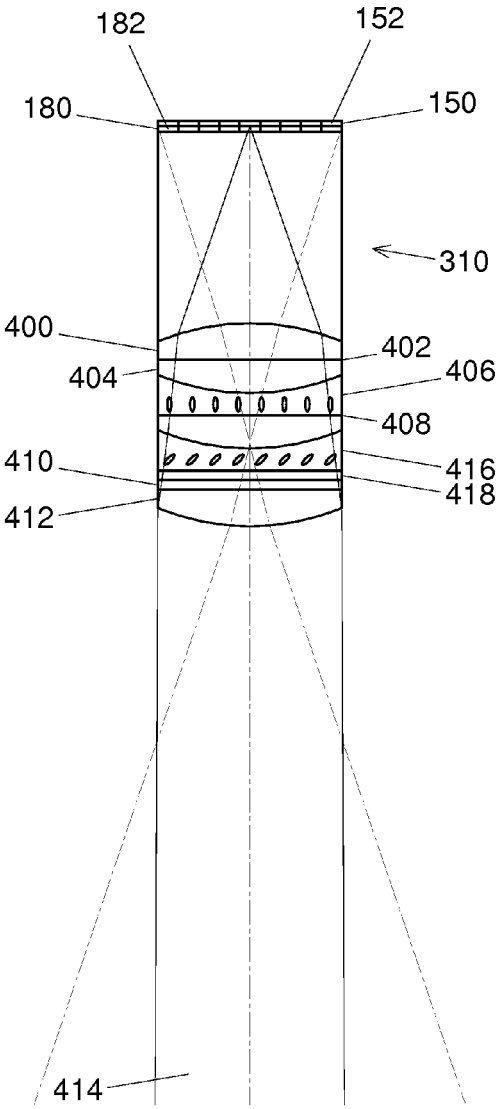

Fig. 14B

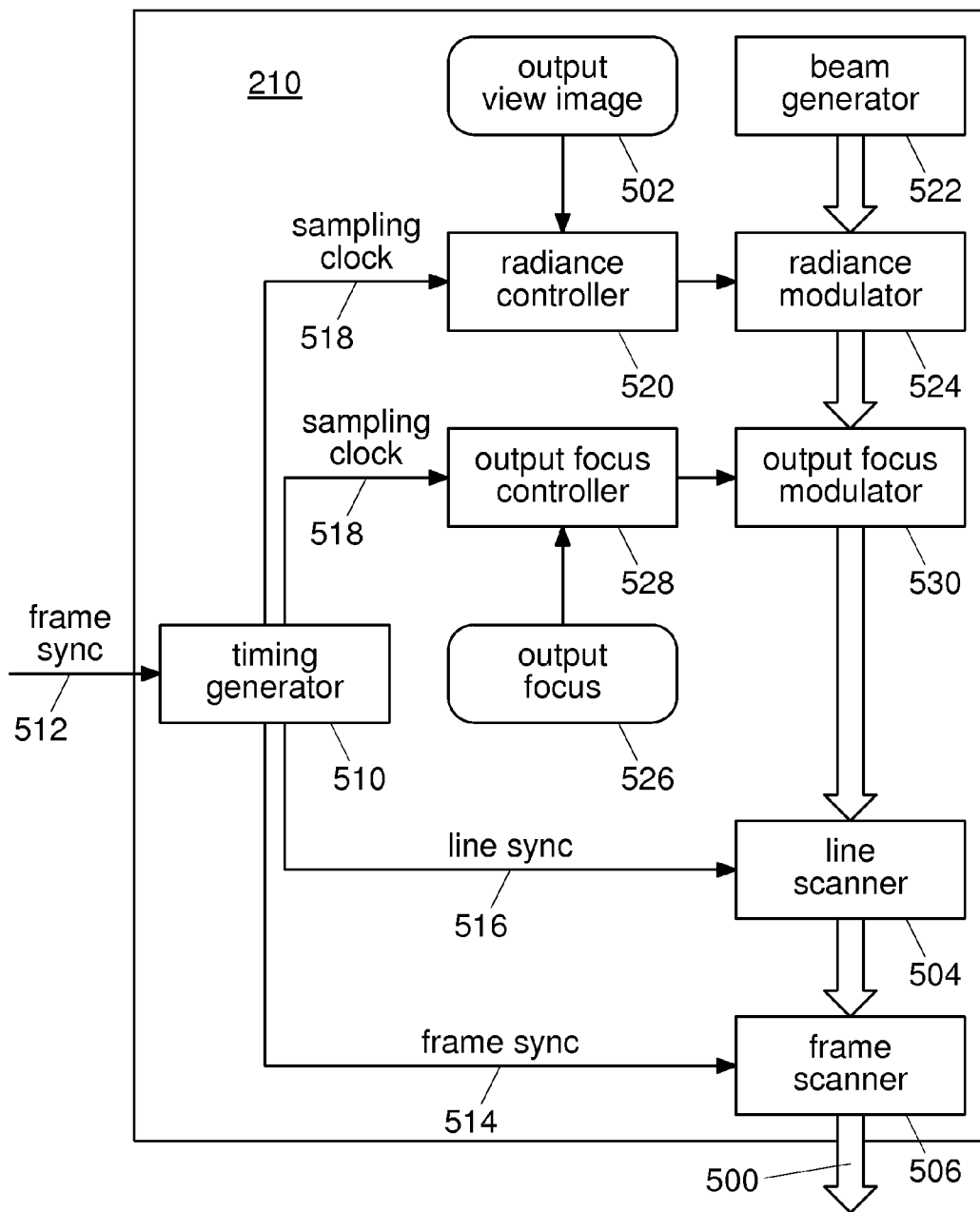

Fig. 15

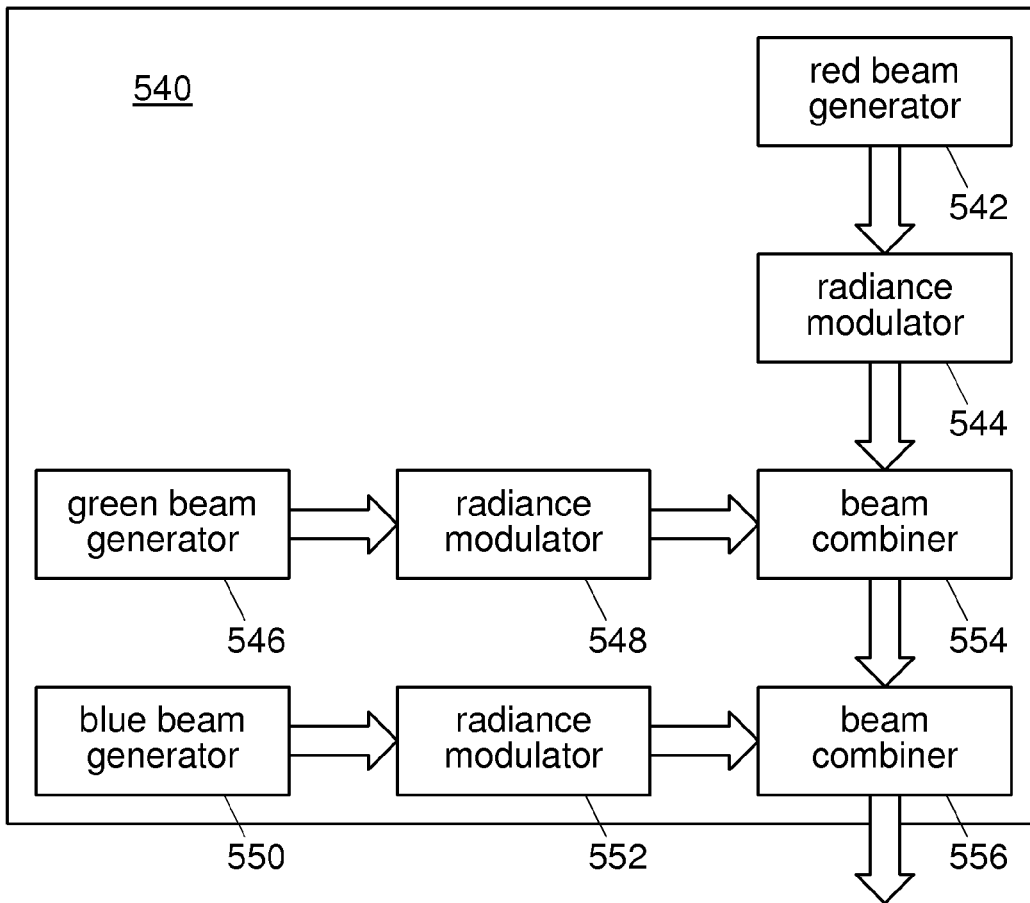

Fig. 16

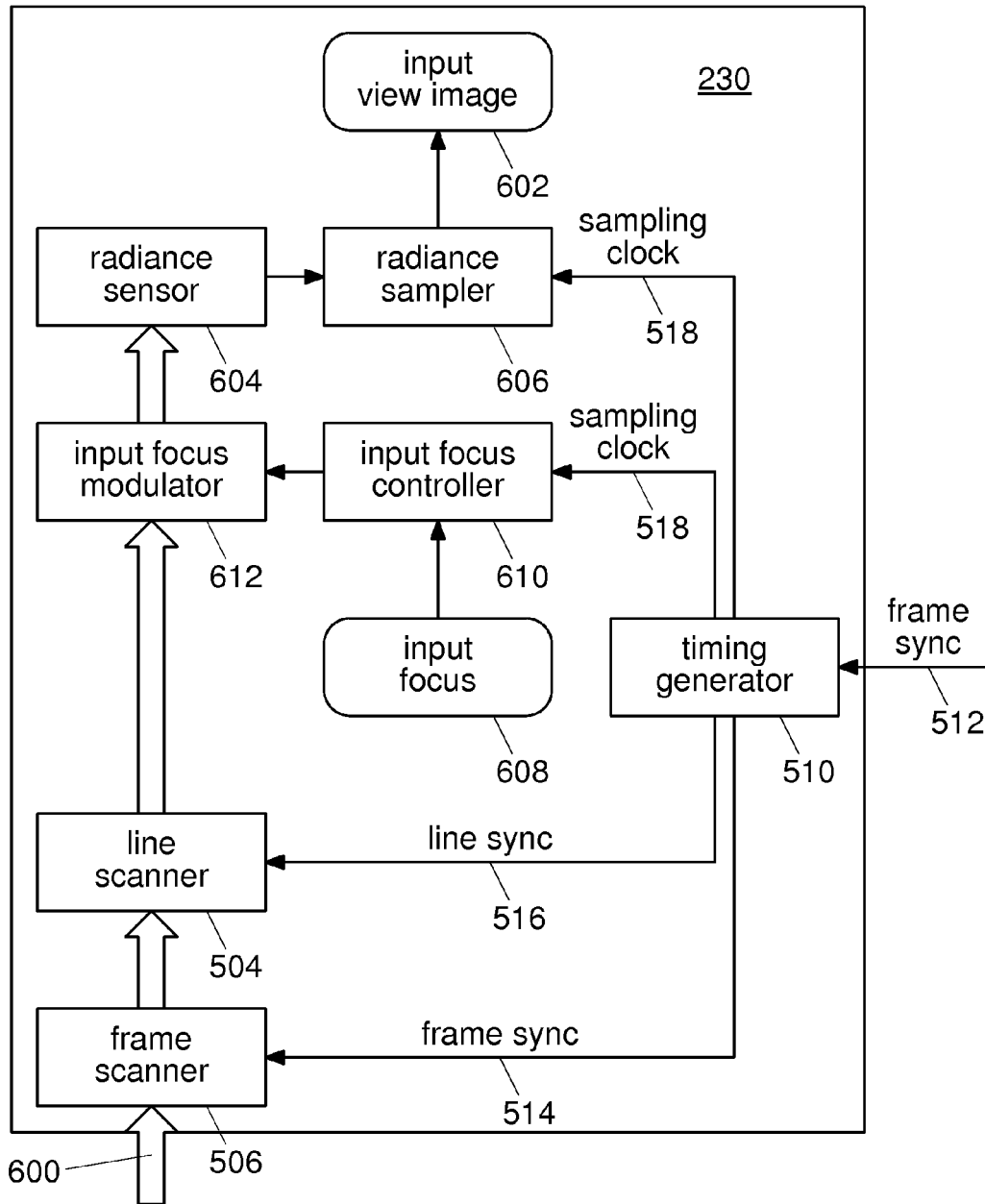

Fig. 17

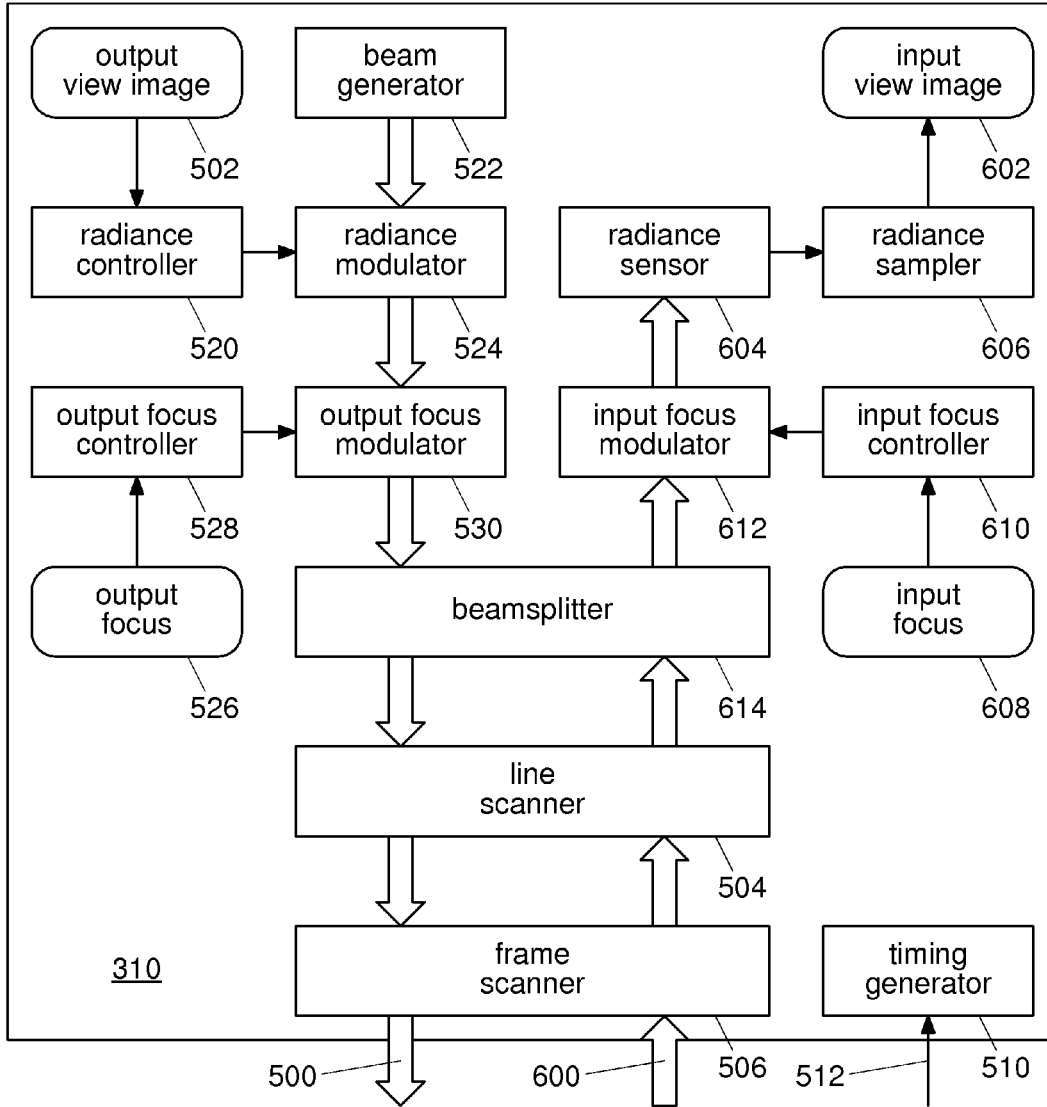

Fig. 18

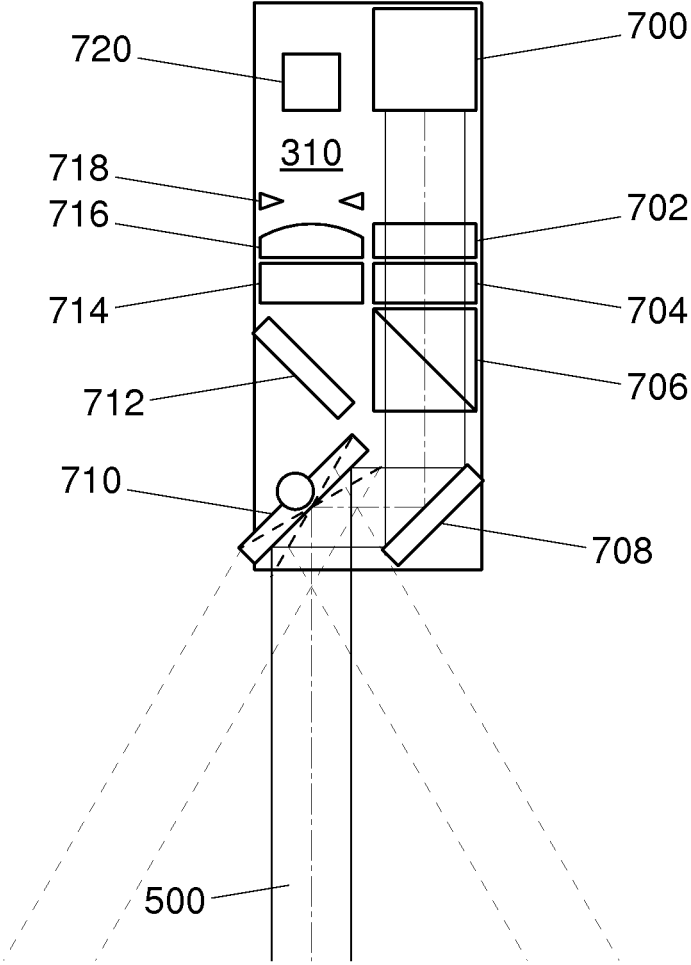

Fig. 19A

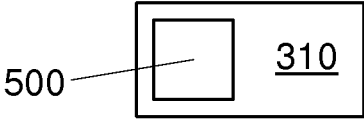

Fig. 19B

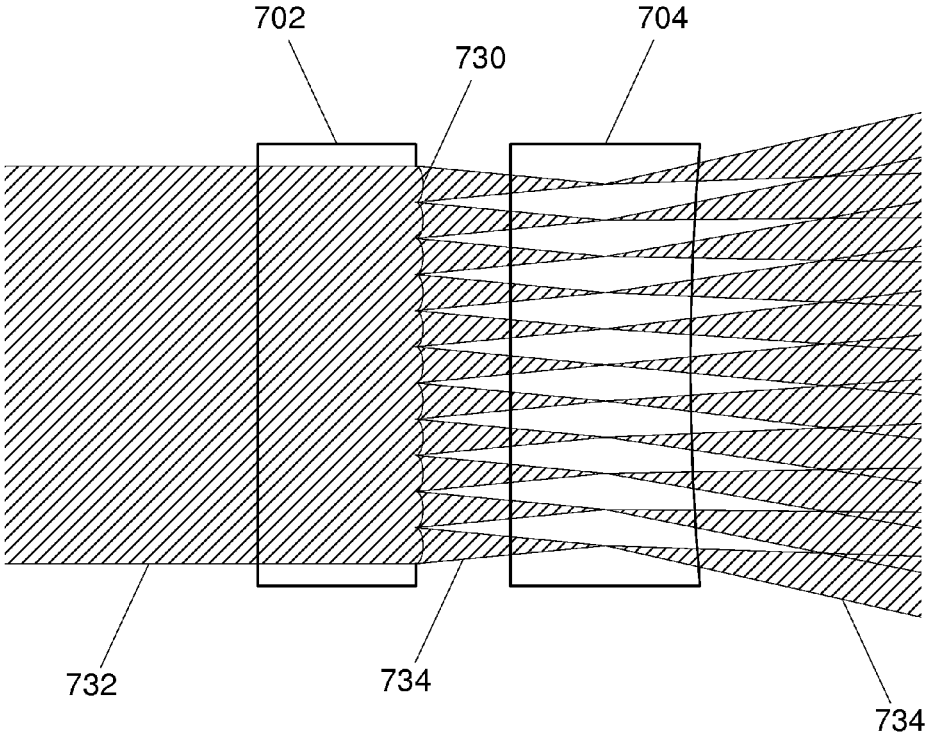

Fig. 20

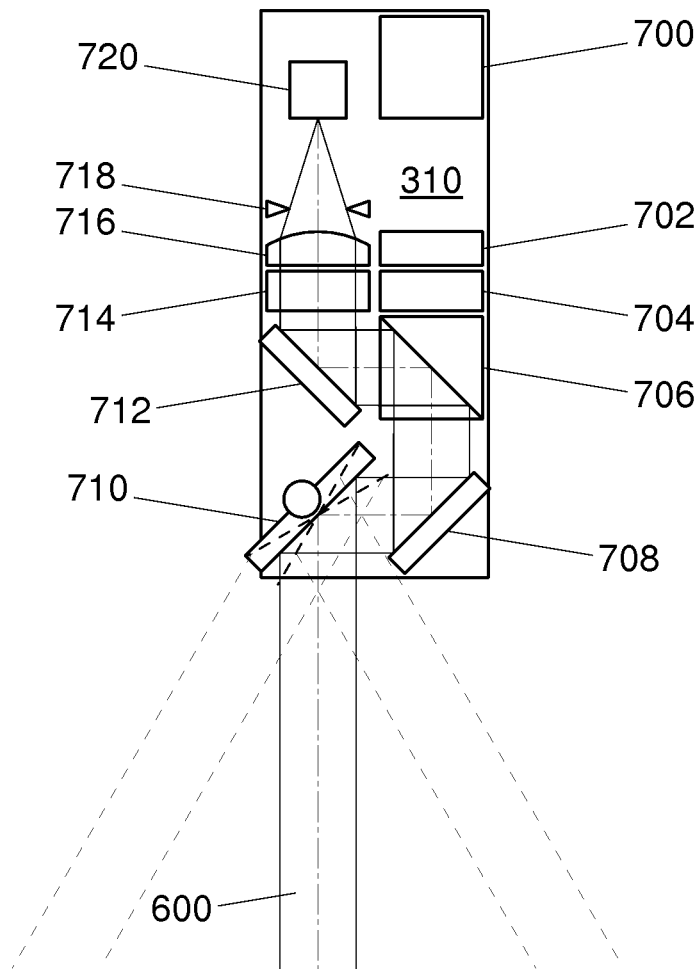

Fig. 21A

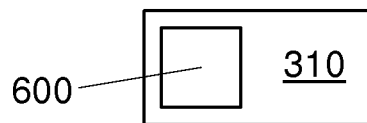

Fig. 21B

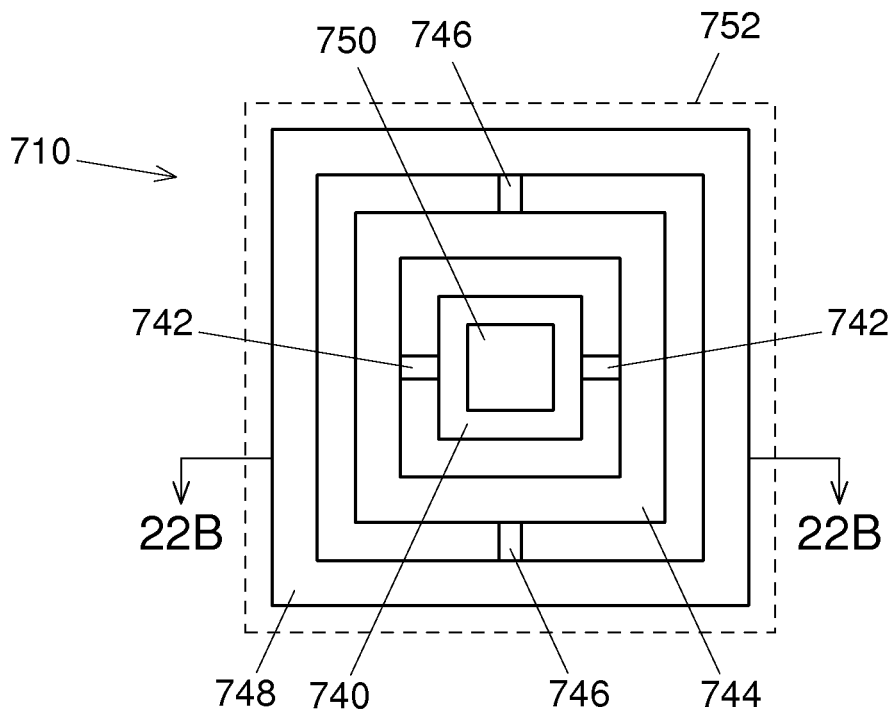

Fig. 22A

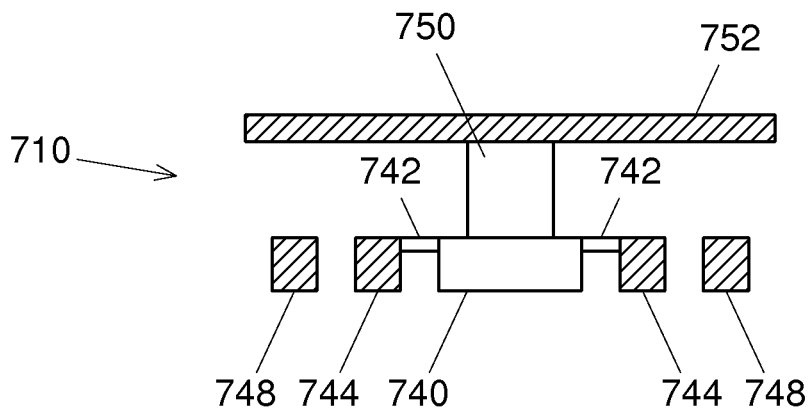

Fig. 22B

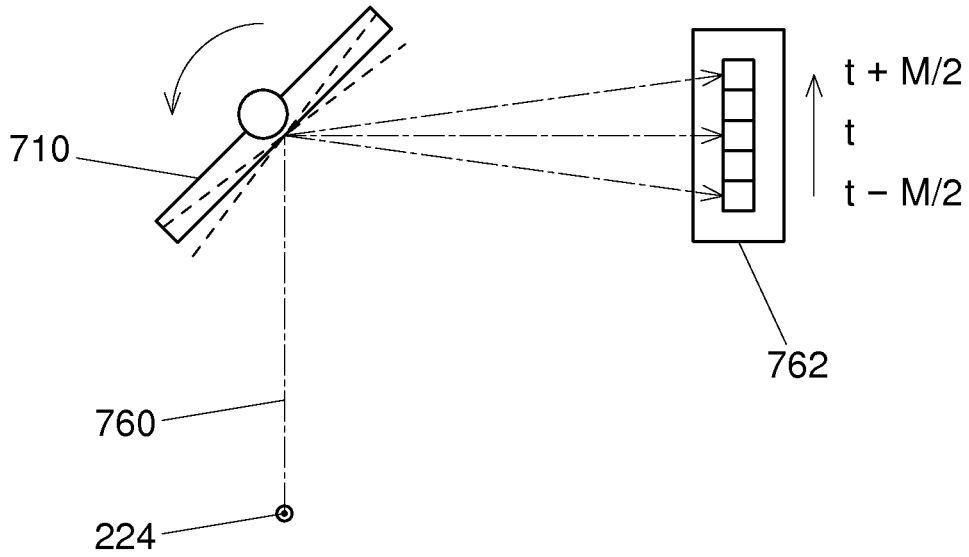

Fig. 23A

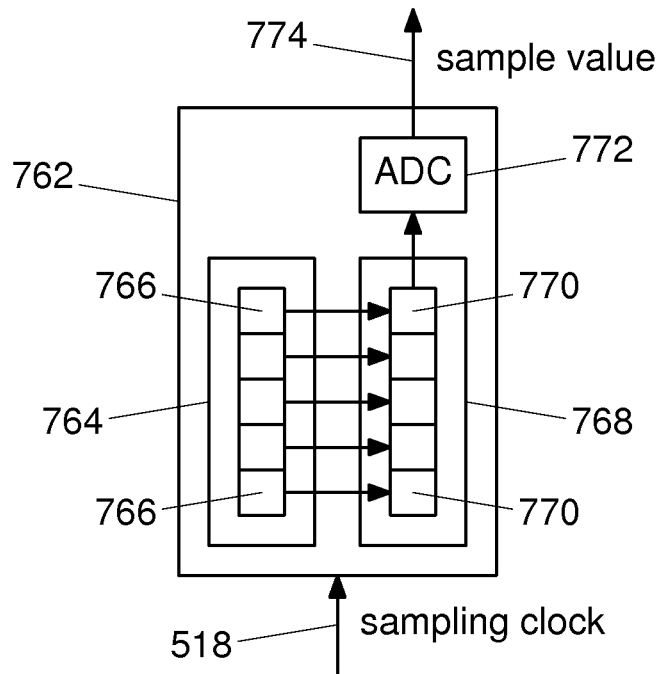

Fig. 23B

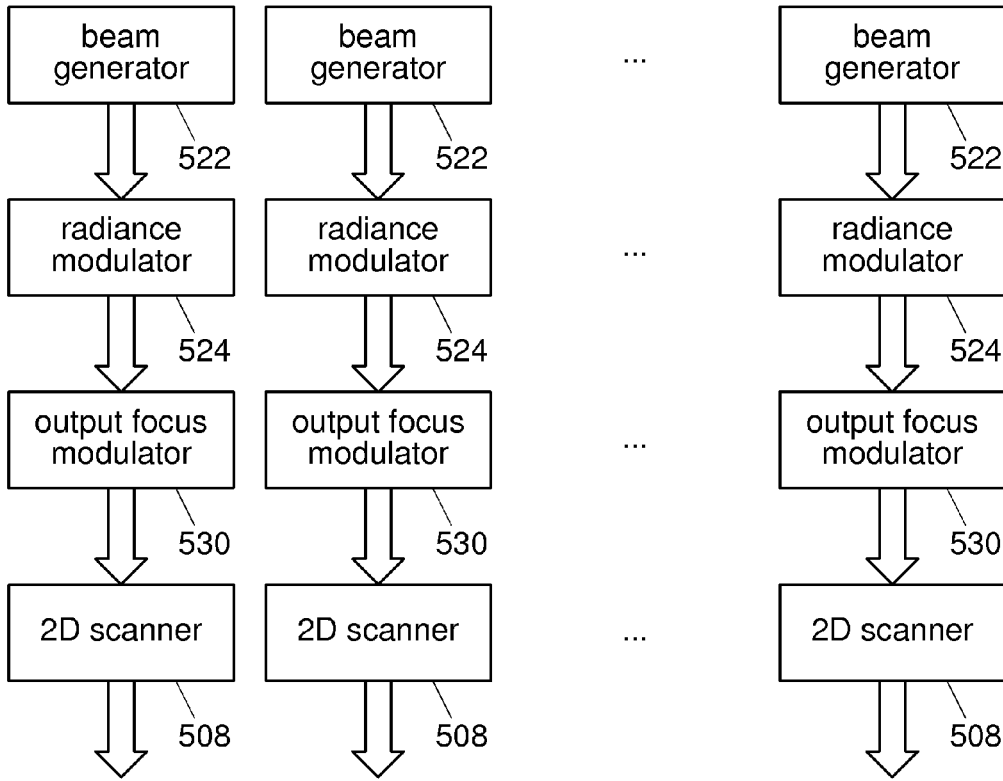

Fig. 24

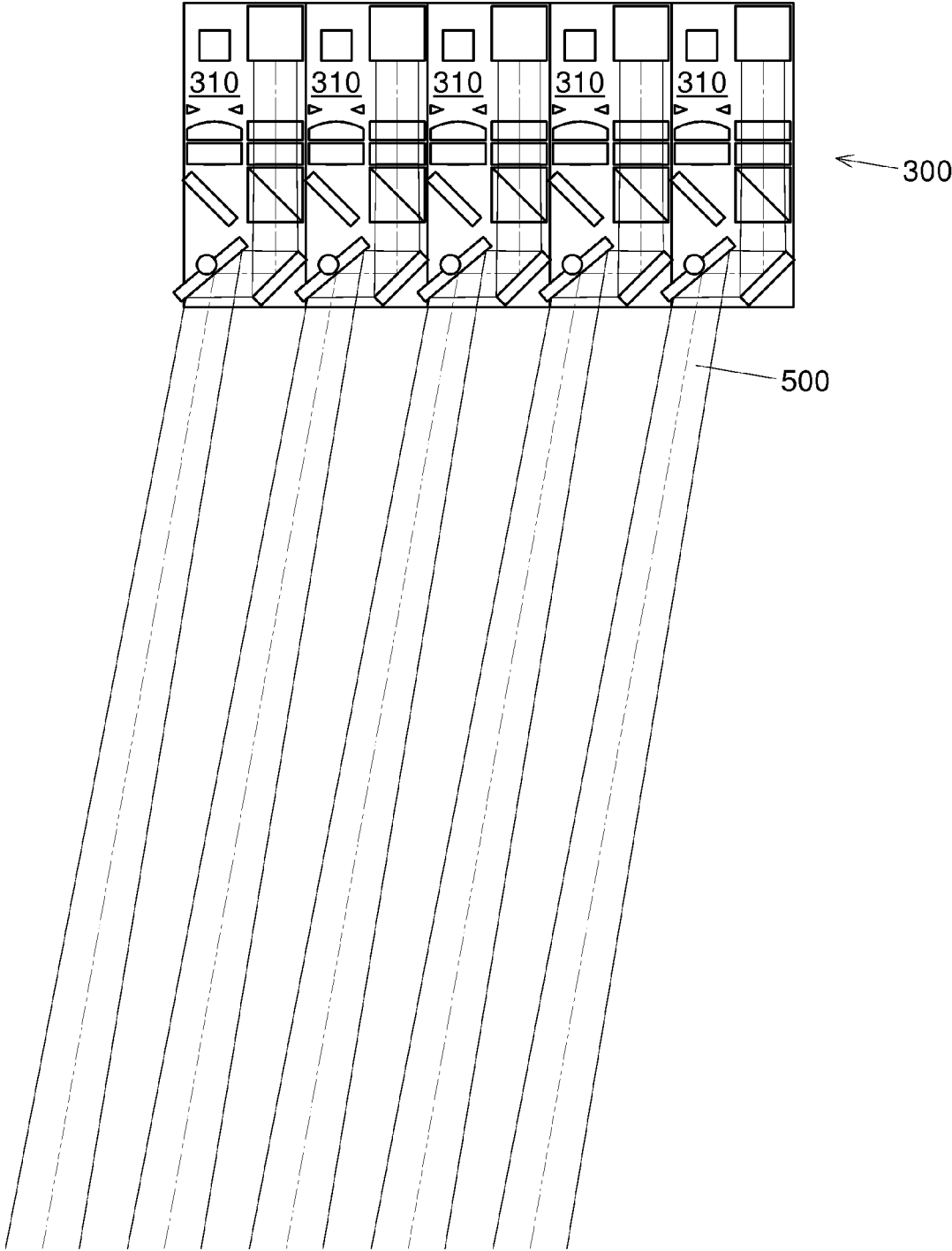

Fig. 25A

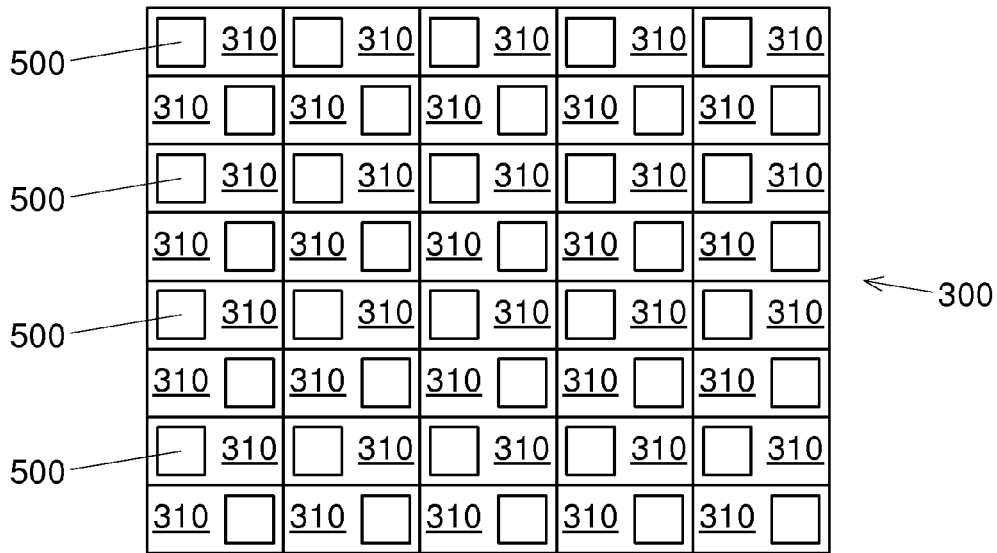

Fig. 25B

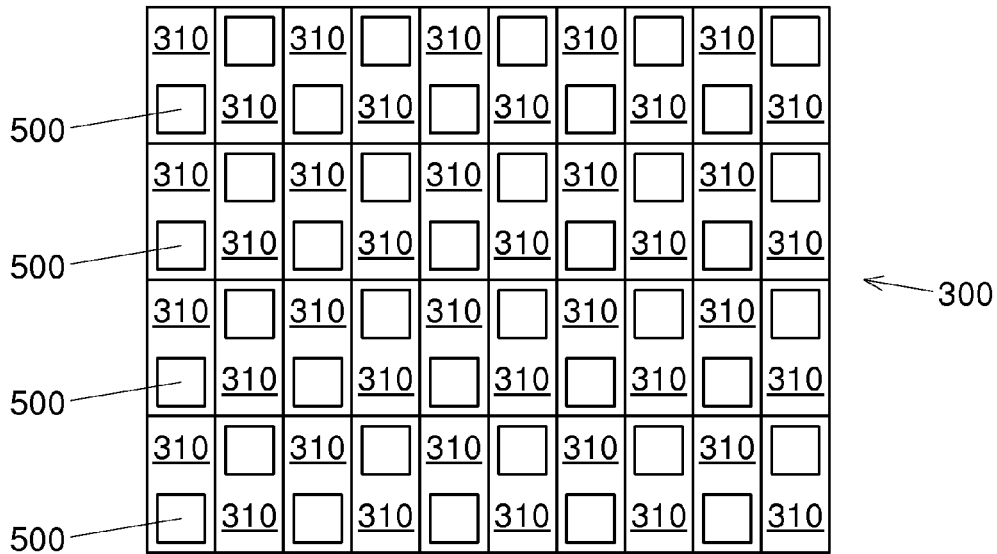

Fig. 25C

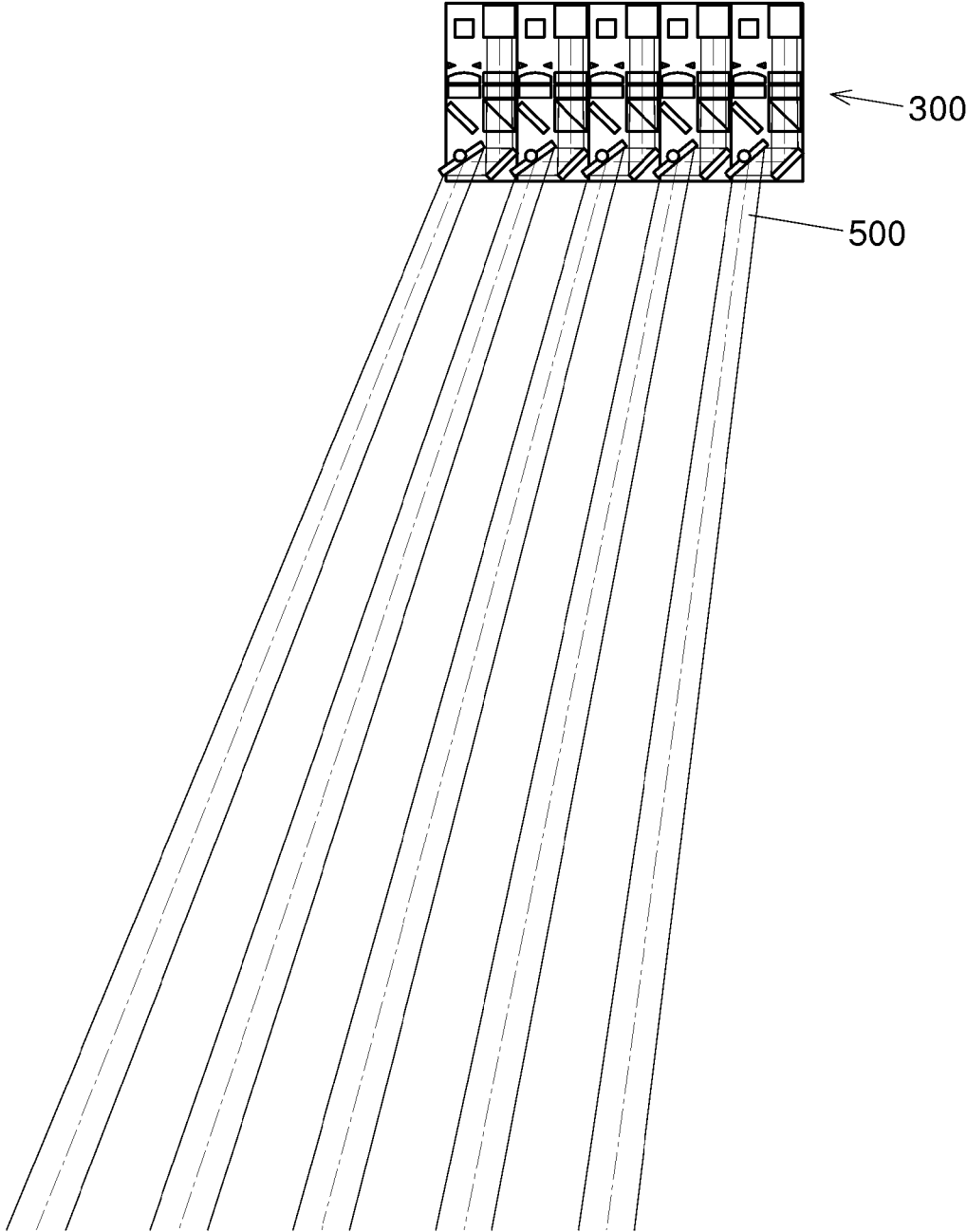

Fig. 26

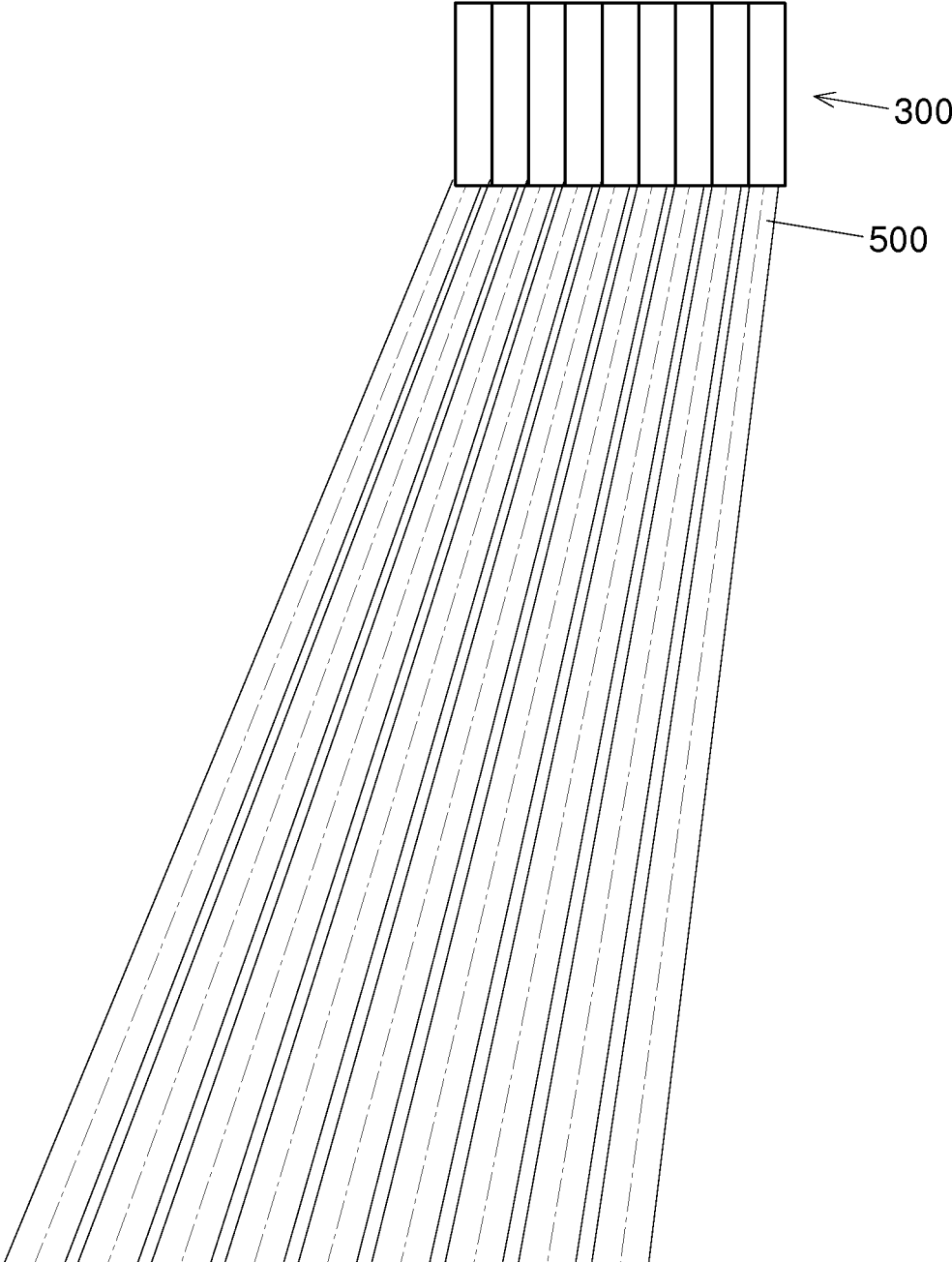

Fig. 27



Fig. 28

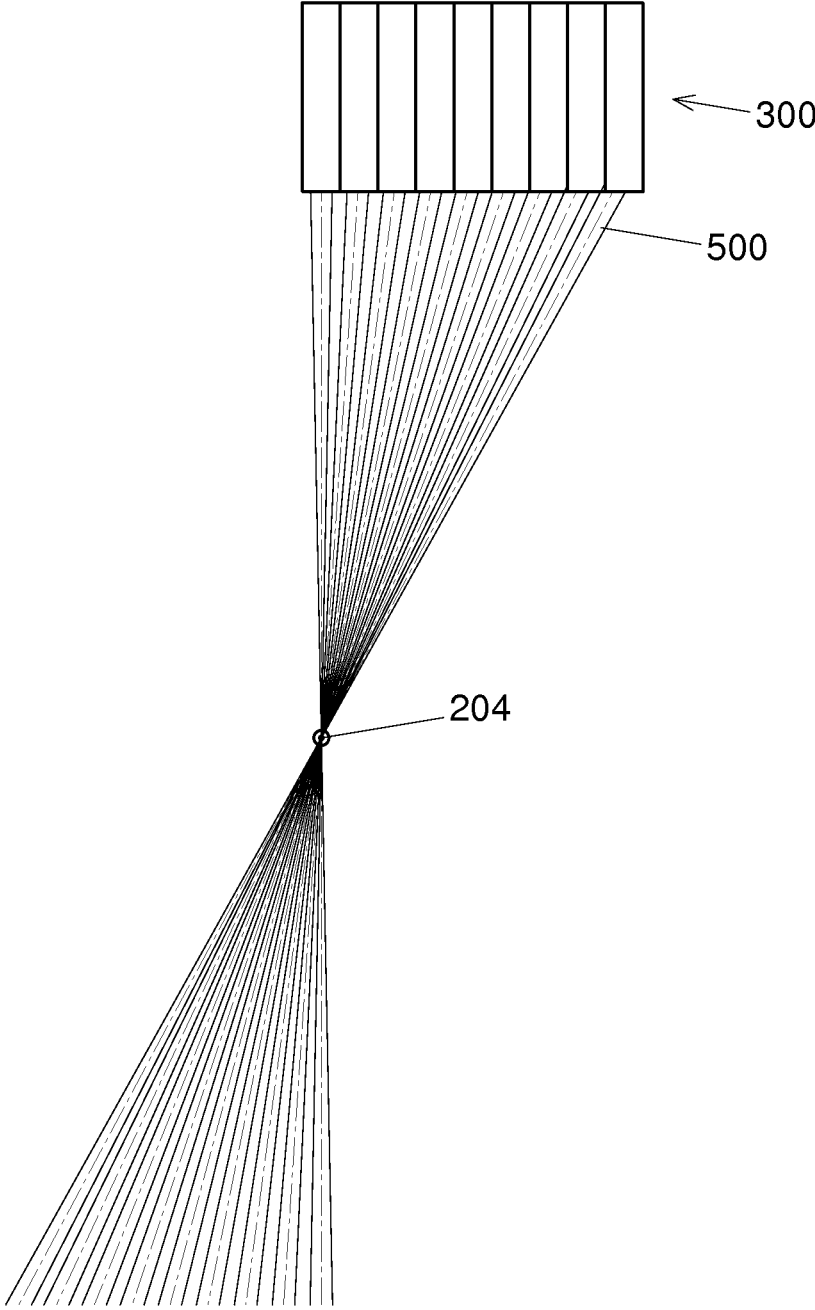

Fig. 29

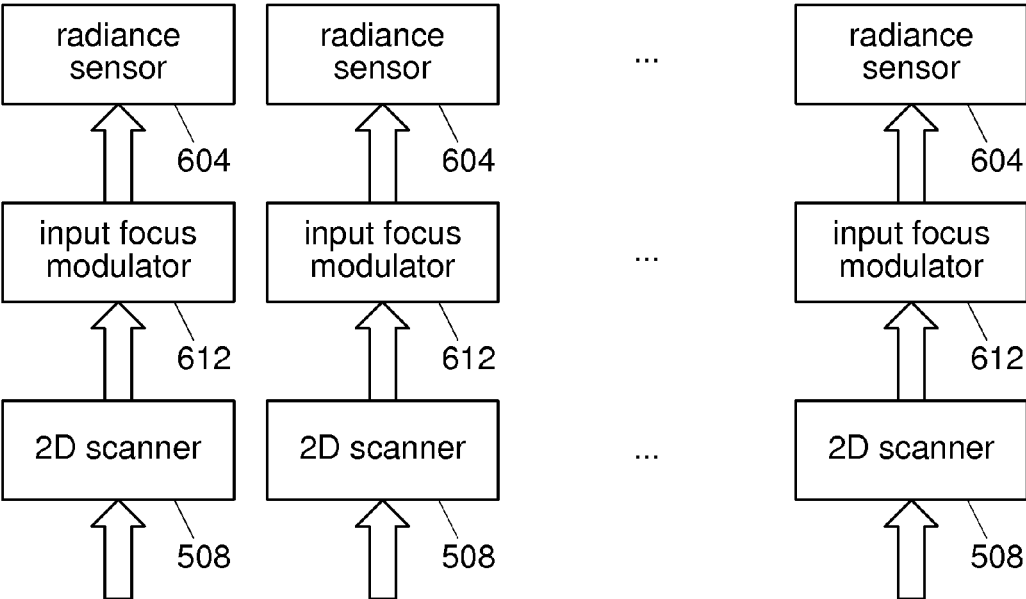

Fig. 30

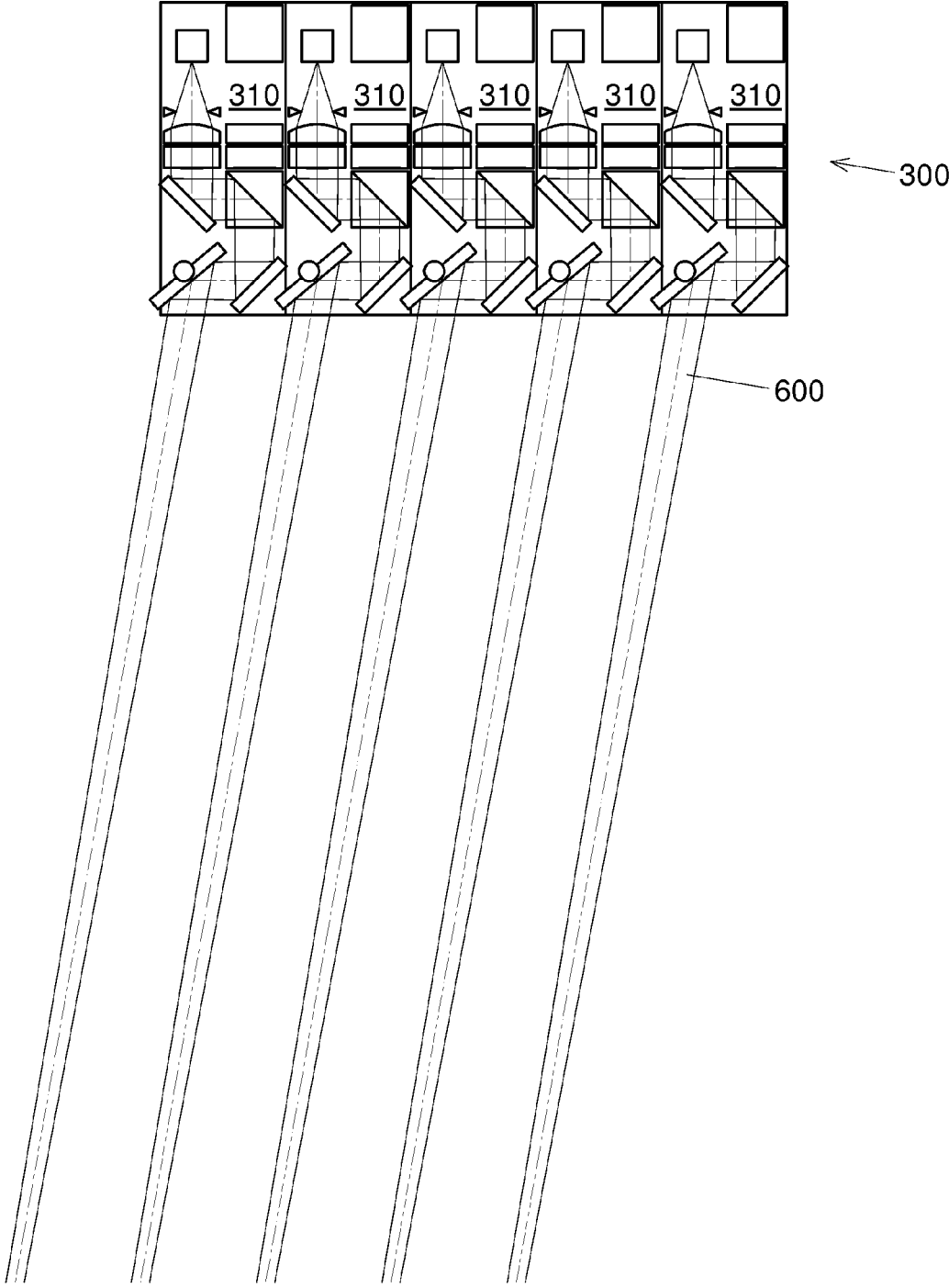

Fig. 31A

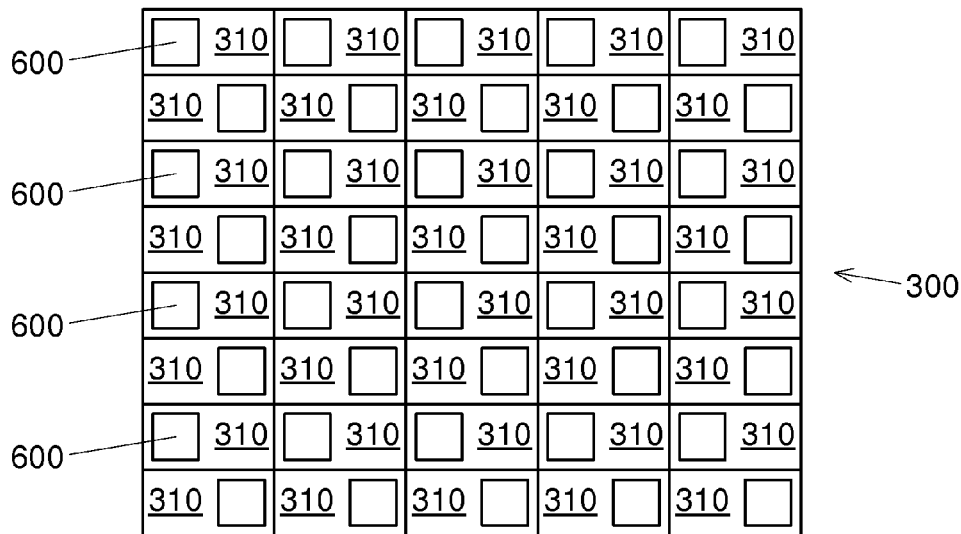

Fig. 31B

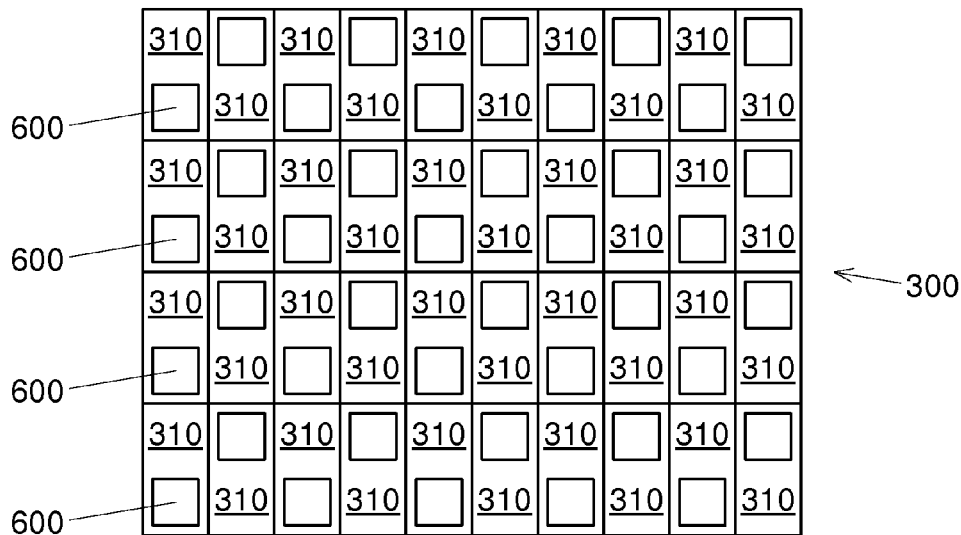

Fig. 31C

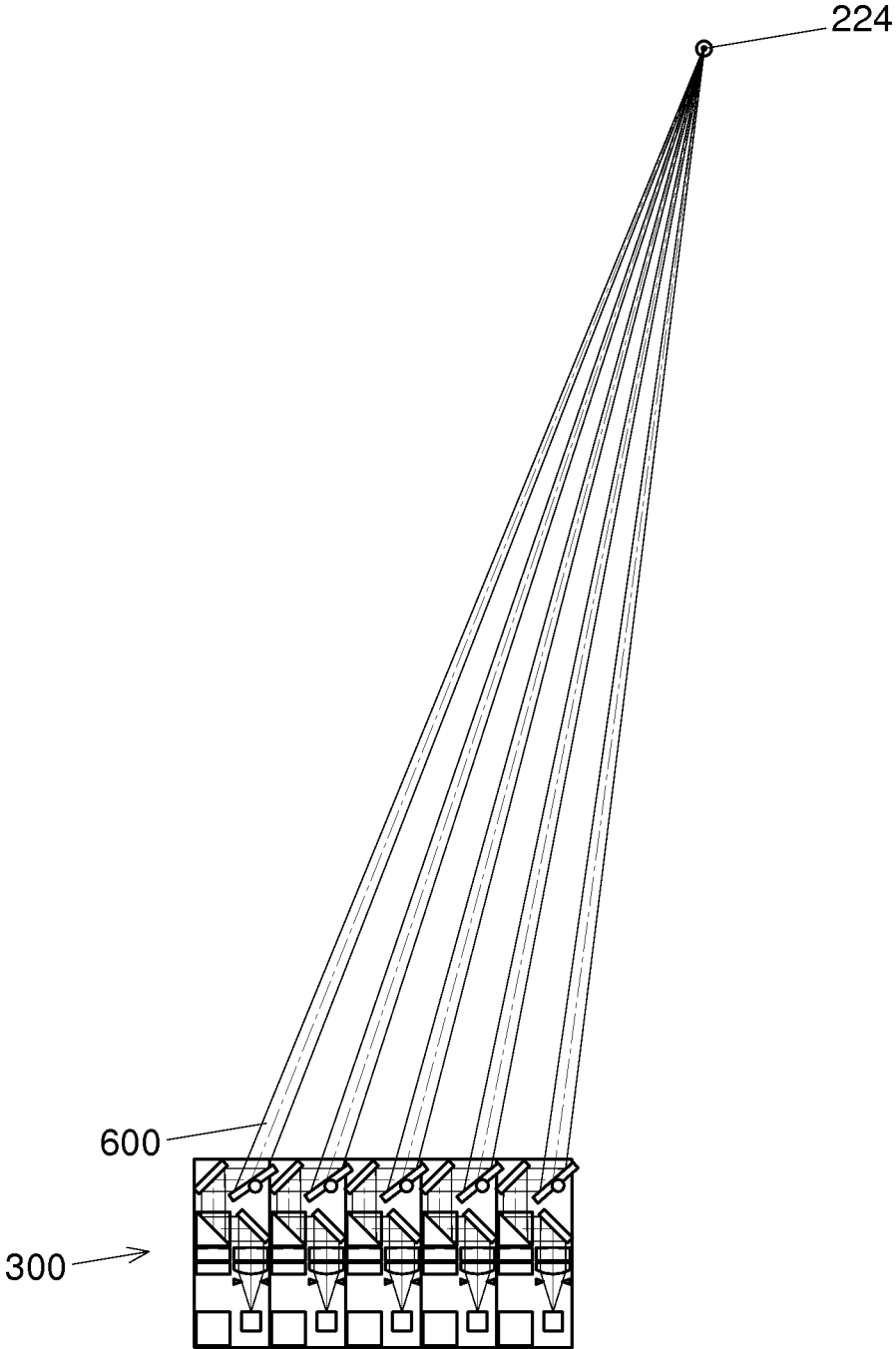

Fig. 32

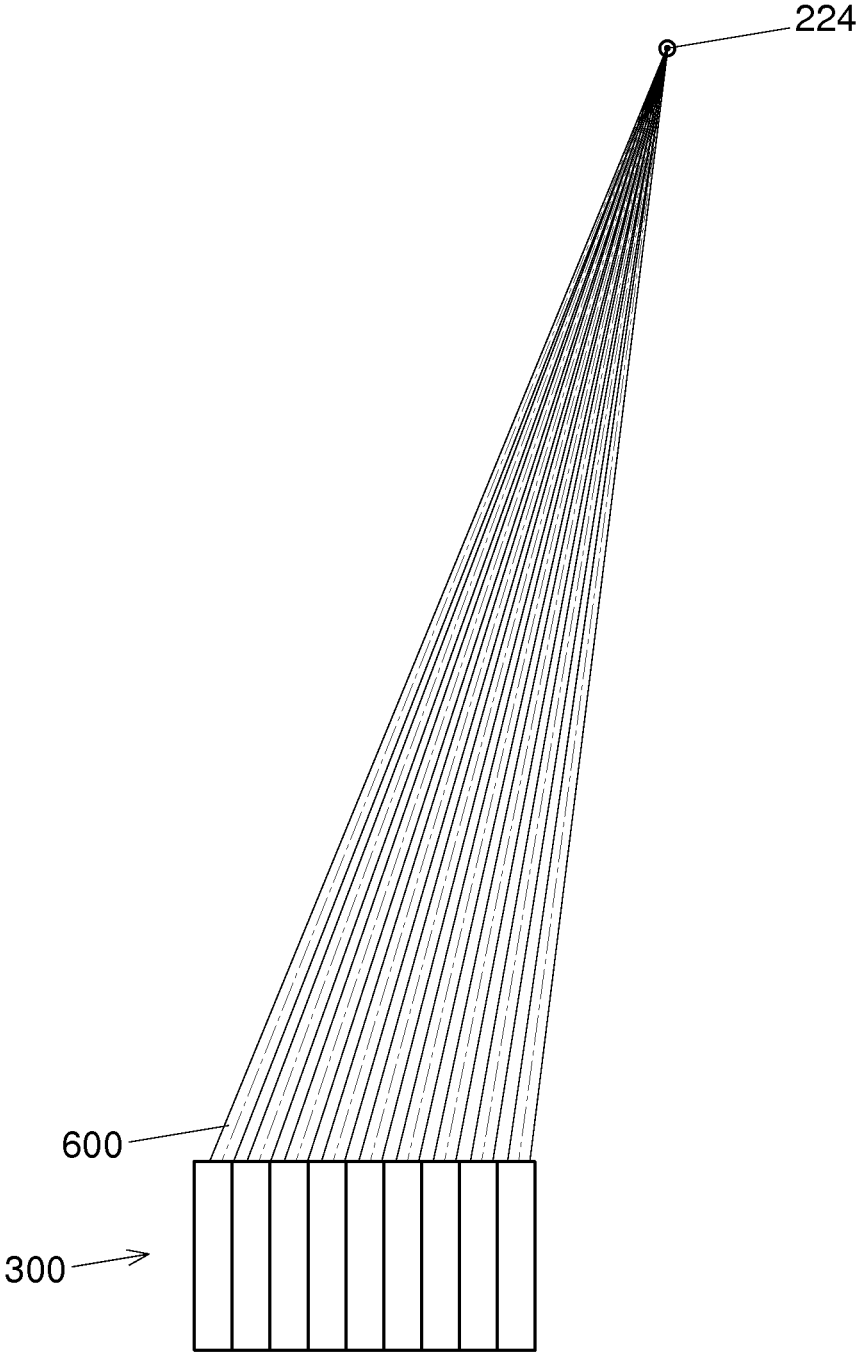

Fig. 33

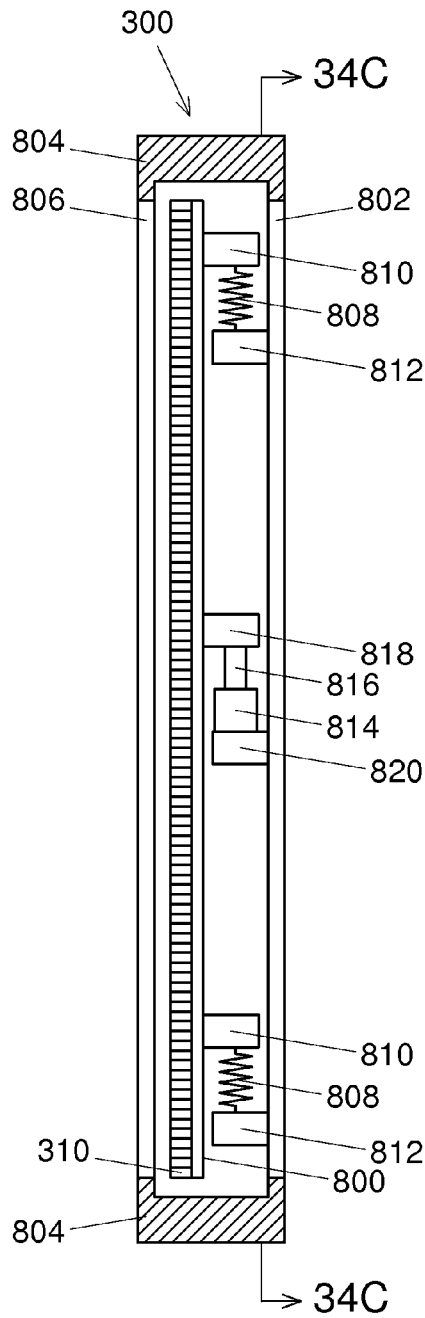

Fig. 34A

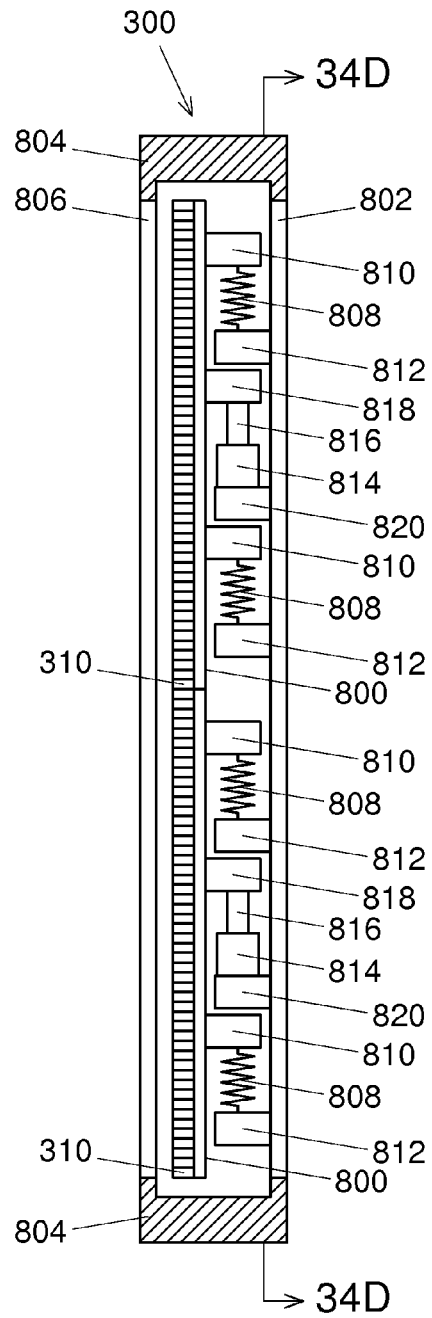

Fig. 34B

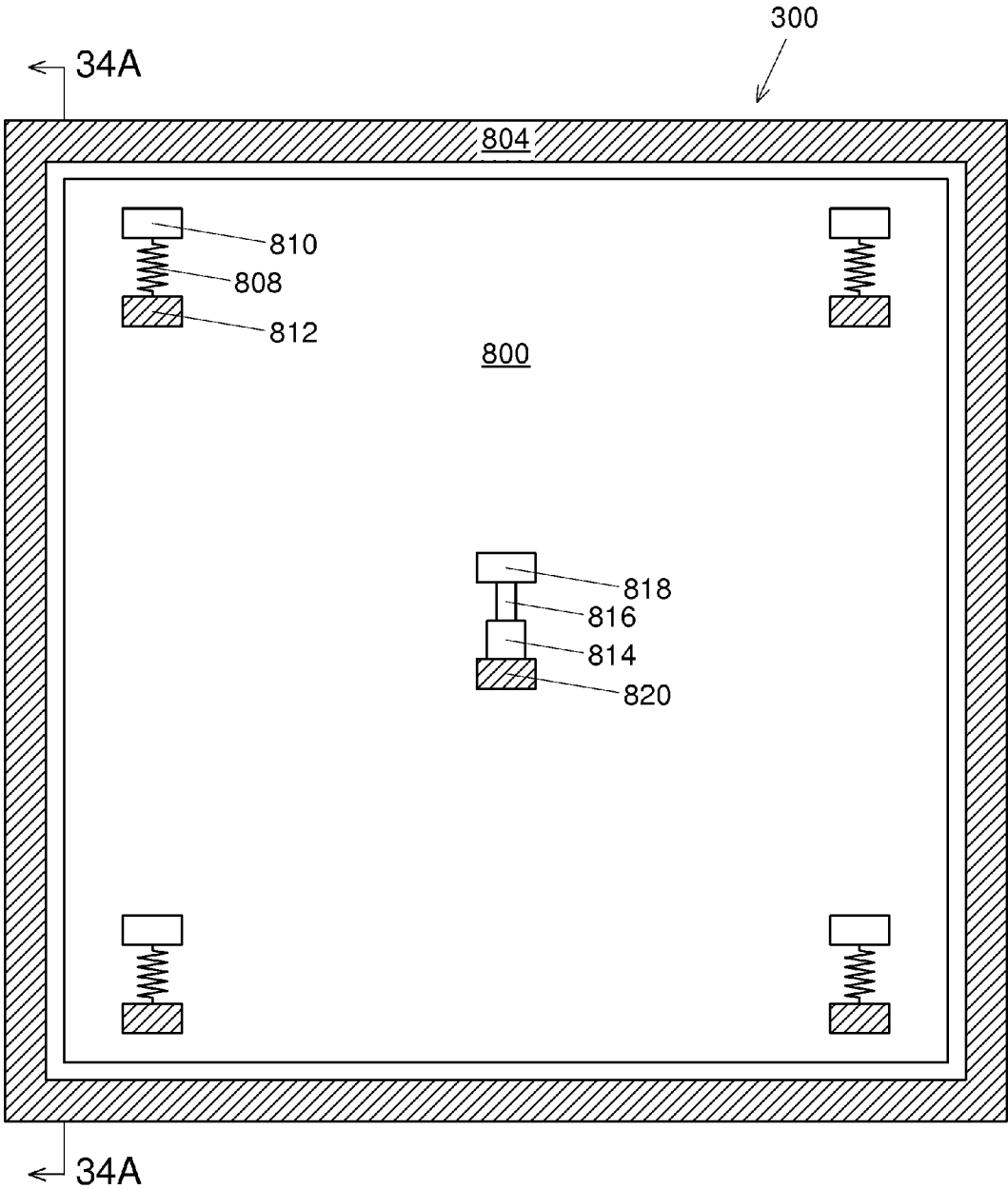

Fig. 34C

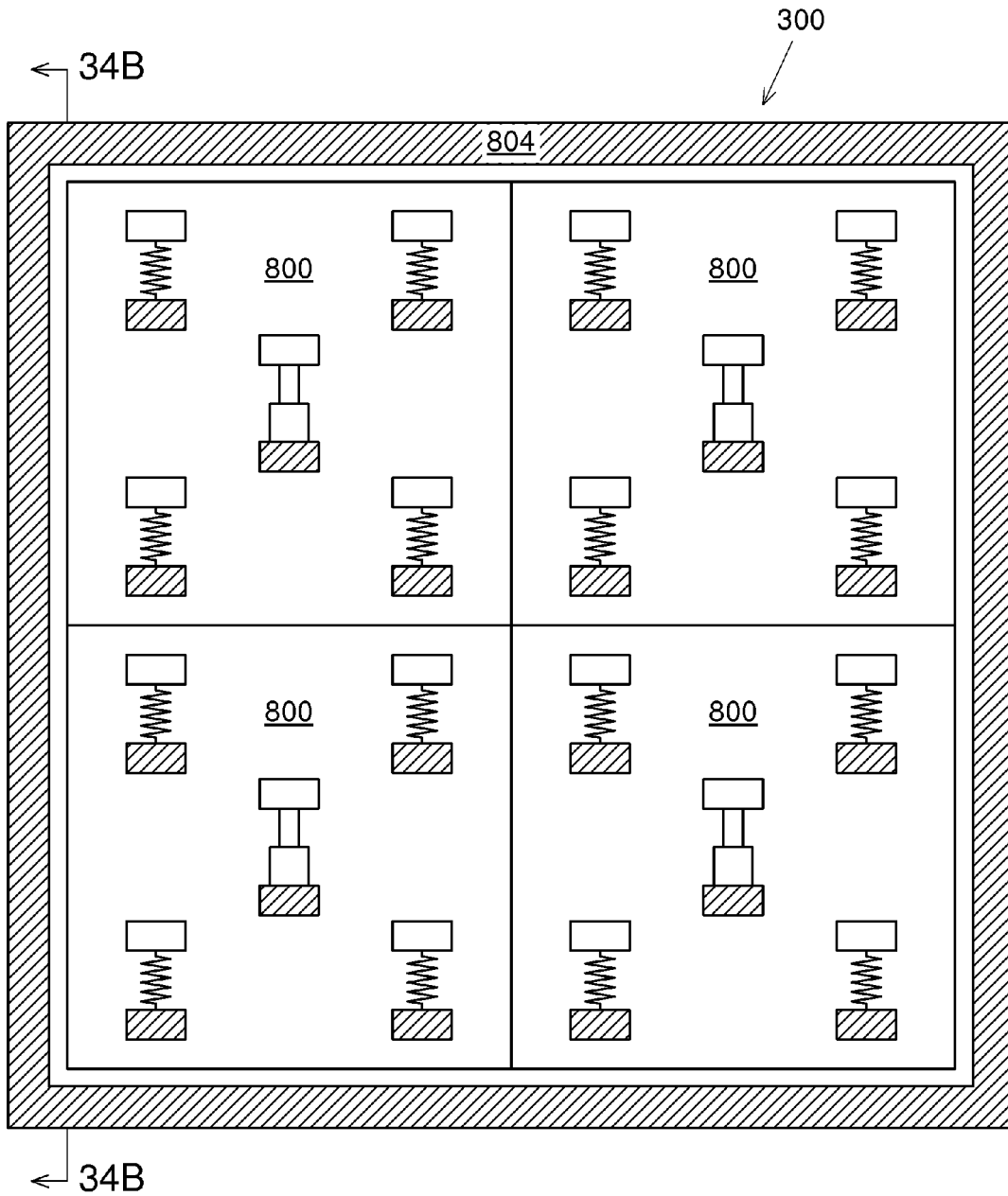

Fig. 34D

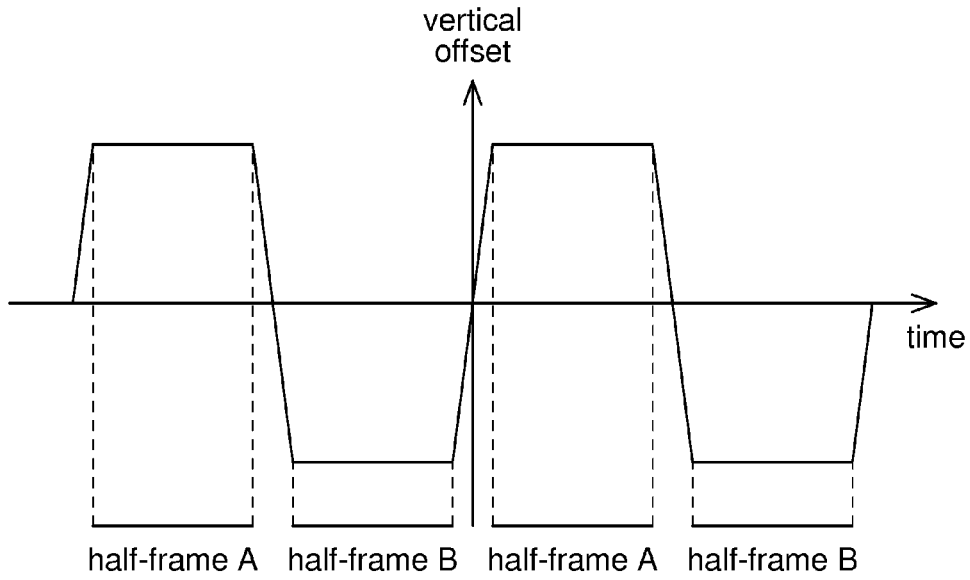

Fig. 35A

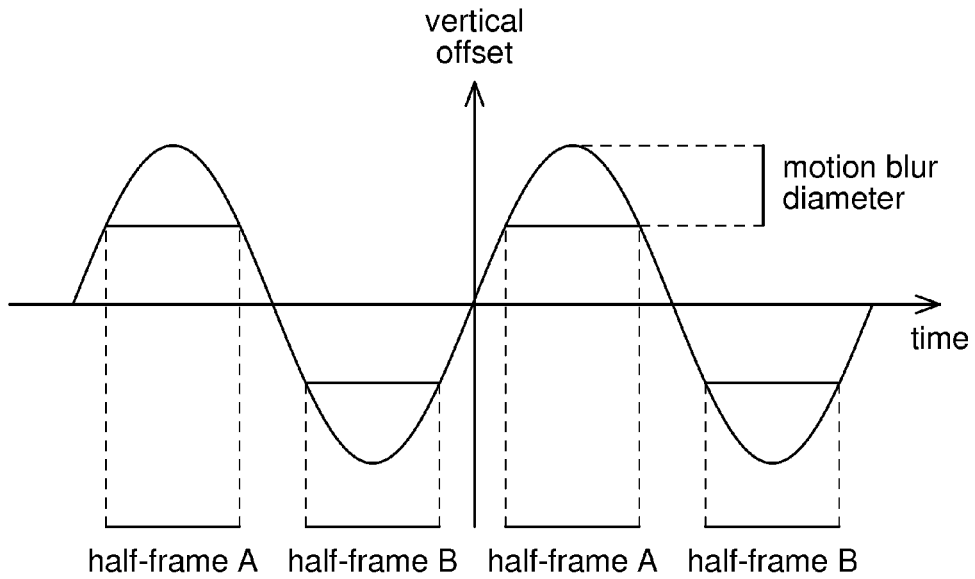

Fig. 35B

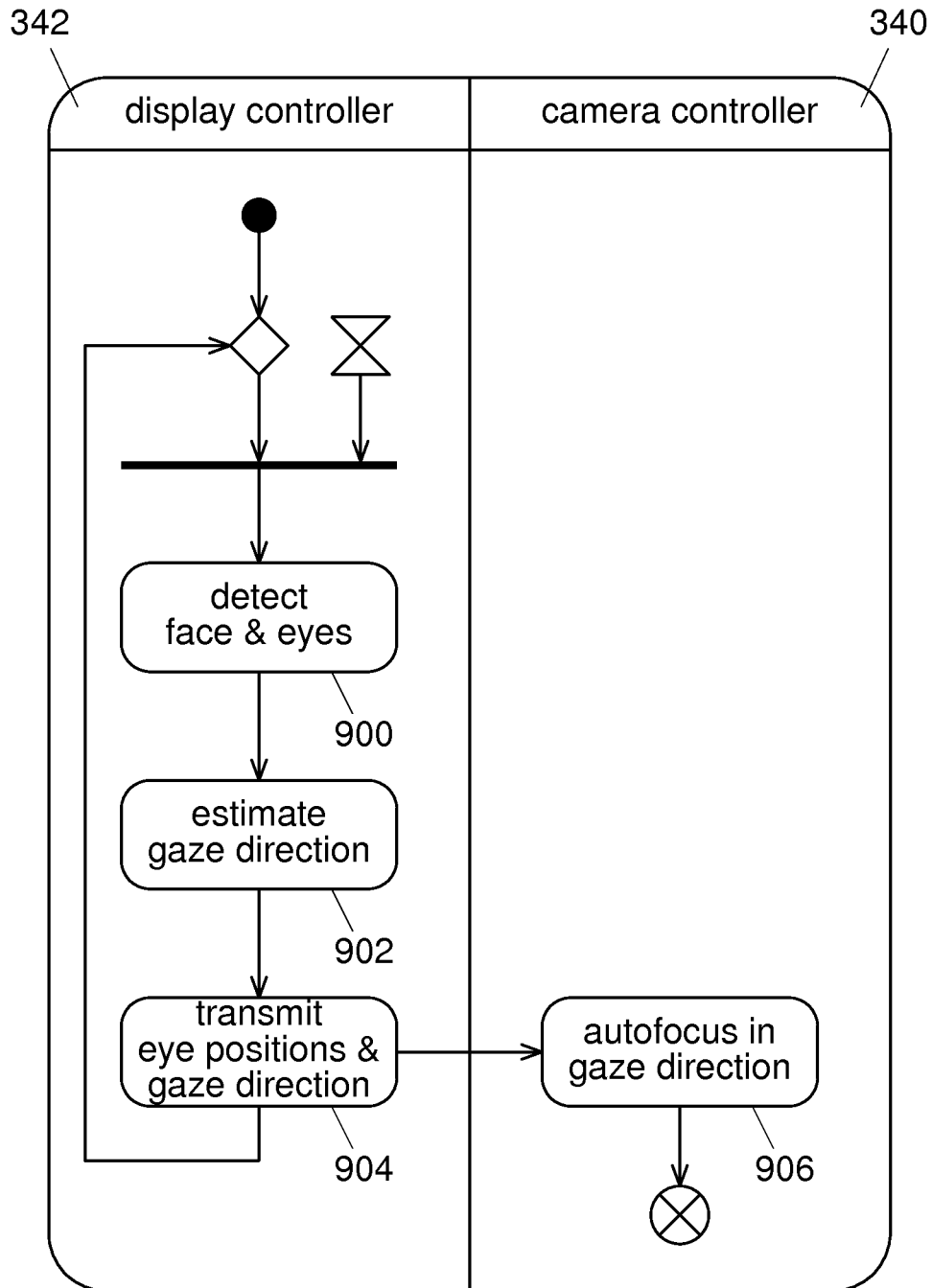

Fig. 36

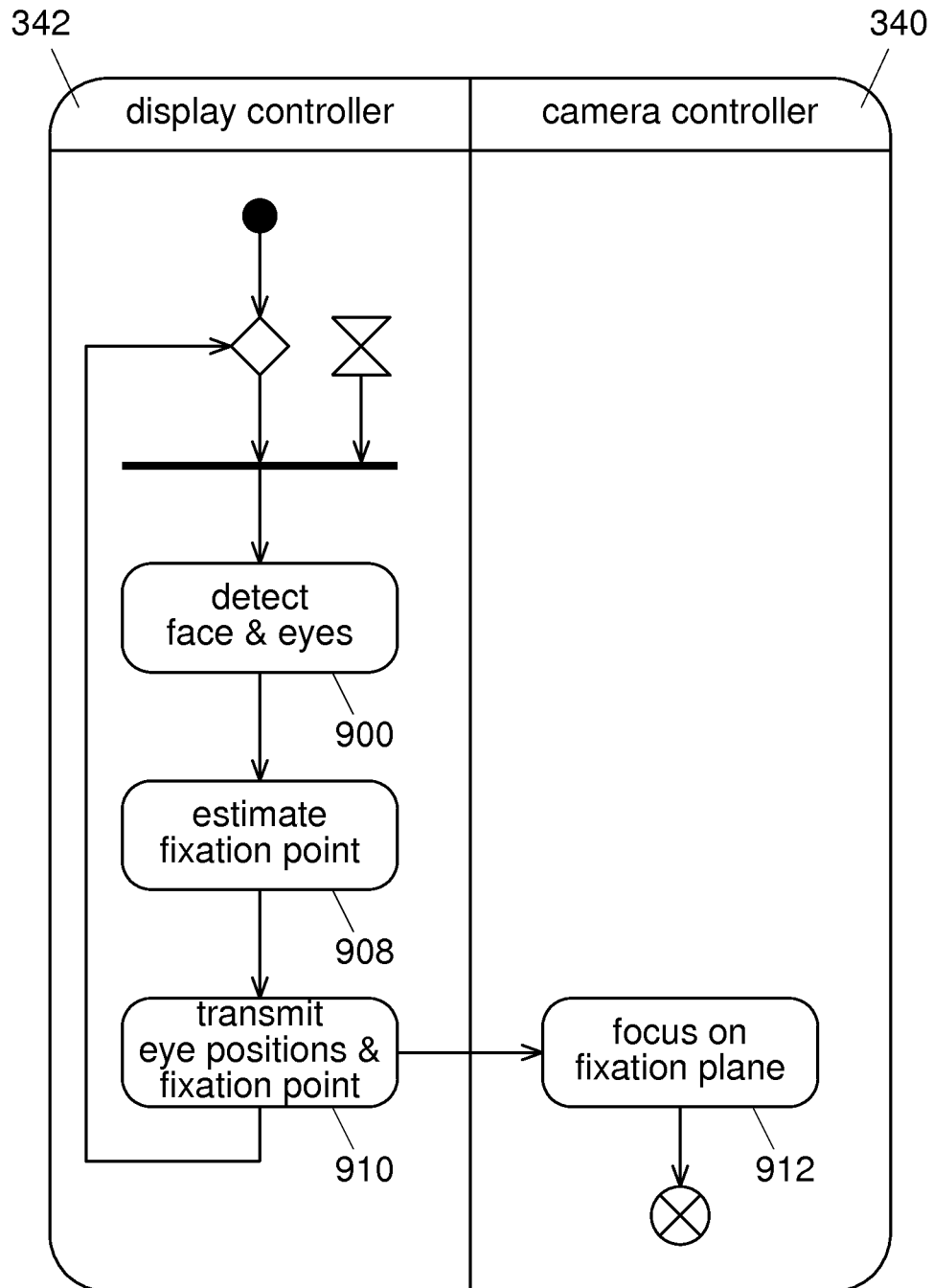

Fig. 37

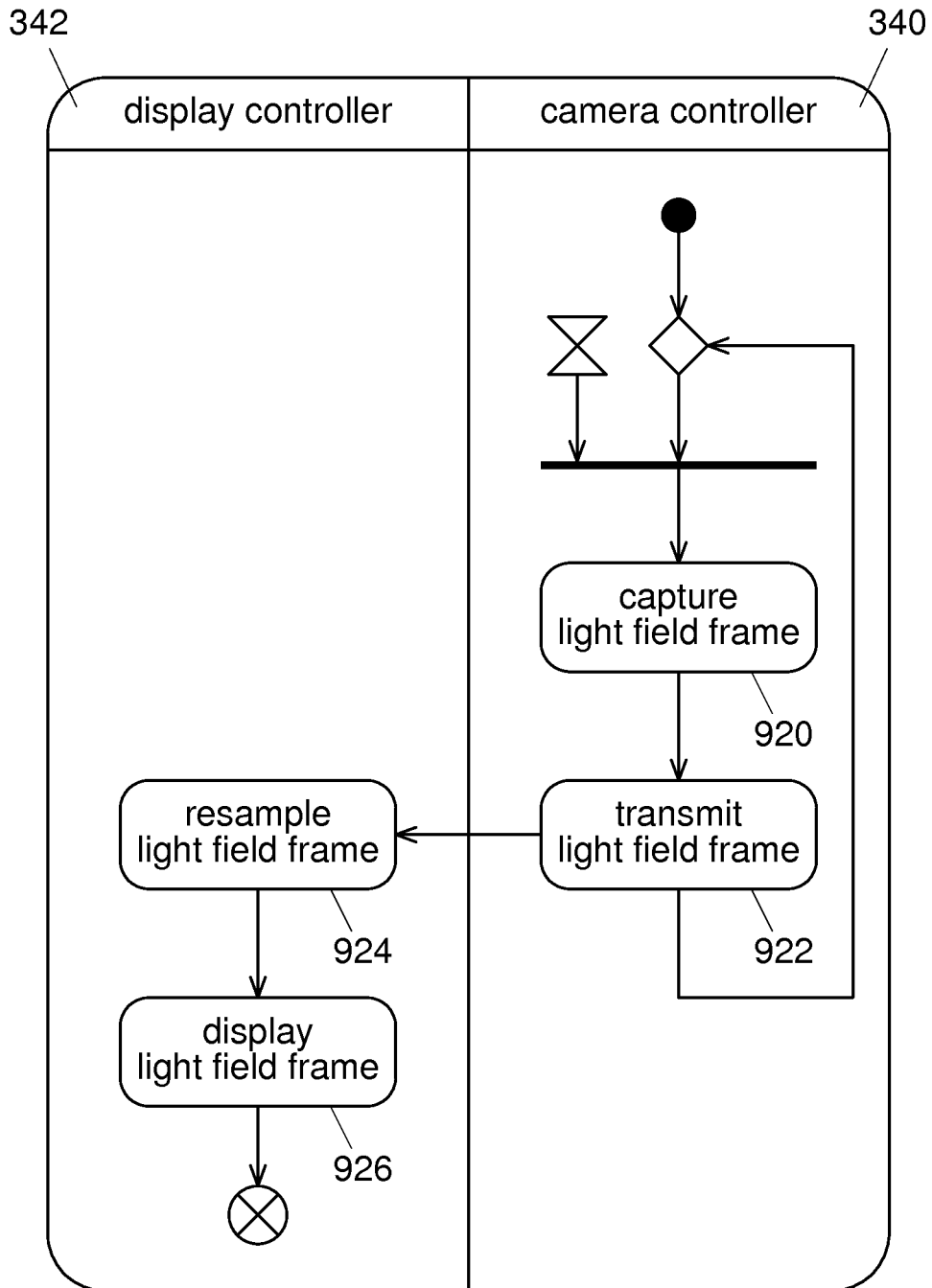

Fig. 38

322

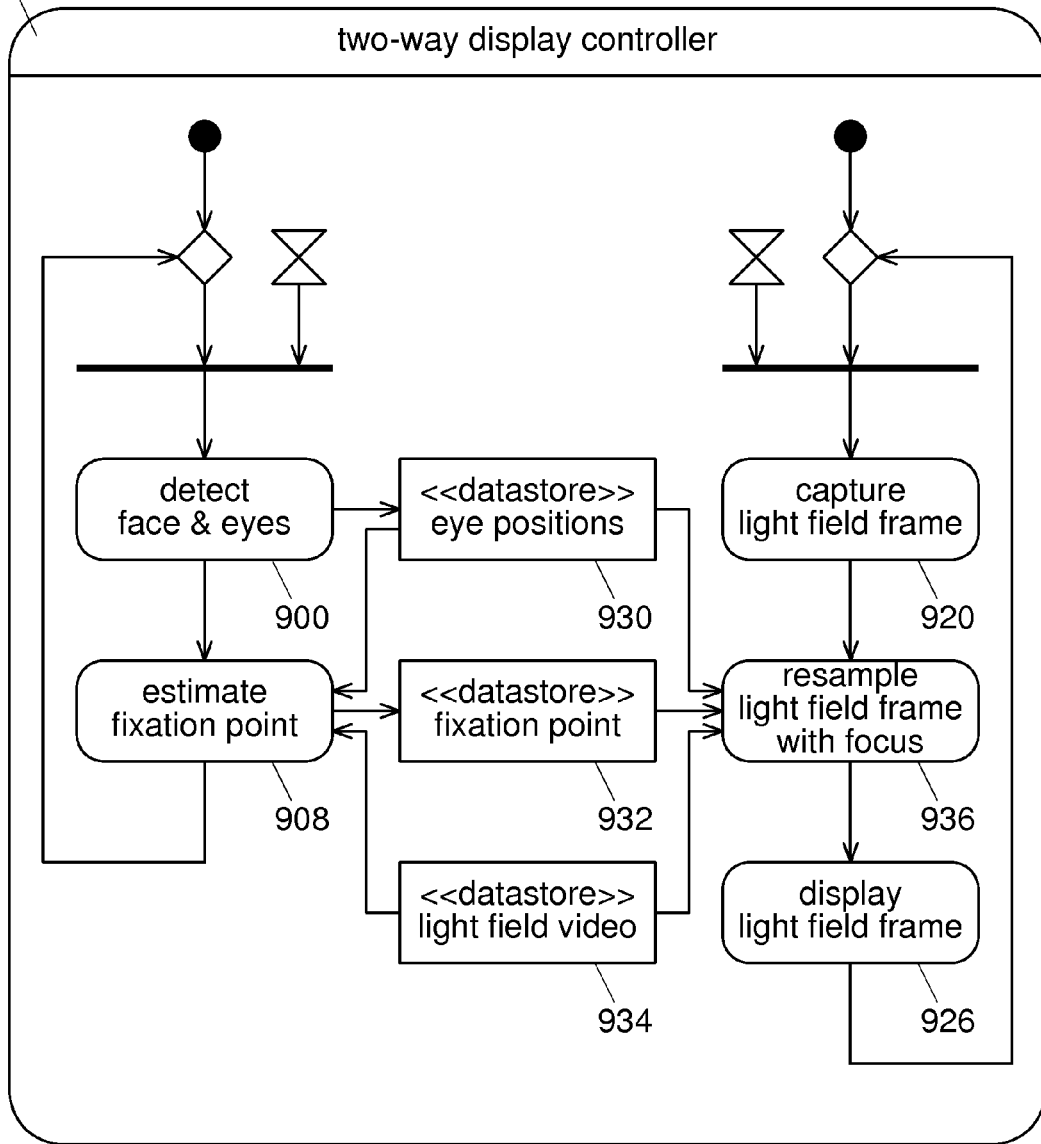

Fig. 39

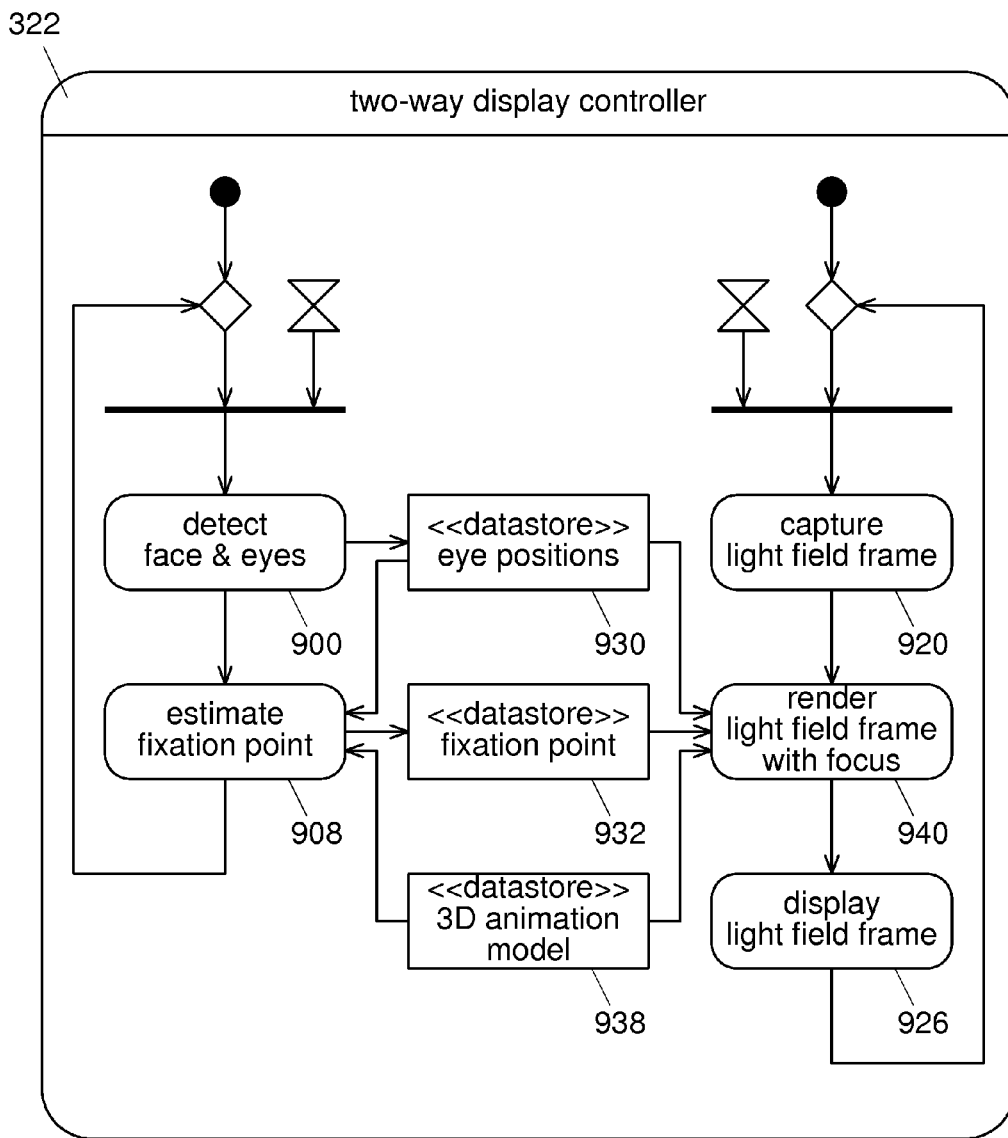

Fig. 40

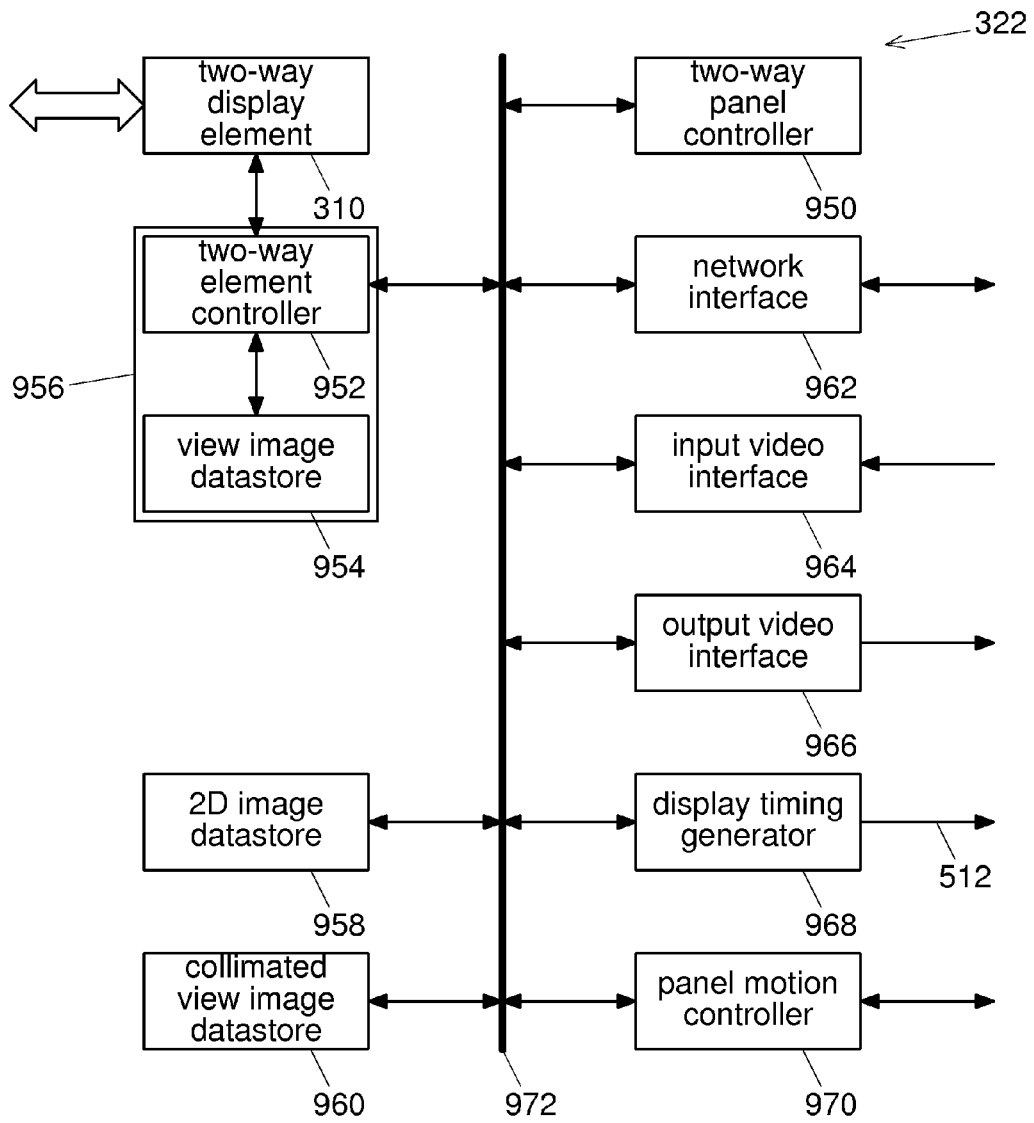

Fig. 41

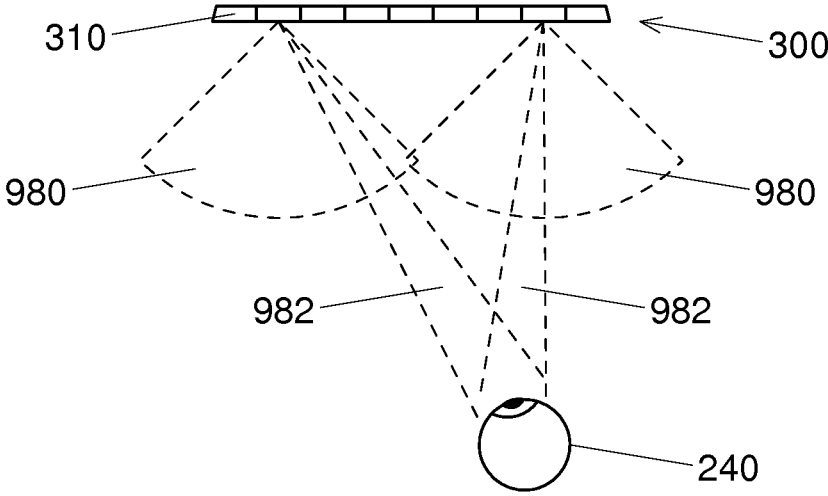

Fig. 42A

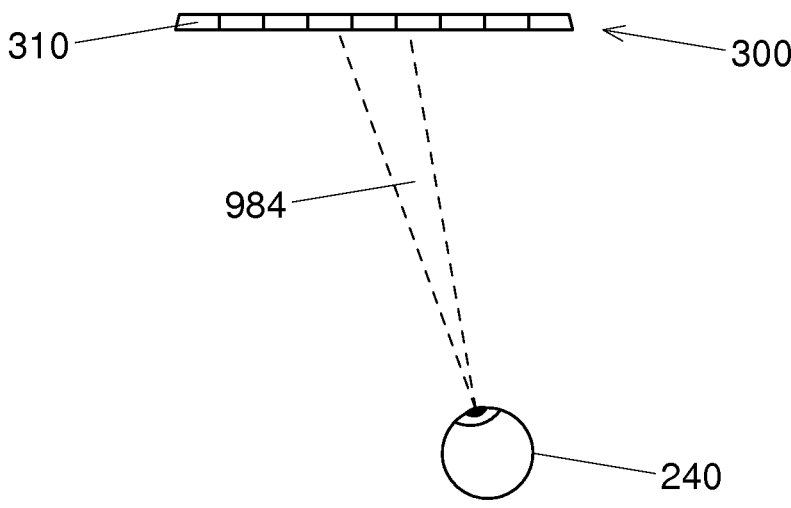

Fig. 42B

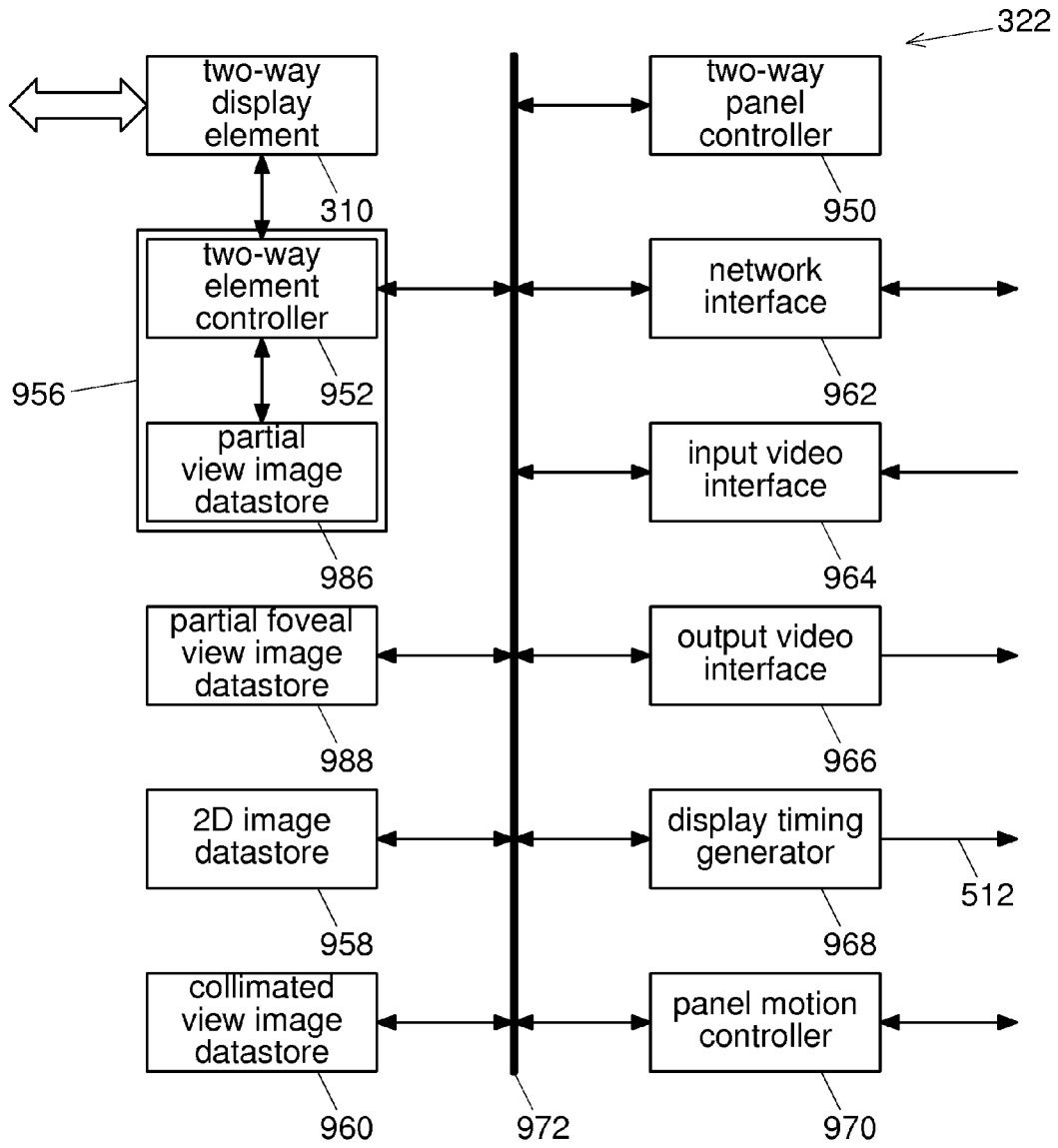

Fig. 43

LIGHT FIELD DISPLAY WITH MEMS SCANNERS

CROSS-REFERENCE TO RELATED APPLICATIONS

[0001] This is a continuation of application Ser. No. 13/567,010, filed Aug. 4, 2012, the contents of which are incorporated herein by reference.

FIELD OF THE INVENTION

[0002] The present invention relates to high-fidelity light field displays, cameras, and two-way displays.

BACKGROUND OF THE INVENTION

[0003] A 7D light field (or plenoptic function [Adelson91]) defines the spectral radiance of every ray passing through every point in a volume of space over time, and therefore contains every possible view within that volume. A 6D light field defines the spectral radiance of every ray passing through a given surface over time, i.e. it represents a slice through a 7D light field.

[0004] Typically, only rays passing through the surface in one direction are of interest, e.g. rays emitted by a volume bounded by the surface. The 6D light field at the boundary can be used to extrapolate the 7D light field of the surrounding space, and this provides the basis for a light field display. The extrapolation is performed by rays emitted by the display as they propagate through space.

[0005] Although an optical light field is continuous, for practical manipulation it is band-limited and sampled, i.e. at a discrete set of points on the bounding surface and for a discrete set of ray directions.

[0006] The ultimate purpose of a light field display, in the present context, is to reconstruct a continuous optical light field from an arbitrary discrete light field with sufficient fidelity that the display appears indistinguishable from a window onto the original physical scene from which the discrete light field was sampled, i.e. all real-world depth cues are present. A viewer sees a different view from each eye; is able to fixate and focus on objects in the virtual scene at their proper depth; and experiences smooth motion parallax when moving relative to the display.

[0007] The ultimate purpose of a light field camera, in the present context, is to capture a discrete light field of an arbitrary physical scene with sufficient fidelity that the discrete light field, when displayed by a high-fidelity light field display, appears indistinguishable from a window onto the original scene.

[0008] Existing glasses-free three-dimensional (3D) displays fall into three broad categories [Benzie07, Connor11]: autostereoscopic, volumetric, and holographic. An autostereoscopic display provides the viewer (or multiple viewers) with a stereo pair of 2D images of the scene, either within a single viewing zone or within multiple viewing zones across the viewing field, and may utilise head tracking to align the viewing zone with the viewer. A volumetric display generates a real 3D image of the scene within the volume of the display, either by rapidly sweeping a 0D, 1D or 2D array of light emitters through the volume, or by directly emitting light from a semi-transparent voxel array. A holographic display uses diffraction to recreate the wavefronts of light emitted by the original scene [Yaras10].

[0009] Volumetric and holographic displays both reconstruct nominally correct optical light fields, i.e. they generate wide-field wavefronts with correct centers of curvature. However, volumetric displays suffer from two major drawbacks: the reconstructed scene is confined to the volume of the display, and the entire scene is semi-transparent (making it unsuitable for display applications that demand realism). Practical holographic displays suffer from limited size and resolution, and typically only support horizontal parallax in current implementations [Schwerdtner06, Yaras10, Barabas11].

[0010] Typical multiview autostereoscopic displays provide a limited number of views, so don't support motion parallax. So-called 'holoform' autostereoscopic displays [Balogh06, Benzie07, Urey11] provide a larger number of views (e.g. 10-50), so provide a semblance of (typically horizontal-only) motion parallax. However, they do not reconstruct even nominally correct optical light fields.

SUMMARY OF THE INVENTION

[0011] In a first aspect, the present invention provides a light field display device comprising an array of light field display elements populating a display surface, each display element comprising: a beam generator for generating an output beam of light; a radiance modulator for modulating the radiance of the beam over time; a focus modulator for modulating the focus of the beam over time; and a scanner for scanning the beam across a two-dimensional angular field.

[0012] Persistence of vision, combined with a sufficiently rapid scan rate, allows a viewer to perceive the scanned beams as a continuous optical light field.

[0013] The appropriate focus of each beam ensures that the viewer perceives smooth parallax both between and within beams, and experiences consistent vergence and accommodation cues.

[0014] The light field display device optionally further comprises at least one actuator for oscillating the display surface between at least two positions. The oscillation may be resonant.

[0015] Oscillating the display surface allows incomplete coverage of the display surface by the exit pupils of the display elements to be improved.

[0016] The scanner is optionally configured to scan an input beam across the two-dimensional angular field, and each display element optionally further comprises: an input focus modulator for modulating the focus of the input beam; a radiance sensor for sensing the radiance of the input beam; and a radiance sampler for sampling the radiance of the input beam.

[0017] This allows the light field display to also function as a light field camera.

[0018] In a second aspect, the present invention provides a method for displaying a light field, the method comprising, for each of a set of positions on a display surface, the steps of: generating an output beam of light; modulating the radiance of the beam over time; modulating the focus of the beam over time; and scanning the beam across a two-dimensional angular field.

[0019] The radiance of the beam may be modulated in accordance with to a specified radiance value corresponding to the position on the display surface and the instantaneous direction of the scanned beam within the angular field.

[0020] The specified radiance value may be retrieved from a discrete representation of the desired output light field. The discrete light field may have been received from a light field camera device.

[0021] The focus of the beam may be modulated in accordance with a specified depth value corresponding to the position on the display surface and the instantaneous direction of the scanned beam within the angular field.

[0022] The specified depth may be a scene depth or a fixation depth of a viewer of the surface.

[0023] The method may include tracking the face, eyes and gaze of the viewer to determine a relevant scene depth or the viewer's fixation depth.

[0024] The method optionally further comprises oscillating the display surface between at least two positions.

[0025] The scanning step optionally further comprises scanning an input beam across the two-dimensional angular field, and the method optionally further comprises the steps of: modulating the focus of the input beam over time; sensing the radiance of the input beam over time; and sampling the radiance of the input beam at discrete times.

[0026] The sampled radiance may be stored in a discrete light field. The discrete light field may be transmitted to a light field display device for display.

DRAWINGS

Figures

[0027] FIG. 1A shows a representative ray of a continuous 6D light field, traversing the boundary of a volume of interest.

[0028] FIG. 1B shows a class diagram for a sampled, i.e. discrete, 6D light field.

[0029] FIG. 2A shows a light sensor array sampling ray direction for a particular ray position.

[0030] FIG. 2B shows an array of lenses sampling ray position at the light field boundary.

[0031] FIG. 3A shows the combined effect of the spatial extent of the light sensor and the aperture of the lens to effect 4D low-pass filtering.

[0032] FIG. 3B shows the sampling beam of FIG. 3A focused at a point in object space using a lens with higher power.

[0033] FIG. 4A shows a light emitter array reconstructing ray direction for a particular ray position.

[0034] FIG. 4B shows an array of lenses reconstructing ray position at the light field boundary.

[0035] FIG. 5A shows the combined effect of the spatial extent of the light emitter and the aperture of the lens to effect 4D low-pass filtering.

[0036] FIG. 5B shows the reconstruction beam of FIG. 5A focused from a virtual object point using a lens with lower power.

[0037] FIG. 6A shows matched sampling (left) and reconstruction (right) beams, corresponding to FIGS. 3A and 5A.

[0038] FIG. 6B shows matched sampling (left) and reconstruction (right) beams focused at/from an object point, corresponding to FIGS. 3B and 5B.

[0039] FIG. 7A shows wavefronts emitted from an ideal light field display.

[0040] FIG. 7B shows wavefronts emitted from a multi-element light field display.

[0041] FIG. 8A shows wavefronts captured by an ideal light field display.

[0042] FIG. 8B shows wavefronts captured by a multi-element light field display.

[0043] FIG. 9A shows the eye of a viewer located in the reconstructed light field of a virtual point source, with the eye focused at the point source.

[0044] FIG. 9B shows the eye focused at a closer point than the virtual point source.

[0045] FIG. 9C shows the light field display of FIGS. 9A and 9B emitting the light field of a point source coinciding with the translated object point of FIG. 9B.

[0046] FIG. 10A shows a viewer gazing at a light field display emitting a light field corresponding to a virtual scene consisting of several objects.

[0047] FIG. 10B shows the location of one of the eyes used to determine a viewing direction through each display element, and thus, for each viewing direction, an intersection point with a scene object.

[0048] FIG. 10C shows the gaze direction of each of the viewer's two eyes used to estimate their fixation point.

[0049] FIG. 10D shows the plane of focus of one of the eyes, estimated from the depth of the fixation point, and, for each viewing direction, an intersection point with the plane of focus.

[0050] FIG. 11 shows a pair of two-way light field displays connected via a network.

[0051] FIG. 12 shows a light field camera and a light field display connected via a network.

[0052] FIG. 13A shows a schematic diagram of an array-based two-way light field display element with a liquid crystal lens in a passive state.

[0053] FIG. 13B shows a schematic diagram of the array-based two-way light field display element with the liquid crystal lens in an active state.

[0054] FIG. 14A shows a schematic diagram of an array-based two-way light field display element with dual liquid crystal lenses, with the first lens active.

[0055] FIG. 14B shows a schematic diagram of the array-based two-way light field display element with dual liquid crystal lenses, with the second lens active.

[0056] FIG. 15 shows a block diagram of a scanning light field display element.

[0057] FIG. 16 shows a block diagram of an RGB laser beam generator with multiple intensity modulators.

[0058] FIG. 17 shows a block diagram of a scanning light field camera element.

[0059] FIG. 18 shows a block diagram of a scanning two-way light field display element.

[0060] FIG. 19A shows a plan view of an optical design for the scanning two-way light field display element, with output rays.

[0061] FIG. 19B shows a front elevation of the optical design for the scanning two-way light field display element, with output rays.

[0062] FIG. 20 shows the angular reconstruction filter of FIG. 19A implemented using an array of lenslets.

[0063] FIG. 21A shows a plan view of the optical design for the scanning two-way light field display element, with input beams.

[0064] FIG. 21B shows a front elevation of the optical design for the scanning two-way light field display element, with input beams.

[0065] FIG. 22A shows a plan view of a biaxial MEMS scanner with an elevated mirror.

[0066] FIG. 22B shows a cross-sectional elevation of the biaxial MEMS scanner with an elevated mirror.

[0067] FIG. 23A shows the scanning mirror of FIG. 21A scanning a stationary beam corresponding to a fixed point source across a linear photodetector array.

[0068] FIG. 23B shows the photodetector array consisting of an analog photodetector array coupled with an analog shift register.

[0069] FIG. 24 shows a block diagram of a multi-element light field display.

[0070] FIG. 25A shows a plan view of an optical design for a two-way light field display, 5 elements wide, with output rays.

[0071] FIG. 25B shows a front elevation of the optical design for the two-way light field display, consisting of 10 rows of 5 elements, with output beams.

[0072] FIG. 25C shows a front elevation of the optical design for the two-way light field display, consisting of 5 rows of 10 rotated elements, with output beams.

[0073] FIG. 26 shows a plan view of one row of the two-way light field display, rotated as shown in FIG. 25B, with each element generating a beam corresponding to a single point source behind the display.

[0074] FIG. 27 shows a plan view of one row of the two-way light field display, rotated as shown in FIG. 25C, with each element generating a beam corresponding to a single point source behind the display.

[0075] FIG. 28 shows a plan view of one row of the two-way light field display, rotated as shown in FIG. 25B, with each element generating a beam corresponding to a single point source in front of the display.

[0076] FIG. 29 shows a plan view of one row of the two-way light field display, rotated as shown in FIG. 25C, with each element generating a beam corresponding to a single point source in front of the display.

[0077] FIG. 30 shows a block diagram of a multi-element light field camera.

[0078] FIG. 31A shows a plan view of the optical design for a two-way light field display, 5 elements wide, with input beams.

[0079] FIG. 31B shows a front elevation of the optical design for the two-way light field display, consisting of 10 rows of 5 elements, with input beams.

[0080] FIG. 31C shows a front elevation of the optical design for the two-way light field display, consisting of 5 rows of 10 rotated elements, with input beams.

[0081] FIG. 32 shows a plan view of one row of the two-way light field display, rotated as shown in FIG. 31B, with each element capturing a beam corresponding to a single point source in front of the display.

[0082] FIG. 33 shows a plan view of one row of the two-way light field display, rotated as shown in FIG. 31C, with each element capturing a beam corresponding to a single point source in front of the display.

[0083] FIG. 34A shows a cross-sectional side elevation of an oscillating two-way light field display.

[0084] FIG. 34B shows a cross-sectional side elevation of the oscillating two-way light field display, two display panels high.

[0085] FIG. 34C shows a cross-sectional back elevation of the oscillating two-way light field display.

[0086] FIG. 34D shows a cross-sectional back elevation of the oscillating two-way light field display, two display panels high and wide.

[0087] FIG. 35A shows a graph of vertical offset versus time for the oscillating display when directly driven.

[0088] FIG. 35B shows a graph of vertical offset versus time for the oscillating display when resonantly driven.

[0089] FIG. 36 shows an activity diagram for controlling the focus of a light field camera according to the viewers gaze.

[0090] FIG. 37 shows an activity diagram for controlling the focus of a light field camera according to the viewers fixation point.

[0091] FIG. 38 shows an activity diagram for displaying a light field stream from a light field camera.

[0092] FIG. 39 shows an activity diagram for displaying a captured light field.

[0093] FIG. 40 shows an activity diagram for displaying a synthetic light field.

[0094] FIG. 41 shows a block diagram of a two-way light field display controller.

[0095] FIG. 42A shows eye-directed fields of display elements of a light field display.

[0096] FIG. 42B shows the foveal field of an eye on a light field display.

[0097] FIG. 43 shows a block diagram of a two-way light field display controller optimised for viewer-specific operation.

DRAWINGS

Reference Numerals

[0098]	100 Ray of light field.
[0099]	102 Light field boundary.
[0100]	104 Ray intersection point with light field boundary.
[0101]	110 Light field video.
[0102]	112 Temporal interval.
[0103]	114 Temporal sampling period.
[0104]	116 Light field frame.
[0105]	118 Spatial field.
[0106]	120 Spatial sampling period.
[0107]	122 Light field view image.
[0108]	124 Angular field.
[0109]	126 Angular sampling period.
[0110]	128 Spectral radiance.
[0111]	130 Spectral interval.
[0112]	132 Spectral sampling basis.
[0113]	134 Radiance sample.
[0114]	136 Depth.
[0115]	138 Sampling focus.
[0116]	150 Light sensor array.
[0117]	152 Light sensor.
[0118]	154 Angular sampling beam.
[0119]	156 Angular sampling filter pinhole.
[0120]	158 Image plane.
[0121]	160 Spatial sampling filter lens.
[0122]	162 Spatial sampling beam.
[0123]	164 Image point.
[0124]	166 4D sampling beam.
[0125]	168 Object point.
[0126]	170 Object plane.
[0127]	180 Light emitter array.
[0128]	182 Light emitter.
[0129]	184 Angular reconstruction beam.
[0130]	186 Angular reconstruction filter pinhole.
[0131]	188 Spatial reconstruction filter lens.
[0132]	190 Spatial reconstruction beam.
[0133]	192 4D reconstruction beam.

- [0134] 200 Light field display.
- [0135] 202 Display output beam.
- [0136] 204 Virtual point source.
- [0137] 206 Wavefront.
- [0138] 210 Light field display element.
- [0139] 212 Element output beam.
- [0140] 220 Light field camera.
- [0141] 222 Camera input beam.
- [0142] 224 Real point source.
- [0143] 230 Light field camera element.
- [0144] 232 Element input beam.
- [0145] 240 Viewer eye.
- [0146] 242 Eye object point.
- [0147] 244 Eye pupil.
- [0148] 246 Axial input beam.
- [0149] 248 Eye image point.
- [0150] 250 Viewer.
- [0151] 252 Scene object.
- [0152] 254 Display element focus.
- [0153] 256 Viewer fixation point.
- [0154] 258 Viewer eye object plane.
- [0155] 300 Two-way light field display.
- [0156] 310 Two-way light field display element.
- [0157] 320 Network.
- [0158] 322 Two-way display controller.
- [0159] 324 Remote viewer.
- [0160] 326 Virtual image of remote viewer.
- [0161] 328 Local viewer.
- [0162] 330 Virtual image of local viewer.
- [0163] 332 Remote object.
- [0164] 334 Virtual image of remote object.
- [0165] 336 Local object.
- [0166] 338 Virtual image of local object.
- [0167] 340 Camera controller.
- [0168] 342 Display controller.
- [0169] 344 Tracking camera.
- [0170] 400 First positive lens.
- [0171] 402 Electrode.
- [0172] 404 Convex part of variable negative lens.
- [0173] 406 Variable negative lens.
- [0174] 408 Electrode.
- [0175] 410 Linear polarizer.
- [0176] 412 Second positive lens.
- [0177] 414 Output/input beam.
- [0178] 416 Second variable negative lens.
- [0179] 418 Switchable polarization rotator.
- [0180] 500 Scanned output beam.
- [0181] 502 Output view image.
- [0182] 504 Line scanner.
- [0183] 506 Frame scanner.
- [0184] 508 2D scanner.
- [0185] 510 Timing generator.
- [0186] 512 External frame sync.
- [0187] 514 Frame sync.
- [0188] 516 Line sync.
- [0189] 518 Sampling clock.
- [0190] 520 Radiance controller.
- [0191] 522 Beam generator.
- [0192] 524 Radiance modulator.
- [0193] 526 Output focus.
- [0194] 528 Output focus controller.
- [0195] 530 Output focus modulator.
- [0196] 540 Color beam generator.
- [0197] 542 Red beam generator.
- [0198] 544 Red radiance modulator.
- [0199] 546 Green beam generator.
- [0200] 548 Green radiance modulator.
- [0201] 550 Blue beam generator.
- [0202] 552 Blue radiance modulator.
- [0203] 554 First beam combiner.
- [0204] 556 Second beam combiner.
- [0205] 600 Scanned input beam.
- [0206] 602 Input view image.
- [0207] 604 Radiance sensor.
- [0208] 606 Radiance sampler.
- [0209] 608 Input focus.
- [0210] 610 Input focus controller.
- [0211] 612 Input focus modulator.
- [0212] 614 Beamsplitter.
- [0213] 700 Laser.
- [0214] 702 Angular reconstruction filter.
- [0215] 704 Variable output focus.
- [0216] 706 Beamsplitter.
- [0217] 708 Mirror.
- [0218] 710 Biaxial scanning mirror.
- [0219] 712 Mirror.
- [0220] 714 Variable input focus.
- [0221] 716 Fixed input focus.
- [0222] 718 Aperture.
- [0223] 720 Photodetector.
- [0224] 730 Angular reconstruction filter lenslet.
- [0225] 732 Collimated output beam.
- [0226] 734 Angular reconstruction beamlet.
- [0227] 740 Biaxial scanner platform.
- [0228] 742 Biaxial scanner platform hinge.
- [0229] 744 Biaxial scanner inner frame.
- [0230] 746 Biaxial scanner inner frame hinge.
- [0231] 748 Biaxial scanner outer frame.
- [0232] 750 Biaxial scanner mirror support post.
- [0233] 752 Biaxial scanner mirror.
- [0234] 760 Stationary input beam.
- [0235] 762 Shift-and-accumulate photodetector linear array.
- [0236] 764 Photodetector linear array.
- [0237] 766 Photodetector.
- [0238] 768 Analog shift register.
- [0239] 770 Analog shift register stage.
- [0240] 772 Analog-to-digital converter (ADC).
- [0241] 774 Beam energy sample value.
- [0242] 800 Oscillating display panel.
- [0243] 802 Oscillating display chassis.
- [0244] 804 Oscillating display frame.
- [0245] 806 Oscillating display cover glass.
- [0246] 808 Support spring.
- [0247] 810 Spring support bracket on panel.
- [0248] 812 Spring support bracket on chassis.
- [0249] 814 Actuator.
- [0250] 816 Rod.
- [0251] 818 Actuator support bracket on panel.
- [0252] 820 Actuator support bracket on chassis.
- [0253] 900 Detect face & eyes.
- [0254] 902 Estimate gaze direction.
- [0255] 904 Transmit eye positions & gaze direction.
- [0256] 906 Autofocus in gaze direction.
- [0257] 908 Estimate fixation point.
- [0258] 910 Transmit eye positions & fixation point.
- [0259] 912 Focus on fixation plane.
- [0260] 920 Capture light field frame.

[0261] 922 Transmit light field frame.
 [0262] 924 Resample light field frame.
 [0263] 926 Display light field frame.
 [0264] 930 Eye positions (datastore).
 [0265] 932 Fixation point (datastore).
 [0266] 934 Light field video (datastore).
 [0267] 936 Resample light field frame with focus.
 [0268] 938 3D animation model.
 [0269] 940 Render light field frame with focus.
 [0270] 950 Two-way panel controller.
 [0271] 952 Two-way element controller.
 [0272] 954 View image datastore.
 [0273] 956 Two-way element controller block.
 [0274] 958 2D image datastore.
 [0275] 960 Collimated view image datastore.
 [0276] 962 Network interface.
 [0277] 964 Input video interface.
 [0278] 966 Output video interface.
 [0279] 968 Display timing generator.
 [0280] 970 Panel motion controller.
 [0281] 972 High-speed data bus.
 [0282] 980 Display element field.
 [0283] 982 Display element eye field.
 [0284] 984 Foveal field.
 [0285] 986 Partial view image datastore.
 [0286] 988 Partial foveal view image datastore.

DETAILED DESCRIPTION OF PREFERRED EMBODIMENTS

Light Field Parameterization

[0287] FIG. 1A shows a representative ray **100** of a continuous 6D light field, traversing the boundary **102** of the volume of interest at an intersection point **104**. The radiance (L) of the ray **100** is a function of time (t), boundary position (via coordinates x and y), ray direction (via angles a and b), and wavelength (w).

[0288] While the radiance of the ray is strictly only defined at the boundary, i.e. at the intersection point **104**, additional knowledge of the transparency of the two volumes separated by the boundary can allow the ray's radiance to be extrapolated in either direction.

[0289] Radiance is a measure of radiant power per unit solid angle per unit area (measured in watts per steradian per square meter, $W/sr/m^2$). For an infinitesimal ray of a continuous light field, the radiance is defined for an infinitesimal solid angle and area.

[0290] For eventual display to a human, the radiance is usually sampled sparsely using either a triplet of basis functions related to the tristimulus color response of the human visual system, or a single basis function related to the human luminance response. These basis functions ensure proper band-limiting in the wavelength (w) dimension. For convenience the wavelength dimension is usually left implicit in most analysis. Thus a 6D light field becomes a 5D light field.

[0291] The time dimension (t) may be sampled at discrete time steps to produce a sequence of 4D light field frames analogous to 2D image frames in a conventional video sequence. To avoid motion blur, or just as a matter of practicality, proper band-limiting is often not applied to the time dimension when sampling or generating video, and this can lead to aliasing. This is typically ameliorated by sampling at a sufficiently high rate.

[0292] References in the literature to a 4D light field (and in the present specification, where appropriate) refer to a 4D light field frame, i.e. defined at a particular instant in time, with an implicit wavelength dimension.

[0293] FIG. 1B shows a class diagram for a sampled, i.e. discrete, 6D light field, structured as a light field video **110**.

[0294] The light field video **110** consists of a sequence of light field frames **116**, ordered by time (t), and captured over a particular temporal interval **112** with a particular temporal sampling period **114**.

[0295] Each light field frame **112** consists of an array of light field view images **122**, ordered by ray position (x and y), and captured over a particular spatial field **118** with a particular spatial sampling period **120**.

[0296] Each light field view image **122** consists of an array of spectral radiances **128**, ordered by ray direction (a and b), and captured over a particular angular field **124** with a particular angular sampling period **126**.

[0297] Each spectral radiance **128** consists of a sequence of radiance (L) samples **134**, ordered by wavelength (w), and captured over a particular spectral interval **130** according to a particular spectral sampling basis **132**. The spectral radiance **128** has an optional depth **136**, i.e. the depth of the scene in the ray direction, if known. The spectral radiance **128** also records the sampling focus **138** with which it was captured. The depth **136** and sampling focus **138** are discussed further below.

[0298] Each radiance (L) sample **134** records a scalar radiance value.

[0299] In this specification the term "beam" is used to refer to a bundle of rays, whose characteristics vary but are qualified in each context.

Light Field Sampling

[0300] FIGS. 2A, 2B, 3A and 3B illustrate an approach to band-limiting and sampling a continuous light field to obtain a discrete light field.

[0301] FIG. 2A shows a light sensor array **150** sampling the continuous light field with respect to ray direction for a particular ray position **104**. Each light sensor **152** of the array **150** samples a particular ray direction, and integrates the beam **154** surrounding the nominal ray **100**. This integration effects 2D low-pass filtering with respect to ray direction. The effective filter kernel is a non-ideal box filter corresponding to the spatial extent of the light sensor **152**. The light sensors are ideally closely packed to ensure adequate filter support. The angular sampling beam **154** is focused at an infinitesimal pinhole aperture **156**, which coincides with the ray position **104** on the boundary **102**.

[0302] The light sensor array **150** lies in a plane **158**, parameterized by ray direction angles a and b.

[0303] The angular field **124** is the angle subtended at the angular sampling filter pinhole **156** by the light sensor array **150**. The angular sampling period **126**, i.e. the inverse of the angular sampling rate, is the angle subtended by the center-to-center spacing of the light sensors **152**. The angular sample size (i.e. the filter support) is the angle subtended by the extent of the light sensor **152**. The angular sample count equals the angular field **124** divided by the angular sampling period **126**, i.e. the number of light sensors **152**.

[0304] FIG. 2B shows an array of lenses sampling the continuous light field with respect to ray position at the boundary **102**. Each lens **160** of the array samples a particular ray position, and integrates the parallel beam **162** surrounding the

nominal ray **100** by focusing the beam to a point **164** on the light sensor **152**. This integration effects 2D low-pass filtering with respect to position. The effective filter kernel is a non-ideal box filter corresponding to the spatial extent of the aperture of the spatial sampling filter lens **160**. The lenses are ideally closely packed to ensure adequate filter support.

[0305] The image distance is the distance from the second principal point of the lens **160** to the image plane **158**.

[0306] The spatial field **118** equals the extent of the bounding surface **102**. The spatial sampling period **120**, i.e. the inverse of the spatial sampling rate, is the center-to-center spacing of the spatial sampling filter lenses **160**. The spatial sample size (i.e. the filter support) is the area of the aperture of the lens **160**. The spatial sample count equals the spatial field **118** divided by the spatial sampling period **120**, i.e. the number of lenses **160**.

[0307] FIG. 3A shows the combined effect of the spatial extent of the light sensor **152** and the aperture of the lens **160** integrating sampling beam **166** to effect 4D low-pass filtering, i.e. with respect to direction and position simultaneously. The effective filter kernel is a 4D box filter, which provides reasonable but non-ideal band-limiting. It is difficult to do better than a box filter when integrating light spatially.

[0308] The scalar value obtained from the light sensor **152** is typically proportional to the time-integral of radiant power, i.e. radiant energy. It is convertible to a radiance sample **134** by dividing it by the 5D sample size (i.e. 1D exposure duration, 2D spatial sample size, and 2D angular sample size).

[0309] Note that the size of the light sensor **152** in the figures is exaggerated for clarity, and that the divergence of the (otherwise parallel) beam **166** due to angular sampling is therefore also exaggerated.

[0310] Low-pass filtering of a light field results in visible blurring. In the present sampling regime, blur is proportional to the diameter of beam **166**. This has two additive components: the angular sampling blur, which corresponds to the angular sampling filter, i.e. the diameter of angular sampling beam **154** in FIG. 2A; and the spatial sampling blur, which corresponds to the spatial sampling filter, i.e. the diameter of spatial sampling beam **162** in FIG. 2B.

[0311] FIG. 3B shows beam **166** focused at a point **168** in object space using a lens **160** with higher power than the lens **160** in FIG. 3A. The corresponding object distance is the distance from the object point **168** to the first principal point of the lens **160**. At the object point **168** (and in general on the object plane **170**) the spatial sampling blur is zero, and the beam diameter corresponds to the angular sampling blur alone.

[0312] The object sampling period, i.e. at the object plane **170**, equals the (tangent of the) angular sampling period **126** multiplied by the object distance.

[0313] When the object plane **170** is at infinity then the sampling beam **166** of FIG. 3A is obtained.

[0314] The convergence angle of the sampling beam **166** (or more properly the spatial sampling beam **162**) is the angle subtended by the aperture of the lens **160** at the object point **168**. Depth of field refers to a depth interval, bounded by a given threshold spatial sampling blur (or defocus blur), bracketing the object point **168**. The larger the convergence angle the more rapidly defocus blur changes with depth, and hence the shallower the depth of field (i.e. the shorter the interval). Depth of field is relatively shallower for object distances that are shorter and for apertures that are larger (i.e. corresponding to lower spatial sampling rates).

[0315] Adjusting the focus of the sampling beam **166** allows defocus blur at one depth to be eliminated at the expense of increasing defocus blur at other depths, while maintaining proper support for the 4D low-pass filter. This allows defocus blur to be traded between different regions of the light field, which is useful when blur minimisation is more important in some regions than others (e.g. regions corresponding to the surfaces of objects).

[0316] Changing focus does not affect the field of view or the total captured radiance, since each lens **160** captures essentially the same set of rays independent of focus.

[0317] If the sampling beam **166** is focused at infinity (as shown in FIG. 3A) its spatial sampling blur is constant and corresponds to the aperture of the lens **160**. Since angular sampling blur increases with object distance, the relative contribution of this constant spatial sampling blur decreases with distance. This indicates that there is a threshold object distance beyond which angular sampling blur becomes dominant, and that minimising blur by focusing the sampling beam **166** provides diminishing returns as the object distance increases beyond this threshold distance.

[0318] The focus of beam **166** is recorded in the discrete light field **110** as the sampling focus **138** associated with the spectral radiance **128**.

[0319] The optional depth **136** may be determined by range-finding (discussed below), and the sampling focus **138** may correspond to the depth **136**, e.g. when beam **166** is focused according to scene depth.

[0320] In the well-known two-plane parameterization of the 4D light field [Levoy96], the uv plane coincides with the light field boundary **102** and the st plane coincides with the object plane **170** (or equivalently the image plane **158**). The st plane is typically fixed, corresponding to fixed-focus sampling.

Light Field Reconstruction

[0321] The sampling regime used to capture a discrete light field **110**, including the focus **138** of each sample, is used as the basis for reconstructing the corresponding continuous light field.

[0322] A continuous physical 4D light field is reconstructed from a discrete 4D light field using a 4D low-pass filter. The filter ensures that the continuous light field is band-limited to the frequency content of the band-limited continuous light field from which the discrete light field was sampled.

[0323] FIGS. 4A, 4B, 5A and 5B illustrate an approach to band-limiting and reconstructing a continuous light field from a discrete light field. These figures mirror FIGS. 2A, 2B, 3A and 3B respectively, and the same reference numerals are used for corresponding parts where appropriate.

[0324] FIG. 4A shows a light emitter array **180** reconstructing a continuous light field with respect to ray direction for a particular ray position **104**. Each light emitter **182** of the array **180** reconstructs a particular ray direction, and generates the beam **184** surrounding the nominal ray **100**. This generation effects 2D low-pass filtering with respect to ray direction. The effective filter kernel is a non-ideal box filter corresponding to the spatial extent of the light emitter **182**. The light emitters are ideally closely packed to ensure adequate filter support. The angular reconstruction beam **184** is focused at an infinitesimal pinhole aperture **186**, which coincides with the ray position **104** on the boundary **102**.

[0325] FIG. 4B shows an array of lenses reconstructing the continuous light field with respect to ray position at the

boundary **102**. Each lens **188** of the array reconstructs a particular ray position, and generates the parallel beam **190** surrounding the nominal ray **100** by focusing from point **164** on the light emitter **182**. This generation effects 2D low-pass filtering with respect to position. The effective filter kernel is a non-ideal box filter corresponding to the spatial extent of the aperture of the lens **188**. The lenses are ideally closely packed to ensure adequate filter support.

[0326] FIG. 5A shows the combined effect of the spatial extent of the light emitter **182** and the aperture of the lens **188** generating reconstruction beam **192** to effect 4D low-pass filtering, i.e. with respect to direction and position simultaneously. The effective filter kernel is a 4D box filter, which provides reasonable but non-ideal band-limiting. It is difficult to do better than a box filter when generating light spatially.

[0327] The scalar value provided to the light emitter **182** is typically proportional to emitter power. The radiance sample **134** is convertible to emitter power by multiplying it by the 5D sampling period (i.e. the 1D temporal sampling period **114**, the 2D spatial sampling period **120**, and the 2D angular sampling period **126**), and dividing it by the actual on-time of the emitter (which is typically shorter than the temporal sampling period **114**). Note that if the 4D (spatial and angular) reconstruction filter support is smaller than the 4D sampling period then the same radiant power is simply delivered via a more compact beam.

[0328] Proper 4D reconstruction relies on the light emitter **182** emitting all possible rays between the extent of the light emitter **182** and the aperture of the lens **188**. This is satisfied if the emitter **182** is diffuse.

[0329] FIG. 5B shows beam **192** focused from a virtual object point (to the left of the array **180**, and not shown in FIG. 5B, but coinciding with object point **168** in FIG. 6B) using a lens **188** with lower power than the lens **188** in FIG. 5A.

[0330] When the virtual object plane is at infinity then the beam **192** of FIG. 5A is obtained.

[0331] The divergence angle of the reconstruction beam **192** (or more properly the spatial reconstruction beam **190**) is the angle subtended by the aperture of the lens **188** at the virtual object point. The reconstruction beam **192** has a depth of field, determined by its divergence angle, corresponding to the depth of field of the sampling beam **166** in FIG. 3B.

[0332] Adjusting the focus of reconstruction beam **192**, per the sampling focus **138**, allows it to be matched to the sampling beam **166** used to create the sample value.

[0333] The reconstruction beams **192** of FIGS. 5A and 5B match the sampling beams **166** of FIGS. 3A and 3B respectively, and this is illustrated explicitly in FIGS. 6A and 6B, where the left side of each figure shows the sampling beam **166** and the right side shows the matching reconstruction beam **192**.

Light Field Display

[0334] FIG. 7A shows an idealized light field display **200** emitting output beams **202** corresponding to two virtual point sources **204** constituting a very simple virtual scene. Each output beam **202** consists of spherical wavefronts **206**, each with its origin at respective point source **204**. The exit pupil of each output beam **202** at the surface of the display **200** equals the extent of the entire display.

[0335] For clarity, FIG. 7A shows only two point sources **204**. In practice the display **200** would emit beams from a

continuous set of point sources. Also, while not explicitly shown, the radiance cross-section of each beam **202** could be non-uniform.

[0336] To an observer situated in front of the light field display **200**, the display **200** would appear indistinguishable from a window onto a real scene containing the point sources **204**.

[0337] While FIG. 7A shows display **200** emitting diverging beams corresponding to virtual point sources **204** located behind the display, the display **200** could also emit converging beams corresponding to virtual point sources located in front of the display.

[0338] FIG. 7B shows a realization of the display **200**, segmented into an array of contiguous display elements **210**, each of which performs the reconstruction functions of the light emitter array **180** and lens **188** in FIG. 5B.

[0339] Each display element **210** is shown emitting output beams **212** corresponding to the point sources **204**, i.e. each display element **210** behaves in the same way as the overall display **200**, but with a reduced exit pupil equal to the extent of the display element **210**.

[0340] Each output beam **212** emitted by a display element **210** in FIG. 7B is focused at its respective point source **204**, thus the output beams **212** abut to form the wider output beams **202** emitted by the entire display **200** in FIG. 7A, with the same wavefronts **206**.

[0341] The segmented light field display **200** is configured to directly display a discrete 6D light field **110**. During display, the surface of the display **200** corresponds to the light field boundary **102** associated with the discrete light field, and the position of each display element **210** corresponds to a sampling position **104** (x, y) on the boundary. The direction of each beam **212** emitted by the display element corresponds to a sampling direction (a, b), and the average radiance of each beam **212** corresponds to the sampled spectral radiance **128**. The focus of each beam **212** corresponds to the sampling focus **138**.

[0342] Thus each display element **210** reconstructs, at a given time, the continuous light field corresponding to a single light field view image **122**, and the entire display **200** reconstructs, at a given time, the continuous light field corresponding to a single light field frame **116**. The display **200** thus reconstructs, over time, the continuous 6D optical light field corresponding to the discrete 6D light field video **110**.

[0343] For clarity, the spatial sampling period **120** illustrated in FIG. 7B is relatively large, while the angular sampling period **126** is relatively small. Thus the output beams **212**, each of which is associated with a single spectral radiance **128** within the discrete light field **110**, are shown to converge exactly at their respective virtual point source **204**. In practice the beams converge in a finite area rather than at a point, i.e. the point source is blurred in proportion to the angular sampling period **126**.

[0344] As is evident from FIG. 7B, the larger the spatial sampling period **120** the less angular object detail is displayed, and the larger the angular sampling period **126** the less spatial object detail is displayed. The former manifests as shallow depth of field, while the latter manifests as blur in the object plane.

[0345] The smaller the 4D sampling period (i.e. the higher the 4D sampling rate) the greater the fidelity of the light field display. However, for a fixed number of samples, it is possible to reduce object-plane blur at the cost of shallower depth of field.

Light Field Camera

[0346] FIG. 8A shows an idealized light field camera 220 capturing input beams 222 corresponding to two real point sources 224 constituting a very simple real scene. Each input beam 222 consists of spherical wavefronts, each with its origin at respective point source 224. The entry pupil of each input beam 222 at the surface of the camera 220 equals the extent of the entire camera.

[0347] For clarity, FIG. 8A shows only two point sources 224. In practice the camera 220 would capture beams from a continuous set of point sources. Also, while not explicitly shown, the radiance cross-section of each beam 222 could be non-uniform.

[0348] FIG. 8B shows a realization of the camera 220, segmented into an array of contiguous camera elements 230, each of which performs the sampling functions of the light sensor array 150 and lens 160 in FIG. 3B.

[0349] Each camera element 230 is shown capturing input beams 232 corresponding to the point sources 224, i.e. each camera element 230 behaves in the same way as the overall camera 220, but with a reduced entry pupil equal to the extent of the camera element 230.

[0350] Each input beam 232 captured by a camera element 230 in FIG. 8B is focused at its respective point source 224, thus the input beams 232 abut to form the wider input beams 222 captured by the entire camera 220 in FIG. 8A, with the same wavefronts.

[0351] The segmented light field camera 220 is configured to directly capture a discrete 6D light field 110. During capture, the surface of the camera 220 corresponds to the light field boundary 102 associated with the discrete light field, and the position of each camera element 230 corresponds to a sampling position 104 (x, y) on the boundary. The direction of each beam 232 captured by the display element corresponds to a sampling direction (a, b), and the average radiance of each beam 232 is captured as the spectral radiance 128. The focus of each beam 232 corresponds to the sampling focus 138.

[0352] Thus each camera element 230 samples, at a given time, the continuous light field corresponding to a single light field view image 122, and the entire camera 220 samples, at a given time, the continuous light field corresponding to a single light field frame 116. The camera 220 thus samples, over time, the continuous 6D optical light field corresponding to the discrete 6D light field video 110.

[0353] For clarity, the spatial sampling period 120 illustrated in FIG. 8B is relatively large, while the angular sampling period 126 is relatively small. Thus the input beams 232, each of which is associated with a single spectral radiance 128 within the discrete light field 110, are shown to converge exactly at their respective real point source 224. In practice the beams converge in a finite area rather than at a point, i.e. the point source is blurred in proportion to the angular sampling period 126.

Non-Planar Light Field Boundary

[0354] Although the figures show the light field boundary 102 associated with the light field display 200 and the light field camera 220 as planar, it may in practice assume any convenient shape.

Depth Perception

[0355] Creatures with foveal vision (such as humans) fixate on a point by rotating the eye (or eyes) so that the image of the

point is centered on the high-density foveal region of the retina. This maximises the sharpness of the perceived image. When the retinal images of two eyes are mentally fused into a single image during the process of stereopsis, the degree of eye convergence (or vergence) provides a crucial cue to the absolute depth of the fixation point.

[0356] In addition to rotating the eye(s) during fixation, creatures also adjust the shape of the lens of the eye to bring the point of fixation into focus on the retina. In this process of accommodation, the state of the muscles controlling the lens provides another important cue to absolute depth.

[0357] The human accommodation response curve shows over-accommodation to far stimuli and under-accommodation to near stimuli, with a typical cross-over (i.e. perfect accommodation) at an object distance of around 50 cm, and a typical minimum response of 0.5 diopters (2 m) for object distances greater than 2-3 m [Ongb 93, Palmer99, Plainis05]. Crucially, then, the human visual system never accommodates properly to far stimuli.

[0358] The vergence and accommodation responses are closely coupled, and any mismatch between the vergence and accommodation cues provided by a display can lead to viewer discomfort [Hoffman08].

[0359] Parallax refers to the difference in apparent position of an object when viewed from different viewpoints, with close objects exhibiting greater parallax than distant objects. Binocular disparity due to parallax supports relative depth perception during stereopsis, i.e. relative to the absolute depth of fixation. Motion parallax supports relative depth perception even with one eye.

Perception of a Focused Light Field

[0360] As illustrated in FIG. 7B, each output beam 212 corresponding to a point source 204 has its origin at the point source, i.e. each constituent ray of the beam 212 originates at the point source 204. Equivalently, the spherical wavefronts 206 of the beam 212 have their center of curvature at the point source 204. This ensures that a viewer perceives the parallax of point source 204 correctly both within any given beam 212 and across multiple beams 212, resulting in accurate binocular disparity and smooth motion parallax. The smaller the object distance the greater the divergence of each beam 212, and hence the more important the presence of intra-beam parallax. By contrast, fixed-focus 3D displays only provide parallax between different views, and provide incorrect (and therefore conflicting) parallax within any given view. Furthermore, autostereoscopic displays typically provide a modest number of views, resulting in only approximate binocular parallax and discontinuous motion parallax.

[0361] The correctly-centered spherical wavefronts 206 of the beams 212 also allow the viewer to accommodate to the correct depth of the corresponding point source 204, ensuring that the viewer's vergence and accommodation responses are consistent. This avoids the vergence-accommodation conflicts associated with fixed-focus 3D displays.

[0362] Using a relatively high angular sampling rate decouples the angular resolution of a light field display from the spatial sampling rate (see below). This contrasts with typical 3D displays where the spatial sampling rate determines the angular display resolution. For the present display 200, this allows the spatial sampling rate to be lower than with fixed-focus 3D displays. For a given overall (4D) sampling rate this in turn allows a relatively higher angular sampling rate.

[0363] The angular resolution of a focused light field display **200**, when displaying a virtual object at a particular object distance (r) behind the display, and viewed at a particular distance (d) in front of the display, is the angle (g) subtended, at the viewpoint, by one object sampling period (h) (i.e. on the object plane), i.e. $g=h/(r+d)$ (for small g).

[0364] The object sampling period (h) is a function of the angular sampling period **126** (q) and the object distance (r), i.e. $h=qr$ (for small q). Hence $g=qr/(r+d)$.

[0365] The angular sampling period **126** (q) therefore represents the minimum light field display resolution. As the object distance (r) approaches infinity or the viewing distance (d) approaches zero (i.e. in both cases as $r/(r+d)$ approaches one) the display resolution converges with the angular sampling period **126** (q).

[0366] The light field display **200** can therefore be configured to match the human perceptual limit, for any viewing geometry, by configuring its angular sampling period **126** (q) to match the maximum angular resolution of the eye (about 60 cycles per degree [Hartridge22], equivalent to an angular sampling period of approximately 0.008 degrees). For a 40-degree field of view this equates to an angular sample count of 4800.

[0367] The light field display resolution for a given viewing distance (d) and object distance (r) can significantly exceed the angular sampling period **126** (q) when the viewing distance exceeds the object distance. For example, if the viewing distance is four times the object distance, the display resolution is five times the angular sampling period **126**, and for a 40-degree angular field **124** an angular sample count of 960 is sufficient to match the human perceptual limit.

[0368] If the angular sampling period **126** (q) is sufficiently large (such as for typical autostereoscopic displays) then the spatial sampling period **120** (s) determines the angular display resolution (g). The angular resolution (g) is then the angle subtended by one spatial sampling period **120** (s) at the display surface, i.e. $g=s/d$ (for small g). The complete equation for the angular resolution of a light field display is then: $g=\min(s/d, qr/(r+d))$.

[0369] The foregoing calculations represent the best case, in that they ignore the imperfect human accommodation response. The perceived resolution of a light field display can be improved by (at least partially) matching its focus to the actual human accommodation response to a given depth stimulus, rather than to the depth itself. This can include matching the known accommodation response of an individual viewer (including the effect of spectacles, if worn). However, any deviation in focus from the proper depth-determined focus leads to parallax error, and this error increases with decreasing object distance. With increasing object distance, however, parallax error is increasingly masked by angular sampling blur. A compromise, then, is to select a threshold object distance beyond which light field focus is fixed. This divides the light field focus regime into a fixed-focus far-field regime and a variable-focus near-field regime. The fixed-focus far-field threshold can be as close as the typical minimum accommodation response (2 m), or significantly larger (including, in the limit, infinity).

Equivalence of Scene Focus and Viewer Focus

[0370] FIG. 9A shows the eye **240** of a viewer located in the reconstructed light field of a virtual point source **204**. The light field is reconstructed by segmented display **200**. The eye is focused at an object point **242** coinciding with the virtual

point source **204**. The input beam **246** admitted by the pupil of the eye, a sub-beam of one of the output beams **212**, is focused to a point **248** on the retina. The image of the point source **204** on the retina is therefore sharp.

[0371] FIG. 9B shows the object point **242** now closer to the display **200** than the virtual point source **204**. The image point **248** corresponding to the point source **204** is now in front of the retina, and the image of the point source on the retina is therefore blurred. This is as it should be, i.e. it matches reality.

[0372] FIG. 9C shows the display **200** now displaying the light field of a point source coinciding with the translated object point **242**. The input beam **246** is now focused at object point **242** rather than original point source **204**, so is once again in focus on the retina (at image point **248**). Since the input beam is not in focus at point source **204**, the image of point source **204** on the retina remains blurred (and by the same amount as in FIG. 9B). This is again as it should be.

[0373] For clarity, FIGS. 9A through 9C only show a single object point **242**, on the optical axis of the eye **240**. The “plane” of focus is the locus of all such points, and is an approximately spherical surface with a radius equal to the object distance, centred at the first nodal point of the eye.

[0374] The equivalence of what the viewer perceives in FIGS. 9B and 9C indicates that there are two useful modes of operation for displaying a focused light field. In the first mode the display is focused on objects in the scene. In the second mode the display is focused according to the viewer’s focus.

Light Field Display Focus Strategies

[0375] The advantage of scene-based focus is that the reconstructed light field is intrinsically multi-viewer. One disadvantage is that the depth of the scene must be known or determined (discussed below). Another disadvantage is that output focus may need to be varied for each sample, requiring fast focus switching. In addition, a single depth needs to be chosen for each sample, and this may require a compromise when significant depth variations are present within the sampling beam.

[0376] If the focus modulation rate of the display element **210** is significantly lower than the sampling rate **114**, then multiple depths can be supported via multiple display passes, i.e. one pass per depth. The output focus of each display element **210** is then adjusted for each pass according to its corresponding scene depth in that pass. However, because the number of distinct depths within a view image **122** is typically larger than the practical number of display passes, the set of depths supported for a given display element is likely to be a compromise. One way to choose the set of depths is to estimate the full range of depths within the view image **122** of a display element and then identify the most common depth clusters. Intermediate depths can then be displayed using depth-weighted blending [Hoffman08].

[0377] The advantage of viewer-specific focus is that focus can be varied relatively slowly, and depth variations within a single sample are intrinsically correctly handled. The disadvantage is that the reconstructed light field is viewer-specific, and that the viewer must therefore be tracked. It has the additional disadvantage that the light field must be captured (or synthesized) with the correct focus, or refocused before display.

[0378] The sharpness of the refocused light field can be increased by recording multiple spectral radiance samples **128** per direction (a, b), each with a different sampling focus **138**. Sharpness is particularly increased if each sampling

focus **138** corresponds to an actual object depth within the sampling beam **166**, whether directly or via a transmitted or reflected path.

[0379] The viewer-specific light field view image **122** for each display element **210** is obtained by integrating, for each direction, all rays passing through the object point **242** (or disc, more properly) for that direction and through the aperture of the display element. When the light field **110** is captured via a light field camera **220**, this integration may be performed by focusing each camera element **230** accordingly.

[0380] In the viewer-specific focus mode, then, the fixation point of the viewer is constantly tracked, and each display element **110** is individually controlled to emit a viewer-specific light field focused according to the depth of the fixation point.

[0381] Multiple viewers can be supported via multiple display passes, i.e. one pass per viewer. Alternatively, display focus can be controlled by a single user, and other users can passively view the display at that focus, i.e. in the same way they would view a fixed-focus light field display.

[0382] In a hybrid mode, one or more display passes may be viewer-specific, while one or more additional display passes may be scene-based. For example, two display passes can be used to provide a viewer-specific pass, a finite-focus pass for near scene content, and an infinite-focus pass for far scene content.

[0383] During an optimised viewer-specific display pass output is only generated in the direction of the viewer, as discussed further below in relation to FIG. **42A**. This means that a viewer-specific display pass is only visible to the target viewer, and may only consume a fraction of the frame period, depending on the implementation of the display element **210**.

[0384] A viewer-specific display pass will typically utilise less than 10% of the angular field **124**, and if the display element **210** is scanning (as described in detail further below), then, at least in one dimension, the display pass will only consume a corresponding fraction of the frame period. A reduced-duration viewer-specific frame is referred to as a sub-frame hereafter.

[0385] Unlike traditional head-tracking 3D displays where the displayed content is viewer-specific, a light field display **200** operating in viewer-specific mode displays viewer-independent content with viewer-specific focus. If the viewer changes their point of fixation or moves relative to the display then the display focus may need to be updated, but this can happen relatively slowly because the viewer is always embedded in a valid (if not necessarily completely optimal) reconstructed light field, and the human accommodation response is relatively slow (i.e. of the order of several hundred milliseconds).

Viewer-Specific Focus Modes

[0386] FIGS. **10A** through **10D** illustrate two strategies for displaying a viewer-specific light field.

[0387] FIG. **10A** shows a viewer **250** gazing at a light field display **200** emitting a light field corresponding to a virtual scene consisting of several objects **252**. A tracking system incorporated in or associated with the display **200** tracks the face of the viewer **250** and hence the locations of the viewer's two eyes **240**.

[0388] FIG. **10B** shows the location of one of the eyes **240** used to determine a viewing direction through each display element **210**, and thus, for each viewing direction, an intersection point **254** with a scene object **252**. The focus of each

display element is shown set according to the depth of the corresponding intersection point **254**.

[0389] FIG. **10C** shows the tracking system used to track the gaze direction of each of the viewer's two eyes **240**, and hence to estimate their fixation point **256**. Assuming fixation and accommodation are synchronised, as they are under normal circumstances, the viewer's focus can be estimated from the depth of the fixation point **256**.

[0390] FIG. **10D** shows the plane of focus **258** of one of the eyes **240**, estimated from the depth of the fixation point **256**, and, for each viewing direction, an intersection point **254** with the plane of focus. The focus of each display element is again shown set according to the depth of the corresponding intersection point **254**.

[0391] The first viewer-specific mode, shown in FIG. **10B**, represents a hybrid mode which relies on scene depth information and face detection, but does not require gaze estimation. It is referred to as the position-based viewer-specific focus mode.

[0392] The second viewer-specific mode, shown in FIGS. **10C** and **10D**, does not rely on scene depth information but does require gaze estimation. It is referred to as the gaze-directed viewer-specific focus mode.

[0393] Although FIG. **10D** shows the output focus set according to the position of an individual eye **240**, for fixation depths that are large compared with the distance separating the eyes the output focus of a particular display element **210** will differ sufficiently little between the two eyes that an average output focus can be used to serve both eyes during a single display pass. Any display element **210** that contributes to foveal vision in one or the other eye (as discussed later in this specification in relation to FIG. **42B**) should, however, be focused for the corresponding eye.

[0394] The position-based and gaze-directed focus modes are complementary. The gaze-directed mode produces more accurate focus, but relies on gaze estimation which becomes decreasingly tractable as the distance between the viewer and the display increases. The position-based mode relies on face detection, which remains tractable over larger distances, and the accuracy of position-based scene focus increases with distance, since the angle subtended by a display element **210** decreases with distance.

[0395] The two modes can therefore be used in tandem, with the operative mode selected individually for each viewer according to the distance between the display and the viewer.

Choice of Focus Strategy

[0396] A suitable focus strategy depends on how the display is used, i.e. the number of viewers, their typical viewing distances, and the nature of the displayed scenes. It also depends on the capabilities of a particular implementation of the light field display **200**, in particular on the focus modulation rate.

[0397] The minimum viewing object distance is the sum of the minimum displayed object distance and the minimum viewing distance. If the minimum viewing object distance is larger than the far-field threshold then a single fixed-focus display pass is sufficient.

[0398] If the minimum displayed object distance is larger than the far-field threshold then the far-field regime applies independent of viewing distance, and viewers need not be tracked. For example, the display **200** may be simulating a window onto a distant exterior scene.

[0399] If the minimum displayed object distance is smaller than the far-field threshold then the near-field regime applies wherever the minimum viewing object distance is smaller than the far-field threshold, and viewers may need to be tracked.

[0400] If the focus modulation rate of the light field display **200** matches the sampling rate **114** then a viewer-independent near-field light field can be displayed in a single pass.

[0401] If the light field display **200** is used as a near-eye display (NED) then there is only a single viewing eye. The gaze-directed viewer-specific focus mode may be effectively used, e.g. based on the fixation depth inferred from the vergence of the two eyes, and the focus modulation rate only has to match the relatively slow human accommodation mechanism, which takes several hundred milliseconds to refocus (less than 4 Hz).

[0402] If the light field display **200** is used by multiple relatively close viewers, then multiple passes of gaze-directed viewer-specific focus can be effectively utilised.

[0403] If the display **200** supports sub-frames then multiple display passes may be made during a single frame duration. If not, then the number of display passes is limited by the ratio of the temporal sampling interval **114** to the frame duration (assuming the temporal sampling interval **114** is perceptually based and therefore cannot be compromised).

[0404] If the eye-specific sub-frame period is T_{eye} , the focus switching time is T_{focus} , the frame period is T_{frame} , the number of full-frame passes is N_{full} , and the temporal sampling period **114** is T_s , then the available number of eye-specific passes N_{eye} is given by: $N_{eye} = \text{floor}((T_s - (T_{frame} * N_{full})) / (T_{focus} + T_{eye}))$

[0405] For illustrative purposes it is assumed that the frame period T_{frame} is half the sampling period T_s . This allows two full-frame passes when the number of eye-specific passes N_{eye} is zero, and the following number of eye-specific passes when the number of full-frame passes N_{full} is one: $N_{eye} = \text{floor}(T_{frame} / (T_{focus} + T_{eye}))$. Hence $T_{focus} = (T_{frame} / N_{eye}) - T_{eye}$.

[0406] For illustrative purposes it is further assumed that the required number of eye-specific passes T_{eye} is four, and that the sub-frame duration T_{eye} is 10% of T_{frame} . The maximum allowed focus switching time T_{focus} is then given by: $T_{focus} = T_{frame} * 0.15$.

[0407] Assuming a frame rate of 100 Hz, i.e. a frame period T_{frame} of 10 ms (corresponding to a temporal sampling period T_s **114** of 20 ms (50 Hz)), this equates to a focus switching time T_{focus} of 1.5 ms. Assuming a frame rate of 200 Hz, it equates to a focus switching time T_{focus} of 750 μ s.

[0408] If the display element **210** is scanning, and it is assumed that viewers are distributed horizontally with respect to the display **200**, then it is advantageous to assign the fast scan direction to the vertical dimension of the display to allow focus to be varied horizontally, i.e. in the slow scan direction, during a single display pass (assuming sufficiently fast focus switching). This allows multiple eye-specific focus zones to be created during a single (full-frame) display pass, and provides an alternative to making multiple viewer-specific sub-frame display passes.

[0409] The choice of focus strategy during capture by a light field camera **220** follows the same principles as discussed above in relation to display by a light field display **200**. This includes adjusting the capture focus according to the position and/or gaze of one or more viewers of a light field display **200**, i.e. if the camera **220** is capturing a light field that

is being displayed in real time by the light field display **200**, as discussed in more detail below.

Depth Estimation

[0410] The optional depth **136** associated with the spectral radiance **128** records the scene depth within the sampling beam **166**. It may represent a compromise when significant depth variations are present within the sampling beam, e.g. due to partial occlusions, transparency or reflections. For example, it may represent the depth to the first sufficiently opaque surface along the nominal sampling ray **100**. Alternatively, as discussed above, multiple depths **136** may be recorded for each direction (a, b).

[0411] The depth **136** may be used for a number of purposes, including displaying the light field with scene-based focus (as discussed above), estimating the fixation point of a viewer (discussed below), light field compression (discussed below), and depth-based processing and interaction in general.

[0412] When the light field **110** is synthetic, i.e. generated from a 3D model, the depth of the scene is known. When the light field **110** is captured from a real scene, the depth may be determined by range-finding.

[0413] Range-finding may be active, e.g. based on time-of-flight measurement [Kolb09, Oggier11], or passive, e.g. based on image disparity [Szeliski99, Seitz06, Lazaros08] or defocus blur [Watanabe96]. It may also be based on a combination of active and passive techniques [Kolb09]. Range-finding is discussed further below.

Two-Way Light Field Display

[0414] It is advantageous to combine the functions of a light field display **200** and a light field camera **220** in a single device, due both to the symmetry of application and the symmetry of operation of the two devices. Such a device is hereafter referred to as a two-way light field display.

[0415] FIG. 11 shows a pair of two-way light field displays **300** connected via a network **320**. Each two-way light field display **300** is segmented into an array of contiguous two-way light field display elements **310**, each of which performs the functions of light field display element **210** and light field camera element **220**.

[0416] The figure shows a remote viewer **324**, at the top, interacting with the remote two-way light field display **300**, and a local viewer **328**, at the bottom, interacting with the local two-way light field display **300**. Each two-way display **300** is controlled by a respective display controller **322**, described in more detail later in this specification.

[0417] The remote viewer **324** is accompanied by a remote object **332**, while the local viewer **328** is accompanied by a local object **336**. The local viewer **328** is shown fixating on a virtual image **334** of the remote object **332**, while the remote viewer **324** is shown fixating on a virtual image **338** of the local object **336**. The remote display **300** also displays a virtual image **330** of the local viewer, and the local display **300** displays a virtual image **326** of the remote viewer **324**.

[0418] Each viewer may be tracked by the display controller **322** of their respective two-way display **300**, using view images **122** captured via the two-way display **300** (or via separate tracking cameras, discussed below). As previously described (and described in more detailed further below),

each viewer's face position or gaze direction may be used to control the capture focus of the corresponding two-way light field display 300.

[0419] The use of a pair of two-way light field displays 300 rather than conventional displays and cameras allows significantly improved communication between the remote viewer 324 and local viewer 328, promoting a strong sense of shared presence. For example, each viewer can determine where the other viewer is looking or pointing, and objects can be held up close to the surface of the two-way display 300 for close inspection by the other viewer.

[0420] FIG. 11 also makes it clear that if the two two-way displays 300 are mounted back-to-back then they function as a virtual two-way window, i.e. they (and the intervening space) become effectively invisible.

[0421] FIG. 12 shows a one-way configuration, consisting of a remote light field camera 220, at the top, and a local light field display 200, at the bottom, connected via a network 320.

[0422] The figure shows a local viewer 328, at the bottom, viewing the display 200. The light field camera 220 is controlled by a camera controller 340, while the light field display 200 is controlled by a display controller 342. The controllers are described in more detail later in this specification.

[0423] The remote scene contains a remote object 332, and the local viewer 328 is shown fixating on a virtual image 334 of the remote object 332.

[0424] The viewer 328 may be tracked by the display controller 342, using images captured via two or more tracking cameras 344 connected to the controller 342. As previously described, the viewer's face position or gaze direction may be used to control the capture focus of the light field camera 220.

[0425] In the remainder of this specification any reference to a light field display 200 (and light field display element 210) should be taken as equivalent to the display function of a two-way light field display 300 (and two-way light field display element 310), and vice versa. Likewise, any reference to a light field camera 220 (and light field camera element 230) should be taken as equivalent to the camera function of a two-way light field display 300 (and two-way light field display element 310), and vice versa.

Face Detection and Gaze Estimation

[0426] As discussed above, the light field display 200 may use knowledge of the position and gaze direction of a viewer to generate a viewer-specific output light field, including with viewer-specific focus and a viewer-specific angular field.

[0427] Depending on the distance between a viewer and the light field display 200, the display can variously make use of knowledge of the three-dimensional position of the viewer, the positions of the viewer's eyes, the lines of gaze of the eyes, the fixation depth of the eyes, and the fixation point of the eyes, to generate viewer-specific output. The viewer's gaze direction may only be estimated with useful accuracy when the viewer is relatively close to the display, while the position of the viewer's face and eyes may be estimated with useful accuracy even when the viewer is relatively distant from the display.

[0428] Robust and high-speed face detection in digital images is typically based on a cascade of classifiers trained on a database of faces [Jones06]. Multiple face detectors can be trained and used together to cover a wide range of head poses [Jones03].

[0429] Approximate eye detection is typically intrinsic to face detection, and more accurate eye positions can be esti-

mated after face detection [Hansen10]. Detection is also easily extended to other useful features of the face and eyes, including the eyebrows, nose, mouth, eyelids, scleras, irises and pupils [Betke00, Lienhart03, Hansen10].

[0430] Face detection and subsequent feature detection is performed on images from multiple cameras to obtain estimates of feature positions in three dimensions, using images either from two or more calibrated tracking cameras 344, or from two or more light field camera elements 230 used for tracking (e.g. located at the corners of the light field camera 220). The use of multiple tracking cameras also provides better coverage of potential viewer positions and poses. Feature positions may also be estimated from depth data obtained by active range-finding (as discussed above).

[0431] For the purposes of gaze estimation, the display 200 includes multiple near-infrared (NIR) light sources to allow the line of gaze of each eye to be estimated from the difference between the position of its pupil and the position of the specular reflection (glint) of each light source on its cornea [Shih00, Duchowski07, Hansen10]. The NIR light sources may be powered only on alternate video frames to assist with the detection of their reflections in an image [Amir03]. To assist with pupil detection the display 200 may incorporate an additional NIR light source, positioned on or close to the axis of one of the tracking cameras, to produce a bright retinal reflection through the pupil of each eye. This light source may be powered on alternate video frames to the glint-producing light sources.

[0432] The line of gaze of an eye corresponds to the optical axis of the eye, while the desired line of sight is determined by the retinal position of the slightly off-axis fovea. The line of sight may be estimated from the line of gaze using an estimate of the position of the fovea. The position of the fovea can either be assumed (e.g. based on population data), or can be estimated via calibration. Explicit calibration typically requires the viewer to fixate on a set of targets. Implicit calibration relies on inferring when the viewer is fixating on known scene points. Calibration can be performed anew each viewing session, or calibration data can be stored and retrieved when the viewer interacts with the display. For example, it may be retrieved based on recognising the viewer's face [Turk92, Hua11], or it may be based on another form of identification mechanism, such as a credential provided by the viewer.

[0433] The fixation point of the viewer may be estimated from the intersection point of the lines of sight of the viewer's two eyes. The fixation point may be refined using knowledge of the depth of the scene, under the assumption that the viewer is likely to be fixating on a surface point in the scene. Alternatively, the fixation depth may be estimated from the vergence of the two lines of sight, without estimating an explicit fixation point.

[0434] As an alternative to active gaze estimation using NIR illumination, gaze estimation may be passive, i.e. based only on images of the viewer's eyes under ambient illumination [Hansen10]. This relies on estimating the relative positions and shapes of key features such as the corners of the eyes, the eyelids, the boundary between the sclera and iris (the limbus), and the pupil, relative to the overall pose of the head. Passive gaze estimation is generally less accurate than active gaze estimation.

[0435] For the purposes of both active and passive gaze estimation, the display 200 may include additional steerable narrow-field-of-view (FOV) tracking cameras 344 for obtain-

ing more detailed images of viewers' eyes. Selected camera elements **230**, if scanning, may also be used as steerable narrow-FOV tracking cameras by narrowing and angling their angular fields of view.

Two-Way Light Field Display Implementation

[0436] In a preferred embodiment the segmented two-way light field display **300** captures and displays a light field video **110**, i.e. a succession of light field frames **116**, and operates with a sufficiently short temporal sampling period **114** to minimise or eliminate perceived flicker, i.e. ideally at a frame rate of at least 60 Hz, the peak critical flicker fusion (CFF) frequency.

[0437] As a motivating example, and for the purposes of illustrative calculations in the remainder of this specification, a two-way light field display **300** with the following parameters is used: a temporal sampling period **114** of 10 ms (i.e. a frame rate of 100 Hz, assuming one frame per temporal sampling period); a spatial sampling period **120** of 2 mm; a spatial field **118** (i.e. display surface extent) that is 1000 mm wide by 500 mm high; hence a spatial sample count of 500 by 250; an angular sampling period **126** of 0.04 degrees; an angular field of 40 degrees by 40 degrees; hence an angular sample count of 1000 by 1000; an RGB spectral sampling basis **132**; and 12-bit radiance **134** samples.

[0438] This illustrative two-way display **300** configuration has a throughput of 4E13 radiance samples/s in each direction (i.e. display and capture).

[0439] Note that many applications allow significantly lower frame rates, sampling periods and sample counts.

Display Luminance and Power

[0440] The luminance of the daylight terrestrial sky ranges up to about 10,000 cd/m² (candela per square meter), which equates to a radiance (in the visible spectrum) of about 15 W/sr/m². Reproducing this using the illustrative display configuration equates to an output power of about 20 uW (microwatts) per display element **310**, and a total output power of about 3 W for the entire display **300**. A typical indoor light source may have a luminance an order of magnitude larger, i.e. 100,000 cd/m², equating to 200 uW per display element and 30 W for the entire display.

[0441] Any radiance samples **134** that exceed the maximum radiance of the display **300** can be clamped, or all radiance values can be scaled within the available range.

Array-Based Two-Way Light Field Display Element

[0442] FIGS. **13A** and **13B** show a schematic diagram of one embodiment of a two-way light field display element **310** of the two-way light field display **300**.

[0443] The two-way element **310** consists of a light sensor array **150** overlaid by a transparent light emitter array **180**. Focusing is provided by a first fixed-focus positive lens **400**, a variable-focus negative lens **406**, and a second fixed-focus positive lens **412**.

[0444] The variable-focus negative lens **406** may be any suitable lens with controllable focus, as discussed in more detail in relation to the scanning light field display element later in this specification.

[0445] The variable-focus negative lens **406** shown in FIGS. **13A** and **13B** consists of a nematic liquid crystal cell sandwiched between a concave face and a planar face. The concave face is formed by an adjacent convex part **404**. The

liquid crystal is birefringent, with light polarized parallel to the director experiencing a higher (extraordinary) refractive index (n_{1e}), and light polarized perpendicular to the director experiencing a lower (ordinary) refractive index (n_{1o}). For illustrative purposes an ordinary index of 1.5 and an extraordinary index of 1.8 are used, parameters representative of commercially-available liquid crystal materials such as Merck E44.

[0446] The liquid crystal cell is further sandwiched between a pair of transparent electrodes **402** and **408** (e.g. ITO). When no voltage is applied across the electrodes, as illustrated in FIG. **13A**, the director (indicated by the orientation of the small ellipses in the figure) follows the horizontal rubbing direction. When a saturation voltage is applied, as illustrated in FIG. **13B**, the director becomes vertically aligned with the applied field.

[0447] The refractive index (n_2) of the convex part **404** is approximately matched to the ordinary refractive index (n_{1o}) of the liquid crystal. The power of the variable-focus lens **406** is therefore close to zero when the saturation voltage is applied, while the (negative) power of the variable-focus lens **406** is at a maximum when no voltage is applied, as a function of the difference between the two refractive indices (n_{1e} and n_2) and the curvature of the convex part **404**. Intermediate voltages are used to select focus values between these extremes.

[0448] When the (negative) power of the variable-focus lens **406** is at a maximum the two-way element **310** produces the diverging beam of FIG. **13A**. When the lens power is at a minimum the two-way element **310** produces the converging beam of FIG. **13B**.

[0449] The liquid crystal variable-focus lens **406** works in conjunction with a linear polarizer **410**, which ensures that only light polarized parallel to the default director (FIG. **13A**) passes into or out of the two-way display element **310**, i.e. only light focused by the variable-focus lens **406**.

[0450] As an alternative to using a single liquid crystal variable-focus lens **406** in conjunction with a linear polarizer **410**, two liquid crystal variable-focus lenses with orthogonal rubbing directions can be used to focus light of all polarizations [Berreman80].

[0451] The combined power of the fixed-focus positive lenses **400** and **412** is balanced against the power of the variable-focus negative lens **406** to yield a focus range from short negative through to short positive, as illustrated in FIG. **13A** and FIG. **13B** respectively.

[0452] During two-way use of the element **310**, display and capture may be time-multiplexed, with each frame period divided into a (relatively longer) display interval and a (relatively shorter) capture interval, with the variable-focus lens **406** refocused appropriately before each interval.

[0453] As shown in FIGS. **14A** and **14B**, if the variable-focus lens **406** isn't fast enough to be refocused twice per frame then a pair of variable-focus lenses **406** and **416** with orthogonal rubbing directions can be used, one dedicated to display focus and the other dedicated to capture focus. In this case a fast switchable polarization rotator **418** [Sharp00] can be used to selectively rotate the light polarization zero or ninety degrees, and so select between display and capture focus.

[0454] FIG. **14A** shows the first variable-focus lens **406** active to collimate the beam **414** for display. FIG. **14B** shows the second variable-focus lens **416** active to collimate the beam **414** for capture. For clarity the figures show the unused

variable-focus lens (406 or 416) made inoperative via an applied saturation voltage. In practice, however, the unused lens is actually made inoperative by the polarization rotator 418, making the voltage applied to it irrelevant.

[0455] Each light sensor 152 of the light sensor array 150 is preferably an active pixel sensor (APS) [Fossum04] so that the entire array can be exposed simultaneously during the capture interval and then subsequently read out.

[0456] For color applications, each light emitter 182 of the light emitter array 180 is preferably a full-color emitter such as a stack of red, green and blue OLEDs [Aziz10]; and each light sensor 152 may be a full-color sensor such as a sensor stack [Merrill05], or a sensor array with color filters. In addition, each light emitter 182 and light sensor 152 may utilize any of the implementation options discussed in relation to the scanning light field display element below.

[0457] Each light emitter 182 and/or light sensor 152 may also support time-of-flight range-finding, as discussed in relation to the scanning light field display element below.

[0458] The variable-focus lenses 406 and 416 are shown with inhomogeneous gaps, allowing the use of simple electrodes. Since the speed of liquid crystal rotation decreases with decreasing gap size, homogeneous gaps can be used to increase the speed of rotation, although this necessitates the use of multi-segment electrodes [Lin11].

[0459] There are several disadvantages to using an array-based light field display element. Since each light emitter 182 is typically a diffuse emitter, only a portion of the generated light is actually emitted through the exit pupil of the display element. Since the size of the emitter array 180 is constrained by the spatial sampling period 120 (since this constrains the width of the display element), the number of angular samples may be overly constrained. And given practical limits on the complexity of the lenses used to focus the output from the display element (and input to the two-way display element), it is difficult to achieve high off-axis beam quality.

[0460] These limitations are avoided in the scanning display element 210, scanning camera element 230, and scanning two-way display element 310 described next.

Scanning Light Field Display Element

[0461] FIG. 15 shows a block diagram of a scanning embodiment of the light field display element 210 of the light field display 200.

[0462] The display element 210 scans an output beam of light 500 in two-dimensional raster fashion across the 2D angular field 124, and for each direction (a, b) modulates the beam to produce the desired radiance 134 specified in the output light field view image 502, which is a view image 122 of a light field video 110.

[0463] Over the duration of a single pulse (described below) the beam 500 corresponds to a particular output beam 212 in FIG. 7B, and to the reconstruction beam 192 in FIG. 5B.

[0464] The scanning display element 210 relies on the persistence of vision to induce the perception of a continuous optical light field throughout the angular field of view 124.

[0465] The beam 500 is scanned in the line direction by fast line scanner 504 (with an illustrative line rate of 100 kHz), and in the orthogonal (frame) direction by slow frame scanner 506 (with an illustrative frame rate of 100 Hz).

[0466] The fast line scanner 504 and slow frame scanner 506 may be separate, or may be combined in a 2D (biaxial) scanner.

[0467] The scanners are controlled by timing generator 510, which itself is controlled by an external frame sync signal 512, which is shared with other display elements 210. The frame scanner 506 is controlled by a frame sync signal 514 derived from the external frame sync signal 512, while the line scanner 504 is controlled by a line sync signal 516.

[0468] The radiance controller 520 controls the radiance of the output beam. Under the control of a sampling clock 518 from the timing generator 510, it reads the next radiance value 134 from the output view image 502 and generates a signal to control the radiance of the output beam.

[0469] If the angular scan velocity of the fast scanner 504 is angle-dependent (e.g. because the fast scanner is resonant) then the timing generator 510 adjusts the sampling clock 518 accordingly to ensure a constant angular sampling period 126.

[0470] The beam generator 522 generates the light beam, and the radiance modulator 524 modulates the radiance of the beam, typically in response to a beam power signal from the radiance controller 520. Implementation choices are described below.

[0471] The pulse duration should be matched to the angular sampling period 126 to ensure proper reconstruction. If a shorter pulse (of correspondingly higher power) is used, then proper reconstruction can be effected optically, as described below in relation to FIG. 20.

[0472] As described earlier, the required beam power is obtained by multiplying the required radiance 134 by the 5D sampling period (i.e. the 1D temporal sampling period 114, the 2D spatial sampling period 120, and the 2D angular sampling period 126), and dividing it by the pulse duration.

[0473] The pulse duration is obtained by dividing the angular sampling period 126 by the angular scan velocity of the fast scanner 504. If the angular scan velocity is angle-dependent (e.g. because the fast scanner is resonant), then the pulse duration is also angle-dependent.

[0474] The scanned output beam 500 may be focused according to an output focus source 526. The output focus source 526 may comprise an array of focus values each associated with a beam direction, i.e. corresponding to the sampling focus 138 associated with the spectral radiance 128. Alternatively it may comprise a single focus value which may change from one frame to the next (or at some other rate). Output focus controller 528 retrieves the focus value (or the next focus value, controlled by the sampling clock 518 from the timing generator 510), and generates a signal to control the focus of the output beam.

[0475] The output focus modulator 530 modulates the focus of the beam according to the signal from the output focus controller 528. Implementation choices are described below. If the display 200 is only required to operate in the fixed-focus far-field regime then the output focus modulator 530 may impart fixed focus on the beam, i.e. it may consist of a simple fixed-focus lens.

[0476] The display element 210 optionally incorporates multiple beam generators 522 and radiance modulators 524 to generate multiple adjacent beams 500 simultaneously.

Beam Generator

[0477] The beam generator 522 may be monochromatic, but is more usefully polychromatic. FIG. 16 shows a block diagram of a polychromatic beam generator and radiance modulator assembly 540, which replaces the beam generator 522 and radiance modulator 524 of FIG. 15.

[0478] The polychromatic beam generator and radiance modulator assembly **540** includes a red beam generator **542** and radiance modulator **544**, a green beam generator **546** and radiance modulator **548**, and a blue beam generator **550** and radiance modulator **552**. Each radiance modulator is responsive to respective signals from the radiance controller **520** shown in FIG. 15. The modulated red and green beams are combined via beam combiner **554**. The resultant beam is combined with the modulated blue beam via beam combiner **556**. The beam combiners may be dichroic beam combiners capable of combining beams of different wavelengths with high efficiency. To maximise the reproducible gamut the red, green and blue beam generators **542**, **546** and **550** ideally have central wavelengths close to the prime color wavelengths of 450 nm, 540 nm and 605 nm respectively [Brill98].

[0479] The beam generator **522** (or beam generators **542**, **546** and **550**) may incorporate any suitable light emitter, including a laser [Svelto10], laser diode, light-emitting diode (LED), fluorescent lamp, and incandescent lamp. Unless the emitter is intrinsically narrowband (e.g. the emitter is a laser, laser diode, or LED), the beam generator may incorporate a color filter (not shown). Unless the emitted light is collimated, with adequately uniform power across the full beam width, the beam generator may include conventional collimating optics, beam expansion optics, and/or beam-shaping optics (not shown).

[0480] The radiance modulator **524** may be intrinsic to the beam generator **522** (or beam generators **542**, **546** and **550**). For example, the beam generator may be a semiconductor laser which allows its power and pulse duration to be modulated directly by modulating its drive current.

[0481] If the radiance modulator **524** is distinct from the beam generator then the beam generator (or its light emitter) may be shared between a number of display elements **310**. For example, a number of display elements may share a lamp, or may share a single laser source via a holographic beam expander [Shechter02, Simmonds11].

[0482] Each color light emitter may be particularly effectively implemented using a semiconductor laser, such as a vertical-cavity surface-emitting laser (VCSEL) [Lu09, Higuchi10, Kasahara11]. A VCSEL produces a low-divergence circular beam that at a minimum only requires beam expansion.

[0483] Frequency-doubling via second harmonic generation (SHG) [Svelto10] provides an alternative to direct lasing at the target wavelength.

Radiance Modulator

[0484] If the radiance modulator **524** is distinct from the beam generator then it may consist of any suitable high-speed light valve or modulator, including an acousto-optic modulator [Chang96, Saleh07], and an electro-optic modulator [Maserjian89, Saleh07]. In the latter case it may exploit the Franz-Keldysh effect or the quantum-confined Stark effect to modulate absorption, or the Pockels effect or the Kerr effect to modulate refraction and hence deflection. The radiance modulator may include optics (not shown) to manipulate the beam before and/or after modulation, i.e. to optimise the coupling of the beam and the modulator (e.g. if there is a mismatch between the practical aperture of the modulator and the width of the beam before and/or after the modulator).

[0485] If the modulation is binary then intermediate radiances may be selected by temporally dithering the beam, i.e. pseudorandomly opening and closing the valve throughout

the nominal pulse duration with a duty cycle proportional to the required power. Dithering reduces artifacts in the reconstructed light field.

[0486] For the illustrative display configuration the required radiance modulation rate is 100 MHz (or an order of magnitude more if the modulation is binary). Both acousto-optic and electro-optic modulators support this rate, as do modulators that are intrinsic to the beam generator.

Focus Modulator

[0487] The output focus modulator **530** may utilise any suitable variable-focus lens, including a liquid crystal lens [Berreman80, Kowel86, Naumov99, Lin11], a liquid lens [Berge07], a deformable membrane mirror [Nishio09], a deformable-membrane liquid-filled lens [Fang08], an addressable lens stack [Love09], and an electro-optic lens (e.g. exploiting the Pockels effect or Kerr effect to modulate refraction) [Shibaguchi92, Saleh07, Jacob07, Imai11].

[0488] An addressable lens stack [Love09] consists of a stack of N birefringent lenses, each with a different power (e.g. half the power of its predecessor), and each preceded by a fast polarization rotator (e.g. [Sharp00]). The 2^N possible settings of the binary rotators yield a corresponding number of focus settings. For example, 10 lenses yield 1024 focus settings.

[0489] Fast polarization rotators can also be used to select among a small number of variable-focus lenses (as described in relation to FIGS. 14A and 14B). Such a lens consists of a stack of N variable-focus birefringent lenses, each preceded by a fast polarization rotator. One pair of rotators is enabled at a time to select the variable-focus lens bracketed by the pair (the first rotator selects the lens; the second rotator deselects subsequent lenses). This allows fast switching between variable focus settings, even if the variable focus lenses themselves are relatively slow. Each variable-focus lens in the stack can then be dedicated to one display pass (which may be viewer-specific or scene-specific), and the rotators can be used to rapidly select the appropriate lens for each display pass in turn. The stack optionally includes an additional rotator after the final lens to allow the final polarization of the beam to be constant, e.g. if the optical path contains polarization-sensitive downstream components.

[0490] For the illustrative display configuration the required focus modulation rate is 100 MHz to support per-sample focus, a modest multiple of 100 Hz to support multiple single-focus display passes (e.g. for multiple viewers), and around 4 Hz to support single-viewer gaze-directed focus. All of the variable-focus lens technologies described above support a 4 Hz focus modulation rate. Lens stacks utilising polarization rotators support modulation rates in excess of 1 kHz. Electro-optic lenses support modulation rates in excess of 100 MHz.

Line and Frame Scanners

[0491] The fast line scanner **504** and slow frame scanner **506** may each utilise any suitable scanning or beam-steering mechanism, including a (micro-) electromechanical scanning mirror [Neukermans97, Gerhard00, Bernstein02, Yan06], an addressable deflector stack ('digital light deflector') [Titus99], an acousto-optic scanner [Vallese70, Kobayashi91, Saleh07], and an electro-optic scanner [Saleh07, Naganuma09, Nakamura10].

[0492] Most scanner technologies can support the 100 Hz illustrative frame rate. Fast scanner technologies such as resonant microelectromechanical scanners and electro-optic scanners can support the 100 kHz illustrative line rate.

[0493] If the fast line scanner 504 is resonant then it may monitor (or otherwise determine) its own angular position and provide the timing generator 510 with angular position information to assist the timing generator with generating an accurate sampling clock 518.

[0494] Microelectromechanical scanners provide a particularly good combination of scan frequency and angular field, and are described in more detail later in this specification.

Scanning Light Field Camera Element

[0495] FIG. 17 shows a block diagram of a scanning embodiment of the light field camera element 230 of the light field camera 220.

[0496] The camera element 230 scans an input beam of light 600 in two-dimensional raster fashion across the 2D angular field 124, and for each direction (a, b) samples the beam to produce the desired radiance 134 in the input light field view image 602, which is a view image 122 of a light field video 110.

[0497] Over the duration of a single exposure (discussed below) the beam 600 corresponds to a particular input beam 232 in FIG. 8B, and to the sampling beam 166 in FIG. 3B.

[0498] The beam 600 is scanned in the line direction by fast line scanner 504 (with an illustrative line rate of 100 kHz), and in the orthogonal (frame) direction by slow frame scanner 506 (with an illustrative frame rate of 100 Hz). Implementation choices for the scanners are as described above in relation to the scanning display element 210.

[0499] The scanners are controlled by timing generator 510, which itself is controlled by an external frame sync signal 512, which is shared with other camera elements 230. The frame scanner 506 is controlled by a frame sync signal 514 derived from the external frame sync signal 512, while the line scanner 504 is controlled by a line sync signal 516.

[0500] The radiance sensor 604 senses the radiance of the beam, or, more typically, a quantity representative of the radiance, such as beam energy (i.e. beam power integrated over time). Implementation choices are described below.

[0501] The radiance sampler 606, controlled by a sampling clock 518 from the timing generator 510, samples the radiance-representative value (e.g. beam energy) from the radiance sensor 604, and converts it to a linear or non-linear (e.g. logarithmic) radiance value 134 which it writes to the input view image 602. Implementation choices are described below.

[0502] As described earlier, the radiance 134 may be obtained by dividing a sampled beam energy value by the 5D sample size (i.e. 1D exposure duration, 2D spatial sample size, and 2D angular sample size).

[0503] The nominal maximum sample exposure duration is obtained by dividing the angular sampling period 126 by the angular scan velocity of the fast scanner 504. If the angular scan velocity is angle-dependent (e.g. because the fast scanner is resonant), then the exposure duration is also angle-dependent.

[0504] To improve the signal to noise ratio of the captured radiance 134, the effective exposure duration can be

increased beyond the nominal maximum exposure duration by using a sensor array as described below in relation to FIG. 23A and FIG. 23B.

[0505] To ensure proper band-limiting, the radiance sensor 604 nominally has an active spatial extent that matches the angular sampling period 126. However, when coupled with the maximum sample exposure duration this produces blur in the fast scan direction. To avoid such blur, either the exposure duration needs to be reduced or the spatial extent of the sensor 604 in the fast scan direction needs to be reduced. The latter approach can be realised by implementing the sensor 604 using a linear array of narrow photodetectors, as also described below in relation to FIG. 23A and FIG. 23B.

[0506] The scanned input beam 600 may be focused according to an input focus source 608. The input focus source 608 may comprise an array of focus values each associated with a beam direction, i.e. corresponding to the sampling focus 138 associated with the spectral radiance 128. Alternatively it may comprise a single focus value which may change from one frame to the next (or at some other rate). Input focus controller 610 retrieves the focus value (or the next focus value, controlled by the sampling clock 518 from the timing generator 510), and generates a signal to control the focus of the input beam.

[0507] The input focus modulator 612 modulates the focus of the beam according to the signal from the input focus controller 610. Implementation choices for the input focus modulator 612 are the same as for the output focus modulator 530, as discussed above. If the camera 220 is only required to operate in the fixed-focus far-field regime then the input focus modulator 612 may impart fixed focus on the beam, i.e. it may consist of a simple fixed-focus lens

Radiance Sensor

[0508] The radiance sensor 604 may be monochromatic, but is more usefully polychromatic. If polychromatic, it may utilize a stacked color sensor [Merrill05], or an array of sensors with color filters.

[0509] The sensor 604 may incorporate any suitable photodetector(s), including a photodiode operating in photoconductive or photovoltaic mode, a phototransistor, and a photoresistor.

[0510] The sensor 604 may incorporate analog storage and exposure control circuitry [Fossum04].

Radiance Sampler

[0511] The radiance sampler 606 may incorporate any analog-to-digital converter (ADC) with suitable sampling rate and precision, typically with a pipelined architecture [Levinson96, Bright00, Xiaobo10]. For the illustrative display configuration the sampling rate is 100 Msamples/s and the precision is 12 bits. The sampler 606 may incorporate multiple ADCs to convert multiple color channels in parallel, or it may time-multiplex conversion of multiple color channels through a single ADC. It may also utilise multiple ADCs to support a particular sampling rate.

[0512] The sampler 606 may incorporate a programmable gain amplifier (PGA) to allow the sensed value to be offset and scaled prior to conversion.

[0513] Conversion of the sensed value to a radiance 134 may be performed before or after analog-to-digital conversion.

Time-of-Flight Range Finding

[0514] The light field camera **220** is optionally configured to perform time-of-flight (ToF) range-finding [Kolb09]. The camera then includes one or more light emitters for illuminating the scene with ToF-coded light. The ToF-coded light is reflected by the scene and is detected and converted to a depth by each camera element **230** every sampling period.

[0515] The radiance sensor **604** and radiance sampler **606** may be configured to perform ToF range-finding by incorporating circuitry to measure the phase difference between the coding of the outgoing light and the coding of the incoming light [Kolb09, Oggier11].

[0516] When configured to perform ToF range-finding the sampler **606** writes an estimated depth **136** to the input view image **602** every sampling period.

[0517] The ToF-coded light is ideally invisible, e.g. near-infrared (NIR). The sensor **604** may sense the ToF-coded light using a photodetector that is also used for sensing visible light, or the sensor **604** may include a dedicated photodetector for ToF-coded light.

[0518] An alternative to the camera providing one or more ToF-coded light emitters, each camera element **230** may, if also configured as a display element **210** (see below), emit its own ToF-coded light. The beam generator **522** may incorporate a light emitter for ToF-coded light, such as an NIR light emitter.

[0519] If necessary, face detection can be used to disable ToF range-finding for any sample (x, y, a, b) that would transmit ToF light into an eye.

Scanning Two-Way Light Field Display Element

[0520] FIG. 18 shows a block diagram of a scanning two-way light field display element **310** of the two-way light field display **300**. It combines the functions of the light field display element **210** and the light field camera element **230** shown in FIG. 15 and FIG. 17 respectively.

[0521] In the scanning two-way light field display element **310**, the line scanner **504**, frame scanner **506** and the timing generator **510** are shared between the display and camera functions of the element.

[0522] A beamsplitter **614** is used to separate the output and input optical paths. It may be any suitable beamsplitter, including a polarizing beamsplitter (discussed further below), and a half-silvered (or patterned) mirror.

[0523] In the scanning two-way light field display element **310** display and capture occur simultaneously, except when the angular field **124** is visibility-based (as discussed later in this specification) when it may vary significantly between display and capture.

Optical Design of Scanning Two-Way Light Field Display Element

[0524] FIG. 19A shows a plan view of an optical design for the scanning two-way light field display element **310**. The traced rays show the output optical path in operation, i.e. the element is generating output beam **500**. FIG. 19B shows the corresponding front elevation.

[0525] The height of the two-way element is the spatial sampling period **120**. The width of the two-way element **310** is approximately twice the spatial sampling period **120**.

[0526] Where the optical design is illustrated with particular component choices, note that it could be implemented using other equivalent components, such as discussed in pre-

vious sections. This includes the use of reflecting components in place of transmitting components and vice versa.

[0527] The design goal for the output optical path is to generate the output beam **500** so that it properly reconstructs, for a given direction (a, b), the corresponding 4D slice of the (bandlimited) continuous light field.

[0528] A laser **700** is used to produce a collimated beam **500** with a width as close as possible to the spatial sampling period **120**. The beam may be expanded and/or shaped (by additional components not shown) after being generated by the laser **700**. The laser **700** implements the beam generator **522** described in previous sections.

[0529] An angular reconstruction filter **702** is used to induce spread in the output beam equal to the angular sampling period **126**. The angular reconstruction filter **702** is discussed in more detail below, in relation to FIG. 20.

[0530] A variable-focus lens **704** is used to control the focus of the output beam. It implements the output focus modulator **530**.

[0531] A beamsplitter **706** is used to split the output and input optical paths. It implements the beamsplitter **614**.

[0532] A fixed mirror **708** deflects the output beam to a biaxial scanning mirror **710**, described in the next section. The scanning mirror **710** scans the output beam **500** across the angular field **124**. It implements both the line scanner **504** and the frame scanner **506**.

[0533] As an alternative, the biaxial scanning function may be implemented using two separate uniaxial scanning mirrors. In this configuration the fixed mirror **708** is replaced by a fast uniaxial scanning mirror (which implements the line scanner **504**), and biaxial scanning mirror **710** is replaced by a relatively slower uniaxial scanning mirror (which implements the frame scanner **506**).

[0534] FIG. 19A shows the biaxial scanning mirror **710**, and hence output beam **500**, at three distinct angles, corresponding to the center and the two extremes of the angular field **124**.

[0535] The angular reconstruction filter **702** can be implemented using a (possibly elliptical) diffuser [Qi05], or using an array of lenslets **730** as shown in FIG. 20. The purpose of the angular reconstruction filter is to induce spread in the output beam equal to the angular sampling period **126**, and the use of lenslets **730** allows the spread angle to be precisely controlled. Each lenslet **730** acts on the input beam **732** to produce a focused output beamlet **734**. Since the input beam **732** is collimated, the induced spread angle is the angle subtended by the diameter of the lenslet **730** at the focal point of the lenslet. In order to decouple the induced spread from the beam focus induced by the downstream variable-focus lens **704**, the focal point of the lenslet **730** is ideally placed on the first principal plane of the variable-focus lens **704** (at least approximately).

[0536] The larger the number of lenslets **730**, the more uniform the overall output beam, which is the sum of the individual beamlets **734**. The smaller the diameter of each lenslet **730**, the shorter its focal length needs to be to induce the same spread angle, thus the smaller the gap between the angular reconstruction filter **702** and the variable-focus lens **704** needs to be. In practice the array of lenslets **730** may be molded into the face of the variable-focus lens **704**.

[0537] If the output pulse duration matches the angular sampling period **126** (and scanning is continuous rather than discrete in the fast scan direction) then the output beam spread angle is already correct in the fast scan direction, and spread

only needs to be induced in the slow scan direction. In this case each lenslet 730 may be a cylindrical lens oriented in a direction perpendicular to the slow scan direction.

[0538] FIG. 21A shows a plan view of the optical design for the two-way light field display element 310. The traced rays show the input optical path in operation, i.e. the element is sampling input beam 600. FIG. 21B shows the corresponding front elevation.

[0539] The design goal for the input optical path is to sample the input beam 600 so that it properly filters, for a given direction (a, b), the corresponding 4D slice of the continuous light field.

[0540] The biaxial scanning mirror 710 (or pair of uniaxial scanning mirrors) scans the input beam 600 across the angular field 124, as described above for the output optical path.

[0541] The fixed mirror 708 and beamsplitter 706 deflect the input beam to fixed mirror 712, which deflects the beam through variable-focus lens 714.

[0542] The variable-focus lens 714 is used to control the focus of the input beam. It implements the input focus modulator 612.

[0543] The variable-focus lens 714 is followed by a fixed-focus lens 716, which focuses the (nominally collimated) input beam, via an aperture 718, onto a photodetector 720. The photodetector 720 implements the radiance sensor 604.

[0544] For color sensing, the photodetector 720 may consist of a photodetector stack [Merrill05], or a photodetector array with color filters.

[0545] The laser 700 may produce a substantially polarized beam (i.e. because it incorporates a polarizing Brewster window as its exit mirror), in which case it is efficient for the beamsplitter 706 to be polarizing, i.e. to split the outgoing and incoming beams based on polarization [vonGutten97]. Further, if the variable-focus lenses 704 and 714 are birefringent (e.g. they are liquid-crystal lenses), they then only need to act on their respective beam polarization and are thus simplified. Even if the laser 700 does not intrinsically produce a highly polarized beam, it may incorporate or be followed by a polarizer for this purpose (not shown).

Biaxial Scanning Mirror

[0546] A uniaxial microelectromechanical (MEMS) scanner typically consists of a mirror attached to a frame by a pair of perfectly elastic torsional hinges, and is driven to rotate about the hinges via an electrostatic, magnetic or capacitive coupling between the mirror and a driver. In a biaxial MEMS scanner [Neukermans97], the inner frame holding the mirror is attached to a fixed outer frame via a further pair of hinges arranged orthogonally to the mirror hinges, allowing the inner frame to be driven to rotate orthogonally to the mirror. The mirror is typically driven resonantly while the inner frame is not.

[0547] In a typical biaxial MEMS scanner the inner and outer frames surround the mirror, and so the area of the mirror is a fraction of the footprint of the device. This makes such a device non-optimal for use in a light field display where the relative aperture of the scanner is important. This can be ameliorated by elevating the mirror above the scanning mechanism, as is the practice in digital micromirror devices (DMDs) [Hornbeck96, DiCarlo06].

[0548] FIG. 22A shows a plan view of an example biaxial MEMS scanner 710 with an elevated mirror, but otherwise of conventional design [Neukermans97, Gerhard00, Bernstein02, Yan06]. A central platform 740 is attached by tor-

sional hinges 742 to an inner frame 744. The inner frame 744 is attached by orthogonally-arranged torsional hinges 746 to a fixed outer frame 748. The central platform 740 is driven to rotate about the hinges 742, while the inner frame 744 is driven to rotate in the orthogonal direction about the hinges 746. A post 750, mounted on the platform 740, holds a mirror 752 (shown in outline) elevated above the scanning mechanism.

[0549] FIG. 22B shows a cross-sectional front elevation of the biaxial MEMS scanner 710, showing the mirror 752 elevated above the scanning mechanism by the post 750. The elevation of the mirror 752 above the scanning mechanism is chosen to accommodate the maximum scan angle.

[0550] FIG. 22B does not show the drive mechanisms, which may be of any conventional design as described above. By way of example, the central platform 740 may incorporate a coil for conducting an alternating current, thus producing a time-varying magnetic field which interacts with the field of a permanent magnet below the platform (not shown) to produce the required time-varying torque. Likewise, the inner frame 744 may incorporate a coil whose field interacts with the field of a permanent magnet.

[0551] For present purposes, to support the illustrative line rate, the central platform 740 is driven resonantly [Turner05] and implements the fast line scanner 504, while the inner frame 744 is driven directly and implements the slow frame scanner 506.

[0552] As previously mentioned, control logic associated with the scanner 710 may monitor (or otherwise determine) the angular position of the central platform 740 in the resonant scan direction [Melville97, Champion12] for the purposes of assisting the timing generator 510 with generating an accurate sampling clock 518.

Extending Exposure Duration Using a Photodetector Array

[0553] The nominal exposure duration of a single light field sample during a scan is limited by the angular sampling period 126, and may therefore be very short. However, it is possible to deploy a linear photodetector array parallel to the fast scan direction, in place of a single photodetector 720, to extend the exposure duration.

[0554] FIG. 21A, as described above, shows the scanning mirror 710 scanning the moving input beam 600 across the angular field 124. Equivalently, FIG. 23A shows, via a simplified configuration which excludes extraneous optical components, the scanning mirror 710 scanning a stationary beam 760 corresponding to a fixed point source 224 across the photodetector, here replaced by a linear photodetector array 762 consisting of M photodetectors.

[0555] If samples are taken from the linear photodetector array 762 at precisely the rate at which the stationary beam 760 is scanned across it, then M time-successive samples from the M photodetectors can be summed to yield a sample value with an effective exposure duration M times longer than the nominal exposure duration.

[0556] As indicated in FIG. 23A, the linear photodetector array 762 covers an angular field M samples wide, representing M successive periods of the sampling clock 518. At a given time t these samples correspond to times ranging from t minus M/2 to t plus M/2, and M successive samples are being accumulated in parallel at any given time.

[0557] To avoid vignetting when using a linear photodetector array 762, the angular field 124 must be reduced by M times the angular sampling period 126.

[0558] While sample readout and summation can be carried out using digital logic, a relatively high sampling clock rate 518 (e.g. 100 MHz for the illustrative configuration) motivates an analog design.

[0559] To this end, FIG. 23B shows the photodetector array 762 consisting of an analog photodetector array 764 coupled with an analog shift register 768. Each period of the input sampling clock 518 the shift register 768 is shifted up, and the value from each photodetector 766 is added to the corresponding shift register stage 770. The value shifted into the first (bottom) shift register stage 770 is zero. The value shifted out of the last (top) shift register stage 770 is converted, via an analog-to-digital converter (ADC) 772, to a beam energy digital sample value 774. This in turn is converted to a radiance 134 as previously described. The ADC 772 may be any suitable ADC as previously described.

[0560] While the analog photodetector array 764 and the analog shift register 768 may be distinct, in some practical implementations they can be closely integrated. For example, if a bucket brigade device (BBD) [Sangster77, Patel78] is used as the analog shift register 768, then photodiodes 766 can be directly integrated into its storage nodes 770. And if a linear charge-coupled device (CCD) [Tompsett78] is used as the analog photodetector array 764, it can intrinsically also be operated as an analog shift register 768.

[0561] The analog photodetector array 764 can also be implemented separately from the analog shift register 768, for example as a standard array of active pixel sensors (APSs) [Fossum04], and the analog shift register can be implemented for example as a standard bucket brigade device (BBD), augmented with a third clock signal to control the transfer of charge from the photodetector array 764.

[0562] The effective exposure duration can be further increased by accumulating samples in the slow scan direction. This is achieved by deploying an array of M' linear photodetector arrays 762 to simultaneously capture M' adjacent lines of samples. During capture, M' sample values 774 are then produced every period of the sampling clock 518, rather than just one, and each such sample 774 is added (once converted to a radiance) to its corresponding radiance 134 in the input view image 602. The total radiance 134 is scaled to the longer exposure duration by dividing it by M' .

[0563] For the illustrative display configuration, setting $M=M'=100$ (i.e. each $1/10$ of the angular field 124) yields an exposure duration of 100 us.

[0564] In addition to increasing the effective exposure duration, the linear photodetector array 742 can be used to capture sharper samples by incorporating a multiple K of narrower photodetectors 746 (and shift register stages 770) per angular sampling period 126, and clocking the entire device the multiple K of the sampling clock 518. An additional analog storage node, inserted between the last shift register stage 770 and the ADC 772, is then used to accumulate K successive analog samples, with the combined value being digitized and read out according to the sampling clock 518.

[0565] Just as the radiance sensor 604 (and hence the photodetector 720) may be configured for ToF range-finding, so may the photodetector array 762. For example, if ToF range-finding is based on phase measurement [Kolb09, Oggier11], then the photodetector array 762 may be configured to accumulate phase samples in parallel.

Arrays of Two-Way Light Field Display Elements

[0566] FIG. 24 shows a simplified block diagram of an array of two-way light field display elements 310 operating in display mode. The 2D scanner 508 represents both the 1D line scanner 504 and the 1D frame scanner 506.

[0567] FIG. 25A shows a plan view of the optical design of one row of a two-way light field display 300, operating in display mode. The display consists of an array of two-way light field display elements 310, each generating an output beam 500. The array is shown at a single instant in time, with each beam pointing in the same direction. Each beam has the same, slightly divergent, focus.

[0568] FIG. 25B shows a corresponding front elevation of the display 300. Successive display elements 310 are rotated 180 degrees to improve the uniformity of the output.

[0569] FIG. 25C shows the front elevation rotated 90 degrees.

[0570] For clarity, FIGS. 25A, 25B and 25C only show a small number of two-way display elements 310. In practice a two-way light field display 300 can contain any number of elements 310, e.g. numbering in the thousands or millions. For the illustrative configuration it contains 125,000 display elements.

[0571] FIG. 26 shows a plan view of one row of the display 300, rotated as shown in FIG. 25B, with each element 310 generating a beam 500 corresponding to a single point source behind the display, hence at different times during their scan cycles. The gaps in the output are due to the double width of the display element 310 relative to the spatial sampling period 120.

[0572] FIG. 27 shows a plan view of one row of the display 300, rotated as shown in FIG. 25C, with each element 310 generating a beam 500 corresponding to a single point source behind the display, hence at different times during their scan cycles. The gaps in the output shown in FIG. 26 are now essentially eliminated because the display elements 310 are rotated so that their width matches the spatial sampling period 120.

[0573] FIG. 28 shows a plan view of one row of the display 300, rotated as shown in FIG. 25B, with each element 310 generating a beam 500 corresponding to a single point source 204 in front of the display, hence at different times during their scan cycles. The gaps in the output are again due to the double width of the display element 310 relative to the spatial sampling period 120.

[0574] FIG. 29 shows a plan view of one row of the display 300, rotated as shown in FIG. 25C, with each element 310 generating a beam 500 corresponding to a single point source 204 in front of the display, hence at different times during their scan cycles. The gaps in the output shown in FIG. 28 are now essentially eliminated because the display elements 310 are rotated so that their width matches the spatial sampling period 120.

[0575] FIG. 30 shows a simplified block diagram of an array of two-way light field display elements 310 operating in camera mode.

[0576] FIG. 31A shows a plan view of the optical design of one row of a two-way light field display 300, operating in camera mode. The display consists of an array of two-way light field display elements 310, each capturing an input beam 600. The array is shown at a single instant in time, with each beam pointing in the same direction. Each beam has the same, slightly convergent, focus.

[0577] FIG. 31B shows a corresponding front elevation of the display 300. Successive display elements 310 are rotated 180 degrees to improve the uniformity of the input.

[0578] FIG. 31C shows the front elevation rotated 90 degrees.

[0579] FIG. 32 shows a plan view of one row of the display 300, rotated as shown in FIG. 31B, with each element 310 capturing a beam 600 corresponding to a single point source 224 in front of the display, hence at different times during their scan cycles. The gaps in the input are due to the double width of the display element 310 relative to the spatial sampling period 120.

[0580] FIG. 33 shows an plan view of one row of the display 300, rotated as shown in FIG. 31C, with each element 310 capturing a beam 600 corresponding to a single point source 224 in front of the display, hence at different times during their scan cycles. The gaps in the input shown in FIG. 32 are now essentially eliminated because the display elements 310 are rotated so that their width matches the spatial sampling period 120.

Oscillating Display

[0581] As described in relation to FIG. 26, FIG. 28 and FIG. 32, the gaps in the output and input are due to the double width of the display element 310 relative to the spatial sampling period 120. This can be ameliorated by oscillating the array of two-way display elements 310 between two positions that are a distance of one spatial sampling period 120 apart, and displaying and/or capturing half of a light field frame 116 at each position.

[0582] More generally, beyond displaying (or capturing) one half frame in one of two positions, it is possible to display (or capture) 1/N frame in one of N positions, in either one spatial dimension or both spatial dimensions.

[0583] The angular field 124 of the display element 310 is, in general, constrained by the ratio of the beam width to the element width. Reducing the beam width relative to the element width allows for a greater angular field 124, but requires a higher value of N.

[0584] FIG. 34A shows a cross-sectional side elevation of a two-way light field display 300, adapted to oscillate the array of two-way display elements 310 vertically.

[0585] The display 300 consists of a display panel 800, movably attached to a chassis 802. The display panel 800 incorporates the array of two-way display elements 310. A frame 804 is attached to the chassis 802, surrounding the panel 800 and holding a transparent cover glass 806 that protects the panel 800.

[0586] The display panel 800 is movably attached to the chassis 802 via a set springs 808, each attached to a bracket 810 on the back of the panel 800 and a matching bracket 812 on the chassis 802.

[0587] The display panel 800 is moved vertically via an actuator 814 driving a rod 816. The rod is attached to a bracket 818 on the back of the panel 800 and the actuator is attached to a matching bracket 820 on the chassis 802.

[0588] The actuator 814 may be any actuator suitable for displacing the weight of the panel 800 by the desired amount (e.g. 2 mm) at the desired rate (e.g. 100 Hz). For example, it may consist of current-carrying coils acting on magnets embedded in the rod 816 [Petersen82, Hirabayashi95].

[0589] FIG. 34B shows the same cross-sectional side elevation of a two-way light field display 300, but incorporating two contiguous display panels 800 in the vertical dimension rather than just one.

[0590] FIG. 34C and FIG. 34D show the cross-sectional back elevations corresponding to FIG. 34A and FIG. 34B respectively. FIG. 34D shows the display 300 incorporating four contiguous display panels 800, two in each dimension. This illustrates how a larger display 300 can be constructed, in a modular fashion, from multiple smaller panels 800.

[0591] The oscillating display 300 is designed to oscillate its panel(s) 800, within one frame period (i.e. one temporal sampling period 114), between two vertical positions that are a distance of one spatial sampling period 120 apart.

[0592] In one mode of operation the actuator 814 is used to directly determine the vertical offset of the panel 800. The panel 800 is then moved as quickly as possible from one extreme vertical offset to the other, and the next half-frame is displayed (or captured) as soon as the panel 800 is in position. The display duty cycle is then a function of the speed of the actuator. The faster the actuator the higher the duty cycle. This mode is illustrated by the graph of vertical offset versus time in FIG. 35A.

[0593] In an alternative mode of operation the spring constants of the springs 808 are chosen so that they and the panel 800 form a harmonic oscillator with the desired frequency. The actuator 814 is then used to drive the oscillator with the desired amplitude. This requires a less powerful actuator than direct driving, and consumes less power during operation.

[0594] The disadvantage of harmonic oscillation is that the display 800 follows the sinusoidal path shown in FIG. 35B and is therefore only momentarily stationary at the extreme vertical offsets. A compromise then needs to be made between duty cycle and vertical motion blur. The lower the duty cycle the lower the blur, although, beneficially, the blur decreases more rapidly than the duty cycle due to the sinusoid. By way of example, FIG. 35B shows a duty cycle of 67%, corresponding to vertical motion of 50%, i.e. a motion blur diameter of 25%.

[0595] If the oscillation is harmonic and the display element 310 is scanning then the fast scan direction is ideally aligned with the oscillation axis to minimise interaction between the oscillation and the scan.

[0596] The frequency of the harmonic oscillator is proportional to the square root of the ratio of the spring constant of the springs 808 to the mass of the panel 800. Since both spring constants and masses are additive, the frequency is independent of the number of panels 800 used to create the display 300.

[0597] As an alternative to using oscillation to merge two half-frame light fields produced by a single display, the light fields produced by two displays can be combined via a beam combiner (e.g. a half-silvered glass plate).

Real-Time Capture and Display of a Light Field

[0598] In one important use-case, as illustrated in FIG. 11 and FIG. 12 and described above, a light field display 200 receives and displays a light field from a (possibly remote) light field camera 220 in real time.

[0599] As discussed above, how capture focus is managed depends in part on the available focus modulation rate.

[0600] FIG. 36 shows an activity diagram for the display controller 342 and the camera controller 340 cooperatively

controlling focus based on the position of the viewer (and optionally the viewer's gaze direction).

[0601] The display controller 342 periodically detects the face and eyes of the viewer (at 900) (or of each of several viewers), optionally also estimates the viewer's gaze direction (at 902), and transmits (at 904) the positions of the eyes (and optionally the gaze direction) to the camera controller 340.

[0602] The camera controller 340 receives the eye positions (and optionally the gaze direction), and autofocuses accordingly (at 906). Autofocus may rely on explicitly setting focus based on a depth obtained by range-finding (discussed above), or on a traditional autofocus technique such as phase detection between images from adjacent camera elements 230, adaptively adjusting focus to maximise image sharpness in the desired direction, or a combination of the two.

[0603] If the camera controller 340 only receives eye positions then it may infer a pair of possible gaze directions for each camera element 230 based on the positions of the eyes. This implements the position-based viewer-specific focus mode described earlier in relation to FIG. 10B. If the camera controller 340 receives an estimate of the gaze direction then it may use this directly. This implements the gaze-directed viewer-specific focus mode described earlier in relation to FIG. 10C and FIG. 10D.

[0604] If the camera supports per-sample autofocus then this is most naturally based on the per-sample depth 136, and neither the eye positions nor the estimated gaze direction are required. If the camera supports per-frame (or per-sub-frame) focus modulation then autofocus can be based on the estimated or inferred gaze directions.

[0605] As previously discussed, if the positions of the eyes are used to infer possible gaze directions for each camera element 230, then a separate display pass (and hence capture pass) is ideally used for each eye.

[0606] In general, since autofocus may span multiple frames, when there are multiple capture passes (e.g. corresponding to multiple viewers or eyes), autofocus context must be preserved over several frames for each pass.

[0607] FIG. 37 shows an activity diagram for the display controller 342 and the camera controller 340 cooperatively controlling focus based on the fixation point (or fixation depth) of the viewer. This again implements the gaze-directed viewer-specific focus mode described earlier in relation to FIG. 10C and FIG. 10D.

[0608] The display controller 342 periodically detects the face and eyes of the viewer (at 900) (or of each of several viewers), estimates the viewer's fixation point (or depth) (at 908), and transmits (at 910) the positions of the eyes and the fixation point (or depth) to the camera controller 340. The display controller 342 may estimate the fixation point (or depth) based on the viewer's gaze direction in conjunction with the sample depth 136 in the incoming light field video 110, or on the vergence of the user's eyes, or on a combination of the two.

[0609] FIG. 38 shows an activity diagram for camera controller 340 and display controller 342 cooperatively capturing and displaying a sequence of light field frames 116 in real time.

[0610] The camera controller 340 periodically captures a light field frame (at 920) and transmits it (at 922) to the display controller 342. The display controller 342 receives

and optionally resamples the light field frame (at 924), and finally displays the light field frame (at 926). Resampling is discussed further below.

[0611] The resampling step 924 optionally uses a locally-captured light field frame to virtually illuminate the scene represented by the remotely-captured light field frame. This is straightforward via ray tracing (discussed below) if the remotely-captured light field frame 116 contains depth 136.

Display of a Previously-Captured Light Field Video

[0612] In another important use-case, a two-way light field display 300 displays a previously-captured light field video.

[0613] FIG. 39 shows an activity diagram for two-way display controller 322 displaying a light field video 110.

[0614] The diagram shows two parallel activities: a face-detection activity on the left and a display activity on the right.

[0615] The face detection activity periodically detects the face and eyes of the viewer (at 900) (or of each of several viewers), stores the eye positions in a datastore 930, estimates the viewer's fixation point (or depth) (at 908), and stores the fixation point (or depth) in a datastore 932. The controller estimates the fixation point (or depth) based on the viewer's gaze direction in conjunction with the sample depth 136 in the source light field video 110 (stored in a datastore 934), or on the vergence of the user's eyes, or on a combination of the two.

[0616] The display activity periodically displays (at 926) the next light field frame 116 of the light field video 110. It optionally resamples (at 936) the light field prior to display, in particular to match the focus to the estimated fixation plane. This again implements the gaze-directed viewer-specific focus mode described earlier in relation to FIG. 10C and FIG. 10D.

[0617] The display activity optionally captures (at 920) a light field frame 116, allowing the subsequent resampling step (at 936) to use the captured light field frame to virtually illuminate the scene represented by the light field video. This is straightforward via ray tracing (discussed below) if the light field video 110 contains depth 136. It allows real ambient lighting incident on the display 300 to light the scene in the video, and it allows the real objects visible to the two-way display (including the viewer) to be reflected by virtual objects in the virtual scene.

[0618] The two parallel activities are asynchronous and typically have different periods. For example, the face-detection activity may run at 10 Hz while the display activity may run at 100 Hz. The two activities communicate via the shared datastores.

Display of Light Field Video from a 3D Animation Model

[0619] In yet another important use-case, a two-way light field display 300 generates and displays light field video from a 3D animation model.

[0620] FIG. 40 shows an activity diagram for two-way display controller 322 generating and displaying light field video 110 from a 3D animation model.

[0621] The diagram shows two parallel activities: a face-detection activity on the left and a display activity on the right.

[0622] The face detection activity periodically detects the face and eyes of the viewer (at 900) (or of each of several viewers), stores the eye positions in a datastore 930, estimates the viewer's fixation point (or depth) (at 908), and stores the fixation point (or depth) in a datastore 932. The controller estimates the fixation point (or depth) based on the viewer's gaze direction in conjunction with depth information deter-

mined from the 3D animation model (stored in a datastore **938**), or on the vergence of the user's eyes, or on a combination of the two.

[0623] The display activity periodically renders (at **940**) and displays (at **926**) the next light field frame **116** from the 3D animation model. During rendering it matches the focus to the estimated fixation plane. This again implements the gaze-directed viewer-specific focus mode described earlier in relation to FIG. **10C** and FIG. **10D**.

[0624] Rendering a light field frame **116** is straightforward via ray tracing [Levoy96, Levoy00]. As illustrated in FIG. **3B**, each spectral radiance **128** may be generated by tracing, from a corresponding (now virtual) light sensor **152**, a set of rays that sample the sampling beam **166**, and determining the interaction of each ray with the 3D model [Glassner89]. The rays are ideally chosen to sample the 4D sampling beam **166** stochastically, to avoid low-frequency artifacts associated with regular sampling. Ray density may also be matched adaptively to scene complexity to reduce aliasing.

[0625] The two parallel activities are asynchronous and typically have different periods. For example, the face-detection activity may run at 10 Hz while the display activity may run at 100 Hz. The two activities communicate via the shared datastores.

[0626] Although the rendering step **940** is shown performed by the two-way display controller **322**, it may also be performed by a separate computing device in communication with the two-way display controller **322**.

[0627] The display activity optionally captures (at **920**) a light field frame **116**, allowing the subsequent rendering step (at **940**) to use the captured light field frame to virtually illuminate the scene represented by the 3D animation model. This is again straightforward during ray tracing. It allows real ambient lighting incident on the display **300** to light the virtual scene, and it allows the real objects visible to the two-way display (including the viewer) to be reflected by virtual objects in the virtual scene.

[0628] The viewer's gaze can be reflected at each virtual surface it encounters to obtain the actual fixation point **262** (as shown in FIG. **10C**). The fixation point can then either be virtual or real, i.e. behind the display or in front of the display respectively. If the fixation point is virtual then the depth of the fixation point is determined by tracing the gaze, via further reflections (if any), to an element **310**. If the fixation point is virtual then the capture beam is diverging; if real then the capture beam is converging. This allows the viewer to fixate on a real object via a reflection in a virtual object.

[0629] In addition to including light field video **110** captured by the two-way display **300**, the 3D animation model can include already-captured or live light field video from other sources. This includes light field video **110** from another two-way light field display **300** mounted back-to-back with the present two-way light field display **300**, allowing virtual objects to overlay (and refract, when transparent) real objects visible to the back-facing two-way display **300**.

Distribution of Functions

[0630] The functions of the display controller **342** may be performed by a dedicated controller associated with or embedded in the display **200**, or by a separate device (or devices) in communication with the display **200**.

[0631] Likewise, the functions of the camera controller **340** may be performed by a dedicated controller associated with

or embedded in the camera **220**, or by a separate device (or devices) in communication with the camera **220**.

Light Field Resampling

[0632] Prior to display, a light field **110** may need to be resampled. This is necessary if the temporal sampling period **114**, spatial sampling period **120** or angular sampling period **126** of the target display **200** differs from the corresponding sampling period of the source light field **110**; if their respective spectral sampling bases **132** differ; if their respective sampling focuses **138** differ; or if their respective light field boundaries **102** differ, e.g. one is rotated or translated relative to the other, or they have different curved shapes.

[0633] Translation may include translation in the z direction, e.g. to display virtual objects in front of the display.

[0634] In addition to spectral resampling, spectral remapping may be used to map non-visible wavelengths (such as ultraviolet and near infrared) to visible wavelengths.

[0635] Resampling is not required if the captured (or synthesised) light field **110** being displayed matches the characteristics of the target light field display **200**. For example, no resampling is required, by default, when pairs of identical two-way displays **300** are used together, e.g. each displaying the light field **110** captured by the other as shown in FIG. **11**. However, resampling to translate the light field boundary of a light field video **110** to compensate for the spatial separation of a pair of back-to-back displays **300** can be used to implement practical invisibility for the region between the two displays.

[0636] Light field resampling involves generating, from an input light field video **110**, a resampled output light field video **110**. If the temporal sampling regime is unchanged, then it involves generating, from an input light field frame **116**, a resampled output light field frame **116**, i.e. a set of output light field view images **122**, each corresponding to a position (xy) on the spatial sampling grid of the output light field frame **116**. One of the most common uses of light fields is to generate novel 2D views [Levoy96, Levoy00, Isaksen00, Ng05a]. Resampling a light field equates to generating a set of novel 2D views.

[0637] As illustrated in FIG. **3B**, each spectral radiance **128** has a corresponding (virtual) light sensor **152** and sampling beam **166**. Computing a resampled output spectral radiance **128** involves identifying all sampling beams **166** associated with the input light field frame **116** that impinge on the light sensor **152** corresponding to the output spectral radiance, and computing the weighted sum of each beam's corresponding input spectral radiance **128**. Each weight is chosen to be (at least approximately) proportional to the overlap between the beam and the light sensor **152**.

Additional Display Modes

[0638] The primary display mode of the light field display **200** is to reconstruct a continuous light field from a discrete light field **110** representing a scene containing objects at arbitrary depths.

[0639] In addition to this primary display mode it is useful to support a display mode in which the display **200** emulates a conventional 2D display. Given a 2D image, this can be achieved in two ways. In the first approach the 2D source image is simply embedded at a convenient virtual location in 3D, and the corresponding discrete light field is rendered and displayed. In this case the 2D image is limited to lying in front

of or behind the display **200**, subject to the minimum (negative or positive) focal length and angular field **124** of the display elements **210**. The sample count of the 2D source image is then limited by the angular sample count of the display **200**.

[0640] In the second approach the entire light field view image **122** of each display element **210** is set to a constant value equal to the value of the spatially-corresponding pixel in the 2D source image, and the display element focus is set to its minimum (negative or positive). The sample count of the 2D source image is then limited by the spatial sample count of the display **200**.

[0641] It is also useful to support a display mode where the scene is located at infinity. In this case the output of the display **200** is collimated, the view image **122** displayed by each display element **210** is identical, and the output focus is set to infinity. The required sample count of the collimated source image equals the angular sample count of the display **200**.

[0642] A collimated source image can be captured using a light field camera **220** by focusing its camera elements **230** at infinity and either choosing one view image **122** as the collimated image, or, for a superior image, averaging a number of view images **122** from a number of camera elements **230** (and in the limit, from all of the camera elements **230**). The averaged image is superior because it has a better signal-to-noise ratio, and because it better suppresses scene content not located at infinity. This averaging approach represents a specific example of a more general synthetic aperture approach.

Synthetic Aperture

[0643] During capture, the light field view images **122** captured by any number of adjacent camera elements **230** can be averaged to simulate the effect of a larger camera aperture [Wilburn05]. In this process, spectral radiances **128** that correspond to the same virtual point source **224** (as shown in FIG. 8B) are averaged. This may require view image resampling to ensure alignment with the 4D sampling grid of the combined view image.

[0644] The use of a synthetic aperture results in a greater effective exposure, and therefore an improved signal to noise ratio, but shallower depth of field.

Staggered Element Timing

[0645] During capture (and subsequent display), the timing of the frame sync signal used by different camera elements **230** (and display elements **210**) can be stochastically staggered to provide more uniform sampling in the time domain [Wilburn11]. This results in a smoother perception of movement when the light field video **110** is displayed, but with increased motion blur if a synthetic aperture is used.

Mirror Mode

[0646] The two-way light field display **300** can also be configured to act as a mirror, i.e. where the captured light field is re-displayed in real time. Capture and display focus is managed as described above.

[0647] In the simplest mirror mode each two-way element re-displays its own captured view image. This can operate via a sample buffer, a line buffer or a full view image buffer per element.

[0648] Image processing can also be performed on the light field between capture and re-display, e.g. image enhancement, relighting, and spectral remapping.

Audio

[0649] The light field display **200** can be configured to reproduce multiple channels of digital audio associated with a light field video **110** by including digital-to-analog converters (DACs), amplifiers, and electro-acoustic transducers (speakers) mounted along the periphery of (or otherwise in the vicinity of) the display.

[0650] The light field camera **220** can be configured to capture multiple channels of digital audio as part of a light field video **110** by including a set acoustic sensors (microphones) mounted along the periphery (or otherwise in the vicinity of) of the display, and analog-to-digital converters (ADCs). A microphone may also be incorporated in each camera element **230**.

[0651] Each audio channel may be tagged with the physical offset of the microphone used to capture it to allow phased-array processing of the audio [VanVeen88, Tashev08], e.g. for reducing ambient noise or isolating individual remote speakers [Anguera07] (e.g. after selection via gaze).

[0652] Phased-array techniques may also be used to focus the reproduction of a selected audio source (such as a remote speaker) at the local viewer who has selected the source [Mizoguchi04] (e.g. after selection via gaze). This allows multiple viewers to attend to different audio sources with reduced interference.

[0653] A sufficiently dense array of speakers (e.g. with a period of 5 cm or less) may be used to reproduce an acoustic wave field [deVries99, Spors08, Vetterli09], allowing audio to be virtually localised to its various sources, independent of the position of the viewer (i.e. listener). This ensures that aural perception of a displayed scene is consistent with its visual perception. A correspondingly dense array of microphones can be used to capture a real acoustic wave field, and an acoustic wave field is readily synthesized from a 3D animation model containing audio sources.

[0654] The light field video **110** can thus be extended to include a time-varying discrete acoustic wave field, i.e. consisting of a dense array of audio channels.

[0655] A one-dimensional speaker array may be used to reproduce an acoustic wave field in one dimension, e.g. corresponding to the horizontal plane occupied by viewers of the display **200**. A two-dimensional speaker array may be used to reproduce an acoustic wave field in two dimensions.

Two-Way Display Controller Architecture

[0656] FIG. 41 shows a block diagram of the two-way display controller **322**, discussed earlier in relation to FIG. 11 and FIG. 12.

[0657] The display controller **342** should be considered equivalent to the two-way display controller **322** operating in display mode, and vice versa. The camera controller **340** should be considered equivalent to the two-way display controller operating in camera mode, and vice versa.

[0658] The two-way display controller **322** includes a two-way panel controller **950** which coordinates the display and capture functions of a single two-way display panel **800**. When a two-way display **300** incorporates multiple panels **800** they can be controlled in modular fashion by multiple panel controllers **950**.

[0659] The display and capture functions of each individual two-way display element 310 is controlled by a corresponding two-way element controller 952. The element controller 952 utilises a view image datastore 954, which holds an output view image 502 for display and a captured input view image 602 (as described earlier in relation to FIG. 15, FIG. 17 and FIG. 18).

[0660] During display, the display element 310 reads successive radiance samples 134 from the output view image 502, while at the same time the panel controller 950 writes new radiance samples 134 to the output view image 502. The view image datastore 954 only needs to accommodate a fractional output view image 502 if reading and writing are well synchronised.

[0661] During capture, the panel controller 950 reads successive radiance samples 134 from the input view image 602, while at the same time the display element 310 writes new radiance samples 134 to the input view image 602. The view image datastore 954 only needs to accommodate a fractional input view image 602 if reading and writing are well synchronised.

[0662] For the illustrative display configuration, the display has a total memory requirement of 6E11 bytes (600 GB) each for display and capture, assuming full (rather than fractional) view images.

[0663] The element controller 952 supports two display modes: standard light field display (from the output view image 502 in the view image datastore 954), and constant-color display (from a constant-color register).

[0664] The two-way display element controller block 956, consisting of the two-way element controller 952 and its view image datastore 954, is replicated for each two-way display element 310.

[0665] The panel controller 950 and/or element controllers 952 may be configured to perform light field decompression prior to or during display and light field compression during or after capture. Light field interchange formats and compression are discussed further below.

[0666] Each of the panel controller 950 and element controllers 952 may comprise one or more general-purpose programmable processing units with associated instruction and data memory, one or more graphics processing units with associated instruction and data memory [Moreton05], and purpose-specific logic such as audio processing, image/video processing and compression/decompression logic [Hamadani98], all with sufficient processing power and throughput to support a particular two-way display configuration.

[0667] Although FIG. 41 shows one element controller 952 per display element 310, an element controller 952 may be configured to control multiple display elements 310.

[0668] The panel controller 950 utilises a 2D image datastore 958 to hold a 2D image for display. As described earlier, the 2D image may be displayed by configuring each display element 310 to display a constant color. In this mode the panel controller 950 writes each pixel of the 2D image to the constant-color register of the corresponding element controller 952. Alternatively, the 2D image may be displayed by synthesising a light field frame 116. In this mode the panel controller 950 synthesises a light frame 116, using a specified 3D location and orientation for the 2D image, and writes each resultant output view image 122 to its corresponding view image datastore 954.

[0669] The panel controller 950 utilises a collimated view image datastore 960 when operating in collimated mode,

holding a collimated output view image and a collimated input view image. As described earlier, in collimated display mode each display element 310 displays the same output view image 122. The panel controller 950 can either broadcast the collimated output view image to the element controllers 952 during display, or the collimated output view image can be written to the individual view image datastores 954 prior to display.

[0670] As also described earlier, in collimated capture mode the collimated output view image may be obtained by averaging a number of input view images 602. The panel controller 950 can perform this averaging during or after capture.

[0671] A network interface 962 allows the panel controller 950 to exchange configuration data and light field video 110 with external devices, and may comprise a number of conventional network interfaces to provide the necessary throughput to support light field video 110. For example, it may comprise multiple 10 Gbps or 100 Gbps Gigabit Ethernet (GbE) interfaces, coupled to fiber or wire.

[0672] An input video interface 964 allows an external device to write standard-format video to the display 300 for 2D display via the 2D datastore 958, allowing the display 300 to be used as a conventional 2D display.

[0673] When the display 300 is operating in collimated display mode, the input video interface 964 also allows an external device to write collimated light field video 110 as standard-format video to the display for display via the collimated view image datastore 960.

[0674] When the display 300 is operating in collimated capture mode, an output video interface 966 allows other devices to read collimated light field video 110 from the display as standard-format video. This allows collimated light field video 110 to be easily exchanged between a pair of two-way light field displays 300 using a pair of standard video interconnections.

[0675] A display timing generator 968 generates the global frame sync signal 512 used to control both display and capture (as described in relation to FIG. 15 and FIG. 17 respectively).

[0676] If the display is designed to oscillate, as described in relation to FIGS. 24A through 24D, a panel motion controller 970 drives the actuator 814 and monitors the position of the piston 816.

[0677] The various components of the two-way display controller 322 communicate via a high-speed data bus 972. Although various data transfers are described above as being performed by the panel controller 950, in practice they may be initiated by the panel controller (or other components) but performed by DMA logic (not shown). The data bus 972 may comprise multiple buses.

[0678] Although the various datastores are shown as distinct, they may be implemented as fixed-size or variable-size regions of one or more memory arrays.

Light Field Interchange Formats and Compression

[0679] While light field video 110 may be exchanged between compatible devices (including light field cameras 220, light field displays 200, and other devices) in uncompressed form, the throughput (and memory) requirements of light field video typically motivate the use of compression. The illustrative display configuration has a throughput of 4E13 samples/s (5E14 bits/s; 500x100 GbE links), and requires a frame memory of 6E11 bytes (600 GB).

[0680] Compression may exploit the full 5D redundancy within time intervals of a light field video **110** (i.e. including inter-view redundancy [Chang06]), or 4D redundancy within a light field frame **116** [Levoy96, Levoy00, Girod03]. It may also utilise conventional image or video compression techniques on each (time-varying) light field view image **122**, such as embodied in the various JPEG and MPEG standards. 100:1 compression based on 4D redundancy is typical [Levoy96, Levoy00].

[0681] Stereoscopic and multiview video utilised by 3DTV and video (3DV) systems contains a small number of sparse views, and H.264/MPEG-4 (via its multiview video coding (MVC) profiles) supports 5D compression with the addition of inter-view prediction to the usual spatial and temporal prediction of traditional single-view video [Vetro11]. MVC 5D compression can be applied to a dense light field video **110**.

[0682] When the optional light field depth **136** is available, depth-based compression techniques can be used. Depth-based representations used in 3DV systems include multiview video plus depth (MVD), surface-based geometric representations (e.g. textured meshes), and volumetric representations (e.g. point clouds) [Alatan07, Muller11].

[0683] With MVD, the use of depth information allows effective inter-view prediction from a sparser set of views than standard inter-view prediction (i.e. MVC without depth), thus MVD allows a dense set of views to be more effectively synthesized from a sparse set of views, thus at least partly decoupling the view density of the interchange format from the view density of the display [Muller11].

[0684] By supporting 3DV formats the display **300** also becomes capable of exchanging 3D video streams with other 3DV devices and systems.

Visibility-Based Two-Way Display Controller Architecture

[0685] As shown in FIG. 42A, each two-way display element **310** has an angular field **980** (corresponding to the light field angular field **124**), only a small subset **982** of which is seen by the eye **240** of a viewer.

[0686] It is therefore efficient to only capture, transmit, resample, render and display the subset **982** of each element's field (suitably expanded to allow for eye movement between frames), as this reduces the required communication and processing bandwidth, as well as the required power. This selective capture, processing and display relies on face detection.

[0687] If the two-way display element **310** is a scanning element, then the scanning time in one or both scanning directions can be reduced if the scan is limited to the visible field **982**.

[0688] Assuming a minimum viewing distance of 200 mm and a visible field **982** 10 mm wide at the eye, the (one-way) throughput of the illustrative display configuration (per viewer) is reduced by two orders of magnitude to 4E11 samples/s (5E12 bits/s; 46x100 GbE links uncompressed; 1x100 GbE link with 46:1 compression), and the memory requirements to 6E9 bytes (6 GB).

[0689] As further shown in FIG. 42B, only a small number of display elements **210** intersect a projection **984** of the foveal region of the retina of the eye **240**. It is therefore efficient to capture, transmit, resample, render and display the light field using a reduced angular sampling rate outside this region (suitably expanded to allow for eye movement between frames). This selective capture, processing and display relies on gaze estimation.

[0690] FIG. 43 shows a block diagram of the two-way display controller **322** optimised for visibility-based display and capture.

[0691] Each full-field view image **122** (stored in the view image datastore **954** of FIG. 41) is replaced by a smaller partial view image **122** (stored in the partial view image datastore **986** in FIG. 43). Each partial view image only covers the corresponding element's eye-specific partial angular field **982** (shown in FIG. 41A).

[0692] The maximum required size of a partial view image is a function of the minimum supported viewing distance.

[0693] If the display **300** supports multiple viewers in viewer-specific mode (e.g. via multiple display passes), then the capacity of the partial view image datastore **986** can be increased accordingly. At a minimum, to support a single viewer during display and a single viewer during capture, the partial view image datastore **986** has a capacity of four partial view images, i.e. one per viewer eye **240**.

[0694] Further, as discussed above in relation to FIG. 42B, each partial view image may be subsampled, and then replaced by a non-subsampled partial view image when the corresponding display element **310** falls within the projection of the fovea. This can allow a further order of magnitude reduction in the size of each partial view image. In this approach a number of non-subsampled partial view images are stored in a partial foveal view image datastore **988**, and each display element **310** within the projection of the fovea is configured to use a designated partial foveal view image (in the datastore **988**) in place of its own subsampled partial view image (in the datastore **986**).

[0695] The maximum required number of foveal view images is a function of the maximum viewing distance at which foveal display is supported.

[0696] Assuming a maximum viewing distance of 5000 mm for foveal viewing, and a foveal field **984** of 2 degrees, the (one-way) throughput of the illustrative display configuration (per viewer) is reduced by a further factor of six to 7E10 samples/s (8E11 bits/s; 8x100 GbE links uncompressed; 1x100 GbE link with 8:1 compression; 1x10 GbE link with 80:1 compression), and the memory requirements to 1E9 bytes (1 GB).

[0697] When the foveal regions of multiple viewers are non-overlapping, it is possible to support viewer-specific focus within each viewer's foveal region during a single display pass.

[0698] Visibility-based capture works in the same way, with the distinction that while visibility-based display is responsive to the position or gaze of one or more local viewers of the display, visibility-based capture is responsive to the position or gaze of one or more viewers viewing the captured light field on a remote display.

[0699] With visibility-based subsampling the element controller **952** supports two additional display modes: display with interpolation of radiance samples **134** (from the subsampled output view image in the partial view image datastore **986**), and foveal display (from the designated partial foveal output view image in the partial foveal image datastore **988**).

REFERENCES

[0700] The contents of the following publications, referred to within this specification, are herein incorporated by reference.

- [0701] [Anguera07] X. Anguera et al, "Acoustic Beamforming for Speaker Diarization of Meetings", IEEE Transactions on Audio, Speech, and Language Processing, 15(7), September 2007
- [0702] [Alatan07] A. A. Alatan et al, "Scene Representation Technologies for 3DTV—A Survey", IEEE Transactions on Circuits and Systems for Video Technology, 17(11), November 2007
- [0703] [Amir03] A. Amir et al, "Calibration-Free Eye Gaze Tracking", U.S. Pat. No. 6,578,962, Jun. 17, 2003
- [0704] [Aziz10] H. Aziz and J. A. Coggan, "Stacked OLED Structure", U.S. Pat. No. 7,750,561, Jul. 6, 2010
- [0705] [Adelson91] E. H. Adelson and J. R. Bergen, "The Plenoptic Function and the Elements of Early Vision", Computational Models of Visual Processing, M. Landy and J. A. Movshon (eds), MIT Press, 1991, pp. 3-20
- [0706] [Balogh06] T. Balogh, "Method and Apparatus for Displaying 3D Images", U.S. Pat. No. 6,999,071, Feb. 14, 2006
- [0707] [Barabas11] J. Barabas et al, "Diffraction Specific Coherent Panoramagrams of Real Scenes", Proceedings of SPIE, Vol 7957, 2011
- [0708] [Benzie07] P. Benzie et al, "A Survey of 3DTV Displays: Techniques and Technologies", IEEE Transactions on Circuits and Systems for Video Technology, 17(11), November 2007
- [0709] [Berge07] B. Berge and J. Peseux, "Lens with Variable Focus", U.S. Pat. No. RE39,874, Oct. 9, 2007
- [0710] [Bernstein02] J. Bernstein, "Multi-Axis Magnetically Actuated Device", U.S. Pat. No. 6,388,789, May 14, 2002
- [0711] [Berreman80] D. W. Berreman, "Variable Focus Liquid Crystal Lens System", U.S. Pat. No. 4,190,330, Feb. 26, 1980
- [0712] [Betke00] M. Betke et al, "Active Detection of Eye Scleras in Real Time", IEEE CVPR Workshop on Human Modeling, Analysis and Synthesis, 2000
- [0713] [Brill98] M. H. Brill et al, "Prime Colors and Color Imaging", The Sixth Color Imaging Conference Color Science, Systems and Applications, Nov. 17-20, 1998, IS&T
- [0714] [Bright00] W. J. Bright, "Pipeline Analog-to-Digital Conversion System Using Double Sampling and Method of Operation", U.S. Pat. No. 6,166,675, Dec. 26, 2000
- [0715] [Champion12] M. Champion et al, "Scanning Mirror Position Determination", U.S. Pat. No. 8,173,947, May 8, 2012
- [0716] [Chang96] I-C. Chang, "Acousto-Optic Bragg Cell", U.S. Pat. No. 5,576,880, Nov. 19, 1996
- [0717] [Chang06] C-L. Chang et al, "Light Field Compression Using Disparity-Compensated Lifting and Shape Adaptation", IEEE Transactions on Image Processing, 15(4), April 2006
- [0718] [Connor11] R. A. Connor, "HoloVision™ 3D Imaging with Rotating Light-Emitting Members", U.S. Pat. No. 7,978,407, Jul. 12, 2011
- [0719] [deVries99] D. de Vries and M. M. Boone, "Wave Field Synthesis and Analysis Using Array Technology", Proceedings of the 1999 IEEE Workshop on Applications of Signal Processing to Audio and Acoustics, 17-20 Oct. 1999
- [0720] [DiCarlo06] A. DiCarlo et al, "Yokeless Hidden Hinge Digital Micromirror Device", U.S. Pat. No. 7,011,415, Mar. 14, 2006
- [0721] [Duchowski07] A. T. Duchowski, Eye Tracking Methodology—Theory and Practice, Second Edition, Springer 2007
- [0722] [Fossum04] E. R. Fossum et al, "Active Pixel Sensor with Intra-Pixel Charge Transfer", U.S. Pat. No. 6,744,068, Jun. 1, 2004
- [0723] [Fang08] J. Fang et al, "Wide-Angle Variable Focal Length Lens System", U.S. Pat. No. 7,359,124, Apr. 15, 2008
- [0724] [Georgiev06] T. Georgiev et al, "Spatio-Angular Resolution Tradeoff in Integral Photography", Eurographics Symposium on Rendering, 2006
- [0725] [Georgiev09] T. Georgiev et al, "Plenoptic Camera", U.S. Pat. No. 7,620,309, Nov. 17, 2009
- [0726] [Gerhard00] G. J. Gerhard et al, "Scanned Display with Pinch, Timing and Distortion Correction", U.S. Pat. No. 6,140,979, Oct. 31, 2000
- [0727] [Girod03] B. Girod et al, "Light Field Compression Using Disparity-Compensated Lifting", 2003 IEEE International Conference on Multimedia and Expo, July 2003
- [0728] [Glassner89] A. S. Glassner (ed.), An Introduction to Ray Tracing, Academic Press, 1989
- [0729] [Hamadani98] M. Hamadani and R-S. Kao, "MPEG Encoding and Decoding System for Multimedia Applications", U.S. Pat. No. 5,845,083, Dec. 1, 1998
- [0730] [Hansen10] D. W. Hansen and Q. Ji, "In the Eye of the Beholder: A Survey of Models for Eyes and Gaze", IEEE Transactions on Pattern Analysis and Machine Intelligence, 32(3), March 2010
- [0731] [Hartridge22] H. Hartridge, "Visual Acuity and the Resolving Power of the Eye", The Journal of Physiology, 57(1-2), Dec. 22, 1922
- [0732] [Higuchi10] Y. Higuchi and K. Omae, "Method of Manufacturing Nitride Semiconductor Light Emitting Element and Nitride Semiconductor Light Emitting Element", US Patent Application Publication No. 2010/0098127, Apr. 22, 2010
- [0733] [Hirabayashi95] Y. Hirabayashi et al, "Moving Magnet-Type Actuator", U.S. Pat. No. 5,434,549, Jul. 18, 1995
- [0734] [Hoffman08] D. M. Hoffman et al, "Vergence-Accommodation Conflicts Hinder Visual Performance and Cause Visual Fatigue", Journal of Vision, 8(3):33, 28 Mar. 2008
- [0735] [Hornbeck96] L. J. Hornbeck, "Active Yoke Hidden Hinge Digital Micromirror Device", U.S. Pat. No. 5,535,047, Jul. 9, 1996
- [0736] [Hua11] G. Hua et al, "Face Recognition Using Discriminatively Trained Orthogonal Tensor Projections", U.S. Pat. No. 7,936,906, May 3, 2011
- [0737] [Imai11] T. Imai et al, "Variable-Focal Length Lens", U.S. Pat. No. 8,014,061, Sep. 6, 2011
- [0738] [Isaksen00] A. Isaksen et al, "Dynamically Reparameterized Light Fields", Proceedings of the 27th Annual Conference on Computer Graphics and Interactive Techniques, ACM, 2000
- [0739] [Jacob07] S. A. Jacob, "Variable Focal Length Electro-Optic Lens", US Patent Application Publication No. 2007/0070491, Mar. 29, 2007
- [0740] [Jones03] M. J. Jones and P. Viola, "Fast Multi-View Face Detection", Mitsubishi Electric Research Laboratories TR2003-96, August 2003

- [0741] [Jones06] M. J. Jones and P. Viola, "Method and System for Object Detection in Digital Images", U.S. Pat. No. 7,099,510, Aug. 29, 2006
- [0742] [Kasahara11] D. Kasahara et al, "Demonstration of Blue and Green GaN-Based Vertical-Cavity Surface-Emitting Lasers by Current Injection at Room Temperature", *Applied Physics Express*, 4(7), July 2011
- [0743] [Kolb09] A. Kolb et al, "Time-of-Flight Sensors in Computer Graphics", *Eurographics Conference 2009*
- [0744] [Kobayashi91] K. Kobayashi, "Laser Beam Scanning System", U.S. Pat. No. 4,992,858, Feb. 12, 1991
- [0745] [Koike08] T. Koike et al, "Three-Dimensional Display Device", US Patent Application Publication No. 2008/0036759, Feb. 14, 2008
- [0746] [Kowel86] G. T. Kowel et al, "Adaptive Liquid Crystal Lens", U.S. Pat. No. 4,572,616, Feb. 25, 1986
- [0747] [Lazaros08] N. Lazaros et al, "Review of Stereo Vision Algorithms: from Software to Hardware", *International Journal of Optomechatronics*, 2, 2008
- [0748] [Levinson96] R. A. Levinson and S. T. Ngo, "Pipelined Analog to Digital Converter", U.S. Pat. No. 5,572,212, Nov. 5, 1996
- [0749] [Levoy96] M. Levoy and P. Hanrahan, "Light Field Rendering", *Proceedings of the 23rd Annual Conference on Computer Graphics and Interactive Techniques*, ACM, 1996
- [0750] [Levoy00] M. Levoy and P. Hanrahan, "Method and System for Light Field Rendering", U.S. Pat. No. 6,097,394, Aug. 1, 2000
- [0751] [Lin11] H-C. Lin et al, "A Review of Electrically Tunable Focusing Liquid Crystal Lenses", *Transactions on Electrical and Electronic Materials*, 12(6), 25 Dec. 2011
- [0752] [Lienhart03] R. Lienhart et al, "A Detector Tree of Boosted Classifiers for Real-Time Object Detection and Tracking", *Proceedings of the 2003 International Conference on Multimedia and Expo—Volume 1*, 2003
- [0753] [Love09] G. D. Love et al, "High-Speed Switchable Lens Enables the Development of a Volumetric Stereoscopic Display", *Optics Express* 17(18), 31 Aug. 2009
- [0754] [Lu09] T-C. Lu et al, "Development of GaN-Based Vertical cavity Surface-Emitting Lasers", *IEEE Journal of Selected Topics in Quantum Electronics*, 15(3), May/June 2009
- [0755] [Maserjian89] J. Maserjian, "Multiple Quantum Well Optical Modulator", U.S. Pat. No. 4,818,079, Apr. 4, 1989
- [0756] [Melville97] C. D. Melville, "Position Detection of Mechanical Resonant Scanner Mirror", U.S. Pat. No. 5,694,237
- [0757] [Merrill05] R. B. Merrill and R. A. Martin, "Vertical Color Filter Sensor Group and Semiconductor Integrated Circuit Fabrication Method for Fabricating Same", U.S. Pat. No. 6,894,265, May 17, 2005
- [0758] [Mizoguchi04] H. Mizoguchi et al, "Visually Steerable Sound Beam Forming System Based On Face Tracking and Speaker Array", *Proceedings of the 17th International Conference on Pattern Recognition*, 23-26 Aug. 2004
- [0759] [Moreton05] H. P. Moreton et al, "User Programmable Geometry Engine", U.S. Pat. No. 6,900,810, May 31, 2005
- [0760] [Muller11] K. Muller et al, "3-D Video Representation using Depth Maps", *Proceedings of the IEEE*, 99(4), April 2011
- [0761] [Naganuma09] K. Naganuma et al, "High-Resolution KTN Optical Beam Scanner", *NTT Technical Review* 7(12), 12 Dec. 2009
- [0762] [Nakamura10] K. Nakamura et al, "Electrooptic Device", U.S. Pat. No. 7,764,302, Jul. 27, 2010
- [0763] [Naumov99] A. F. Naumov et al, "Control Optimization of Spherical Modal Liquid Crystal Lenses", *Optics Express* 4(9), April 1999
- [0764] [Neukermans97] A. P. Neukermans and T. G. Slater, "Micromachined Torsional Scanner", U.S. Pat. No. 5,629,790, May 13, 1997
- [0765] [Ng05a] R. Ng et al, "Light Field Photography with a Hand-held Plenoptic Camera", *Stanford Tech Report CTSR 2005-02*, 2005
- [0766] [Ng05b] R. Ng, "Fourier Slice Photography", *ACM Transactions on Graphics*, 24(3), July 2005
- [0767] [Nishio09] M. Nishio and K. Murakami, "Deformable Mirror", U.S. Pat. No. 7,474,455, Jan. 6, 2009
- [0768] [Oggier11] T. Oggier et al, "On-Chip Time-Based Digital Conversion of Pixel Outputs", U.S. Pat. No. 7,889,257, Feb. 15, 2011
- [0769] [Ong93] E. Ong et al, "Static Accommodation in Congenital Nystagmus", *Investigative Ophthalmology & Visual Science*, 34(1), January 1993
- [0770] [Palmer99] S. E. Palmer, *Vision Science—Photons to Phenomenology*, MIT Press, 1999
- [0771] [Patel78] M. P. Patel, "Bucket Brigade Circuit", U.S. Pat. No. 4,130,766, Dec. 19, 1978
- [0772] [Petersen82] C. C. Petersen, "Linear Motor", U.S. Pat. No. 4,363,980, Dec. 14, 1982
- [0773] [Plainis05] S. Plainis et al, "The Effect of Ocular Aberrations on Steady-State Errors of Accommodative Response", *Journal of Vision*, 5(5):7, 23 May 2005
- [0774] [Qi05] J. Qi et al, "Tailored Elliptical Holographic Diffusers for LCD Applications", *Journal of the SID*, 13(9), 2005
- [0775] [Saleh07] B. E. A. Saleh and M. C. Teich, *Fundamentals of Photonics (Second Edition)*, Wiley, 2007
- [0776] [Sangster77] F. L. J. Sangster, "Charge Transfer Device", U.S. Pat. No. 4,001,862, Jan. 4, 1977
- [0777] [Schwerdtner06] A. Schwerdtner et al, "Device for Holographic Reconstruction of Three-Dimensional Scenes", US Patent Application Publication No. 2006/0250671, Nov. 9, 2006
- [0778] [Seitz06] S. M. Seitz et al, "A Comparison and Evaluation of Multi-View Stereo Reconstruction Algorithms", *IEEE Computer Society Conference on Computer Vision and Pattern Recognition*, 17-22 Jun. 2006
- [0779] [Shechter02] R. Shechter et al, "Compact Beam Expander with Linear Gratings", *Applied Optics* 41(7), 1 Mar. 2002
- [0780] [Sharp00] G. D. Sharp, "Switchable Achromatic Polarization Rotator", U.S. Pat. No. 6,097,461, Aug. 1, 2000
- [0781] [Shibaguchi92] T. Shibaguchi, "Electrooptic Device", U.S. Pat. No. 5,140,454, Aug. 18, 1992
- [0782] [Shih00] S-W. Shih and J. Liu, "A Calibration-Free Gaze Tracking Technique", *Proceedings of the 15th International Conference on Pattern Recognition*, 3-7 Sep. 2000
- [0783] [Simmonds11] M. D. Simmonds and R. K. Howard, "Projection Display", U.S. Pat. No. 7,907,342, Mar. 15, 2011

- [0784] [Spors08] S. Spors et al, "The Theory of Wave Field Synthesis Revisited", 124th Convention of the Audio Engineering Society, 17-20 May 2008
- [0785] [Svelto10] O. Svelto, Principles of Lasers (Fifth Edition), Springer, 2010
- [0786] [Szeliski99] R. S. Szeliski and P. Gotland, "Method for Performing Stereo Matching to Recover Depths, Colors and Opacities of Surface Elements", U.S. Pat. No. 5,917,937, Jun. 29, 1999
- [0787] [Tashev08] I. Tashev and H. Malvar, "System and Method for Beamforming Using a Microphone Array", U.S. Pat. No. 7,415,117, Aug. 19, 2008
- [0788] [Titus99] C. M. Titus et al, "Efficient, Accurate Liquid Crystal Digital Light Deflector", Proc. SPIE Vol. 3633, Diffractive and Holographic Technologies, Systems, and Spatial Light Modulators VI, June 1999
- [0789] [Tompsett78] M. F. Tompsett, "Charge Transfer Imaging Devices", U.S. Pat. No. 4,085,456, Apr. 18, 1978
- [0790] [Turk92] M. Turk and A. P. Pentland, "Face Recognition System", U.S. Pat. No. 5,164,992, Nov. 17, 1992
- [0791] [Turner05] A. M. Turner et al, "Pulse Drive of Resonant MEMS Devices", U.S. Pat. No. 6,965,177, Nov. 15, 2005
- [0792] [Urey11] H. Urey and M. Sayinta, "Apparatus for Displaying 3D Images", US Patent Application Publication No. 2011/0001804, Jan. 6, 2011
- [0793] [Vallese70] L. M. Vallese, "Light Scanning Device", U.S. Pat. No. 3,502,879, Mar. 24, 1970
- [0794] [VanVeen88] B. D. Van Veen and K. M. Buckley, "Beamforming: A Versatile Approach to Spatial Filtering", IEEE ASSP Magazine, April 1988
- [0795] [Vetro11] A. Vetro et al, "Overview of the Stereo and Multiview Video Coding Extensions of the H.264/MPEG-4 AVC Standard", Proceedings of the IEEE, 99(4), April 2011
- [0796] [Vetterli09] M. Vetterli and F. P. C. Pinto, "Audio Wave Field Encoding", US Patent Application Publication No. 2009/0248425, Oct. 1, 2009
- [0797] [vonGunten97] M. K. von Gunten and P. Bevis, "Broad Band Polarizing Beam Splitter", U.S. Pat. No. 5,625,491, Apr. 29, 1997
- [0798] [Watanabe96] M. Watanabe, "Minimal Operator Set for Passive Depth from Defocus", Proceedings of the IEEE Computer Society Conference on Computer Vision and Pattern Recognition, 18-20 Jun. 1996
- [0799] [Wilburn05] B. Wilburn et al, "High Performance Imaging Using Large Camera Arrays", ACM Transactions on Graphics—Proceedings of ACM SIGGRAPH 2005
- [0800] [Wilburn11] B. Wilburn et al, "Apparatus and Method for Capturing a Scene Using Staggered Triggering of Dense Camera Arrays", U.S. Pat. No. 8,027,531, Sep. 27, 2011
- [0801] [Xiaobo10] C. Xiaobo et al, "A 12 bit 100 MS/s pipelined analog to digital converter without calibration", Journal of Semiconductors 31(11), November 2010
- [0802] [Yan06] J. Yan et al, "MEMS Scanner with Dual Magnetic and Capacitive Drive", U.S. Pat. No. 7,071,594, Jul. 4, 2006
- [0803] [Yaras10] F. Yaras et al, "State of the Art in Holographic Displays", Journal of Display Technology, 6(10), October 2010

1. A light field display device comprising an array of light field display elements, each display element comprising:

- (a) a beam generator for generating an output beam of light;
- (b) a radiance modulator for modulating the radiance of the beam over time;
- (c) a focus modulator for modulating the focus of the beam over time; and
- (d) a scanner for scanning the beam across a two-dimensional angular field, the scanner comprising a biaxial electromechanical scanning mirror comprising: a mirror, a platform, an inner frame, and an outer frame; the mirror attached to the platform via a post, the platform attached to the inner frame via a first pair of hinges, and the inner frame attached to the outer frame via a second pair of hinges; the first pair of hinges arranged substantially orthogonally to the second pair of hinges, thereby to allow biaxial movement of the mirror; the extent of the mirror larger than the extent of the inner frame.

2. The device of claim 1, wherein the beam generator comprises at least one light emitter selected from the group comprising: a laser; a laser diode; a light-emitting diode; a fluorescent lamp; and an incandescent lamp.

3. The device of claim 1, wherein the beam generator comprises multiple light emitters with different emission spectra, the light emitters selected from the group comprising: a laser; a laser diode; a light-emitting diode; a fluorescent lamp; and an incandescent lamp.

4. The device of claim 1, wherein the radiance modulator is intrinsic to the beam generator.

5. The device of claim 1, wherein the radiance modulator is selected from the group comprising: an acousto-optic modulator; an absorptive electro-optic modulator; and a refractive electro-optic modulator.

6. The device of claim 1, wherein the focus modulator is selected from the group comprising: a liquid crystal lens; a liquid lens; a deformable membrane mirror; a deformable-membrane liquid-filled lens; an addressable lens stack; and an electro-optic lens.

7. The device of claim 1, wherein the scanner comprises at least one drive mechanism selected from the group comprising: an electrostatic drive mechanism; a magnetic drive mechanism; and a capacitive drive mechanism.

8. The device of claim 1, wherein the platform of the scanner comprises a coil for conducting an alternating current and the scanner further comprises a magnet, such that the time-varying magnetic field of the coil interacts with the field of the magnet to produce a time-varying torque on the platform.

9. The device of claim 1, wherein the inner frame of the scanner comprises a coil for conducting an alternating current and the scanner further comprises a magnet, such that the time-varying magnetic field of the coil interacts with the field of the magnet to produce a time-varying torque on the inner frame.

10. The device of claim 1, further comprising at least one actuator for oscillating the display surface between at least two positions.

11. The device of claim 10, wherein the oscillation is resonant.

12. The device of claim 1, wherein the scanner is further configured to scan an input beam across the two-dimensional angular field, each display element further comprising:

- (f) an input focus modulator for modulating the focus of the input beam;
- (g) a radiance sensor for sensing the radiance of the input beam; and
- (h) a radiance sampler for sampling the radiance of the input beam.

* * * * *