



US 20100094388A1

(19) **United States**
(12) **Patent Application Publication**
Hauge et al.

(10) **Pub. No.: US 2010/0094388 A1**
(43) **Pub. Date: Apr. 15, 2010**

(54) **HALIBUT RELEASE LINER FOR A DEFIBRILLATOR ELECTRODE PAD**

Related U.S. Application Data

(75) Inventors: **Patrick Hauge**, Bellevue, WA (US); **Daniel Powers**, Issaquah, WA (US); **Eric Jonsen**, Seattle, WA (US)

(60) Provisional application No. 60/865,482, filed on Nov. 13, 2006.

Publication Classification

Correspondence Address:
PHILIPS INTELLECTUAL PROPERTY & STANDARDS
P.O. BOX 3001
Briarcliff Manor, NY 10510-8001 (US)

(51) **Int. Cl.**
A61N 1/04 (2006.01)
B31F 1/00 (2006.01)

(52) **U.S. Cl.** **607/142; 493/379**

(73) Assignee: **KONINKLIJKE PHILIPS ELECTRONICS N.V.**, Eindhoven (NL)

(57) **ABSTRACT**

(21) Appl. No.: **12/513,685**
(22) PCT Filed: **Nov. 6, 2007**
(86) PCT No.: **PCT/IB2007/054498**

A release liner for electrode pads is described which enables the pads to be used with defibrillators requiring the electrodes to be electrically interconnected for self-test prior to use, and with defibrillators which do not require the electrodes to be electrically interconnected. In one example this variation is afforded by folding the release liner one way to electrically connect conductive layers underlying two attached electrodes. In another example this variation is afforded by leaving the conductive layers electrically connected or breaking the connection.

§ 371 (c)(1),
(2), (4) Date: **Dec. 28, 2009**

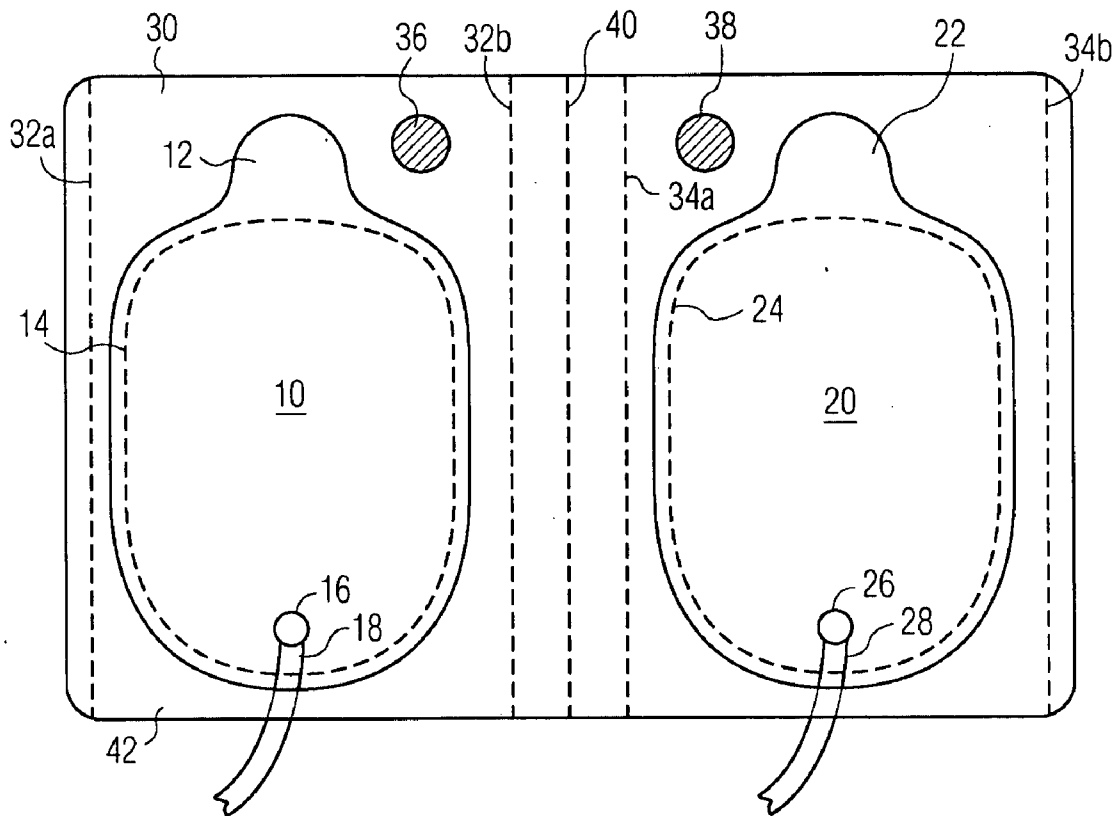

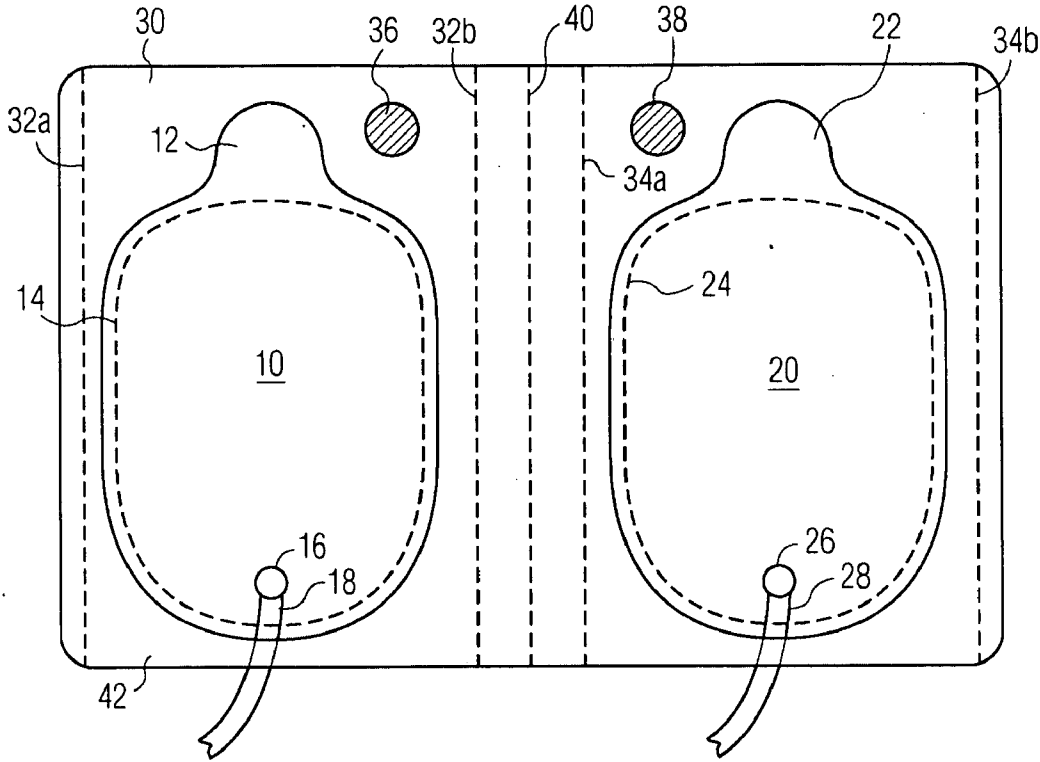
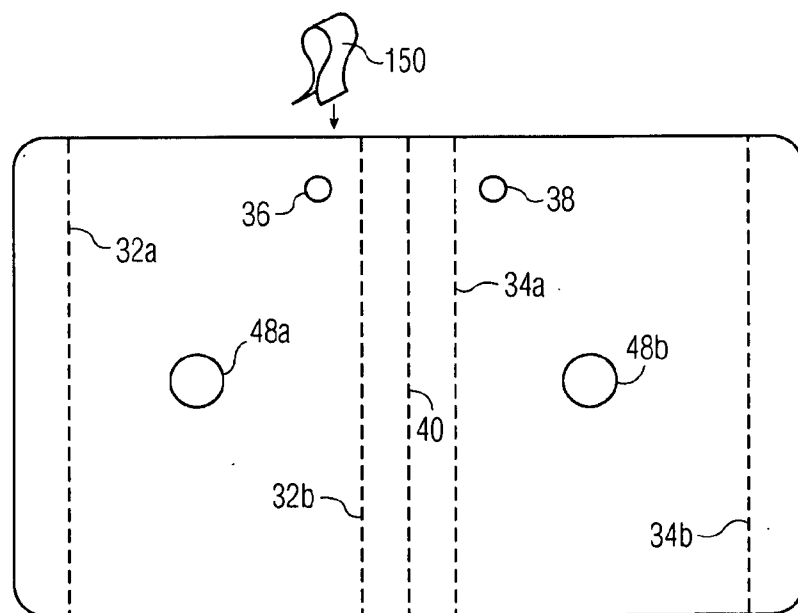
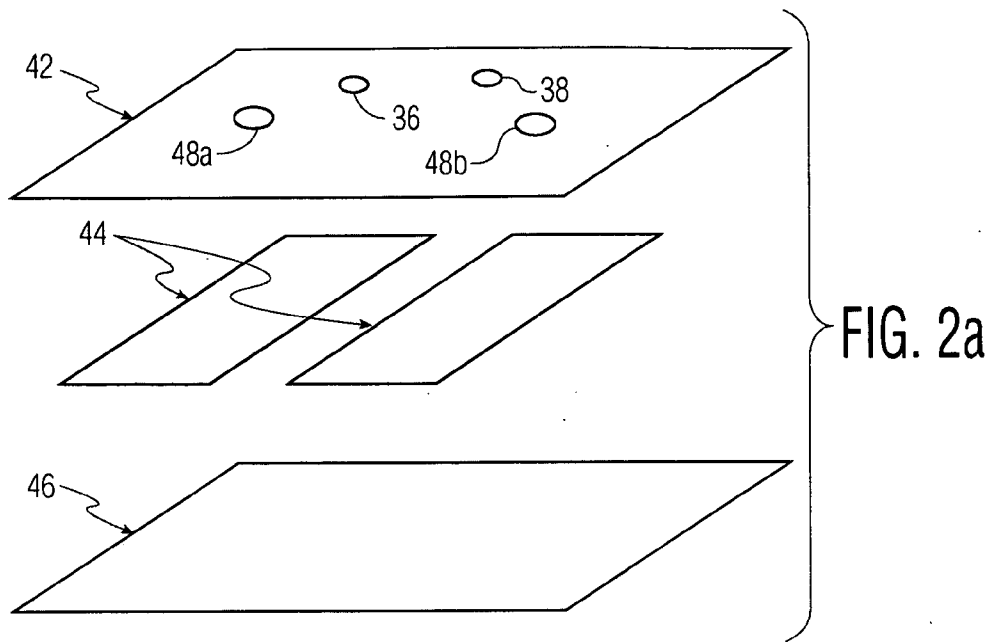

FIG. 1



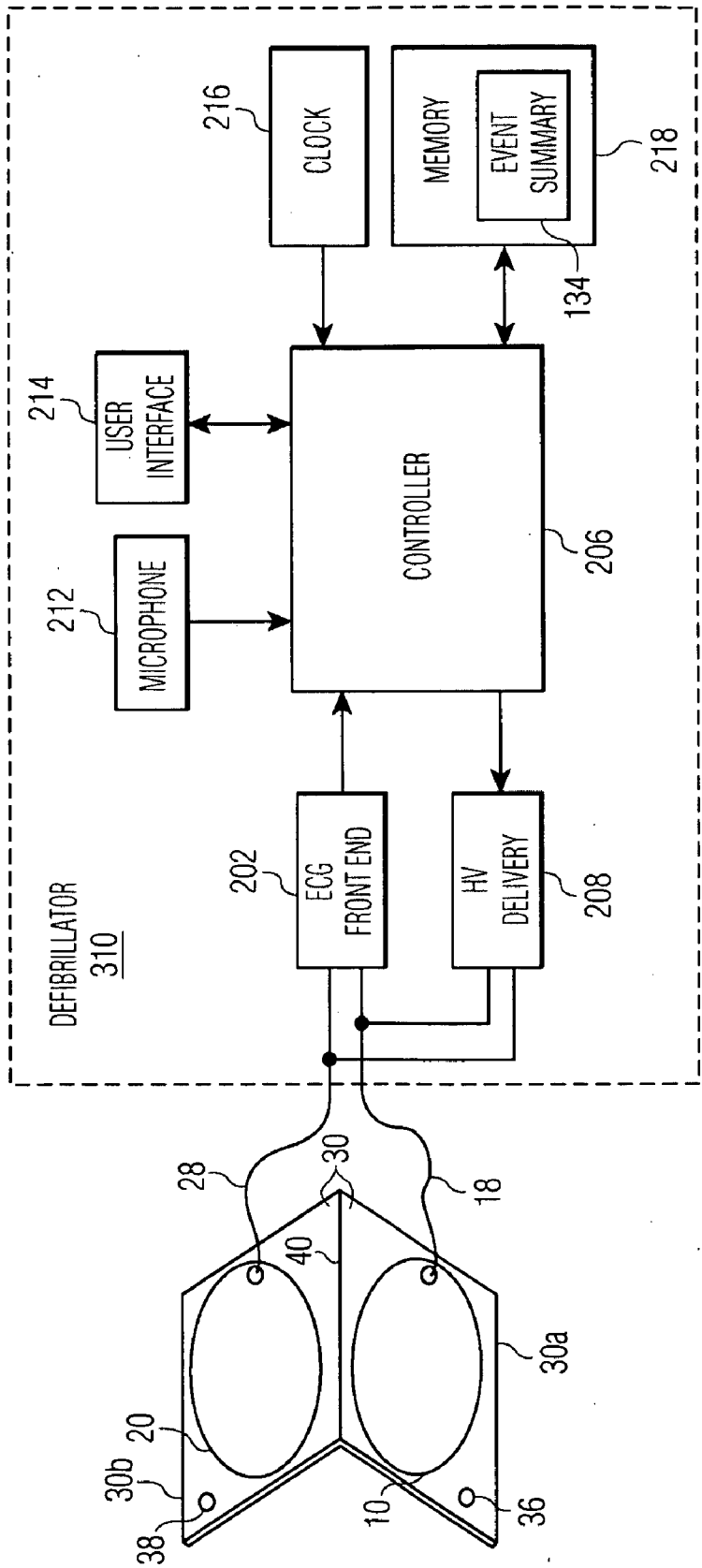

FIG. 3

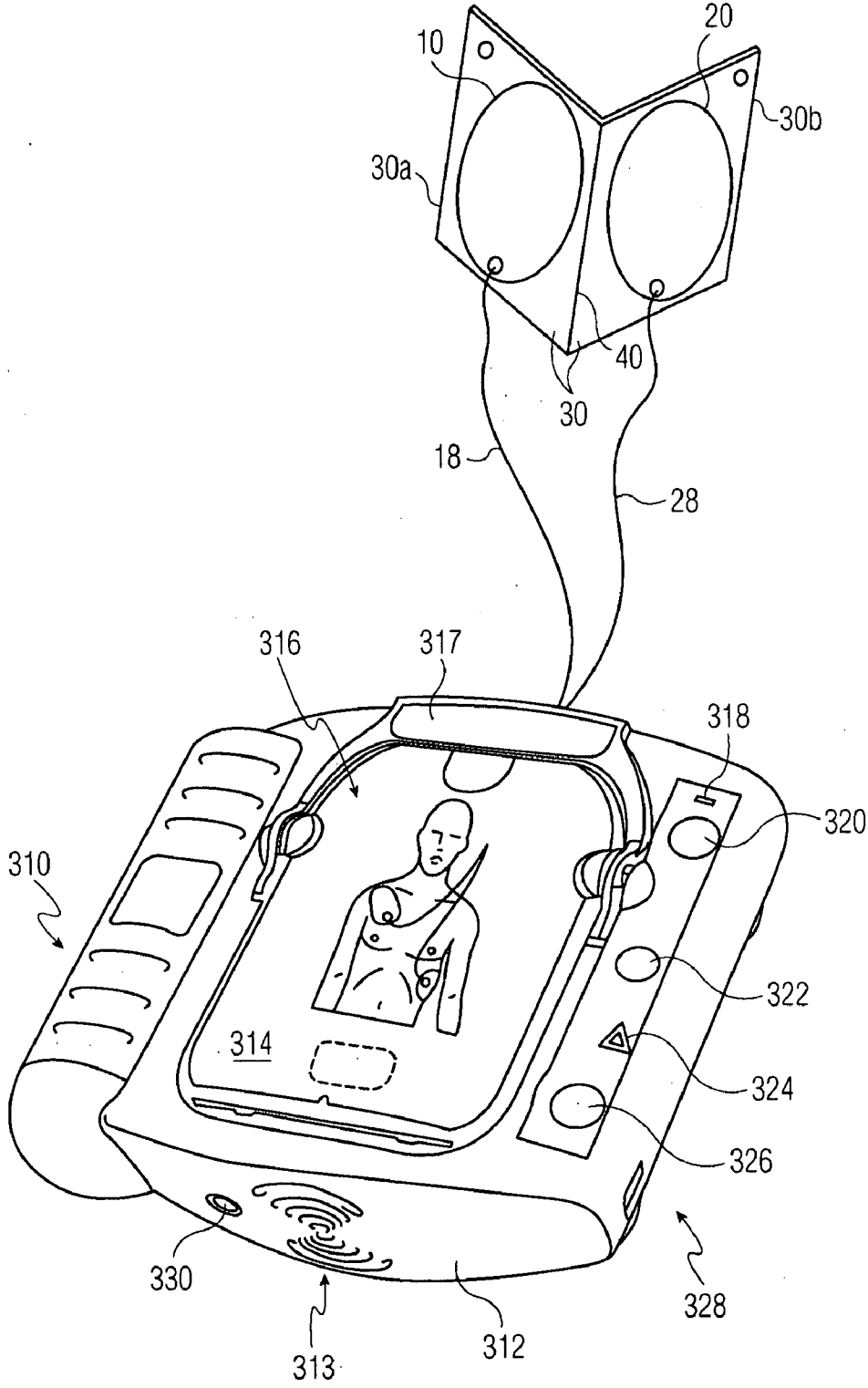

FIG. 4

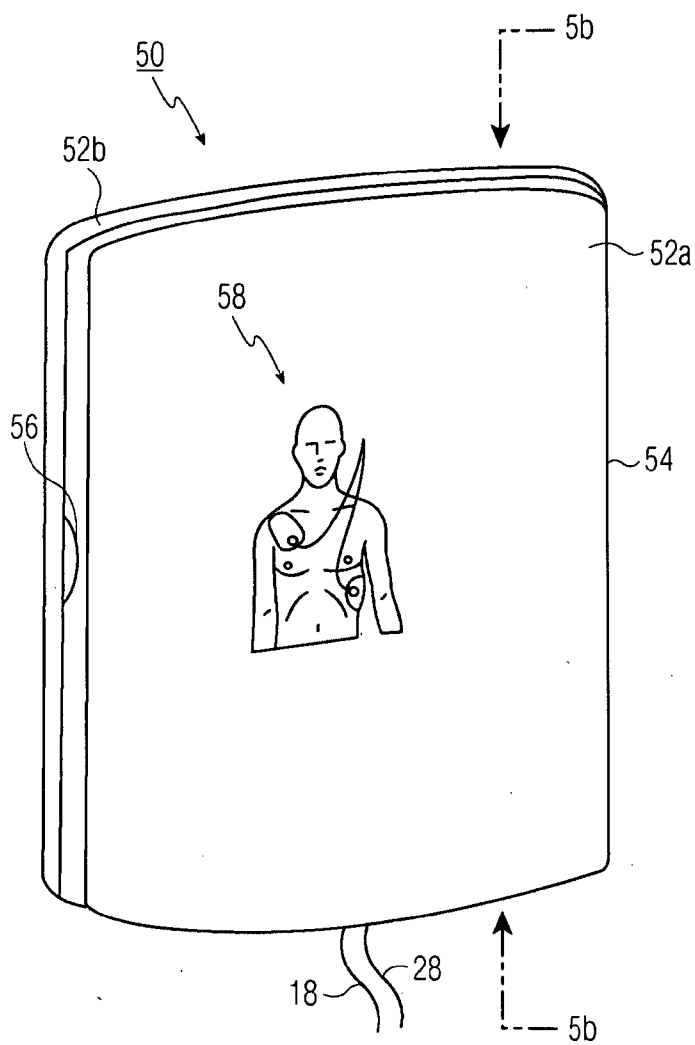

FIG. 5a

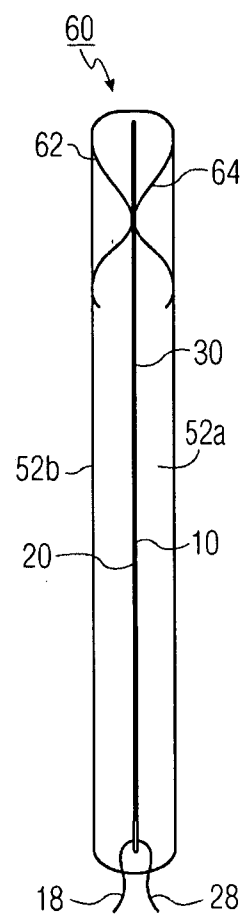
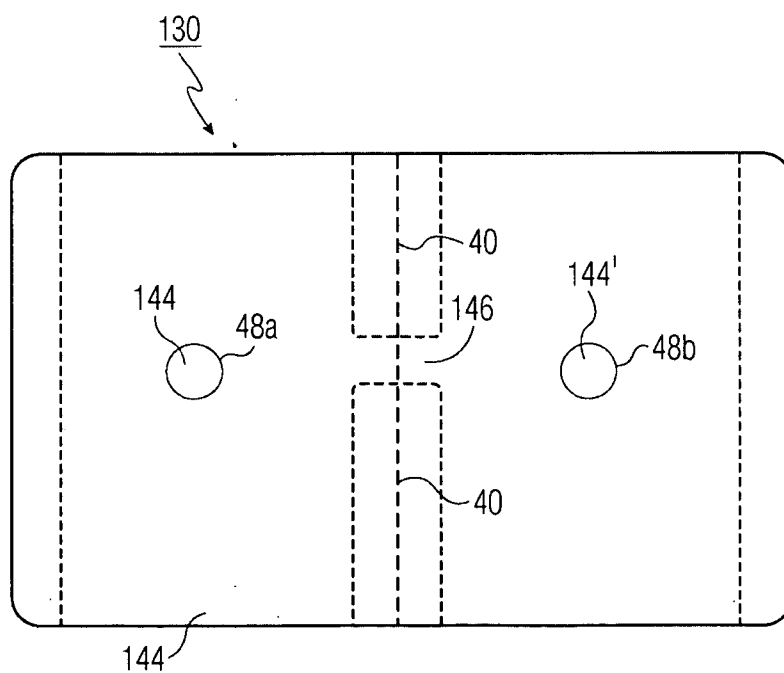
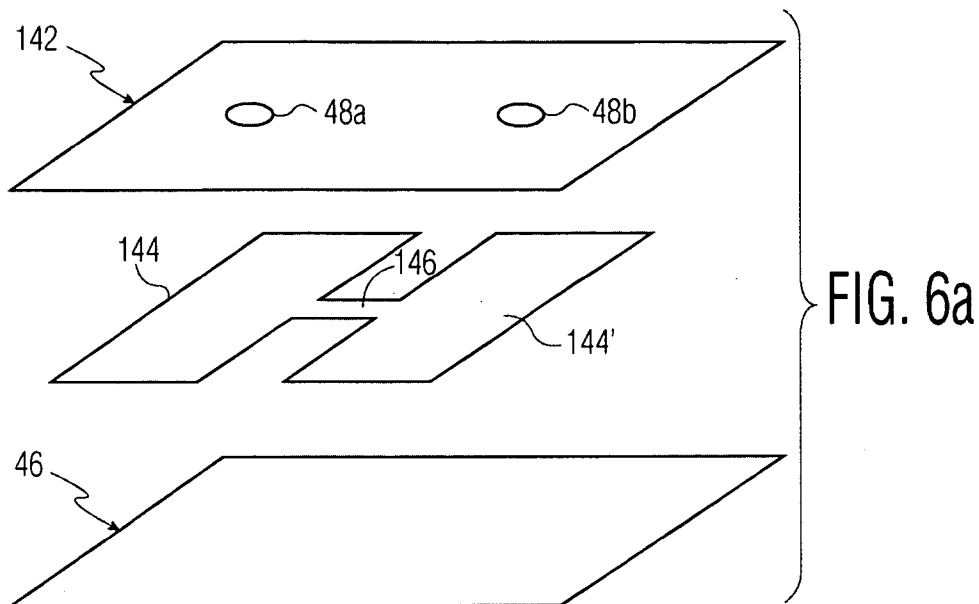

FIG. 5b



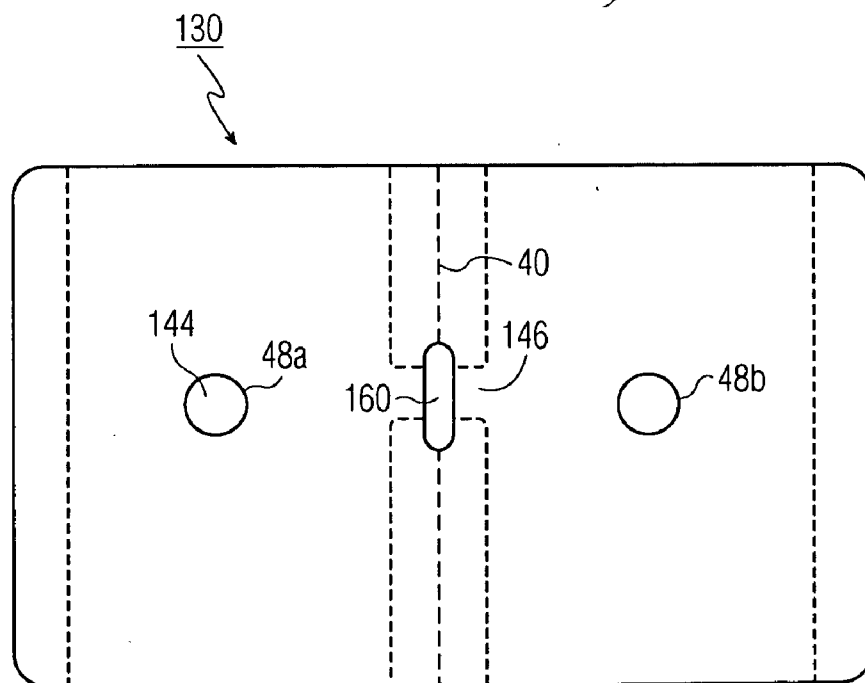
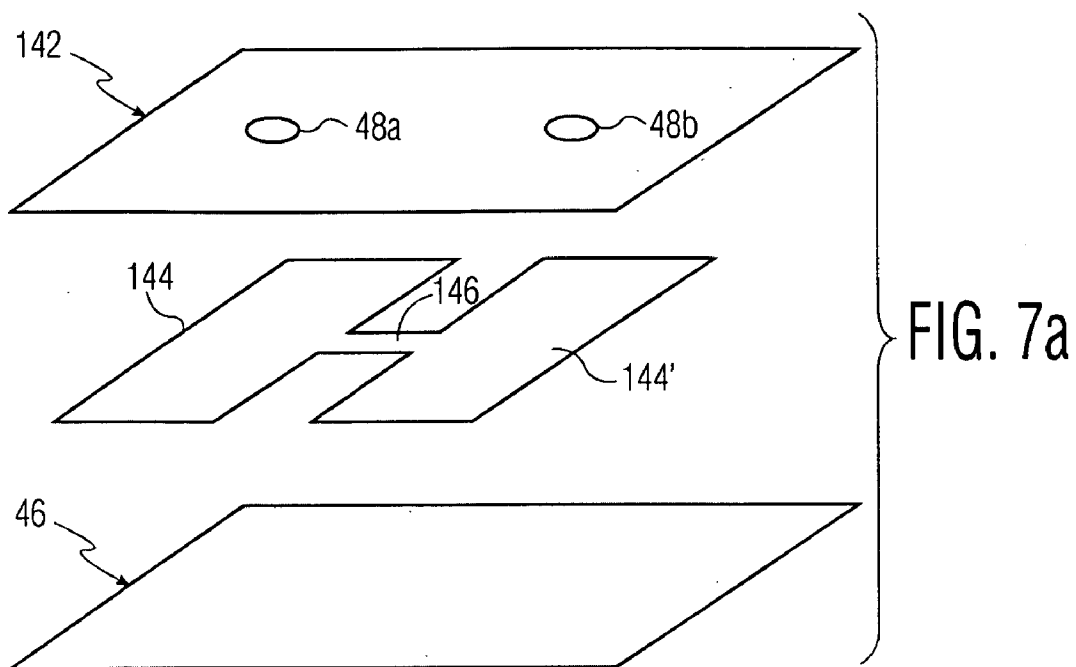

FIG. 7b

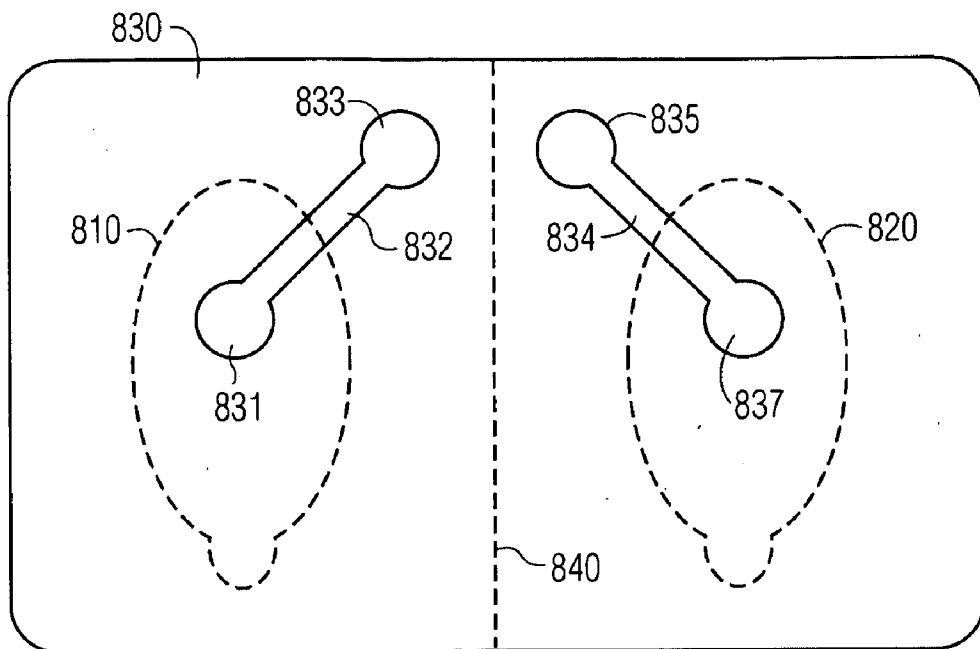

FIG. 8a

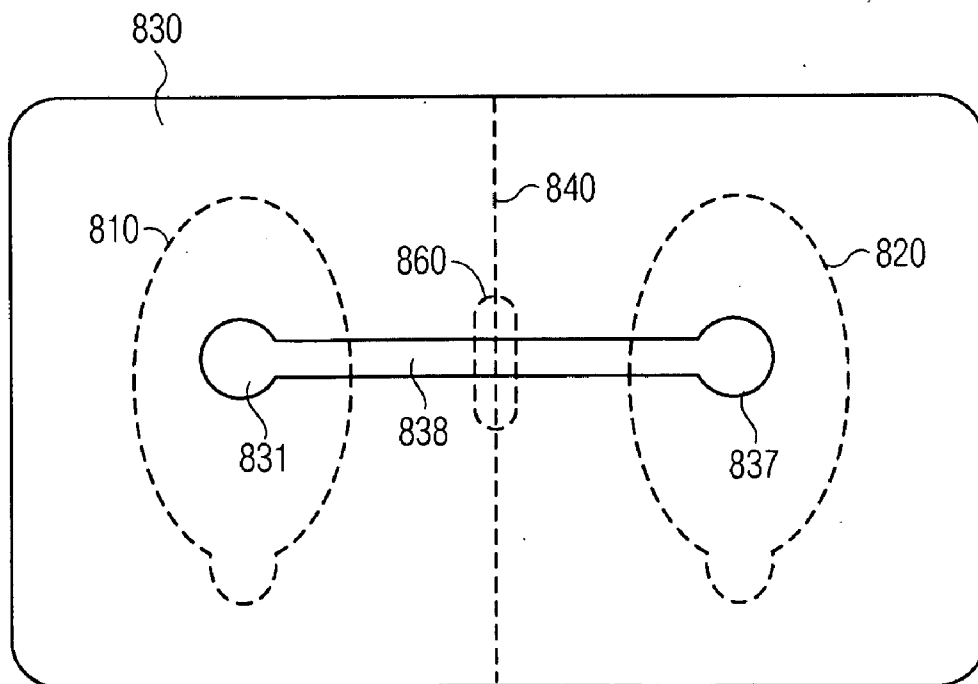

FIG. 8b

HALIBUT RELEASE LINER FOR A DEFIBRILLATOR ELECTRODE PAD

[0001] This invention relates to defibrillators for cardiac resuscitation and, in particular, to electrode pads for defibrillators.

[0002] Cardiac arrest is a life-threatening medical condition in which the patient's heart fails to provide blood flow to support life. A defibrillator can be used to deliver defibrillating shocks to a patient suffering from cardiac arrest. The defibrillator resolves this condition by delivering a high-voltage impulse to the heart in order to restore normal rhythm and contractile function in patients who are experiencing arrhythmia such as VF (ventricular fibrillation) or VT (ventricular tachycardia) that is not accompanied by spontaneous circulation. There are several classes of defibrillators, including manual defibrillators, implantable defibrillators, and automatic external defibrillators (AEDs). AEDs differ from manual defibrillators in that AEDs can automatically analyze the electrocardiogram (ECG) rhythm to determine if defibrillation is necessary. The defibrillator analyzes the ECG signal for signs of arrhythmia. If VF is detected, the defibrillator signals the rescuer that a shock is advised. After the detection of VF or other shockable rhythm, the rescuer presses a shock button on the defibrillator to deliver a defibrillation pulse to resuscitate the patient.

[0003] External defibrillators act through electrode pads applied across the chest of the patient. The electrodes adhesively attach to the patient and are used both to acquire an ECG signal from the patient's heart and to apply the defibrillating shock. AED electrodes commonly are formed by locating a foil or metallized electrode between a flexible nonconductive backing and a conductive adhesive gel. The conductive adhesive attaches the electrode securely to the patient. Gels, however, will dry out (desiccate) over time and have a finite shelf life. A typical shelf life for an electrode with gel adhesive is about two years, after which the electrodes must be replaced. Some AEDs use electrodes which are simply replaced when the safe shelf life period has expired. Other AEDs have an internal self-test circuit which periodically tests the electrodes and detects desiccation by an impedance change. For self-test electrodes the electrodes are electrically connected to each other to form a continuous closed loop circuit that is tested. The closed loop circuit is broken when the electrode pads are deployed for use.

[0004] In the case of both self-tested electrodes and non-self-tested electrodes, it is typical that the electrodes will be connected to the AED while stored prior to use so that the rescuer does not need to connect them; they are already pre-connected and ready for use. The self-test electrodes are pre-connected with the loop circuit closed for self-testing. The non-self-test electrodes are generally not connected in a closed loop circuit while stored prior to use. Hence, two different styles of electrodes are needed for self-testing and non-self-testing defibrillators. It would be desirable to have a set of defibrillator electrodes which can be used for both the self-test and the non-self-test configurations.

[0005] In accordance with the principles of the present invention, a release liner for defibrillator electrode pads is described which can be used for electrode pads connected in a closed loop for self-test and for electrode pads connected in an open circuit. The release liner includes two areas where electrode pads are attached prior to use. When the electrodes

are attached to the release liner the adhesive gel of each electrode is electrically connected to a conductor that provides the closed circuit for self-test electrodes. In one example shown below, the release liner is folded one way to complete the closed circuit and another way when the circuit is to be left open. In another example the release liner is normally in the closed circuit configuration but can be punched or cut to open the circuit prior to connection of the electrode pads to the defibrillator.

[0006] In the drawings:

[0007] FIG. 1 illustrates a halibut-style release liner and electrodes constructed in accordance with the principles of the present invention.

[0008] FIG. 2a illustrates a first example of a release liner of the present invention in an exploded view.

[0009] FIG. 2b is a plan view of the release liner of FIG. 2a after assembly.

[0010] FIG. 3 illustrates a halibut-style release liner and electrodes connected to a defibrillator.

[0011] FIG. 4 illustrates a halibut-style release liner and electrodes connected to an AED.

[0012] FIG. 5a is a perspective view of a case for a release liner and electrode of the present invention and FIG. 5b is a cross-sectional view of the case of FIG. 5a.

[0013] FIG. 6a illustrates a second example of a release liner of the present invention in an exploded view.

[0014] FIG. 6b is a plan view of the release liner of FIG. 6a after assembly and configured for a closed circuit connection to a defibrillator.

[0015] FIG. 7a illustrates the second example of a release liner of the present invention in an exploded view.

[0016] FIG. 7b is a plan view of the release liner of FIG. 7a after assembly and configured for an open circuit connection to a defibrillator.

[0017] FIG. 8a is a plan view of a halibut release liner which is folded to electrically connect the electrodes and uses a single release liner sheet.

[0018] FIG. 8b is a plan view of a halibut release liner which is punched or cut to electrically disconnect the electrodes and uses a single release liner sheet.

[0019] Referring first to FIG. 1, a halibut-style release liner 30 and electrode set 10,20 is shown in plan view. The style is referred to as halibut-style herein by reason of the resemblance of the relatively flat, flexible electrodes 10,20 to the fish of the same name when attached to the release liner. In this view the nonconductive backing surface of the electrodes 10,20 is facing the viewer. The adhesive gel on the other side is in contact with the release surface 42 of the release liner 30. A wire 18,28 is connected through the backing of each electrode 10,20 to the inner conductive layer of the electrode and is held in place by a fastener such as a rivet 16,26. Desiccation of the gel is retarded by sealing the nonconductive backing of each electrode to the moisture impermeable release surface 42 of the release liner. The seals 14, 24 are made around the periphery of the gel areas of the electrodes. A tab 12, 22 is formed at the end of the backing of the electrodes and may be grasped by a user to pull the electrodes away from the release liner when they are to be used.

[0020] Located inside the release liner 30 under each electrode 10,20 is a conductive sheet 44 (see FIG. 2) of metallic foil or other thin conductive material. The lateral extent of each sheet is indicated by dashed lines 32a,32b and 34a,34b. A hole 36, 38 is formed in the outer release surface layer 42 to give access to each conductive sheet. It is seen that each side

of the halibut release liner of FIG. 1 is a mirror image of the other about the center fold line 40 of the release liner 30. In accordance with the principles of the present invention, when the two sides are folded up and toward each other, the hole 36 will be opposite the hole 38 so that the conductive sheets visible through the holes can be brought into electrical contact with each other. When the release liner remains flat as shown in the drawing or when folded back along the fold line 40 so that the back sides (not visible in FIG. 1) are brought into contact with each other, there is no contact or electrical connection of the sheets within the release liner.

[0021] FIGS. 2a and 2b illustrate how the manner in which the release liner is folded dictates whether an open circuit or closed circuit is formed with the electrodes. In the exploded view of FIG. 2a, the nonconductive release surface layer 42 is seen to have four holes in it, the two previously described access holes 36,38 for the inner conductive sheets 44 and two holes 48a and 48b which underlie the electrodes when they are sealed to the layer 42.

[0022] The bottom layer of the release liner is a nonconductive layer 46. Between the layers 42 and 46 are the two conductive sheets 44 which underlie the electrode positions and holes 36,38 on each side of the release liner. When the conductive sheets are sealed between layers 42 and 46 their lateral sides in this example are positioned as shown by dashed lines 32a,32b for the left side conductive sheet and dashed lines 34a,34b for the right side conductive sheet as shown in FIG. 2b. Referring to FIG. 1 and FIG. 2b, it is apparent how the electrodes 10,20 can be electrically connected together. When the release liner is folded along fold line 40 so that the left and right upper sides are brought into contact with each other, an electrical circuit is completed between the wire 18 of the left electrode 10, the conductive layer of that electrode, its gel layer which is in contact with the left conductive sheet 44 of the release liner through the hole 48a, through holes 36 and 38 and the contact between the left and right conductive sheets 44 through those holes, from the right conductive sheet to the gel of the right electrode 20 through hole 48b, to the conductive layer of the electrode 20 and to its wire 28. When the two wires 18,28 are connected to a defibrillator a closed loop circuit is thus formed with the defibrillator. To keep the left and right conductive sheets 44 in electrical contact with each other when the release liner is folded closed in this configuration, a clip 150 or other fastening device may be applied to pinch the two conductive sheets 44 into contact with each other through holes 36 and 38 as shown in FIG. 2b. Other alternative holding techniques may be used such as fastening the sheets with a conductive adhesive when holes 36 and 38 are brought into contact with each other. In this closed loop circuit configuration the electrodes may be readily self-tested by signals applied by the defibrillator to which wires 18 and 28 are connected.

[0023] When the release liner and electrode are to be connected to a defibrillator which does not require closed loop connection of the electrodes it is sufficient that the conductive sheets visible through the holes 36 and 38 not be brought into contact with each other. The release liner can be folded the opposite way with the back sides of the release liner (layer 46) in contact with each other. If desired the clip 150 can be used to retain the release liner in this folded configuration. The release liner can alternatively be left unfolded as it is in FIGS. 1 and 2b.

[0024] Variations of this example will be readily apparent to those skilled in the art. For instance the conductive sheets

44 do not need to have the shape illustrated in this example; they can simply be conductors between the electrode hole 48a and the access hole 36 and between electrode hole 48b and access hole 38. One of the electrodes could be located on the other side (the layer 46 side) of the release liner provided that the electrode hole for that electrode were on that side of the release liner. The holes 36,38 could be punched through the release layer 42 but the punched material not removed unless the closed loop configuration were to be employed. Separate insulating covers could be used over one or both of the holes 36,38 to prevent electrical connection between the two conductive sheets 44 even in the forward folded condition. Other variations are also possible.

[0025] FIG. 3 shows the halibut release liner and electrodes when connected to a defibrillator 310. An ECG front end circuit 202 is connected to the wires 18,28 of the electrodes 10,20. In FIG. 3 the electrodes 10,20 are shown peripherally attached to the two sides 30a,30b of the release liner 30 prior to being peeled off of the release liner and attached to the patient. The ECG front end circuit 202 operates to amplify, buffer, filter and digitize an electrical ECG signal generated by the patient's heart and picked up by the electrodes to produce a stream of digitized ECG samples. The digitized ECG samples are provided to a controller 206 that performs an analysis to detect VF, shockable VT or other shockable rhythm. If a shockable rhythm is detected, the controller 206 sends a signal to HV (high voltage) delivery circuit 208 to charge a high voltage capacitor of circuit 208 in preparation for delivering a shock, and a shock button on a user interface 214 is activated to begin flashing. The rescuer 220 is then advised by an audible instruction to keep away from the patient ("hands off" instruction). When the rescuer presses the shock button on the user interface 214 a defibrillation shock is delivered from the HV delivery circuit 208 to the patient through the electrodes 10,20.

[0026] The controller 206 is coupled to further receive input from a microphone 212 to produce a voice strip. The analog audio signal from the microphone 212 is preferably digitized to produce a stream of digitized audio samples which may be stored as part of an event summary 134 in a memory 218. The user interface 214 may consist of a display, an audio speaker, and control buttons such as an on-off button and a shock button for providing user control as well as visual and audible prompts. A user interface of the present invention may also include one or more control buttons for selecting a rescue protocol stored in memory 218 to be carried out during a rescue. A clock 216 provides real-time or elapsed time clock data to the controller 206 for time-stamping information contained in the event summary 134. The memory 218, implemented either as on-board RAM, a removable memory card, or a combination of different memory technologies, operates to store the event summary 134 digitally as it is compiled during the treatment of the patient 210. The event summary 134 may include the streams of digitized ECG, audio samples, and other event data as previously described.

[0027] FIG. 4 illustrates halibut electrodes of the present invention coupled to a defibrillator 310. The defibrillator 310 represents a semi-automatic external defibrillator (AED). However, other types of external defibrillators can be used as well. The AED 310 is housed in a rugged polymeric case 312 which protects the electronic circuitry inside the case, which was previously described with reference to FIG. 3, and also protects the rescuer from shocks. Attached to the case 312 by electrical leads 18,28 are a pair of halibut electrodes 10,20

attached to the two sides **30a, 30b** of a release liner **30**. Prior to use the electrode pads **10, 20** are retained in a cartridge **314** located in a recess on the top side of the AED **310**. The electrode pads are accessed for use by pulling up on a handle **317** which allows removal of a plastic cover over the electrodes **10, 20**. The user interface is on the right side of the AED **310**. A small ready light **318** informs the rescuer of the readiness of the AED **310**. In this embodiment the ready light blinks after the AED **310** has been properly set up and is ready for use. The ready light is on constantly when the AED **310** is in use, and the ready light is off or flashes in an alerting color when the AED **310** needs attention.

[0028] Below the ready light is an on/off button **320**. The on/off button is pressed to turn on the AED **310** for use. To turn off the AED **310** the rescuer holds the on/off button down for one second or more. An information button **322** flashes when information is available for the rescuer. The rescuer depresses the information button to access the available information. A caution light **324** blinks when the AED **310** is acquiring heartbeat information from the patient and lights continuously when a shock is advised, alerting the rescuer and others that no one should be touching the patient during these times. A shock button **326** is depressed to deliver a shock after the AED **310** informs the rescuer that a shock is advised. An infrared port **328** on the side of the AED **310** is used to transfer data between the AED **310** and a computer. This data port finds used after the patient has been rescued and a physician desires to have the AED **310** event data downloaded to his or her computer for detailed analysis. A speaker **313** provides voice instructions to the rescuer to guide the rescuer through the use of the AED **310** to treat the patient. A beeper **330** is provided which “chirps” when the AED **310** needs attention such as electrode pad replacement or a new battery.

[0029] FIGS. **5a** and **5b** illustrate a case or cartridge **50** for storing halibut electrode pads prior to use. The case **50** in this example is similar to the familiar cases which retain DVDs and can be made of a polymeric material, for instance. The two halves of the case **52a, 52b** are hinged together at one side by a hinge **54** and can be opened by depressing an indentation **56** on the other side of the case. While the case can be made to seal airtight as by the use of a gasket where the two halves come together or can be shrink-wrap sealed, this is not necessary as the peripheral sealing of the electrode pads **10, 20** to a release liner **30** of polymeric or other moisture impermeable material will provide the necessary hermetic sealing of the electrode gel prior to use. A torso illustration **58** on the case illustrates the proper attachment of the electrodes to the patient.

[0030] The cross-sectional view of FIG. **5b** shows that there is a spring clip **60** or other fastening device located inside the case. The two halves **62, 64** of the spring clip are forced together when the case is closed, clamping the release liner **30** between them at the location of the holes **36, 38**. When the release liner is folded so that the two holes **36, 38** oppose each other, this clamping action maintains contact of the two conductive sheets **44** of the release liner, completing the closed electrical circuit between the two electrode pads for self-test by a defibrillator attached to the electrical wires or leads **18, 28**. The case can also be used if the electrodes are not to be electrically connected by folding the release liner so that the holes are on the outside facing away from each other, in which case the clip **60** functions to retain the halibut electrodes and release liner in the case with no electrical connection between

them. Thus, the same case **50** and halibut electrodes **10, 20** and release liner **30** can be used for defibrillators which require and do not require electrical connection between the electrodes, simply by the way in which the release liner is folded inside the case.

[0031] FIGS. **6a** and **6b** illustrate another example of a release liner for halibut electrodes of the present invention. In the exploded view of FIG. **6a** the nonconductive release surface layer **142** of the release liner is seen to have only two holes, the holes **48a** and **48b** which underlie the electrodes when they are sealed to the layer **142** and permit electrical contact to an inner conductive sheet located between the outer nonconductive layers **142** and **46**. The inner conductive sheet is composed of two sides **144** and **144'** which underlie the holes **48a** and **48b** which are joined by a bridging portion **146**. Thus the conductive sheet forms a continuous electrical connection between the two electrodes when they are attached to the release liner, as is evident from the plan view of the assembled release liner **130** of FIG. **6b**. When the electrodes are attached to the surface **142** of the release liner **130** they are electrically connected to each other and ready for use with a defibrillator which requires electrically interconnected electrodes.

[0032] The release liner configuration of FIGS. **6a** and **6b** can be converted to one in which the attached electrodes are not electrically interconnected as shown in FIGS. **7a** and **7b**. This is done by breaking the electrical connection between the two sides of the release liner **130**. In the example of FIG. **7b** this is done by punching a hole **160** through the release liner which severs the bridging portion **146** between the two halves **144** and **144'** of the inner conductive sheet. The two halves **144** and **144'** of the conductive sheet are thus no longer electrically connected to each other. Unlike the embodiment of FIGS. **1, 2a** and **2b**, the electrical interconnection or lack thereof is not determined by the manner in which the release liner is folded; it is determined by whether the two halves of the conductive sheet remain connected or are disconnected. The example of FIGS. **6a, 6b, 7a** and **7b** can be folded or unfolded in either configuration. Also unlike the earlier embodiment, the severing of the two halves of the conductive sheet make the non-interconnected configuration permanent, absent means to reconnect the two halves of the conductive sheet. Another way to view the two embodiments is that the two halves of the conductive sheet are nominally not connected in the FIGS. **1, 2a, 2b** embodiment and nominally electrically connected in the FIGS. **6a, 6b, 7a, 7b** embodiment. Breaking the electrical connection of the latter changes the configuration to use defibrillators requiring non-connected electrodes. For example, at the end of the manufacturing process the two halves of the conductive sheet can be left connected and the halibut electrodes used with defibrillators requiring electrically connected electrodes, or the bridging portion **146** can be cut and the halibut electrodes used with defibrillators requiring electrically disconnected electrodes. The same electrode manufacturing line can thus make electrodes for both types of defibrillators.

[0033] FIG. **8a** is another example of a halibut release liner of the present invention. In this example the release liner comprises a single sheet **830** of moisture impermeable material to which electrodes are attached as above with the conductive gel facing the sheet. When the electrodes are peripherally sealed to the release liner sheet **830** the conductive gel of the electrodes is sealed as before between the moisture impermeable backing of the electrode and the moisture

impermeable release liner sheet **830**, protecting the gel from desiccation. Dashed lines **810** and **820** indicate the areas of the release liner where the electrodes are to be attached. The release liner sheet **830** may be formed of a polymeric or plastic material or other material that is nonconductive. Conductors **832** and **834** formed of thin foil, metallized ink, or other thin conductor is laminated or printed on the sheet with a portion of each positioned to contact the electrically conductive (gel) surface of the electrode and another portion extending outside of the attachment areas of the electrodes. In this example the conductors each have one rounded end **831**, **837** which makes contact with the conductive gel of an attached electrode and another rounded end **833**, **835** outside of the attachment areas **810**, **820**. In this example the conductors **832**, **834** are laminated or printed on the side of the sheet **830** where the electrodes are to be attached, but they could also be located on the opposite side of the sheet **830** and make electrical contact through holes in the sheet. The conductors could also be embedded or molded into the sheet **830**. The electrodes can be attached on the same side or on opposite sides of the sheet **830**.

[0034] When the electrodes are attached in the electrode attachment areas **810** and **820**, each attached electrode will be in electrical contact with a respective one of the conductors **832** and **834**. When the sheet **840** is folded along fold line **840** so that conductor ends **833** and **835** are brought into contact with each other, the electrodes will be electrically connected to each other for a defibrillator which requires electrically connected electrodes for self-test. But when the sheet is folded the other way or left unfolded so that there is no electrical contact between conductors **832** and **834**, the electrodes and release liner are suitable for connection to a defibrillator which does not require or cannot have preconnected electrodes electrically connected to each other.

[0035] The release liner sheet **830** can be opaque, translucent, or transparent. A transparent sheet will enable a user to visually inspect the conductive gel of the electrodes through the sheet **830** while the electrodes are attached to the release liner to discern any deterioration of the gel. The gel may contain a substance or material which changes color or otherwise changes visually when the moisture content of the gel changes, providing a quick and easy means for determining whether the electrodes are suitable for use.

[0036] FIG. **8b** is another example of the present invention which, as in the example of FIG. **8a**, uses a single release liner sheet **830**. Instead of separate conductors, a conductor **838** is laminated to, printed on, or embedded in the sheet **830** and extends between the attachment position **810** for one electrode and the attachment position **820** for the other electrode. As before, the conductor **838** is preferably on the same side of the sheet **830** to which the electrodes are attached, but could also be on the other side and extend through the sheet to the two electrodes. When electrodes are attached to the release liner sheet **830** in the positions shown, the electrodes are electrically connected to each other by the conductor **838**. If the conductor **838** is broken such as by punching a hole **860** through the conductor or through the conductor and the release liner sheet, the attached electrodes are rendered electrically disconnected with each other.

[0037] Other variations will readily occur to those skilled in the art. For instance, the conductors for the example of FIG. **8a** could simply comprise small conductors at the locations and of the size of ends **831** and **837** with holes in sheet **830** behind the conductors providing access to conductors **831**

and **837** on the back of sheet **830**. When the release liner sheet **830** is folded back-to-back, the conductors **831** and **837** can be brought into contact with each other through the holes in the sheet **830** and clamped or attached into continuous contact to electrically connect the two electrodes. Folding the sheet the opposite way or leaving the sheet unfolded would leave the electrodes electrically disconnected with each other. Another variation would be to mount the halibut electrodes on separate release liners rather than one release liner which is folded, with each separate release liner resembling one half of the folded release liner. Other variations of the examples described above are also possible.

What is claimed is:

1. A release liner for electrodes comprising:
 - an outer nonconductive surface to which electrodes may be attached;
 - a conductive layer in electrical contact with each attached electrode and nominally electrically disconnected with each other; and
 - an access to the conductive layer of each attached electrode,
 wherein the release liner may be folded one way to bring the conductive layer of each attached electrode into electrical connection by means of the access, or folded another way to leave the conductive layer of each attached electrode in electrical disconnection.
2. The release liner of claim 1, wherein the access comprises a hole through the outer nonconductive surface.
3. The release liner of claim 1, further comprising a second outer nonconductive surface,
 - wherein the conductive layer is sandwiched between the first and second nonconductive surfaces.
4. The release liner of claim 3, wherein the conductive layer further comprises first and second inner conductive layers.
5. The release liner of claim 4, further comprising first and second holes accessing the inner conductive layers at locations where electrodes are to be attached to the release layer; and
 - third and fourth holes accessing the inner conductive layers outside of the locations where electrodes are to be attached to the release liner.
6. The release liner of claim 5, wherein the third and fourth holes are located to oppose each other and allow contact of the inner conductive layers when the release liner is folded one way.
7. The release liner of claim 6, further comprising a fastening device which retains the inner conductive layers in contact with each other through the third and fourth holes when the release liner is folded one way.
8. The release liner of claim 5, wherein the first hole is located in the first nonconductive surface and the second hole is located in the second nonconductive surface.
9. The release liner of claim 5, wherein the first and second holes are located in the same nonconductive surface.
10. The release liner of claim 1, wherein the nonconductive surface is impermeable to moisture.
11. A release liner for electrodes comprising:
 - an outer nonconductive surface to which electrodes may be attached;
 - a conductive layer in electrical contact with each attached electrode; and
 - an access to the conductive layer of each attached electrode,

wherein the conductive layer of each attached electrode may be electrically separated.

12. The release liner of claim **11**, wherein a first portion of the conductive layer underlies a first location where an electrode may be attached to the outer nonconductive surface and a second portion of the conductive layer underlies a second location where an electrode may be attached to the outer conductive surface,

wherein the first and second portions of the conductive layer are nominally electrically connected and may be electrically disconnected.

13. The release liner of claim **12**, further comprising an electrically conductive member connecting the first and second portions,

wherein the electrically conductive member may be broken to electrically disconnect the first and second portions.

14. The release liner of claim **13**, wherein the outer nonconductive surface further comprises first and second nonconductive layers sandwiching the conductive layer.

15. The release liner of claim **14**, wherein the access further comprises holes through at least one of the nonconductive layers at the first and second locations.

16. A release liner and electrode assembly comprising:
first and second moisture impermeable outer nonconductive layers;

a pair of electrodes attached to at least one of the first and second nonconductive layers;

a pair of inner conductive layers sandwiched between the first and second outer layers;

a hole enabling electrical connection of each electrode to an inner conductive layer;

a pair of holes outside the periphery of the attached electrodes and affording access to the inner conductive layers,

wherein the release liner may be folded to bring the pair of holes into opposition such that the inner conductive layers are in electrical contact with each other.

17. A release liner and electrode assembly comprising:
first and second moisture impermeable outer nonconductive layers;

a pair of electrodes attached to at least one of the first and second nonconductive layers;

a pair of inner conductive layers sandwiched between the first and second outer layers and electrically connected by a bridging member;

a hole enabling electrical connection of each electrode to an inner conductive layer,

wherein the electrodes may be electrically disconnected by breaking the bridging member.

18. A method for packaging a pair of electrodes and a release liner comprising:

attaching each electrode to an moisture impermeable surface of a release liner with the electrically conductive side of the first electrode in contact with a first conductor of the release liner and the electrically conductive side of the second electrode in contact with a second conductor of the release liner; and

folding the release liner one way to bring the first conductor of the release liner into contact with the second conductor, or not folding the release liner to bring the first conductor into contact with the second conductor.

19. A method for packaging a pair of electrodes and a release liner comprising:

attaching each electrode to an moisture impermeable surface of a release liner with the electrically conductive side of each electrode in contact with a conductor of the release liner extending between the areas to which the electrodes are attached; and

breaking the conductor to cause the electrodes to be electrically disconnected, or not breaking the conductor to leave the electrodes electrically connected to each other by the conductor.

* * * * *