



US 20230405408A1

(19) **United States**

(12) **Patent Application Publication**  
**Madson et al.**

(10) **Pub. No.: US 2023/0405408 A1**  
 (43) **Pub. Date: Dec. 21, 2023**

(54) **BUOYANT HIGH COEFFICIENT OF RESTITUTION (COR) GOLF BALL INCORPORATING AERODYNAMICS TARGETING FLIGHT TRAJECTORY**

(71) Applicant: **Acushnet Company**, Fairhaven, MA (US)

(72) Inventors: **Michael R. Madson**, Easton, MA (US); **Courtney N. Engle**, Fall River, MA (US); **Derek A. Ladd**, Acushnet, MA (US); **Michael J. Sullivan**, Old Lyme, CT (US); **Mark L. Binette**, Mattapoisett, MA (US); **William E. Morgan**, Rehoboth, MA (US)

(73) Assignee: **Acushnet Company**, Fairhaven, MA (US)

(21) Appl. No.: **18/212,843**

(22) Filed: **Jun. 22, 2023**

**Related U.S. Application Data**

(60) Division of application No. 17/352,607, filed on Jun. 21, 2021, now Pat. No. 11,684,824, which is a continuation-in-part of application No. 16/658,357, filed on Oct. 21, 2019, now Pat. No. 11,040,253, which is a division of application No. 15/712,267, filed on Sep. 22, 2017, now Pat. No. 10,549,157, which is a continuation-in-part of application No. 14/467,083, filed on Aug. 25, 2014, now Pat. No. 10,188,912, which is a continuation-in-part of application No. 14/145,593, filed on Dec. 31, 2013, now Pat. No. 9,427,630, which is a continuation-in-part of application No. 13/692,583, filed on Dec. 3, 2012, now Pat. No. 8,740,726, which is a continuation of application No. 13/169,753, filed on Jun. 27, 2011, now Pat. No. 8,323,123, which is a continuation of application No. 12/795,295, filed on Jun. 7, 2010, now Pat. No. 7,967,701, which is a continuation of application No. 12/125,306, filed on May 22, 2008, now Pat. No. 7,731,607, which is a continuation-in-part of application No. 11/972,240, filed on Jan. 10, 2008, now Pat. No. 7,722,482, which is a continuation-in-part of application No. 11/738,759, filed on Apr. 23, 2007, now Pat. No. 7,517,289, said application No. 14/145,593 is a continuation-in-part of application No. 13/758,041, filed on Feb. 4, 2013, now Pat. No. 8,740,724, which is a continuation of application No. 13/329,398, filed on Dec. 19, 2011, now Pat. No. 8,382,611, which is a continuation of application No. 12/697,368, filed on Feb. 1, 2010, now Pat. No. 8,079,920, which is a continuation of application No. 12/125,260, filed on May 22, 2008, now Pat. No. 7,654,916, which is a continuation-in-part of application No. 11/694,007, filed on Mar. 30, 2007, now Pat. No. 7,452,290, which is a continuation-in-part of application No. 12/048,003, filed on Mar. 13, 2008, now abandoned, which is a continuation-in-part of application No. 12/048,021, filed on Mar. 13, 2008, now Pat. No. 8,357,059, said application No. 14/145,

593 is a continuation-in-part of application No. 13/584,167, filed on Aug. 13, 2012, now Pat. No. 8,702,536, which is a continuation of application No. 13/164,233, filed on Jun. 20, 2011, now Pat. No. 8,241,147, which is a continuation of application No. 12/125,320, filed on May 22, 2008, now Pat. No. 7,963,862, which is a continuation-in-part of application No. 11/738,759, filed on Apr. 23, 2007, now Pat. No. 7,517,289, which is a continuation-in-part of application No. 11/972,259, filed on Jan. 10, 2008,

(Continued)

**Publication Classification**

- (51) **Int. Cl.**  
*A63B 37/00* (2006.01)  
*C08L 23/08* (2006.01)  
*A63B 37/02* (2006.01)  
*C08L 51/06* (2006.01)  
*C08K 5/098* (2006.01)  
*C08L 23/06* (2006.01)  
*C08L 75/04* (2006.01)  
*C08L 33/04* (2006.01)  
*C08F 279/02* (2006.01)
- (52) **U.S. Cl.**  
 CPC ..... *A63B 37/0063* (2013.01); *C08L 23/0876* (2013.01); *A63B 37/02* (2013.01); *A63B 37/0092* (2013.01); *A63B 37/008* (2013.01); *A63B 37/0076* (2013.01); *A63B 37/0075* (2013.01); *A63B 37/0072* (2013.01); *A63B 37/0064* (2013.01); *A63B 37/0062* (2013.01); *A63B 37/0051* (2013.01); *A63B 37/0049* (2013.01); *A63B 37/0043* (2013.01); *A63B 37/0003* (2013.01); *A63B 37/0083* (2013.01); *C08L 23/0869* (2013.01); *C08L 51/06* (2013.01); *A63B 37/0039* (2013.01); *C08K 5/098* (2013.01); *A63B 37/0045* (2013.01); *C08L 23/06* (2013.01); *C08L 75/04* (2013.01); *A63B 37/0074* (2013.01); *A63B 37/0082* (2013.01); *C08L 33/04* (2013.01); *A63B 37/0078* (2013.01); *A63B 37/0084* (2013.01); *C08F 279/02* (2013.01); *A63B 2209/00* (2013.01); *A63B 2225/605* (2013.01)

(57) **ABSTRACT**

Buoyant dimpled golf ball having CoR $\geq$ 0.810, specific gravity <1.00 g/cc, initial velocity  $\geq$ 250 ft/s, first aerodynamic coefficient magnitude between about 0.25 and about 0.30 and first aerodynamic force angle between about 29 degrees and 34 degrees at Reynolds Number of 230000 and spin ratio of 0.085; and second aerodynamic coefficient magnitude between about 0.26 and about 0.31 and second aerodynamic force angle between about 31 degrees and 36 degrees at Reynolds Number of 180000 and spin ratio of 0.101. Golf ball may additionally have third aerodynamic coefficient magnitude between about 0.27 and about 0.32 and third aerodynamic force angle between about 34 degrees and 39 degrees at Reynolds Number of 133000 and spin ratio of 0.133; and fourth aerodynamic coefficient magnitude between about 0.33 and about 0.38 and fourth aerodynamic force angle between about 38 degrees and 43 degrees at Reynolds Number of 89000 and spin ratio of 0.183.

**Related U.S. Application Data**

now Pat. No. 7,753,810, said application No. 15/712,267 is a continuation-in-part of application No. 15/197,988, filed on Jun. 30, 2016, now abandoned, which is a division of application No. 14/467,089, filed on Aug. 25, 2014, now Pat. No. 9,381,403, which is a continuation-in-part of application No. 14/145,648, filed on Dec. 31, 2013, now Pat. No. 9,486,674, which is a continuation-in-part of application No. 14/017,979, filed on Sep. 4, 2013, now Pat. No. 9,327,166, which is a continuation-in-part of application No. 13/872,354, filed on Apr. 29, 2013, now Pat. No. 9,302,156, said application No. 14/145,648 is a continuation-in-part of application No. 13/913,670, filed on Jun. 10, 2013, now Pat. No. 9,126,083, which is a continuation-in-part of application No. 13/611,376, filed on Sep. 12, 2012, now abandoned, said application No. 15/712,267 is a continuation-in-part of application No. 14/467,086, filed on Aug. 25, 2014, now abandoned, which is a continuation-in-part of application No. 14/145,633, filed on Dec. 31, 2013, now Pat. No. 10,668,328, which is a continuation-in-part of application No. 13/736,993, filed on Jan. 9, 2013, now abandoned, which is a continuation-in-part of application No. 13/736,997, filed on Jan. 9, 2013, now abandoned, which is a continuation-in-part of application No. 13/737,026, filed on Jan. 9, 2013, now abandoned, which is a continuation-in-part of application No. 13/737,041, filed on Jan. 9, 2013, now abandoned.

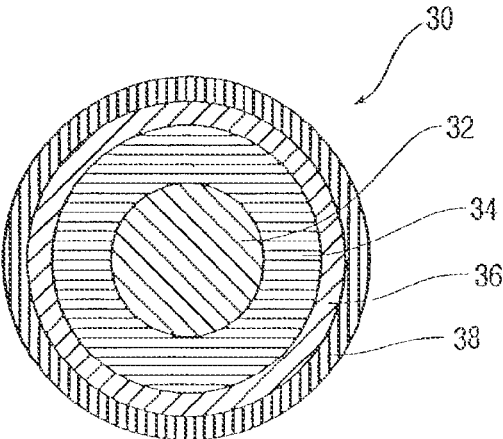

FIG. 1

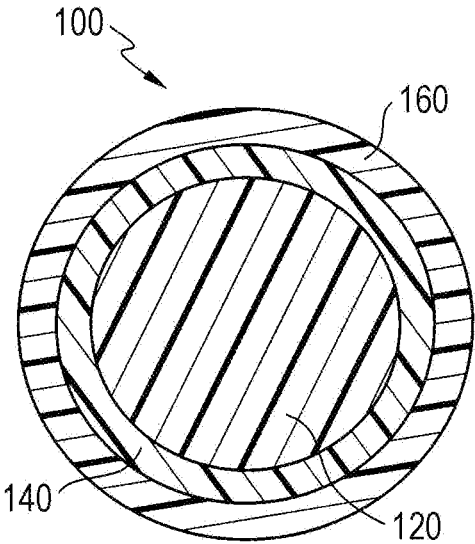

FIG. 2

**BUOYANT HIGH COEFFICIENT OF  
RESTITUTION (COR) GOLF BALL  
INCORPORATING AERODYNAMICS  
TARGETING FLIGHT TRAJECTORY**

**CROSS REFERENCE TO RELATED  
APPLICATIONS**

**[0001]** This application is a divisional of co-pending U.S. patent application Ser. No. 17/352,607, filed Jun. 21, 2021, which is a continuation-in-part of U.S. patent application Ser. No. 16/658,357, filed Oct. 21, 2019, now U.S. Pat. No. 11,040,253, which is a divisional of U.S. patent application Ser. No. 15/712,267, filed Sep. 22, 2017, now U.S. Pat. No. 10,549,157, which is a continuation-in-part of U.S. patent application Ser. No. 14/467,083, filed Aug. 25, 2014, now U.S. Pat. No. 10,188,912, which is a continuation-in-part of U.S. patent application Ser. No. 14/145,593, filed Dec. 31, 2013, now U.S. Pat. No. 9,427,630, which is a continuation-in-part of U.S. patent application Ser. No. 13/692,583, filed Dec. 3, 2012, now U.S. Pat. No. 8,740,726, which is a continuation of U.S. patent application Ser. No. 13/169,753, filed Jun. 27, 2011, now U.S. Pat. No. 8,323,123, which is a continuation of U.S. patent application Ser. No. 12/795,295, filed Jun. 7, 2010, now U.S. Pat. No. 7,967,701, which is a continuation of U.S. patent application Ser. No. 12/125,306, filed May 22, 2008, now U.S. Pat. No. 7,731,607, which is a continuation-in-part of U.S. patent application Ser. No. 11/972,240, filed Jan. 10, 2008, now U.S. Pat. No. 7,722,482, and U.S. patent application Ser. No. 11/738,759, filed Apr. 23, 2007, now U.S. Pat. No. 7,517,289.

**[0002]** U.S. patent application Ser. No. 14/145,593 is also a continuation-in-part of U.S. patent application Ser. No. 13/758,041, filed Feb. 4, 2013, which is a continuation of U.S. patent application Ser. No. 13/329,398, filed Dec. 19, 2011, which is a continuation of U.S. patent application Ser. No. 12/697,368, filed Feb. 1, 2010, now U.S. Pat. No. 8,079,920, which is a continuation of U.S. patent application Ser. No. 12/125,260, filed May 22, 2008, now U.S. Pat. No. 7,654,916. U.S. patent application Ser. No. 12/125,260 is a continuation-in-part of U.S. patent application Ser. No. 11/694,007, filed Mar. 30, 2007, now U.S. Pat. No. 7,452,290; a continuation-in-part of U.S. patent application Ser. No. 12/048,003, filed Mar. 13, 2008, now abandoned; and a continuation-in-part of U.S. patent application Ser. No. 12/048,021, filed Mar. 13, 2008, now U.S. Pat. No. 8,357,059.

**[0003]** U.S. patent application Ser. No. 14/145,593 is also a continuation-in-part of Ser. No. 13/584,167, filed Aug. 13, 2012, which is a continuation of U.S. patent application Ser. No. 13/164,233, filed Jun. 20, 2011, which is a continuation of U.S. patent application Ser. No. 12/125,320, filed May 22, 2008, now U.S. Pat. No. 7,963,862, which is a continuation-in-part of U.S. patent application Ser. No. 11/738,759, filed Apr. 23, 2007, now U.S. Pat. No. 7,517,289. U.S. patent application Ser. No. 12/125,320 is also a continuation-in-part of U.S. patent application Ser. No. 11/972,259, filed Jan. 10, 2008, now U.S. Pat. No. 7,753,810.

**[0004]** U.S. patent application Ser. No. 15/712,267 is also a continuation-in-part of U.S. patent application Ser. No. 15,197,988, filed Jun. 30, 2016, which is a division of U.S. patent application Ser. No. 14/467,089, filed Aug. 25, 2014, now U.S. Pat. No. 9,381,403, which is a continuation-in-part of U.S. patent application Ser. No. 14/145,648, filed Dec. 31, 2013, now U.S. Pat. No. 9,486,674. U.S. patent application

Ser. No. 14/145,648 is a continuation-in-part of U.S. patent application Ser. No. 14/017,979, filed Sep. 4, 2013, now U.S. Pat. No. 9,327,166, which is a continuation-in-part of U.S. patent application Ser. No. 13/872,354, filed Apr. 29, 2013, now U.S. Pat. No. 9,302,156. U.S. patent application Ser. No. 14/145,648 is also a continuation-in-part of U.S. patent application Ser. No. 13/913,670, filed Jun. 10, 2013, now U.S. Pat. No. 9,126,083; and a continuation-in-part of U.S. patent application Ser. No. 13/611,376, filed Sep. 12, 2012.

**[0005]** U.S. patent application Ser. No. 15/712,267 is also a continuation-in-part of U.S. patent application Ser. No. 14/467,086, filed Aug. 25, 2014, which is a continuation-in-part of U.S. patent application Ser. No. 14/145,633, filed Dec. 31, 2013. U.S. patent application Ser. No. 14/145,633 is a continuation-in-part of U.S. patent application Ser. No. 13/736,993, filed Jan. 9, 2013; U.S. patent application Ser. No. 13/736,997, filed Jan. 9, 2013; U.S. patent application Ser. No. 13/737,026, filed Jan. 9, 2013; and U.S. patent application Ser. No. 13/737,041, filed Jan. 9, 2013. The entire disclosure of every related application cited herein is hereby incorporated herein by reference in its entirety.

**FIELD OF THE INVENTION**

**[0006]** Golf balls having a high coefficient of restitution (CoR) yet reduced flight distance while maintaining the flight trajectory appearance of high CoR golf balls having long flight distance.

**BACKGROUND OF THE INVENTION**

**[0007]** Conventional golf balls can be divided into two general classes: solid and wound. Solid golf balls include one-piece, two-piece (i.e., single layer core and single layer cover), and multi-layer (i.e., solid core of one or more layers and/or a cover of one or more layers) golf balls. Wound golf balls typically include a solid, hollow, or fluid-filled center, surrounded by a tensioned elastomeric material, and a cover.

**[0008]** Examples of golf ball materials span from rubber materials, such as balata, styrene butadiene, polybutadiene, or polyisoprene, to thermoplastic or thermoset resins such as ionomers, polyolefins, polyamides, polyesters, polyurethanes, polyureas and/or polyurethane/polyurea hybrids, and blends thereof. Typically, outer layers are formed about the spherical outer surface of an innermost golf ball layer via compression molding, casting, or injection molding.

**[0009]** Golfers often enjoy honing their skills by practicing on driving ranges, which generally have limited space and often involve hitting a ball into a water body. Golf ball manufacturers therefore seek to develop golf balls that can fly shorter distances at a given swing speed without meanwhile sacrificing the trajectory look of a regular distance golf ball so that a player can predict from shorter practice shots how well the player would likely have done using the regular distance golf ball on the golf course.

**[0010]** In this regard, U.S. Pat. No. 7,938,745 of Sullivan et al. ("745 Patent") and its related applications/patents disclose low coefficient of restitution (CoR) golf balls having a maximum CoR of less than about 0.790 and a reduced flight distance while maintaining the trajectory look of normal flight distance golf balls such as the ProV1 having a higher CoR of 0.807 identified in Tables 8C and 8D of the '745 patent. Unfortunately, golf ball manufacturers have not been able to produce higher CoR golf balls having shorter

flight distance and the flight trajectory look of regular distance high CoR golf balls. A need therefore still remains for high CoR buoyant golf balls that have a flight path with a perceived flight trajectory of regular distance high CoR golf balls even though the flight distance is shorter.

**[0011]** Golf balls of the invention address and solve this need, incorporating dimple patterns which can contribute to producing a flight trajectory that is similar to that of an otherwise identical non-buoyant golf ball. Such golf balls can provide meaningful practice feedback to those golfers using regular high CoR golf balls on the course, and would be particularly desirable if meanwhile producible cost effectively within existing golf ball manufacturing processes.

#### SUMMARY OF THE INVENTION

**[0012]** Accordingly, a buoyant golf ball of the invention has a CoR of at least 0.810, a golf ball specific gravity  $SG_B$  of less than 1.0 g/cc, an initial velocity of at least 250 ft/s, and a dimple pattern with aerodynamic coefficients that are targeted to produce a perceived golf ball flight trajectory of a non-buoyant golf ball of typical non-buoyant golf ball weight (i.e., where the golf ball specific gravity is at or above 1.0 g/cc). Golf balls of the invention can therefore provide valuable feedback to the high CoR golf ball user when taking practice shots in limited spaces, and are especially useful in those spaces containing water bodies, since golf balls of the invention can float.

**[0013]** In one embodiment, a golf ball of the invention has an outer surface with a plurality of dimples disposed thereon, wherein the golf ball has: a coefficient of restitution (CoR) of at least 0.810, a specific gravity of less than 1.00 g/cc, an initial velocity of at least 250 ft/s, a first aerodynamic coefficient magnitude between about 0.25 and about 0.30 and a first aerodynamic force angle between about 29 degrees and 34 degrees at a Reynolds Number of 230000 and a spin ratio of 0.085, and a second aerodynamic coefficient magnitude between about 0.26 and about 0.31 and a second aerodynamic force angle between about 31 degrees and 36 degrees at a Reynolds Number of 180000 and a spin ratio of 0.101.

**[0014]** In a particular such embodiment, the first aerodynamic force angle,  $\theta_{F1}$ , satisfies the condition  $95.4SG_B^2 - 1560.4SG_B + 95 \geq \theta_{F1} \geq 95.4SG_B^2 - 1560.4SG_B + 90$ ; and the second aerodynamic force angle,  $\theta_{F2}$ , satisfies the condition  $95.4SG_B^2 - 1560.4SG_B + 97 \geq \theta_{F2} \geq 95.4SG_B^2 - 1560.4SG_B + 92$ ; wherein  $SG_B$  is the specific gravity of the golf ball in g/cc.

**[0015]** In further embodiment, the golf ball has: a third aerodynamic coefficient magnitude between about 0.27 and about 0.32 and a third aerodynamic force angle between about 34 degrees and 39 degrees at a Reynolds Number of 133000 and a spin ratio of 0.133; and a fourth aerodynamic coefficient magnitude between about 0.33 and about 0.38 and a fourth aerodynamic force angle between about 38 degrees and 43 degrees at a Reynolds Number of 89000 and a spin ratio of 0.183.

**[0016]** In a particular such embodiment, the third aerodynamic force angle,  $\theta_{F3}$ , satisfies the condition  $95.4SG_B^2 - 1560.4SG_B + 100 \geq \theta_{F3} \geq 95.4SG_B^2 - 1560.4SG_B + 95$ ; and the fourth aerodynamic force angle,  $\theta_{F4}$ , satisfies the condition  $95.4SG_B^2 - 1560.4SG_B + 104 \geq \theta_{F4} \geq 95.4SG_B^2 - 1560.4SG_B + 99$ ; wherein  $SG_B$  is the specific gravity of the golf ball in g/cc.

**[0017]** In a specific embodiment, the golf ball may comprise: a first layer  $L_1$  formed from at least one highly

neutralized polymer and having a first specific gravity  $SG_1$  of from 0.95 g/cc to 0.99 g/cc; a second layer  $L_2$  surrounding  $L_1$  and being formed of at least one partially neutralized polymer and having a second specific gravity  $SG_2$ ; and a third layer  $L_3$  surrounding  $L_2$  and being formed from at least one of a thermoset or thermoplastic composition and having a third specific gravity  $SG_3$  of 1.13 g/cc or less; wherein  $SG_1$  is less than or equal to  $SG_3$ .

**[0018]** In another specific embodiment, the golf ball may consist of three layers  $L_1$ ,  $L_2$ , and  $L_3$ ; wherein layer  $L_1$  is formed of at least one rubber and has a first specific gravity  $SG_1$ ; wherein layer  $L_2$  surrounds  $L_1$  and is formed of at least one highly neutralized polymer and has a second specific gravity  $SG_2$ ; and wherein layer  $L_3$  surrounds  $L_2$  and is formed from at least one partially neutralized polymer and has a third specific gravity  $SG_3$ ; wherein at least two of  $SG_1$ ,  $SG_2$ , and  $SG_3$  are less than 1.13 g/cc.

**[0019]** The golf ball may alternatively comprise a first layer  $L_1$ , a second layer  $L_2$  surrounding  $L_1$ , and a third layer  $L_3$  surrounding  $L_2$ , wherein  $L_1$  is formed from at least one highly neutralized polymer and has a first specific gravity  $SG_1$ ;  $L_2$  is formed of at least one partially neutralized polymer and has a second specific gravity  $SG_2$ ; and  $L_3$  is formed from at least one of a thermoset or thermoplastic composition and has a third specific gravity  $SG_3$ . At least two of  $SG_1$ ,  $SG_2$ , and  $SG_3$  is less than 1.13 g/cc. In a particular embodiment,  $SG_1$  is less than 1.13 g/cc. In a specific such embodiment,  $SG_1$  is less than 1.0 g/cc. The thermoset or thermoplastic composition may comprise polyurethane(s), polyurea(s), polyurethane(s)/polyurea(s) hybrids, and/or ionomers such as at least partially neutralized polymers and/or HNPs.

**[0020]** In another embodiment, the golf ball may have a CoR of greater than 0.810. In yet another embodiment, the golf ball may have a CoR of at least 0.820. In still another embodiment, the golf ball may have a CoR of at least 0.830. In other embodiments, the golf ball may have a CoR of at least 0.840.

**[0021]** In one embodiment, a  $\Delta SG$  (i.e., a specific gravity difference or gradient) between each of  $SG_1$ ,  $SG_2$ , and  $SG_3$  is no greater than 0.50. In another embodiment,  $\Delta SG$  between each of  $SG_1$ ,  $SG_2$ , and  $SG_3$  may be from 0.05 to 0.30. In yet another embodiment,  $\Delta SG$  between each of  $SG_1$ ,  $SG_2$ , and  $SG_3$  may be up to 0.20.

**[0022]** In still another embodiment, at least one of  $SG_1$ ,  $SG_2$ ,  $SG_3$  is greater than 1.00 g/cc. In a specific embodiment,  $SG_1$  and  $SG_2$  are less than 1.00 g/cc and  $SG_3$  is less than 1.15 g/cc.

**[0023]**  $SG_1$  and  $SG_2$  may be substantially similar. In some embodiments,  $SG_1$  and  $SG_2$  differ. In one embodiment,  $SG_1$  and  $SG_3$  may differ. In a particular embodiment,  $SG_3$  may be different than  $SG_1$  and  $SG_2$ .

**[0024]** In one embodiment,  $SG_B$  is from about 0.8 g/cc to about 0.99 g/cc. In another embodiment,  $SG_B$  may be from about 0.9 g/cc to about 0.99 g/cc.

**[0025]** The initial velocity may in some embodiments be at least about 253 ft/s, or even greater than 254 ft/s.

**[0026]** In a particular embodiment,  $L_1$  has a specific gravity of less than 1.0,  $L_2$  has a CoR of at least 0.810; and the finished golf ball has a CoR of at least 0.810. In one such embodiment, a  $\Delta SG$  between  $SG_1$  and  $SG_B$  is less than 0.17.

**[0027]** The golf ball may in some embodiments have a diameter of 1.70 inches or greater, with the at least one highly neutralized polymer of  $L_1$  being foamed, and  $L_1$

having a diameter of 1.30 inches or greater. In a particular such embodiment,  $L_3$  may meanwhile have a thickness that is greater than a thickness of  $L_2$ .

**[0028]** In another embodiment,  $SG_2$  may be less than 1.0 g/cc and greater than  $SG_1$ , while  $SG_3$  is greater than 1.0 g/cc.

**[0029]** In a specific embodiment, the highly neutralized polymer of  $L_1$  may be blended with an ionomer of ethylene acid acrylate terpolymer, and the partially neutralized polymer of  $L_2$  may be a blend of ionomers.

**[0030]** In some embodiments, the golf ball may have a diameter of 1.70 inches or greater.

**[0031]** In one embodiment, the difference in Shore C hardness between a center of  $L_1$  and an outer surface of  $L_1$  may be from 0 to 8 hardness points.

**[0032]** The golf ball may have a compression of at least 70.

**[0033]** In one specific embodiment,  $L_1$  comprises a core having a diameter of at least 1.7 inches,  $L_2$  comprises an inner cover layer; and  $L_3$  comprises an outer cover layer; wherein the golf ball has a diameter of greater than 1.80 inches.

**[0034]** In another embodiment of a golf ball of the invention has a CoR of at least 0.810, a specific gravity  $SG_B$  of less than 1.00 g/cc, and an initial velocity of at least 250 ft/s, and  $L_1$  is formed of at least one rubber and has a second specific gravity  $SG_1$ ;  $L_2$  is formed of at least one highly neutralized polymer and has a second specific gravity  $SG_2$ ; and  $L_3$  is formed from at least one of a thermoset or thermoplastic composition and has a third specific gravity  $SG_3$ . At least two of  $SG_1$ ,  $SG_2$ , and  $SG_3$  is less than 1.13 g/cc. The difference in Shore C hardness between a center of  $L_1$  and an outer surface of  $L_1$  may be from 0 to 8 hardness points; or greater than 8 and up to 22 hardness points; or greater than 22 hardness points. The thermoset or thermoplastic composition may comprise polyurethane(s), polyurea(s), polyurethane(s)/polyurea(s) hybrids, and/or ionomers such as at least partially neutralized polymers and/or HNPs.

**[0035]** A golf ball of the invention may be formed cost effectively using existing golf ball manufacturing equipment and processes. The method of making a golf ball of the invention may comprise forming at least one highly neutralized polymer into a first layer  $L_1$  having a first specific gravity  $SG_1$ ; forming at least one partially neutralized polymer into a second layer  $L_2$  having a second specific gravity  $SG_2$  about  $L_1$ ; forming at least one of a thermoset or thermoplastic composition into a third layer  $L_3$  having third specific gravity  $SG_3$  about  $L_2$ ; such that at least two of  $SG_1$ ,  $SG_2$ , and  $SG_3$  is less than 1.13 g/cc. and the golf ball has a specific gravity  $SG_B$  of less than 1.00 g/cc, and an initial velocity of at least 250 ft/s, and the resulting golf ball has a CoR of at least 0.810, or greater than 0.810, or at least 0.820, or 0.830 or greater. The thermoset or thermoplastic composition may comprise polyurethane(s), polyurea(s), polyurethane(s)/polyurea(s) hybrids, and/or ionomers such as at least partially neutralized polymers and/or HNPs.

**[0036]** In a different embodiment, the method of making a golf ball of the invention may comprise forming at least one rubber into a first layer  $L_1$  having a first specific gravity  $SG_1$ ; forming at least one partially neutralized polymer into a second layer  $L_2$  having a second specific gravity  $SG_2$  about  $L_1$ ; forming at least one of a thermoset or thermoplastic composition into a third layer  $L_3$  having third specific gravity  $SG_3$  about  $L_2$ ; such that the golf ball has a specific gravity  $SG_B$  of less than 1.00 g/cc, and an initial velocity of

at least 250 ft/s, and the resulting golf ball has a CoR of at least 0.810, or greater than 0.810, or at least 0.820, or 0.830 or greater.

**[0037]** The thermoset or thermoplastic composition may comprise polyurethane(s), polyurea(s), polyurethane(s)/polyurea(s) hybrids, and/or ionomers such as at least partially neutralized polymers and/or HNPs.

**[0038]** In a particular embodiment, a golf ball of the invention comprises a core and a cover, wherein the core has an overall diameter of from 1.40 inches to 1.60 inches and comprises a center  $L_1$  and an outer core layer  $L_2$ .  $L_1$  has a diameter of from 0.50 inches to 1.50 inches, a surface hardness of 65 Shore C or greater, a center hardness (H), and is formed from at least one highly neutralized polymer composition having a material hardness of 55 Shore D or less and comprising a highly neutralized ethylene/(meth)acrylic acid/alkyl (meth)acrylate copolymer wherein at least 80% of the acid groups of the acid copolymer are neutralized. Meanwhile,  $L_1$  has a first specific gravity  $SG_1$ .

**[0039]**  $L_2$  surrounds  $L_1$  and is formed of at least one partially neutralized polymer having a surface hardness (S) of from 20 Shore C to 90 Shore C. The partially neutralized polymer composition has a material hardness of 45 Shore D or greater and comprises a partially neutralized ethylene/(meth)acrylic acid copolymer wherein 40% to 100% of the acid groups of the acid copolymer are neutralized. Meanwhile,  $L_2$  has a second specific gravity  $SG_2$ .

**[0040]** A third layer  $L_3$  surrounds  $L_2$  and is formed from at least one of a thermoset or thermoplastic composition and has a third specific gravity  $SG_3$ . For example,  $L_3$  may be formed from polyurethane(s), polyurea(s), polyurethane(s)/polyurea(s) hybrids, and/or ionomers such as at least partially neutralized polymers and/or HNPs.

**[0041]** Additionally,  $S-H=D$ , where D is an integer from 1 to 22; and the material hardness of the highly neutralized composition used to form  $L_1$  is less than the material hardness of the partially neutralized composition used to form  $L_2$ ; and at least two of  $SG_1$ ,  $SG_2$ , and  $SG_3$  is less than 1.13 g/cc; and the golf ball has a specific gravity  $SG_B$  of less than 1.00 g/cc and an initial velocity of at least 250 ft/s, and the resulting golf ball has a CoR of at least 0.810, or greater than 0.810, or at least 0.820, or 0.830 or greater.

#### BRIEF DESCRIPTION OF THE DRAWINGS

**[0042]** FIG. 1 is a cross-sectional view of a golf ball according to one embodiment of the present invention; and

**[0043]** FIG. 2 is a cross-sectional view of a golf ball of the invention according to a different embodiment.

#### DETAILED DESCRIPTION OF THE INVENTION

**[0044]** A golf ball of the invention has a specific gravity of less than 1.0 g/cc and is therefore buoyant with a golf ball weight that is lower than the weight of an otherwise identical non-buoyant golf ball having a specific gravity at or above 1.0 g/cc. This lower weight results in higher golf ball flight, shorter golf ball distance, and a different flight trajectory than that of the golf ball having a specific gravity at or above 1.0 g/cc. Golf balls of the invention incorporate dimples having aerodynamic coefficient magnitudes and the aerodynamic force angles which can contribute to producing a flight trajectory that is similar to that of an otherwise

identical non-buoyant golf ball due at least in part to the golf ball's reduced aerodynamic coefficient magnitude and aerodynamic force angle.

[0045] In this regard, the aerodynamic coefficient magnitude and the aerodynamic force angle can describe the aerodynamic characteristics of a golf ball. The aerodynamic coefficient magnitude is defined by:

$$C_{mag} = \sqrt{C_L^2 + C_D^2},$$

while the aerodynamic force angle is defined by, for example:

$$\theta_F = \tan^{-1}\left(\frac{C_L}{C_D}\right).$$

[0046] In both of these equations  $C_L$  is the lift coefficient, and  $C_D$  is the drag coefficient. The aerodynamic coefficient magnitude and aerodynamic force angle account for both lift and drag simultaneously, and are described in U.S. Pat. No. 6,729,976, the entirety of which is incorporated herein.

[0047] In one embodiment, a golf ball of the invention has an outer surface with a plurality of dimples disposed thereon, wherein the golf ball has: a coefficient of restitution (CoR) of at least 0.810, a specific gravity of less than 1.00 g/cc, an initial velocity of at least 250 ft/s, a first aerodynamic coefficient magnitude between about 0.25 and about 0.30 and a first aerodynamic force angle between about 29 degrees and 34 degrees at a Reynolds Number of 230000 and a spin ratio of 0.085, and a second aerodynamic coefficient magnitude between about 0.26 and about 0.31 and a second aerodynamic force angle between about 31 degrees and 36 degrees at a Reynolds Number of 180000 and a spin ratio of 0.101.

[0048] In a particular such embodiment, the first aerodynamic force angle,  $\theta_{F1}$ , satisfies the condition  $95.4SG_B - 1560.4SG_B + 95 \geq \theta_{F1} \geq 95.4SG_B - 1560.4SG_B + 90$ ; and the second aerodynamic force angle,  $\theta_{F2}$ , satisfies the condition  $95.4SG_B - 1560.4SG_B + 97 \geq \theta_{F2} \geq 95.4SG_B - 1560.4SG_B + 92$ ; wherein  $SG_B$  is the specific gravity of the golf ball in g/cc.

[0049] In further embodiment, the golf ball has: a third aerodynamic coefficient magnitude between about 0.27 and about 0.32 and a third aerodynamic force angle between about 34 degrees and 39 degrees at a Reynolds Number of 133000 and a spin ratio of 0.133; and a fourth aerodynamic coefficient magnitude between about 0.33 and about 0.38 and a fourth aerodynamic force angle between about 38 degrees and 43 degrees at a Reynolds Number of 89000 and a spin ratio of 0.183.

[0050] In a particular such embodiment, the third aerodynamic force angle,  $\theta_{F3}$ , satisfies the condition  $95.4SG_B^2 - 1560.4SG_B + 100 \geq \theta_{F3} \geq 95.4SG_B^2 - 1560.4SG_B + 95$ ; and the fourth aerodynamic force angle,  $\theta_{F4}$ , satisfies the condition  $95.4SG_B^2 - 1560.4SG_B + 104 \geq \theta_{F4} \geq 95.4SG_B^2 - 1560.4SG_B + 99$ ; wherein  $SG_B$  is the specific gravity of the golf ball in g/cc.

[0051] In a specific embodiment, the golf ball may comprise: a first layer  $L_1$  formed from at least one highly neutralized polymer and having a first specific gravity  $SG_1$  of from 0.95 g/cc to 0.99 g/cc; a second layer  $L_2$  surrounding  $L_1$  and being formed of at least one partially neutralized polymer and having a second specific gravity  $SG_2$ ; and a third layer  $L_3$  surrounding  $L_2$  and being formed from at least

one of a thermoset or thermoplastic composition and having a third specific gravity  $SG_3$  of 1.13 g/cc or less; wherein  $SG_1$  is less than or equal to  $SG_3$ .

[0052] In another specific embodiment, the golf ball may consist of three layers  $L_1$ ,  $L_2$ , and  $L_3$ ; wherein layer  $L_1$  is formed of at least one rubber and has a first specific gravity  $SG_1$ ; wherein layer  $L_2$  surrounds  $L_1$  and is formed of at least one highly neutralized polymer and has a second specific gravity  $SG_2$ ; and wherein layer  $L_3$  surrounds  $L_2$  and is formed from at least one partially neutralized polymer and has a third specific gravity  $SG_3$ ; wherein at least two of  $SG_1$ ,  $SG_2$ , and  $SG_3$  are less than 1.13 g/cc.

[0053] The numbers disclosed in each embodiment herein for aerodynamic coefficient magnitude and aerodynamic force angle reflect the averages from lift and drag values obtained when 12 balls are tested in a random orientation.

[0054] The Reynolds number is an average value for the test and can vary by  $\pm 3\%$ , the Spin Ratio is an average value and can vary by  $\pm 5\%$ .

[0055] FIG. 1 shows a golf ball 30 according to one embodiment of the present invention, including a center 32, an intermediate core layer 34, an outer core layer 36, and a cover 38. While shown in FIG. 1 as a single layer, cover 38 may be a single-, dual-, or multi-layer cover. Advantageously, a golf ball of the invention has a high CoR of at least 0.810 yet achieves a shorter flight distance with the perceived flight trajectory look of a normal/regular distance high CoR golf ball. Golf balls of the invention can therefore provide valuable feedback to the high CoR golf ball user when taking practice shots in limited spaces, and are particularly beneficial in those spaces containing water bodies, since golf balls of the invention float.

[0056] Referring to FIG. 2, in one embodiment, golf ball 100 consists of first layer 120 formed of at least one rubber and having a first specific gravity  $SG_1$ ; second layer 140 surrounding first layer 120 and being formed of at least one highly neutralized polymer and having a second specific gravity  $SG_2$ ; and third layer 160 surrounding second layer 140 and being formed from at least one partially neutralized polymer and having a third specific gravity  $SG_3$ ; wherein at least two of  $SG_1$ ,  $SG_2$ , and  $SG_3$  is less than 1.13 g/cc; and wherein the golf ball has a coefficient of restitution (CoR) of at least 0.810, a specific gravity  $SG_B$  of less than 1.00 g/cc and an initial velocity of at least 250 ft/s.

[0057] Accordingly, a golf ball of the invention has a CoR of at least 0.810, a golf ball specific gravity of less than 1.0 g/cc, an initial velocity of at least 250 ft/s, and comprises at least three layers wherein at least two of the layers have a specific gravity less than 1.13 g/cc.

[0058] In a preferred embodiment, the innermost layer of the three layers has a specific gravity less than 1.13 g/cc, or less than 1.12 g/cc, and more preferably, less than 1.0 g/cc. The resulting golf ball is meanwhile lightweight and buoyant and therefore particularly useful on practice ranges containing water bodies.

[0059] In another embodiment, the golf ball may have a CoR of greater than 0.810. In yet another embodiment, the golf ball may have a CoR of at least 0.820. In still another embodiment, the golf ball has a CoR of at least 0.830. The golf ball may have a CoR of at least 0.840 as well.

[0060] In one embodiment, a golf ball of the invention comprises a first layer  $L_1$ , a second layer  $L_2$  surrounding  $L_1$ , and a third layer  $L_3$  surrounding  $L_2$ .  $L_1$  is formed from at least one highly neutralized polymer and has a first specific



gravity  $SG_1$ ;  $L_2$  is formed of at least one partially neutralized polymer and has a second specific gravity  $SG_2$ ; and  $L_3$  is formed from at least one of a thermoset or thermoplastic composition and has a third specific gravity  $SG_3$ . The thermoset or thermoplastic composition may comprise polyurethane(s), polyurea(s), polyurethane(s)/polyurea(s) hybrids, and/or ionomers such as at least partially neutralized polymers and/or HNPs.

**[0061]** In one embodiment a  $\Delta SG$  (i.e., a specific gravity difference or gradient) between each of  $SG_1$ ,  $SG_2$ , and  $SG_3$  is no greater than 0.50. In another embodiment,  $\Delta SG$  between each of  $SG_1$ ,  $SG_2$ , and  $SG_3$  is from 0.05 to 0.30. In yet another embodiment, a  $\Delta SG$  between each of  $SG_1$ ,  $SG_2$ , and  $SG_3$  is up to 0.20. In still another embodiment, a  $\Delta SG$  between at least two of  $SG_1$ ,  $SG_2$ , and  $SG_3$  is less than 0.17.

**[0062]** In still another embodiment, at least one of  $SG_1$ ,  $SG_2$ ,  $SG_3$  is greater than 1.00 g/cc. In a specific embodiment,  $SG_1$  and  $SG_2$  are less than 1.00 g/cc and  $SG_3$  is less than 1.15 g/cc.

**[0063]**  $SG_1$  and  $SG_2$  may be substantially similar. In some embodiments,  $SG_1$  and  $SG_2$  differ. In one embodiment,  $SG_1$  and  $SG_3$  may differ. In a particular embodiment,  $SG_3$  may be different than  $SG_1$  and  $SG_2$ .

**[0064]** In one embodiment,  $SG_B$  is from about 0.8 g/cc to about 0.99 g/cc. In another embodiment,  $SG_B$  may be from about 0.9 g/cc to about 0.99 g/cc. However, it is envisioned that  $SG_B$  may be any value less than 1.0 g/cc which, in a golf ball having a CoR of at least 0.810 and having an initial velocity of at least 250 ft/s, can achieve reduced distance yet simulated flight trajectory compared with a regular distance golf ball having a CoR of 0.810 or other high CoR golf ball.

**[0065]** The initial velocity may in some embodiments be at least about 253 ft/s, or at least 254 ft/s, or at least 255 ft/s, or at least 256 ft/s, or at least 257 ft/s, or even at least 258 ft/s.

**[0066]** In a particular embodiment,  $L_1$  has a specific gravity of less than 1.0,  $L_2$  has a CoR of at least 0.810; and the finished golf ball has a CoR of at least 0.810. In one such embodiment, a  $\Delta SG$  between  $SG_1$  and  $SG_B$  is less than 0.17.

**[0067]** In a different embodiment, the golf ball has a diameter of 1.70 inches or greater, the at least one highly neutralized polymer of  $L_1$  is foamed, and  $L_1$  has a diameter of 1.30 inches or greater. In a particular such embodiment,  $L_3$  may meanwhile have a thickness that is greater than a thickness of  $L_2$ .

**[0068]** In another embodiment,  $SG_2$  may be less than 1.0 g/cc and greater than  $SG_1$ , and  $SG_3$  is greater than 1.0 g/cc.

**[0069]** In a specific embodiment, the highly neutralized polymer of  $L_1$  is blended with an ionomer of ethylene acid acrylate terpolymer, and the partially neutralized polymer of  $L_2$  is a blend of ionomers.

**[0070]** In some embodiments, the golf ball may have a diameter of 1.70 inches or greater.

**[0071]** In one embodiment, the difference in Shore C hardness between a center of  $L_1$  and an outer surface of  $L_1$  may be from 0 to 8 hardness points.

**[0072]** The golf ball may have a compression of at least 70.

**[0073]** In one specific embodiment,  $L_1$  comprises a core having a diameter of at least 1.7 inches,  $L_2$  comprises an inner cover layer; and  $L_3$  comprises an outer cover layer; wherein the golf ball has a diameter of greater than 1.80 inches.

**[0074]** In another embodiment of a golf ball of the invention,  $L_1$  is formed of at least one rubber and has a first specific gravity  $SG_1$ ;  $L_2$  is formed of at least one highly neutralized polymer and has a second specific gravity  $SG_2$ ; and  $L_3$  is formed from at least one at least one of thermoset or thermoplastic composition and has a third specific gravity  $SG_3$  which may have any value defined herein for a layer  $L_3$ . The thermoset or thermoplastic composition may comprise polyurethane(s), polyurea(s), polyurethane(s)/polyurea(s) hybrids, and/or ionomers such as at least partially neutralized polymers and/or HNPs.

**[0075]** In this embodiment, the difference in Shore C hardness between a center of  $L_1$  and an outer surface of  $L_1$  may be from 0 to 8 hardness points; or greater than 8 and up to 22 hardness points; or greater than 22 hardness points. In a particular embodiment, the at least one at least one of a thermoset or thermoplastic composition comprises at least one partially neutralized polymer.

**[0076]** A golf ball of the invention may be formed cost effectively using existing golf ball manufacturing equipment using the method of then invention. The method of making a golf ball of the invention may comprise forming at least one highly neutralized polymer into a first layer  $L_1$  having a first specific gravity  $SG_1$ ; forming at least one partially neutralized polymer into a second layer  $L_2$  having a second specific gravity  $SG_2$  about  $L_1$ ; forming at least one of a thermoset or thermoplastic composition into a third layer  $L_3$  having third specific gravity  $SG_3$  about  $L_2$ ; such that the golf ball has a specific gravity  $SG_B$  of less than 1.00 g/cc, and an initial velocity of at least 250 ft/s, and has a CoR of at least 0.810, or greater than 0.810, or at least 0.820, or at least 0.830, or even 0.840 or greater. The thermoset or thermoplastic composition may comprise polyurethane(s), polyurea (s), polyurethane(s)/polyurea(s) hybrids, and/or ionomers such as at least partially neutralized polymers and/or HNPs.

**[0077]** In a different embodiment, the method of making a golf ball of the invention may comprise forming at least one rubber into a first layer  $L_1$  having a first specific gravity  $SG_1$ ; forming at least one partially neutralized polymer into a second layer  $L_2$  having a second specific gravity  $SG_2$  about  $L_1$ ; forming at least one of a thermoset or thermoplastic composition into a third layer  $L_3$  having third specific gravity  $SG_3$  about  $L_2$ ; such that the golf ball has a specific gravity  $SG_B$  of less than 1.00 g/cc, and an initial velocity of at least 250 ft/s and has a CoR of at least 0.810, or greater than 0.810, or at least 0.820, or at least 0.830, or even 0.840 or greater. The thermoset or thermoplastic composition may comprise polyurethane(s), polyurea(s), polyurethane(s)/polyurea(s) hybrids, and/or ionomers such as at least partially neutralized polymers and/or HNPs.

**[0078]** In a particular embodiment, a golf ball of the invention comprises a core and a cover, wherein the core has an overall diameter of from 1.40 inches to 1.60 inches and comprises a center  $L_1$  and an outer core layer  $L_2$ .  $L_1$  has a diameter of from 0.50 inches to 1.50 inches, a surface hardness of 65 Shore C or greater, a center hardness (H), and is formed from at least one highly neutralized polymer composition having a material hardness of 55 Shore D or less and comprising a highly neutralized ethylene/(meth)acrylic acid/alkyl (meth)acrylate copolymer wherein at least 80% of the acid groups of the acid copolymer are neutralized. Meanwhile,  $L_1$  has a first specific gravity  $SG_1$ .

**[0079]**  $L_2$  surrounds  $L_1$  and is formed of at least one partially neutralized polymer having a surface hardness (S)

of from 20 Shore C to 70 Shore C. The partially neutralized polymer composition has a material hardness of 45 Shore D or greater and comprises a partially neutralized ethylene/(meth)acrylic acid copolymer wherein 40% to 100% of the acid groups of the acid copolymer are neutralized. Meanwhile,  $L_2$  has a second specific gravity  $SG_2$ .

**[0080]** A third layer  $L_3$  surrounds  $L_2$  and is formed from at least one of a thermoset or thermoplastic composition and has a third specific gravity  $SG_3$ . The thermoset or thermoplastic composition may comprise polyurethane(s), polyurea(s), polyurethane(s)/polyurea(s) hybrids, and/or ionomers such as at least partially neutralized polymers and/or HNPs.

**[0081]** Additionally,  $S-H=D$ , where  $D$  is an integer from 1 to 22; and the material hardness of the highly neutralized composition used to form  $L_1$  is less than the material hardness of the partially neutralized composition used to form  $L_2$ ; and the golf ball has a specific gravity  $SG_B$  of less than 1.00 g/cc and an initial velocity of at least 250 ft/s, and has a CoR of at least 0.810, or greater than 0.810, or at least 0.820, or at least 0.830, or even 0.840 or greater.

**[0082]** For each embodiment above, it is envisioned that  $L_3$  may comprise polyurethane(s), polyurea(s), polyurethane/polyurea hybrids, and/or ionomers including partially and highly neutralized polymers.

**[0083]** Golf balls of the present invention may incorporate at least one layer formed from a highly neutralized acid polymer (“HNP”) composition, including relatively soft, or low modulus, HNP compositions and relatively hard, or high modulus, HNP compositions, or blends thereof.

**[0084]** As used herein, “highly neutralized acid polymer” refers to an acid polymer after at least 80%, preferably at least 90%, more preferably at least 95%, and even more preferably 100%, of the acid groups of the acid polymer are neutralized.

**[0085]** As used herein, “modulus” refers to flexural modulus as measured using a standard flex bar according to ASTM D790-B.

**[0086]** For purposes of the present disclosure, material hardness is measured according to ASTM D2240 and generally involves measuring the hardness of a flat “slab” or “button” formed of the material. It should be understood that there is a fundamental difference between “material hardness” and “hardness as measured directly on a golf ball.” Hardness as measured directly on a golf ball (or other spherical surface) typically results in a different hardness value than material hardness. This difference in hardness values is due to several factors including, but not limited to, ball construction (i.e., core type, number of core and/or cover layers, etc.), ball (or sphere) diameter, and the material composition of adjacent layers. It should also be understood that the two measurement techniques are not linearly related and, therefore, one hardness value cannot easily be correlated to the other. Unless stated otherwise, the hardness values given herein for cover materials are material hardness values measured according to ASTM D2240, with all values reported following 10 days of aging at 50% relative humidity and 23° C.

**[0087]** The surface hardness of a golf ball layer is obtained from the average of a number of measurements taken from opposing hemispheres of a core, taking care to avoid making measurements on the parting line of the core or on surface defects, such as holes or protrusions. Hardness measurements are made pursuant to ASTM D-2240 “Indentation Hardness of Rubber and Plastic by Means of a Durometer.”

Because of the curved surface of a core, care must be taken to insure that the golf ball or golf ball subassembly is centered under the durometer indenter before a surface hardness reading is obtained. A calibrated, digital durometer, capable of reading to 0.1 hardness units is used for all hardness measurements and is set to take hardness readings at 1 second after the maximum reading is obtained. The digital durometer must be attached to, and its foot made parallel to, the base of an automatic stand, such that the weight on the durometer and attack rate conform to ASTM D-2240.

**[0088]** The center hardness of a core is obtained according to the following procedure. The core is gently pressed into a hemispherical holder having an internal diameter approximately slightly smaller than the diameter of the core, such that the core is held in place in the hemispherical portion of the holder while concurrently leaving the geometric central plane of the core exposed. The core is secured in the holder by friction, such that it will not move during the cutting and grinding steps, but the friction is not so excessive that distortion of the natural shape of the core would result. The core is secured such that the parting line of the core is roughly parallel to the top of the holder. The diameter of the core is measured 90 degrees to this orientation prior to securing. A measurement is also made from the bottom of the holder to the top of the core to provide a reference point for future calculations. A rough cut, made slightly above the exposed geometric center of the core using a band saw or other appropriate cutting tool, making sure that the core does not move in the holder during this step. The remainder of the core, still in the holder, is secured to the base plate of a surface grinding machine. The exposed ‘rough’ surface is ground to a smooth, flat surface, revealing the geometric center of the core, which can be verified by measuring the height of the bottom of the holder to the exposed surface of the core, making sure that exactly half of the original height of the core, as measured above, has been removed to within  $\pm 0.004$  inches. Leaving the core in the holder, the center of the core is found with a center square and carefully marked and the hardness is measured at the center mark.

**[0089]** Golf ball layers of the present invention may have a zero or negative or positive hardness gradient. A hardness gradient is defined by hardness measurements made at the surface of the layer (e.g., center, outer core layer, etc.) and radially inward towards the center of the ball, typically at 2 mm increments. For purposes of the present invention, “negative” and “positive” refer to the result of subtracting the hardness value at the innermost portion of the golf ball component from the hardness value at the outer surface of the component. For example, if the outer surface of a solid core has a lower hardness value than the center (i.e., the surface is softer than the center), the hardness gradient will be deemed a “negative” gradient. In measuring the hardness gradient of a core, the center hardness is first determined according to the procedure above for obtaining the center hardness of a core. Once the center of the core is marked and the hardness thereof is determined, hardness measurements at any distance from the center of the core may be measured by drawing a line radially outward from the center mark, and measuring and marking the distance from the center, typically in 2 mm increments. All hardness measurements performed on a plane passing through the geometric center are performed while the core is still in the holder and without having disturbed its orientation, such that the test surface is

constantly parallel to the bottom of the holder. The hardness difference from any predetermined location on the core is calculated as the average surface hardness minus the hardness at the appropriate reference point, e.g., at the center of the core for a single, solid core, such that a core surface softer than its center will have a negative hardness gradient. Hardness gradients are disclosed more fully, for example, in U.S. patent application Ser. No. 11/832,163, filed on Aug. 1, 2007; Ser. No. 11/939,632, filed on Nov. 14, 2007; Ser. No. 11/939,634, filed on Nov. 14, 2007; Ser. No. 11/939,635, filed on Nov. 14, 2007; and Ser. No. 11/939,637, filed on Nov. 14, 2007; the entire disclosure of each of these references is hereby incorporated herein by reference.

#### Relatively Soft/Low Modulus HNP Compositions

**[0090]** Relatively soft HNP compositions of the present invention have a material hardness of 80 Shore D or less, and preferably have a Shore D hardness of 55 or less or a Shore D hardness within the range having a lower limit of 10 or 20 or 30 or 37 or 39 or 40 or 45 and an upper limit of 48 or 50 or 52 or 55 or 60 or 80. Alternatively, soft HNP compositions of the present invention have a material hardness within a range having a lower limit of 30 or 40 or 45 Shore C and an upper limit of 55 or 60 or 80 Shore C.

**[0091]** Low modulus HNP compositions of the present invention comprise at least one low modulus HNP having a modulus within a range having a lower limit of 1,000 or 5,000 or 10,000 psi and an upper limit of 17,000 or 25,000 or 28,000 or 30,000 or 35,000 or 45,000 or 50,000 or 55,000 psi. In a preferred embodiment, the modulus of the low modulus HNP is at least 10% less, or at least 20% less, or at least 25% less, or at least 30% less, or at least 35% less, than the modulus of the high modulus HNP.

**[0092]** Relatively soft HNP compositions of the present invention comprise at least one highly neutralized acid polymer. In a preferred embodiment, the highly neutralized acid polymer of the relatively soft HNP composition is a low modulus HNP having a modulus within a range having a lower limit of 1,000 or 5,000 or 10,000 psi and an upper limit of 17,000 or 25,000 or 28,000 or 30,000 or 35,000 or 45,000 or 50,000 or 55,000 psi. In a particular aspect of this embodiment, the modulus of the low modulus HNP is at least 10% less, or at least 20% less, or at least 25% less, or at least 30% less, or at least 35% less, than that of the high modulus HNP discussed below.

**[0093]** HNPs of the relatively soft/low modulus HNP compositions of the present invention are salts of acid copolymers. It is understood that the HNP may be a blend of two or more HNPs. The acid copolymer of the HNP is an O/X/Y-type copolymer, wherein O is an  $\alpha$ -olefin, X is a  $C_3$ - $C_8$   $\alpha,\beta$ -ethylenically unsaturated carboxylic acid, and Y is a softening monomer. O is preferably ethylene. X is preferably selected from (meth) acrylic acid, ethacrylic acid, maleic acid, crotonic acid, fumaric acid, and itaconic acid. (Meth) acrylic acid is particularly preferred. As used herein, "(meth) acrylic acid" means methacrylic acid and/or acrylic acid. Likewise, "(meth) acrylate" means methacrylate and/or acrylate. Y is preferably an alkyl (meth) acrylate, wherein the alkyl groups have from 1 to 8 carbon atoms. Preferred O/X/Y-type copolymers are those wherein O is ethylene, X is (meth) acrylic acid, and Y is selected from (meth) acrylate, n-butyl (meth) acrylate, isobutyl (meth) acrylate, methyl (meth) acrylate, and ethyl (meth) acrylate. Particularly preferred O/X/Y-type copolymers are ethylene/(meth) acrylic

acid/n-butyl acrylate, ethylene/(meth) acrylic acid/methyl acrylate, and ethylene/(meth) acrylic acid/ethyl acrylate.

**[0094]** The acid copolymer of the HNP typically includes the  $\alpha$ -olefin in an amount of at least 15 wt %, or at least 25 wt %, or at least 40 wt %, or at least 60 wt %, based on the total weight of the acid copolymer. The amount of  $C_3$ - $C_8$   $\alpha,\beta$ -ethylenically unsaturated carboxylic acid in the acid copolymer is typically within a range having a lower limit of 1 or 2 or 4 or 6 or 8 or 10 or 12 or 15 or 16 or 20 wt % and an upper limit of 20 or 25 or 26 or 30 or 35 or 40 wt %, based on the total weight of the acid copolymer. The amount of optional softening monomer in the acid copolymer is typically within a range having a lower limit of 0 or 1 or 3 or 5 or 11 or 15 or 20 wt % and an upper limit of 23 or 25 or 30 or 35 or 50 wt %, based on the total weight of the acid copolymer.

**[0095]** Particularly suitable acid copolymers of the HNP of the relatively soft/low modulus HNP composition include very low modulus ionomer- ("VLMI-") type ethylene-acid polymers, such as Surlyn® 6320, Surlyn® 8120, Surlyn® 8320, and Surlyn® 9320. Surlyn® ionomers are commercially available from E. I. du Pont de Nemours and Company. Also suitable are DuPont® HPF 1000, HPF 2000, HPF AD 1035, HPF AD 1040, ionomeric materials commercially available from E. I. du Pont de Nemours and Company.

**[0096]** Additional suitable acid copolymers are disclosed, for example, in U.S. Patent Application Publication Nos. 2005/0148725, 2005/0020741, 2004/0220343, and 2003/0130434, and U.S. Pat. Nos. 5,691,418, 6,562,906, 6,653,382, 6,777,472, 6,762,246, and 6,815,480, the entire disclosures of which are hereby incorporated herein by reference.

**[0097]** In a preferred embodiment, the HNP of the relatively soft/low modulus HNP composition is formed by reacting an acid copolymer, which is optionally partially neutralized, with a sufficient amount of cation source, in the presence of a high molecular weight organic acid or salt thereof, such that at least 80%, preferably at least 90%, more preferably at least 95%, and even more preferably 100%, of all acid groups present are neutralized. In a particular embodiment, the cation source is present in an amount sufficient to neutralize, theoretically, greater than 100%, or 105% or greater, or 110% or greater, or 115% or greater, or 120% or greater, or 125% or greater, or 200% or greater, or 250% or greater of all acid groups present in the composition. The acid copolymer can be reacted with the high molecular weight organic acid or salt thereof and the cation source simultaneously, or the acid copolymer can be reacted with the high molecular weight organic acid prior to the addition of the cation source.

**[0098]** Suitable high molecular weight organic acids are aliphatic organic acids, aromatic organic acids, saturated monofunctional organic acids, unsaturated monofunctional organic acids, multi-unsaturated monofunctional organic acids, and dimerized derivatives thereof. Particular examples of suitable organic acids include, but are not limited to, caproic acid, caprylic acid, capric acid, lauric acid, stearic acid, behenic acid, erucic acid, oleic acid, linoleic acid, myristic acid, benzoic acid, palmitic acid, phenylacetic acid, naphthalenoic acid, dimerized derivatives thereof, and combinations thereof. Salts of high molecular weight organic acids comprise the salts, particularly the barium, lithium, sodium, zinc, bismuth, chromium, cobalt, copper, potassium, stontium, titanium, tungsten, magnesium, and calcium salts, of aliphatic organic acids, aromatic

organic acids, saturated monofunctional organic acids, unsaturated monofunctional organic acids, multi-unsaturated monofunctional organic acids, dimerized derivatives thereof, and combinations thereof. Suitable organic acids and salts thereof are more fully described, for example, in U.S. Pat. No. 6,756,436, the entire disclosure of which is hereby incorporated herein by reference.

**[0099]** Suitable cation sources include metal ions and compounds of alkali metals, alkaline earth metals, and transition metals; metal ions and compounds of rare earth elements; silicone, silane, and silicate derivatives and complex ligands; and combinations thereof. Preferred cation sources are metal ions and compounds of magnesium, sodium, potassium, cesium, calcium, barium, manganese, copper, zinc, tin, lithium, and rare earth metals. The acid copolymer may be at least partially neutralized prior to contacting the acid copolymer with the cation source to form the HNP. Methods of preparing ionomers are well known, and are disclosed, for example, in U.S. Pat. No. 3,264,272, the entire disclosure of which is hereby incorporated herein by reference. The acid copolymer can be a direct copolymer wherein the polymer is polymerized by adding all monomers simultaneously, as disclosed, for example, in U.S. Pat. No. 4,351,931, the entire disclosure of which is hereby incorporated herein by reference. Alternatively, the acid copolymer can be a graft copolymer wherein a monomer is grafted onto an existing polymer, as disclosed, for example, in U.S. Patent Application Publication No. 2002/0013413, the entire disclosure of which is hereby incorporated herein by reference.

**[0100]** Relatively soft/low modulus HNP compositions of the present invention optionally contain one or more melt flow modifiers. The amount of melt flow modifier in the composition is readily determined such that the melt flow index of the composition is at least 0.1 g/10 min, preferably from 0.5 g/10 min to 10.0 g/10 min, and more preferably from 1.0 g/10 min to 6.0 g/10 min, as measured using ASTM D-1238, condition E, at 190° C., using a 2160 gram weight.

**[0101]** Suitable melt flow modifiers include, but are not limited to, high molecular weight organic acids and salts thereof, polyamides, polyesters, polyacrylates, polyurethanes, polyethers, polyureas, polyhydric alcohols, and combinations thereof. Suitable organic acids are aliphatic organic acids, aromatic organic acids, saturated monofunctional organic acids, unsaturated monofunctional organic acids, multi-unsaturated monofunctional organic acids, and dimerized derivatives thereof. Particular examples of suitable organic acids include, but are not limited to, caproic acid, caprylic acid, capric acid, lauric acid, stearic acid, behenic acid, erucic acid, oleic acid, linoleic acid, myristic acid, benzoic acid, palmitic acid, phenylacetic acid, naphthalenoic acid, dimerized derivatives thereof. Suitable organic acids are more fully described, for example, in U.S. Pat. No. 6,756,436, the entire disclosure of which is hereby incorporated herein by reference. In a particular embodiment, the HNP composition comprises an organic acid salt in an amount of 20 phr or greater, or 25 phr or greater, or 30 phr or greater, or 35 phr or greater, or 40 phr or greater.

**[0102]** Additional melt flow modifiers suitable for use in compositions of the present invention, include the non-fatty acid melt flow modifiers described in U.S. Pat. Nos. 7,402,629 and 7,365,128, the entire disclosures of which are hereby incorporated herein by reference.

**[0103]** Relatively soft/low modulus HNP compositions of the present invention optionally include additive(s) and/or filler(s) in an amount of 50 wt % or less, or 30 wt % or less, or 15 wt % or less, based on the total weight of the relatively soft/low modulus HNP composition. Suitable additives and fillers include, but are not limited to, chemical blowing and foaming agents, optical brighteners, coloring agents, fluorescent agents, whitening agents, UV absorbers, light stabilizers, defoaming agents, processing aids, mica, talc, nanofillers, antioxidants, stabilizers, softening agents, fragrance components, plasticizers, impact modifiers, TiO<sub>2</sub>, acid copolymer wax, surfactants, and fillers, such as zinc oxide, tin oxide, barium sulfate, zinc sulfate, calcium oxide, calcium carbonate, zinc carbonate, barium carbonate, clay, tungsten, tungsten carbide, silica, lead silicate, regrind (recycled material), and mixtures thereof. Suitable additives are more fully described in, for example, U.S. Patent Application Publication No. 2003/0225197, the entire disclosure of which is hereby incorporated herein by reference.

**[0104]** Relatively soft/low modulus HNP compositions of the present invention optionally contain a high modulus HNP.

**[0105]** In a particular embodiment, the relatively soft/low modulus HNP composition has a moisture vapor transmission rate of 8 g-mil/100 in<sup>2</sup>/day or less (i.e., 3.2 g-mm/m<sup>2</sup>-day or less), or 5 g-mil/100 in<sup>2</sup>/day or less (i.e., 2.0 g-mm/m<sup>2</sup>-day or less), or 3 g-mil/100 in<sup>2</sup>/day or less (i.e., 1.2 g-mm/m<sup>2</sup>-day or less), or 2 g-mil/100 in<sup>2</sup>/day or less (i.e., 0.8 g-mm/m<sup>2</sup>-day or less), or 1 g-mil/100 in<sup>2</sup>/day or less (i.e., 0.4 g-mm/m<sup>2</sup>-day or less), or less than 1 g-mil/100 in<sup>2</sup>/day (i.e., less than 0.4 g-mm/m<sup>2</sup>-day). As used herein, moisture vapor transmission rate ("MVTR") is given in g-mil/100 in<sup>2</sup>/day, and is measured at 20° C. and according to ASTM F1249-99. In a preferred aspect of this embodiment, the relatively soft/low modulus HNP composition comprises a low modulus HNP prepared using a cation source which is less hydrophilic than conventional magnesium-based cation sources. Suitable moisture resistant HNP compositions are disclosed, for example, in U.S. Patent Application Publication Nos. 2005/0267240, 2006/0106175 and 2006/0293464, the entire disclosures of which are hereby incorporated herein by reference.

**[0106]** In another particular embodiment, a sphere formed from the relatively soft/low modulus HNP composition has a compression of 80 or less, or 70 or less, or 65 or less, or 60 or less, or 50 or less, or 40 or less, or 30 or less, or 20 or less.

**[0107]** Relatively soft/low modulus HNP compositions of the present invention are not limited by any particular method or any particular equipment for making the compositions. In a preferred embodiment, the composition is prepared by the following process. The acid polymer(s), preferably a VLMI-type ethylene-acid terpolymer, high molecular weight organic acid(s) or salt(s) thereof, and optionally additive(s)/filler(s) are simultaneously or individually fed into a melt extruder, such as a single or twin screw extruder. A suitable amount of cation source is simultaneously or subsequently added such that at least 80%, preferably at least 90%, more preferably at least 95%, and even more preferably at least 100%, of all acid groups present are neutralized. Optionally, the cation source is added in an amount sufficient to neutralize, theoretically, 105% or greater, or 110% or greater, or 115% or greater, or 120% or greater, or 125% or greater, or 200% or greater, or

250% or greater of all acid groups present in the composition. The acid polymer may be at least partially neutralized prior to the above process. The components are intensively mixed prior to being extruded as a strand from the die-head.

**[0108]** Relatively soft/low modulus HNP compositions of the present invention optionally comprise one or more additional polymers, such as partially neutralized ionomers (e.g., as disclosed in U.S. Patent Application Publication No. 2006/0128904, the entire disclosure of which is hereby incorporated herein by reference); bimodal ionomers (e.g., as disclosed in U.S. Patent Application Publication No. 2004/0220343 and U.S. Pat. Nos. 6,562,906, 6,762,246, 7,273,903, 8,193,283, 8,410,219, and 8,410,220, the entire disclosures of which are hereby incorporated herein by reference, and particularly Surlyn® AD 1043, 1092, and 1022 ionomer resins, commercially available from E. I. du Pont de Nemours and Company); ionomers modified with rosins (e.g., as disclosed in U.S. Patent Application Publication No. 2005/0020741, the entire disclosure of which is hereby incorporated by reference); soft and resilient ethylene copolymers (e.g., as disclosed U.S. Patent Application Publication No. 2003/0114565, the entire disclosure of which is hereby incorporated herein by reference); polyolefins; polyamides; polyesters; polyethers; polycarbonates; polysulfones; polyacetals; polylactones; acrylonitrile-butadiene-styrene resins; polyphenylene oxide; polyphenylene sulfide; styrene-acrylonitrile resins; styrene maleic anhydride; polyimides; aromatic polyketones; ionomers and ionomeric precursors, acid copolymers, and conventional HNPs; polyurethanes; grafted and non-grafted metallocene-catalyzed polymers; single-site catalyst polymerized polymers; high crystalline acid polymers; cationic ionomers; natural and synthetic rubbers, including, but not limited to, ethylene propylene rubber (“EPR”), ethylene propylene diene rubber (“EPDM”), styrenic block copolymer rubbers (such as SI, SIS, SB, SBS, SIBS, and the like, where “S” is styrene, “I” is isobutylene, and “B” is butadiene), butyl rubber, halobutyl rubber, copolymers of isobutylene and para-alkylstyrene, halogenated copolymers of isobutylene and para-alkylstyrene, natural rubber, polyisoprene, copolymers of butadiene with acrylonitrile, polychloroprene, alkyl acrylate rubber (such as ethylene-alkyl acrylates and ethylene-alkyl methacrylates, and, more specifically, ethylene-ethyl acrylate, ethylene-methyl acrylate, and ethylene-butyl acrylate), chlorinated isoprene rubber, acrylonitrile chlorinated isoprene rubber, and polybutadiene rubber (cis and trans); and combinations thereof. Particular polyolefins suitable for blending include one or more, linear, branched, or cyclic, C<sub>2</sub>-C<sub>40</sub> olefins, particularly polymers comprising ethylene or propylene copolymerized with one or more C<sub>2</sub>-C<sub>40</sub> olefins, C<sub>3</sub>-C<sub>20</sub> α-olefins, or C<sub>3</sub>-C<sub>10</sub> α-olefins. Particular conventional HNPs suitable for blending include, but are not limited to, one or more of the HNPs disclosed in U.S. Pat. Nos. 6,756,436, 6,894,098, and 6,953,820, the entire disclosures of which are hereby incorporated herein by reference. Additional suitable blend polymers include those described in U.S. Pat. No. 5,981,658, for example at column 14, lines 30 to 56, the entire disclosure of which is hereby incorporated herein by reference. The blends described herein may be produced by post-reactor blending, by connecting reactors in series to make reactor blends, or by using more than one catalyst in the same reactor to produce multiple species of polymer. The polymers may be mixed prior to being put into an extruder, or they may be mixed in

an extruder. In a particular embodiment, the HNP composition comprises an acid copolymer and an additional polymer component, wherein the additional polymer component is a non-acid polymer present in an amount of greater than 50 wt %, or an amount within a range having a lower limit of 50 or 55 or 60 or 65 or 70 and an upper limit of 80 or 85 or 90, based on the combined weight of the acid copolymer and the non-acid polymer. In another particular embodiment, the HNP composition comprises an acid copolymer and an additional polymer component, wherein the additional polymer component is a non-acid polymer present in an amount of less than 50 wt %, or an amount within a range having a lower limit of 10 or 15 or 20 or 25 or 30 and an upper limit of 40 or 45 or 50, based on the combined weight of the acid copolymer and the non-acid polymer.

**[0109]** Particularly suitable relatively soft/low modulus HNP compositions include, but are not limited to, the highly-resilient thermoplastic compositions disclosed in U.S. Patent Application Publication No. 2005/0148725; the highly-neutralized ethylene copolymers disclosed in U.S. Pat. Nos. 6,653,382 and 6,777,472, and U.S. Patent Application Publication No. 2003/0130434; and the highly-resilient thermoplastic elastomer compositions disclosed in U.S. Pat. No. 6,815,480; the entire disclosures of which are hereby incorporated herein by reference.

**[0110]** In a particular embodiment, the relatively soft/low modulus HNP composition is formed by blending an acid polymer, a non-acid polymer, a cation source, and a fatty acid or metal salt thereof. For purposes of the present invention, maleic anhydride modified polymers are defined herein as a non-acid polymer despite having anhydride groups that can ring-open to the acid form during processing of the polymer to form the HNP compositions herein. The maleic anhydride groups are grafted onto a polymer, are present at relatively very low levels, and are not part of the polymer backbone, as is the case with the acid polymers, which are exclusively E/X and E/X/Y copolymers of ethylene and an acid, particularly methacrylic acid and acrylic acid.

**[0111]** In a particular aspect of this embodiment, the acid polymer is selected from ethylene-acrylic acid and ethylene-methacrylic acid copolymers, optionally containing a softening monomer selected from n-butyl acrylate and iso-butyl acrylate. The acid polymer preferably has an acid content with a range having a lower limit of 2 or 10 or 15 or 16 mol % and an upper limit of 20 or 25 or 26 or 30 mol %. Examples of particularly suitable commercially available acid polymers include, but are not limited to, those given in Table 1 below.

TABLE 1

Acid Polymer	Acid (wt %)	Softening Monomer (wt %)	Melt Index (2.16 kg, 190° C., g/10 min)
Nucrel ® 9-1	methacrylic acid (9.0)	n-butyl acrylate (23.5)	25
Nucrel ® 599	methacrylic acid (10.0)	none	450
Nucrel ® 960	methacrylic acid (15.0)	none	60
Nucrel ® 0407	methacrylic acid (4.0)	none	7.5

TABLE 1-continued

Acid Polymer	Acid (wt %)	Softening Monomer (wt %)	Melt Index (2.16 kg, 190° C., g/10 min)
Nucrel ® 0609	methacrylic acid (6.0)	none	9
Nucrel ® 1214	methacrylic acid (12.0)	none	13.5
Nucrel ® 2906	methacrylic acid (19.0)	none	60
Nucrel ® 2940	methacrylic acid (19.0)	none	395
Nucrel ® 30707	acrylic acid (7.0)	none	7
Nucrel ® 31001	acrylic acid (9.5)	none	1.3
Nucrel ® AE	methacrylic acid (2.0)	isobutyl acrylate (6.0)	11
Nucrel ® 2806	acrylic acid (18.0)	none	60
Nucrel ® 0403	methacrylic acid (4.0)	none	3
Nucrel ® 925	methacrylic acid (15.0)	none	25
Escor ® AT-310	acrylic acid (6.5)	methyl acrylate (6.5)	6
Escor ® AT-325	acrylic acid (6.0)	methyl acrylate (20.0)	20
Escor ® AT-320	acrylic acid (6.0)	methyl acrylate (18.0)	5
Escor ® 5070	acrylic acid (9.0)	none	30
Escor ® 5100	acrylic acid (11.0)	none	8.5
Escor ® 5200	acrylic acid (15.0)	none	38
A-C ® 5120	acrylic acid (15)	none	not reported
A-C ® 540	acrylic acid (5)	none	not reported
A-C ® 580	acrylic acid (10)	none	not reported
Primacor ® 3150	acrylic acid (6.5)	none	5.8
Primacor ® 3330	acrylic acid (3.0)	none	11
Primacor ® 5985	acrylic acid (20.5)	none	240
Primacor ® 5986	acrylic acid (20.5)	none	300
Primacorv 5980I	acrylic acid (20.5)	none	300
Primacor ® 5990I	acrylic acid (20.0)	none	1300
XUS 60751.17	acrylic acid (19.8)	none	600
XUS 60753.02L	acrylic acid (17.0)	none	60

Nucrel ® acid polymers are commercially available from E. I. du Pont de Nemours and Company.

Escor ® acid polymers are commercially available from ExxonMobil Chemical Company.

A-C ® acid polymers are commercially available from Honeywell International Inc.

Primacor ® acid polymers and XUS acid polymers are commercially available from The Dow Chemical Company.

**[0112]** In another particular aspect of this embodiment, the non-acid polymer is an elastomeric polymer. Suitable elastomeric polymers include, but are not limited to:

**[0113]** (a) ethylene-alkyl acrylate polymers, particularly polyethylene-butyl acrylate, polyethylene-methyl acrylate, and polyethylene-ethyl acrylate;

**[0114]** (b) metallocene-catalyzed polymers;

**[0115]** (c) ethylene-butyl acrylate-carbon monoxide polymers and ethylene-vinyl acetate-carbon monoxide polymers;

**[0116]** (d) polyethylene-vinyl acetates;

**[0117]** (e) ethylene-alkyl acrylate polymers containing a cure site monomer;

**[0118]** (f) ethylene-propylene rubbers and ethylene-propylene-diene monomer rubbers;

**[0119]** (g) olefinic ethylene elastomers, particularly ethylene-octene polymers, ethylene-butene polymers, ethylene-propylene polymers, and ethylene-hexene polymers;

**[0120]** (h) styrenic block copolymers;

**[0121]** (i) polyester elastomers;

**[0122]** (j) polyamide elastomers;

**[0123]** (k) polyolefin rubbers, particularly polybutadiene, polyisoprene, and styrene-butadiene rubber; and

**[0124]** (l) thermoplastic polyurethanes.

**[0125]** Examples of particularly suitable commercially available non-acid polymers include, but are not limited to, Lotader® ethylene-alkyl acrylate polymers and Lotryl® ethylene-alkyl acrylate polymers, and particularly Lotader® 4210, 4603, 4700, 4720, 6200, 8200, and AX8900 commercially available from Arkema Corporation; Elvaloy® AC ethylene-alkyl acrylate polymers, and particularly AC 1224, AC 1335, AC 2116, AC3117, AC3427, and AC34035, commercially available from E. I. du Pont de Nemours and Company; Fusabond® elastomeric polymers, such as ethylene vinyl acetates, polyethylenes, metallocene-catalyzed polyethylenes, ethylene propylene rubbers, and polypropylenes, and particularly Fusabond® N525, C190, C250, A560, N416, N493, N614, P614, M603, E100, E158, E226, E265, E528, and E589, commercially available from E. I. du Pont de Nemours and Company; Honeywell A-C polyethylenes and ethylene maleic anhydride copolymers, and particularly A-C 5180, A-C 575, A-C 573, A-C 655, and A-C 395, commercially available from Honeywell; Nordel® IP rubber, Elite® polyethylenes, Engage® elastomers, and Amplify® functional polymers, and particularly Amplify® GR 207, GR 208, GR 209, GR 213, GR 216, GR 320, GR 380, and EA 100, commercially available from The Dow Chemical Company; Enable® metallocene polyethylenes, Exact® plastomers, Vistamaxx® propylene-based elastomers, and Vistalon® EPDM rubber, commercially available from ExxonMobil Chemical Company; Starflex® metallocene linear low density polyethylene, commercially available from LyondellBasell; Elvaloy® HP4051, HP441, HP661 and HP662 ethylene-butyl acrylate-carbon monoxide polymers and Elvaloy® 741, 742 and 4924 ethylene-vinyl acetate-carbon monoxide polymers, commercially available from E. I. du Pont de Nemours and Company; Evatane® ethylene-vinyl acetate polymers having a vinyl acetate content of from 18 to 42%, commercially available from Arkema Corporation; Elvax® ethylene-vinyl acetate polymers having a vinyl acetate content of from 7.5 to 40%, commercially available from E. I. du Pont de Nemours and Company; Vamac® G terpolymer of ethylene, methylacrylate and a cure site monomer, commercially available from E. I. du Pont de Nemours and Company; Vistalon® EPDM rubbers, commercially available from ExxonMobil Chemical Company; Kraton® styrenic block copolymers, and particularly Kraton® FG1901GT, FG1924GT, and RP6670GT, commercially available from Kraton Performance Polymers Inc.; Septon® styrenic block copolymers,

commercially available from Kuraray Co., Ltd.; Hytrel® polyester elastomers, and particularly Hytrel® 3078, 4069, and 556, commercially available from E. I. du Pont de Nemours and Company; Riteflex® polyester elastomers, commercially available from Celanese Corporation; Pebax® thermoplastic polyether block amides, and particularly Pebax® 2533, 3533, 4033, and 5533, commercially available from Arkema Inc.; Affinity® and Affinity® GA elastomers, Versify® ethylene-propylene copolymer elastomers, and Infuse® olefin block copolymers, commercially available from The Dow Chemical Company; Exxelor® polymer resins, and particularly Exxelor® PE 1040, PO 1015, PO 1020, VA 1202, VA 1801, VA 1803, and VA 1840, commercially available from ExxonMobil Chemical Company; and Royaltuf® EPDM, and particularly Royaltuf® 498 maleic anhydride modified polyolefin based on an amorphous EPDM and Royaltuf® 485 maleic anhydride modified polyolefin based on a semi-crystalline EPDM, commercially available from Chemtura Corporation.

**[0126]** Additional examples of particularly suitable commercially available elastomeric polymers include, but are not limited to, those given in Table 2 below.

TABLE 2

Polyethylene Butyl Acrylates	% Ester	% Maleic		Melt Index (2.16 kg, 190° C., g/10 min)
		Anhydride		
Lotader ® 3210	6	3.1		5
Lotader ® 4210	6.5	3.6		9
Lotader ® 3410	17	3.1		5
Lotryl ® 17BA04	16-19	0		3.5-4.5
Lotryl ® 35BA320	33-37	0		260-350
Elvaloy ® AC 3117	17	0		1.5
Elvaloy ® AC 3427	27	0		4
Elvaloy ® AC 34035	35	0		40

Polyethylene Methyl Acrylates	% Ester	% Maleic		Polyethylene Butyl Acrylates
		Anhydride		
Lotader ® 4503	19	0.3		8
Lotader ® 4603	26	0.3		8
Lotader ® AX 8900	26	8% GMA		6
Lotryl ® 24MA02	23-26	0		1-3
Elvaloy ® AC 12024S	24	0		20
Elvaloy ® AC 1330	30	0		3
Elvaloy ® AC 1335	35	0		3
Elvaloy ® AC 1224	24	0		2

Polyethylene Ethyl Acrylates	% Ester	% Maleic		Melt Index (2.16 kg, 190° C., g/10 min)
		Anhydride		
Lotader ® 6200	6.5	2.8		40
Lotader ® 8200	6.5	2.8		200
Lotader ® LX 4110	5	3.0		5
Lotader ® HX 8290	17	2.8		70
Lotader ® 5500	20	2.8		20
Lotader ® 4700	29	1.3		7
Lotader ® 4720	29	0.3		7
Elvaloy ® AC 2116	16	0		1

**[0127]** The acid polymer and non-acid polymer are combined and reacted with a cation source, such that at least 80% of all acid groups present are neutralized. The present invention is not meant to be limited by a particular order for combining and reacting the acid polymer, non-acid polymer and cation source. In a particular embodiment, the fatty acid or metal salt thereof is used in an amount such that the fatty acid or metal salt thereof is present in the HNP composition

in an amount of from 10 wt % to 60 wt %, or within a range having a lower limit of 10 or 20 or 30 or 40 wt % and an upper limit of 40 or 50 or 60 wt %, based on the total weight of the HNP composition. Suitable cation sources and fatty acids and metal salts thereof are further disclosed above.

**[0128]** In another particular aspect of this embodiment, the acid polymer is an ethylene-acrylic acid polymer having an acid content of 19 wt % or greater, the non-acid polymer is a metallocene-catalyzed ethylene-butene copolymer, optionally modified with maleic anhydride, the cation source is magnesium, and the fatty acid or metal salt thereof is magnesium oleate present in the composition in an amount of 20 to 50 wt %, based on the total weight of the composition.

#### Relatively Hard/High Modulus HNP Compositions

**[0129]** Relatively hard HNP compositions of the present invention have a Shore D hardness of 35 or greater, and preferably have a Shore D hardness of 45 or greater or a Shore D hardness with the range having a lower limit of 45 or 50 or 55 or 57 or 58 or 60 or 65 or 70 or 75 and an upper limit of 80 or 85 or 90 or 95. Alternatively, hard HNP compositions of the present invention have a material hardness within a range having a lower limit of 65 or 70 or 75 Shore C and an upper limit of 85 or 90 or 95 Shore C.

**[0130]** High modulus HNP compositions of the present invention comprise at least one high modulus HNP having a modulus within a range having a lower limit of 25,000 or 27,000 or 30,000 or 40,000 or 45,000 or 50,000 or 55,000 or 60,000 psi and an upper limit of 72,000 or 75,000 or 100,000 or 150,000 psi.

**[0131]** Relatively hard HNP compositions of the present invention comprise at least one highly neutralized acid polymer. In a preferred embodiment, the highly neutralized acid polymer of the relatively hard HNP composition is a high modulus HNP having a modulus within a range having a lower limit of 25,000 or 27,000 or 30,000 or 40,000 or 45,000 or 50,000 or 55,000 or 60,000 psi and an upper limit of 72,000 or 75,000 or 100,000 or 150,000 psi.

**[0132]** HNPs of the relatively hard/high modulus HNP compositions of the present invention are salts of acid copolymers. It is understood that the HNP may be a blend of two or more HNPs. Preferred acid copolymers are copolymers of an  $\alpha$ -olefin and a C<sub>3</sub>-C<sub>8</sub>  $\alpha,\beta$ -ethylenically unsaturated carboxylic acid. The acid is typically present in the acid copolymer in an amount within a range having a lower limit of 1 or 2 or 4 or 6 or 8 or 10 or 12 or 15 or 16 or 20 wt % and an upper limit of 20 or 25 or 26 or 30 or 35 or 40 wt %, based on the total weight of the acid copolymer. The  $\alpha$ -olefin is preferably selected from ethylene and propylene. The acid is preferably selected from (meth) acrylic acid, ethacrylic acid, maleic acid, crotonic acid, fumaric acid, and itaconic acid. (Meth) acrylic acid is particularly preferred. In a preferred embodiment, the HNP of the relatively hard HNP composition has a higher level of acid than the HNP of the relatively soft HNP composition.

**[0133]** Suitable acid copolymers include partially neutralized acid polymers. Examples of suitable partially neutralized acid polymers include, but are not limited to, Surlyn® ionomers, commercially available from E. I. du Pont de Nemours and Company; AClyn® ionomers, commercially available from Honeywell International Inc.; and Iotek® ionomers, commercially available from ExxonMobil Chemical Company. Also suitable are DuPont® HPF 1000,

HPF 2000, HPF AD 1035, HPF AD 1040, ionomeric materials commercially available from E. I. du Pont de Nemours and Company. Additional suitable acid polymers are more fully described, for example, in U.S. Pat. Nos. 6,562,906, 6,762,246, and 6,953,820 and U.S. Patent Application Publication Nos. 2005/0049367, 2005/0020741, and 2004/0220343, the entire disclosures of which are hereby incorporated herein by reference.

**[0134]** In a preferred embodiment, the HNP of the relatively hard/high modulus HNP composition is formed by reacting an acid copolymer, which may already be partially neutralized, with a sufficient amount of cation source, optionally in the presence of a high molecular weight organic acid or salt thereof, such that at least 80%, preferably at least 90%, more preferably at least 95%, and even more preferably 100%, of all acid groups present are neutralized. In a particular embodiment, the cation source is present in an amount sufficient to neutralize, theoretically, greater than 100%, or 105% or greater, or 110% or greater, or 115% or greater, or 120% or greater, or 125% or greater, or 200% or greater, or 250% or greater of all acid groups present in the composition. Suitable cation sources include metal ions and compounds of alkali metals, alkaline earth metals, and transition metals; metal ions and compounds of rare earth elements; silicone, silane, and silicate derivatives and complex ligands; and combinations thereof. Preferred cation sources are metal ions and compounds of magnesium, sodium, potassium, cesium, calcium, barium, manganese, copper, zinc, tin, lithium, and rare earth metals. Metal ions and compounds of calcium and magnesium are particularly preferred. The acid copolymer may be at least partially neutralized prior to contacting the acid copolymer with the cation source to form the HNP. As previously stated, methods of preparing ionomers, and the acid copolymers on which ionomers are based, are disclosed, for example, in U.S. Pat. Nos. 3,264,272, and 4,351,931, and U.S. Patent Application Publication No. 2002/0013413.

**[0135]** Relatively hard/high modulus HNP compositions of the present invention optionally contain one or more melt flow modifiers. The amount of melt flow modifier in the composition is readily determined such that the melt flow index of the composition is at least 0.1 g/10 min, preferably from 0.5 g/10 min to 10.0 g/10 min, and more preferably from 1.0 g/10 min to 6.0 g/10 min, as measured using ASTM D-1238, condition E, at 190° C., using a 2160 gram weight.

**[0136]** Suitable melt flow modifiers include, but are not limited to, high molecular weight organic acids and salts thereof, polyamides, polyesters, polyacrylates, polyurethanes, polyethers, polyureas, polyhydric alcohols, and combinations thereof. Suitable organic acids are aliphatic organic acids, aromatic organic acids, saturated mono-functional organic acids, unsaturated monofunctional organic acids, multi-unsaturated mono-functional organic acids, and dimerized derivatives thereof. Particular examples of suitable organic acids include, but are not limited to, caproic acid, caprylic acid, capric acid, lauric acid, stearic acid, behenic acid, erucic acid, oleic acid, linoleic acid, myristic acid, benzoic acid, palmitic acid, phenylacetic acid, naphthalenoic acid, dimerized derivatives thereof. Suitable organic acids are more fully described, for example, in U.S. Pat. No. 6,756,436, the entire disclosure of which is hereby incorporated herein by reference. In a particular embodiment, the HNP composition comprises an organic acid salt

in an amount of 20 phr or greater, or 25 phr or greater, or 30 phr or greater, or 35 phr or greater, or 40 phr or greater.

**[0137]** Additional melt flow modifiers suitable for use in compositions of the present invention, include the non-fatty acid melt flow modifiers described in U.S. Pat. Nos. 7,402,629 and 7,365,128, the entire disclosures of which are hereby incorporated herein by reference.

**[0138]** Relatively hard/high modulus HNP compositions of the present invention optionally include additive(s) and/or filler(s) in an amount within a range having a lower limit of 0 or 5 or 10 wt %, and an upper limit of 25 or 30 or 50 wt %, based on the total weight of the relatively hard/high modulus HNP composition. Suitable additives and fillers include those previously described as suitable for the relatively soft HNP compositions of the present invention.

**[0139]** Relatively hard/high modulus HNP compositions of the present invention optionally contain a low modulus HNP.

**[0140]** In a particular embodiment, the relatively hard/high modulus HNP composition has an MVTR of 8 g-mil/100 in<sup>2</sup>/day or less (i.e., 3.2 g-mm/m<sup>2</sup>-day or less), or 5 g-mil/100 in<sup>2</sup>/day or less (i.e., 2.0 g-mm/m<sup>2</sup>-day or less), or 3 g-mil/100 in<sup>2</sup>/day or less (i.e., 1.2 g-mm/m<sup>2</sup>-day or less), or 2 g-mil/100 in<sup>2</sup>/day or less (i.e., 0.8 g-mm/m<sup>2</sup>-day or less), or 1 g-mil/100 in<sup>2</sup>/day or less (i.e., 0.4 g-mm/m<sup>2</sup>-day or less), or less than 1 g-mil/100 in<sup>2</sup>/day (i.e., less than 0.4 g-mm/m<sup>2</sup>-day). In a preferred aspect of this embodiment, the relatively hard/high modulus HNP composition comprises a high modulus HNP prepared using a cation source which is less hydrophilic than conventional magnesium-based cation sources. Suitable moisture resistant HNP compositions are disclosed, for example, in U.S. patent application Ser. No. 11/270,066 and U.S. Patent Application Publication No. 2005/0267240, the entire disclosures of which are hereby incorporated herein by reference.

**[0141]** In another particular embodiment, a sphere formed from the relatively hard/high modulus HNP composition has a compression of 70 or greater, or 80 or greater, or a compression within a range having a lower limit of 70 or 80 or 90 or 100 and an upper limit of 110 or 130 or 140.

**[0142]** Relatively hard/high modulus HNP compositions of the present invention are not limited by any particular method or any particular equipment for making the compositions. In a preferred embodiment, the composition is prepared by the following process. The acid polymer(s), preferably an ethylene/(meth) acrylic acid copolymer, optional melt flow modifier(s), and optional additive(s)/filler(s) are simultaneously or individually fed into a melt extruder, such as a single or twin screw extruder. A suitable amount of cation source is then added such that at least 80%, preferably at least 90%, more preferably at least 95%, and even more preferably at least 100%, of all acid groups present are neutralized. Optionally, the cation source is added in an amount sufficient to neutralize, theoretically, 105% or greater, or 110% or greater, or 115% or greater, or 120% or greater, or 125% or greater, or 200% or greater, or 250% or greater of all acid groups present in the composition. The acid polymer may be at least partially neutralized prior to the above process. The components are intensively mixed prior to being extruded as a strand from the die-head.

**[0143]** In another preferred embodiment, the relatively hard/high modulus HNP composition is formed by combining a low modulus HNP with a sufficient amount of one or more additional material(s), including, but not limited to,



additives, fillers, and polymeric materials, to increase the modulus such that the resulting composition has a modulus as described above for the high modulus HNP.

**[0144]** Relatively hard/high modulus HNP compositions of the present invention may be blended with one or more additional polymers, such as thermoplastic polymers and elastomers. Examples of thermoplastic polymers and elastomers suitable for blending include those previously described as suitable for blending with the relatively soft/low modulus HNP compositions of the present invention. In a particular embodiment, the relatively hard/high modulus HNP composition comprises an acid copolymer and an additional polymer component, wherein the additional polymer component is a non-acid polymer present in an amount of greater than 50 wt %, or an amount within a range having a lower limit of 50 or 55 or 60 or 65 or 70 and an upper limit of 80 or 85 or 90, based on the combined weight of the acid copolymer and the non-acid polymer. In another particular embodiment, the relatively hard/high modulus HNP composition comprises an acid copolymer and an additional polymer component, wherein the additional polymer component is a non-acid polymer present in an amount of less than 50 wt %, or an amount within a range having a lower limit of 10 or 15 or 20 or 25 or 30 and an upper limit of 40 or 45 or 50, based on the combined weight of the acid copolymer and the non-acid polymer.

**[0145]** HNP compositions of the present invention, in the neat (i.e., unfilled) form, preferably have a specific gravity of from 0.95 g/cc to 0.99 g/cc. Any suitable filler, flake, fiber, particle, or the like, of an organic or inorganic material may be added to the HNP composition to increase or decrease the specific gravity, particularly to adjust the weight distribution within the golf ball, as further disclosed in U.S. Pat. Nos. 6,494,795, 6,547,677, 6,743,123, 7,074,137, and 6,688,991, the entire disclosures of which are hereby incorporated herein by reference.

**[0146]** In a particular embodiment, the relatively hard/high modulus HNP composition is formed by blending an acid polymer, a non-acid polymer, a cation source, and a fatty acid or metal salt thereof.

**[0147]** In a particular aspect of this embodiment, the acid polymer is selected from ethylene-acrylic acid and ethylene-methacrylic acid copolymers, optionally containing a softening monomer selected from n-butyl acrylate and iso-butyl acrylate. The acid polymer preferably has an acid content with a range having a lower limit of 2 or 10 or 15 or 16 mol % and an upper limit of 20 or 25 or 26 or 30 mol %. Examples of particularly suitable commercially available acid polymers include, but are not limited to, those given in Table 1 above.

**[0148]** In another particular aspect of this embodiment, the non-acid polymer is an elastomeric polymer. Suitable elastomeric polymers include, but are not limited to:

**[0149]** (a) ethylene-alkyl acrylate polymers, particularly polyethylene-butyl acrylate, polyethylene-methyl acrylate, and polyethylene-ethyl acrylate;

**[0150]** (b) metallocene-catalyzed polymers;

**[0151]** (c) ethylene-butyl acrylate-carbon monoxide polymers and ethylene-vinyl acetate-carbon monoxide polymers;

**[0152]** (d) polyethylene-vinyl acetates;

**[0153]** (e) ethylene-alkyl acrylate polymers containing a cure site monomer;

**[0154]** (f) ethylene-propylene rubbers and ethylene-propylene-diene monomer rubbers;

**[0155]** (g) olefinic ethylene elastomers, particularly ethylene-octene polymers, ethylene-butene polymers, ethylene-propylene polymers, and ethylene-hexene polymers;

**[0156]** (h) styrenic block copolymers;

**[0157]** (i) polyester elastomers;

**[0158]** (j) polyamide elastomers;

**[0159]** (k) polyolefin rubbers, particularly polybutadiene, polyisoprene, and styrene-butadiene rubber; and

**[0160]** (l) thermoplastic polyurethanes.

**[0161]** Examples of particularly suitable commercially available non-acid polymers include, but are not limited to, Lotader® ethylene-alkyl acrylate polymers and Lotryl® ethylene-alkyl acrylate polymers, and particularly Lotader® 4210, 4603, 4700, 4720, 6200, 8200, and AX8900 commercially available from Arkema Corporation; Elvaloy® AC ethylene-alkyl acrylate polymers, and particularly AC 1224, AC 1335, AC 2116, AC3117, AC3427, and AC34035, commercially available from E. I. du Pont de Nemours and Company; Fusabond® elastomeric polymers, such as ethylene vinyl acetates, polyethylenes, metallocene-catalyzed polyethylenes, ethylene propylene rubbers, and polypropylenes, and particularly Fusabond® N525, C190, C250, A560, N416, N493, N614, P614, M603, E100, E158, E226, E265, E528, and E589, commercially available from E. I. du Pont de Nemours and Company; Honeywell A-C polyethylenes and ethylene maleic anhydride copolymers, and particularly A-C 5180, A-C 575, A-C 573, A-C 655, and A-C 395, commercially available from Honeywell; Nordel® IP rubber, Elite® polyethylenes, Engage® elastomers, and Amplify® functional polymers, and particularly Amplify® GR 207, GR 208, GR 209, GR 213, GR 216, GR 320, GR 380, and EA 100, commercially available from The Dow Chemical Company; Enable® metallocene polyethylenes, Exact® plastomers, Vistamaxx® propylene-based elastomers, and Vistalon® EPDM rubber, commercially available from ExxonMobil Chemical Company; Starflex® metallocene linear low density polyethylene, commercially available from LyondellBasell; Elvaloy® HP4051, HP441, HP661 and HP662 ethylene-butyl acrylate-carbon monoxide polymers and Elvaloy® 741, 742 and 4924 ethylene-vinyl acetate-carbon monoxide polymers, commercially available from E. I. du Pont de Nemours and Company; Evatane® ethylene-vinyl acetate polymers having a vinyl acetate content of from 18 to 42%, commercially available from Arkema Corporation; Elvax® ethylene-vinyl acetate polymers having a vinyl acetate content of from 7.5 to 40%, commercially available from E. I. du Pont de Nemours and Company; Vamac® G terpolymer of ethylene, methylacrylate and a cure site monomer, commercially available from E. I. du Pont de Nemours and Company; Vistalon® EPDM rubbers, commercially available from ExxonMobil Chemical Company; Kraton® styrenic block copolymers, and particularly Kraton® FG1901GT, FG1924GT, and RP6670GT, commercially available from Kraton Performance Polymers Inc.; Septon® styrenic block copolymers, commercially available from Kuraray Co., Ltd.; Hytrel® polyester elastomers, and particularly Hytrel® 3078, 4069, and 556, commercially available from E. I. du Pont de Nemours and Company; Riteflex® polyester elastomers, commercially available from Celanese Corporation; Pebax® thermoplastic polyether block amides, and particularly

Pebax® 2533, 3533, 4033, and 5533, commercially available from Arkema Inc.; Affinity® and Affinity® GA elastomers, Versify® ethylene-propylene copolymer elastomers, and Infuse® olefin block copolymers, commercially available from The Dow Chemical Company; Exxelcor® polymer resins, and particularly Exxelcor® PE 1040, PO 1015, PO 1020, VA 1202, VA 1801, VA 1803, and VA 1840, commercially available from ExxonMobil Chemical Company; and Royaltuf® EPDM, and particularly Royaltuf® 498 maleic anhydride modified polyolefin based on an amorphous EPDM and Royaltuf® 485 maleic anhydride modified polyolefin based on a semi-crystalline EPDM, commercially available from Chemtura Corporation.

**[0162]** Additional examples of particularly suitable commercially available elastomeric polymers include, but are not limited to, those given in Table 2 above.

**[0163]** The acid polymer and non-acid polymer are combined and reacted with a cation source, such that at least 80% of all acid groups present are neutralized. The present invention is not meant to be limited by a particular order for combining and reacting the acid polymer, non-acid polymer and cation source. In a particular embodiment, the fatty acid or metal salt thereof is used in an amount such that the fatty acid or metal salt thereof is present in the HNP composition in an amount of from 10 wt % to 60 wt %, or within a range having a lower limit of 10 or 20 or 30 or 40 wt % and an upper limit of 40 or 50 or 60 wt %, based on the total weight of the HNP composition. Suitable cation sources and fatty acids and metal salts thereof are further disclosed above.

**[0164]** In another particular aspect of this embodiment, the acid polymer is an ethylene-acrylic acid polymer having an acid content of 19 wt % or greater, the non-acid polymer is a metallocene-catalyzed ethylene-butene copolymer, optionally modified with maleic anhydride, the cation source is magnesium, and the fatty acid or metal salt thereof is magnesium oleate present in the composition in an amount of 20 to 50 wt %, based on the total weight of the composition.

#### Golf Ball Applications

**[0165]** Golf balls of the present invention comprise a first layer  $L_1$ , a second layer  $L_2$  surrounding  $L_1$ , and a third layer  $L_3$  surrounding  $L_2$ .  $L_1$  is formed from at least one highly neutralized polymer and has a first specific gravity  $SG_1$ ;  $L_2$  is formed of at least one partially neutralized polymer and has a second specific gravity  $SG_2$ ; and  $L_3$  is formed from at least one polyurethane and has a third specific gravity  $SG_3$ . At least two of  $SG_1$ ,  $SG_2$ , and  $SG_3$  is less than 1.13 g/cc. The golf ball has a specific gravity  $SG_B$  of less than 1.00 g/cc, and an initial velocity of at least 250 ft/s. The difference in Shore C hardness between a center of  $L_1$  and an outer surface of  $L_1$  will generally be from 0 to 8 hardness points, but embodiments are indeed envisioned wherein the Shore C hardness differential is greater.

**[0166]** Alternatively,  $L_1$  may be formed of at least one rubber and have a first specific gravity  $SG_1$ ;  $L_2$  is formed of at least one highly neutralized polymer and has a second specific gravity  $SG_2$ ; and  $L_3$  is formed from at least one partially neutralized polymer and has a third specific gravity  $SG_3$ . The golf ball has a specific gravity  $SG_B$  of less than 1.00 g/cc, and an initial velocity of at least 250 ft/s. The difference in Shore C hardness between a center of  $L_1$  and

an outer surface of  $L_1$  may be from 0 to 8 hardness points; or greater than 8 and up to 22 hardness points; or greater than 22 hardness points.

**[0167]** The HNP composition can be a relatively soft HNP composition and/or a relatively hard HNP composition, a low modulus HNP composition and/or a high modulus HNP composition, or combinations/blends thereof.

**[0168]** Embodiments are also envisioned wherein a golf ball of the invention includes multiple layers that are formed from HNP compositions, as long as the golf ball has a specific gravity  $SG_B$  of less than 1.00 g/cc, and an initial velocity of at least 250 ft/s. For example, one such layer may be formed from a relatively soft HNP composition, while a second layer and a layer formed from a relatively hard HNP composition. In another embodiment, the present invention provides a golf ball having a dual-layer core and a dual-layer cover, wherein the dual-layer core includes a layer formed from a low modulus HNP composition and a layer formed from a high modulus HNP composition.

**[0169]** In some the embodiments, the relatively soft/low modulus HNP composition and/or the relatively hard/high modulus HNP composition can be either foamed or filled with density adjusting materials to provide desirable golf ball performance characteristics.

**[0170]** Golf balls having a layer formed from a relatively soft HNP composition and a layer formed from a relatively hard HNP composition are further disclosed, for example, in U.S. Patent Application Publication No. 2007/0207880, the entire disclosure of which is hereby incorporated herein by reference.

**[0171]** Golf balls having a layer formed from a low modulus HNP composition and a layer formed from a high modulus HNP composition are further disclosed, for example, in U.S. Pat. No. 7,211,008, the entire disclosure of which is hereby incorporated herein by reference.

**[0172]** In embodiments of the present invention wherein the core includes a layer formed from a composition other than a relatively soft HNP composition or a relatively hard HNP composition, such layer may be formed from any suitable golf ball composition. Preferably, the layer that is not formed from a relatively soft HNP composition or a relatively hard HNP composition is formed from a rubber composition or from a highly resilient thermoplastic polymer such as a conventional HNP composition. Particularly suitable thermoplastic polymers include Surlyn® ionomers, Hytrel® thermoplastic polyester elastomers, and ionomeric materials sold under the trade names DuPont® HPF 1000, HPF 2000, HPF AD 1035, HPF AD 1040, all of which are commercially available from E. I. du Pont de Nemours and Company; Iotek® ionomers, commercially available from ExxonMobil Chemical Company; and Pebax® thermoplastic polyether block amides, commercially available from Arkema Inc. Suitable rubber and thermoplastic polymer compositions are further disclosed below.

**[0173]** In one embodiment, the present invention is directed to a golf ball comprising a center, an outer core layer, an intermediate core layer disposed between the center and the outer core layer, and one or more cover layers. In a particular aspect of this embodiment, the golf ball has one or more of the following properties:

**[0174]** (a) a center having a diameter within a range having a lower limit of 0.250 or 0.500 or 0.600 or 0.750 or 0.800 or 1.000 or 1.100 or 1.200 inches and an upper

- limit of 1.300 or 1.350 or 1.400 or 1.500 or 1.510 or 1.530 or 1.550 or 1.570 or 1.580 or 1.600 inches;
- [0175]** (b) an intermediate core layer having a thickness within a range having a lower limit of 0.020 or 0.025 or 0.032 or 0.050 or 0.075 or 0.100 or 0.125 inches and an upper limit of 0.150 or 0.175 or 0.200 or 0.220 or 0.250 or 0.280 or 0.300 inches;
- [0176]** (c) an outer core layer having a thickness within a range having a lower limit of 0.010 or 0.020 or 0.025 or 0.030 or 0.032 inches and an upper limit of 0.070 or 0.080 or 0.100 or 0.150 or 0.310 or 0.440 or 0.560 inches;
- [0177]** (d) an intermediate core layer and an outer core layer having a combined thickness within a range having a lower limit of 0.040 inches and an upper limit of 0.560 or 0.800 inches;
- [0178]** (e) an outer core layer having a thickness such that a golf ball subassembly including the center, intermediate core layer, and core layer has an outer diameter within a range having a lower limit of 1.000 or 1.300 or 1.400 or 1.450 or 1.500 or 1.510 or 1.530 or 1.550 inches and an upper limit of 1.560 or 1.570 or 1.580 or 1.590 or 1.600 or 1.620 or 1.640 inches;
- [0179]** (f) a center having a surface hardness of 65 Shore C or greater, or 70 Shore C or greater, or a surface hardness within a range having a lower limit of 55 or 60 or 65 or 70 or 75 Shore C and an upper limit of 80 or 85 Shore C;
- [0180]** (g) a center having a center hardness (H) within a range having a lower limit of 20 or 25 or 30 or 35 or 45 or 50 or 55 Shore C and an upper limit of 60 or 65 or 70 or 75 or 90 Shore C; an outer core layer having a surface hardness (S) within a range having a lower limit of 20 or 25 or 30 or 35 or 45 or 55 Shore C and an upper limit of 60 or 70 or 75 or 90 Shore C; and
- [0181]** (i)  $H=S$ ;
- [0182]** (ii)  $H<S$ , and the difference between H and S is from -15 to 40, preferably from -15 to 22, more preferably from -10 to 15, and even more preferably from -5 to 10; or
- [0183]** (iii)  $SCH$ , and the difference between H and S is from -15 to 40, preferably from -15 to 22, more preferably from -10 to 15, and even more preferably from -5 to 10;
- [0184]** (h) an intermediate layer having a surface hardness (I) that is greater than both the center hardness of the center (H) and the surface hardness of the outer core layer (S); I is preferably 40 Shore C or greater or within a range having a lower limit of 40 or 45 or 50 or 85 Shore C and an upper limit of 90 or 93 or 95 Shore C; the Shore D range for I is preferably from 40 to 80, more preferably from 50 to 70; (i) each core layer having a specific gravity of from 0.50 g/cc to 5.00 g/cc; preferably from 1.05 g/cc to 1.25 g/cc; more preferably from 1.10 g/cc to 1.18 g/cc;
- [0185]** (j) a center having a surface hardness greater than or equal to the center hardness of the center;
- [0186]** (k) a center having a positive hardness gradient wherein the surface hardness of the center is at least 10 Shore C units greater than the center hardness of the center;
- [0187]** (l) an outer core layer having a surface hardness greater than or equal to the surface hardness and center hardness of the center;
- [0188]** (m) a center having a compression of 40 or less;
- [0189]** (n) a center having a compression of from 20 to 40; and
- [0190]** (o) a golf ball subassembly including the center and the intermediate core layer has a compression of 30 or greater, or 40 or greater, or 50 or greater, or 60 or greater, or a compression within a range having a lower limit of 30 or 40 or 50 or 60 and an upper limit of 65 or 75 or 85 or 95 or 105.
- [0191]** In another embodiment, the present invention is directed to a golf ball comprising a center, an outer core layer, an intermediate core layer disposed between the center and the outer core layer, and one or more cover layers, wherein the golf ball has one or more of the following properties:
- [0192]** (a) a center having a diameter within a range having a lower limit of 0.100 or 0.125 or 0.250 inches and an upper limit of 0.375 or 0.500 or 0.750 or 1.000 inches;
- [0193]** (b) an intermediate core layer having a thickness within a range having a lower limit of 0.050 or 0.075 or 0.100 or 0.125 or 0.150 or 0.200 inches and an upper limit of 0.300 or 0.350 or 0.400 or 0.500 inches;
- [0194]** (c) an outer core layer having a thickness within a range having a lower limit of 0.010 or 0.020 or 0.025 or 0.030 or 0.032 inches and an upper limit of 0.070 or 0.080 or 0.100 or 0.150 or 0.310 or 0.440 or 0.560 inches;
- [0195]** (d) an outer core layer having a thickness such that a golf ball subassembly including the center, intermediate core layer, and core layer has an outer diameter within a range having a lower limit of 1.000 or 1.300 or 1.400 or 1.450 or 1.500 or 1.510 or 1.530 or 1.550 inches and an upper limit of 1.560 or 1.570 or 1.580 or 1.590 or 1.600 or 1.620 or 1.640 or 1.660 inches;
- [0196]** (e) a center having a surface hardness of 65 Shore C or greater, or 70 Shore C or greater, or greater than 70 Shore C, or 80 Shore C or greater, or a surface hardness within a range having a lower limit of 70 or 75 or 80 Shore C and an upper limit of 90 or 95 Shore C;
- [0197]** (f) an outer core layer having a surface hardness less than or equal to the surface hardness of the center;
- [0198]** (g) an outer core having a surface hardness of 65 Shore C or greater, or 70 Shore C or greater, or greater than 70 Shore C, or 80 Shore C or greater, or 85 Shore C or greater;
- [0199]** (h) an intermediate core layer having a surface hardness that is less than both the surface hardness of the center and the surface hardness of the outer core layer;
- [0200]** (i) an intermediate core layer having a surface hardness of less than 80 Shore C, or less than 70 Shore C, or less than 60 Shore C;
- [0201]** (j) a center specific gravity less than or equal to or substantially the same as (i.e., within 0.1 g/cc) the outer core layer specific gravity;
- [0202]** (j) a center specific gravity within a range having a lower limit of 0.50 or 0.90 or 1.05 or 1.13 g/cc and an upper limit of 1.15 or 1.18 or 1.20 g/cc;
- [0203]** (k) an outer core layer specific gravity of 1.00 g/cc or greater, or 1.05 g/cc or greater, or 1.10 g/cc or greater;

- [0204]** (l) an intermediate core layer specific gravity of 1.00 g/cc or greater, or 1.05 g/cc or greater, or 1.10 g/cc or greater;
- [0205]** (m) an intermediate core layer specific gravity substantially the same as (i.e., within 0.1 g/cc) the outer core layer specific gravity;
- [0206]** (n) a center having a surface hardness greater than or equal to the center hardness of the center;
- [0207]** (o) a center having a positive hardness gradient wherein the surface hardness of the center is at least 10 Shore C units greater than the center hardness of the center; (p) a center having a compression of 40 or less;
- [0208]** (q) a center having a compression of from 20 to 40; and
- [0209]** (r) a golf ball subassembly including the center and the intermediate core layer has a compression of 30 or greater, or 40 or greater, or 50 or greater, or 60 or greater, or a compression within a range having a lower limit of 30 or 40 or 50 or 60 or 65 and an upper limit of 70 or 75 or 85 or 90 or 95 or 105.
- [0210]** In another embodiment, the present invention is directed to a golf ball comprising a center, an outer core layer, and one or more cover layers. In a particular aspect of this embodiment, the golf ball has one or more of the following properties:
- [0211]** (a) a center having a diameter within a range having a lower limit of 0.500 or 0.750 or 1.000 or 1.100 or 1.200 inches and an upper limit of 1.300 or 1.350 or 1.400 or 1.550 or 1.570 or 1.580 inches;
- [0212]** (b) a center having a diameter within a range having a lower limit of 0.750 or 0.850 or 0.875 inches and an upper limit of 1.125 or 1.150 or 1.190 inches;
- [0213]** (c) an outer core layer enclosing the center such that the dual-layer core has an overall diameter within a range having a lower limit of 1.400 or 1.500 or 1.510 or 1.520 or 1.525 inches and an upper limit of 1.540 or 1.550 or 1.555 or 1.560 or 1.590 or 1.60 or 1.65 or 1.70 or 1.75 inches, or an outer core layer having a thickness within a range having a lower limit of 0.020 or 0.025 or 0.032 or 0.100 or 0.110 or 0.115 or 0.120 or 0.125 or 0.150 or 0.200 inches and an upper limit of 0.210 or 0.220 or 0.240 or 0.260 or 0.270 or 0.280 or 0.310 or 0.440 or 0.560 inches;
- [0214]** (d) a center having a center hardness of 50 Shore C or greater, or 55 Shore C or greater, or 60 Shore C or greater, or a center hardness within a range having a lower limit of 50 or 55 or 60 Shore C and an upper limit of 65 or 70 or 80 Shore C;
- [0215]** (e) a center having a surface hardness of 65 Shore C or greater, or 70 Shore C or greater, or a surface hardness within a range having a lower limit of 55 or 60 or 65 or 70 or 75 Shore C and an upper limit of 80 or 85 Shore C;
- [0216]** (f) a center having a center hardness within a range having a lower limit of 10 or 15 Shore C and an upper limit of 25 or 30 or 35 Shore C, and a surface hardness within a range having a lower limit of 15 or 20 Shore C and an upper limit of 35 or 40 or 45 Shore C, and optionally a positive hardness gradient wherein the center hardness is at least 3 Shore C units less than the surface hardness;
- [0217]** (g) an outer core layer having a surface hardness of 75 Shore C or greater, or 80 Shore C or greater, or greater than 80 Shore C, or 85 Shore C or greater, or greater than 85 Shore C, or 87 Shore C or greater, or greater than 87 Shore C, or 89 Shore C or greater, or greater than 89 Shore C, or 90 Shore C or greater, or greater than 90 Shore C, or a surface hardness within a range having a lower limit of 75 or 80 or 85 Shore C and an upper limit of 95 Shore C;
- [0218]** (h) a center having a surface hardness greater than or equal to the center hardness of the center;
- [0219]** (i) a center having a positive hardness gradient wherein the surface hardness of the center is at least 10 Shore C units greater than the center hardness of the center; (j) an outer core layer having a surface hardness greater than or equal to the surface hardness and center hardness of the center;
- [0220]** (k) a core having a positive hardness gradient wherein the surface hardness of the outer core layer is at least 20 Shore C units greater, or at least 25 Shore C units greater, or at least 30 Shore C units greater, than the center hardness of the center;
- [0221]** (l) a center having a compression of 40 or less, or 30 or less, or 20 or less; and
- [0222]** (m) a center having a compression of from -20 or -10 or 0 or 20 to 25 or 30 or 40.
- [0223]** The weight distribution of cores disclosed herein can be varied to achieve certain desired parameters, such as spin rate, compression, and initial velocity.
- [0224]** Golf ball cores of the present invention typically have an overall core compression of less than 100, or a compression of 87 or less, or an overall core compression within a range having a lower limit of 20 or 30 or 35 or 40 or 50 or 60 or 65 or 70 or 75 and an upper limit of 60 or 65 or 70 or 75 or 80 or 85 or 90 or 100 or 110 or 120, or an overall core compression of about 80. Compression is an important factor in golf ball design. For example, the compression of the core can affect the ball's spin rate off the driver and the feel.
- [0225]** For purposes of golf balls of the present invention, "compression" refers to DCM compression. In the present invention, a solid 1.55" sphere of inventive material may have a DCM compression anywhere at or below the Atti range of from -75 to about 200, depending on the desired properties of the resulting golf ball. The Dynamic Compression Machine ("DCM") is an apparatus that applies a load to a core or ball and measures the number of inches the core or ball is deflected at measured loads. A crude load/deflection curve is generated that is fit to the Atti compression scale that results in a number being generated representing an Atti compression. The DCM does this via a load cell attached to the bottom of a hydraulic cylinder that is triggered pneumatically at a fixed rate (typically about 30 inches per minute) towards a stationary core. Attached to the cylinder is an LVDT that measures the distance the cylinder travels during the testing timeframe. A software-based logarithmic algorithm ensures that measurements are not taken until at least five successive increases in load are detected during the initial phase of the test. DCM is often used to capture compressions that fall outside the Atti compression scale range of -75 to 200, since the DCM scale compression range is -246 to 200.
- [0226]** This being said, in many embodiments of golf balls of the invention, compression can also be defined in terms of Atti compression. As disclosed in Jeff Dalton's *Compression by Any Other Name, Science and Golf IV, Proceedings of the World Scientific Congress of Golf* (Eric Thain ed.,

Routledge, 2002) (“J. Dalton”), several different methods can be used to measure compression, including Atti compression, Riehle compression, load/deflection measurements at a variety of fixed loads and offsets, and effective modulus. Atti compression may also be measured according to a known procedure, using an Atti compression test device, wherein a piston is used to compress a ball against a spring. The travel of the piston is fixed and the deflection of the spring is measured. The measurement of the deflection of the spring does not begin with its contact with the ball; rather, there is an offset of approximately the first 1.25 mm (0.05 inches) of the spring’s deflection. Very low stiffness cores will not cause the spring to deflect by more than 1.25 mm and therefore have a zero compression measurement. The Atti compression tester is designed to measure objects having a diameter of 42.7 mm (1.68 inches); thus, smaller objects, such as golf ball cores, must be shimmed to a total height of 42.7 mm to obtain an accurate reading. Conversion from Atti compression to Riehle (cores), Riehle (balls), 100 kg deflection, 130-10 kg deflection or effective modulus can be carried out according to the formulas given in J. Dalton.

**[0227]** Coefficient of restitution (“CoR”), as used herein, is determined according to a known procedure wherein a golf ball or golf ball subassembly (e.g., a golf ball core) is fired from an air cannon at a given velocity (125 ft/s for purposes of the present invention). Ballistic light screens are located between the air cannon and the steel plate to measure ball velocity. As the ball travels toward the steel plate, it activates each light screen, and the time at each light screen is measured. This provides an incoming transit time period proportional to the ball’s incoming velocity. The ball impacts the steel plate and rebounds through the light screens, which again measure the time period required to transit between the light screens. This provides an outgoing transit time period proportional to the ball’s outgoing velocity. CoR is then calculated as the ratio of the outgoing transit time period to the incoming transit time period,  $CoR = T_{out} / T_{in}$ .

**[0228]** The Rules of Golf, as set forth by the United States Golf Association (“USGA”) and the Royal and Ancient Golf Club of Saint Andrews, have placed controls on the construction and performance of golf balls. The golf ball rules require that the golf ball have a diameter no less than 1.68 inches (42.67 mm), a weight no more than 1.620 ounces avoirdupois (45.93 g), spherical symmetry, an overall distance no greater than 296.8 yards (the limit is 280 yards, or 256 m, plus a six percent tolerance for the total distance of 296.8 yards), and an initial velocity no greater than 255.0 feet per second (the limit is 250 feet or 76.2 m, per second with a two percent maximum tolerance that allows for an initial velocity of 255 feet per second) measured on a USGA approved apparatus.

**[0229]** The initial velocity test is comprised of a large 200 pound wheel that rotates around a central axis at a rate of 143.8 feet per second (striker tangential velocity) and strikes a stationary golf ball resting on a tee. The wheel has a flat plate that protrudes during its final revolution prior to impact with the golf ball. The ball’s velocity is then measured via light gates as it travels approximately six feet through an enclosed tunnel. Balls are kept in an incubator at a constant temperature of 23 degrees Celsius for at least three hours before they are tested for initial velocity performance. To test for initial velocity, balls are placed on a tee and hit with the metal striker described above. Twenty-four balls of a

particular type make up one test. Each ball is hit with the spinning wheel a total of four times. The highest and lowest recorded velocities are eliminated and the remaining two velocities are averaged to determine the ball speed for that specific ball. The individual speeds of the 24 balls in the group are then averaged, and that is considered the mean initial velocity (IV) of the group for the test.

**[0230]** Generally speaking, the USGA IV test is designed to be a consistent measurement tool capable of regulating the speed of golf balls. It is commonly known in the industry that golf ball manufacturers perform a simpler test on prototype golf balls and then attempt to correlate the results to the USGA Wheel Test. The Coefficient of Restitution “CoR” test discussed above is one type of correlation test.

**[0231]** Cores of the present invention are enclosed with a cover, which may be a single-, dual-, or multi-layer cover.

**[0232]** Suitable cover layer materials for the golf balls disclosed herein include, but are not limited to, ionomer resin and blends thereof (particularly Surlyn® ionomer resin), polyurethanes, polyureas, (meth)acrylic acid, thermoplastic rubber polymers, polyethylene, and synthetic or natural vulcanized rubber, such as balata. Suitable commercially available ionomeric cover materials include, but are not limited to, Surlyn® ionomer resins and DuPont® HPF 1000, HPF 2000, HPF AD 1035, HPF AD 1040, commercially available from E. I. du Pont de Nemours and Company; and Iotek® ionomers, commercially available from ExxonMobil Chemical Company.

**[0233]** Particularly suitable outer cover layer materials include relatively soft polyurethanes and polyureas. When used as cover layer materials, polyurethanes and polyureas can be thermoset or thermoplastic. Thermoset materials can be formed into golf ball layers by conventional casting or reaction injection molding techniques. Thermoplastic materials can be formed into golf ball layers by conventional compression or injection molding techniques. Light stable polyureas and polyurethanes are preferred for the outer cover layer material. Additional suitable cover and rubber core materials are disclosed, for example, in U.S. Patent Application Publication No. 2005/0164810, U.S. Pat. No. 5,919,100, and PCT Publications WO00/23519 and WO00/29129, the entire disclosures of which are hereby incorporated herein by reference. In embodiments of the present invention wherein a golf ball having a single layer cover is provided, the cover layer material is preferably selected from polyurethane and polyurea. In embodiments of the present invention wherein a golf ball having a dual cover is provided, the inner cover layer is preferably a high modulus thermoplastic, and the outer cover layer is preferably selected from polyurethane and polyurea.

**[0234]** Suitable cover layer materials also include blends of ionomers with thermoplastic elastomers. Suitable ionomeric cover materials are further disclosed, for example, in U.S. Pat. Nos. 6,653,382, 6,756,436, 6,894,098, 6,919,393, and 6,953,820, the entire disclosures of which are hereby incorporated by reference. Suitable polyurethane cover materials are further disclosed in U.S. Pat. Nos. 5,334,673, 6,506,851, 6,756,436, and 7,105,623, the entire disclosures of which are hereby incorporated herein by reference. Suitable polyurea cover materials are further disclosed in U.S. Pat. Nos. 5,484,870 and 6,835,794, the entire disclosures of which are hereby incorporated herein by reference. Suitable polyurethane-urea hybrids are blends or copolymers comprising urethane or urea segments as disclosed in U.S. Patent

Application Publication No. 2007/0117923, the entire disclosure of which is hereby incorporated herein by reference. Additional suitable cover materials are disclosed, for example, in U.S. Patent Application Publication No. 2005/0164810, U.S. Pat. No. 5,919,100, and PCT Publications WO00/23519 and WO00/29129, the entire disclosures of which are hereby incorporated herein by reference.

**[0235]** The ionomeric composition of the inner cover layer is preferably selected from:

**[0236]** (a) a composition comprising a “high acid ionomer” (i.e., having an acid content of greater than 16 wt %), such as Surlyn 8150®, a copolymer of ethylene and methacrylic acid, having an acid content of 19 wt %, which is 45% neutralized with sodium, commercially available from E. I. du Pont de Nemours and Company;

**[0237]** (b) a composition comprising a high acid ionomer and a maleic anhydride-grafted non-ionomeric polymer (e.g., Fusabond 572D®, a maleic anhydride-grafted, metallocene-catalyzed ethylene-butene copolymer having about 0.9 wt % maleic anhydride grafted onto the copolymer, commercially available from E. I. du Pont de Nemours and Company). A particularly preferred blend of high acid ionomer and maleic anhydride-grafted polymer is a 84 wt %/16 wt % blend of Surlyn 8150® and Fusabond 572D®. Blends of high acid ionomers with maleic anhydride-grafted polymers are further disclosed, for example, in U.S. Pat. Nos. 6,992,135 and 6,677,401, the entire disclosures of which are hereby incorporated herein by reference;

**[0238]** (c) a composition comprising a 50/45/5 blend of Surlyn® 8940/Surlyn® 9650/Nucrel® 960, preferably having a material hardness of from 80 to 85 Shore C;

**[0239]** (d) a composition comprising a 50/25/25 blend of Surlyn® 8940/Surlyn® 9650/Surlyn® 9910, preferably having a material hardness of about 90 Shore C; and

**[0240]** (e) a composition comprising a 50/50 blend of Surlyn® 8940/Surlyn® 9650, preferably having a material hardness of about 86 Shore C.

**[0241]** Surlyn® 8940 is an E/MAA copolymer in which the MAA acid groups have been partially neutralized with sodium ions. Surlyn® 9650 and Surlyn® 9910 are two different grades of E/MAA copolymer in which the MAA acid groups have been partially neutralized with zinc ions. Nucrel® 960 is an E/MAA copolymer resin nominally made with 15 wt % methacrylic acid. Surlyn® 8940, Surlyn® 9650, Surlyn® 9910, and Nucrel® 960 are commercially available from E. I. du Pont de Nemours and Company.

**[0242]** Non-limiting examples of preferred inner cover layer materials are shown in the Examples below.

**[0243]** The inner cover layer material may include a flow modifier, such as, but not limited to, Nucrel® acid copolymer resins, and particularly Nucrel® 960. Nucrel® acid copolymer resins are commercially available from E. I. du Pont de Nemours and Company.

**[0244]** The outer cover layer is preferably formed from a composition comprising polyurethane, polyurea, or a copolymer or hybrid of polyurethane/polyurea. The outer cover layer material may be thermoplastic or thermoset.

**[0245]** In a particular embodiment, the cover is a single layer preferably formed from an ionomeric composition. The single layer cover preferably has a surface hardness of 65 Shore D or less, or 60 Shore D or less, or 45 Shore D or less, or 40 Shore D or less, or from 25 Shore D to 40 Shore

D, or from 30 Shore D to 40 Shore D and a thickness within a range having a lower limit of 0.010 or 0.015 or 0.020 or 0.025 or 0.030 or 0.055 or 0.060 inches and an upper limit of 0.065 or 0.080 or 0.090 or 0.100 or 0.110 or 0.120 or 0.140 inches. The flexural modulus of the cover, as measured by ASTM D6272-98 Procedure B, is preferably 500 psi or greater, or from 500 psi to 150,000 psi.

**[0246]** In another particular embodiment, the cover is a two-layer cover consisting essentially of an inner cover layer and an outer cover layer. The inner cover layer is preferably formed from an ionomeric composition and preferably has a surface hardness of 60 Shore D or greater, or 65 Shore D or greater, or a surface hardness within a range having a lower limit of 30 or 40 or 55 or 60 or 65 Shore D and an upper limit of 66 or 68 or 70 or 75 Shore D, and a thickness within a range having a lower limit of 0.010 or 0.015 or 0.020 or 0.030 inches and an upper limit of 0.035 or 0.040 or 0.045 or 0.050 or 0.055 or 0.075 or 0.080 or 0.100 or 0.110 or 0.120 inches. The inner cover layer composition preferably has a material hardness of 95 Shore C or less, or less than 95 Shore C, or 92 Shore C or less, or 90 Shore C or less, or has a material hardness within a range having a lower limit of 70 or 75 or 80 or 84 or 85 Shore C and an upper limit of 90 or 92 or 95 Shore C. The outer cover layer is preferably formed from a castable or reaction injection moldable polyurethane, polyurea, or copolymer or hybrid of polyurethane/polyurea. Such cover material is preferably thermosetting, but may be thermoplastic. The outer cover layer composition preferably has a material hardness of 85 Shore C or less, or 45 Shore D or less, or 40 Shore D or less, or from 25 Shore D to 40 Shore D, or from 30 Shore D to 40 Shore D. The outer cover layer preferably has a surface hardness within a range having a lower limit of 20 or 30 or 35 or 40 Shore D and an upper limit of 52 or 58 or 60 or 65 or 70 or 72 or 75 Shore D. The outer cover layer preferably has a thickness within a range having a lower limit of 0.010 or 0.015 or 0.025 inches and an upper limit of 0.035 or 0.040 or 0.045 or 0.050 or 0.055 or 0.075 or 0.080 or 0.115 inches. The two-layer cover preferably has an overall thickness within a range having a lower limit of 0.010 or 0.015 or 0.020 or 0.025 or 0.030 or 0.055 or 0.060 inches and an upper limit of 0.065 or 0.075 or 0.080 or 0.090 or 0.100 or 0.110 or 0.120 or 0.140 inches.

**[0247]** In another particular embodiment, the cover is a dual-layer cover comprising an inner cover layer and an outer cover layer. In a particular aspect of this embodiment, the surface hardness of the outer core layer is greater than the material hardness of the inner cover layer. In another particular aspect of this embodiment, the surface hardness of the outer core layer is greater than both the inner cover layer and the outer cover layer. The inner cover layer preferably has a material hardness of 95 Shore C or less, or less than 95 Shore C, or 92 Shore C or less, or 90 Shore C or less, or has a material hardness within a range having a lower limit of 70 or 75 or 80 or 84 or 85 Shore C and an upper limit of 90 or 92 or 95 Shore C. The thickness of the inner cover layer is preferably within a range having a lower limit of 0.010 or 0.015 or 0.020 or 0.030 inches and an upper limit of 0.035 or 0.045 or 0.080 or 0.120 inches. The outer cover layer preferably has a material hardness of 85 Shore C or less. The thickness of the outer cover layer is preferably within a range having a lower limit of 0.010 or 0.015 or 0.025 inches and an upper limit of 0.035 or 0.040 or 0.055 or 0.080 inches.

[0248] A moisture vapor barrier layer is optionally employed between the core and the cover. Moisture vapor barrier layers are further disclosed, for example, in U.S. Pat. Nos. 6,632,147, 6,932,720, 7,004,854, and 7,182,702, the entire disclosures of which are hereby incorporated herein by reference.

[0249] The present invention is not limited by any particular process for forming the golf ball layer(s). It should be understood that the layer(s) can be formed by any suitable technique, including injection molding, compression molding, casting, and reaction injection molding.

[0250] When injection molding is used, the composition is typically in a pelletized or granulated form that can be easily fed into the throat of an injection molding machine wherein it is melted and conveyed via a screw in a heated barrel at temperatures of from 150° F. to 600° F., preferably from 200° F. to 500° F. The molten composition is ultimately injected into a closed mold cavity, which may be cooled, at ambient or at an elevated temperature, but typically the mold is cooled to a temperature of from 50° F. to 70° F. After residing in the closed mold for a time of from 1 second to 300 seconds, preferably from 20 seconds to 120 seconds, the core and/or core plus one or more additional core or cover layers is removed from the mold and either allowed to cool at ambient or reduced temperatures or is placed in a cooling fluid such as water, ice water, dry ice in a solvent, or the like.

[0251] When compression molding is used to form a center, the composition is first formed into a preform or slug of material, typically in a cylindrical or roughly spherical shape at a weight slightly greater than the desired weight of the molded core. Prior to this step, the composition may be first extruded or otherwise melted and forced through a die after which it is cut into a cylindrical preform. It is that preform that is then placed into a compression mold cavity and compressed at a mold temperature of from 150° F. to 400° F., preferably from 250° F. to 350° F., and more preferably from 260° F. to 295° F. When compression molding a core or cover layer of an HNP composition, a half-shell is first formed via injection molding and then a core comprising one or more layers is enclosed within two half shells and then compression molded in a similar manner to the process previously described.

[0252] Reaction injection molding processes are further disclosed, for example, in U.S. Pat. Nos. 6,083,119, 7,338,391, 7,282,169, 7,281,997 and U.S. Patent Application Publication No. 2006/0247073, the entire disclosures of which are hereby incorporated herein by reference.

[0253] Golf balls of the present invention typically have a compression of 120 or less, or a compression within a range having a lower limit of 40 or 50 or 60 or 65 or 75 or 80 or 90 and an upper limit of 95 or 100 or 105 or 110 or 115 or 120. Golf balls of the present invention typically have a COR at 125 ft/s of at least 0.70, preferably at least 0.75, more preferably at least 0.78, and even more preferably at least 0.79.

[0254] In one embodiment, golf balls of the present invention have a moment of inertia ("MOI") of 85 g-cm<sup>2</sup> or less, or 83 g-cm<sup>2</sup> or less. In another embodiment, golf balls of the present invention have an MOI of 86 g-cm<sup>2</sup> or greater, or 87 g-cm<sup>2</sup> or greater. In another embodiment, golf balls of the present invention have an MOI of 70-95 g-cm<sup>2</sup>, preferably 75-93 g-cm<sup>2</sup>, and more preferably 76-90 g-cm<sup>2</sup>.

[0255] MOI is measured on a model MOI-005-104 Moment of Inertia Instrument manufactured by Inertia

Dynamics of Collinsville, CT. The instrument is connected to a PC for communication via a COMM port and is driven by MOI Instrument Software version #1.2.

[0256] Golf balls of the present invention typically have a dimple coverage of 50% or greater, or 60% or greater, or 65% or greater, or 70% or greater, or 75% or greater, or 80% or greater, or 85% or greater, or 90% or greater, or 95% or greater.

[0257] The dimples are not limited to a particular plan view shape, and, in one embodiment, have a plan view shape selected from circular, polygonal, oval, flower-like lobed shape, multi-armed shape, amorphous shape, and annular shape.

[0258] The dimples are not limited to a particular cross-sectional profile shape, and, in one embodiment, have a profile shape selected from spherical, truncated, catenary, multi-radius, saucer, dimple-in-dimple, conical, and bramble.

[0259] The dimples are not limited to a particular dimple arrangement, and, in one embodiment, are arranged in an overall pattern selected from polyhedron-based patterns (e.g., icosahedron, octahedron, dodecahedron, icosidodecahedron, cuboctahedron, and triangular dipyramid), phyllo-taxis-based patterns, spherical tiling patterns, and random arrangements.

[0260] In a particular embodiment, the dimples have a diameter of from 6% to 12% of the ball diameter and a surface depth, as measured from the phantom ball surface over the dimple to the bottom of the dimple, of from 0.3% to 1.0% of the ball diameter. In a particular aspect of this embodiment, the dimples have an edge angle of from 13° to 20°. In another particular aspect of this embodiment, the total dimple volume, defined herein as the space enclosed between the phantom ball surface and the actual ball surface, is from 1.0% to 2.0% of the phantom ball volume. In another particular aspect of this embodiment, the dimple count is from 300 to 500. In another particular aspect of this embodiment, the ball has a diameter of from 1.68 inches to 2.00 inches.

[0261] In another particular embodiment, the dimples have a diameter of from 3% to 14% of the ball diameter, or from 3% to 9% of the ball diameter, and a surface depth, as measured from the phantom ball surface over the dimple to the bottom of the dimple, of from 0.2% to 1.5% of the ball diameter. In a particular aspect of this embodiment, the dimples have an edge angle of from 10° to 25°. In another particular aspect of this embodiment, the total dimple volume, defined herein as the space enclosed between the phantom ball surface and the actual ball surface, is from 0.5% to 3.0% of the phantom ball volume. In another particular aspect of this embodiment, the dimple count is from 300 to 700, or from 500 to 700. In another particular aspect of this embodiment, the ball has a diameter of from 2.00 inches or greater.

[0262] Generally, it may be difficult to define and measure the edge angle and diameter of a dimple due to the indistinct nature of the boundary dividing the undimpled land surface of the ball from the dimple depression. For example, the effects of paint and/or the dimple design itself can cause the junction between the land surface and the dimple sidewall to be indistinct, making the measurement of dimple edge angle and dimple diameter seem somewhat ambiguous. Thus, the following method can be used to define and measure edge angle and dimple diameter. A continuation of the land

surface is constructed above the dimple to define the phantom surface of the ball. A first tangent line, T1, is then constructed at a point on the dimple sidewall that is spaced 0.003 inches radially inward from the phantom surface. T1 intersects the phantom surface at point P1, which defines a nominal dimple edge position. A second tangent line, T2, tangent to the phantom surface at P1, is then constructed. The edge angle is defined as the angle between T1 and T2. The dimple diameter is defined as the distance between P1 and the equivalent point diametrically opposite along the dimple perimeter. Alternatively, the dimple diameter is defined as twice the distance between P1 and the centerline, measured in a direction perpendicular to the centerline. Methods for defining and measuring dimple parameters are further disclosed, for example, in U.S. Pat. No. 6,916,255 to Aoyama et al. and U.S. Pat. No. 8,333,669 to Sullivan et al., the entire disclosures of which are hereby incorporated herein by reference.

**[0263]** The United States Golf Association specifications limit the minimum size of a competition golf ball to 1.680 inches. There is no specification as to the maximum diameter, and golf balls of any size can be used for recreational play. Golf balls of the present invention can have an overall diameter of any size.

**[0264]** In one embodiment, the golf balls of the present invention have an overall diameter of from 1.680 inches to 1.800 inches, or an overall diameter within a range having a lower limit of 1.680 inches and an upper limit of 1.740 inches or 1.760 inches or 1.800 inches.

**[0265]** In another embodiment, the golf balls of the present invention include one-piece, two-piece, and multi-layer golf balls having an overall diameter of greater than 1.68 inches, or 1.69 inches or greater, or greater than 1.69 inches, or 1.70 inches or greater, or greater than 1.70 inches, or 1.73 inches or greater, or greater than 1.73 inches, or 1.75 inches or greater, or greater than 1.75 inches, or 1.78 inches or greater, or greater than 1.78 inches, or 1.80 inches or greater, or greater than 1.80 inches, or 2.00 inches or greater, or greater than 2.00 inches, or 2.50 inches or greater, or greater than 2.50 inches, or 2.75 inches or greater, or greater than 2.75 inches, or 3.00 inches or greater, or greater than 3.00 inches. In a particular aspect of this embodiment, the golf ball comprises a center and a cover, wherein the center has a diameter of 1.50 inches or greater, or 1.55 inches or greater, or 1.60 inches or greater, or 1.62 inches or greater, or 1.64 inches or greater, or 1.65 inches or greater; and the cover, consisting of one or two layers, has an overall thickness of 0.02 inches or greater, or 0.03 inches or greater, or 0.04 inches or greater, or 0.05 inches or greater, or 0.06 inches or greater, or 0.07 inches or greater. In another particular aspect of this embodiment, the golf ball comprises a center, an outer core layer, and a cover; wherein the center has a diameter of 1.10 inches or greater, or 1.20 inches or greater, or 1.25 inches or greater, or 1.30 inches or greater, or 1.40 inches or greater, or 1.50 inches or greater, or 1.60 inches or greater; the outer core layer has a thickness of 0.10 inches or greater, or 0.15 inches or greater, or 0.18 inches or greater, or 0.20 inches or greater, or 0.23 inches or greater, or 0.24 inches or greater, or 0.25 inches or greater; and the cover, consisting of one or two layers, has an overall thickness of 0.01 inches or greater, or 0.02 inches or greater, or 0.03 inches or greater, or 0.04 inches or greater, or 0.05 inches or greater, or 0.06 inches or greater.

**[0266]** In another particular aspect of this embodiment, the golf ball includes a thermoplastic center having a positive hardness gradient of at least 3 Shore C units, or at least 5 Shore C units.

**[0267]** In another particular aspect of this embodiment, the golf ball weighs 46.0 g or less, or the golf ball weighs greater than 46.0 g, or the golf ball has a weight within a range having a lower limit of 40 g or 42 g or 43 g or 45 g and an upper limit of 45.9 g or 46 g or 48 g or 50 g or 55 g or 60 g or 65 g or 70 g or 75 g or 80 g. In another particular aspect of this embodiment, the golf ball is a two-piece or multi-layer golf ball having at least one layer with a reduced specific gravity, such as a foamed center.

**[0268]** In another particular aspect of this embodiment, the golf ball has a COR of 0.600 or greater, or 0.700 or greater, or 0.725 or greater, or 0.800 or greater, or 0.820 or greater, or 0.825 or greater, or greater than 0.825, or 0.850 or greater, or greater than 0.850.

**[0269]** In another particular aspect of this embodiment, the golf ball has a drop rebound wherein the rebound height is 50 inches or greater, or greater than 50 inches, or 60 inches or greater, or greater than 60 inches, or 70 inches or greater, or greater than 70 inches, or 80 inches or greater, or greater than 80 inches, when dropped from a height of 100 inches.

**[0270]** In another particular aspect of this embodiment, golf balls of the present invention have an MOI of 86 g-cm<sup>2</sup> or greater, or 90 g-cm<sup>2</sup> or greater, or 95 g-cm<sup>2</sup> or greater, or 100 g-cm<sup>2</sup> or greater, or 105 g-cm<sup>2</sup> or greater, or 110 g-cm<sup>2</sup> or greater, or 115 g-cm<sup>2</sup> or greater.

**[0271]** In another particular aspect of this embodiment, the golf ball consists essentially of a single layer formed from an HNP composition, optionally selected from relatively soft HNP compositions, relatively hard HNP compositions, low modulus HNP compositions, and high modulus HNP compositions. In another particular aspect of this embodiment, the golf ball comprises a center, an outer core layer, and a cover, wherein at least one of the center and outer core layer is formed from an HNP composition, optionally selected from relatively soft HNP compositions, relatively hard HNP compositions, low modulus HNP compositions, and high modulus HNP compositions. In another particular aspect of this embodiment, the golf ball comprises a center, an outer core layer, and a cover, wherein the center and the outer core layer are formed from HNP compositions, optionally selected from relatively soft HNP compositions, relatively hard HNP compositions, low modulus HNP compositions, and high modulus HNP compositions. In another particular aspect of this embodiment, the golf ball comprises a center, an outer core layer, and a cover, wherein the center is formed from an HNP composition selected from relatively soft HNP compositions and low modulus compositions and the outer core layer is formed from an HNP composition selected from relatively hard HNP compositions and high modulus HNP compositions. In another particular aspect of this embodiment, the golf ball comprises a center, an outer core layer, and a cover, wherein the center is formed from an HNP composition selected from relatively soft HNP compositions and low modulus HNP compositions.

**[0272]** Thermoplastic layers herein may be treated in such a manner as to create a positive or negative hardness gradient. In golf ball layers of the present invention wherein



a thermosetting rubber is used, gradient-producing processes and/or gradient-producing rubber formulation may be employed. Gradient-producing processes and formulations are disclosed more fully, for example, in U.S. patent application Ser. No. 12/048,665, filed on Mar. 14, 2008; Ser. No. 11/829,461, filed on Jul. 27, 2007; Ser. No. 11/772,903, filed Jul. 3, 2007; Ser. No. 11/832,163, filed Aug. 1, 2007; Ser. No. 11/832,197, filed on Aug. 1, 2007; the entire disclosure of each of these references is hereby incorporated herein by reference.

**[0273]** In addition to the materials disclosed above, any of the core or cover layers may comprise one or more of the following materials: thermoplastic elastomer, thermoset elastomer, synthetic rubber, thermoplastic vulcanizate, copolymeric ionomer, terpolymeric ionomer, polycarbonate, polyolefin, polyamide, copolymeric polyamide, polyesters, polyester-amides, polyether-amides, polyvinyl alcohols, acrylonitrile-butadiene-styrene copolymers, polyarylate, polyacrylate, polyphenylene ether, impact-modified polyphenylene ether, high impact polystyrene, diallyl phthalate polymer, metallocene-catalyzed polymers, styrene-acrylonitrile (SAN), olefin-modified SAN, acrylonitrile-styrene-acrylonitrile, styrene-maleic anhydride (S/MA) polymer, styrenic copolymer, functionalized styrenic copolymer, functionalized styrenic terpolymer, styrenic terpolymer, cellulose polymer, liquid crystal polymer (LCP), ethylene-propylene-diene rubber (EPDM), ethylene-vinyl acetate copolymer (EVA), ethylene propylene rubber (EPR), ethylene vinyl acetate, polyurea, and polysiloxane. Suitable polyamides for use as an additional material in compositions disclosed herein also include resins obtained by: (1) polycondensation of (a) a dicarboxylic acid, such as oxalic acid, adipic acid, sebacic acid, terephthalic acid, isophthalic acid or 1,4-cyclohexanedicarboxylic acid, with (b) a diamine, such as ethylenediamine, tetramethylenediamine, pentamethylenediamine, hexamethylenediamine, or decamethylenediamine, 1,4-cyclohexyldiamine or m-xylylenediamine; (2) a ring-opening polymerization of cyclic lactam, such as  $\epsilon$ -caprolactam or  $\omega$ -laurolactam; (3) polycondensation of an aminocarboxylic acid, such as 6-aminocaproic acid, 9-aminononanoic acid, 11-aminoundecanoic acid or 12-aminododecanoic acid; or (4) copolymerization of a cyclic lactam with a dicarboxylic acid and a diamine. Specific examples of suitable polyamides include Nylon 6, Nylon 66, Nylon 610, Nylon 11, Nylon 12, copolymerized Nylon, Nylon MXD6, and Nylon 46.

**[0274]** In embodiments of the present invention wherein at least one layer is formed from a rubber composition, suitable rubber compositions include natural and synthetic rubbers, including, but not limited to, polybutadiene, polyisoprene, ethylene propylene rubber ("EPR"), ethylene propylene diene rubber ("EPDM"), styrenic block copolymer rubbers (such as SI, SIS, SB, SBS, SIBS, and the like, where "S" is styrene, "I" is isobutylene, and "B" is butadiene), butyl rubber, halobutyl rubber, copolymers of isobutylene and para-alkylstyrene, halogenated copolymers of isobutylene and para-alkylstyrene, copolymers of butadiene with acrylonitrile, polychloroprene, alkyl acrylate rubber, chlorinated isoprene rubber, acrylonitrile chlorinated isoprene rubber, and combinations of two or more thereof. Diene rubbers are preferred, particularly polybutadienes and mixtures of polybutadiene with other elastomers, and especially 1,4-polybutadiene having a cis-structure of at least 40%. In a particularly preferred embodiment, the rubber composition

is a reaction product of a diene rubber, a crosslinking agent, a filler, a co-crosslinking agent or free radical initiator, and optionally a cis-to-trans catalyst. The rubber is preferably selected from polybutadiene and styrene-butadiene. The crosslinking agent typically includes a metal salt, such as a zinc-, aluminum-, sodium-, lithium-, nickel-, calcium-, or magnesium salt, of an unsaturated fatty acid or monocarboxylic acid, such as (meth) acrylic acid. Preferred crosslinking agents include zinc acrylate, zinc diacrylate (ZDA), zinc methacrylate, and zinc dimethacrylate (ZDMA), and mixtures thereof. The crosslinking agent is present in an amount sufficient to crosslink a portion of the chains of the polymers in the composition. The crosslinking agent is generally present in the rubber composition in an amount of from 15 to 30 phr, or from 19 to 25 phr, or from 20 to 24 phr. The desired compression may be obtained by adjusting the amount of crosslinking, which can be achieved, for example, by altering the type and amount of crosslinking agent. The free radical initiator can be any known polymerization initiator which decomposes during the cure cycle, including, but not limited to, dicumyl peroxide, 1,1-di-(t-butylperoxy) 3,3,5-trimethyl cyclohexane, a-a bis-(t-butylperoxy) diisopropylbenzene, 2,5-dimethyl-2,5 di-(t-butylperoxy) hexane or di-t-butyl peroxide, and mixtures thereof. The rubber composition optionally contains one or more antioxidants. Antioxidants are compounds that can inhibit or prevent the oxidative degradation of the rubber. Suitable antioxidants include, for example, dihydroquinoline antioxidants, amine type antioxidants, and phenolic type antioxidants. The rubber composition may also contain one or more fillers to adjust the density and/or specific gravity of the core or cover. Fillers are typically polymeric or mineral particles. Exemplary fillers include precipitated hydrated silica, clay, talc, asbestos, glass fibers, aramid fibers, mica, calcium metasilicate, barium sulfate, zinc sulfide, lithopone, silicates, silicon carbide, diatomaceous earth, polyvinyl chloride, carbonates (e.g., calcium carbonate and magnesium carbonate), metals (e.g., titanium, tungsten, aluminum, bismuth, nickel, molybdenum, iron, lead, copper, boron, cobalt, beryllium, zinc, and tin), metal alloys (e.g., steel, brass, bronze, boron carbide whiskers, and tungsten carbide whiskers), metal oxides (e.g., zinc oxide, iron oxide, aluminum oxide, titanium oxide, magnesium oxide, and zirconium oxide), particulate carbonaceous materials (e.g., graphite, carbon black, cotton flock, natural bitumen, cellulose flock, and leather fiber), microballoons (e.g., glass and ceramic), fly ash, regrind, nanofillers and combinations thereof. The rubber composition may also contain one or more additives selected from free radical scavengers, accelerators, scorch retarders, coloring agents, fluorescent agents, chemical blowing and foaming agents, defoaming agents, stabilizers, softening agents, impact modifiers, plasticizers, and the like. The rubber composition may also contain a soft and fast agent, such as those disclosed in U.S. patent application Ser. No. 11/972,240, the entire disclosure of which is hereby incorporated herein by reference. Examples of commercially available polybutadienes suitable for use in forming golf ball core layers of the present invention include, but are not limited to, Buna CB23, commercially available from LANXESS Corporation; SE BR-1220, commercially available from The Dow Chemical Company; Europrene® NEO-CIS® BR 40 and BR 60, commercially available from Polimeri Europa; UBEPOL-BR® rubbers, commercially available from UBE Industries, Ltd.; and BR 01 commer-

cially available from Japan Synthetic Rubber Co., Ltd. Suitable types and amounts of rubber, crosslinking agent, filler, co-crosslinking agent, initiator and additives are more fully described in, for example, U.S. Patent Application Publication No. 2004/0214661, 2003/0144087, and 2003/0225197, and U.S. Pat. Nos. 6,566,483, 6,695,718, and 6,939,907, the entire disclosures of which are hereby incorporated herein by reference.

**[0275]** In embodiments of the present invention wherein at least one layer is formed from a conventional HNP composition, suitable HNP compositions comprise an HNP and optionally additives, fillers, and/or melt flow modifiers. Suitable HNPs are salts of homopolymers and copolymers of  $\alpha,\beta$ -ethylenically unsaturated mono- or dicarboxylic acids, and combinations thereof, optionally including a softening monomer. The acid polymer is neutralized to 70% or higher, including up to 100%, with a suitable cation source. Suitable additives and fillers include, for example, blowing and foaming agents, optical brighteners, coloring agents, fluorescent agents, whitening agents, UV absorbers, light stabilizers, defoaming agents, processing aids, mica, talc, nanofillers, antioxidants, stabilizers, softening agents, fragrance components, plasticizers, impact modifiers, acid copolymer wax, surfactants; inorganic fillers, such as zinc oxide, titanium dioxide, tin oxide, calcium oxide, magnesium oxide, barium sulfate, zinc sulfate, calcium carbonate, zinc carbonate, barium carbonate, mica, talc, clay, silica, lead silicate, and the like; high specific gravity metal powder fillers, such as tungsten powder, molybdenum powder, and the like; regrind, i.e., core material that is ground and recycled; and nano-fillers. Suitable melt flow modifiers include, for example, fatty acids and salts thereof, polyamides, polyesters, polyacrylates, polyurethanes, polyethers, polyureas, polyhydric alcohols, and combinations thereof. Suitable HNP compositions also include blends of HNPs with partially neutralized ionomers as disclosed, for example, in U.S. Patent Application Publication No. 2006/0128904, the entire disclosure of which is hereby incorporated herein by reference, and blends of HNPs with additional thermoplastic and thermoset materials, including, but not limited to, ionomers, acid copolymers, engineering thermoplastics, fatty acid/salt-based highly neutralized polymers, polybutadienes, polyurethanes, polyesters, thermoplastic elastomers, and other conventional polymeric materials. Suitable HNP compositions are further disclosed, for example, in U.S. Pat. Nos. 6,653,382, 6,756,436, 6,777,472, 6,894,098, 6,919,393, and 6,953,820, the entire disclosures of which are hereby incorporated herein by reference.

**[0276]** Other preferred materials suitable for use as an additional material in golf ball compositions disclosed herein include Skype1 polyester elastomers, commercially available from SK Chemicals of South Korea; Septon® diblock and triblock copolymers, commercially available from Kuraray Corporation of Kurashiki, Japan; and Kraton® diblock and triblock copolymers, commercially available from Kraton Polymers LLC of Houston, Texas.

**[0277]** Ionomers are also well suited for blending with compositions disclosed herein. Suitable ionomeric polymers include  $\alpha$ -olefin/unsaturated carboxylic acid copolymer- or terpolymer-type ionomeric resins. Copolymeric ionomers are obtained by neutralizing at least a portion of the carboxylic groups in a copolymer of an  $\alpha$ -olefin and an  $\alpha,\beta$ -unsaturated carboxylic acid having from 3 to 8 carbon

atoms, with a metal ion. Terpolymeric ionomers are obtained by neutralizing at least a portion of the carboxylic groups in a terpolymer of an  $\alpha$ -olefin, an  $\alpha,\beta$ -unsaturated carboxylic acid having from 3 to 8 carbon atoms, and an  $\alpha,\beta$ -unsaturated carboxylate having from 2 to 22 carbon atoms, with a metal ion. Examples of suitable  $\alpha$ -olefins for copolymeric and terpolymeric ionomers include ethylene, propylene, 1-butene, and 1-hexene. Examples of suitable unsaturated carboxylic acids for copolymeric and terpolymeric ionomers include acrylic, methacrylic, ethacrylic,  $\alpha$ -chloroacrylic, crotonic, maleic, fumaric, and itaconic acid. Copolymeric and terpolymeric ionomers include ionomers having varied acid contents and degrees of acid neutralization, neutralized by monovalent or bivalent cations as disclosed herein. Examples of commercially available ionomers suitable for blending with compositions disclosed herein include Surlyn® ionomer resins, commercially available from E. I. du Pont de Nemours and Company, and Iotek® ionomers, commercially available from ExxonMobil Chemical Company.

**[0278]** Silicone materials are also well suited for blending with compositions disclosed herein. Suitable silicone materials include monomers, oligomers, prepolymers, and polymers, with or without adding reinforcing filler. One type of silicone material that is suitable can incorporate at least 1 alkenyl group having at least 2 carbon atoms in their molecules. Examples of these alkenyl groups include, but are not limited to, vinyl, allyl, butenyl, pentenyl, hexenyl, and decenyl. The alkenyl functionality can be located at any location of the silicone structure, including one or both terminals of the structure. The remaining (i.e., non-alkenyl) silicon-bonded organic groups in this component are independently selected from hydrocarbon or halogenated hydrocarbon groups that contain no aliphatic unsaturation. Non-limiting examples of these include: alkyl groups, such as methyl, ethyl, propyl, butyl, pentyl, and hexyl; cycloalkyl groups, such as cyclohexyl and cycloheptyl; aryl groups, such as phenyl, tolyl, and xylyl; aralkyl groups, such as benzyl and phenethyl; and halogenated alkyl groups, such as 3,3,3-trifluoropropyl and chloromethyl. Another type of suitable silicone material is one having hydrocarbon groups that lack aliphatic unsaturation. Specific examples include: trimethylsiloxy-*end*-blocked dimethylsiloxane-methylhexenylsiloxane copolymers; dimethylhexenylsiloxy-*end*-blocked dimethylsiloxane-methylhexenylsiloxane copolymers; trimethylsiloxy-*end*-blocked dimethylsiloxane-methylvinylsiloxane copolymers; trimethylsiloxy-*end*-blocked methylphenylsiloxane-dimethylsiloxane-methylvinylsiloxane copolymers; dimethylvinylsiloxy-*end*-blocked dimethylpolysiloxanes; dimethylvinylsiloxy-*end*-blocked dimethylsiloxane-methylvinylsiloxane copolymers; dimethylvinylsiloxy-*end*-blocked methylphenylpolysiloxanes; dimethylvinylsiloxy-*end*-blocked methylphenylsiloxane-dimethylsiloxane-methylvinylsiloxane copolymers; and the copolymers listed above wherein at least one group is dimethylhydroxysiloxy. Examples of commercially available silicones suitable for blending with compositions disclosed herein include Silastic® silicone rubber, commercially available from Dow Corning Corporation of Midland, Michigan; Blensil® silicone rubber, commercially available from General Electric Company of Waterford, New York; and Elastosil® silicones, commercially available from Wacker Chemie AG of Germany.

**[0279]** Other types of copolymers can also be added to the golf ball compositions disclosed herein. For example, suitable copolymers comprising epoxy monomers include styrene-butadiene-styrene block copolymers in which the polybutadiene block contains an epoxy group, and styrene-isoprene-styrene block copolymers in which the polyisoprene block contains epoxy. Examples of commercially available epoxy functionalized copolymers include ESBS A1005, ESBS A1010, ESBS A1020, ESBS AT018, and ESBS AT019 epoxidized styrene-butadiene-styrene block copolymers, commercially available from Daicel Chemical Industries, Ltd. of Japan.

**[0280]** Ionomeric compositions used to form golf ball layers of the present invention can be blended with non-ionic thermoplastic resins, particularly to manipulate product properties. Examples of suitable non-ionic thermoplastic resins include, but are not limited to, polyurethane, polyether-ester, poly-amide-ether, polyether-urea, Pebax® thermoplastic polyether block amides commercially available from Arkema Inc., styrene-butadiene-styrene block copolymers, styrene(ethylene-butylene)-styrene block copolymers, polyamides, polyesters, polyolefins (e.g., polyethylene, polypropylene, ethylene-propylene copolymers, ethylene-(meth)acrylate, ethylene-(meth)acrylic acid, functionalized polymers with maleic anhydride grafting, epoxidation, etc., elastomers (e.g., EPDM, metallocene-catalyzed polyethylene) and ground powders of the thermoset elastomers.

**[0281]** Also suitable for forming the center and outer core layers are the compositions having high COR when formed into solid spheres disclosed in U.S. Patent Application Publication No. 2003/0130434 and U.S. Pat. No. 6,653,382, the entire disclosures of which are hereby incorporated herein by reference. Reference is also made to U.S. Patent Application Publication No. 2003/0144087 for various ball constructions and materials that can be used in golf ball core, intermediate, and cover layers.

**[0282]** Additional materials suitable for forming the core layers include the core compositions disclosed in U.S. Pat. No. 7,300,364, the entire disclosure of which is hereby incorporated herein by reference. For example, suitable core materials include HNPs neutralized with organic fatty acids and salts thereof, metal cations, or a combination of both. In addition to HNPs neutralized with organic fatty acids and salts thereof, core compositions may comprise at least one rubber material having a resilience index of at least about 40. Preferably the resilience index is at least about 50. Polymers that produce resilient golf balls and, therefore, are suitable for the present invention, include but are not limited to CB23, CB22, commercially available from Bayer Corp. of Orange, TX, BR60, commercially available from Enichem of Italy, and 1207G, commercially available from Goodyear Corp. of Akron, OH. Additionally, the unvulcanized rubber, such as polybutadiene, in golf balls prepared according to the invention typically has a Mooney viscosity of between about 40 and about 80, more preferably, between about 45 and about 65, and most preferably, between about 45 and about 55. Mooney viscosity is typically measured according to ASTM-D1646.

**[0283]** In addition to the above materials, the center can be formed from a low deformation material selected from metal, rigid plastics, polymers reinforced with high strength organic or inorganic fillers or fibers, and blends and composites thereof. Suitable low deformation materials also include those disclosed in U.S. Patent Application Publica-

tion No. 2005/0250600, the entire disclosure of which is hereby incorporated herein by reference.

## EXAMPLES

**[0284]** It should be understood that the examples below are for illustrative purposes only. In no manner is the present invention limited to the specific disclosures herein.

### Additional Examples of Suitable HNPs

**[0285]** The HNPs of Table 3 below have been found to be particularly useful as the relatively soft/low modulus HNP and/or the relatively hard/high modulus HNP of the present invention.

TABLE 3

Example	cation source	Flexural Modulus*, psi	Hardness**, Shore C (18 day)	Hardness**, Shore D (annealed)
1	Ca/Mg	71,600	88	57
2	Ca/Li	70,300	89	58
3	Ca	70,100	92	60
4	Ca/Zn	60,400	88	58
5	Mg	38,300	84	52
6	Mg	27,600	84	52
7	Mg	16,300	78	45
8	Mg	10,600	70	40
9	Mg	10,400	69	39

\*Flexural modulus was measured according to ASTM D790-03 Procedure B.

\*\*Hardness was measured according to ASTM D2240.

**[0286]** In embodiments of the present invention directed to a golf ball having center formed from a relatively soft HNP composition, Examples 6-9 are particularly suitable for use as the relatively soft HNP composition.

**[0287]** In embodiments of the present invention directed to a golf ball having an outer core layer formed from a relatively soft HNP composition, Examples 5-9 are particularly suitable for use as the relatively soft HNP composition.

**[0288]** In embodiments of the present invention directed to a golf ball having a center formed from a relatively hard HNP composition, Examples 1-6 are particularly suitable for use as the relatively hard HNP composition.

**[0289]** In embodiments of the present invention directed to a golf ball having an outer core layer formed from a relatively hard HNP composition, Examples 1-4 are particularly suitable for use as the relatively hard HNP composition.

**[0290]** In embodiments of the present invention directed to a golf ball having center formed from a low modulus HNP composition, Examples 6-9 are particularly suitable for use as the low modulus HNP composition.

**[0291]** In embodiments of the present invention directed to a golf ball having an outer core layer formed from a low modulus HNP composition, Examples 5-9 are particularly suitable for use as the low modulus HNP composition.

**[0292]** In embodiments of the present invention directed to a golf ball having a center formed from a high modulus HNP composition, Examples 1-6 are particularly suitable for use as the high modulus HNP composition.

**[0293]** In embodiments of the present invention directed to a golf ball having an outer core layer formed from a high modulus HNP composition, Examples 1-4 are particularly suitable for use as the high modulus HNP composition.

### Additional Examples of Suitable Ionomeric Cover Layer Compositions

**[0294]** Twelve ionomeric inner cover layer compositions according to the present invention were prepared by melt blending Surlyn® 8150 and Fusabond® 572D in a twin screw extruder, at a temperature of at least 450° F. (230° C.). The relative amounts of each component used are indicated in Table 4 below.

**[0295]** Flex bars of each blend composition were formed and evaluated for hardness according to ASTM D2240 following 10 days of aging at 50% relative humidity and 23° C. The results are reported in Table 4 below:

TABLE 4

Example	Surlyn® 8150, wt %	Fusabond® 572D, wt %	Shore C Hardness at 10 Days
1	89	11	91.2
2	84	16	89.8
3	84	16	90.4
4	84	16	89.6
5	81	19	88.9
6	80	20	89.1
7	78	22	88.1
8	76	24	87.6
9	76	24	87.2
10	73	27	86.6
11	71	29	86.7
12	67	33	84.0

**[0296]** The following commercially available materials were used in the below examples:

**[0297]** A-C® 5120 ethylene acrylic acid copolymer with an acrylic acid content of 15%;

**[0298]** A-C® 5180 ethylene acrylic acid copolymer with an acrylic acid content of 20%;

**[0299]** A-C® 395 high density oxidized polyethylene homopolymer, and

**[0300]** A-C® 575 ethylene maleic anhydride copolymer, commercially available from Honeywell;

**[0301]** CB23 high-cis neodymium-catalyzed polybutadiene rubber, commercially available from Lanxess Corporation;

**[0302]** CA1700 Soya fatty acid, CA1726 linoleic acid, and CA1725 conjugated linoleic acid, commercially available from Chemical Associates;

**[0303]** Century® 1107 highly purified isostearic acid mixture of branched and straight-chain C18 fatty acid, commercially available from Arizona Chemical;

**[0304]** Clarix® 011370-01 ethylene acrylic acid copolymer with an acrylic acid content of 13% and

**[0305]** Clarix® 011536-01 ethylene acrylic acid copolymer with an acrylic acid content of 15%, commercially available from A. Schulman Inc.;

**[0306]** Elvaloy® AC 1224 ethylene-methyl acrylate copolymer with a methyl acrylate content of 24 wt %;

**[0307]** Elvaloy® AC 1335 ethylene-methyl acrylate copolymer with a methyl acrylate content of 35 wt %;

**[0308]** Elvaloy® AC 2116 ethylene-ethyl acrylate copolymer with an ethyl acrylate content of 16 wt %;

**[0309]** Elvaloy® AC 3427 ethylene-butyl acrylate copolymer having a butyl acrylate content of 27 wt %, and

**[0310]** Elvaloy® AC 34035 ethylene-butyl acrylate copolymer having a butyl acrylate content of 35 wt %, commercially available from E. I. du Pont de Nemours and Company;

**[0311]** Escor® AT-320 ethylene acid terpolymer, commercially available from ExxonMobil Chemical Company;

**[0312]** Exxelor® VA 1803 amorphous ethylene copolymer functionalized with maleic anhydride, commercially available from ExxonMobil Chemical Company;

**[0313]** Fusabond® N525 metallocene-catalyzed polyethylene,

**[0314]** Fusabond® N416 chemically modified ethylene elastomer,

**[0315]** Fusabond® C190 anhydride modified ethylene vinyl acetate copolymer, and

**[0316]** Fusabond® P614 functionalized polypropylene, commercially available from E. I. du Pont de Nemours and Company;

**[0317]** Hytel® 3078 very low modulus thermoplastic polyester elastomer, commercially available from E. I. du Pont de Nemours and Company;

**[0318]** Kraton® FG 1901 GT linear triblock copolymer based on styrene and ethylene/butylene with a polystyrene content of 30% and

**[0319]** Kraton® FG1924GT linear triblock copolymer based on styrene and ethylene/butylene with a polystyrene content of 13%, commercially available from Kraton Performance Polymers Inc.;

**[0320]** Lotader® 4603, 4700 and 4720, random copolymers of ethylene, acrylic ester and maleic anhydride, commercially available from Arkema Corporation;

**[0321]** Nordel® IP 4770 high molecular weight semi-crystalline EPDM rubber, commercially available from The Dow Chemical Company;

**[0322]** Nucrel® 9-1, Nucrel® 599, Nucrel® 960, Nucrel® 0407, Nucrel® 0609, Nucrel® 1214, Nucrel® 2906, Nucrel® 2940, Nucrel® 30707, Nucrel® 31001, and

**[0323]** Nucrel® AE acid copolymers, commercially available from E. I. du Pont de Nemours and Company;

**[0324]** Primacor® 3150, 3330, 59801, and 59901 acid copolymers, commercially available from The Dow Chemical Company;

**[0325]** Royaltuf® 498 maleic anhydride modified polyolefin based on an amorphous EPDM, commercially available from Chemtura Corporation;

**[0326]** Sylfat® FA2 tall oil fatty acid, commercially available from Arizona Chemical;

**[0327]** Vamac® G terpolymer of ethylene, methylacrylate and a cure site monomer, commercially available from E. I. du Pont de Nemours and Company; and

**[0328]** XUS 60758.08L ethylene acrylic acid copolymer with an acrylic acid content of 13.5%, commercially available from The Dow Chemical Company.

**[0329]** Various compositions were melt blended using components as given in Table 5 below. The compositions were neutralized by adding a cation source in an amount sufficient to neutralize, theoretically, 110% of the acid groups present in components 1 and 3, except for example 72, in which the cation source was added in an amount sufficient to neutralize 75% of the acid groups. Magnesium hydroxide was used as the cation source, except for example 68, in which magnesium hydroxide and sodium hydroxide were used in an equivalent ratio of 4:1. In addition to

components 1-3 and the cation source, example 71 contains ethyl oleate plasticizer.

[0330] The relative amounts of component 1 and component 2 used are indicated in Table 5 below, and are reported

in wt %, based on the combined weight of components 1 and 2. The relative amounts of component 3 used are indicated in Table 5 below, and are reported in wt %, based on the total weight of the composition.

TABLE 5

Example	Component 1	wt %	Component 2	wt %	Component 3	wt %
1	Primacor 5980I	78	Lotader 4603	22	magnesium oleate	41.6
2	Primacor 5980I	84	Elvaloy AC 1335	16	magnesium oleate	41.6
3	Primacor 5980I	78	Elvaloy AC 3427	22	magnesium oleate	41.6
4	Primacor 5980I	78	Elvaloy AC 1335	22	magnesium oleate	41.6
5	Primacor 5980I	78	Elvaloy AC 1224	22	magnesium oleate	41.6
6	Primacor 5980I	78	Lotader 4720	22	magnesium oleate	41.6
7	Primacor 5980I	85	Vamac G	15	magnesium oleate	41.6
8	Primacor 5980I	90	Vamac G	10	magnesium oleate	41.6
8.1	Primacor 5990I	90	Fusabond 614	10	magnesium oleate	41.6
9	Primacor 5980I	78	Vamac G	22	magnesium oleate	41.6
10	Primacor 5980I	75	Lotader 4720	25	magnesium oleate	41.6
11	Primacor 5980I	55	Elvaloy AC 3427	45	magnesium oleate	41.6
12	Primacor 5980I	55	Elvaloy AC 1335	45	magnesium oleate	41.6
12.1	Primacor 5980I	55	Elvaloy AC 34035	45	magnesium oleate	41.6
13	Primacor 5980I	55	Elvaloy AC 2116	45	magnesium oleate	41.6
14	Primacor 5980I	78	Elvaloy AC 34035	22	magnesium oleate	41.6
14.1	Primacor 5990I	80	Elvaloy AC 34035	20	magnesium oleate	41.6
15	Primacor 5980I	34	Elvaloy AC 34035	66	magnesium oleate	41.6
16	Primacor 5980I	58	Vamac G	42	magnesium oleate	41.6
17	Primacor 5990I	80	Fusabond 416	20	magnesium oleate	41.6
18	Primacor 5980I	100	—	—	magnesium oleate	41.6
19	Primacor 5980I	78	Fusabond 416	22	magnesium oleate	41.6
20	Primacor 5990I	100	—	—	magnesium oleate	41.6
21	Primacor 5990I	20	Fusabond 416	80	magnesium oleate	41.6
21.1	Primacor 5990I	20	Fusabond 416	80	magnesium oleate	31.2
21.2	Primacor 5990I	20	Fusabond 416	80	magnesium oleate	20.8
22	Clarix 011370	30.7	Fusabond 416	69.3	magnesium oleate	41.6
23	Primacor 5990I	20	Royaltuf 498	80	magnesium oleate	41.6
24	Primacor 5990I	80	Royaltuf 498	20	magnesium oleate	41.6
25	Primacor 5990I	80	Kraton FG1924GT	20	magnesium oleate	41.6
26	Primacor 5990I	20	Kraton FG1924GT	80	magnesium oleate	41.6
27	Nucrel 30707	57	Fusabond 416	43	magnesium oleate	41.6
28	Primacor 5990I	80	Hytrel 3078	20	magnesium oleate	41.6
29	Primacor 5990I	20	Hytrel 3078	80	magnesium oleate	41.6
30	Primacor 5980I	26.8	Elvaloy AC 34035	73.2	magnesium oleate	41.6
31	Primacor 5980I	26.8	Lotader 4603	73.2	magnesium oleate	41.6
32	Primacor 5980I	26.8	Elvaloy AC 2116	73.2	magnesium oleate	41.6
33	Escor AT-320	30	Elvaloy AC 34035	52	magnesium oleate	41.6
34	Primacor 5980I	18	—	—	—	—
34	Nucrel 30707	78.5	Elvaloy AC 34035	21.5	magnesium oleate	41.6
35	Nucrel 30707	78.5	Fusabond 416	21.5	magnesium oleate	41.6
36	Primacor 5980I	26.8	Fusabond 416	73.2	magnesium oleate	41.6
37	Primacor 5980I	19.5	Fusabond N525	80.5	magnesium oleate	41.6
38	Clarix 011536-01	26.5	Fusabond N525	73.5	magnesium oleate	41.6
39	Clarix 011370-01	31	Fusabond N525	69	magnesium oleate	41.6
39.1	XUS 60758.08L	29.5	Fusabond N525	70.5	magnesium oleate	41.6
40	Nucrel 31001	42.5	Fusabond N525	57.5	magnesium oleate	41.6
41	Nucrel 30707	57.5	Fusabond N525	42.5	magnesium oleate	41.6
42	Escor AT-320	66.5	Fusabond N525	33.5	magnesium oleate	41.6
43	Nucrel 2906/2940	21	Fusabond N525	79	magnesium oleate	41.6
44	Nucrel 960	26.5	Fusabond N525	73.5	magnesium oleate	41.6
45	Nucrel 1214	33	Fusabond N525	67	magnesium oleate	41.6
46	Nucrel 599	40	Fusabond N525	60	magnesium oleate	41.6
47	Nucrel 9-1	44.5	Fusabond N525	55.5	magnesium oleate	41.6
48	Nucrel 0609	67	Fusabond N525	33	magnesium oleate	41.6
49	Nucrel 0407	100	—	—	magnesium oleate	41.6
50	Primacor 5980I	90	Fusabond N525	10	magnesium oleate	41.6
51	Primacor 5980I	80	Fusabond N525	20	magnesium oleate	41.6
52	Primacor 5980I	70	Fusabond N525	30	magnesium oleate	41.6
53	Primacor 5980I	60	Fusabond N525	40	magnesium oleate	41.6
54	Primacor 5980I	50	Fusabond N525	50	magnesium oleate	41.6
55	Primacor 5980I	40	Fusabond N525	60	magnesium oleate	41.6
56	Primacor 5980I	30	Fusabond N525	70	magnesium oleate	41.6
57	Primacor 5980I	20	Fusabond N525	80	magnesium oleate	41.6
58	Primacor 5980I	10	Fusabond N525	90	magnesium oleate	41.6

TABLE 5-continued

Example	Component 1	wt %	Component 2	wt %	Component 3	wt %
59			Fusabond N525	100	magnesium oleate	41.6
60	Nucrel 0609	40	Fusabond N525	20	magnesium oleate	41.6
	Nucrel 0407	40				
61	Nucrel AE	100	—	—	magnesium oleate	41.6
62	Primacor 5980I	30	Fusabond N525	70	CA1700 soya fatty acid magnesium salt	41.6
63	Primacor 5980I	30	Fusabond N525	70	CA1726 linoleic acid magnesium salt	41.6
64	Primacor 5980I	30	Fusabond N525	70	CA1725 conjugated linoleic acid magnesium salt	41.6
65	Primacor 5980I	30	Fusabond N525	70	Century 1107 isostearic acid magnesium salt	41.6
66	A-C 5120	73.3	Lotader 4700	26.7	oleic acid magnesium salt	41.6
67	A-C 5120	73.3	Elvaloy 34035	26.7	oleic acid magnesium salt	41.6
68	Primacor 5980I	78.3	Lotader 4700	21.7	oleic acid magnesium salt and sodium salt	41.6
69	Primacor 5980I	47	Elvaloy AC34035	13	—	—
	A-C 5180	40				
70	Primacor 5980I	30	Fusabond N525	70	Sylfat FA2 magnesium salt	41.6
71	Primacor 5980I	30	Fusabond N525	70	oleic acid magnesium salt	31.2 10
72	Primacor 5980I	80	Fusabond N525	20	ethyl oleate sebacic acid magnesium salt	41.6
73	Primacor 5980I	60	—	—	—	—
	A-C 5180	40				
74	Primacor 5980I	78.3	—	—	oleic acid magnesium salt	41.6
	A-C 575	21.7				
75	Primacor 5980I	78.3	Exxelor VA 1803	21.7	oleic acid magnesium salt	41.6
76	Primacor 5980I	78.3	A-C 395	21.7	oleic acid magnesium salt	41.6
77	Primacor 5980I	78.3	Fusabond C190	21.7	oleic acid magnesium salt	41.6
78	Primacor 5980I	30	Kraton FG 1901	70	oleic acid magnesium salt	41.6
79	Primacor 5980I	30	Royaltuf 498	70	oleic acid magnesium salt	41.6
80	A-C 5120	40	Fusabond N525	60	oleic acid magnesium salt	41.6
81	Primacor 5980I	30	Fusabond N525	70	erucic acid magnesium salt	41.6
82	Primacor 5980I	30	CB23	70	oleic acid magnesium salt	41.6
83	Primacor 5980I	30	Nordel IP 4770	70	oleic acid magnesium salt	41.6
84	Primacor 5980I	48	Fusabond N525	20	oleic acid magnesium salt	41.6
	A-C 5180	32				
85	Nucrel 2806	22.2	Fusabond N525	77.8	oleic acid magnesium salt	41.6
86	Primacor 3330	61.5	Fusabond N525	38.5	oleic acid magnesium salt	41.6
87	Primacor 3330	45.5	Fusabond N525	20	oleic acid magnesium salt	41.6
	Primacor 3150	34.5				
88	Primacor 3330	28.5	—	—	oleic acid magnesium salt	41.6
	Primacor 3150	71.5				
89	Primacor 3150	67	Fusabond N525	33	oleic acid magnesium salt	41.6
90	Primacor 5980I	55	Elvaloy AC 34035	45	oleic acid magnesium salt and ethyl oleate	31.2 10

[0331] Solid spheres of each composition were injection molded, and the solid sphere COR, compression, Shore D hardness, and Shore C hardness of the resulting spheres were measured after two weeks. The results are reported in Table 6 below. The surface hardness of a sphere is obtained from the average of a number of measurements taken from opposing hemispheres, taking care to avoid making measurements on the parting line of the sphere or on surface defects, such as holes or protrusions. Hardness measurements are made pursuant to ASTM D-2240 “Indentation Hardness of Rubber and Plastic by Means of a Durometer.” Because of the curved surface, care must be taken to insure that the sphere is centered under the durometer indenter before a surface hardness reading is obtained. A calibrated, digital durometer, capable of reading to 0.1 hardness units is used for all hardness measurements and is set to record the maximum hardness reading obtained for each measurement. The digital durometer must be attached to, and its foot made parallel to, the base of an automatic stand. The weight on the durometer and attack rate conform to ASTM D-2240.

TABLE 6

Ex.	Solid Sphere COR	Solid Sphere Compression	Solid Sphere Shore D	Solid Sphere Shore C
1	0.845	120	59.6	89.2
2	*	*	*	*
3	0.871	117	57.7	88.6
4	0.867	122	63.7	90.6
5	0.866	119	62.8	89.9
6	*	*	*	*
7	*	*	*	*
8	*	*	*	*
8.1	0.869	127	65.3	92.9
9	*	*	*	*
10	*	*	*	*
11	*	*	*	*
12	0.856	101	55.7	82.4
12.1	0.857	105	53.2	81.3
13	*	*	*	*
14	0.873	122	64.0	91.1
14.1	*	*	*	*
15	*	*	*	*
16	*	*	*	*
17	0.878	117	60.1	89.4
18	0.853	135	67.6	94.9
19	*	*	*	*
20	0.857	131	66.2	94.4
21	0.752	26	34.8	57.1
21.1	0.729	9	34.3	56.3
21.2	0.720	2	33.8	55.2
22	*	*	*	*
23	*	*	*	*
24	*	*	*	*
25	*	*	*	*
26	*	*	*	*
27	*	*	*	*
28	*	*	*	*
29	*	*	*	*
30	**	66	42.7	65.5
31	0.730	67	45.6	68.8
32	**	100	52.4	78.2
33	0.760	64	43.6	64.5
34	0.814	91	52.8	80.4
35	*	*	*	*
36	*	*	*	*
37	*	*	*	*
38	*	*	*	*
39	*	*	*	*
39.1	*	*	*	*
40	*	*	*	*
41	*	*	*	*

TABLE 6-continued

Ex.	Solid Sphere COR	Solid Sphere Compression	Solid Sphere Shore D	Solid Sphere Shore C
42	*	*	*	*
43	*	*	*	*
44	*	*	*	*
45	*	*	*	*
46	*	*	*	*
47	*	*	*	*
48	*	*	*	*
49	*	*	*	*
50	*	*	*	*
51	0.873	121	61.5	90.2
52	0.870	116	60.4	88.2
53	0.865	107	57.7	84.4
54	0.853	97	53.9	80.2
55	0.837	82	50.1	75.5
56	0.818	66	45.6	70.7
57	0.787	45	41.3	64.7
58	0.768	26	35.9	57.3
59	*	*	*	*
60	*	*	*	*
61	*	*	*	*
62	*	*	*	*
63	*	*	*	*
64	*	*	*	*
65	*	*	*	*
66	*	*	*	*
67	*	*	*	*
68	*	*	*	*
69	*	*	*	*
70	*	*	*	*
71	*	*	*	*
72	*	*	*	*
73	*	*	*	*
74	*	*	*	*
75	*	*	*	*
76	*	*	*	*
77	*	*	*	*
78	*	*	*	*
79	*	*	*	*
80	*	*	*	*
81	*	*	*	*
82	*	*	*	*
83	*	*	*	*
84	*	*	*	*
85	*	*	*	*
86	*	*	*	*
87	*	*	*	*
88	*	*	*	*
89	*	*	*	*
90	*	*	*	*

\* not measured

\*\* sphere broke during measurement

Prophetic Example

[0332] The examples below are for illustrative purposes only. In no manner is the present invention limited to the specific disclosures therein.

[0333] The following polymer, additive, and filler materials were used in the below examples:

[0334] HPF 2000, AD 1035, AD 1022, Surlyn® 7940, Surlyn® 8940, Surlyn® 8150, Surlyn® 9120, and Surlyn® 9910, ionomeric materials, commercially available from E. I. du Pont de Nemours and Company;

[0335] Fusabond® 525D metallocene-catalyzed polyethylene, commercially available from E. I. du Pont de Nemours and Company;

[0336] Buna CB 23 neodymium-catalyzed polybutadiene rubber, commercially available from Lanxess Corporation; and

[0337] Expancel® microspheres, commercially available from AkzoNobel.

[0338] Two-layer golf balls of the present invention can be made by molding spheres of a first ionomer composition to form a core and enclosing the core in a cover layer formed from a second ionomer composition to form the two-layer golf ball. Examples of ionomer compositions particularly suitable for use in forming the core and cover layer include, but are not limited to, those given in Table 7 below.

TABLE 7

	Example 1	Example 2
<b>Core Composition</b>		
HPF 2000 (parts)	0	50
AD 1035 (parts)	100	0
Fusabond ® 525D (parts)	0	50
Core Composition Density (g/cm <sup>3</sup> )	0.97	0.92
<b>Core Properties</b>		
Diameter (inches)	1.62	1.65
Weight (oz)	35.5	35.5
Compression (Atti)	60	35
Deflection (130-10 kgf)	3.8	4.6
COR	0.822	0.788
Center Hardness (Shore C)	64	55
Surface Hardness (Shore C)	70	60
<b>Cover Composition</b>		
Surlyn ® 7940 (parts)	50	0
Surlyn ® 8940 (parts)	50	0
Surlyn ® 8150	0	50
Surlyn ® 9120	0	50
Color Masterbatch	5	5
<b>Ball Properties</b>		
Diameter (inches)	1.765	1.79
Weight (oz)	45.5	45.6
Compression (Atti)	78	53
Deflection (130-10 kgf)	3.2	3.9
COR	0.832	0.814
Surface Hardness (Shore D)	69	72
MOI (oz · in <sup>2</sup> )	0.501	0.523

[0339] Three-layer golf balls of the present invention can be made by molding spheres of a polybutadiene composition to form a center, enclosing the center in an intermediate layer formed from a first ionomer composition to form a golf ball subassembly, and enclosing the golf ball subassembly in a cover layer formed from a second ionomer composition to form the three-layer golf ball. Examples of ionomer compositions particularly suitable for use in forming the intermediate layer and cover layer include, but are not limited to, those given in Table 8 below.

TABLE 8

	Example 3
<b>Center Composition</b>	
Buna CB 23 (parts)	100
Dicumyl peroxide (parts)	0.5
Zn oxide	2
Zinc Diacrylate	10
Expancel ® 461 DET 40 d25	5
Center Composition Density (g/cm <sup>3</sup> )	0.4
<b>Center Properties</b>	
Diameter (inches)	1.2
Weight (oz)	5.9

TABLE 8-continued

	Example 3
Compression (Atti)	-20
Deflection (130-10 kgf)	6.8
COR	0.749
Center Hardness (Shore C)	16
Surface Hardness (Shore C)	21
<b>Intermediate Layer Composition</b>	
HPF 2000 (parts)	100
Intermediate Layer Composition Density (g/cm <sup>3</sup> )	0.97
<b>Golf Ball Subassembly Properties</b>	
Diameter (inches)	1.735
Weight (oz)	34.69
Compression (Atti)	65
Deflection (130-10 kgf)	3.4
COR	0.8
Surface Hardness (Shore C)	79
<b>Cover Composition</b>	
Surlyn ® 8940 (parts)	50
Surlyn ® 9910 (parts)	25
Surlyn ® AD 1022	25
Color Masterbatch	5
<b>Ball Properties</b>	
Diameter (inches)	1.87
Weight (oz)	45.7
Compression (Atti)	80
Deflection (130-10 kgf)	3
COR	0.805
Surface Hardness (Shore D)	63
MOI (oz · in <sup>2</sup> )	0.626

[0340] Four-layer golf balls of the present invention can be made by molding spheres of a polybutadiene composition to form a center, enclosing the center in a first intermediate layer formed from a first ionomer composition to form a first golf ball subassembly, enclosing the first golf ball subassembly in a second intermediate layer formed from a second ionomer composition to form a second golf ball subassembly, and enclosing the second golf ball subassembly in a cover layer formed from a third ionomer composition to form the four-layer golf ball. Examples of ionomer compositions particularly suitable for use in forming the intermediate layers and cover layer include, but are not limited to, those given in Table 9 below.

TABLE 9

	Ex. 4
<b>Center Composition</b>	
Buna CB 23 (parts)	100
Dicumyl peroxide (parts)	0.6
Zn oxide	2
Zinc Diacrylate	17
Expancel ® 461 DET 40 d25	5
Center Composition Density (g/cm <sup>3</sup> )	0.45
<b>Center Properties</b>	
Diameter (inches)	1.37
Weight (oz)	9.9
Compression (Atti)	20
Deflection (130-10 kgf)	5.3
COR	0.762
Center Hardness (Shore C)	31
Surface Hardness (Shore C)	42



TABLE 9-continued

	Ex. 4
<b>First Intermediate Layer Composition</b>	
HPF 2000 (parts)	100
First Intermediate Layer Composition Density (g/cm <sup>3</sup> )	0.97
<b>First Golf Ball Subassembly Properties</b>	
Diameter (inches)	1.62
Weight (oz)	23.8
Compression (Atti)	70
Deflection (130-10 kgf)	3.2
COR	0.79
Surface Hardness (Shore C)	79
<b>Second Intermediate Layer Composition</b>	
Surlyn ® 8150	50
Surlyn ® 9120	50
Color Masterbatch	5
<b>Second Golf Ball Subassembly Properties</b>	
Diameter (inches)	1.77
Weight (oz)	34.4

TABLE 9-continued

	Ex. 4
<b>Ball Properties</b>	
Diameter (inches)	1.90
Weight (g)	45.7
Compression (Atti)	96
Deflection (130-10 kgf)	2.6
COR	0.815
Surface Hardness (Shore D)	57
MOI (oz · in <sup>2</sup> )	0.65

**[0341]** Advantageously, high CoR, shorter flight distance, buoyant golf balls of the invention can provide a player with valuable constructive off-course feedback which the player may reliably apply during a game on a golf course using a high CoR normal flight distance golf ball to improve performance.

**[0342]** Tables 10A-10D below highlight some of the novel features of golf balls of the invention. Several inventive three layered golf balls Ex. 1, Ex. 2 and Ex. 3 were made and compared with comparative golf balls Comp. Ex. 1 and Comp. Ex. 2 as follows:

TABLE 10A

Golf Ball Layer	Golf Balls Features	Ex. 1	Ex. 2	Ex. 3	Comp. Ex. 1	Comp. Ex. 2
1st Layer	Diam.	1.55	1.55	1.55	1.55	1.55
	Material	50% HNP1000/ 50% AD1035	50% HNP1000 140% AD1035/ 10% 8320	50% HNP100/ 30% AD1035/ 20% 8321	50% HNP1000/ 50% AD1035 + BaSO4	Poly- butadiene Comp.
	SG (g/cc)	0.95	0.95	0.95	1.12	1.13
	DCM	69	62	55	83	85
	Shore C Hardn.	71	68	68	80	83
2nd Layer	Outer Diam.	1.62	1.62	1.62	1.62	1.62
	Material	50% 7940/ 50% 8945	50% 7940/ 50% 8945	50% 7940/ 50% 8945	50% 7940/ 50% 8945	50% 7940/ 50% 8945
	SG(g/cc)	0.95	0.95	0.95	0.95	0.95
	DCM	78	79	81	92	92
	Shore C Hardn. CoR	92	93	94	93	93
3rd Layer	Outer Diam.	1.683	1.683	1.683	1.683	1.683
	Material	6.0% NCO Cast Urethane	6.0% NCO Cast Urethane	6.0% NCO Cast Urethane	6.0% NCO Cast Urethane	6.0% NCO Cast Urethane
	SG(g/cc)	1.13	1.13	1.13	1.13	1.13
	DCM	85	88	90	92	94
	Shore C Hardn.	83	82	82	81	81

TABLE 9-continued

	Ex. 4
<b>Cover Composition</b>	
Compression (Atti)	87
Deflection (130-10 kgf)	2.8
COR	0.82
Surface Hardness (Shore D)	72
<b>Cover Composition</b>	
Surlyn ® 8940 (parts)	45
Surlyn ® 9910 (parts)	15
Surlyn ® AD 1022	40
Color Masterbatch	5

**[0343]** Meanwhile, numerous resulting properties of golf balls Ex. 1, Ex. 2 and Ex. 3 were compared with those of comparative golf balls Comp. Ex. 1 and Comp. Ex. 2 and are recorded in Table 10B below:

TABLE 10B

GOLF BALL PROPERTY	Ex. 1	Ex. 2	Ex. 3	Comp. Ex. 1	Comp. Ex. 2
Weight (oz)	1.375	1.373	1.375	1.611	1.611
SG	0.965	0.965	0.965	1.11	1.11

TABLE 10B-continued

GOLF BALL PROPERTY	Ex. 1	Ex. 2	Ex. 3	Comp. Ex. 1	Comp. Ex. 2
CoR	0.837	0.825	0.816	0.806	0.808
Initial Velocity (IV)	257.7	255.8	254.6	253	253.2
Launch Angle	11.2	11.3	11.2	11.2	11.2
Spin	2699	2644	2709	2685	2699
Speed	172.7	172.3	171.5	166.8	167
Calc. Distance	275 yds	275 yds	273 yds	287 yds	291 yds
Peak Height	42 yds	41 yds	41 yds	38 yds	36 yds

**[0344]** Referring to Tables 10A, and 10B, all five golf balls Ex. 1, Ex. 2, Ex. 3, Comp. Ex. 1 and Comp. Ex. 2 had an overall diameter of 1.683 inches, with each first layer having a diameter of 1.55 inches, each second layer having an outer diameter of 1.62 inches (i.e., thickness of 0.035 inches), and each third layer having an outer diameter of 1.683 (i.e., thickness of 0.032 inches).

**[0345]** Moreover, all five golf balls Ex. 1, Ex. 2, Ex. 3, Comp. Ex. 1 and Comp. Ex. 2 had a second layer having a specific gravity of 0.95 g/cc and consisting of the same Surlyn® ionomer blend of 50% 7940 and 50% 8945. Furthermore, each of golf balls Ex. 1, Ex. 2, Ex. 3, Comp. Ex. 1 and Comp. Ex. 2 had a third layer having a specific gravity of 1.13 g/cc and consisting of the same cast 6.0% NCO urethane.

**[0346]** However, each of the first layers of golf balls Ex. 1, Ex. 2 and Ex. 3, Comp. Ex. 1 and Comp. Ex. 2 had different formulations. Golf balls Ex. 1, Ex. 2 and Ex. 3 and Comp. Ex. 1 consisted of HNP blends, whereas Comp. Ex. 2 consisted of a rubber composition.

**[0347]** Specifically, golf ball Ex. 1 consisted of 50% of an ionomer of ethylene acid acrylate terpolymer (HPF®1000) and 50% of ethylene acid acrylate terpolymer (AD®1035); the first layer of golf ball Ex. 2 consisted of 50% of HPF®1000, 40% of AD® 1035, and 10% of an ionomer of ethylene acid acrylate terpolymer (DuPont™ Surlyn® 8320); the first layer of golf ball Ex. 3 consisted of 50% of HPF®1000, 30% of AD®1035, and 20% Surlyn® 8320; the first layer of golf ball Comp. Ex. 1 consisted of 50% HNP1000, 50% AD1035 plus BaSO<sub>4</sub>; and the first layer of golf ball Comp. Ex. 2 consisted of Buna @CB 1221 (Cobalt Butadiene Rubber commercially available from LANXESS) (85 phr), Buna @CB 23 (neodymium-catalyzed polybutadiene rubber, commercially available from Lanxess Corporation)(15 phr), colorant (0.9 phr), Trigonox® 265-50 BPD (peroxide commercially available from AKZO NOBEL)(1 phr), Core Regrind (15 phr), Rhenogran® Zn-PCTP-70 (zinc pentachlorothiophenol, commercially available from RheinChemie)(0.7 phr), Vulkanox® BKF-75 (antioxidant commercially available from LANXESS)(0.54 phr), Aflux® 16 (processing promoter commercially available from LANXESS (1 phr), Dymalink® 526 (ZDA commercially available from Cray Valley) (32 phr), Polywate® 325 (barium sulfate commercially available from Cimbar) (16.3 phr), Zinc Oxide CR-4 (activator commercially available from Western Reserve Chemical)(5 phr).

**[0348]** Each of the first layers of golf balls Ex. 1, Ex. 2 and Ex. 3 had specific gravities of 0.95 g/cc, whereas the first

layer of golf ball Comp. Ex. 1 had a specific gravity of 1.12 g/cc, and the first layer of golf ball Comp. Ex. 2 had a specific gravity of 1.13 g/cc.

**[0349]** The first layers of golf balls Ex. 1, Ex. 2 and Ex. 3 had DCM compressions that were at least 14 and 16 compression points less than the first layers of golf balls Comp. Ex. 1 and Comp. Ex. 2. Meanwhile, the second layers of golf balls Ex. 1, Ex. 2 and Ex. 3 had DCM compressions that were at least 11 compression points less than the second layers of golf balls Comp. Ex. 1 and Comp. Ex. 2. And the third layers of golf balls Ex. 1, Ex. 2 and Ex. 3 had DCM compressions that were within two and four DCM compression points of the third layer of Comp. Ex. 1 and Comp. Ex. 2.

**[0350]** The first layers of golf balls Ex. 1, Ex. 2, and Ex. 3 had Shore C hardnesses that were at least 12 and 15 Shore C hardness points less than the Shore C hardnesses of the first layers of golf balls Comp. Ex. 1 and Comp. Ex. 2. Meanwhile, the second layers of golf balls Ex. 1, Ex. 2, and Ex. 3 had Shore C hardnesses that were within 1 Shore C hardness point of the Shore C hardness of each of the second layers of golf balls Comp. Ex. 1 and Comp. Ex. 2. And the third layers of golf balls Ex. 1, Ex. 2, and Ex. 3 had Shore C hardnesses that were up to two Shore C hardness points greater than the Shore C hardnesses of the third layers golf balls Comp. Ex. 1 and Comp. Ex. 2.

**[0351]** Notably, golf balls Ex. 1, Ex. 2 and Ex. 3 had overall specific gravities of less than 1.0 g/cc and therefore float in water, whereas both of golf balls Comp. Ex. 1 and Comp. Ex. 2 had overall specific gravities greater than 1.0, and therefore would not float in water. Specifically, golf balls Ex. 1 and Ex. 2 had overall specific gravities of 0.950; golf ball Ex. 3 had an overall specific gravity of 0.948; whereas golf balls Comp. Ex. 1 and Comp. Ex. 2 each had overall specific gravities of 1.11.

**[0352]** Furthermore, all three inventive finished golf balls Ex. 1, Ex. 2, and Ex. 3 had a high CoR of 0.837, 0.825, and 0.816, respectively, whereas golf balls Comp. Ex. 1 and Comp. Ex. 2 had CoRs less than 0.810, namely 0.806 and 0.808—even though all of golf balls Ex. 1, Ex. 2, Ex. 3, Comp. Ex. 1 and Comp. Ex. 2 contained a subassembly (second layer L<sub>2</sub> surrounding the first layer L<sub>1</sub>) having a CoR of at least 0.810 (namely 0.842, 0.83, 0.822, 0.813 and 0.815, respectively).

**[0353]** Additionally, as shown in Table 10B, golf balls Ex. 1, Ex. 2 and Ex. 3 have desirably shorter flight distances of 275, 275 and 273 yards, respectively—at least 12 and 16 yards less than that of golf balls Comp. Ex. 1 (287) and Comp. Ex. 2 (291 yards) when hit at similar launch angles, producing greater spin, and reaching peak heights greater than that of golf balls Comp. Ex. 1 and Comp. Ex. 2.

**[0354]** Accordingly, golf balls Ex. 1, Ex. 2 and Ex. 3 have high golf ball CoRs of at least 0.810 and initial velocities of at least 250 ft/s, and achieve a much lower/shorter flight distance than comparative golf balls Comp. Ex. 1 and Comp. Ex. 2 and can meanwhile float in water bodies on practice ranges, while producing greater spin, and producing peak flight heights at or above that of comparative golf balls Comp. Ex. 1 and Comp. Ex. 2.

**[0355]** Golf balls of the invention are also envisioned having greater than three layers. In this regard, Table 10C below includes additional possible three and four piece inventive golf ball constructions as follows:

TABLE 10C

Layer	Golf Ball Features	Ex. 4	Ex. 5	Ex. 6	Ex. 7
First Layer	Construction	3 pc	4 pc	4 pc	4 pc
	Formulation	C	A	D	E
	Size	1.53"	1.40"	1.42"	1.25
	Material	HPF	x-linked polybutadiene +microspheres	HPF Blend	HPF blend +microspheres
	SG	0.95	0.98	0.95	0.88
	Weight	29.2 g/1.03 oz	23.1 g/.81 oz	23.3 g/0.82 oz	15.1 g/0.53 oz
	Shore C	65	60	68	70
	DCM	35	42	50	65
	COR	0.79	0.786	0.805	0.799
	IV	253	252	254.5	253
	Second Layer	Formulation	—	F	F
Size		—	1.575"	1.51"	1.56"
Material		—	HPF	HPF	x-linked polybutadiene microspheres
SG		—	0.95	0.95	1.04
Weight		—	32.5 g/1.14 oz	28.1 g/0.99 oz	31.1 g/1.09 oz
Shore C		—	77	77	82
Shore D		—	44	48	52
DCM		—	56	63	77
COR		—	0.808	0.82	0.812
IV		—	254.5	256	254.5
Third Layer		Formulation	G	G	G
	Size	1.68"	1.70"	1.60"	1.66"
	Material	High Acid Surlyn blend	High Acid Surlyn blend	High Acid Surlyn blend	High Acid Surlyn blend
	SG	0.95	0.95	0.95	0.95
	Weight	38.7 g/1.36 oz	41.4 g/1.46 oz	33.4/1.18 oz	37.5 g/1.32 oz
	Shore C	98	98	98	99
	Shore D	70	71	71	72
	DCM	68	85	89	96
	COR	0.829	0.834	0.835	0.835
	IV	257	257.2	257.2	257
	Fourth Layer	Formulation	I	I	H
Size		1.720"	1.75"	1.69"	1.70"
Material		Cast Urethane	Cast Urethane	Hard/Soft Ionomer	Cast Urethane
SG		1.13	1.13	0.97	1.13
Weight		41.4 g/1.46 oz	44.2 g/1.56	38.9 g/1.37 oz	40.2 g/1.42 oz
Shore C		83	84	94	85
DCM		73	90	96	102
COR		0.822	0.829	0.844	0.83
IV		256	256.5	258.3	256
Ball SG		0.96	0.97	0.95	0.96

[0356] Layer formulations A through F, identified in Table 10C with respect to golf balls Ex. 4, Ex. 5, Ex. 6 and Ex. 7, are set forth in Table 10D as follows:

TABLE 10D

GOLF BALL LAYER MATERIAL FORMULATIONS									
INGREDIENTS	A	B	C	D	E	F	G	H	I
Polybutadiene	100	10	—	—	—	—	—	—	—
Zinc Diacrylate	21	27	—	—	—	—	—	—	—
Zinc Oxide	5	9	—	—	—	—	—	—	—
Peroxide	0.8	0.8	—	—	—	—	—	—	—
Zinc PCTP	0.5	5	—	—	—	—	—	—	—
3M Glass bubbles IM30K	10	5	—	—	15	—	—	—	—
HPF AD @1035	—	—	—	50	80	—	—	—	—
HPF AD @1172	—	—	100	50	20	—	—	—	—
HPF @2000	—	—	—	—	—	100	—	—	—
Surlyn @8150	—	—	—	—	—	—	50	40	—
Surlyn @9120	—	—	—	—	—	—	50	40	—
Surlyn HPC AD @1022	—	—	—	—	—	—	—	20	—

TABLE 10D-continued

GOLF BALL LAYER MATERIAL FORMULATIONS									
INGREDIENTS	A	B	C	D	E	F	G	H	I
White MB	—	—	—	—	—	—	—	—	5
6.0% NCO	—	—	—	—	—	—	—	—	100
Cast Urethane	—	—	—	—	—	—	—	—	—

[0357] Referring to Table 10C, inventive golf ball Ex. 4 has three layers, and inventive golf balls Ex. 5, Ex. 6 and Ex. 7 have four layers.

[0358] Each of golf balls Ex. 4, Ex. 5, Ex. 6 and Ex. 7 has a high golf ball CoR of at least 0.810, namely 0.822, 0.829, 0.844, and 0.83, respectively.

[0359] Additionally, each of golf balls Ex. 4, Ex. 5, Ex. 6, and Ex. 7 has an overall specific gravity of less than 1.0 g/cc, namely 0.96 g/cc, 0.97 g/cc, 0.95 g/cc and 0.96 g/cc, respectively (based on their respective golf ball weights of

32.5 g/1.14 oz, 28.1 g/0.99 oz, and 31.1 g/1.09 oz, and respective diameters of 1.72 inches, 1.75 inches, 1.69 inches, and 1.70 inches).

**[0360]** Moreover, each of golf balls Ex. 4, Ex. 5, Ex. 6, and Ex. 7 has an initial velocity of at least 250 ft/s, namely 256 ft/s, 256.5 ft/s, 258.3 ft/s, and 256 ft/s, respectively.

**[0361]** In golf ball Ex. 4, the first layer has a diameter of 1.53 inches, the second layer has an outer diameter of 1.68 inches, and the third layer has an outer diameter of 1.720 inches. Thus, the second layer has a thickness of 0.075 inches, and the third layer has a thickness of 0.02 inches. In this golf ball construction, the second layer thickness is greater than the third layer thickness by 0.055 inches.

**[0362]** In golf ball Ex. 5, the first layer has a diameter of 1.40 inches, the second layer has an outer diameter of 1.575 inches, the third layer has an outer diameter of 1.70 inches, and the fourth layer has an outer diameter of 1.75 inches. Thus, the second layer has a thickness of 0.0875 inches, the third layer has a thickness of 0.0625 inches, and the fourth layer has a thickness of 0.025 inches. In this golf ball construction, the second layer thickness is greater than the third layer thickness by 0.0250 inches, which in turn is greater than the fourth layer thickness by 0.0375 inches.

**[0363]** In golf ball Ex. 6, the first layer has a diameter of 1.42 inches, the second layer has an outer diameter of 1.51 inches, the third layer has an outer diameter of 1.60 inches, and the fourth layer has an outer diameter of 1.68 inches. Thus, each of the second layer and third layers have thicknesses of 0.045 inches, while the fourth layer has a thickness of 0.04 inches. In this golf ball construction, the second and third layers have the same thickness, while the fourth layer is thinner by 0.005 inches.

**[0364]** In golf ball Ex. 7, the first layer has a diameter of 1.25 inches, the second layer has an outer diameter of 1.56 inches, the third layer has an outer diameter of 1.66 inches, and the fourth layer has an outer diameter of 1.70 inches. Thus, the second layer has a thickness of 0.155 inches, the third layer has a thickness of 0.05 inches, and the fourth layer has a thickness of 0.02 inches. In this golf ball construction, the second layer thickness is greater than the third layer thickness by 0.105 inches, while the third layer thickness is greater than the fourth layer thickness by 0.03 inches.

**[0365]** The first, second and third layers of golf ball Ex. 4 have specific gravities of 0.95 g/cc, 0.95 g/cc, and 1.13 g/cc, respectively. Meanwhile, the first, second, third, and fourth layers of golf ball Ex. 5 have specific gravities of 0.98 g/cc, 0.95 g/cc, 0.95 g/cc, and 1.13 g/cc, respectively. In turn, the first, second, third and fourth layers of golf ball Ex. 6 have specific gravities of 0.95 g/cc, 0.95 g/cc, 0.95 g/cc, and 0.97 g/cc, respectively. Finally, the first, second third and fourth layers golf ball Ex. 7 have specific gravities of 0.88 g/cc, 1.04 g/cc, 0.95 g/cc, and 1.13 g/cc, respectively. Thus, in each of golf balls Ex. 4, Ex. 5, Ex. 6, and Ex. 7, at least two layers have specific gravities less than 1.13 g/cc. In fact, in golf ball Ex. 4, two of the three layers have specific gravities less than 1.13 g/cc; in golf ball Ex. 5, three of the four layers have specific gravities less than 1.13 g/cc; in golf ball Ex. 6, all four layers have specific gravities less than 1.13 g/cc; and in golf ball Ex. 7, three of the four layers have specific gravities less than 1.13 g/cc.

**[0366]** Golf balls Ex. 4, Ex. 5, Ex. 6, and Ex. 7 have ball Shore C hardnesses of 83, 84, 94 and 85, respectively. Meanwhile, the first and second layers of golf ball Ex. 4

have Shore C hardnesses of 65 and 98, respectively. Additionally, the first, second and third layers of golf ball Ex. 5 have Shore C hardnesses of 60, 77 and 98, respectively. Moreover, the first, second and third layers of golf ball Ex. 6 have Shore C hardnesses of 68, 77 and 98, respectively. Finally, the first, second and third layers of golf ball Ex. 7 have Shore C hardnesses of 70, 82 and 99, respectively.

**[0367]** Golf balls Ex. 4, Ex. 5, Ex. 6, and Ex. 7 have DCM ball compressions of 73, 90, 96, and 102, respectively. Meanwhile, the first and second layers of golf ball Ex. 4 have DCM compressions of 35 and 68, respectively. Additionally, the first, second and third layers of golf ball Ex. 5 have DCM compressions of 42, 56 and 85, respectively. Moreover, the first, second and third layers of golf ball Ex. 6 have DCM compressions of 50, 63 and 89, respectively. Finally, the first, second and third layers of golf ball Ex. 7 have DCM compressions of 65, 77 and 96, respectively.

**[0368]** Accordingly, golf balls of the invention have a high CoR of at least 0.810 yet can achieve a shorter flight distance with the perceived flight trajectory look of a normal/regular flight distance high CoR golf ball, and therefore able to provide the high CoR golf ball user with valuable feedback when taking practice shots in limited spaces. A golf ball of the invention is meanwhile easily retrievable when hit into water bodies on such practice spaces since golf balls of the invention can float.

**[0369]** The following alternative constructions are also envisioned for golf balls of the invention, wherein the resulting golf ball has a CoR of at least 0.810, a golf ball specific gravity  $SG_B$  of less than 1.0 g/cc, an initial velocity of at least 250 ft/s, and yet achieves a shorter flight distance with the perceived flight trajectory look of a normal/regular distance such high CoR golf ball. In one embodiment, the first layer may be a spherical shell layer having an outer surface, an inner surface, and an inner diameter to define a hollow center. In one embodiment, the shell layer is formed from a thermosetting rubber composition. In another embodiment, the shell layer may be formed from an ionomer composition.

**[0370]** The shell layer may have an outer surface, an inner surface, and an inner diameter to define a hollow center. An outer core layer may be disposed about the shell layer, and optionally an intermediate layer disposed between the shell layer and the outer core layer. At least one of these layers may be formed from a highly neutralized polymer composition comprising an acid copolymer of ethylene and an  $\alpha,\beta$ -unsaturated carboxylic acid, optionally including a softening monomer selected from the group consisting of alkyl acrylates and methacrylates; an organic acid or salt thereof; a cation source present in an amount sufficient to neutralize greater than 80% of all acid groups present in the composition; and optionally a non-acid polymer selected from the group consisting of polyolefins, polyamides, polyesters, polyethers, polyurethanes, metallocene-catalyzed polymers, single-site catalyst polymerized polymers, ethylene propylene rubber, ethylene propylene diene rubber, styrenic block copolymer rubbers, alkyl acrylate rubbers, and functionalized derivatives thereof.

**[0371]** In a particular embodiment, the shell layer may be formed from a thermoset rubber composition, with the outer core layer being formed from a first thermoplastic composition, and the optional intermediate core layer, if present, being formed from a second thermoplastic composition. At least one of the first thermoplastic composition and the

second thermoplastic composition may be the highly neutralized acid polymer composition comprising the acid polymer, non-acid polymer, organic acid or salt thereof, and cation source. The difference in Shore C surface hardness between the outer surface of the shell layer and the inner surface of the shell layer may be from 3 Shore C to 25 Shore C.

[0372] In other embodiments, the shell layer may be formed from a first thermoset rubber composition, the outer core layer may be formed from a thermoplastic composition, and the optional intermediate core layer, if present, may be formed from a second thermoset composition. The outer core layer composition may be the highly neutralized acid polymer composition comprising the acid polymer, organic acid or salt thereof, cation source, and optional non-acid polymer. The difference in Shore C surface hardness between the outer surface of the shell layer and the inner surface of the shell layer may be from 3 Shore C to 25 Shore C.

[0373] In yet another embodiment, the shell layer may be formed from a thermoplastic composition, the outer core layer being formed from a first thermoset composition, and the optional intermediate core layer, if present, being formed from a second thermoset composition. The shell layer composition may be the highly neutralized acid polymer composition comprising the acid polymer, organic acid or salt thereof, cation source, and optional non-acid polymer. The difference in Shore C surface hardness between the outer surface of the shell layer and the inner surface of the shell layer may be from 0 Shore C to 5 Shore C.

[0374] In still another embodiment, the shell layer may be formed from a first thermoplastic composition, the outer core layer being formed from a thermoset composition, and the optional intermediate core layer, if present, being formed from a second thermoplastic composition. At least one of the first thermoplastic composition and the second thermoplastic composition may be the highly neutralized acid polymer composition comprising the acid polymer, organic acid or salt thereof, cation source, and optional non-acid polymer. The difference in Shore C surface hardness between the outer surface of the shell layer and the inner surface of the shell layer may be from 0 Shore C to 5 Shore C.

[0375] In an alternative embodiment, the shell layer may be formed from a first thermoplastic composition, the outer core layer being formed from a second thermoplastic composition, and the optional intermediate core layer, if present, being formed from a third thermoplastic composition. At least one of the first thermoplastic composition, the second thermoplastic composition, and the third thermoplastic composition may be the highly neutralized acid polymer composition comprising the acid polymer, organic acid or salt thereof, cation source, and optional non-acid polymer. The difference in Shore C surface hardness between the outer surface of the shell layer and the inner surface of the shell layer may be from 0 Shore C to 5 Shore C.

[0376] In another alternative embodiment, the shell layer may be formed from a first thermoplastic composition, the outer core layer being formed from a second thermoplastic composition, and the optional intermediate core layer, if present, being formed from a thermoset composition. At least one of the first thermoplastic composition and the second thermoplastic composition may be the highly neutralized acid polymer composition comprising the acid polymer, organic acid or salt thereof, cation source, and optional

non-acid polymer. The difference in Shore C surface hardness between the outer surface of the shell layer and the inner surface of the shell layer may be from 0 Shore C to 5 Shore C.

[0377] In yet another alternative embodiment, the shell layer may be formed from a first thermoset rubber composition, the outer core layer being formed from a second thermoset composition, and at least one intermediate core layer being formed from a thermoplastic composition being disposed between the shell layer and the outer core layer. The intermediate core layer composition may be the highly neutralized acid polymer composition comprising the acid polymer, organic acid or salt thereof, cation source, and optional non-acid polymer. The difference in Shore C surface hardness between the outer surface of the shell layer and the inner surface of the shell layer may be from 10 Shore C to 25 Shore C.

[0378] In one embodiment, the golf ball has a diameter of 1.70 inches or greater and the inner core layer has a diameter of 1.60 inches or greater and may be formed from a foamed polyurethane composition. A cover layer may be formed from a composition comprising an acid copolymer of ethylene and an  $\alpha,\beta$ -unsaturated carboxylic acid, optionally including a softening monomer selected from the group consisting of alkyl acrylates and methacrylates; an organic acid or salt thereof; a cation source present in an amount sufficient to neutralize greater than 80% of all acid groups present in the composition; and optionally a non-acid polymer selected from the group consisting of polyolefins, polyamides, polyesters, polyethers, polyurethanes, metallo-cene-catalyzed polymers, single-site catalyst polymerized polymers, ethylene propylene rubber, ethylene propylene diene rubber, styrenic block copolymer rubbers, alkyl acrylate rubbers, and functionalized derivatives thereof. In a particular aspect of this embodiment, the inner core layer has an outer surface hardness ( $H_{\text{inner core surface}}$ ) and a center hardness ( $H_{\text{inner core center}}$ ), the  $H_{\text{inner core surface}}$  being greater than the  $H_{\text{inner core center}}$  to provide a positive hardness gradient. In another particular aspect of this embodiment, the inner core layer has an outer surface hardness ( $H_{\text{inner core surface}}$ ) and a center hardness ( $H_{\text{inner core center}}$ ), the  $H_{\text{inner core surface}}$  being the same or less than the  $H_{\text{inner core center}}$  to provide a zero or negative hardness gradient.

[0379] In another embodiment, the golf ball has a diameter of greater than 1.70 inches and comprises an inner core layer, an outer core layer, and a cover layer. The inner core layer has a diameter of 1.30 or greater and may be formed from a foamed polyurethane composition. The outer core layer has a thickness of 0.20 inches or greater and formed from a thermoset composition.

[0380] In a particular aspect of this embodiment, the inner core layer has an outer surface hardness ( $H_{\text{inner core surface}}$ ) and a center hardness ( $H_{\text{inner core center}}$ ), the  $H_{\text{inner core surface}}$  being greater than the  $H_{\text{inner core center}}$  to provide a positive hardness gradient; and the outer core layer has an outer surface hardness ( $H_{\text{outer surface of OC}}$ ) and an inner surface hardness ( $H_{\text{inner surface of OC}}$ ), the  $H_{\text{outer surface of OC}}$  being greater than the  $H_{\text{inner surface of OC}}$  to provide a positive hardness gradient.

[0381] In another particular aspect of this embodiment, the inner core layer has an outer surface hardness ( $H_{\text{inner core surface}}$ ) and a center hardness ( $H_{\text{inner core center}}$ ), the  $H_{\text{inner core surface}}$  being greater than the  $H_{\text{inner core center}}$  to provide a positive hardness gradient; and the outer core layer has an

outer surface hardness ( $H_{\text{outer surface of OC}}$ ) and an inner surface hardness ( $H_{\text{inner surface of OC}}$ ), the  $H_{\text{outer surface of OC}}$  being the same or less than the  $H_{\text{inner surface of OC}}$  to provide a zero or negative hardness gradient.

[0382] In another particular aspect of this embodiment, the inner core layer has an outer surface hardness ( $H_{\text{inner core surface}}$ ) and a center hardness ( $H_{\text{inner core center}}$ ), the  $H_{\text{inner core surface}}$  being the same or less than the  $H_{\text{inner core center}}$  to provide a zero or negative hardness gradient; and the outer core layer has an outer surface hardness ( $H_{\text{outer surface of OC}}$ ) and an inner surface hardness ( $H_{\text{inner surface of OC}}$ ), the  $H_{\text{outer surface of OC}}$  being greater than the  $H_{\text{inner surface of OC}}$  to provide a positive hardness gradient.

[0383] In another particular aspect of this embodiment, the inner core layer has an outer surface hardness ( $H_{\text{inner core surface}}$ ) and a center hardness ( $H_{\text{inner core center}}$ ), the  $H_{\text{inner core surface}}$  being the same or less than the  $H_{\text{inner core center}}$  to provide a zero or negative hardness gradient; and the outer core layer has an outer surface hardness ( $H_{\text{outer surface of OC}}$ ) and an inner surface hardness ( $H_{\text{inner surface of OC}}$ ), the  $H_{\text{outer surface of OC}}$  being the same or less than the  $H_{\text{inner surface of OC}}$  to provide a zero or negative hardness gradient.

[0384] In another embodiment, the core assembly for the golf ball comprises a foamed inner core layer and an outer core layer. The inner core layer has a diameter of from 0.100 inches to 1.100 inches. The outer core layer has a thickness of from 0.100 inches to 0.750 inches. The specific gravity of the outer core layer may be greater than the specific gravity of the inner core layer.

[0385] In a particular aspect of this embodiment, the inner core layer has a positive hardness gradient, the outer core layer may be formed from a thermoplastic composition and has a positive hardness gradient, and at least one of the inner core layer composition and the outer core layer composition may be a highly neutralized polymer composition comprising an acid copolymer of ethylene and an  $\alpha,\beta$ -unsaturated carboxylic acid, optionally including a softening monomer selected from the group consisting of alkyl acrylates and methacrylates; an organic acid or salt thereof; a cation source present in an amount sufficient to neutralize greater than 80% of all acid groups present in the composition; and optionally a non-acid polymer selected from the group consisting of polyolefins, polyamides, polyesters, polyethers, polyurethanes, metallocene-catalyzed polymers, single-site catalyst polymerized polymers, ethylene propylene rubber, ethylene propylene diene rubber, styrenic block copolymer rubbers, alkyl acrylate rubbers, and functionalized derivatives thereof.

[0386] In another particular aspect of this embodiment, the inner core layer has a positive hardness gradient, the outer core layer may be formed from a thermoplastic composition and has a zero or negative hardness gradient, and at least one of the inner core layer composition and the outer core layer composition is a highly neutralized polymer composition comprising an acid copolymer of ethylene and an  $\alpha,\beta$ -unsaturated carboxylic acid, optionally including a softening monomer selected from the group consisting of alkyl acrylates and methacrylates; an organic acid or salt thereof; a cation source present in an amount sufficient to neutralize greater than 80% of all acid groups present in the composition; and optionally a non-acid polymer selected from the group consisting of polyolefins, polyamides, polyesters, polyethers, polyurethanes, metallocene-catalyzed polymers, single-site catalyst polymerized polymers, ethylene propyl-

ene rubber, ethylene propylene diene rubber, styrenic block copolymer rubbers, alkyl acrylate rubbers, and functionalized derivatives thereof.

[0387] In another particular aspect of this embodiment, the inner core layer has a zero or negative hardness gradient, the outer core layer may be formed from a thermoplastic composition and has a positive hardness gradient, and at least one of the inner core layer composition and the outer core layer composition is a highly neutralized polymer composition comprising an acid copolymer of ethylene and an  $\alpha,\beta$ -unsaturated carboxylic acid, optionally including a softening monomer selected from the group consisting of alkyl acrylates and methacrylates; an organic acid or salt thereof; a cation source present in an amount sufficient to neutralize greater than 80% of all acid groups present in the composition; and optionally a non-acid polymer selected from the group consisting of polyolefins, polyamides, polyesters, polyethers, polyurethanes, metallocene-catalyzed polymers, single-site catalyst polymerized polymers, ethylene propylene rubber, ethylene propylene diene rubber, styrenic block copolymer rubbers, alkyl acrylate rubbers, and functionalized derivatives thereof.

[0388] In another particular aspect of this embodiment, the inner core layer has a zero or negative hardness gradient, the outer core layer may be formed from a thermoplastic composition and has a zero or negative hardness gradient, and at least one of the inner core layer composition and the outer core layer composition is a highly neutralized polymer composition comprising an acid copolymer of ethylene and an  $\alpha,\beta$ -unsaturated carboxylic acid, optionally including a softening monomer selected from the group consisting of alkyl acrylates and methacrylates; an organic acid or salt thereof; a cation source present in an amount sufficient to neutralize greater than 80% of all acid groups present in the composition; and optionally a non-acid polymer selected from the group consisting of polyolefins, polyamides, polyesters, polyethers, polyurethanes, metallocene-catalyzed polymers, single-site catalyst polymerized polymers, ethylene propylene rubber, ethylene propylene diene rubber, styrenic block copolymer rubbers, alkyl acrylate rubbers, and functionalized derivatives thereof.

[0389] In another particular aspect of this embodiment, the inner core layer may be formed from a foamed polyurethane composition comprising mineral filler particulate in an amount of from 0.1 wt % to 9.0 wt %, based on the total weight of the foamed polyurethane composition, and the outer core layer may be formed from a non-foamed highly neutralized polymer composition comprising an acid copolymer of ethylene and an  $\alpha,\beta$ -unsaturated carboxylic acid, optionally including a softening monomer selected from the group consisting of alkyl acrylates and methacrylates; an organic acid or salt thereof; a cation source present in an amount sufficient to neutralize greater than 80% of all acid groups present in the composition; and optionally a non-acid polymer selected from the group consisting of polyolefins, polyamides, polyesters, polyethers, polyurethanes, metallocene-catalyzed polymers, single-site catalyst polymerized polymers, ethylene propylene rubber, ethylene propylene diene rubber, styrenic block copolymer rubbers, alkyl acrylate rubbers, and functionalized derivatives thereof.

[0390] In another particular aspect of this embodiment, the outer core layer has a positive hardness gradient and may be formed from a thermoset composition, and the inner core layer has a positive hardness gradient and may be formed

from a highly neutralized polymer composition comprising an acid copolymer of ethylene and an  $\alpha,\beta$ -unsaturated carboxylic acid, optionally including a softening monomer selected from the group consisting of alkyl acrylates and methacrylates; an organic acid or salt thereof; a cation source present in an amount sufficient to neutralize greater than 80% of all acid groups present in the composition; and optionally a non-acid polymer selected from the group consisting of polyolefins, polyamides, polyesters, polyethers, polyurethanes, metallocene-catalyzed polymers, single-site catalyst polymerized polymers, ethylene propylene rubber, ethylene propylene diene rubber, styrenic block copolymer rubbers, alkyl acrylate rubbers, and functionalized derivatives thereof.

**[0391]** In another particular aspect of this embodiment, the outer core layer has a zero or negative hardness gradient and may be formed from a thermoset composition, and the inner core layer has a positive hardness gradient and is formed from a highly neutralized polymer composition comprising an acid copolymer of ethylene and an  $\alpha,\beta$ -unsaturated carboxylic acid, optionally including a softening monomer selected from the group consisting of alkyl acrylates and methacrylates; an organic acid or salt thereof; a cation source present in an amount sufficient to neutralize greater than 80% of all acid groups present in the composition; and optionally a non-acid polymer selected from the group consisting of polyolefins, polyamides, polyesters, polyethers, polyurethanes, metallocene-catalyzed polymers, single-site catalyst polymerized polymers, ethylene propylene rubber, ethylene propylene diene rubber, styrenic block copolymer rubbers, alkyl acrylate rubbers, and functionalized derivatives thereof.

**[0392]** In another particular aspect of this embodiment, the outer core layer has a positive hardness gradient and may be formed from a thermoset composition, and the inner core layer has a zero or negative hardness gradient and is formed from a highly neutralized polymer composition comprising an acid copolymer of ethylene and an  $\alpha,\beta$ -unsaturated carboxylic acid, optionally including a softening monomer selected from the group consisting of alkyl acrylates and methacrylates; an organic acid or salt thereof; a cation source present in an amount sufficient to neutralize greater than 80% of all acid groups present in the composition; and optionally a non-acid polymer selected from the group consisting of polyolefins, polyamides, polyesters, polyethers, polyurethanes, metallocene-catalyzed polymers, single-site catalyst polymerized polymers, ethylene propylene rubber, ethylene propylene diene rubber, styrenic block copolymer rubbers, alkyl acrylate rubbers, and functionalized derivatives thereof.

**[0393]** In another particular aspect of this embodiment, the outer core layer has a zero or negative hardness gradient and may be formed from a thermoset composition, and the inner core layer has a zero or negative hardness gradient and may be formed from a highly neutralized polymer composition comprising an acid copolymer of ethylene and an  $\alpha,\beta$ -unsaturated carboxylic acid, optionally including a softening monomer selected from the group consisting of alkyl acrylates and methacrylates; an organic acid or salt thereof; a cation source present in an amount sufficient to neutralize greater than 80% of all acid groups present in the composition; and optionally a non-acid polymer selected from the group consisting of polyolefins, polyamides, polyesters, polyethers, polyurethanes, metallocene-catalyzed polymers,

single-site catalyst polymerized polymers, ethylene propylene rubber, ethylene propylene diene rubber, styrenic block copolymer rubbers, alkyl acrylate rubbers, and functionalized derivatives thereof.

**[0394]** In the above embodiments, the highly neutralized composition comprising an acid copolymer, a non-acid polymer, an organic acid or salt thereof, and a cation source optionally has one or more of the following properties:

**[0395]** (a) the acid copolymer does not include a softening monomer;

**[0396]** (b) the acid of the acid copolymer is selected from acrylic acid and methacrylic acid;

**[0397]** (c) the acid of the acid copolymer is present in the acid copolymer in an amount of from 15 mol % to 30 mol %, based on the total weight of the acid copolymer;

**[0398]** (d) the non-acid polymer is an alkyl acrylate rubber selected from ethylene-alkyl acrylates and ethylene-alkyl methacrylates;

**[0399]** (e) the non-acid polymer is present in an amount of greater than 50 wt %, based on the combined weight of the acid copolymer and the non-acid polymer;

**[0400]** (f) the non-acid polymer is present in an amount of 20 wt % or greater, based on the total weight of the highly neutralized composition;

**[0401]** (g) the non-acid polymer is present in an amount of less than 50 wt %, based on the combined weight of the acid copolymer and the non-acid polymer;

**[0402]** (h) the highly neutralized polymer composition has a solid sphere compression of 40 or less and a coefficient of restitution of 0.820 or greater;

**[0403]** (i) the highly neutralized polymer composition has a solid sphere compression of 100 or greater and a coefficient of restitution of 0.860 or greater;

**[0404]** (j) the organic acid salt is a metal salt of oleic acid;

**[0405]** (k) the organic salt is magnesium oleate;

**[0406]** (l) the organic salt is present in an amount of 30 parts or greater, per 100 parts of acid copolymer and non-acid copolymer combined; and

**[0407]** (m) the cation source is present in an amount sufficient to neutralize 110% or greater of all acid groups present in the composition.

What is claimed is:

1. A golf ball having an outer surface with a plurality of dimples disposed thereon, wherein the golf ball has:
  - a coefficient of restitution (CoR) of at least 0.810,
  - a specific gravity of less than 1.00 g/cc,
  - an initial velocity of at least 250 ft/s,
  - a first aerodynamic coefficient magnitude between about 0.25 and about 0.30 and a first aerodynamic force angle between about 29 degrees and 34 degrees at a Reynolds Number of 230000 and a spin ratio of 0.085, and
  - wherein the golf ball comprises three layers  $L_1$ ,  $L_2$ , and  $L_3$ ;
    - wherein layer  $L_1$  is formed of at least one rubber and has a first specific gravity  $SG_1$ ;
    - wherein layer  $L_2$  surrounds  $L_1$  and is formed of at least one highly neutralized polymer and has a second specific gravity  $SG_2$ ; and
    - wherein layer  $L_3$  surrounds  $L_2$  and has a third specific gravity  $SG_3$ ;
    - wherein at least two of  $SG_1$ ,  $SG_2$ , and  $SG_3$  are less than 1.13 g/cc.

2. The golf ball of claim 1, wherein:  
the first aerodynamic force angle,  $\theta_{F1}$ , satisfies the condition

$$95.4SG_B^2 - 156.4SG_B + 95 \geq \theta_{F1} \geq 95.4SG_B^2 - 156.4SG_B + 90,$$

wherein  $SG_B$  is the specific gravity of the golf ball in g/cc.

3. The golf ball of claim 1, wherein a second aerodynamic coefficient magnitude between about 0.26 and about 0.31 and a second aerodynamic force angle between about 31 degrees and 36 degrees at a Reynolds Number of 180000 and a spin ratio of 0.101.

4. The golf ball of claim 3, wherein:

the second aerodynamic force angle,  $\theta_{F2}$ , satisfies the condition

$$95.4SG_B^2 - 156.4SG_B + 97 \geq \theta_{F2} \geq 95.4SG_B^2 - 156.4SG_B + 92,$$

wherein  $SG_B$  is the specific gravity of the golf ball in g/cc.

5. The golf ball of claim 1, wherein the layer  $L_3$  is formed from at least one of a thermoset or thermoplastic composition.

6. The golf ball of claim 5, wherein the thermoset or thermoplastic composition comprises one or more of a polyurethane, polyurea, polyurethane/polyurea hybrids, or ionomer.

7. The golf ball of claim 6, wherein the thermoset or thermoplastic composition comprises a partially neutralized polymer.

8. The golf ball of claim 6, wherein the thermoset or thermoplastic composition comprises a highly neutralized polymer.

9. A golf ball having an outer surface with a plurality of dimples disposed thereon, wherein the golf ball has:

a coefficient of restitution (CoR) of at least 0.810,

a specific gravity of less than 1.00 g/cc,

an initial velocity of at least 250 ft/s,

a first aerodynamic coefficient magnitude between about 0.25 and about 0.30 and a first aerodynamic force angle between about 29 degrees and 34 degrees at a Reynolds Number of 230000 and a spin ratio of 0.085,

a second aerodynamic coefficient magnitude between about 0.26 and about 0.31 and a second aerodynamic force angle between about 31 degrees and 36 degrees at a Reynolds Number of 180000 and a spin ratio of 0.101,

a third aerodynamic coefficient magnitude between about 0.27 and about 0.32 and a third aerodynamic force angle between about 34 degrees and 39 degrees at a Reynolds Number of 133000 and a spin ratio of 0.133; and

a fourth aerodynamic coefficient magnitude between about 0.33 and about 0.38 and a fourth aerodynamic force angle between about 38 degrees and 43 degrees at a Reynolds Number of 89000 and a spin ratio of 0.183, wherein the golf ball consists of three layers  $L_1$ ,  $L_2$ , and  $L_3$ ;

wherein layer  $L_1$  is formed of at least one rubber and has a first specific gravity  $SG_1$ ;

wherein layer  $L_2$  surrounds  $L_1$  and is formed of at least one highly neutralized polymer and has a second specific gravity  $SG_2$ ; and

wherein layer  $L_3$  surrounds  $L_2$  and has a third specific gravity  $SG_3$ ;

wherein at least two of  $SG_1$ ,  $SG_2$ , and  $SG_3$  are less than 1.13 g/cc.

10. The golf ball of claim 9, wherein:

the third aerodynamic force angle,  $\theta_{F3}$ , satisfies the condition

$$95.4SG_B^2 - 156.4SG_B + 100 \geq \theta_{F3} \geq 95.4SG_B^2 - 156.4SG_B + 95; \text{ and}$$

the fourth aerodynamic force angle,  $\theta_{F4}$ , satisfies the condition

$$95.4SG_B^2 - 156.4SG_B + 104 \geq \theta_{F4} \geq 95.4SG_B^2 - 156.4SG_B + 99;$$

wherein  $SG_B$  is the specific gravity of the golf ball in g/cc.

11. The golf ball of claim 9, wherein the layer  $L_3$  is formed from at least one of a thermoset or thermoplastic composition.

12. The golf ball of claim 11, wherein the thermoset or thermoplastic composition comprises one or more of a polyurethane, polyurea, polyurethane/polyurea hybrids, or ionomer.

13. The golf ball of claim 12, wherein the thermoset or thermoplastic composition comprises a partially neutralized polymer.

14. The golf ball of claim 12, wherein the thermoset or thermoplastic composition comprises a highly neutralized polymer.

\* \* \* \* \*