



(19) **United States**

(12) **Patent Application Publication**
Luebben et al.

(10) **Pub. No.: US 2021/0287719 A1**

(43) **Pub. Date: Sep. 16, 2021**

(54) **ELECTRONIC DEVICE THAT INCLUDES A COMPOSITION THAT CAN ACTIVELY GENERATE AND RELEASE A GASEOUS OXIDIZING AGENT COMPONENT INTO AN INTERIOR SPACE OF THE ELECTRONIC DEVICE, AND RELATED SUBASSEMBLIES AND METHODS**

(60) Provisional application No. 62/884,027, filed on Aug. 7, 2019, provisional application No. 62/936,816, filed on Nov. 18, 2019.

Publication Classification

(51) **Int. Cl.**
G11B 33/02 (2006.01)
H05K 5/02 (2006.01)
G11B 33/14 (2006.01)
(52) **U.S. Cl.**
CPC *G11B 33/022* (2013.01); *G11B 33/1486* (2013.01); *G11B 33/1466* (2013.01); *H05K 5/0217* (2013.01)

(71) Applicant: **Seagate Technology LLC**, Fremont, CA (US)
(72) Inventors: **Silvia De Vito Luebben**, Golden, CO (US); **Rory S. Goodman**, Boulder, CO (US); **Paul S. Tyler**, Apple Valley, MN (US); **Paul A. Beatty**, Fort Collins, CO (US); **Dipeshkumar J. Purani**, Shakopee, MN (US); **Kendall H. Fung**, Longmont, CO (US); **Philip W. Viet**, Fremont, CA (US)

(57) **ABSTRACT**
The present disclosure relates to electronic devices that include a composition that actively generates a gaseous oxidizing agent component within the interior gas space of the electronic device. The present disclosure also relates to electronic devices that include a container that includes a gaseous oxidizing agent component in a manner that the gaseous oxidizing component can transfer from the container to the interior gas space of the electronic device. The present disclosure also involves related methods.

(21) Appl. No.: **17/325,980**

(22) Filed: **May 20, 2021**

Related U.S. Application Data

(63) Continuation of application No. 16/944,573, filed on Jul. 31, 2020, now Pat. No. 11,024,343.

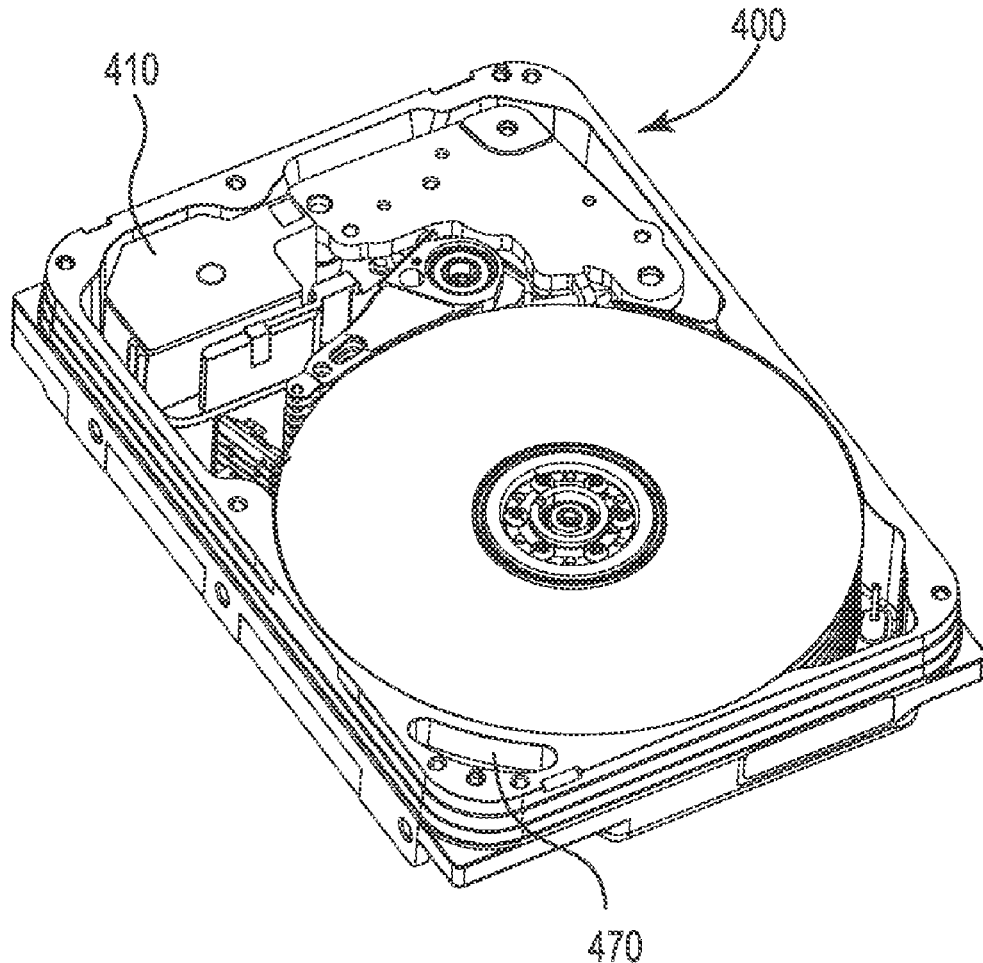

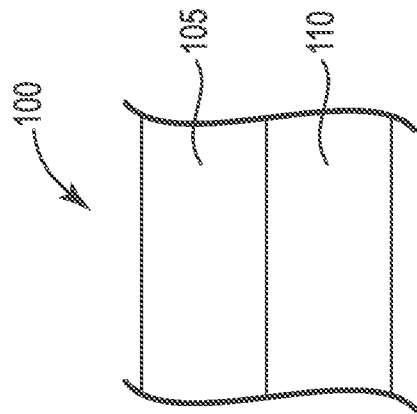

FIG. 1A

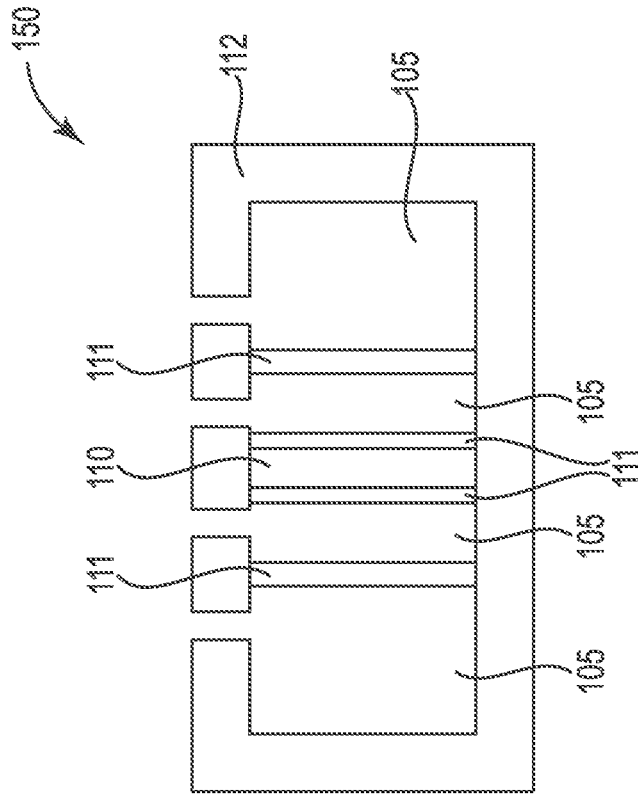

FIG. 1B

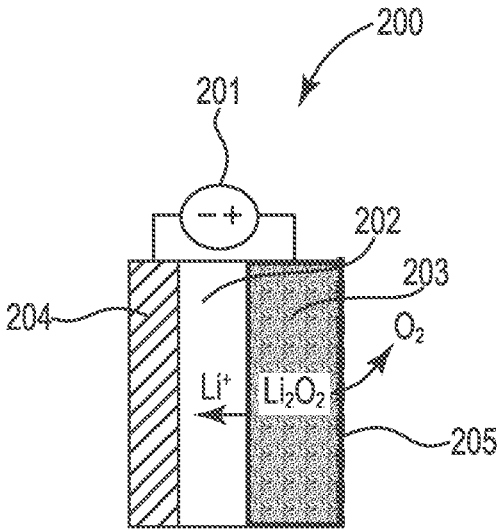

FIG. 2

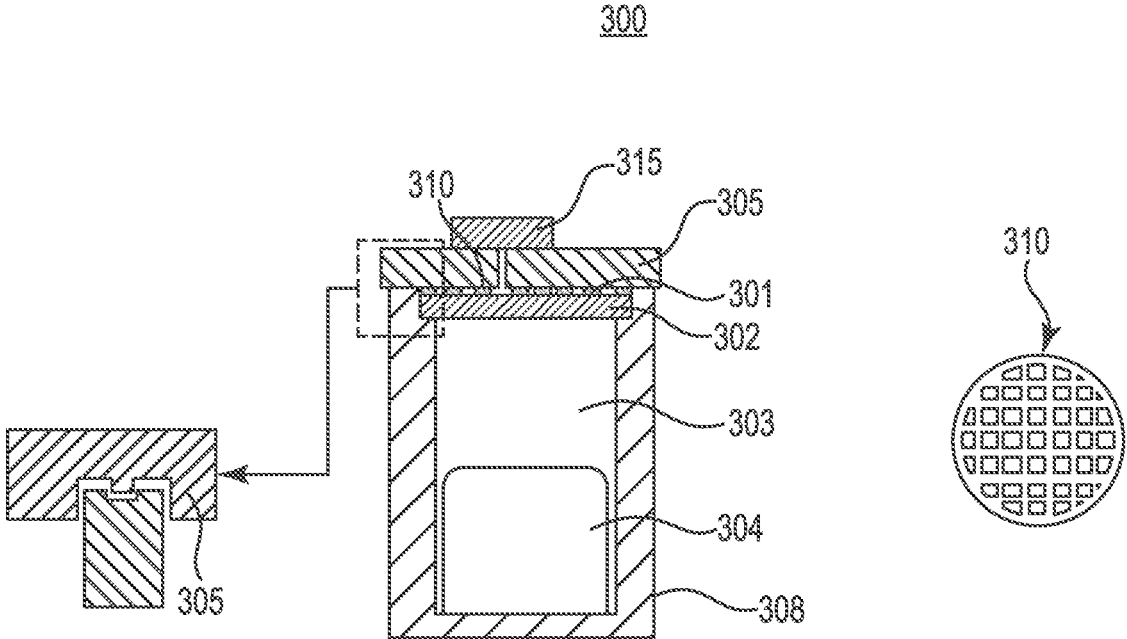

FIG. 3

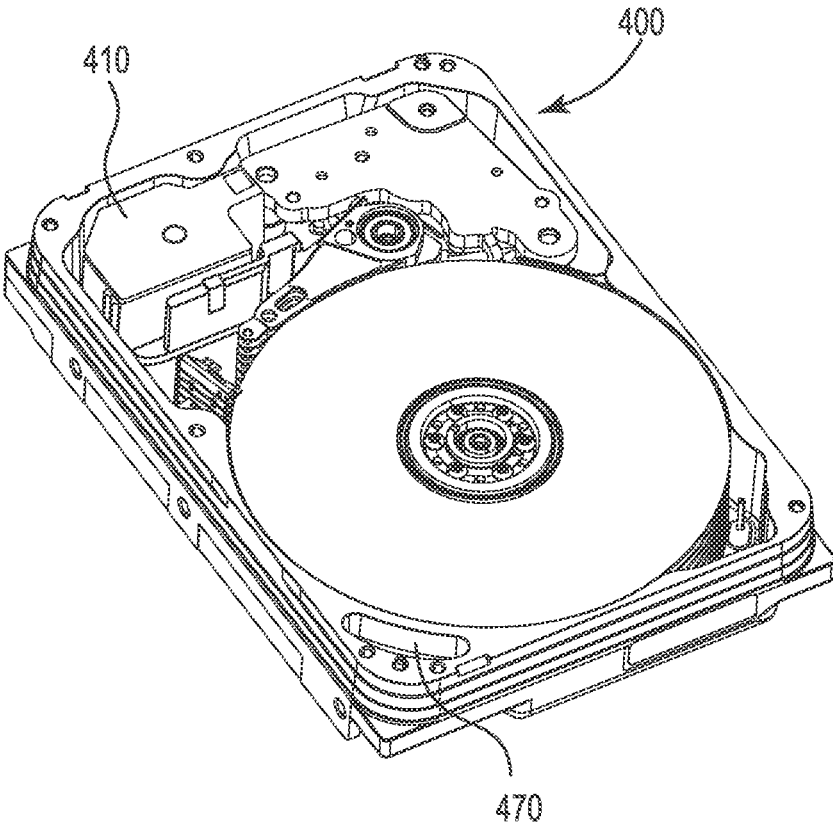

FIG. 4A

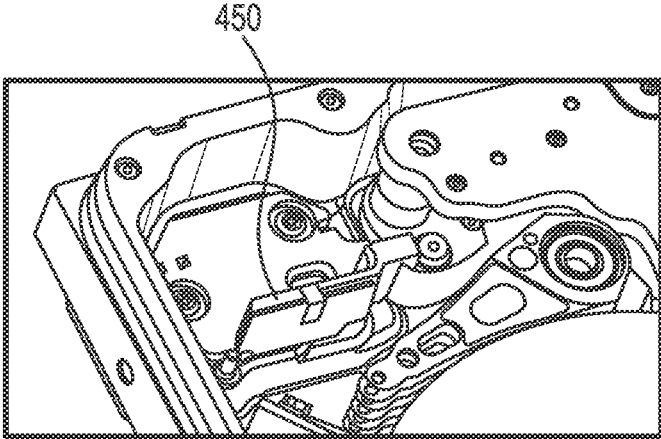

FIG. 4B

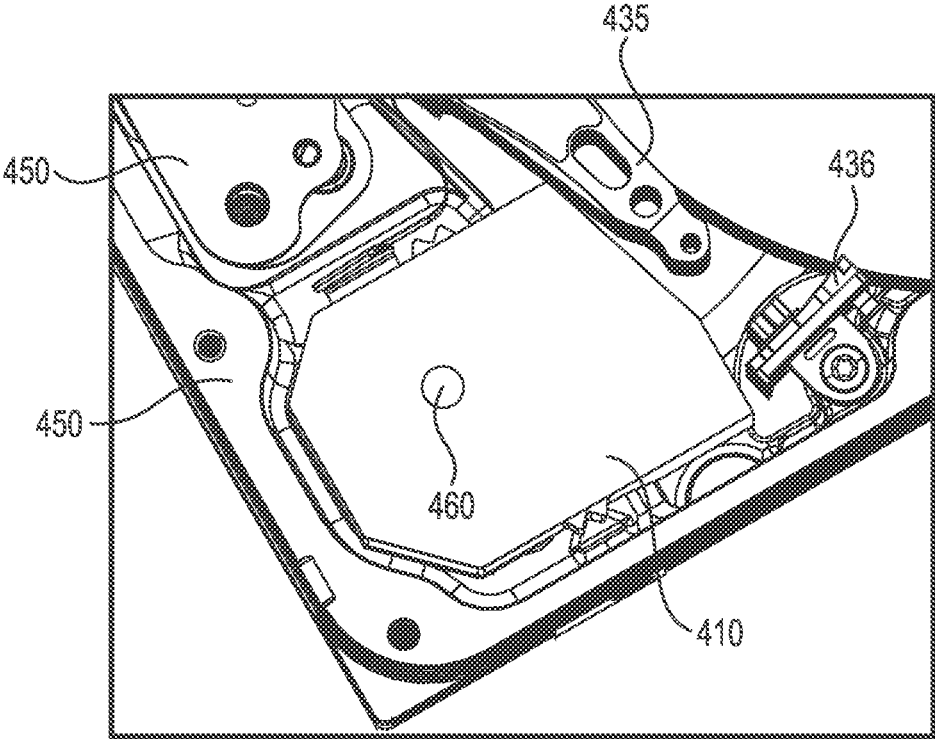

FIG. 4C

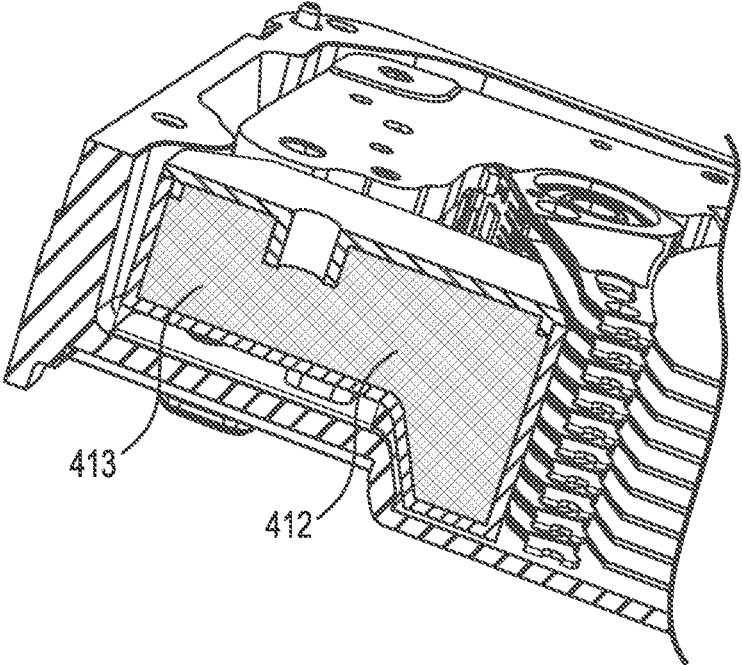

FIG. 4D

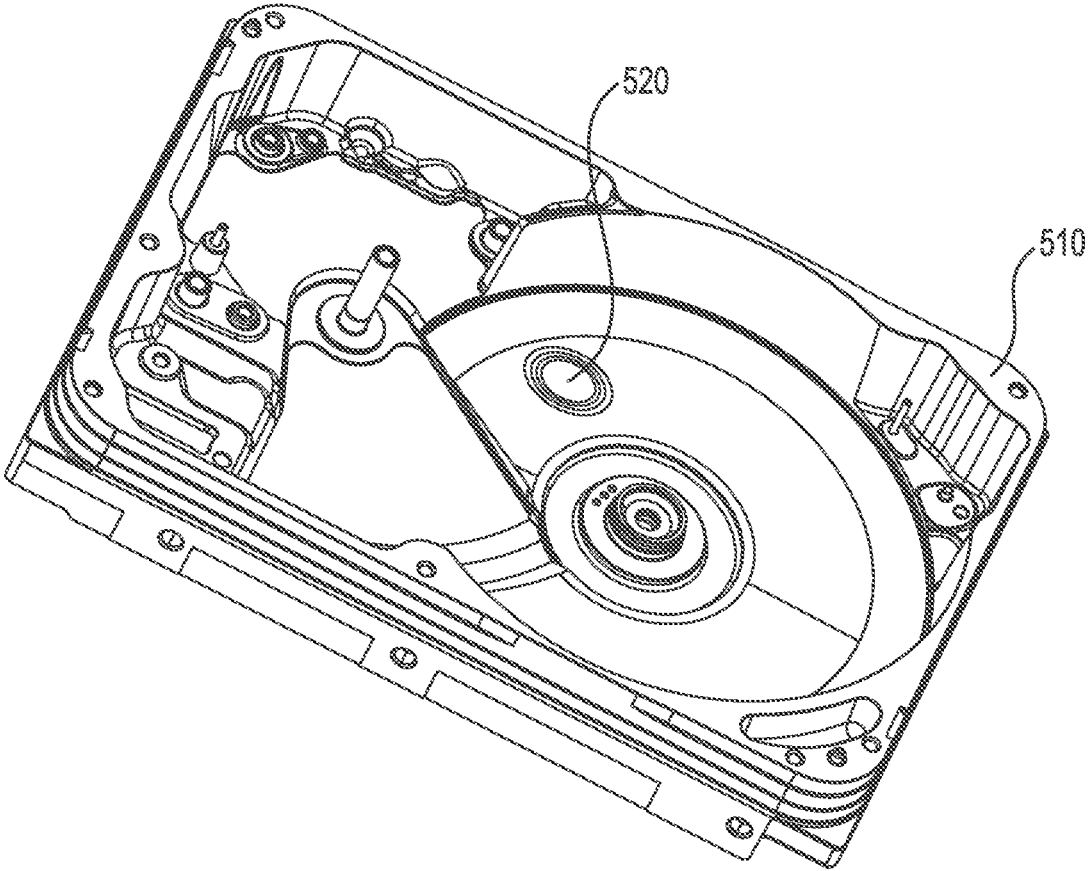
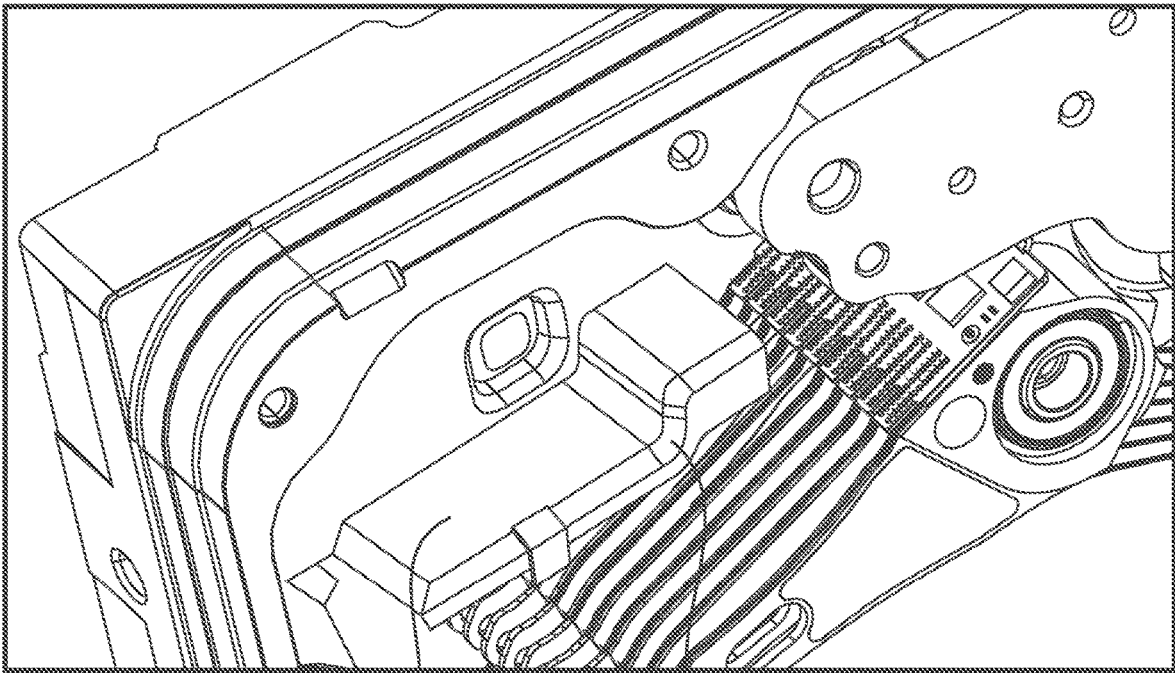

FIG. 5



610

650

FIG. 6

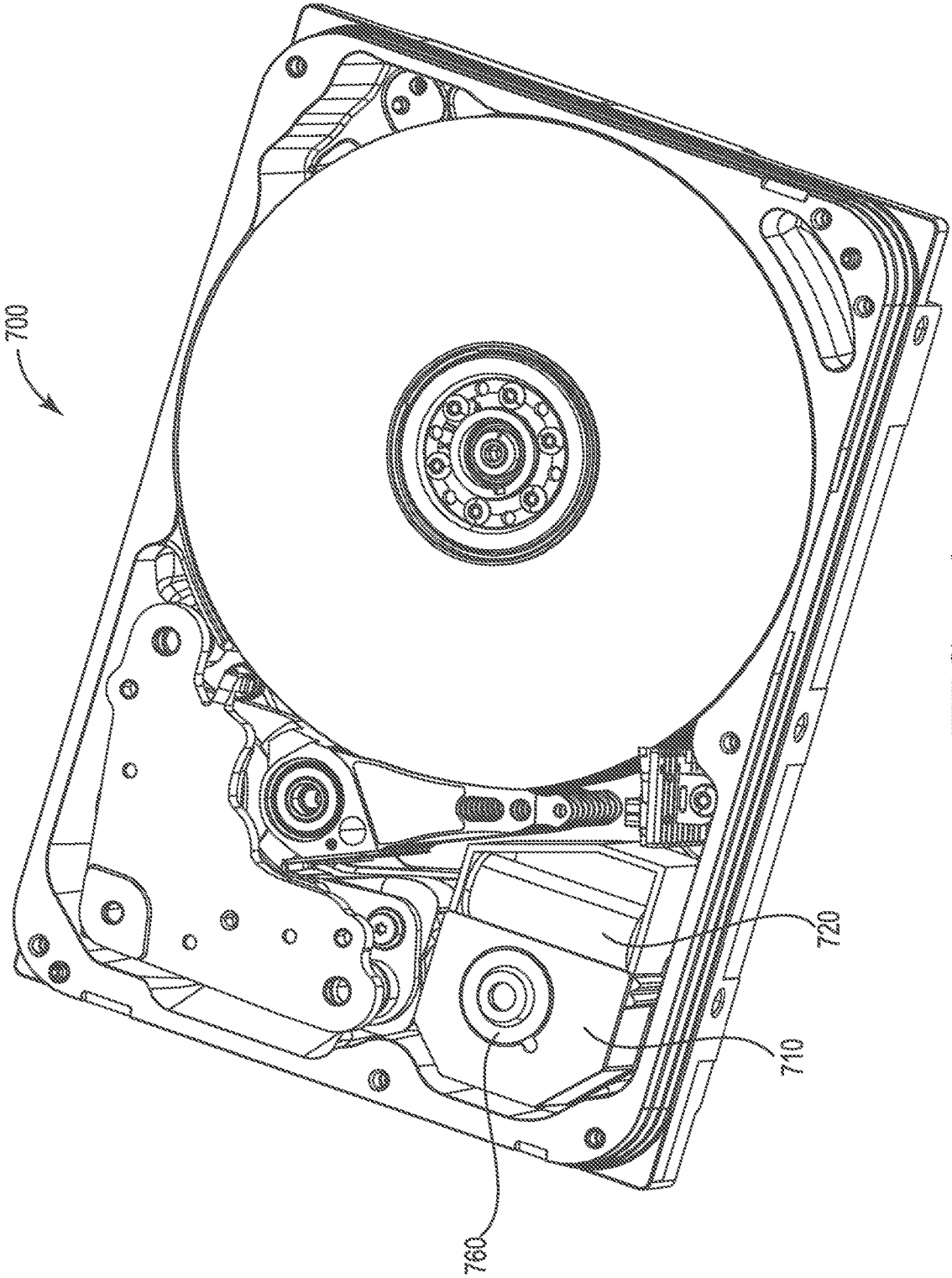

FIG. 7A

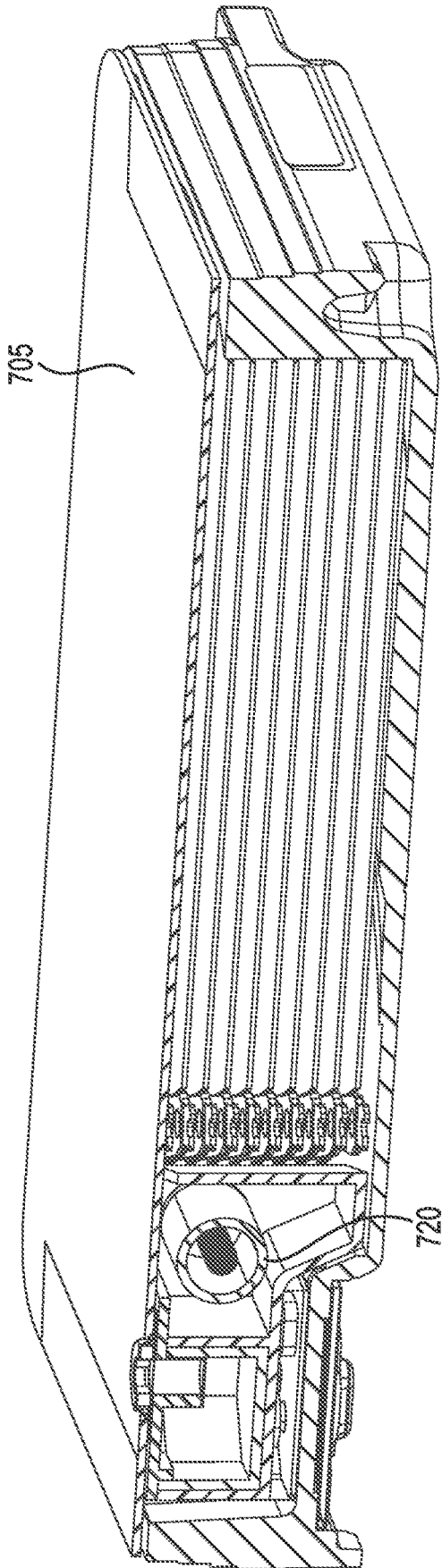

FIG. 7B

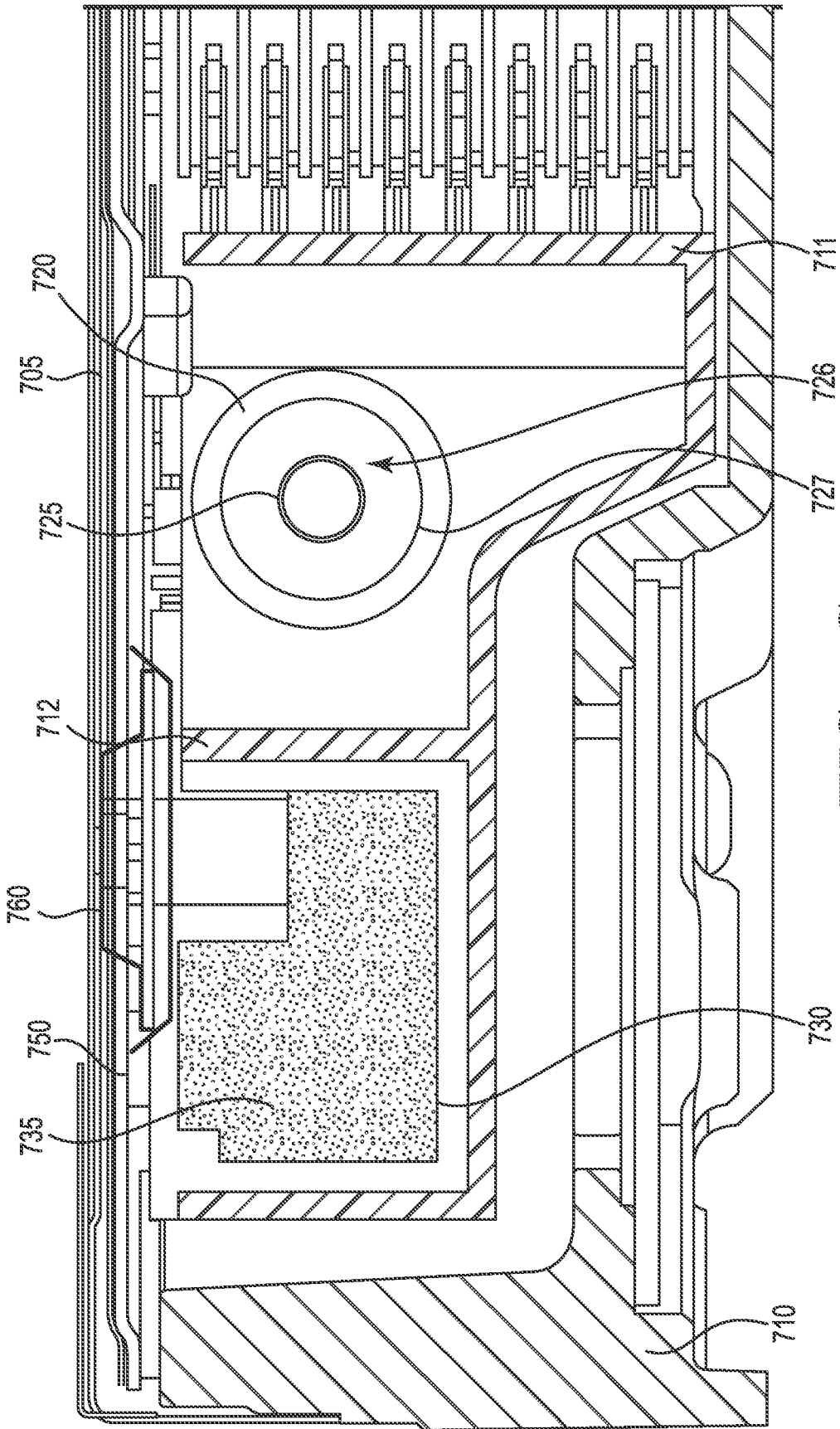

FIG. 7C

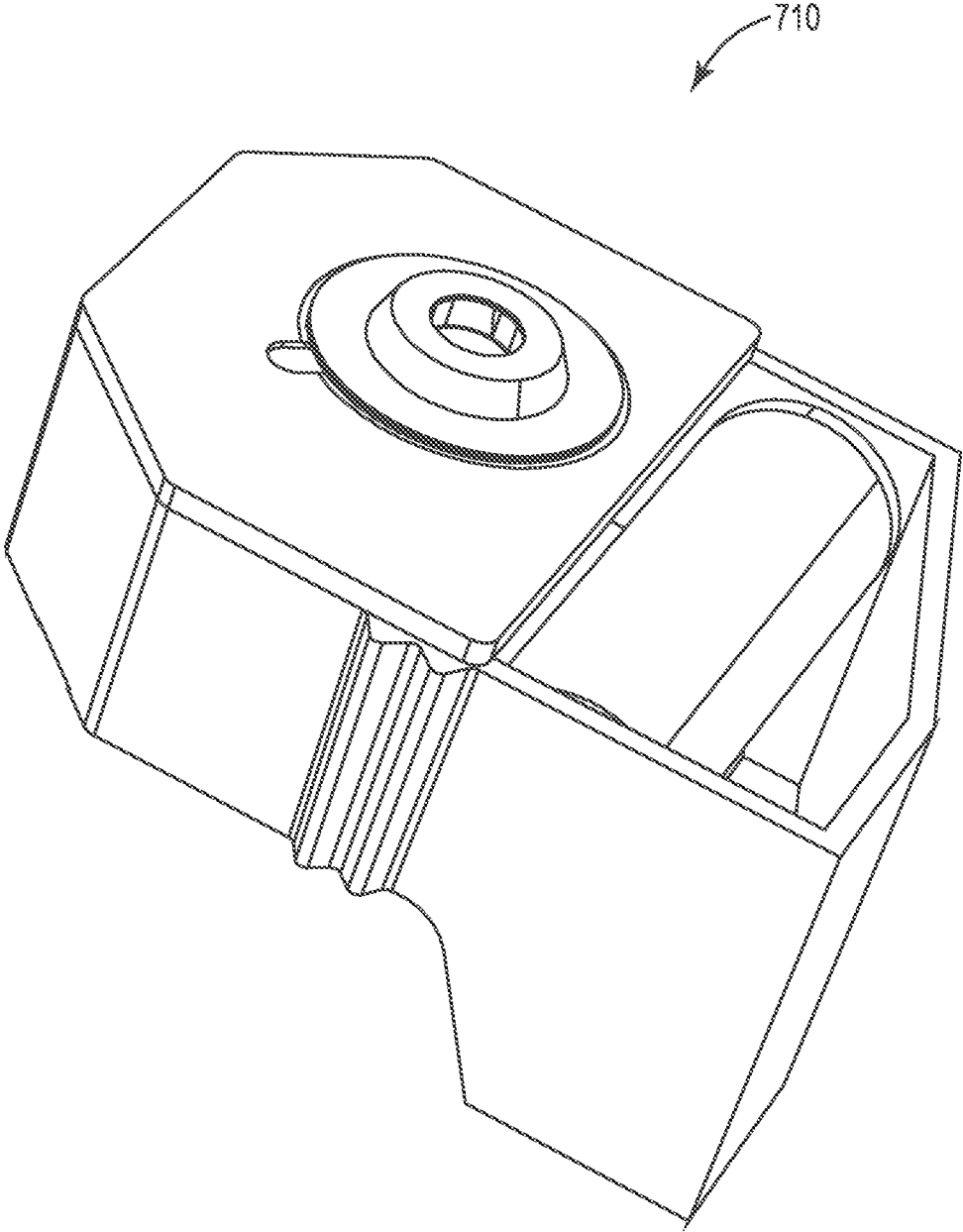

FIG. 7D

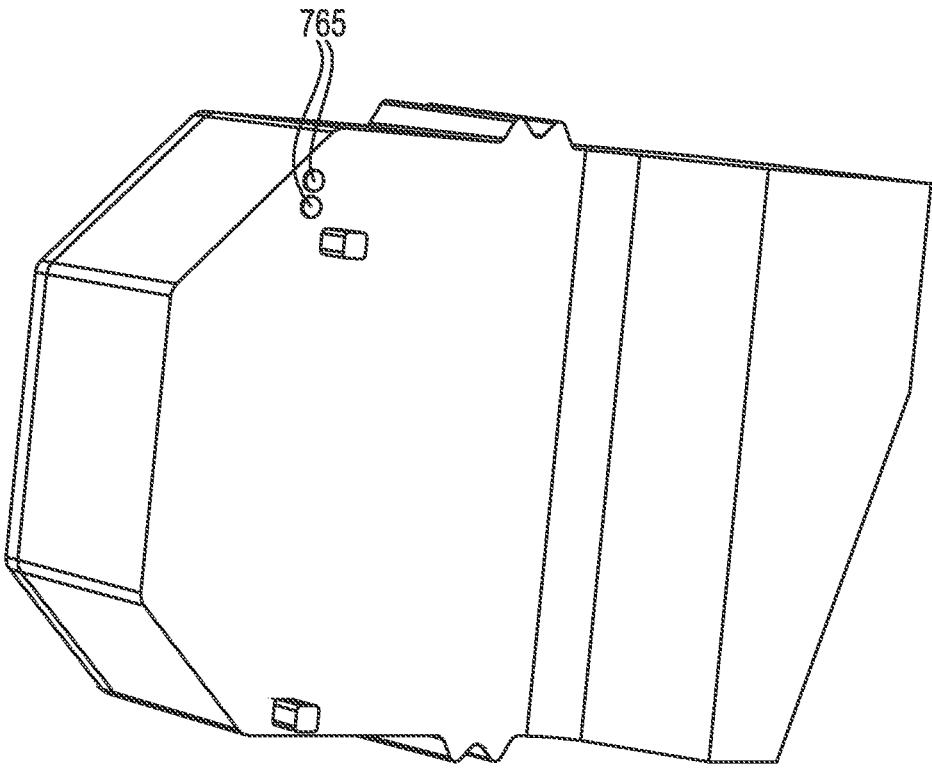

FIG. 7E

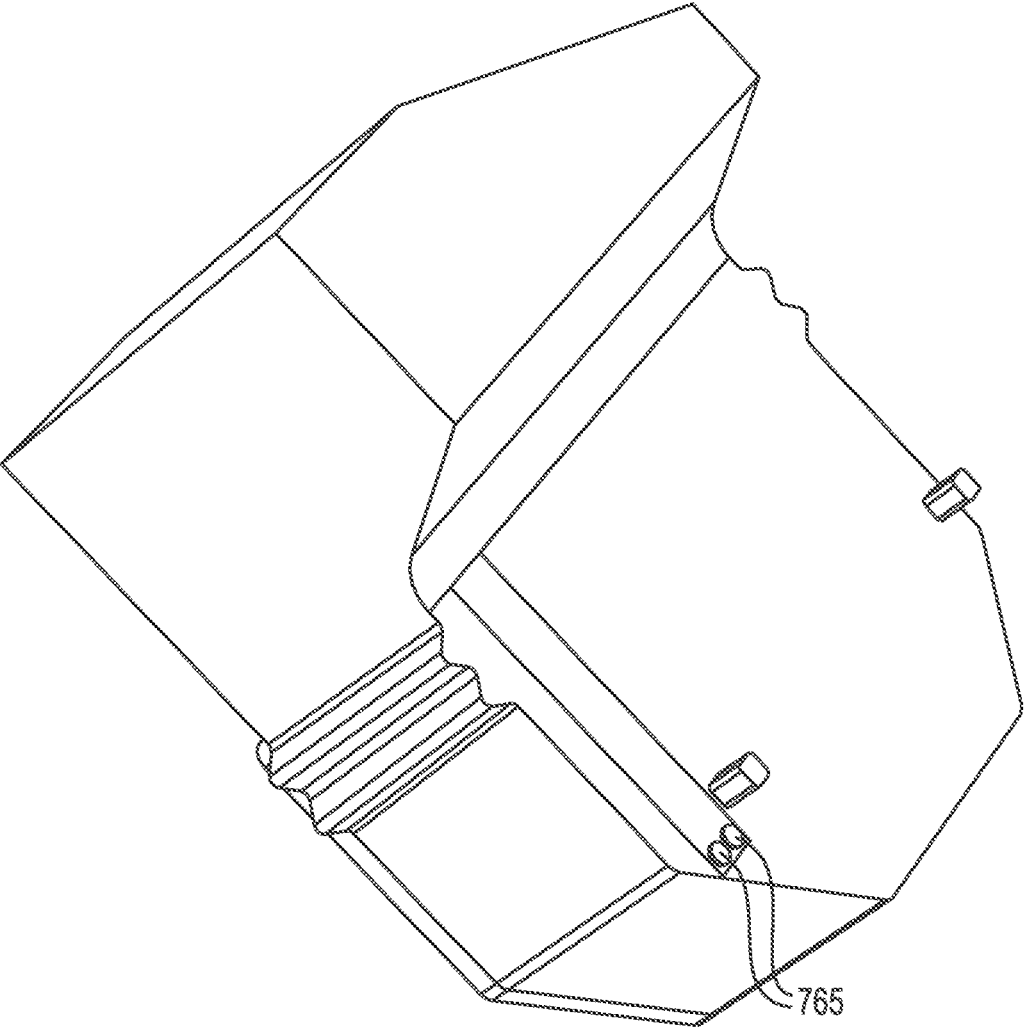

FIG. 7F

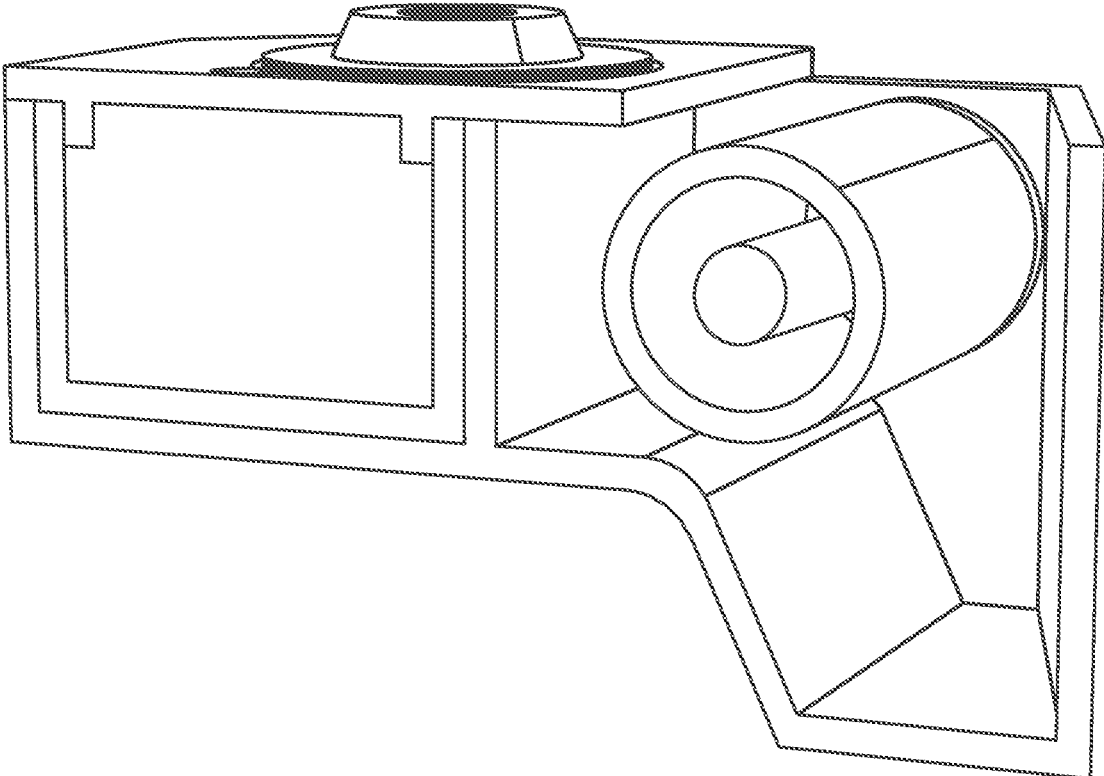

FIG. 7G

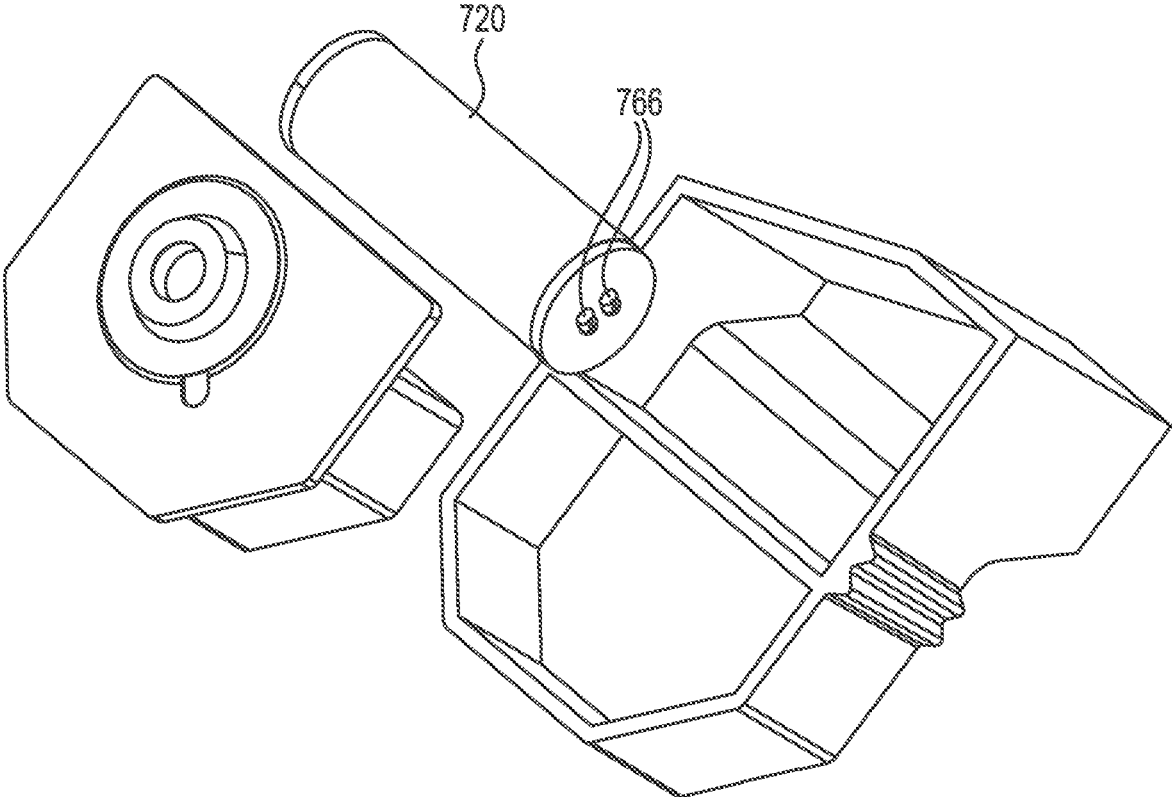

FIG. 7H

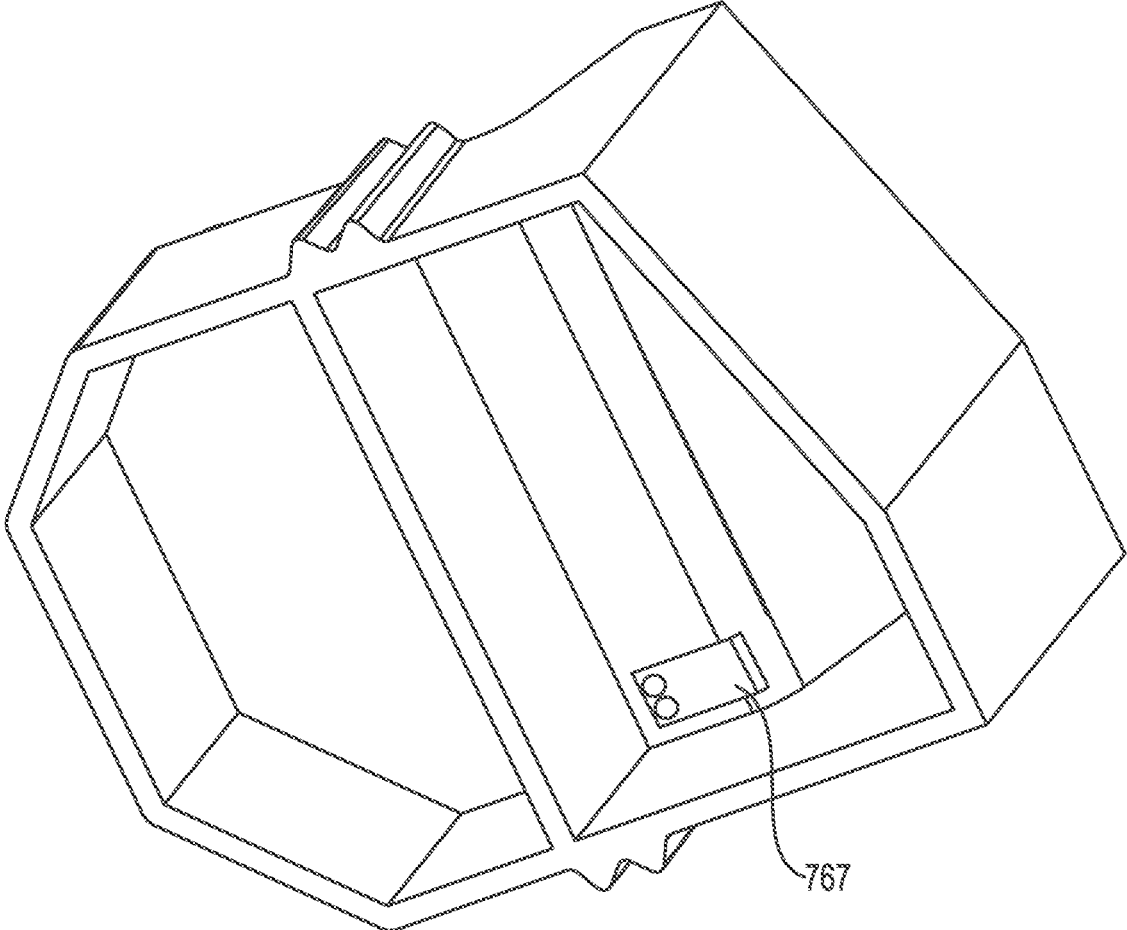

FIG. 7I

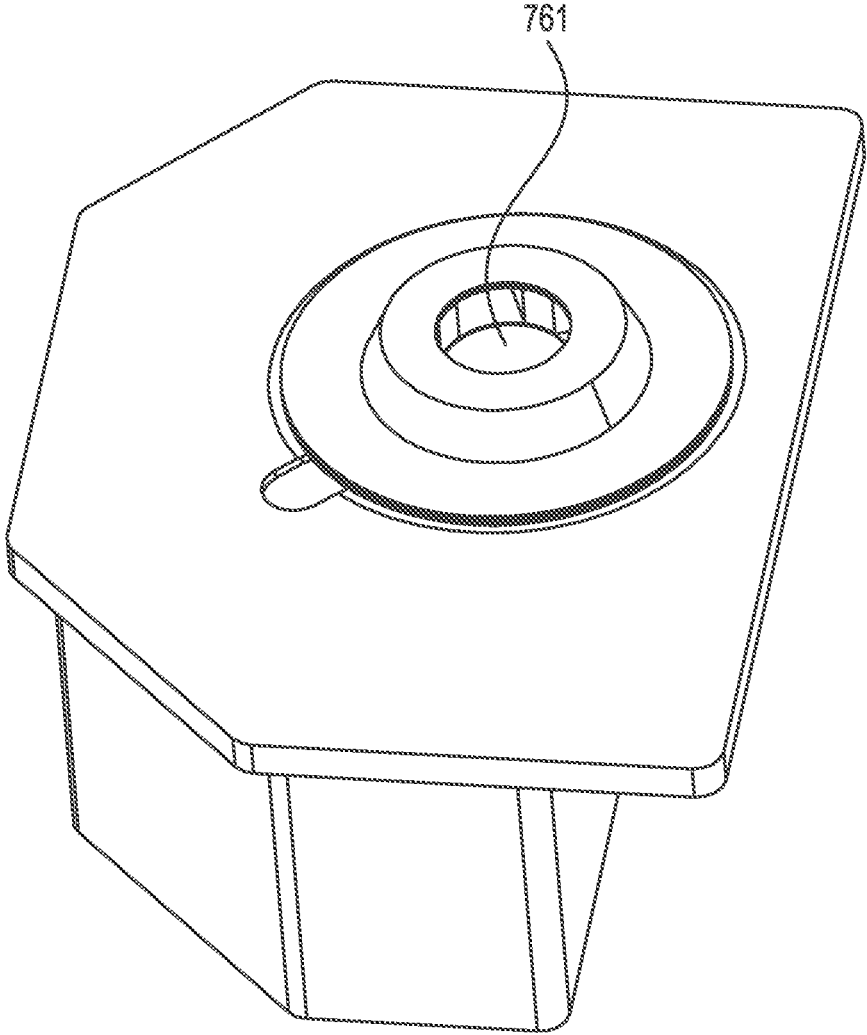

FIG. 7J

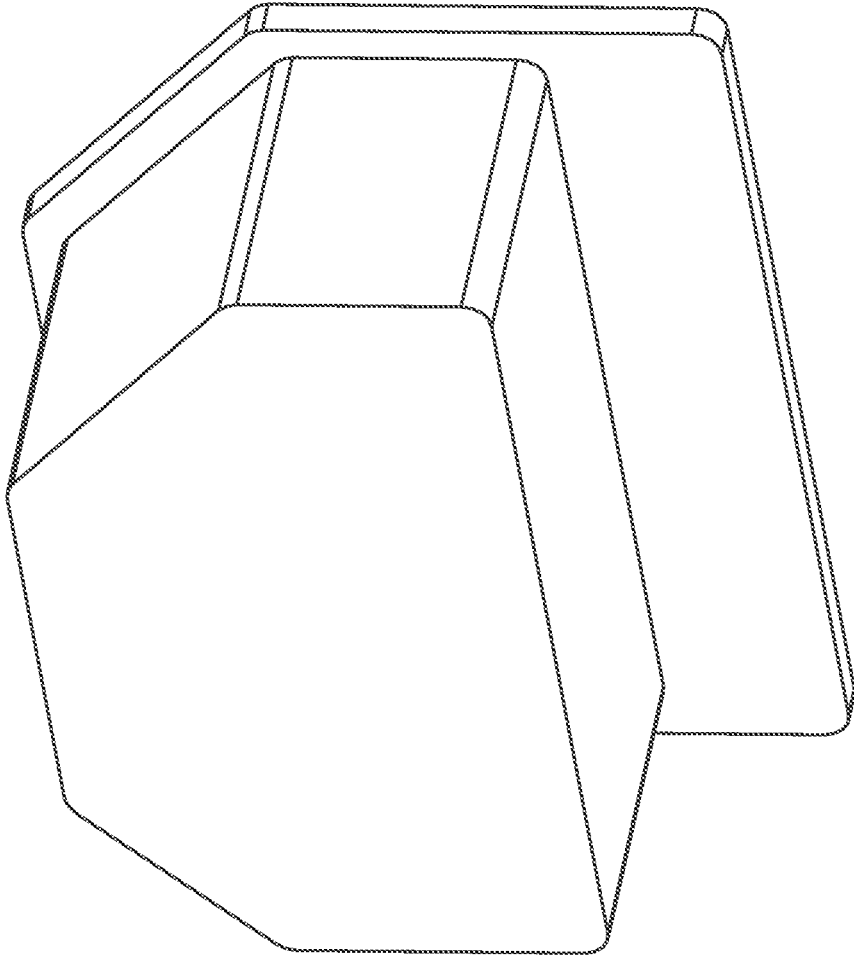

FIG. 7K

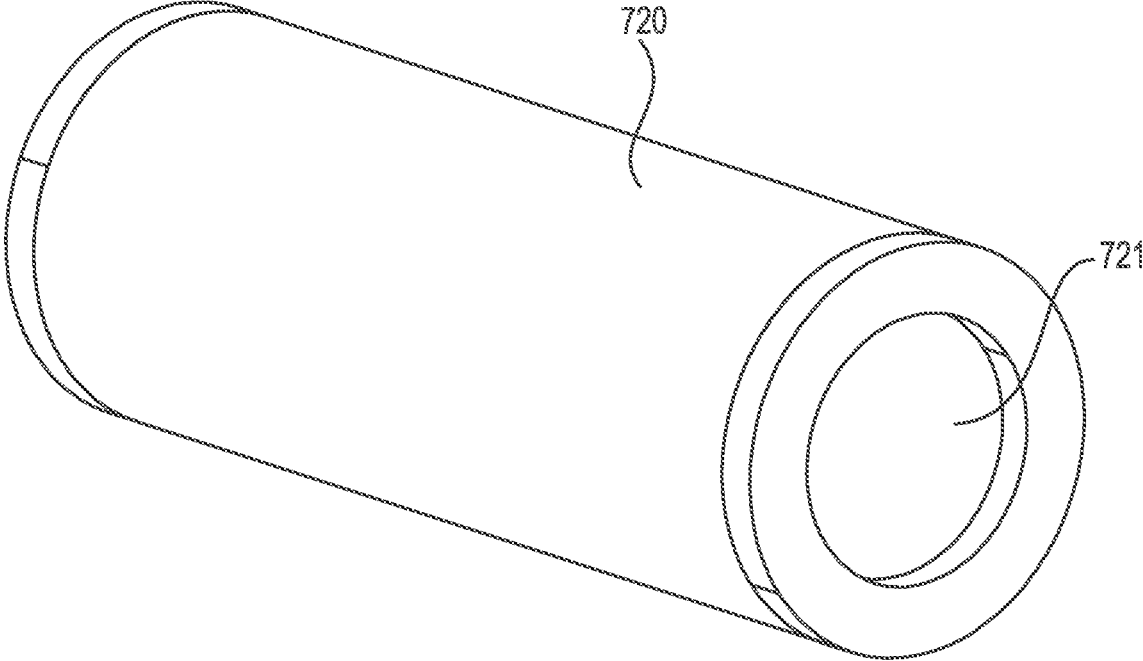

FIG. 7L

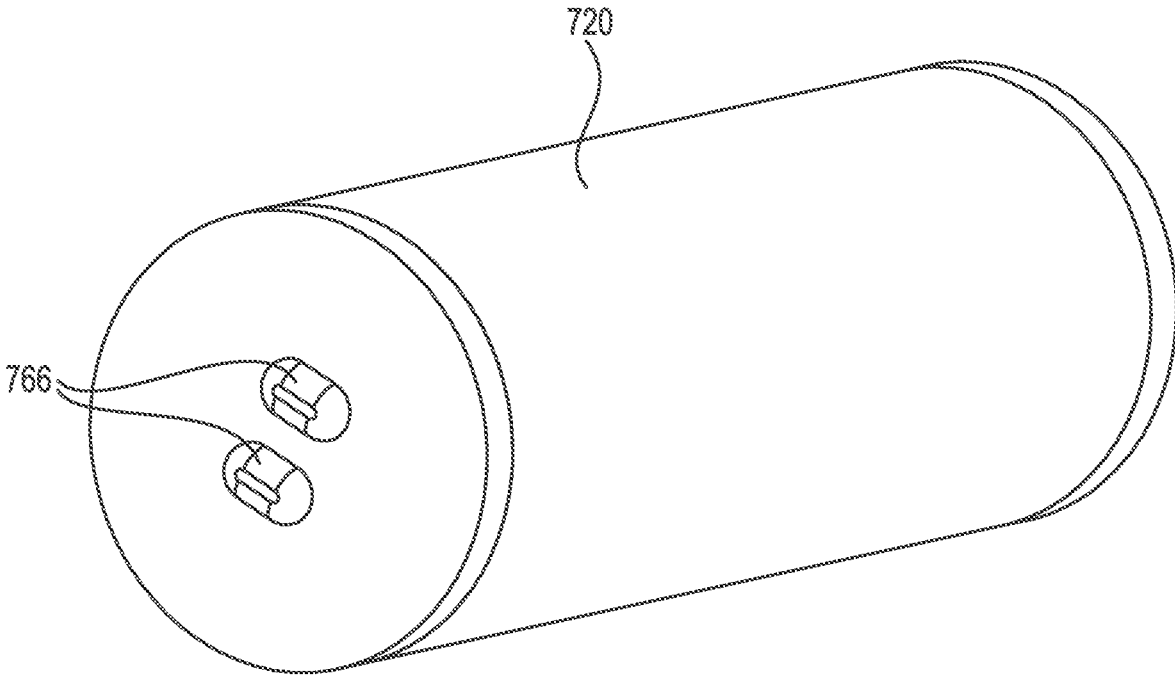

FIG. 7M

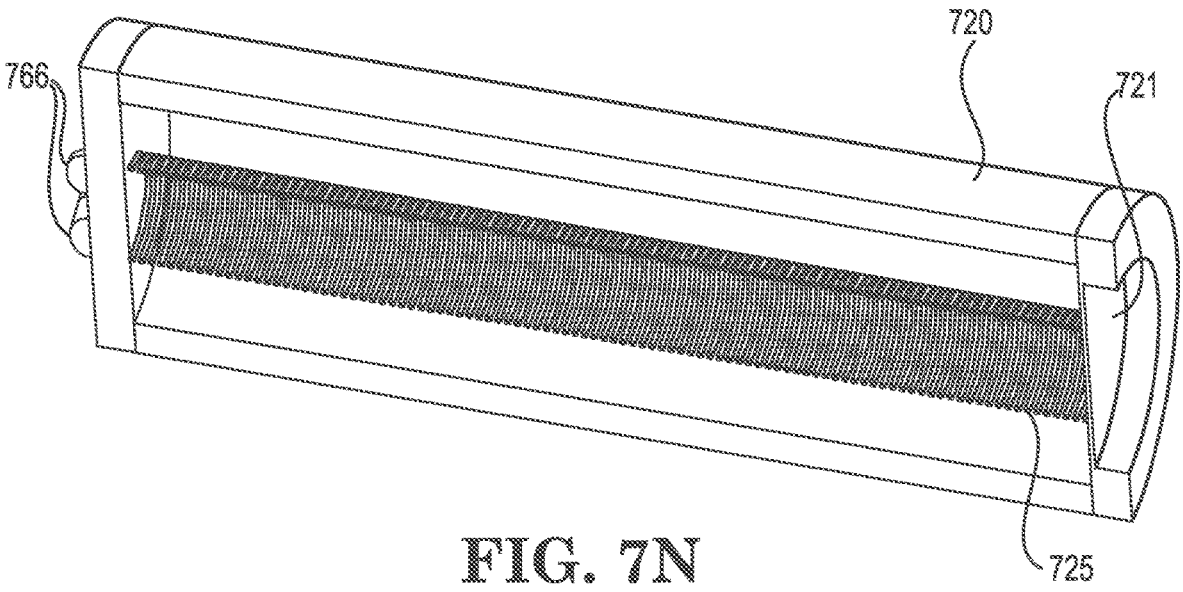

FIG. 7N

ELECTRONIC DEVICE THAT INCLUDES A COMPOSITION THAT CAN ACTIVELY GENERATE AND RELEASE A GASEOUS OXIDIZING AGENT COMPONENT INTO AN INTERIOR SPACE OF THE ELECTRONIC DEVICE, AND RELATED SUBASSEMBLIES AND METHODS

CROSS-REFERENCE TO RELATED APPLICATIONS

[0001] This application is a continuation patent application of nonprovisional patent application Ser. No. 16/944,573 filed on Jul. 31, 2020, which in turn claims the benefit of commonly owned provisional applications: Ser. No. 62/884,027, filed on Aug. 7, 2019; and Ser. No. 62/936,816, filed on Nov. 18, 2019; wherein the entirety of each of said applications is incorporated herein by reference.

[0002] The present continuation application is related to patent application having application Ser. No. 16/944,516 filed on Jul. 31, 2020, by Luebben et al., titled “ELECTRONIC DEVICE THAT INCLUDES A COMPOSITION THAT CAN RELEASE AND OPTIONALLY GENERATE A GASEOUS OXIDIZING AGENT COMPONENT INTO AN INTERIOR SPACE OF THE ELECTRONIC DEVICE, AND RELATED SUBASSEMBLIES AND METHODS”, wherein the entirety of said nonprovisional application is incorporated herein by reference.

BACKGROUND

[0003] The present disclosure relates to electronic devices such as data storage devices like hard disk drives (HDDs) (internal and/or external), network attached storage (NAS), and the like. There is a continuing need to solve problems related to maintaining internal, electronic drive components in as-built conditions for the service life of the electronic device.

SUMMARY

[0004] The present disclosure includes embodiments of an electronic device including:

- [0005]** a) a housing having an interior gas space;
 - [0006]** b) one or more electronic components disposed within the housing;
 - [0007]** c) a composition that can actively generate a gaseous oxidizing agent component, wherein the composition includes a stabilizer that can slow down the generation of the gaseous oxidizing agent; and
 - [0008]** d) a generating device configured to actively cause the composition to generate the gaseous oxidizing agent component.
- [0009]** The present disclosure includes embodiments of an electronic device including:
- [0010]** a) a housing having an interior gas space;
 - [0011]** b) one or more electronic components disposed within the housing;
 - [0012]** c) a composition that can actively generate a gaseous oxidizing agent component, wherein the composition includes at least two reactants that react with each other to generate gaseous oxidizing agent component, and wherein a barrier is positioned between the at least two reactants to slow down the generation of the gaseous oxidizing agent; and

[0013] d) a generating device configured to actively cause the composition to generate the gaseous oxidizing agent component.

[0014] The present disclosure includes embodiments of an electronic device including:

- [0015]** a) a housing having an interior gas space;
- [0016]** b) one or more electronic components disposed within the housing;
- [0017]** c) a composition that can actively generate a gaseous oxidizing agent component;
- [0018]** d) a generating device configured to actively cause the composition to generate the gaseous oxidizing agent component; and
- [0019]** e) a container disposed within the electronic device, wherein the composition that can generate a gaseous oxidizing agent component is disposed within the container, wherein the container is configured to allow gaseous oxidizing agent component to transfer from inside the container to the interior gas space of the housing, wherein the container is configured to passively and/or actively allow gaseous oxidizing agent component to be controllably transferred from inside the container to the interior gas space of the housing.

[0020] The present disclosure includes embodiments of an electronic device including:

- [0021]** a) a housing having an interior gas space;
- [0022]** b) one or more electronic components disposed within the housing;
- [0023]** c) a composition that can actively generate a gaseous oxidizing agent component; and
- [0024]** d) a generating device configured to actively cause the composition to generate the gaseous oxidizing agent component, wherein the generating device includes one or more heating elements in thermal contact with the composition, wherein the one or more heating elements are in electrical communication with a power source that is configured to apply power to the one or more heating elements in an on/off manner according to a predetermined time interval to heat the composition to a temperature that causes the composition to decompose to generate the gaseous oxidizing agent component.

[0025] The present disclosure includes embodiments of an electronic device including:

- [0026]** a) a housing having an interior gas space;
 - [0027]** b) one or more electronic components disposed within the housing;
 - [0028]** c) a composition that can generate a gaseous oxidizing agent component, wherein the composition is in a form chosen from powder, granules, pellets, and combinations thereof; and
 - [0029]** d) a generating device configured to actively cause the composition to generate the gaseous oxidizing agent component.
- [0030]** The present disclosure includes embodiments of an electronic device including:
- [0031]** a) a housing having an interior gas space;
 - [0032]** b) one or more electronic components disposed within the housing;
 - [0033]** c) a composition that can generate a gaseous oxidizing agent component; and
 - [0034]** d) a generating device configured to actively cause the composition to generate the gaseous oxidizing agent component, wherein the generating device includes at least one metal-air battery that is in electrical communication

with a power source that is configured to apply power to the metal-air battery according to a predetermined time interval to recharge the metal-air battery to generate the gaseous oxidizing agent component.

BRIEF DESCRIPTION OF THE DRAWINGS

[0035] FIG. 1A shows a cross-section schematic of one embodiment of a device for actively generating a gaseous oxidizing agent component;

[0036] FIG. 1B shows a cross-section schematic of another embodiment of a device for actively generating a gaseous oxidizing agent component;

[0037] FIG. 2 shows a schematic representation of a metal air battery that can be used in an electronic device according to the present disclosure;

[0038] FIG. 3 shows a non-limiting example of a dual chamber container 300 with a permeation layer and micro-valve, which works like a 2-stage regulator;

[0039] FIGS. 4A-4D illustrate one non-limiting embodiment according to the present disclosure of including a composition that can generate a gaseous oxidizing agent component into a hard disk drive

[0040] FIG. 5 illustrates another non-limiting embodiment according to the present disclosure of including a composition that can generate a gaseous oxidizing agent component into a hard disk drive;

[0041] FIG. 6 illustrates another non-limiting embodiment according to the present disclosure of including a composition that can be actively controlled to generate a gaseous oxidizing agent component into a hard disk drive; and

[0042] FIGS. 7A-7N illustrate another non-limiting embodiment according to the present disclosure of including a composition that can be actively controlled to generate a gaseous oxidizing agent component in a hard disk drive.

DETAILED DESCRIPTION

[0043] The present disclosure relates to electronic devices that include a composition that is actively controlled to generate a gaseous oxidizing agent component within the interior gas space of the electronic device. The present disclosure also relates to electronic devices that include a container that includes a gaseous oxidizing agent component in a manner that the gaseous oxidizing component can transfer from the container to the interior gas space of the electronic device.

[0044] A wide variety of electronic devices having an interior space and one or more electronic components disposed within the interior space can benefit by having a container that includes a gaseous oxidizing agent component that can be released into the interior space and/or a composition that generates a gaseous oxidizing agent component after the electronic device is assembled and during at least a portion of its service life as described herein. In some embodiments, an electronic device is a data storage device. Non-limiting examples of data storage devices include hard disk drives (internal and/or external), network attached storage (NAS), and the like. Examples of hard disc drives are reported in U.S. Pat. No. 7,478,760 (Beatty et al.) and U.S. Pat. No. 7,695,547 (Smith), wherein the entireties of said patents are incorporated herein by reference.

[0045] For example, in some embodiments, for desirable performance and reliability characteristics in disk drives an operating atmosphere can include an initial fill of a gas

mixture that includes primarily helium gas and a second minor gas fraction consisting of a gaseous oxidizing agent component (oxidizer) for the entire operational life of the drive. The purpose of the primarily helium environment is to reduce gas turbulence induced vibration of the drives internal components to facilitate track follow capability across disk track widths of 100 nm or less. The second minor gas component, the gaseous oxidizing agent component can oxidize inorganic and/or organic materials and limit their accumulation on one or more components within the interior of an electronic device such as a hard disk drive as desired (e.g., to maintain one or more electronic components within the interior space in as-built conditions). Chemical reactions between the gaseous oxidizing agent component and inorganic and/or organic materials is believed to result in the formation of gaseous by-products that are free to transport away.

[0046] It has been observed that the concentration of oxygen contained in welded HDDs can unfortunately decrease over time. The rate of decrease of oxygen concentration can depend on a variety of factors such as one or more drive operating conditions. The loss of oxygen over time can be attributed to chemical reactions between oxygen and internal drive components. Such internal drive components include, but are not limited to, the recording media, activated carbon, and ferrous metal components. The measured rate of loss of oxygen is expected to result in the oxygen concentration dropping below a desired concentration over the service life of the HDD.

[0047] The interior gas space of an electronic device can include helium gas to maintain sufficient vibration mitigation. As the fraction of helium is decreased (e.g., from 100%), the vibrational performance of the drive mechanics can degrade, suggesting it can be beneficial to limit the non-helium oxidizing gas constituents to a minimum mole fraction as desired. the helium gas is present in the interior gas space at a mole fraction of 99 percent or less based on the total gas in the interior gas space (e.g., from 80 to 99 percent, from 80 to 95 percent, from 85 to 95 percent, or even from 85-90 percent).

[0048] The interior gas space of an electronic device can have a nominal relative humidity of 20% or less at 25° C., 15% or less at 25° C., 10% or less at 25° C., 5% or less at 25° C., or even 1% or less at 25° C.

[0049] In some embodiments, an electronic device can be a hermetically sealed electronic device, which can be defined by, e.g., the amount of gas that leaks from the electronic device after it has been sealed (e.g., a welded HDD). In some embodiments, the interior gas space includes helium gas and the hermetically sealed electronic device has a helium leak rate of 50×10^{-8} atm (atmosphere) cc (cubic centimeter)/second or less at 25° C.; 20×10^{-8} atm cc/second or less, 10×10^{-8} atm cc/second or less; 5×10^{-8} atm cc/second or less at 25° C.; or even 4.2×10^{-8} atm cc/second or less at 25° C.

[0050] The present disclosure involves maintaining the concentration of a gaseous oxidizing agent component in the interior gas space of an electronic device within a desirable range over a variety of operating conditions and for a given time period (e.g., throughout the life of the drive). Maintaining a gaseous oxidizing agent component has the advantage of maintaining the helium mole fraction at a desired level to help provide a favorable mechanical vibration environment, while at the same time maintaining a desired

supply of a gaseous oxidizing agent component to reduce or prevent performance impairment of one or more internal, electronic drive components due to insufficient oxidizer supply.

[0051] According to one aspect, the present disclosure includes approaches for actively generating a gaseous oxidizing agent component from a composition at a rate selected to maintain a desired concentration of the gaseous oxidizing agent component as described herein. As used herein, “a gaseous oxidizing agent component” includes one or more oxidizing agent species. Nonlimiting examples of oxidizing agent species include atomic oxygen, molecular oxygen, ozone, nitrous oxide, hydrogen peroxide, oxygen radical, dioxygen radicals, and mixtures thereof.

[0052] A type and amount of a composition that generates a gaseous oxidizing agent component can be selected based on one or more factors such as the target mole fraction of gaseous oxidizing agent component in the interior space of an electronic device; the temperature or range of temperatures at which the composition generates a gaseous oxidizing agent component; the operating temperature of an electronic device, which the composition will be exposed to; the service life of the electronic device; and the like. In some embodiments, the composition can be included in an electronic device that has been initially filled with a gas mixture of helium/oxidizing gas species when initially assembled.

[0053] In some embodiments, a composition that generates a gaseous oxidizing agent component is selected to be a type and in an amount to generate a gaseous oxidizing agent component so that the gaseous oxidizing agent component is maintained in the interior gas space at a mole fraction in the range from 0.1 to less than 20 mole percent based on the total gas in the interior gas space; a mole fraction in the range from 0.1 to 15 mole percent based on the total gas in the interior gas space; a mole fraction in the range from 0.1 to 10 mole percent based on the total gas in the interior gas space; a mole fraction in the range from 0.1 to 5 mole percent based on the total gas in the interior gas space; a mole fraction in the range from 0.5 to 5 mole percent based on the total gas in the interior gas space; a mole fraction in the range from 0.5 to 4 mole percent based on the total gas in the interior gas space; or even a mole fraction in the range from 1.5 to 3 mole percent based on the total gas in the interior gas space.

[0054] A composition that generates a gaseous oxidizing agent component is selected to be a type and in an amount to generate a gaseous oxidizing agent component so that the gaseous oxidizing agent component is maintained in the interior gas space at a desired mole fraction for a desired time period after the electronic device (e.g., hard disk drive) has been finally assembled and ready for service (e.g., at least a portion of the service life of the hard disk drive). In some embodiments, a composition that generates a gaseous oxidizing agent component is selected to be a type and in an amount to generate a gaseous oxidizing agent component so that the gaseous oxidizing agent component is maintained in the interior gas space at a desired mole fraction for a time period of at least two months, or even at least six months. In some embodiments, a composition that generates a gaseous oxidizing agent component is selected to be a type and in an amount to generate a gaseous oxidizing agent component so that the gaseous oxidizing agent component is maintained in the interior gas space at a desired mole fraction for a time

period of up to 3 years, up to 4 years, up to 5 years, up to 6 years, up to 7 years, up to 8 years, or even up to 9 years.

[0055] According to the present disclosure, a composition can be used to actively generate the gaseous oxidizing agent component. As used herein, “active” generation of gaseous oxidizing agent component refers to the controlled application of active mechanisms such as one or more of heat, light, electrochemical, injected electrons and/or water to oxygen liberating compounds to control the rate at which oxygen is produced. Active generation of gaseous oxidizing agent component is in contrast to passive generation of gaseous oxidizing agent component, which refers to the decomposition of materials or reaction of two or more compounds through their inherent physical and chemical properties resulting in the production of a gaseous oxidizing agent component.

[0056] A composition that generates a gaseous oxidizing agent component is selected to be a type and in an amount to activate the generation a gaseous oxidizing agent component at a desired rate at one or more temperatures above typical temperatures at which an electronic device operates at, thereby actively controlling the generation of gaseous oxidizing agent component. In some embodiments, a composition that generates a gaseous oxidizing agent component is selected to be a type and in an amount to generate a gaseous oxidizing agent component at a desired rate at a temperature greater than 60° C., greater than 80° C., greater than 100° C., greater than 110° C., or even greater than 120° C. In some embodiments, a composition that generates a gaseous oxidizing agent component is selected to be a type and in an amount to generate a gaseous oxidizing agent component at a desired rate at a temperature in the range from 100° C. to 200° C., from 110° C. to 180° C., or even from 120° C. to 160° C. In some embodiments, the composition can be selected so that it generates a gaseous oxidizing agent component at a sufficient rate so that the composition can last for a desired portion of the service life of the electronic device, as described above, while at the same time produce enough gaseous oxidizing agent component while the composition is activated to generate the gaseous oxidizing agent component.

[0057] Non limiting examples of generating oxidizing agent species are illustrated below. For example, Equations 1, 2, 3 and 4 below illustrate oxidizing agent species C that can be generated according to the present disclosure. In some embodiments, the oxidizing agent species C is molecular oxygen (O₂) and/or nitrous oxide due to their favorable stability.

[0058] In addition to the active mechanisms mentioned above to facilitate generating oxidizing agent species, one or more chemical components can be included in the chemical composition to modify the chemical reaction. In some embodiments, the rate of decomposition of A may be accelerated chemically. For example, a catalyst may be used to accelerate the rate of decomposition of A. In some embodiments, the rate of decomposition of A may be slowed down chemically. For example, a stabilizer may be used to slow down the rate of decomposition of A.

[0059] In some embodiments, as discussed below, if the decomposition of A occurs within a housing or container disposed in an electronic device. A container may include a barrier material (e.g., film) that can control the rate of diffusion of the oxidizing agent species C to the interior

space of the data storage device where it can oxidize inorganic and organic materials of transducer structures as desired.

[0060] In equations 1-4 below, A is a chemical composition for generating the oxidizing agent species C in the drive, B is a byproduct of the decomposition, C is the oxidizing agent species, D is a secondary byproduct of decomposition, and E is a catalyst, a stabilizer and/or a barrier. Non-limiting examples of by-products B and D include but are not limited to water, carbon dioxide, carbon monoxide, salts, halogenated compounds, metal oxides, sulfur containing species, nitrogen containing species (e.g., nitrogen oxides), etc., and mixtures thereof.



[0061] In some embodiments, molecular oxygen is the desired oxidizing agent species "C" as follows:

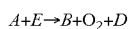
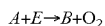
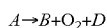

[0062] The chemical species A includes but is not limited to chemical compounds that contain an oxygen-oxygen bond including but not limited to hydrogen peroxide, peroxy compounds, organic peroxides, organic hydroperoxides, peracids, inorganic peroxides, inorganic hydroperoxides, percarbonates, perborates, perphosphates, persulfates, peroxyhydrate salts, oxygen inclusion compounds, certain oxides, and mixtures thereof. The chemical species A can also include compounds that complex or bind molecular oxygen, hydrogen peroxide, ozone, oxygen radical or dioxygen radical. The chemical species A can also include oxygen rich compounds such as chlorate salts, bromate salts, iodate salts, perchlorate salts, periodate salts, permanganate salts, chromate salts, etc.

[0063] In some embodiments, "A" includes calcium peroxide, magnesium peroxide, barium peroxide, zinc peroxide, cadmium peroxide, strontium peroxide, lithium peroxide, sodium peroxide, potassium peroxide, lithium nickel peroxide, potassium superoxide, sodium percarbonate, potassium percarbonate, calcium percarbonate, magnesium percarbonate, sodium perborate, sodium perborate tetrahydrate, potassium perborate, calcium perborate, magnesium perborate, potassium permanganate, sodium persulfate, potassium persulfate, and other peroxyhydrate salts such as potassium pyrophosphate peroxyhydrates and sodium sulfate-hydrogen peroxide-sodium chloride adduct, and mixtures thereof. In some embodiments, "A" includes calcium peroxide, magnesium peroxide, lithium peroxide, potassium superoxide, sodium peroxide, zinc peroxide, sodium percarbonate, sodium perborate, potassium persulfate and sodium persulfate, silver oxide, gold oxide and mixtures thereof. Peroxyhydrate salts useful in the present disclosure are described in U.S. Pat. Nos. 3,650,705, 3,140,149, 4,323,465, and U.S. Pat. No. 4,005,182, wherein the entirety of each patent document is hereby incorporated by reference.

[0064] In some embodiments, catalyst "E" includes one or more of transition metal oxides, transition metal compounds, manganese oxides, manganese compounds, potassium permanganate, copper oxides, copper compounds, nickel oxides, vanadium oxides, vanadium compounds, iron oxides, iron compounds, arsenic compounds, lead oxides, lead compounds, tin oxides, tin compounds, and mixtures thereof. An optional catalyst may be added to the oxygen generating compound in concentration of 0.1-10% wt. and more preferably from 1-5% wt.

[0065] As mentioned above, a composition A that decomposes into an oxidizing agent species C can be in a solid, liquid or gas form. In some embodiments, the composition is in solid form.

[0066] Nonlimiting examples of decomposition reactions of a solid composition that generate a gaseous oxidizing agent include:

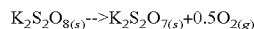
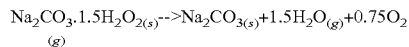
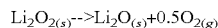
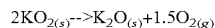
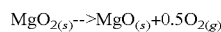
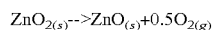
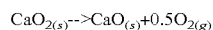

[0067] A nonlimiting example of a catalytic reaction (catalyst=MnO_{2(s)}) includes the following:

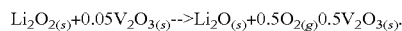
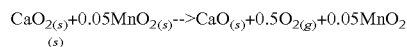

[0068] An example of selecting a composition A that decomposes into an oxidizing agent species C was illustrated with zinc peroxide. Thermogravimetric analysis (TGA) was performed on zinc peroxide by heating zinc peroxide at a rate of 10 C/min under nitrogen (25 mL/min) in a TA 5500 Thermogravimetric Analyzer. The data showed that the sample decomposed at 200° C. Thermal Desorption-Mass Spectroscopy (TD-MS) of the samples heated in helium flow at 10 C/min. showed the sample of zinc peroxide decomposed to give the desired oxygen as the major component together with some amounts of water and traces of carbon dioxide. Data was also generated to show the rate of weight loss of ZnO₂ when heated at 100° C., 120° C. and 140° C. as well as oxygen release from zinc peroxide when heated at 130° C. To help actively control the release of oxygen into a hard disk drive interior gas space, zinc peroxide could be disposed inside a disk drive with a heater since it decomposes at a temperature above typical operating temperatures of a hard disk drive.

[0069] In some embodiments, as illustrated by the equations 5-8 below, the chemical composition that generates an oxidizing agent species is a mixture of two or more chemical species F and G that react with each other to generate the oxidizing agent species C.



[0070] where F and G are reactants that when reacting with each other generate an oxidizing agent species C in the electronic device (e.g., hard disk drive), B is a byproduct of the reaction, C is an oxidizing agent species, D is a secondary product of reaction, and E is either a catalyst a stabilizer or a barrier. As mentioned above, F and G can each independently be in the form of a solid, liquid or gas state. In some embodiments, the chemical composition F that generates an oxidizing agent species C reacts with a gaseous or liquid species G to produce an oxidizing agent species C. Depending on the conditions (e.g., temperature and pressure) within the interior of an electronic device (e.g., hard disk drive), B, C, and D can each independently be in the form of a solid, liquid, or gas.

[0071] F and G can each be selected to provide a desirable rate of reaction and generate a desirable concentration of the gaseous oxidizing agent component. In some embodiments, at least one reactant comprises at least one peroxide. In some embodiments, a first reactant is chosen from calcium peroxide, lithium peroxide, sodium peroxide, potassium peroxide, sodium chlorate and mixtures thereof. In some embodiments, a second reactant is chosen from liquid water, gaseous water, gaseous carbon dioxide, solid iron and mixtures thereof. Nonlimiting examples of reactive systems are illustrated as follows:

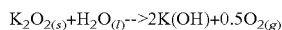
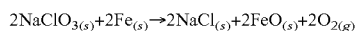
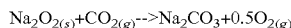
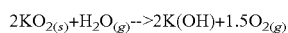
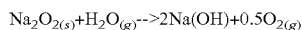
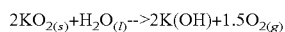
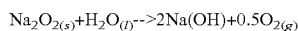
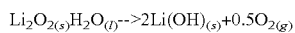
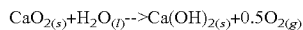
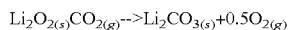
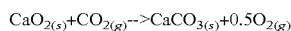

[0072] In some embodiments, as similarly described above with respect to the decomposition of A, one or more of the following can be used in combination with the selection of F and G: 1) a catalyst to accelerate the reaction of F and G, 2) a stabilizer to slow down the reaction of F and G, and/or 3) a barrier film or material, to control the rate the diffusion oxidizing agent species C. For example, the rate of such reactions systems may be altered from those of pure compounds by the addition of catalyst materials, stabilizers and/or barrier films/materials to maintain the desired oxygen partial pressure inside the drive. Possible catalysts include but are not limited to transition metal oxides and compounds, manganese oxides, manganese compounds, potas-

sium permanganate, copper oxides, copper compounds, nickel oxides, vanadium oxides, vanadium compounds, iron oxides, iron compounds, arsenic compounds, lead oxides, lead compounds, tin oxides and tin compounds.

[0073] In some embodiments a second chemical reaction with desired kinetics is used to produce in situ the reactant F. A non-limiting example of the in situ generation of the reactant F follows: Sodium or potassium hydrogen carbonate is decomposed to produce water and carbon dioxide; the nascent water and carbon dioxide react then in situ with potassium superoxide or lithium peroxide (shown below) to generate oxygen at the desired rate.

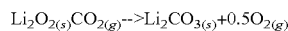
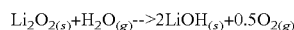
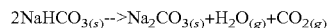

[0074] Some chemical species may exist in multiple forms for example water may exist and react in either the liquid form and/or the gas form, depending on the temperature.

[0075] In some embodiments, the active oxygen generating device comprises a reservoir containing water, an ultramicro-pump capable of dispensing 0.01-10 microliter of water per pulse to a container with a reactive oxygen generating compound. Illustrative reactive oxygen generating compounds include potassium superoxide, potassium peroxide, sodium peroxide and lithium peroxide. An optional catalyst may be added to the oxygen generating compound in concertation of 0.1-10% wt., e.g., from 1-5% wt. Illustrative catalysts include metal oxides such as potassium permanganate, manganese oxide, cobalt oxide, copper oxide, iron oxide, vanadium oxide and combinations thereof. Illustrative reactions are as follows:

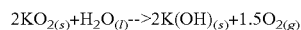
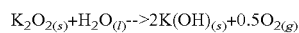
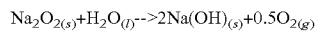
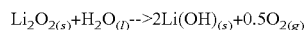

[0076] In some embodiments, an electronic device according to the present disclosure can include a generating device configured to actively decompose the composition or to cause two or more reactants to react to generate the gaseous oxidizing agent component.

[0077] Non-limiting examples of active oxygen production techniques include 1) a heater to accelerate the reaction rates of oxygen liberating compounds; 2) electrochemical cell to use voltage and electric current to stimulate oxidation/reduction reactions to produce oxygen; and 3) a device that dispenses water in a metered manner to a reactive oxygen generation compound.

[0078] FIGS. 1A and 1B show a schematic representation of active devices configured to actively decompose a composition using thermal energy to generate a gaseous oxidizing agent component.

[0079] FIG. 1A shows a basic embodiment of a device 100 that includes at least one heater 110 in thermal contact with a solid composition 105. The solid composition can be any solid composition selected to decompose when heated to a given temperature as described herein to decompose the composition and generate the gaseous oxidizing agent component.

[0080] A device such as **100** can include one or more additional components such as a temperature sensing device, power source, insulation, a container or barrier materials (e.g., metal foil) to contain the components (e.g., heater) and the composition, and a membrane to allow oxygen and other gasses to escape. A thermocouple or any other temperature sensing device can be used for feedback control of temperature, which can be used for the predetermined kinetics to generate a gaseous oxidizing agent component. Also, a heater can be selected to be in electrical communication with control hardware of an electronic device so that it can operate in an on-off manner to heat the composition to generate a gaseous oxidizing agent component. A heater can be used to joule heat the oxygen generating composition. Depending on the temperature desired, heater power can be determined to provide a desirable rate of oxygen generation for a given application. It has been observed that there can be a cooling effect if a heater system is directly exposed to the interior of an electronic device such as a hard disk drive during drive operation as compared to if the heater system is enclosed in container such as an environmental control module (ECM) that is disposed inside the electronic device. Thus, there can be a power savings due to the insulating effect of the ECM, especially as the power increases. Also, it has been observed that 1% oxygen concentration and 10% oxygen concentration had relatively little impact on the temperature difference for a given power setting when the heater system was exposed to the interior of a hard disk drive.

[0081] In some embodiments, a heater includes a compound heater, which is a small furnace that includes a heater element, a temperature probe, a chamber to contain the oxygen liberating compounds. In some embodiments, a compound heater can include a gas permeable membrane to allow oxygen produced to transport to the main interior volume of the electronic device (e.g., HDD). A compound heater operates by injecting electric current into the heating element to raise the temperature of the oxygen liberating chemical compound to the range of temperatures needed to liberate oxygen at the desired rate.

[0082] An oxygen generation device was built with 500 mg of zinc peroxide powder similar to that shown in FIG. 1A with a thermocouple in contact with the powder, all of which was wrapped in aluminum foil. The device was placed inside a hard disk drive and powered to reach outer surface temperature of the generator of 100° C. or 120° C. for different lengths of time. The composition of the gas of the drive and a control drive with no device was measured with a residual gas analyzer. It was observed that the oxygen partial pressure increased in the sealed drives after powering the zinc peroxide heater versus the control. The oxygen content of two drives increased from 1% to 10% and 18%, respectively, after the zinc peroxide heater was powered for a different length of time while the oxygen of three control drives containing with no oxygen generator remains at initial fill of 1%.

[0083] FIG. 1B shows a cross-section schematic of another embodiment of a device for actively generating a gaseous oxidizing agent component. As shown in FIG. 1B, shows plates **105** of solid composition (e.g., oxide) surrounding a single heater **110**. Thermally conductive material **111** can separate adjacent plates **105** and heater **110** from adjacent plates **105**. A wide variety of thermally conductive material and thicknesses can be used to facilitate desirable

heat transfer. Nonlimiting examples of thermally conductive material includes metal and/or ceramic materials. For example, an oxide **105** can be cast on a flexible thin ceramic fabric **111** such as alumina and wrapped around the heater **110**. Relatively low heater power can activate plates **111** relatively close to the heater **110** while higher power can activate plates **111** that are further away from heater **110**.

[0084] In some embodiments an electrochemical cell can be employed to actively generate a gaseous oxidizing agent component.

[0085] In some embodiments the electrochemical cell chemistry is based on the chemistry of certain metal-air batteries which generate oxygen gas during the charging cycles by reducing an oxygen-rich chemical species such as metal oxide or peroxide at the air battery cathode. Metal-air batteries use atmospheric oxygen to react with various species to produce both electricity and metal oxide or peroxide compounds on the cell's cathode. Next during the re-charge cycle, electricity is pumped into the cell and the reverse chemical processes liberates oxygen from the cell's cathode (anode when run in recharging direction). According to the present disclosure, a metal-air battery chemistry charge cycle can be used to generate oxygen. In some embodiments, electricity can be used to generate oxygen over the course of a single "recharge" cycle that would last the entire service life (e.g., 5 years) of an electronic device such as a hard disk drive.

[0086] In some embodiments, an electrochemical cell can include at least a cathode; an anode; a liquid or solid electrolyte, chemical composition that generates oxygen; an oxygen permeable membrane; and a power source and an assembly or case.

[0087] An oxygen producing cell can optionally include a gas permeable membrane on the cathode to allow liberated oxygen to escape the electrochemical cell. The electrochemical cell can also be electrically connected to a printed circuit board assembly (PCBA) of a hard disk drive to provide the appropriate current/voltage characteristics to control the oxygen production rate.

[0088] The particular chemistry could include oxygen generation from many potential metal oxides and peroxides. In some embodiments, oxygen generating electrochemical cells include potassium/air cells, sodium/air cells, lithium/air cells, zinc/air cells, magnesium/air cells, calcium/air cells, aluminum/air cells, iron/air cells, silicon/air cells and combinations thereof.

[0089] Below are examples of lithium based reactions:

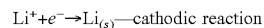
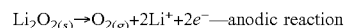

[0090] FIG. 2 shows a schematic representation of a metal-air battery that can be used in an electronic device according to the present disclosure to actively generate a gaseous oxidizing agent component. As shown, a metal air battery **200** includes a dc power source **201**, an electrolyte (Li+) **202**, a counter electrode with oxygen generating compound **203**, a metal electrode **204** and an oxygen permeable membrane **205**.

[0091] In some embodiments, a container can be disposed within an electronic device, where the container contains a composition that can be actively controlled to generate a gaseous oxidizing agent component. Optionally, the container can be initially filled with a gaseous oxidizing agent component. A container according to the present disclosure

can be configured to allow gaseous oxidizing agent component to transfer from inside the container to the interior gas space of the housing to maintain the gaseous oxidizing agent component at a mole fraction as described herein above. Selecting a container and any related components can depend whether the container is initially filled with a gaseous oxidizing agent component and/or the type and amount of composition that can generate a gaseous oxidizing agent component. Selecting a container can also depend on how it is incorporated into an electronic device (e.g., HDD) to release gaseous oxidizing agent into the interior space of the electronic device. For example, whether the container is configured to passively and/or actively allow gaseous oxidizing agent component to be controllably transferred from inside the container to the interior gas space of the housing.

[0092] A container that contains a composition that can be actively controlled to generate a gaseous oxidizing agent component (and that is optionally initially filled with a gaseous oxidizing agent component) may have any desired shape including a sphere, cylinder, cone, prism, cube, pyramid or rectangular prism, and combination thereof. Furthermore, the container could be a single container or multiple separate containers.

[0093] In some embodiments, a container is disposed within an environmental control module. In other embodiments, the container is an environmental control module.

The composition that can generate a gaseous oxidizing agent component can be contained in a container in such a way that generation of oxygen gas would be actively controlled and passed through a permeable membrane to the internal hard disk drive interior volume, while containing the bulk solid materials (e.g., granules, pellets, and the like) within the container.

[0094] In some embodiments, at least a portion of the container is permeable to one or more oxidizing agents such as molecular oxygen. For example, a container can include a membrane that is permeable to the gaseous oxidizing agent component and permits the gaseous oxidizing agent component to transfer from inside the container to the interior gas space of the housing. Oxygen permeable materials for use with or as a container according to the present disclosure include polymers, plastics, rubbers, elastomers, organic coatings, thin glass, and thin ceramics. In some embodiments, such materials have oxygen permeability coefficients between 0.0001 and 1000 (mL mm)/(m² d atm), e.g., oxygen permeability coefficients between 0.01 and 100 (mL mm)/(m² d atm). In some detail, illustrative permeable polymers include low density polyethylene (LDPE), high density polyethylene (HDPE), polypropylene (PP), polyvinylidene fluoride (PVDF), polyvinyl alcohol, ethylene vinyl alcohol, nylon, polycarbonate, polyimide, and combinations thereof. Oxygen permeable membranes include single or multilayer films. In some embodiments, an oxygen permeable membrane can have a thickness from greater than 0 to 500 mils, from 1 to 100 mils, or even from 2 to 30 mils. In some embodiments, oxygen permeable materials have permeation coefficients that increase with temperature. In some embodiments, a portion of the container can be made of an oxygen impermeable material and portion of the container is made of oxygen permeable material. For example, a portion of the container can be made of an oxygen impermeable material such as metal or glass and sealed by a lid made of an oxygen permeable membrane that is fastened to the container in any desirable manner (e.g. via glue).

[0095] In some embodiments, an entire container is made of an oxygen permeable membrane. For example, such a container can be a pouch that is sealed after the composition that can generate a gaseous oxidizing agent component is placed in the pouch or the container can be a vial with a threaded lid that is fastened to the container.

[0096] In some embodiments, a container may optionally contain other materials such as absorbents that capture secondary degradation products. For example, water absorbing material can be included to absorb water generated from the oxygen producing reaction. Such water can, e.g., accelerate the oxygen producing reaction and/or cause the pressure in the container to increase to an undue degree.

[0097] In some embodiments, a container can include a valve that can be actuated from a closed position to an open position to allow gaseous oxidizing agent component to flow from inside the container to the interior gas space of the housing.

[0098] FIG. 3 shows a non-limiting example of a dual chamber container 300 with a permeation layer and microvalve, which works like a 2-stage regulator.

[0099] Container 300 includes a composition 304 that generates a gaseous oxidizing agent component. Alternatively, the container can be filled (and pressurized) with a gaseous oxidizing agent component (e.g., up to a pressure of 5-10 atm or more) to permit controlled release of oxidizing agent component from container to the interior space of an electronic device (e.g., HDD) to provide oxidizing agent component in amount that maintains the concentration of the oxidizing agent component within a desired range over a desired time period.

[0100] As shown, the composition 304 is disposed in a relatively large chamber 303, where chamber 303 functions as an oxygen reservoir. Chamber 301 is a relatively small chamber compared to chamber 303 and functions to define a release volume. Chamber 301 is separated from chamber 303 via an oxygen permeable membrane 302 selected to equilibrate chambers 303 and 301 in about 1 minute to 30 days, and more preferably in 1 day to 15 days. A nonlimiting example of membrane 302 includes polyethylene. As shown, a grid 310 is positioned between membrane 302 and cap 305 to help avoid undue plastic deformation of 302 at temperature of about 60° C. Cap 305 can be fastened to housing 308 via welding or bonding (e.g., gluing with an adhesive). As shown, cap 305 is coupled to housing 308 along an interlocking bond line. Cap 305 also includes an electro-mechanical microvalve 315 (e.g., piezoelectric or bimetallic) that can be controllably actuated (e.g., electrically activated) from a closed position to an open position for release of oxygen from container 300.

[0101] Container 300 is small enough to fit within the cavity of an electronic device such as a hard disk drive or even inside and environmental control module. Container 300 can be constructed of non-elastic hard housing 308, which can help keep the interior of an electronic device clean.

[0102] As mentioned, container 300 functions like a two-stage regulator to equalize pressure from large chamber 303 to small chamber 301 like a tiny scuba tank (in a time period of hours or days). In some embodiments, oxygen can be released from small chamber 301 into the interior of an electronic device every 4-6 weeks. For example, about 1 cubic centimeter per week of oxygen can transfer from chamber 303 to chamber 301. Oxygen can be released from

chamber 301 via valve 315 relatively fast. The valve leak rate can be selected to be as low as desired (e.g., about 0.1 cubic centimeter or less per month).

[0103] In some embodiments, the oxygen generating chemical composition described above and optionally including one or more of a heater, probes, sensors, components of the electrochemical cell and/or other mechanical or electrical components can be packaged into an assembly. The assembly can be packaged in such a way to avoid corrosion of the drive components while maintaining gas exchange with the drive and/or to avoid the introduction of particulate or chemical contamination into the internal gas space of the electronic device.

[0104] FIGS. 4A-4D illustrate one non-limiting embodiment according to the present disclosure of including a composition that can generate a gaseous oxidizing agent component into a hard disk drive.

[0105] FIG. 4A shows a synoptic view of an Environmental Control Module (ECM) 410 according to the present disclosure that is installed in a hard disk drive (HDD) 400 with the top cover removed.

[0106] The ECM 410 is referred to as an “expanded” ECM because the ECM has been modified to accommodate a composition 412 that can generate a gaseous oxidizing agent component. An ECM 410 can include an ECM body, a solid composition 412 that can generate a gaseous oxidizing agent component, a desiccant 413 for absorbing moisture, a membrane (e.g., expanded polytetrafluorethylene (ePTFE)) 416 that can contain solid particulate matter within ECM while being permeable to at least oxygen gas so that oxygen gas can transfer from the ECM 410 to the interior of HDD 400 and be consumed by one or more oxidizing reactions.

[0107] FIG. 4B is a partial view of HDD 400 with ECM 410 removed to show the vertical wall 450 of the PCC with flex connector.

[0108] FIG. 4C is another partial view of the expanded Environmental Control Module (ECM) 410 in the corner of the Hard Disk Drive (HDD) 400 between the Voice Coil Motor (VCM) 420 and the Ramp 436. The ECM 410 sits atop the Printed Circuit Connector (PCC) bulkhead (not visible). This expanded ECM 410 has internal volume suitable for containing either an active or passive oxygen generating system. The oxygen generator would be installed within the ECM. As shown in FIG. 4D, the oxygen generator is a solid composition 412 that passively generates a gaseous oxidizing agent component. In this embodiment, oxygen can be vented from the part 460 through an aperture covered by permeable membrane 416 shown on the top of the ECM.

[0109] The PCC bulkhead contains many electrical conduits to bring power to the VCM 420 and to allow passage of electrical signals between the recording heads and the HDD external environment. It could allow electrical power to be conducted to an active oxygen generator system in ECM 410.

[0110] FIG. 4D shows a cross-sectional view ECM 410. As shown, the black volume is the available internal volume for an oxygen generator 412 as well as desiccant 413 for HDD internal humidity control.

[0111] Alternatively, a container according to the present disclosure (e.g., vial, capsule, etc.) could be placed a wide variety of other locations within a HDD besides the ECM. For example, as shown in FIG. 4A, a container could be placed in a cavity such as cavity 470. A cavity such as cavity 470 may already be present in base 430 (e.g., to manage the

mass of cast in the corner area). As mentioned above, containers according to the present disclosure can contain a composition that generates a gaseous oxidizing agent component and/or that can be filled (and pressurized) with a gaseous oxidizing agent component.

[0112] FIG. 5 illustrates another non-limiting embodiment according to the present disclosure of including a composition that can generate a gaseous oxidizing agent component into a hard disk drive. As shown in FIG. 5, the base 510 of a HDD is shown with the top cover, ECM, and disk pack removed. The floor of base 510 may include a small well that is under the disk pack. The well can include an oxygen generation system such as an electrochemical cell to generate oxygen similar in a form similar to a watch battery. As shown, a permeable membrane 520 is on top of the cell for oxygen out-flux. Electrical leads at the bottom of the cell (not shown) can be potted into the base 510 for a gas-tight seal.

[0113] FIG. 6 illustrates another non-limiting embodiment according to the present disclosure of including a composition that can be actively controlled to generate a gaseous oxidizing agent component into a hard disk drive. As shown in FIG. 6, a thin-film electrochemical oxygen generator cell 610 attached to the back side of the vertical wall 650. An extension of the flex connector feeds the cell with electrical power. ECM removed for clarity.

[0114] FIGS. 7A-7N illustrate another non-limiting embodiment according to the present disclosure of including a composition that can be actively controlled to generate a gaseous oxidizing agent component in a hard disk drive.

[0115] FIG. 7A shows an isometric view of a hard disk drive (HDD) 700 with the oxygen generator ECM assembly 710 installed. The top cover of the HDD 700 is removed for illustration purposes. The ECM frame can anchor onto PCC Bulkhead (underneath the ECM) with pins. As discussed below, the ECM 710 contains desiccator 735 and a heater assembly 720 that includes a composition (e.g., zinc peroxide) that can generate a gaseous oxidizing agent component. Electrical power can be routed through the ECM frame from the PCC to the heater assembly 720. As discussed below, heater assembly 720 includes a helical heating coil and has a metallized, gas-tight seal to keep the composition (e.g., zinc peroxide) dry at least until use.

[0116] FIG. 7B shows a cross-sectional view of the HDD 700 through the ECM 710 and with a HDD top cover 705 installed.

[0117] FIG. 7C shows a close-up of the view in FIG. 7B. The ECM 710 includes an ECM outer frame 711 and an inner wall 712 to separate the desiccator module 730 from the heater module 720. The inner wall 712 can help insulate the desiccator module 730 from the heater module 720 so that the desiccator module 730 is not heated to an undue degree, thereby causing moisture to transfer out of the desiccant 735. The ECM 710 is held in place vertically with the assistance of the top cover 705 gasket bead 750. The ECM 710 also includes a circular inlet diffuser filter 760 that aligns with a helium fill hole and filters incoming gas.

[0118] As shown, the desiccator module 730 is a discrete unit that can slip fits into ECM frame 711 and inner wall 712. Alternatively, desiccator module 730 could be an integral with the ECM frame 711. As mentioned, desiccator module 730 contains desiccant for relative humidity (RH) control. Desiccator module 730 can also contain activated carbons for volatile organic compound (VOC) control.

[0119] As shown in FIGS. 7H and 7O, heater module 720 is in the form of a hollow cylinder having an outer wall 727 and an interior space 726 containing a helical heater coil 725. A composition that can generate a gaseous oxidizing agent component (e.g., zinc peroxide) can be loaded into the interior space 726 so that the composition can be thermally heated as desired.

[0120] FIG. 7D shows an isometric top view of the whole oxygen generator ECM assembly 710.

[0121] FIG. 7E shows an isometric bottom view of the whole oxygen generator ECM assembly 710 illustrating electrical contacts 765, which can mate with corresponding ones on the PCC bulkhead.

[0122] FIG. 7F shows another isometric bottom view of the whole oxygen generator ECM assembly 710 illustrating electrical contacts 765, which can mate with corresponding ones on the PCC bulkhead.

[0123] FIG. 7G shows a cross-sectional view of the whole oxygen generator ECM assembly 710.

[0124] FIG. 7H shows an exploded view of the whole oxygen generator ECM assembly 710 including electrical contacts 766 on heater module 720.

[0125] FIG. 7I shows an isometric top view of the ECM frame 711 that will hold both the desiccator module 730 and the oxygen generator module 720. It will reside in the HDD atop the PCC bulkhead. The structure 767 is a flex circuit to conduct electrical power to the oxygen generator 720.

[0126] FIG. 7J is an isometric view of the top of the desiccator module 730. As shown, it is a gas-tight box with a soft aluminum seal that hold the desiccant. The seal keeps the desiccant dry on the manufacturing floor. The desiccator is activated by breaking the seal 761.

[0127] FIG. 7K is an isometric view of the bottom of the desiccator module 730. FIG. 7L is an isometric view of one end of the heater module 720. A breather membrane (e.g., polytetrafluorethylene (PTFE)) 721 is shown on one end of the module 720 to allow diffusion of oxygen and other gasses.

[0128] FIG. 7M is an isometric view of the other end of the heater module 720 having the electrical contacts 766.

[0129] FIG. 7N is a cross-sectional view of the heater module 720, which is considered a high aspect ratio oxygen generator module. The housing provides thermal insulation. Additional thermal insulation can optionally added around the generator housing to reduce power consumption. The coil 725 of heating wire can be surrounded by an oxygen generating solid such as zinc peroxide. On the left are electrical button contacts 766 to power the coil 725. On the right is a PTFE membrane 721 to let oxygen escape while containing particle contamination.

[0130] In some embodiments, a heater module can include a heating element from a dispersed phase of electrically conducting material, which can help provide desirable temperature uniformity to the oxygen generating composition. Non-limiting examples of such electrically conducting material includes wire wool and metal foam. The oxygen generating material (e.g., zinc peroxide) can be present in the interstices. This way, the oxygen generating material can be in close proximity to the heating surface, thereby facilitating relatively uniform oxygen production and release. The density and structure of the electrically conducting material can be provided such that there is a continuous electrical conduction path through the heater module. For example, a hollow housing similar to module 2720 could be packed

with a dispersed phase of electrically conducting material and a composition that can generate a gaseous oxidizing agent component within its interstices. Electrical terminals could be present so that electrical current could be passed through the housing/module thereby heating the composition as desired.

[0131] Active oxygen production additionally allows for the option of providing an input measurement of oxygen concentration to determine how much oxygen production is needed to maintain the desired oxygen concentration. This input measurement could be provided by a sensor that detects the concentration of the gaseous oxidizing agent component in the interior gas space (e.g., a pressure sensor or oxygen molarity sensor within an electronic device such as a HDD). In some embodiments, an electronic device includes a) a sensor that measures the concentration of the gaseous oxidizing agent component in the interior gas space; and b) a controller in electrical communication with the sensor and the generating device. The controller provides instructions to the generating device based on the measured concentration of the gaseous oxidizing agent component in the interior gas space to control the concentration of the gaseous oxidizing agent component in the interior gas space. In some embodiments, a method of generating a gaseous oxidizing agent component in an electronic device includes a) measuring the concentration of gaseous oxidizing agent component in an interior gas space of an electronic device; b) comparing the measured concentration of gaseous oxidizing agent component to a predetermined range of concentration of gaseous oxidizing agent component; and if the concentration is below the predetermined range then c) actively generating gaseous oxidizing agent component within the interior gas space of the electronic device if the measured concentration is below a predetermined value of concentration of gaseous oxidizing agent component. If the concentration is above the predetermined range then do nothing. After a predetermined period of time has passed, the process can be repeated.

[0132] It is noted that monitoring at a given time interval for one set of conditions can produce different results if one or more conditions change. For example, if the oxygen consumption occurs at a slower rate for a given time interval, then the oxygen concentration may be within acceptable limits when monitored, but fall outside acceptable limits shortly after being monitored, thereby causing the oxygen concentration to become unacceptably low before the next monitoring begins. According to the present disclosure, a secondary check feedback (from a sensor such as pressure, temperature and/or relative humidity besides oxygen concentration measurement) can be used for feedback control. If desired, the time interval for monitoring can be adjusted accordingly as well.

What is claimed is:

1. An electronic device comprising:

- a) a housing having an interior gas space;
- b) one or more electronic components disposed within the housing;
- c) a composition that can actively generate a gaseous oxidizing agent component, wherein the composition comprises a stabilizer that can slow down the generation of the gaseous oxidizing agent; and
- d) a generating device configured to actively cause the composition to generate the gaseous oxidizing agent component.

2. The electronic device of claim 1, wherein the stabilizer comprises water.

3. The electronic device of claim 2, wherein the composition comprises a compound chosen from calcium peroxide, magnesium peroxide, barium peroxide, zinc peroxide, cadmium peroxide, strontium peroxide, lithium peroxide, sodium peroxide, potassium peroxide, lithium nickel peroxide, potassium superoxide, sodium percarbonate, potassium percarbonate, calcium percarbonate, magnesium percarbonate, sodium perborate, potassium perborate, calcium perborate, magnesium perborate, potassium permanganate, sodium persulfate, potassium persulfate, and other peroxyhydrate salts such as potassium pyrophosphate peroxyhydrates and sodium sulfate-hydrogen peroxide-sodium chloride adduct, and mixtures thereof.

4. The electronic device of claim 2, wherein the composition comprises at least zinc peroxide or silver oxide.

5. An electronic device comprising:

- a) a housing having an interior gas space;
- b) one or more electronic components disposed within the housing;
- c) a composition that can actively generate a gaseous oxidizing agent component, wherein the composition comprises at least two reactants that react with each other to generate gaseous oxidizing agent component, and wherein a barrier is positioned between the at least two reactants to slow down the generation of the gaseous oxidizing agent; and
- d) a generating device configured to actively cause the composition to generate the gaseous oxidizing agent component.

6. An electronic device comprising:

- a) a housing having an interior gas space;
- b) one or more electronic components disposed within the housing;
- c) a composition that can actively generate a gaseous oxidizing agent component;
- d) a generating device configured to actively cause the composition to generate the gaseous oxidizing agent component; and
- e) a container disposed within the electronic device, wherein the composition that can generate a gaseous oxidizing agent component is disposed within the container, wherein the container is configured to allow gaseous oxidizing agent component to transfer from inside the container to the interior gas space of the housing, wherein the container is configured to passively and/or actively allow gaseous oxidizing agent component to be controllably transferred from inside the container to the interior gas space of the housing.

7. The electronic device of claim 6, wherein the container comprises a membrane that is permeable to gaseous oxidizing agent component and permits gaseous oxidizing agent component to transfer from inside the container to the interior gas space of the housing.

8. The electronic device of claim 7, wherein the gaseous oxidizing agent component comprises molecular oxygen and the membrane is permeable to molecular oxygen, and wherein the membrane comprises polymer chosen from low density polyethylene (LDPE), high density polyethylene (HDPE), polypropylene (PP), polyvinylidene fluoride (PVDF), polyvinyl alcohol, ethylene vinyl alcohol, nylon, polycarbonate, polyimide, and combinations thereof.

9. The electronic device of claim 7, wherein the gaseous oxidizing agent component comprises molecular oxygen and the membrane is permeable to molecular oxygen, and wherein the membrane has a molecular oxygen permeation coefficient that increases with temperature.

10. The electronic device of claim 6, wherein the container comprises a valve that can be actuated from a closed position to an open position to allow gaseous oxidizing agent component to flow from inside the container to the interior gas space of the housing.

11. The electronic device of claim 6, wherein the container is disposed within an environmental control module or the container is an environmental control module.

12. An electronic device comprising:

- a) a housing having an interior gas space;
- b) one or more electronic components disposed within the housing;
- c) a composition that can actively generate a gaseous oxidizing agent component; and
- d) a generating device configured to actively cause the composition to generate the gaseous oxidizing agent component, wherein the generating device comprises one or more heating elements in thermal contact with the composition, wherein the one or more heating elements are in electrical communication with a power source that is configured to apply power to the one or more heating elements in an on/off manner according to a predetermined time interval to heat the composition to a temperature that causes the composition to decompose to generate the gaseous oxidizing agent component.

13. The electronic device of claim 12, wherein the one or more heating elements comprise a coil surrounded by the composition, or wherein the one or more heating elements are distributed within the composition.

14. The electronic device of claim 13, wherein the composition comprises at least zinc peroxide or silver oxide.

15. The electronic device of claim 12, wherein the one or more heating elements comprise a coil having a first end and a second end opposite the first end, wherein the coil comprises electrical power contacts located on the first end.

16. The electronic device of claim 12, wherein the generating device comprises an outer housing having thermal insulation.

17. An electronic device comprising:

- a) a housing having an interior gas space;
- b) one or more electronic components disposed within the housing;
- c) a composition that can generate a gaseous oxidizing agent component, wherein the composition is in a form chosen from powder, granules, pellets, and combinations thereof; and
- d) a generating device configured to actively cause the composition to generate the gaseous oxidizing agent component.

18. An electronic device comprising:

- a) a housing having an interior gas space;
- b) one or more electronic components disposed within the housing;
- c) a composition that can generate a gaseous oxidizing agent component; and
- d) a generating device configured to actively cause the composition to generate the gaseous oxidizing agent component, wherein the generating device comprises at

least one metal-air battery that is in electrical communication with a power source that is configured to apply power to the metal-air battery according to a predetermined time interval to recharge the metal-air battery to generate the gaseous oxidizing agent component.

19. The electronic device of claim **18**, wherein the metal-air battery comprises a liquid or solid electrolyte, wherein the metal-air battery is optionally disposed within an environmental control module, wherein the environmental control module optionally includes a gaseous oxidizing agent component permeable membrane to permit gaseous oxidizing agent component to pass from inside to outside of the environmental control module.

20. The electronic device of claim **18**, wherein the metal-air battery comprises a metal electrode comprising metal chosen from potassium, sodium, lithium, zinc, magnesium, calcium, aluminum, iron, and combinations thereof.

* * * * *