



US 20140354023A1

(19) **United States**

(12) **Patent Application Publication**
YAMADA et al.

(10) **Pub. No.: US 2014/0354023 A1**

(43) **Pub. Date: Dec. 4, 2014**

(54) **SEAT SLIDE APPARATUS FOR VEHICLE**

(52) **U.S. Cl.**

(71) Applicant: **Aisin Seiki Kabushiki Kaisha,**
Kariya-shi (JP)

CPC **B60N 2/0722** (2013.01); **B60N 2/0732**
(2013.01)

USPC **297/344.1**; 248/429

(72) Inventors: **Yukifumi YAMADA,** Toyota-shi (JP);
Naoki GOTO, Tokai-shi (JP)

(57) **ABSTRACT**

(73) Assignee: **AISIN SEIKI KABUSHIKI KAISHA,**
Kariya-shi (JP)

A seat slide apparatus for a vehicle includes an upper rail configured to support a seat at an upper portion of the upper rail, a lower rail supporting the upper rail in a manner that the upper rail and the lower rail are movable relative to each other, and a shaft member extended in a lengthwise direction of the upper rail, wherein the upper rail includes a pair of vertical wall portions extended in an upper/lower direction, the upper rail includes a bent portion connecting the vertical wall portions to each other and the shaft member is provided at an inner side of the bent portion, and the shaft member includes a threaded portion provided at each end thereof in an axial direction, the bent portion includes lengthwise-direction-end portions, and the threaded portions of the shaft member face the lengthwise-direction-end portions of the bent portion.

(21) Appl. No.: **14/284,582**

(22) Filed: **May 22, 2014**

(30) **Foreign Application Priority Data**

May 30, 2013 (JP) 2013-114698

Publication Classification

(51) **Int. Cl.**
B60N 2/07 (2006.01)

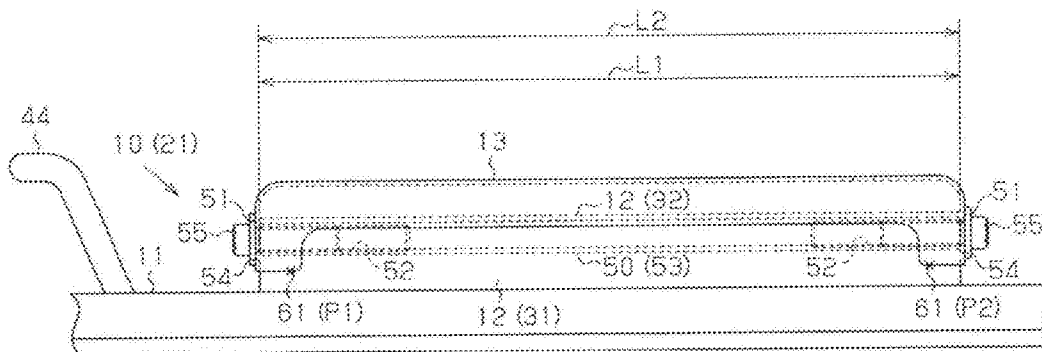

FIG. 1

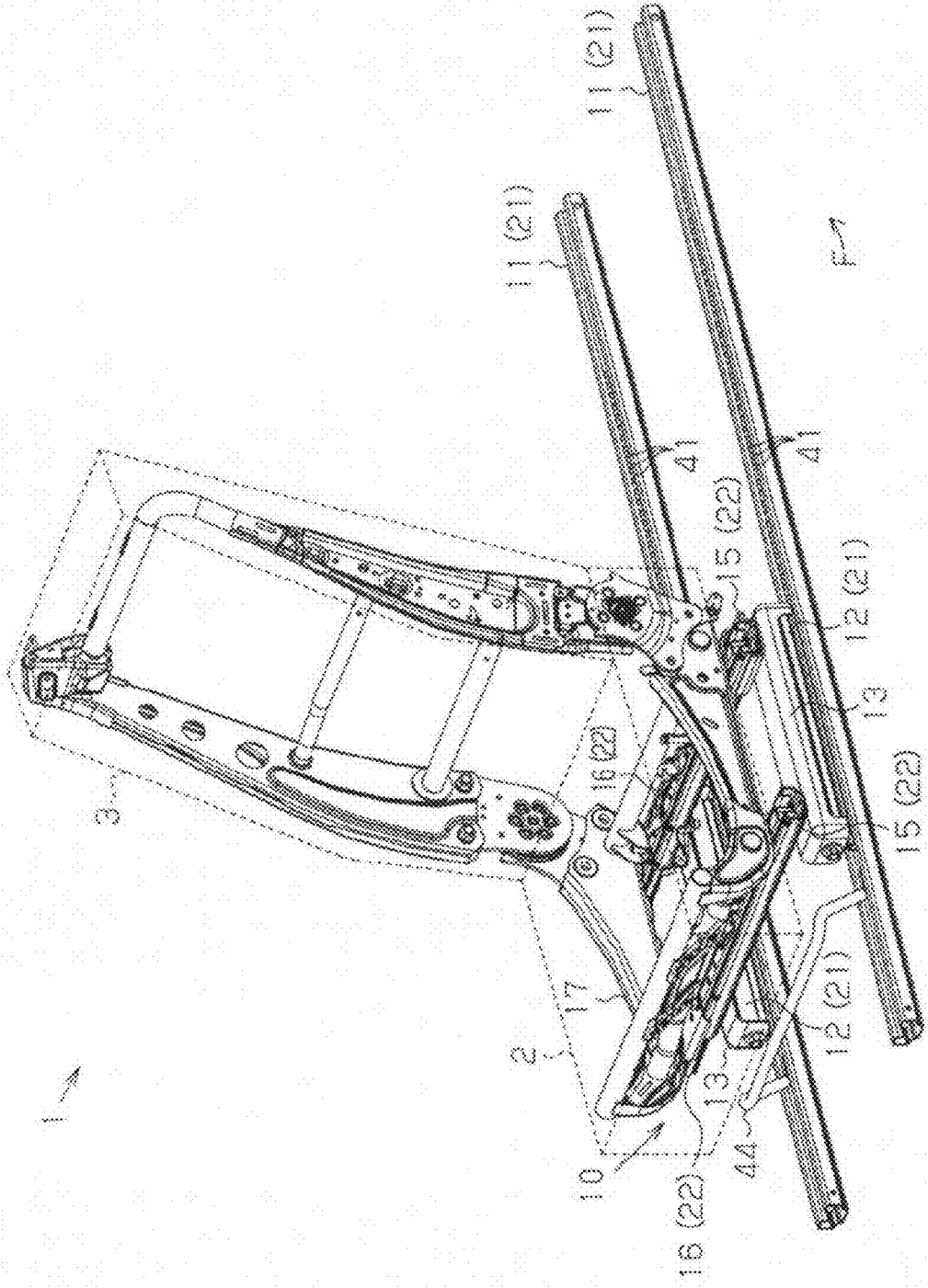

FIG. 2

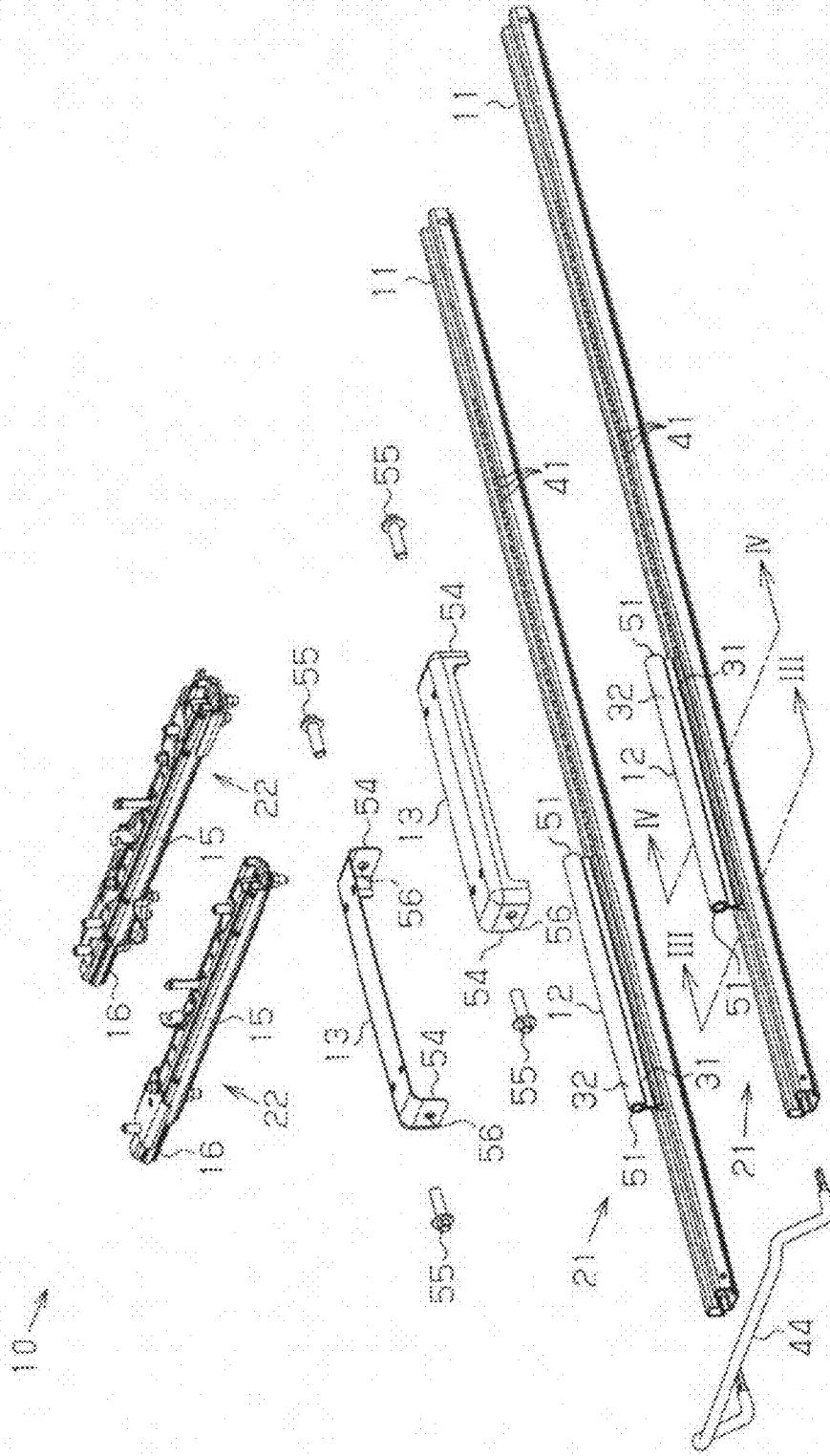

FIG. 3

10 (21)

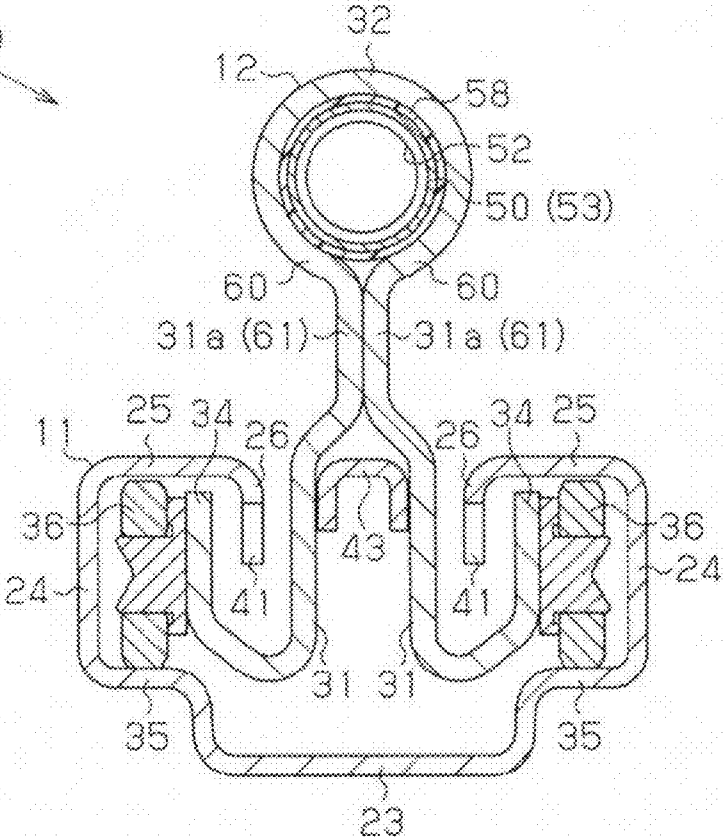

FIG. 4

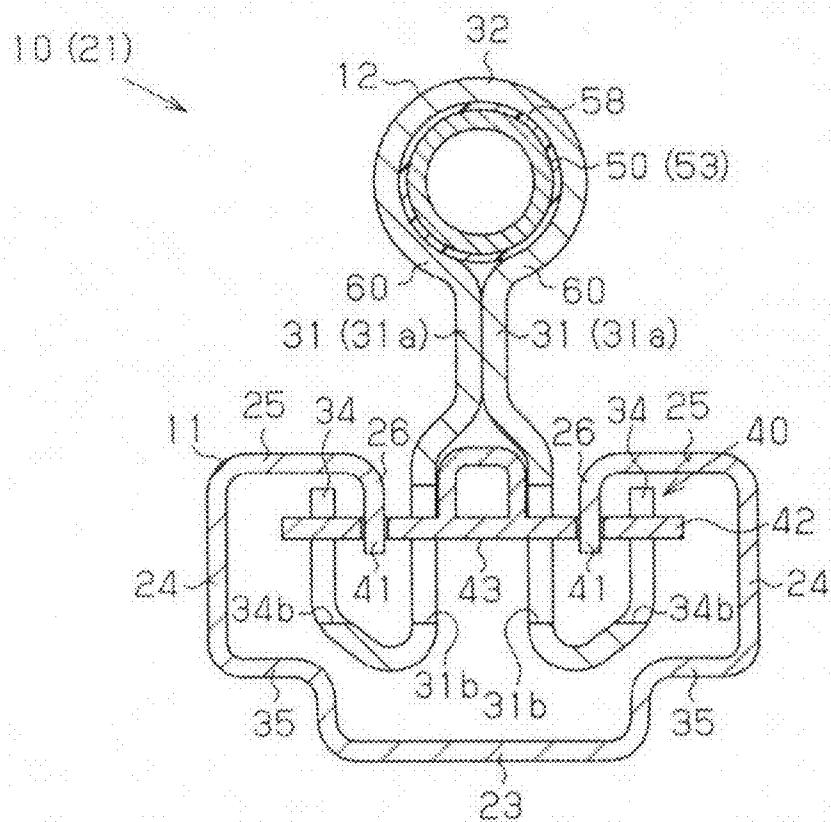

FIG. 5

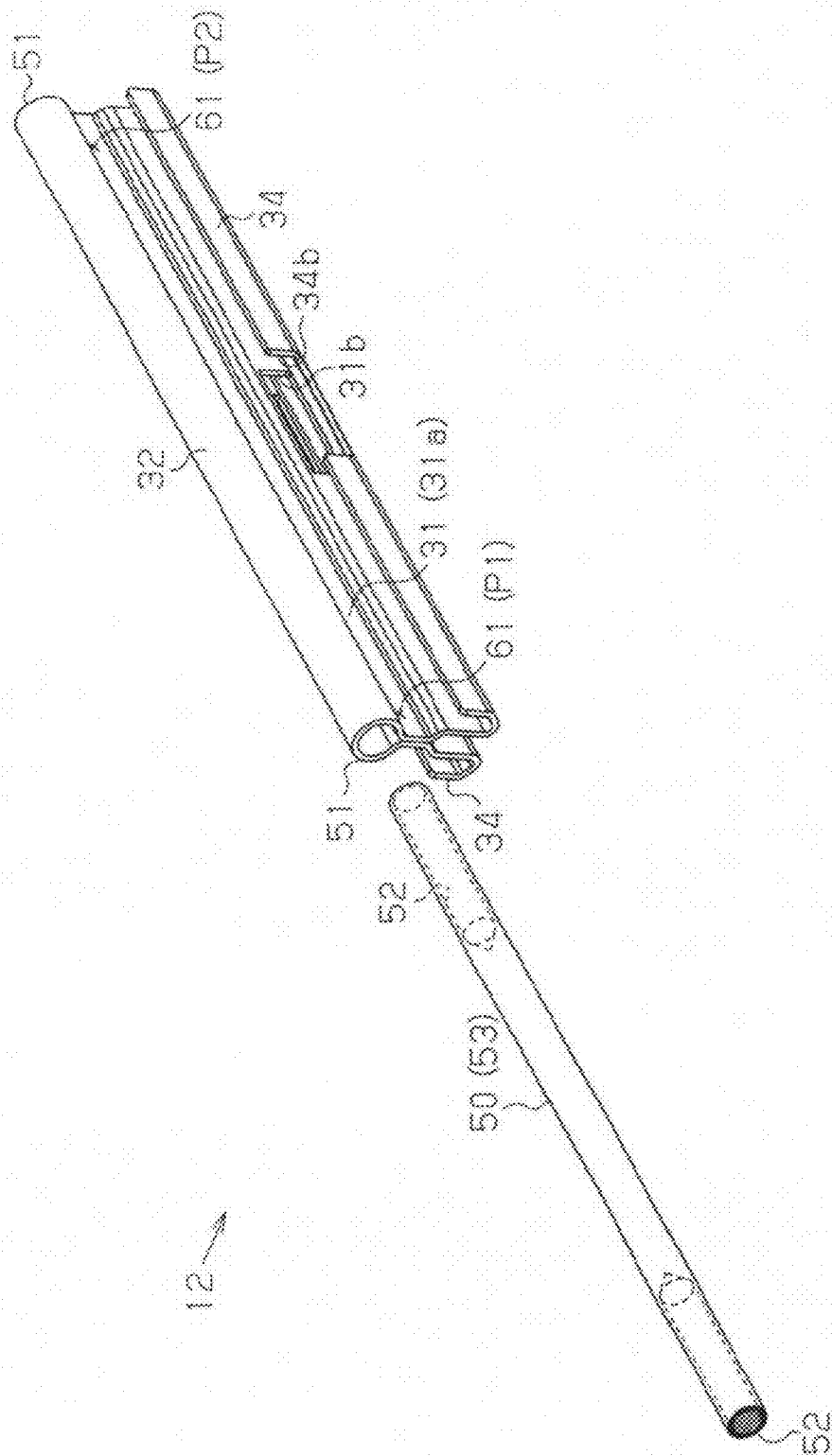

FIG. 6

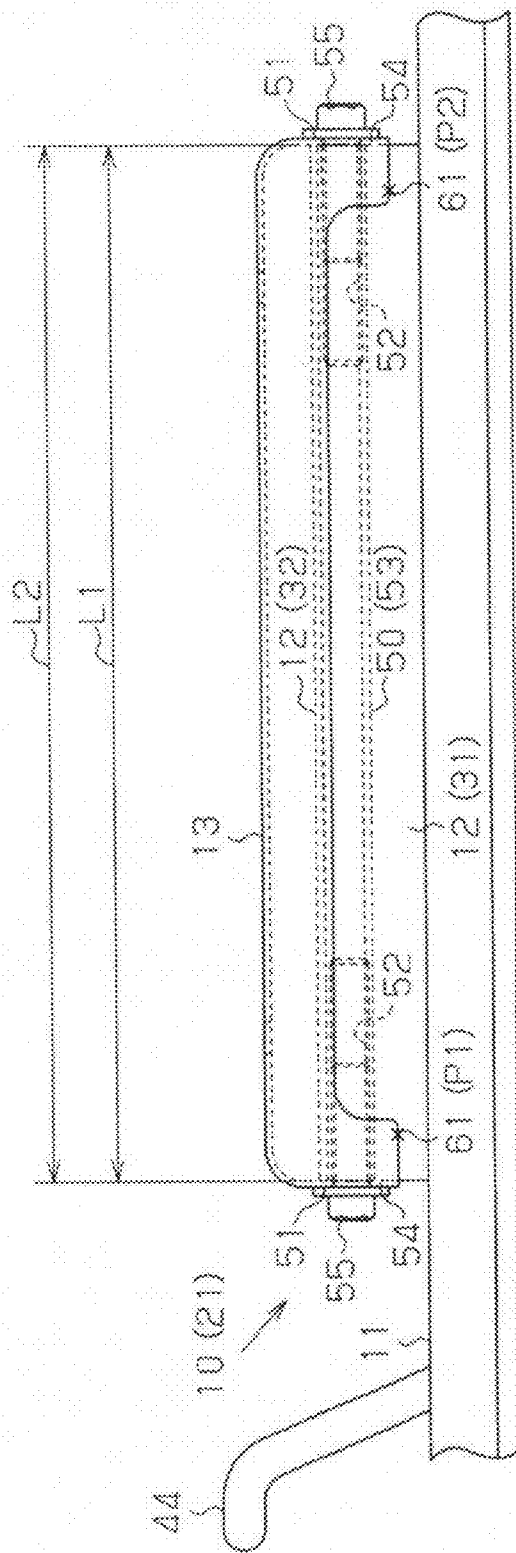

FIG. 7

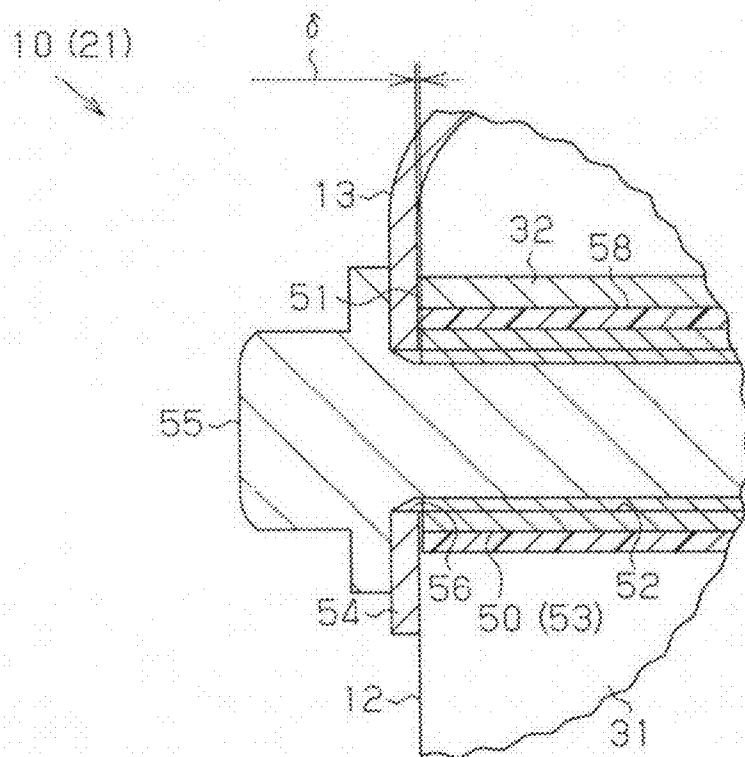

FIG. 8

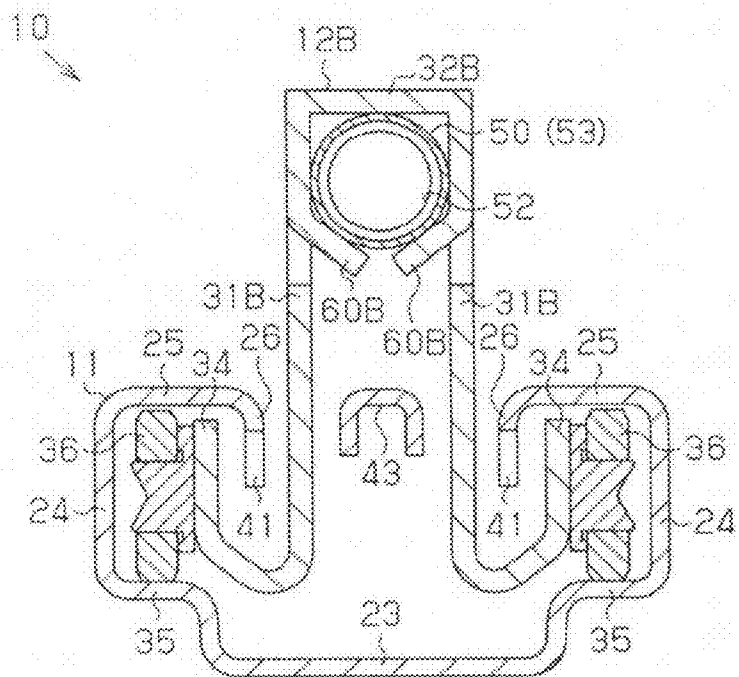

FIG. 9

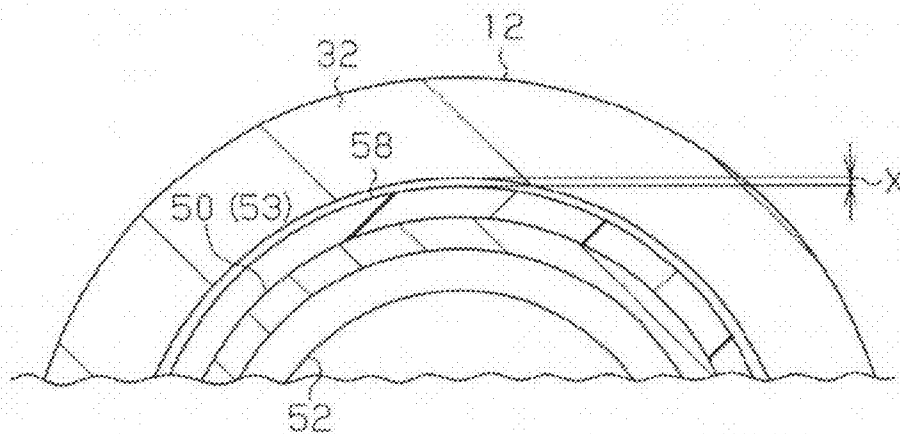
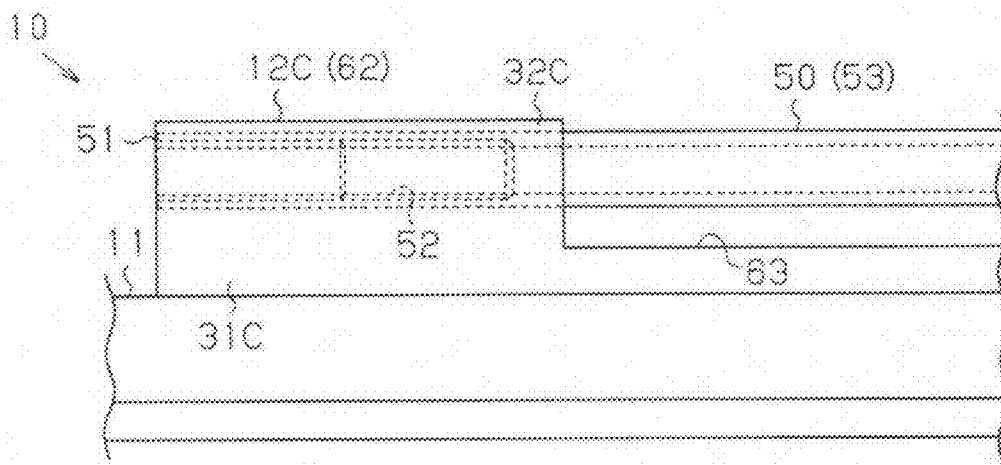

FIG. 10



SEAT SLIDE APPARATUS FOR VEHICLE

CROSS REFERENCE TO RELATED APPLICATIONS

[0001] This application is based on and claims priority under 35 U.S.C. §119 to Japanese Patent Application 2013-114698, filed on May 30, 2013, the entire content of which is incorporated herein by reference.

TECHNICAL FIELD

[0002] This disclosure generally relates to a seat slide apparatus for a vehicle.

BACKGROUND DISCUSSION

[0003] Usually, a seat slide apparatus for a vehicle includes an upper rail supporting a seat at an upper portion thereof and a lower rail supporting the upper rail in a state where the upper rail and the lower rail are movable relative to each other. In many cases, the upper rail is made from plate material which is bent or folded.

[0004] For example, according to a seat slide apparatus described in JP2004-90765A (which will be hereinafter referred to as Patent reference 1), an upper rail includes a pair of vertical wall portions facing each other and a bent portion connecting upper portions of the vertical wall portions to each other. A threaded portion used for fastening a seat is provided at each lengthwise-direction-end portion of the upper rail.

[0005] Further, JP2003-252087A (which will be hereinafter referred to as Patent reference 2) discloses a configuration where a reinforcement member formed in a plate shape is provided between vertical wall portions which constitute an upper rail. Thus, a support rigidity of the upper rail may be enhanced.

[0006] However, for example, at a vehicle collision, an extremely large load which is caused by an external force acting on the seat is applied to the upper rail. In order to avoid a deformation of the upper rail which is caused by such external force, the support rigidity of the upper rail is desired to be even more enhanced. Therefore, room for improvement remains in this regard.

[0007] A need thus exists for a seat slide apparatus for a vehicle, which is not susceptible to the drawback mentioned above.

SUMMARY

[0008] According to an aspect of this disclosure, a seat slide apparatus for a vehicle includes an upper rail configured to support a seat at an upper portion of the upper rail, a lower rail supporting the upper rail in a manner that the upper rail and the lower rail are movable relative to each other, and a shaft member extended in a lengthwise direction of the upper rail, wherein the upper rail includes a pair of vertical wall portions extended in an upper/lower direction, the upper rail includes a bent portion connecting the vertical wall portions to each other at upper portions of the vertical wall portions and the shaft member is provided at an inner side of the bent portion, and the shaft member includes a threaded portion provided at each end thereof in an axial direction, the bent portion opening in the axial direction of the shaft member includes lengthwise-direction-end portions, and the threaded portions of the shaft member face the lengthwise-direction-end portions of the bent portion.

[0009] According to another aspect of this disclosure, a seat apparatus for a vehicle including a seat slide apparatus for a vehicle including an upper rail configured to support a seat at an upper portion of the upper rail, a lower rail supporting the upper rail in a manner that the upper rail and the lower rail are movable relative to each other, and a shaft member extended in a lengthwise direction of the upper rail, wherein the upper rail includes a pair of vertical wall portions extended in an upper/lower direction, the upper rail includes a bent portion connecting the vertical wall portions to each other at upper portions of the vertical wall portions and the shaft member is provided at an inner side of the bent portion, the shaft member includes a threaded portion provided at each end thereof in an axial direction, the bent portion opening in the axial direction of the shaft member includes lengthwise-direction-end portions, and the threaded portions of the shaft member face the lengthwise-direction-end portions of the bent portion, the seat, a support member provided at the upper portion of the upper rail and supporting the seat, and a connection member threadedly attached to each of the threaded portions, and connecting the support member, the upper rail, and the shaft member to each other.

BRIEF DESCRIPTION OF THE DRAWINGS

[0010] The foregoing and additional features and characteristics of this disclosure will become more apparent from the following detailed description considered with the reference to the accompanying drawings, wherein:

[0011] FIG. 1 is a perspective view of a seat for a vehicle, which is supported by a seat slide apparatus of an embodiment disclosed here;

[0012] FIG. 2 is an exploded perspective view of the seat slide apparatus of the embodiment;

[0013] FIG. 3 is a cross-sectional view taken along line III-III in FIG. 2, which illustrates a first slide rail of the embodiment;

[0014] FIG. 4 is a cross-sectional view taken along line IV-IV in FIG. 2, which illustrates the first slide rail of the embodiment;

[0015] FIG. 5 is an exploded perspective view of an upper rail of the embodiment;

[0016] FIG. 6 is a side view of the first slide rail and a bracket fastened to the first slide rail according to the embodiment;

[0017] FIG. 7 is an enlarged cross-sectional view of a vicinity of a threaded portion provided at an end portion, in an axial direction, of a shaft member of the embodiment;

[0018] FIG. 8 is a cross-sectional view illustrating another example of the seat slide apparatus of the embodiment;

[0019] FIG. 9 is an enlarged cross-sectional view taken along line IV-IV of FIG. 2, which illustrates the seat slide apparatus of the embodiment; and

[0020] FIG. 10 is a side view illustrating another example of the seat slide apparatus of the embodiment.

DETAILED DESCRIPTION

[0021] An embodiment of a seat slide apparatus for a vehicle related to this disclosure will be explained with reference to the drawings. As illustrated in FIG. 1, a seat 1 for a vehicle includes a seat cushion 2 and a seat back 3 which is provided to be tiltable relative to a rear end portion of the seat cushion 2. The seat 1 is supported at a floor portion F of the vehicle via a seat slide apparatus 10.

[0022] Specifically, as illustrated in FIGS. 1 and 2, two lower rails 11 are provided at the floor portion F of the vehicle to extend in a front/rear direction of the vehicle. The lower rails 11 are arranged to be parallel to each other. An upper rail 12 is mounted on each of the lower rails 11 to be movable thereon. A bracket 13 is fastened to an upper portion of each of the upper rails 12.

[0023] A second lower rail 15 extending in a width direction of the vehicle is attached to a front end portion of each of the brackets 13 so as to span the brackets 13 across the width direction of the vehicle. Another second lower rail 15 extending in the width direction of the vehicle is attached to a rear end portion of each of the brackets 13 so as to span the brackets 13 across the width direction of the vehicle. A second upper rail 16 is attached to each of the second lower rails 15 to be movable on the second lower rail 15. In the present embodiment, a seat frame 17 (a side frame) is fastened to the second upper rails 16.

[0024] As described above, the seat slide apparatus 10 of the present embodiment includes first slide rails 21 and second slide rails 22 which are arranged in a shape of parallel crosses or a double-cross formation, that is, the first slide rails 21 and the second slide rails 22 are arranged to form a substantially rectangular shape. Thus, a seat position in the front/rear direction and the width direction of the vehicle is adjustable. The configurations of the first slide rails 21 are identical to each other, therefore the description will be made on one of the first slide rails 21. The configurations of the second slide rails 22 are identical to each other, therefore the description will be made on one of the second slide rails 22.

[0025] The first slide rails 21 allow a position of the seat 1 in the vehicle front/rear direction to be adjusted in a case where the upper rails 12 move on the lower rails 11. The second slide rails 22 allow a position of the seat 1 in the vehicle width direction to be adjusted in a case where the second upper rails 16 move on the second lower rails 15.

[0026] Next, configurations of the lower rails 11 and the upper rails 12 which constitute the first slide rails 21, and a configuration of a lock mechanism restricting a relative movement of the lower rails 11 and the upper rails 12 relative to each other will be described. In the present embodiment, each of the lower rails 11 and the upper rails 12, which constitute the first slide rail 21, is formed by performing a folding process on plate material.

[0027] Specifically, as illustrated in FIGS. 3 and 4, the lower rail 11 includes a bottom wall portion 23 arranged to extend in the vehicle front/rear direction (that is, the direction perpendicular to the paper surface on which each of FIGS. 3 and 4 is drawn). An outer wall portion 24 is provided in a standing condition at each end of the bottom wall portion 23 in a width direction thereof (that is, the right and left direction in each of FIGS. 3 and 4). Further, an upper wall portion 25 is provided at an upper end of each of the outer wall portions 24. Each of the upper wall portions 25 is formed in a flange shape that is folded back inwardly in the width direction. An inner wall portion 26 is provided at an end of each of the upper wall portions 25 to be folded back downwardly. Thus, the inner wall portions 26 are arranged to face each other in the width direction with a predetermined distance provided therebetween.

[0028] On the other hand, the upper rail 12 includes a pair of vertical wall portions 31 which are arranged between the inner wall portions 26 of the lower rail 11 to extend in an upper/lower direction. The upper/lower direction corre-

sponds to the upper/lower direction of the vehicle in a state where the seat slide apparatus 10 is mounted on the vehicle. The vertical wall portion 31 may correspond to a wall portion that is formed to be substantially vertical. The upper rail 12 includes a bent portion 32 arranged above the vertical wall portions 31 for connecting the vertical wall portions 31 to each other. In addition, the upper rail 12 includes folded-back portions 34 each of which is formed by folding a lower end of the corresponding vertical wall portion 31 upwardly. Thus, each of the folded-back portions 34 is arranged within a space portion surrounded by the corresponding outer wall portion 24, the upper wall portion 25 and the inner wall portion 26 of the lower rail 11. Plural wheels 36 are provided at each of the folded-back portions 34. The wheels 36 are in contact with track portions 35 provided at the bottom wall portion 23 of the lower rail 11 for rolling on the track portion 35. The track portion 35 is provided at each end of the bottom wall portion 23 in the width direction thereof.

[0029] That is, the upper rail 12 of the present embodiment moves on the lower rail 11 in a manner that the wheels 36 provided at the folded-back portions 34 roll, and thus the wheels 36 run on the track portions 35 with which the wheels 36 are in contact. In addition, the upper rail 12 is restricted from moving relative to the lower rail 11 in the upper direction and the width direction because the folded-back portions 34 of the upper rail 12 are surrounded by the outer wall portions 24, the upper wall portions 25 and the inner wall portions 26 of the lower rail 11. Accordingly, in the present embodiment, a positional relation of the lower rail 11 and the upper rail 12 is maintained stably.

[0030] As illustrated in FIG. 4, the seat slide apparatus 10 includes a lock mechanism 40 for restricting the relative movement of the lower rail 11 and the upper rail 12 relative to each other. Specifically, in the present embodiment, plural engagement tabs 41 are provided at each of the inner wall portions 26 of the lower rail 11 to protrude downwardly (refer to FIGS. 1 and 2). In the present embodiment, the engagement tabs 41 are arranged to be substantially equally spaced from one another to form a comb-teeth configuration. In addition, a lock member 43 including an engagement portion 42 is provided between the vertical wall portions 31 of the upper rail 12. A hole portion 31 b is formed at each of the vertical wall portions 31 and the engagement portion 42 is engageable with the corresponding engagement tabs 41 of the lower rail 11 via the hole portions 31 b. Further, according to the lock member 43, the engagement portion 42 moves upwardly and downwardly when an operation handle 44 provided at a front portion of the seat 1 is operated (refer to FIGS. 1 and 2). Each of the folded-back portions 34 includes a cut-out 34b which allows the engagement portion 42 to move upwardly and downwardly. Thus, the lock mechanism 40 of the present embodiment is configured to switch between a locked state where the relative movement between the lower rail 11 and the upper rail 12 is restricted and an unlocked state where the relative movement therebetween is allowed.

[0031] Specifically, according to the lock mechanism 40 of the present embodiment, when the operation handle 44 is not operated, the lock member 43 is biased by an elastic member and thus the engagement portion 42 is moved or displaced upwardly. Accordingly, the engagement portion 42 is engaged with the engagement tabs 41 of the lower rail 11, and thus the relative movement between the lower rail 11 and the upper rail 12 is restricted.

[0032] In addition, according to the lock mechanism 40 of the present embodiment, when the operation handle 44 is lifted upwardly, the lock member 43 moves downwardly. Accordingly, the engagement between the engagement portion 42 of the lock mechanism 40 and the engagement tabs 41 of the lower rail 11 is released, and thus the lower rail 11 and the upper rail 12 are allowed to move relative to each other.

[0033] Next, a support rigidity-enhancing structure of the upper rail 12 according to the present embodiment will be described.

[0034] As illustrated in FIGS. 3 to 6, in the present embodiment, each of the vertical wall portions 31 constituting the upper rail 12 includes an upper end portion 31a. The upper end portions 31a are connected to each other. In the present embodiment, by welding end portions of the upper end portions 31a in a lengthwise direction thereof (the right and left direction in FIG. 6, that is, a lengthwise direction of the upper rail 12), the upper end portions 31a are connected or joined to each other (welded points P1 and P2). The bent portion 32, which connects the vertical wall portions 31, is formed in a bag-shaped configuration including a substantially annular cross-sectional shape (a substantially annular shape of an end surface).

[0035] In the present embodiment, a shaft member 50 formed to extend in the lengthwise direction of the upper rail 12 is provided at an inner side of the bent portion 32. A threaded portion 52 is provided at each of axial ends of the shaft member 50. The threaded portions 52 face lengthwise-direction-end portions 51 of the bent portion 32 opening in the axial direction of the shaft member 50. As described above, the bracket 13, which supports the seat 1 (and the second slide rails 22) above the upper rail 12, is configured to be fastened to the upper rail 12 with the threaded portions 52.

[0036] Specifically, in the present embodiment, a pipe 53, which corresponds to a hollow pipe, is used for the shaft member 50 as illustrated in FIGS. 4 and 6. Each of the threaded portions 52 is formed by threading an internal thread at an inner periphery of the pipe 53.

[0037] As illustrated in FIGS. 2, 6 and 7, a flange portion 54 is provided at each lengthwise-direction-end portion of the bracket 13 to face the corresponding lengthwise-direction-end portion 51 of the bent portion 32 in the lengthwise direction of the upper rail 12. Further, an insertion hole 56, into which a bolt 55 serving as a fastening member or a connection member is inserted, is provided at each of the flange portions 54. Thus, the bracket 13 is fastened to the upper portion of the upper rail 12 with a fastening force of the bolts 55 that are threadedly attached to the threaded portions 52 of the shaft member 50 via the insertion holes 56.

[0038] More specifically, in the present embodiment, as illustrated in FIGS. 3 and 4, lower portions of the bent portion 32, which are curved around a lower portion of the shaft member 50, serve as receiving portions 60 that support the lower portion of the shaft member 50. A buffer material 58 which is made of, for example, rubber or soft resin, is interposed between the bent portion 32 and the shaft member 50. As illustrated in FIG. 6, the welded points P1 and P2, at which the upper end portions 31a of the vertical wall portions 31 are connected to each other as described above, are set at positions corresponding to the threaded portions 52. In the present embodiment, each of the welded points P1 and P2 serves as a tightened portion 61 which reduces a diameter of the annular

shape of the bent portion 32. Thus, the shaft member 50 is attached to (fitted to) the inner side of the bent portion 32 by pressure.

[0039] An axial length L1 of the shaft member 50 is slightly shorter than a length L2 of the bent portion 32 (that is, the length of the upper rail 12) ($L1 < L2$). That is, as illustrated in FIG. 7, the shaft member 50 of the present embodiment includes an elongation allowance δ for elongation caused by the fastening which is obtained by the threaded portions 52. Accordingly, in the present embodiment, positioning of the bracket 13 is performed easily and the bracket 13 is fastened to the upper rail 12 reliably.

[0040] Next, an operation of the seat slide apparatus including the above configuration will be described. In the present embodiment, the bracket 13 for supporting the seat 1 above the upper rail 12 is fastened to the upper portion of the upper rail 12 with use of the threaded portions 52 provided at the axial ends of the shaft member 50. That is, the upper rail 12 of the present embodiment includes the shaft member 50 arranged to extend in the lengthwise direction of the upper rail 12 and serving as a structural body, and supports a seat load. That is, the upper rail 12 includes the shaft member 50 as part of the upper rail 12. Thus, the support rigidity of the upper rail 12 is enhanced in the present embodiment.

[0041] According to the present embodiment, following effects are obtained.

[0042] (1) The upper rail 12 includes the pair of vertical wall portions 31 arranged to extend in the upper/lower direction and the bent portion 32 arranged at the upper portion of each of the vertical wall portions 31 for connecting the vertical wall portions 31 to each other. Further, the shaft member 50 formed to extend in the lengthwise direction of the upper rail 12 is provided within the bent portion 32. The threaded portion 52 is provided at each of the axial ends of the shaft member 50. The threaded portions 52, which face the lengthwise-direction-end portions 51 of the bent portion 32 opening in the axial direction of the shaft member 50, are provided at the axial ends of the shaft member 50.

[0043] According to the above-described configuration, the bolt 55 is threadedly attached to, that is, screwed in, each of the threaded portions 52 of the shaft member 50 via the lengthwise-direction-end portion 51 of the bent portion 32. Accordingly, the seat 1 (the bracket 13) is fastened to the upper portion of the upper rail 12 with the fastening force of the bolts 55. In addition, the shaft member 50 serves as the structural body, and thus the support rigidity of the upper rail 12 is enhanced along an entire length thereof. That is, because the seat load is received by the shaft member 50, deformation is not likely to occur to the vertical wall portions 31 or the bent portion 32 which are formed by the folding process. Particularly, a bending strength of the upper rail 12 in the lengthwise direction may be enhanced significantly. Thus, a smooth relative movement between the lower rail 11 and the upper rail 12, and a stable operation of the lock mechanism are assured, thereby ensuring a high reliability. In addition, at the shaft member 50, a tensile force which elongates or pulls out the shaft member 50 is generated by the fastening which is obtained by the threaded portion 52 provided at each of the axial ends of the shaft member 50. Thus, the fastened condition is maintained stably.

[0044] (2) The bent portion 32 of the upper rail 12 includes the annular shape and the shaft member 50 is fitted in the inner side of the annular shape. With such a configuration, the shaft member 50 is maintained at the inner side of the bent portion

32 easily and reliably with the simple configuration. Thus, the high support rigidity of the upper rail is assured.

[0045] (3) The lower portions of the bent portion **32**, which are curved around the lower portion of the shaft member **50** so as to surround the lower portion of the shaft member **50**, form the receiving portions **60** supporting the lower portion of the shaft member **50**. With such a configuration, the shaft member **50** is held at the inner side of the bent portion **32** against the seat load in a direction in which the shaft member **50** is pushed downwardly. Thus, the high support rigidity is assured.

[0046] (4) The upper rail **12** includes the tightened portions **61** (the welded points **P1** and **P2**) which connect the upper end portions **31a** of the vertical wall portions **31** to each other and thus reduce the diameter of the annular shape of the bent portion **32**. According to the above-described configuration, after the shaft member **50** is arranged at the inner side of the bent portion **32**, the diameter of the annular shape of the bent portion **32** is reduced so that the shaft member **50** is attached to the inner side of the bent portion **32** by pressure (that is, the shaft member **50** is fitted to the inner side of the bent portion **32**). Thus, the shaft member **50** is held at the inside of the bent portion **32** easily and reliably.

[0047] (5) The axial length **L1** of the shaft member **50** is slightly shorter than the length **L2** of the bent portion **32** ($L1 < L2$). That is, the elongation allowance δ for the elongation of the shaft member **50** which is caused by the fastening thereof is provided at the shaft member **50** in advance, and thus the positioning of the upper rail **12** and the member fastened to the upper rail **12** is performed easily. Thus, the fastening which uses the threaded portion **52** is reliably ensured.

[0048] (6) The buffer material **58** is arranged between the bent portion **32** of the upper rail **12** and the shaft member **50**. Thus, a resonance frequency of the seat **1** is lowered, or resonance amplitude of the seat **1** is reduced. As a result, a damping effect of the resonance is enhanced. Because the shaft member **50** that is pre-coated with the buffer material **58** is used, that is, the shaft member **50** is coated with the buffer material **58** in advance, the vibration-proof effects and the sound-proof effects are obtained easily at low costs.

[0049] (7) The pipe **53**, which is hollow, is used as the shaft member **50**. As a result, weight of the shaft member **50** is reduced while a high strength is maintained. In addition, because the internal threads are formed at the inner periphery of the axial end portions of the pipe **53** (the shaft member **50**), the threaded portions **52** are provided easily.

[0050] The aforementioned embodiment may be modified as follows. In the aforementioned embodiment, the seat **1** includes the first slide rails **21** and the second slide rails **22** which are arranged in the shape of the parallel crosses. The rigidity-enhancing structure of the upper rails **12**, which is achieved by the shaft member **50** including the threaded portions **52** provided at the end portions of the shaft member **50**, is applied to the first slide rails **21**. However, the application of the rigidity-enhancing structure is not limited thereto. The similar rigidity-enhancing structure may be applied to the second slide rails **22** that are provided above the first slide rails **21** via the brackets **13**. Alternatively, the similar rigidity-enhancing structure may be applied to the first slide rails **21** and the second slide rails **22**.

[0051] The second slide rails **22** may be omitted from the configuration of the present embodiment. That is, the seat frame **17** (for example, a side frame) may be fastened directly

to the shaft member **50** without interposing a supporting member including, for example, the bracket **13**.

[0052] In the aforementioned embodiment, the bent portion **32** of the upper rail **12** includes the bag-shaped configuration of which the cross-sectional shape (the shape of the end surface) is substantially annular. However, the cross-sectional shape of the bent portion **32** is not limited to the substantially annular. For example, in a case where the shaft member **50** is formed in a polygon shape, the bent portion **32** may include such a cross-sectional shape that allows the shaft member **50** to be fitted into the inner periphery of the bent portion **32**. In addition, a shape of the opening portion at the lengthwise-direction-end portion **51** of the bent portion **32** may be modified arbitrarily.

[0053] The bent portion **32** may include a configuration other than the bag-shaped configuration and may open downwardly. In that case, as illustrated in FIG. 8, an upper rail **12B** may include vertical wall portions **31B**. For example, a portion of each of the vertical wall portions **31B** is cut out and the cut-out portion is bent and raised to form a receiving portion **60B** which supports the lower portion of the shaft member **50** arranged at an inner side of a bent portion **32B** of the upper rail **12B**. A method of forming the receiving portion **60B** may be arbitrarily modified. For example, a separate member may be fixedly attached to the vertical wall portions.

[0054] In the aforementioned embodiment, the upper rail **12** is provided with the tightened portions **61** (the welded portions **P1** and **P2**) which connect or join the upper end portions **31a** of the vertical wall portions **31** to each other at the end portions of the upper rail **12** in the lengthwise direction thereof, and thus reduce the diameter of the annular shape of the bent portion **32**. However, the tightened portion **61** may be provided at the upper rail **12** continuously over an entire range in the lengthwise direction of the upper rail **12**, or at plural positions over the entire range in the lengthwise direction of the upper rail **12**.

[0055] That is, in a case where the tightened portions **61** are provided at the end portions of the upper rail **12** in the lengthwise direction thereof, a clearance **X** is generated between the bent portion **32** and the shaft member **50** (and the buffer material **58**) as illustrated in FIG. 9 at an intermediate portion of the upper rail **12** in the lengthwise direction. However, with the above-described configuration, the clearance **X** is reduced. As a result, the shaft member **50** arranged at the inner side of the bent portion **32** is supported more reliably.

[0056] In the aforementioned embodiment, the tightened portion **61** is formed by connecting the upper end portions **31a** of the vertical wall portions **31** to each other by means of welding. However, a method of connecting the upper end portions **31a** of the vertical wall portions **31** is not limited to the welding. The upper end portions **31a** of the vertical wall portions **31** may be connected to each other by crimping or staking, or by fastening. Alternatively, the upper end portions **31a** may be connected to each other by adhesion or bonding. A structure of securing the shaft member **50** at the inner side of the bent portion **32B** may be arbitrarily modified. For example, the shaft member **50** may be fixed at the inner side of the bent portion **32B** by fastening or welding. Alternatively, the shaft member **50** may be fixed at the inner side of the bent portion **32B** by adhesion or bonding.

[0057] In the aforementioned embodiment, the pipe **53**, which corresponds to the hollow pipe, is used for the shaft member **50**. However, the shaft member **50** is not limited to the hollow pipe but may be a shaft which does not include a

hollow portion (that is, the shaft member 50 may be a so-called solid shaft member). In addition, the apparatus may include a configuration where the buffer material 58 is not interposed between the bent portion 32 and the shaft member 50.

[0058] Further, the threaded portions 52 provided at the shaft member 50 in the axial direction thereof are not limited to the internal threads formed at the inner periphery (that is, a nut configuration). The threaded portions 52 may be formed by external threads provided at an outer periphery of the shaft member 50 (that is, a bolt configuration). In that case, a length of a portion of the shaft member 50 at which the external threads are not provided may be defined as “the axial length L1 of the shaft member 50” and the axial length L1 may be set at a smaller value than the length L2 of the bent portion 32.

[0059] As illustrated in FIG. 10, the upper rail 12C includes a main portion 62. The main portion 62 includes vertical wall portions 31C and a bent portion 32C. A lightening portion 63 (an opening portion) may be provided at the main portion 62. That is, because the seat load is received by the shaft member 50, the main portion 62 is not required to include the high strength. As a result, the weight of the upper rail 12C is reduced while the high support rigidity of the upper rail 12C is maintained.

[0060] Next, technical ideas and effects thereof, which may be grasped from the aforementioned embodiment will be described. (A) According to the seat slide apparatus for the vehicle, the threaded portion 52 is used for fastening the bracket 13 (i.e., the support member) which is provided at the upper portion of the upper rail 12, 12B, 12C for supporting the seat 1. As a result, the seat 1 is supported reliably.

[0061] (B) According to the seat slide apparatus for the vehicle, the upper rail 12C includes the main portion 62 which includes the vertical wall portions 31C and the bent portion 32C, and the lightening portion 63 is provided at the main portion 62. As a result, the weight of the upper rail 12C is reduced.

[0062] According to the aforementioned embodiment, the seat slide apparatus for the vehicle includes the upper rail 12, 12B, 12C configured to support the seat 1 at the upper portion of the upper rail 12, 12B, 12C, the lower rail 11 supporting the upper rail 12, 12B, 12C in a manner that the upper rail 12, 12B, 12C and the lower rail 11 are movable relative to each other, and the shaft member 50 extended in the lengthwise direction of the upper rail 12, 12B, 12C, wherein the upper rail 12, 12B, 12C includes the pair of vertical wall portions 31, 31B, 31C extended in the upper/lower direction, the upper rail 12, 12B, 12C includes the bent portion 32, 32B, 32C connecting the vertical wall portions 31, 31B, 31C to each other at the upper portions of the vertical wall portions 31, 31B, 31C and the shaft member 50 is provided at the inner side of the bent portion 32, 32B, 32C, and the shaft member 50 includes the threaded portion 52 provided at each end thereof in the axial direction, the bent portion 32, 32B, 32C opening in the axial direction of the shaft member 50 includes the lengthwise-direction-end portions 51, and the threaded portions 52 of the shaft member 50 face the lengthwise-direction-end portions 51 of the bent portion 32, 32B, 32C.

[0063] According to the above-described configuration, the bolt 55 is threadedly attached to each of the threaded portions 52 of the shaft member 50 via the lengthwise-direction-end portion 51 of the bent portion 32, 32B, 32C. Thus, the seat 1 (or the bracket 13 for supporting the seat 1) is fastened to the upper portion of the upper rail 12, 12B, 12C with the fastening

force of the bolts 55. In addition, the shaft member 50 serves as the structural body, and thus the support rigidity of the upper rail 12, 12B, 12C is enhanced along the entire length thereof. That is, because the seat load is received by the shaft member 50, the deformation is not likely to occur to the vertical wall portions 31, 31B, 31C and the bent portion 32, 32B, 32C which constitute an outer shell (that is, the main portion 62) of the upper rail. Particularly, the bending strength of the upper rail 12, 12B, 12C in the lengthwise direction thereof may be enhanced significantly, thereby ensuring the high reliability. In addition, at the shaft member 50, the tensile force which elongates or pulls out the shaft member 50 is caused by the fastening which is achieved by threaded portion 52 provided at each of the axial ends of the shaft member 50. Thus, the fastened state is maintained stably.

[0064] Consequently, with the simple configuration, a higher support rigidity of the upper rail 12, 12B, 12C is ensured.

[0065] According to the aforementioned embodiment, the upper rail 12, 12B, 12C includes the receiving portion 60, 60B supporting the lower portion of the shaft member 50.

[0066] According to the above-described configuration, the shaft member 50 is held at the inner side of the bent portion 32, 32B, 32C against the seat load in the direction in which the shaft member 50 is pushed downwardly. Consequently, the high support rigidity is ensured.

[0067] According to the aforementioned embodiment, the bent portion 32, 32C includes the annular shape to which the shaft member 50 is fitted.

[0068] According to the above-described configuration, the shaft member 50 is maintained at the inner side of the bent portion 32, 32C easily and reliably with the simple configuration. Thus, the high support rigidity is assured.

[0069] According to the aforementioned embodiment, the shaft member 50 is held at the inner side of the bent portion 32, 32B, 32C against the seat load in the direction in which the shaft member 50 is pushed downwardly. Consequently, the high support rigidity is ensured.

[0070] According to the above-described configuration, the shaft member 50 is maintained at the inner side of the bent portion 32, 32C easily and reliably with the simple configuration. Thus, the high support rigidity is assured.

[0071] According to the aforementioned embodiment, the upper rail 12 includes the tightened portion 61 which connects the vertical wall portions 31 to each other and reduces the diameter of the annular shape of the bent portion 32.

[0072] According to the above-described configuration, after the shaft member 50 is arranged at the inner side of the bent portion 32, the diameter of the annular shape of the bent portion 32 is reduced and the shaft member 50 is attached to the inner side of the bent portion 32 by pressure (that is, the shaft member 50 is fitted to the inner side of the bent portion 32). Consequently, the shaft member 50 is held at the inside of the bent portion 32 easily and reliably.

[0073] According to the aforementioned embodiment, the shaft member 50 includes the axial length L1 that is set to be shorter than the length L2 of the bent portion 32.

[0074] According to the above-described configuration, the “elongation allowance δ ” for elongation caused by the fastening is provided at the shaft member 50 in advance, and thus the positioning of the upper rail 12 and the member fastened to the upper rail 12 is performed easily. Consequently, the fastening which is achieved by the threaded portions 52 is reliably ensured.

[0075] According to the aforementioned embodiment, the seat slide apparatus includes the buffer material **58** interposed between the bent portion **32** and the shaft member **50**.

[0076] According to the above-described configuration, the buffer material **58** is interposed between the bent portion **32** and the shaft member **50**, and thus the resonance frequency is lowered, or the resonance amplitude is reduced. As a result, the damping effect of the resonance is enhanced.

[0077] According to the aforementioned embodiment, the shaft member **50** is pre-coated with the buffer material **58**.

[0078] According to the above-described configuration, the vibration-proof effects and the sound-proof effects are obtained easily at low costs.

[0079] According to the aforementioned embodiment, the shaft member **50** corresponds to the pipe **53** which is hollow.

[0080] According to the above-described configuration, the weight of the shaft member **50** is reduced while the high strength is maintained. In addition, because the internal thread is formed at the inner periphery of the axial end portions of the pipe **53**, the threaded portions **52** are provided easily.

[0081] According to the aforementioned embodiment, the pipe **53** includes the threaded portion **52** provided at the inner periphery of each end of the pipe **53** in the axial direction thereof.

[0082] According to the aforementioned embodiment, the threaded portion **52** is configured to fasten the bracket **13** (i.e., the support member) provided at the upper portion of the upper rail **12**, **12B**, **12C** and supporting the seat **1**.

[0083] According to the above-described configuration, the seat **1** is supported reliably.

[0084] According to the aforementioned embodiment, the upper rail **12C** includes the main portion **62** which includes the vertical wall portions **31C** and the bent portion **32C**, and the lightening portion **63** is provided at the main portion **62**.

[0085] According to the above-described configuration, the weight of the upper rail **12C** is reduced.

[0086] According to the aforementioned embodiment, a seat apparatus for a vehicle includes the seat slide apparatus for the vehicle including the upper rail **12**, **12B**, **12C** configured to support the seat **1** at the upper portion of the upper rail **12**, **12B**, **12C**, the lower rail **11** supporting the upper rail **12**, **12B**, **12C** in a manner that the upper rail **12**, **12B**, **12C** and the lower rail **11** are movable relative to each other, and the shaft member **50** extended in the lengthwise direction of the upper rail **12**, **12B**, **12C**, wherein the upper rail **12**, **12B**, **12C** includes the pair of vertical wall portions **31**, **31B**, **31C** extended in the upper/lower direction, the upper rail **12**, **12B**, **12C** includes the bent portion **32**, **32B**, **32C** connecting the vertical wall portions **31**, **31B**, **31C** to each other at the upper portions of the vertical wall portions **31**, **31B**, **31C** and the shaft member **50** is provided at the inner side of the bent portion **32**, **32B**, **32C**, the shaft member **50** includes the threaded portion **52** provided at each end thereof in the axial direction, the bent portion **32**, **32B**, **32C** opening in the axial direction of the shaft member **50** includes the lengthwise-direction-end portions **51**, and the threaded portions **52** of the shaft member **50** face the lengthwise-direction-end portions **51** of the bent portion **32**, **32B**, **32C**, the seat **1**, the bracket **13** provided at the upper portion of the upper rail **12**, **12B**, **12C** and supporting the seat **1**, and the bolt **55** threadedly attached to each of the threaded portions **52**, and connecting the bracket **13**, the upper rail **12**, **12B**, **12C** and the shaft member **50** to each other.

[0087] According to the aforementioned embodiment, the bracket **13** includes the flange portion **54** facing the lengthwise-direction-end portion **51** of the bent portion **32**, **32B**, **32C**, and the insertion hole **56** into which the bolt **55** is inserted is provided at the flange portion **54**.

[0088] According to the aforementioned embodiment, the shaft member **50** includes the elongation allowance δ for the elongation caused by the fastening which is obtained by the bolt **55**.

[0089] According to the above-described configuration, the positioning of the bracket **13** is performed easily and the bracket **13** is fixed at the upper rail **12**, **12B**, **12C** reliably.

[0090] The principles, preferred embodiments and mode of operation of the present invention have been described in the foregoing specification. However, the invention which is intended to be protected is not to be construed as limited to the particular embodiments disclosed. Further, the embodiments described herein are to be regarded as illustrative rather than restrictive. Variations and changes may be made by others, and equivalents employed, without departing from the spirit of the present invention. Accordingly, it is expressly intended that all such variations, changes and equivalents which fall within the spirit and scope of the present invention as defined in the claims, be embraced thereby.

1. A seat slide apparatus for a vehicle, comprising:

an upper rail configured to support a seat at an upper portion of the upper rail;

a lower rail supporting the upper rail in a manner that the upper rail and the lower rail are movable relative to each other; and

a shaft member extended in a lengthwise direction of the upper rail, wherein

the upper rail includes a pair of vertical wall portions extended in an upper/lower direction,

the upper rail includes a bent portion connecting the vertical wall portions to each other at upper portions of the vertical wall portions and the shaft member is provided at an inner side of the bent portion, and

the shaft member includes a threaded portion provided at each end thereof in an axial direction, the bent portion opening in the axial direction of the shaft member includes lengthwise-direction-end portions, and the threaded portions of the shaft member face the lengthwise-direction-end portions of the bent portion.

2. The seat slide apparatus according to claim 1, wherein the upper rail includes a receiving portion supporting a lower portion of the shaft member.

3. The seat slide apparatus according to claim 1, wherein the bent portion includes an annular shape to which the shaft member is fitted.

4. The seat slide apparatus according to claim 1, wherein the bent portion includes an annular shape to which the shaft member is fitted, and the bent portion is configured to support a lower portion of the shaft member.

5. The seat slide apparatus according to claim 3, wherein the upper rail includes a tightened portion which connects the vertical wall portions to each other and reduces a diameter of the annular shape of the bent portion.

6. The seat slide apparatus according to claim 1, wherein the shaft member includes an axial length that is set to be shorter than a length of the bent portion.

7. The seat slide apparatus according to claim 1, further comprising:

a buffer material interposed between the bent portion and the shaft member.

8. The seat slide apparatus according to claim **7**, wherein the shaft member is pre-coated with the buffer material.

9. The seat slide apparatus according to claim **1**, wherein the shaft member corresponds to a pipe which is hollow.

10. The seat slide apparatus according to claim **9**, wherein the pipe includes the threaded portion provided at an inner periphery of each end of the pipe in an axial direction thereof.

11. The seat slide apparatus according to claim **1**, wherein the threaded portion is configured to fasten a support member provided at the upper portion of the upper rail and supporting the seat.

12. The seat slide apparatus according to claim **1**, wherein the upper rail includes a main portion which includes the vertical wall portions and the bent portion, and a lightening portion is provided at the main portion.

13. A seat apparatus for a vehicle, comprising:

a seat slide apparatus for a vehicle, including an upper rail configured to support a seat at an upper portion of the upper rail, a lower rail supporting the upper rail in a manner that the upper rail and the lower rail are movable relative to each other, and a shaft member extended in a lengthwise direction of the upper rail, wherein the upper rail includes a pair of vertical wall portions extended in an upper/lower direction, the upper rail includes a bent

portion connecting the vertical wall portions to each other at upper portions of the vertical wall portions and the shaft member is provided at an inner side of the bent portion, the shaft member includes a threaded portion provided at each end thereof in an axial direction, the bent portion opening in the axial direction of the shaft member includes lengthwise-direction-end portions, and the threaded portions of the shaft member face the lengthwise-direction-end portions of the bent portion;

the seat;

a support member provided at the upper portion of the upper rail and supporting the seat; and

a connection member threadedly attached to each of the threaded portions, and connecting the support member, the upper rail, and the shaft member to each other.

14. The seat apparatus according to claim **13**, wherein the support member includes a flange portion facing the lengthwise-direction-end portion of the bent portion, and

an insertion hole into which the connection member is inserted is provided at the flange portion.

15. The seat apparatus according to claim **14**, wherein the shaft member includes an elongation allowance for elongation caused by fastening which is obtained by the connection member.

* * * * *