



US 20230358913A1

(19) **United States**

(12) **Patent Application Publication**  
**EIDINGER et al.**

(10) **Pub. No.: US 2023/0358913 A1**

(43) **Pub. Date: Nov. 9, 2023**

(54) **SYSTEMS AND METHODS FOR LOCATING A METAL OBJECT**

(71) Applicant: **Stanley Black & Decker Inc.**, New Britain, CT (US)

(72) Inventors: **Bruce EIDINGER**, Meriden, CT (US);  
**Yong Cushing**, Beacon Falls, CT (US);  
**Michael Murray**, Vernon, CT (US);  
**Bianca Linay**, Waldwick, NJ (US)

(73) Assignee: **Stanley Black & Decker Inc.**, New Britain, CT (US)

(21) Appl. No.: **18/221,630**

(22) Filed: **Jul. 13, 2023**

**Related U.S. Application Data**

(63) Continuation of application No. 17/378,888, filed on Jul. 19, 2021, now Pat. No. 11,740,379, which is a continuation of application No. 16/663,960, filed on Oct. 25, 2019, now Pat. No. 11,067,714, which is a

continuation of application No. 16/224,063, filed on Dec. 18, 2018, now Pat. No. 10,908,312, which is a continuation-in-part of application No. 15/632,175, filed on Jun. 23, 2017, now Pat. No. 10,571,423.

(60) Provisional application No. 62/354,176, filed on Jun. 24, 2016.

**Publication Classification**

(51) **Int. Cl.**  
**G01V 3/165** (2006.01)

(52) **U.S. Cl.**  
CPC ..... **G01V 3/165** (2013.01)

(57) **ABSTRACT**

A device for locating an object. The device includes a housing including a first hole. The device also includes a sensor carried by the housing and comprising two or more electrodes that are positioned next to each other to form a substantially circular configuration. The sensor includes a second hole formed in the center of the circular configuration, and the second hole is axially aligned with the first hole.

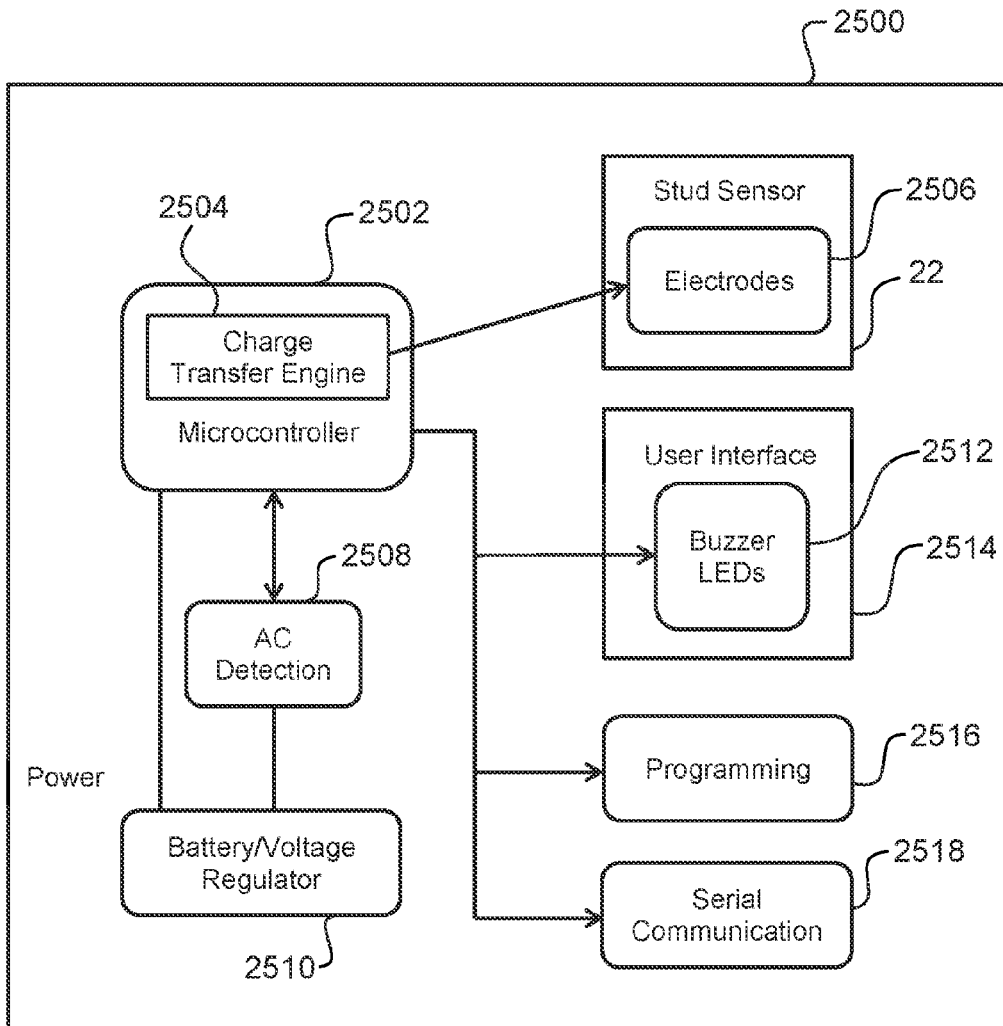

100 ↗

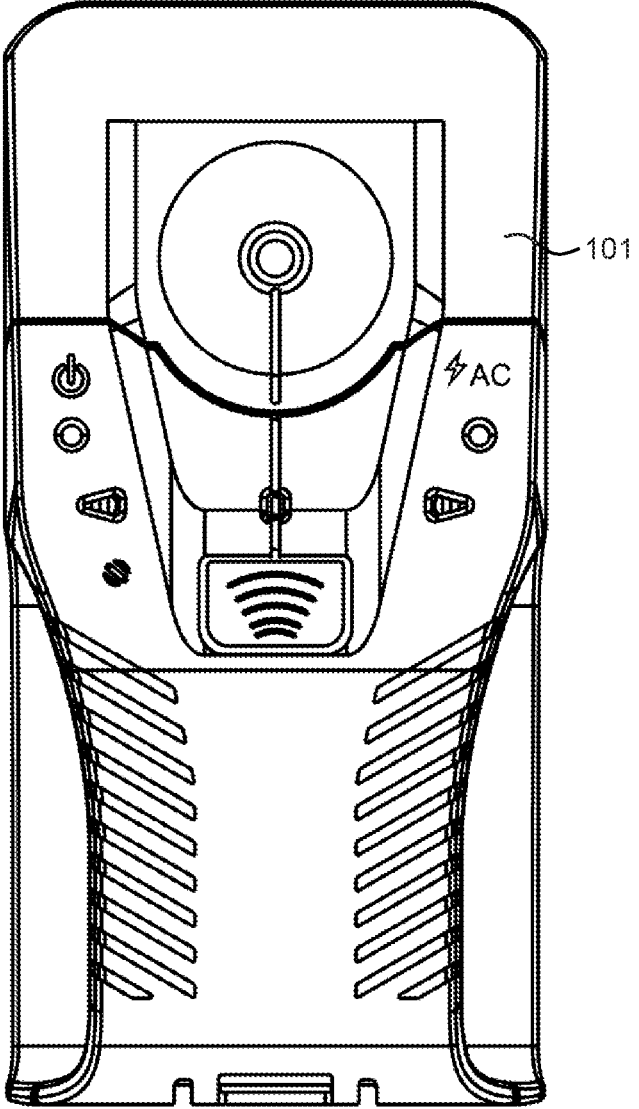

FIG. 1A

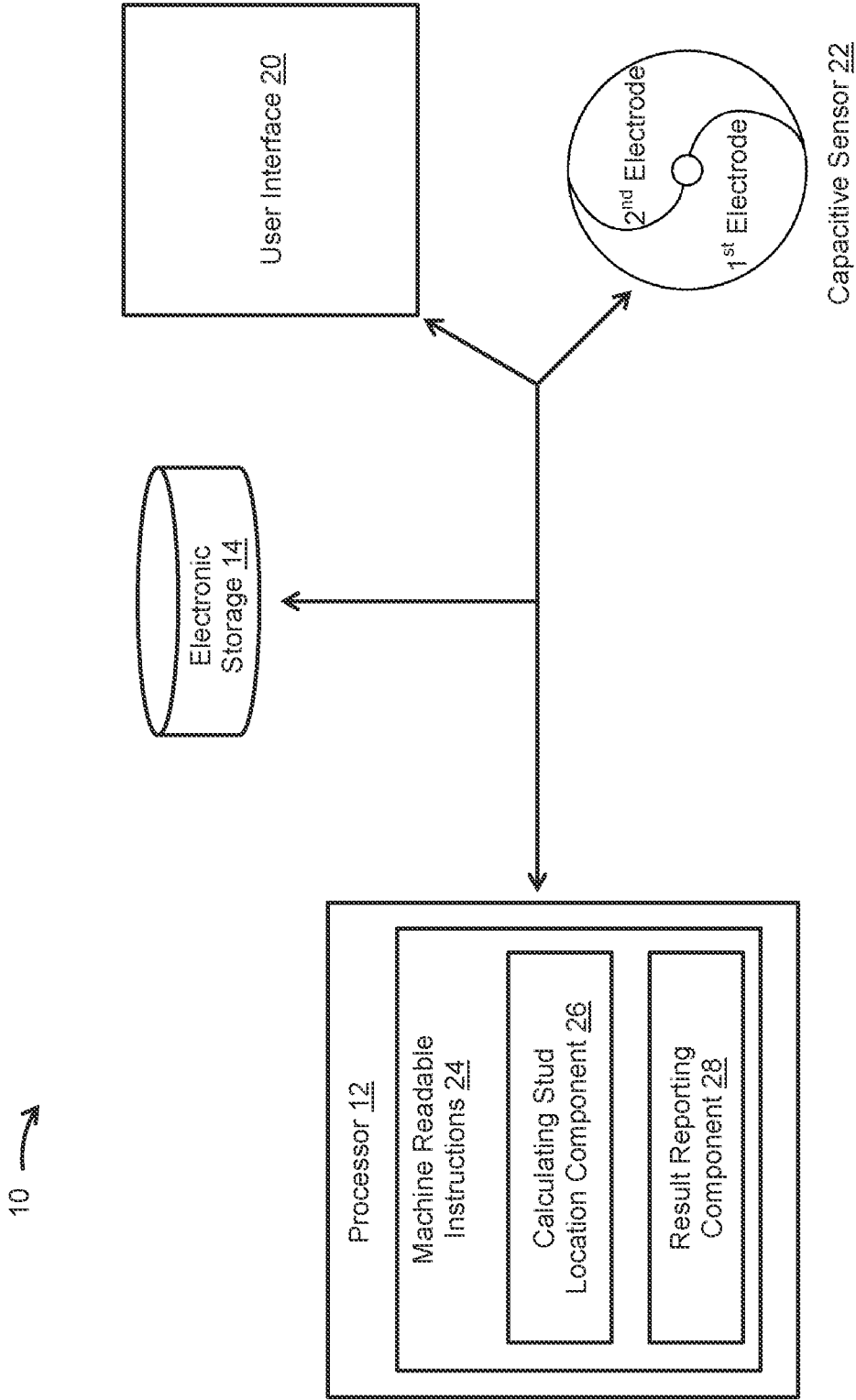

FIG. 1B

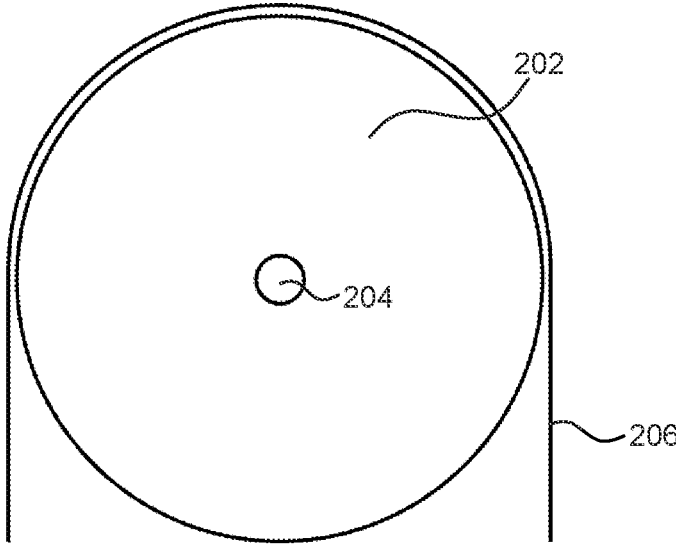

FIG. 2

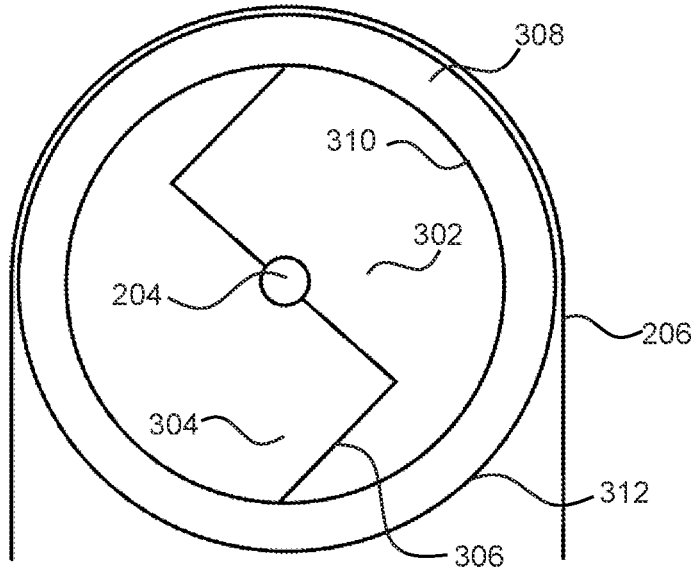

FIG. 3

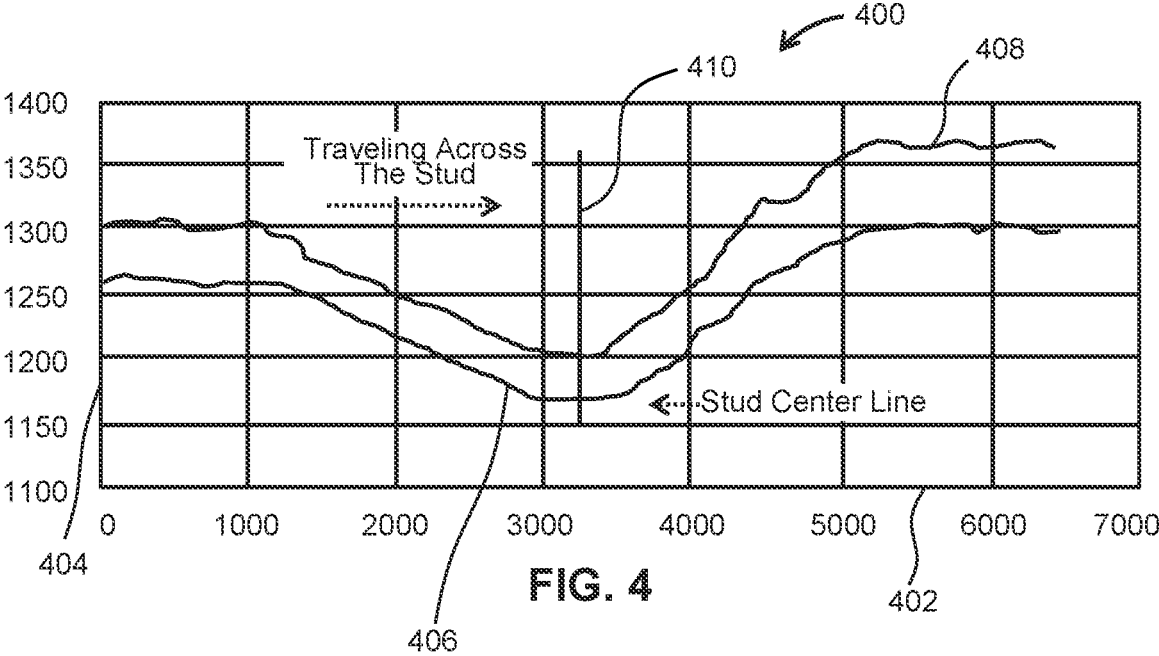
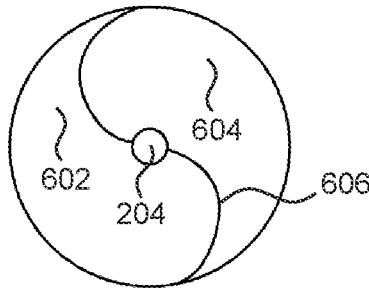

FIG. 4

Wall depth (in.)	Minimum Area of Round Circle (sq. in.)
0.5	0.38
0.75	0.66
1.0	0.79
1.5 and above	1.77

**FIG. 5**



**FIG. 6**

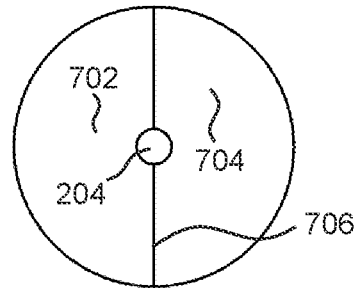

**FIG. 7**

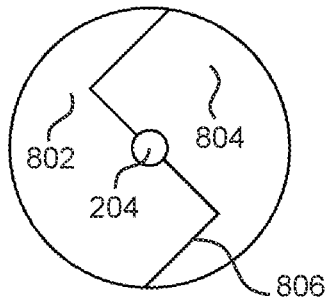

**FIG. 8**

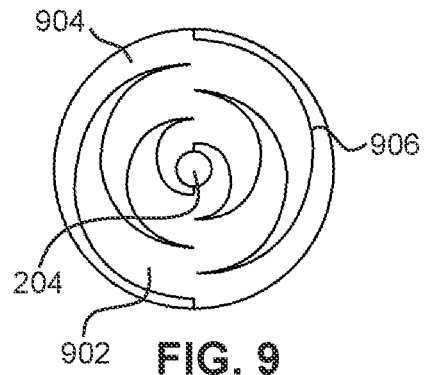

**FIG. 9**

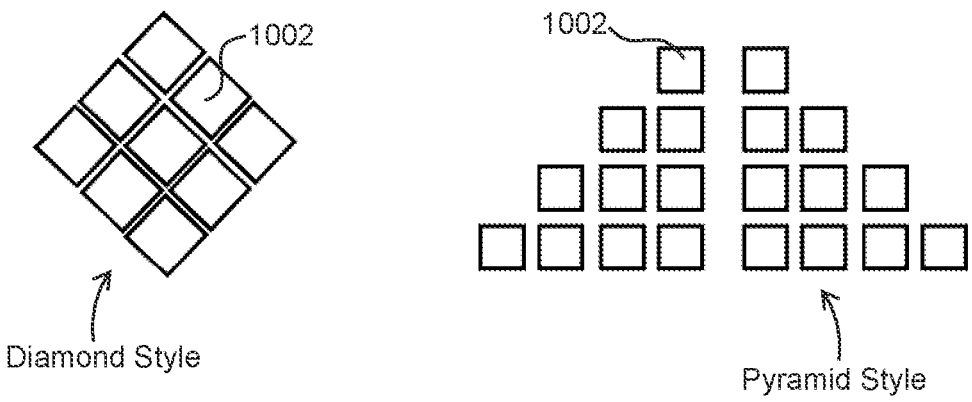

FIG. 10

Wall depth (in.)	Minimum square electrode area (sq. in.)
0.5	0.095
0.75	0.165
1.0	0.1975
1.5 or above	0.4425

FIG. 11

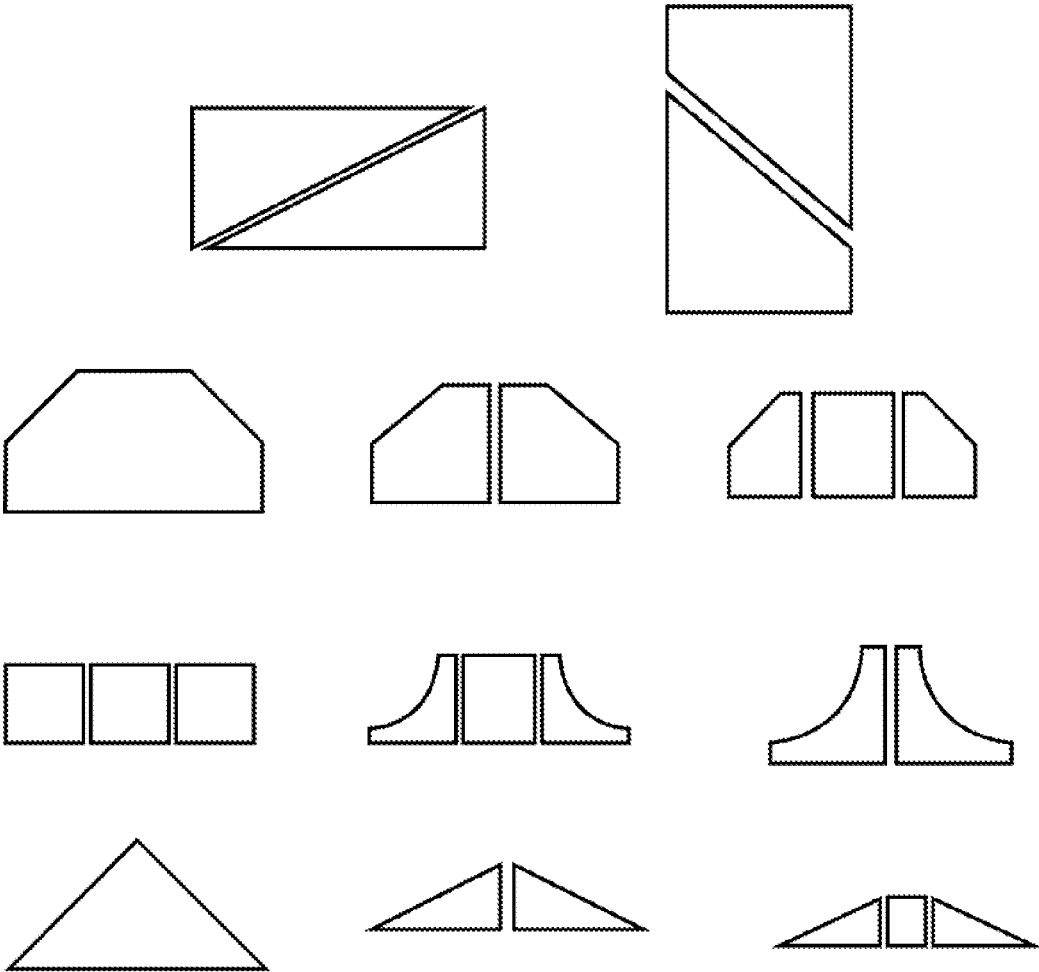

FIG. 12



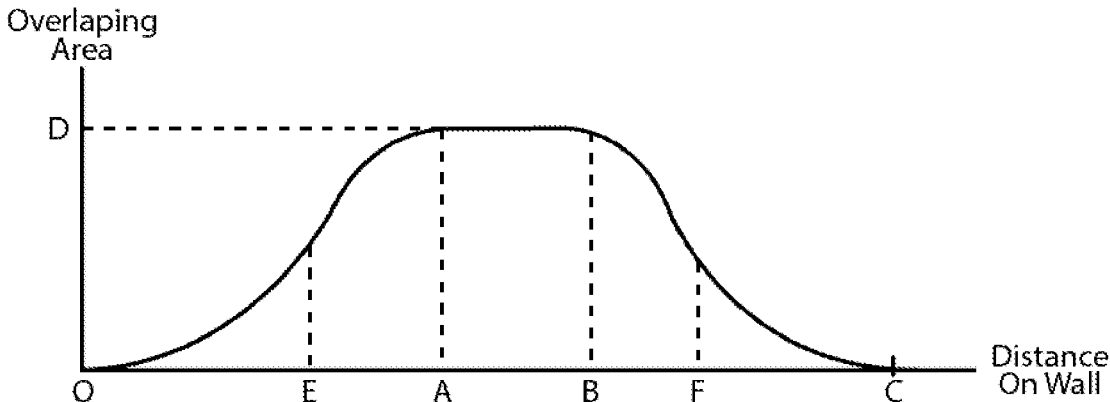

FIG. 13

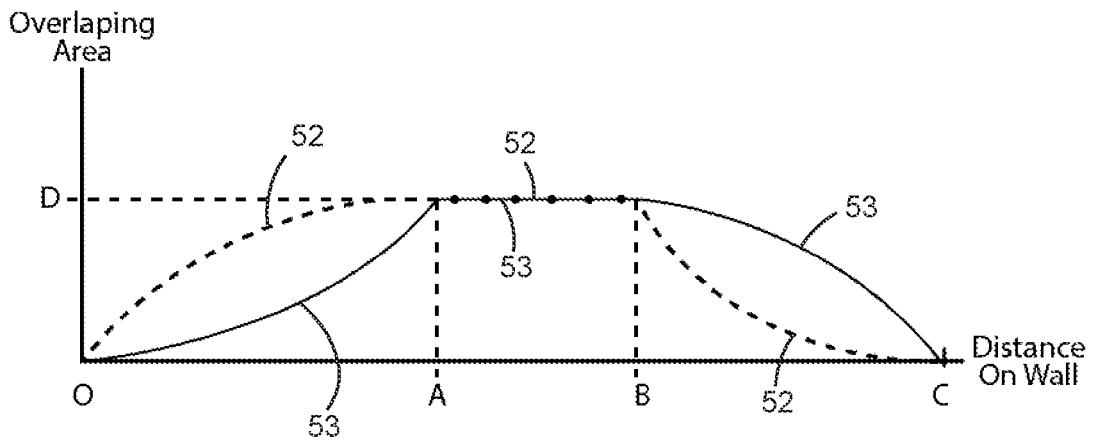

FIG. 14

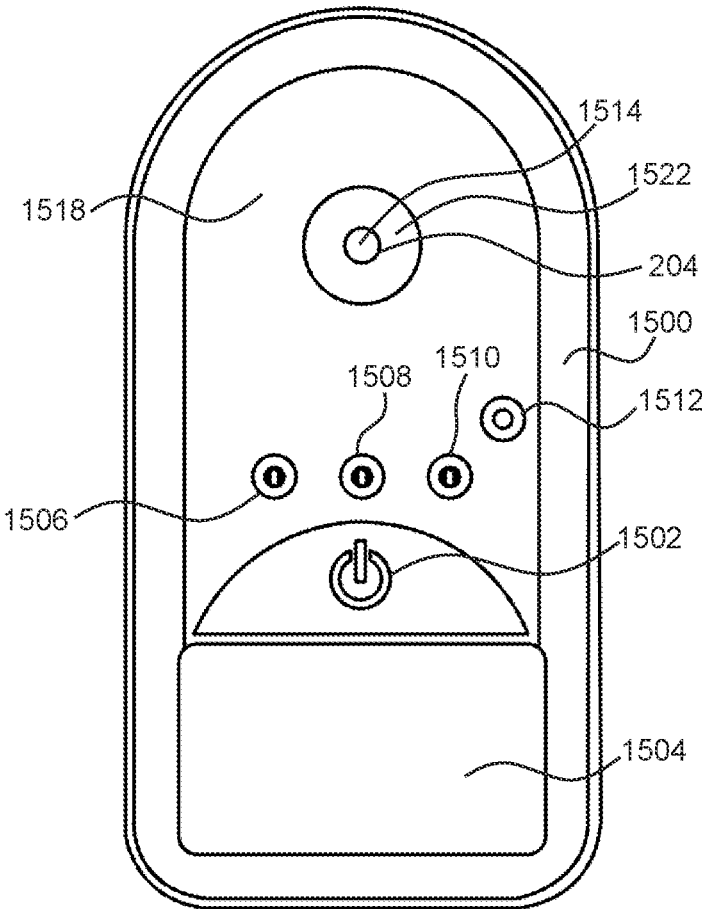

FIG. 15

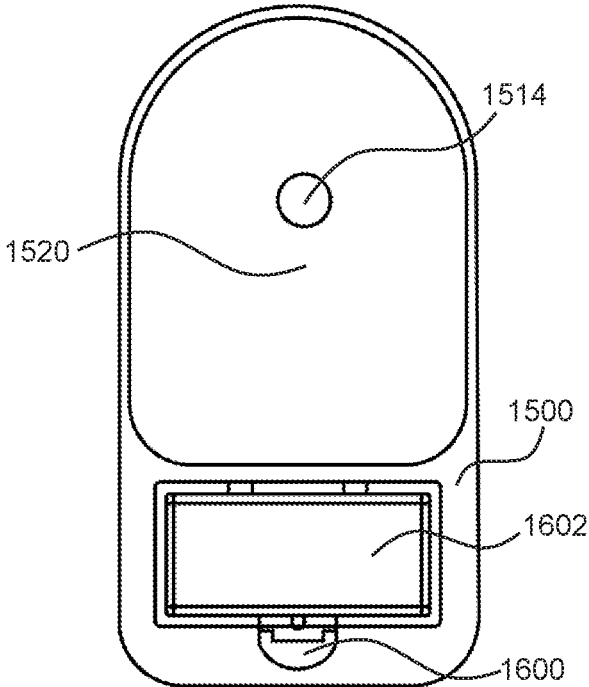

FIG. 16

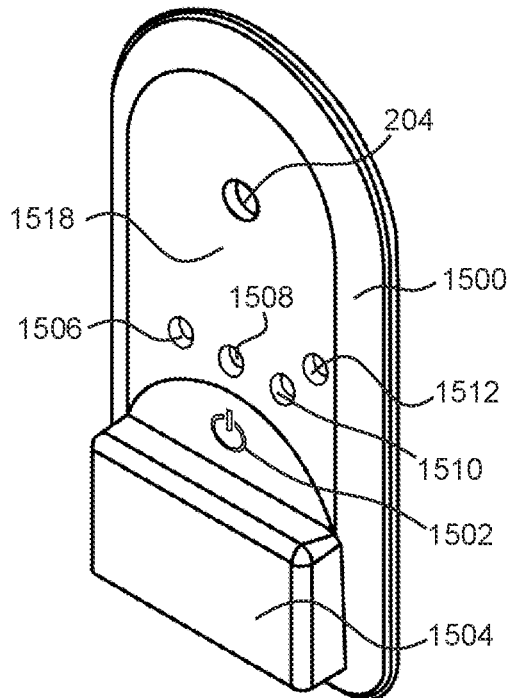

FIG. 17

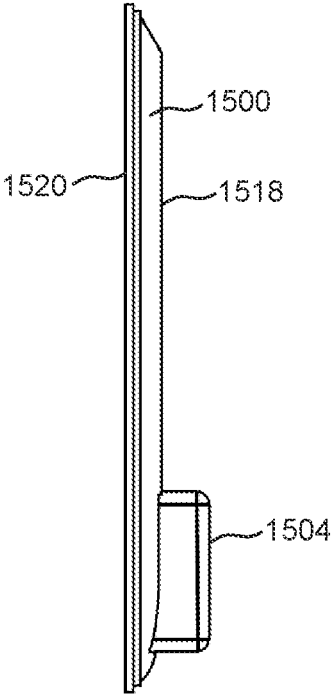

FIG. 18

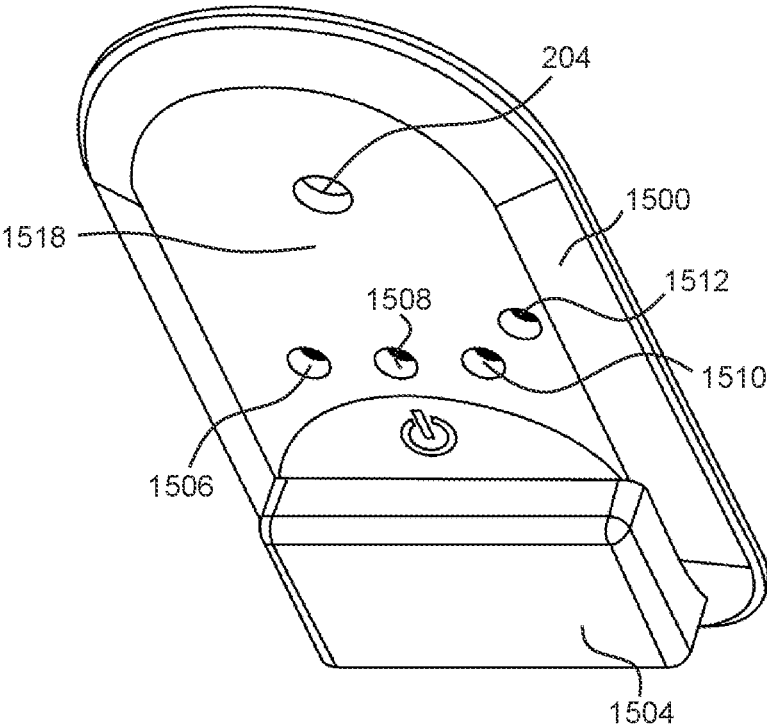

FIG. 19

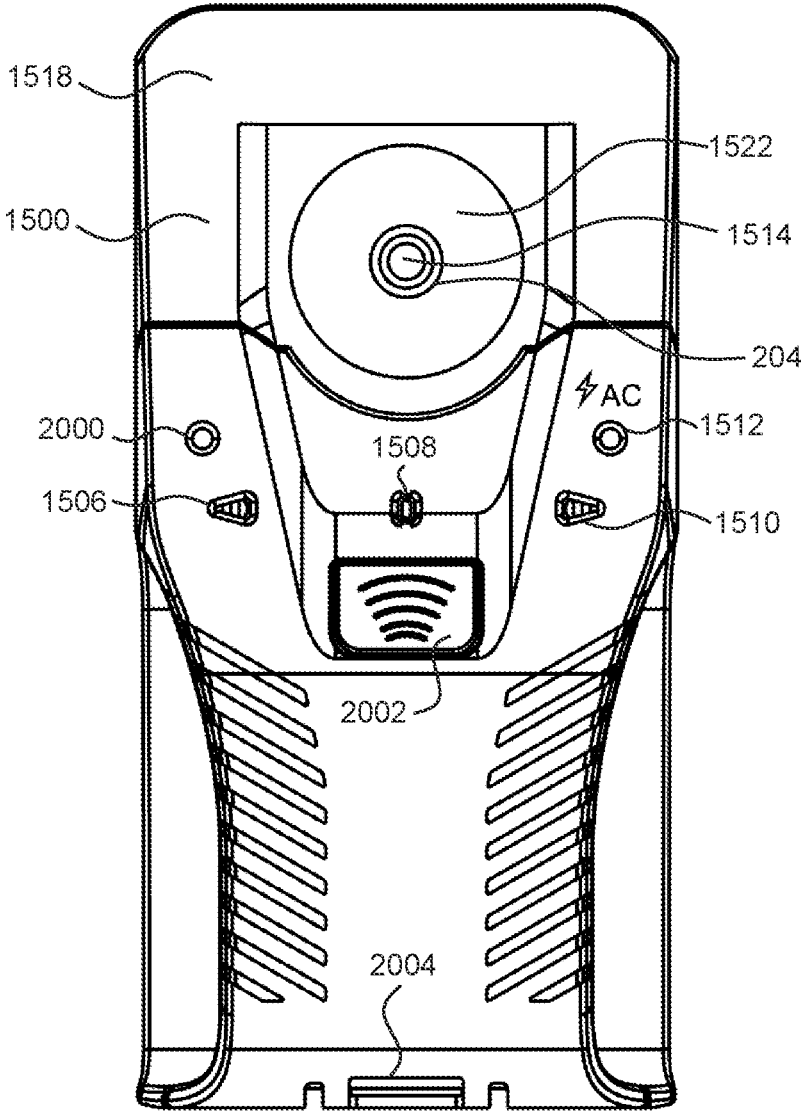

FIG. 20

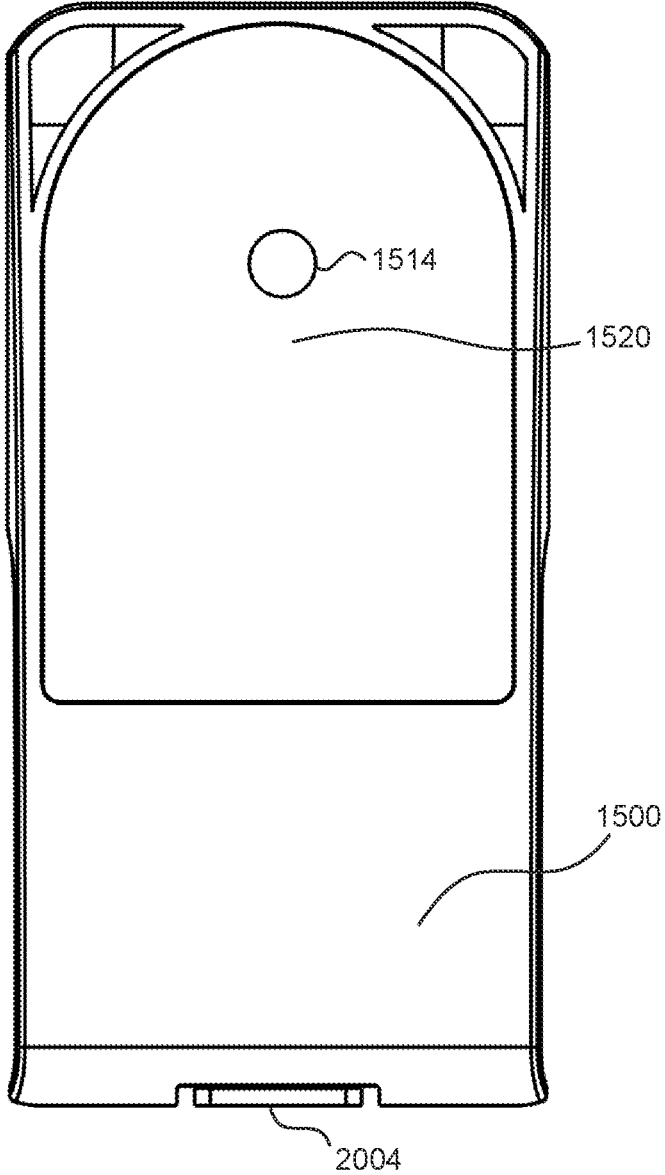

FIG. 21

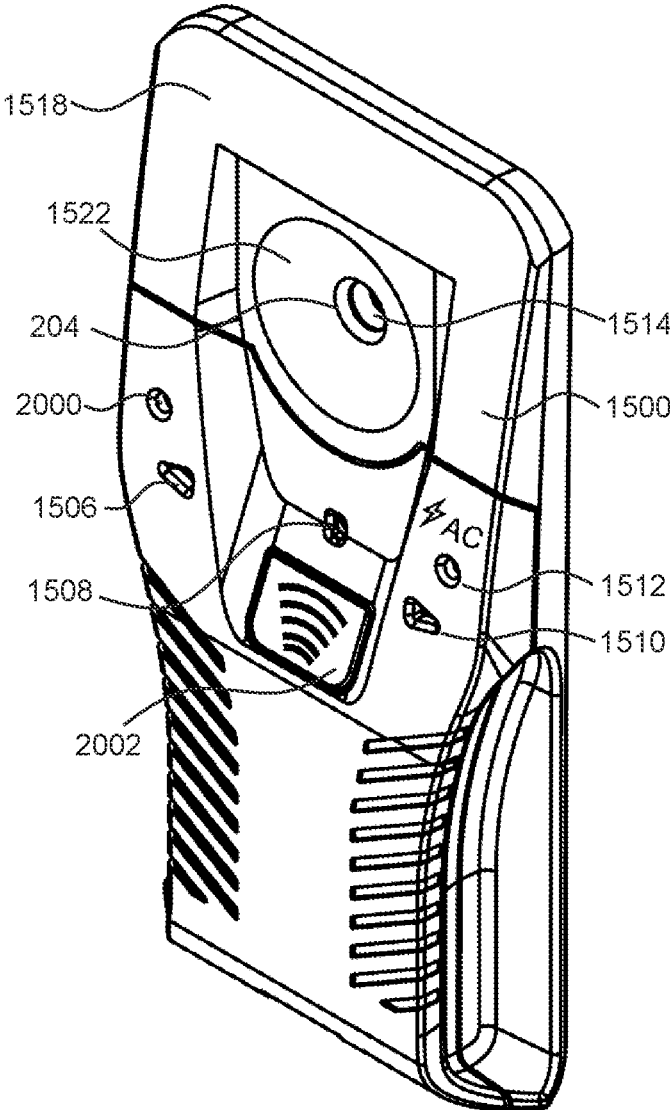

FIG. 22

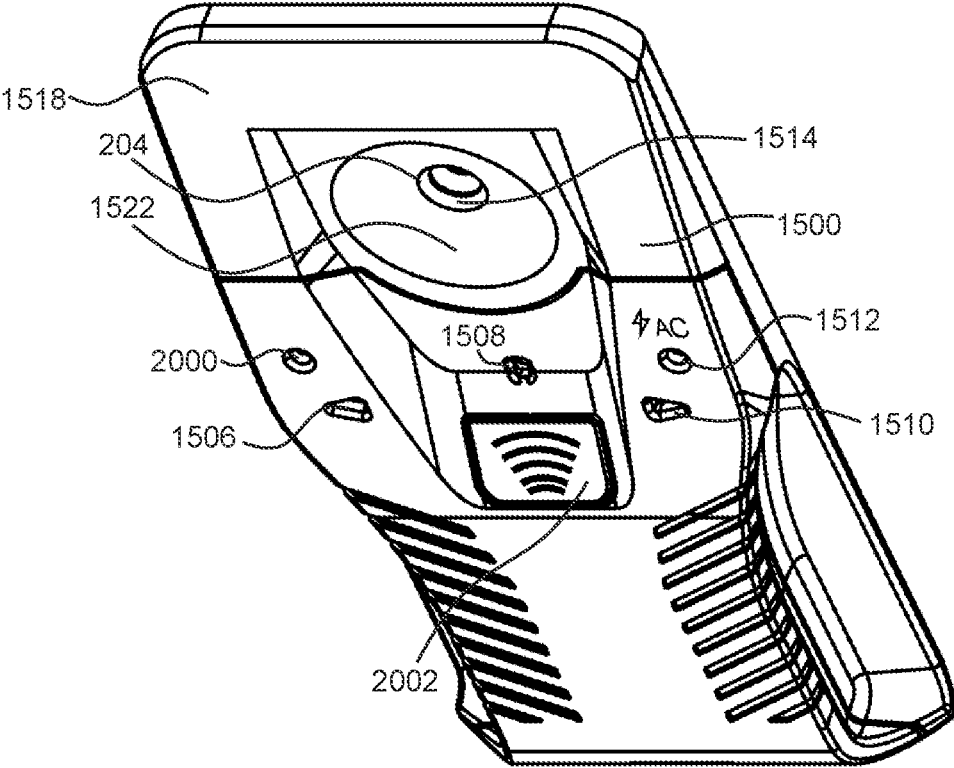

FIG. 23



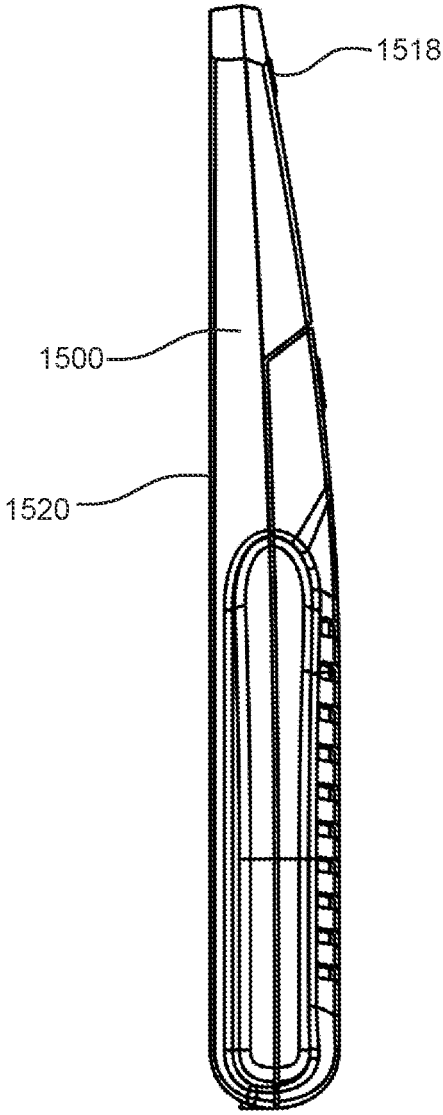

FIG. 24

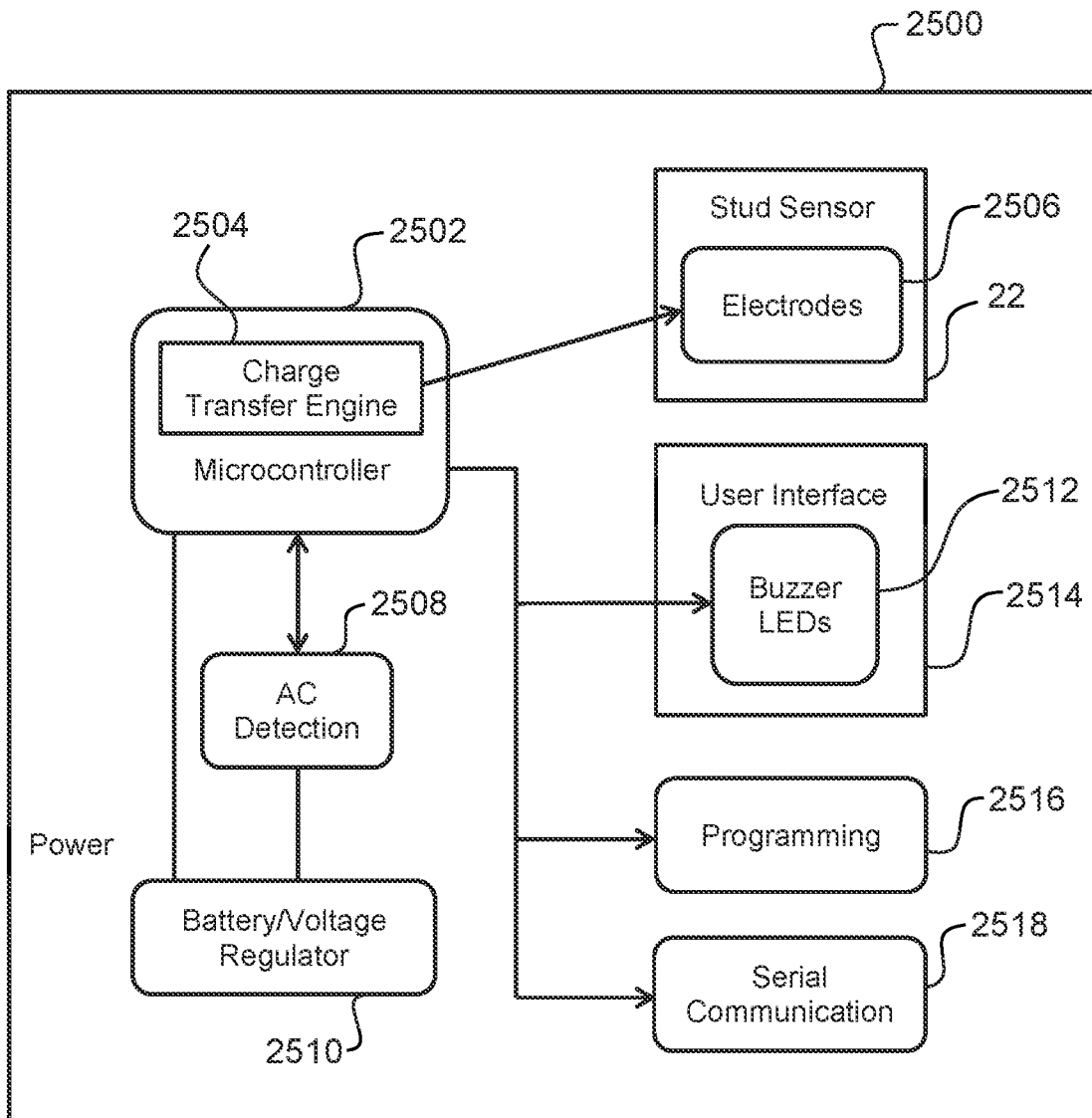

FIG. 25

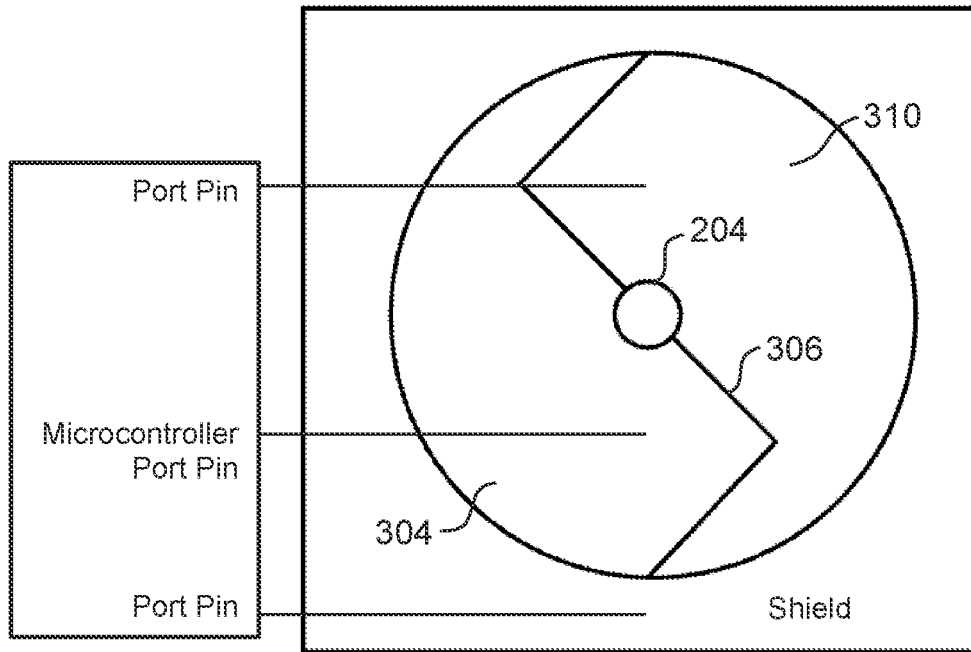

FIG. 26

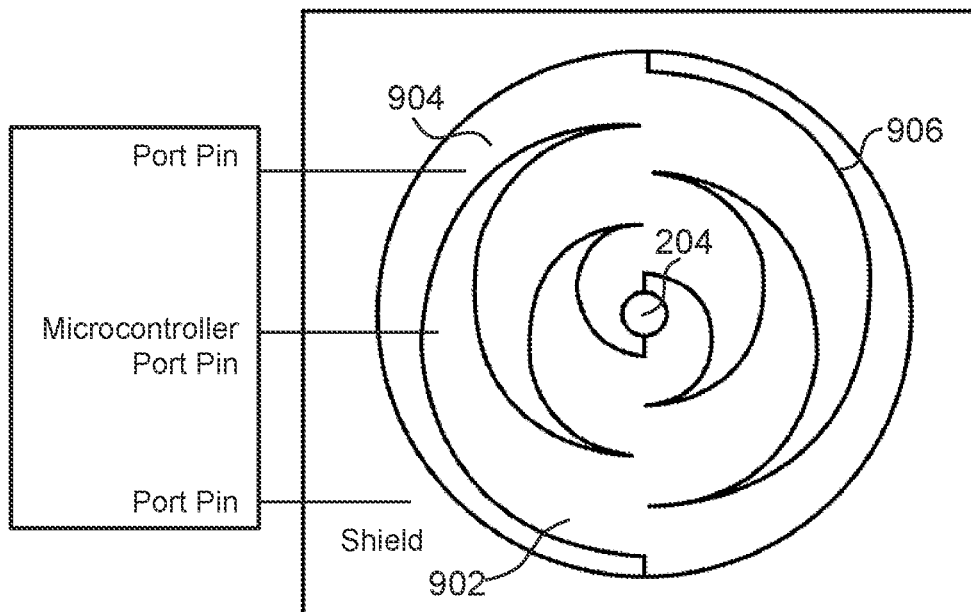

FIG. 27

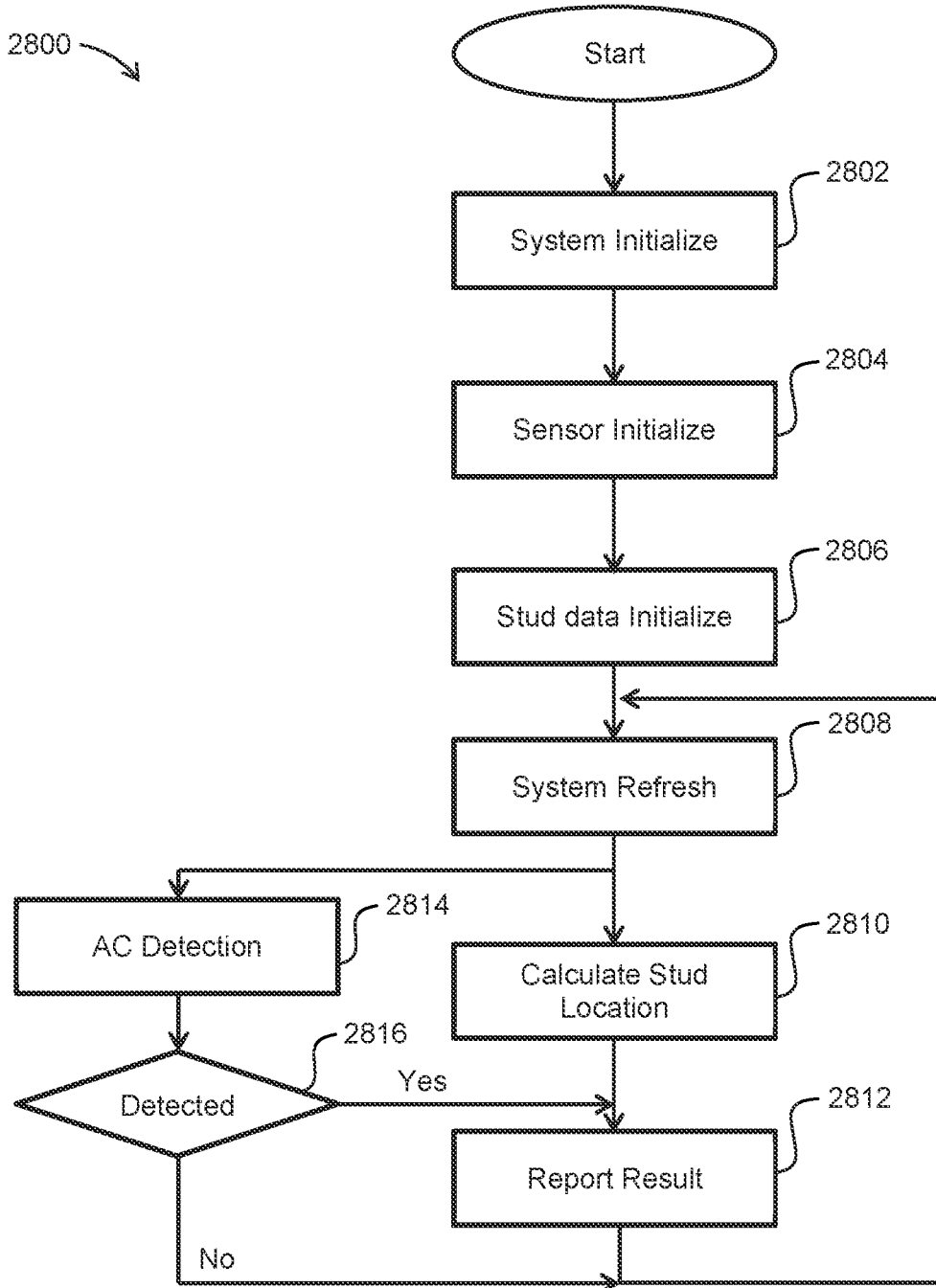

FIG. 28

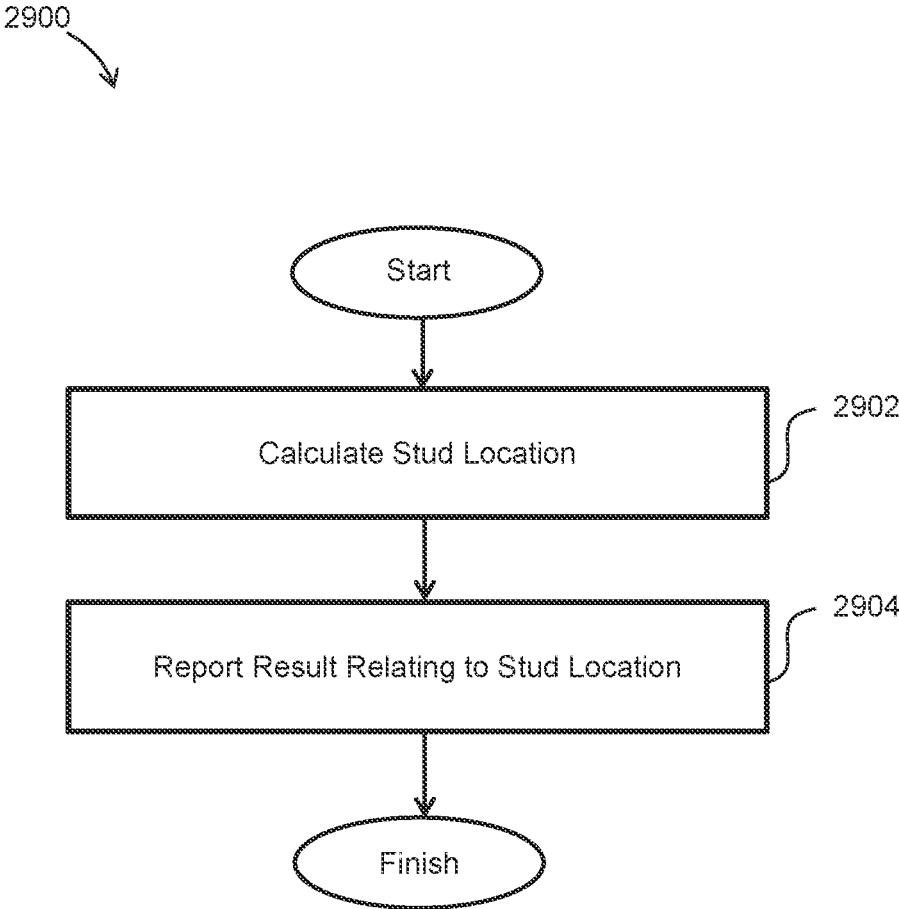

FIG. 29

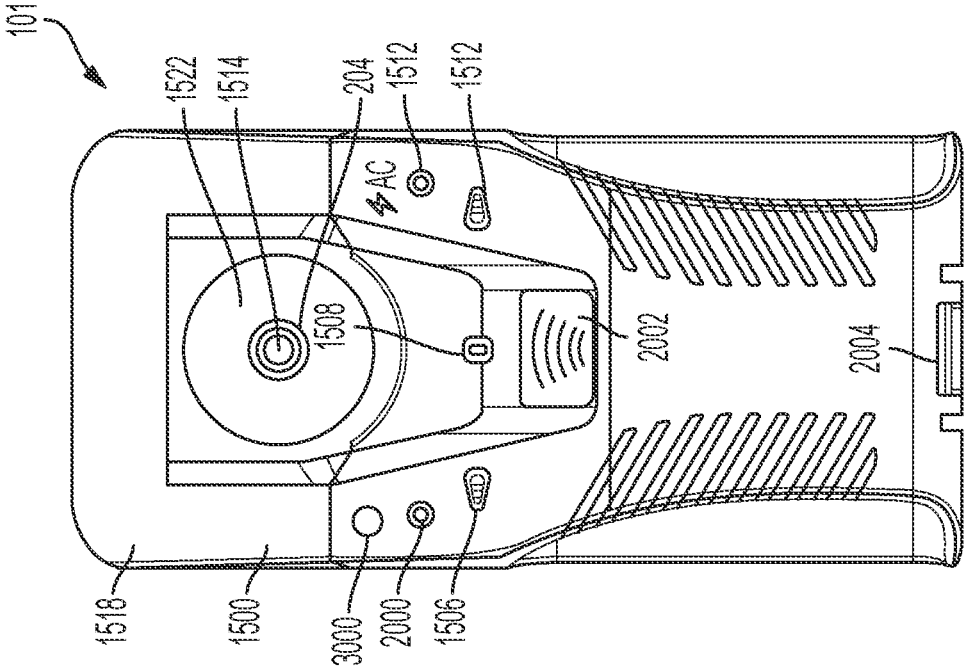

Fig. 30

Fig. 32

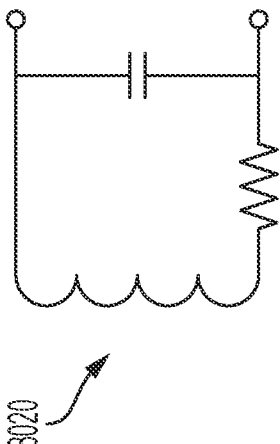
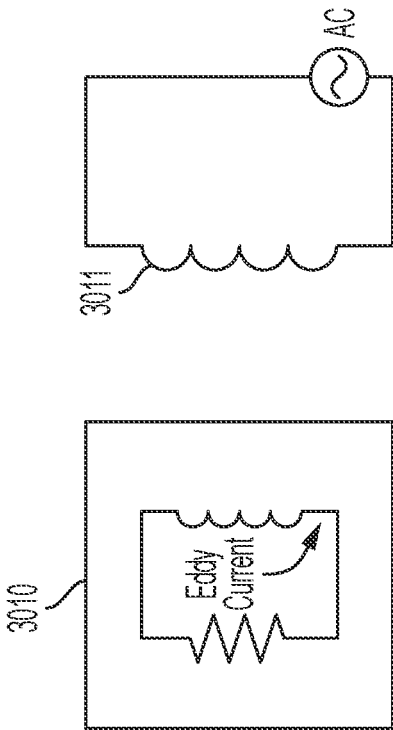

Fig. 31



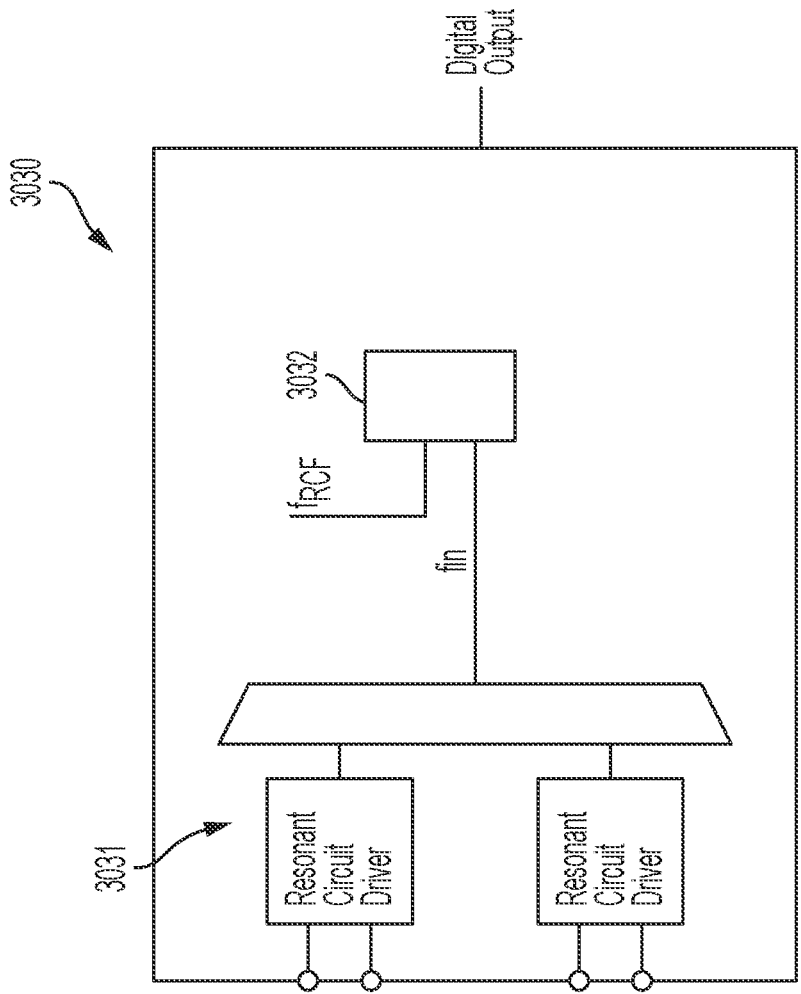

Fig. 33A



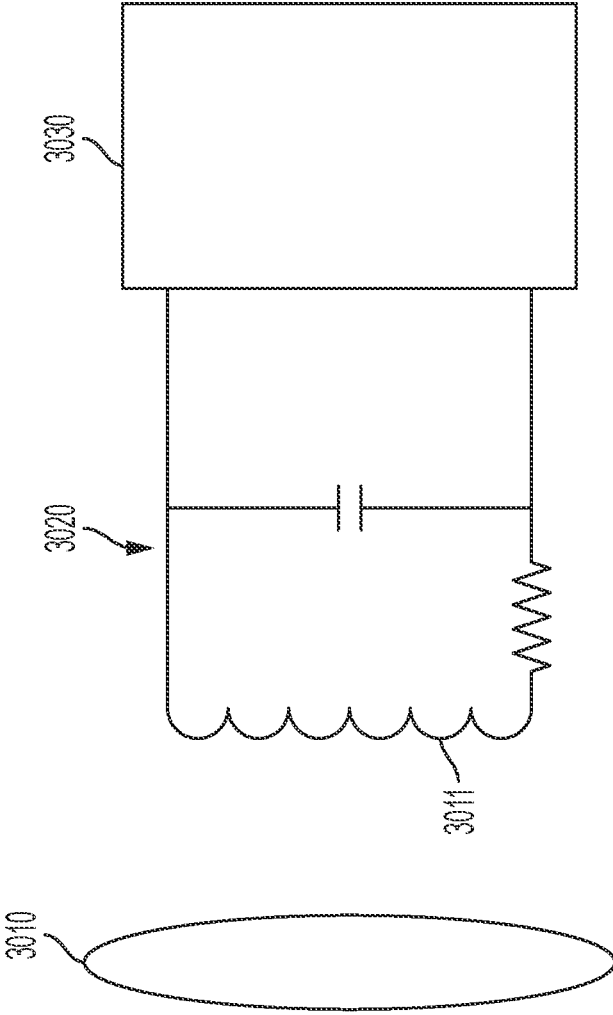

Fig. 33B

PRIOR ART

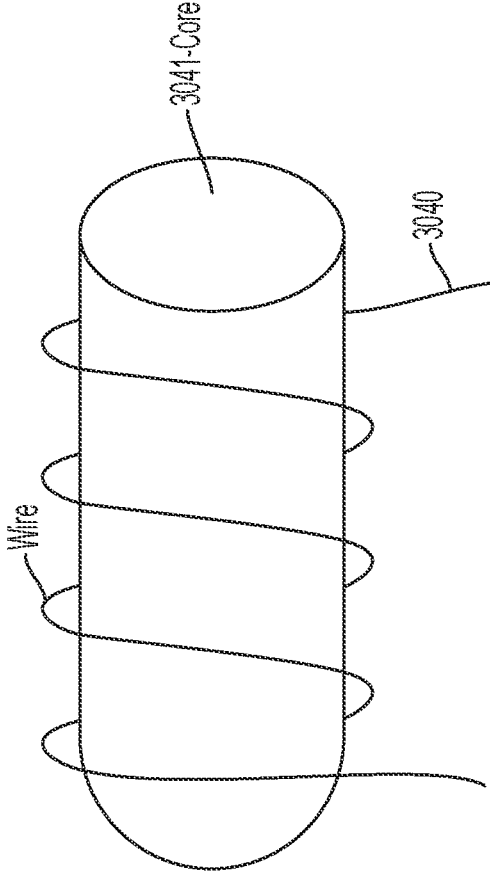

Fig. 34

Fig. 36

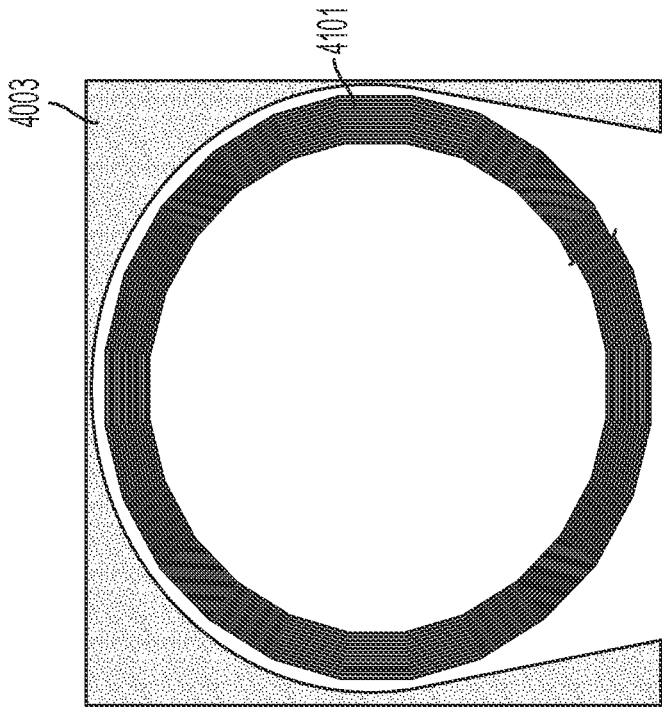
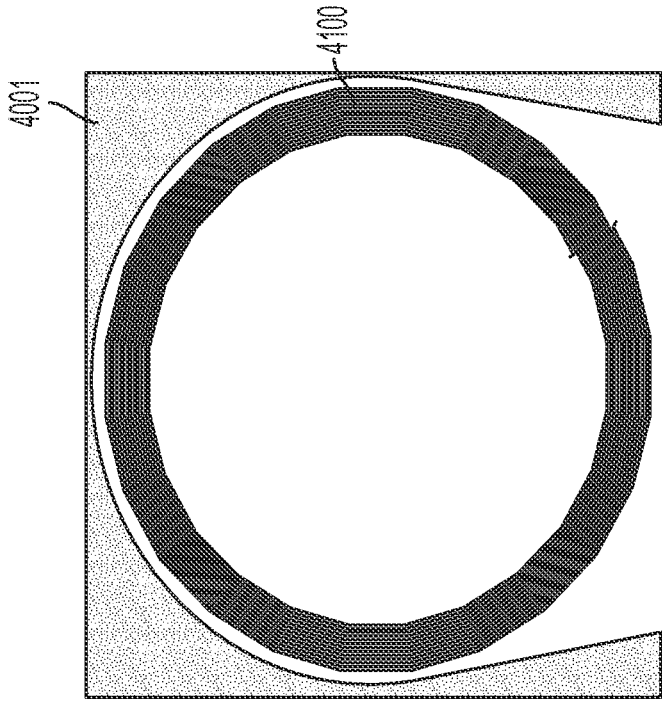

Fig. 35



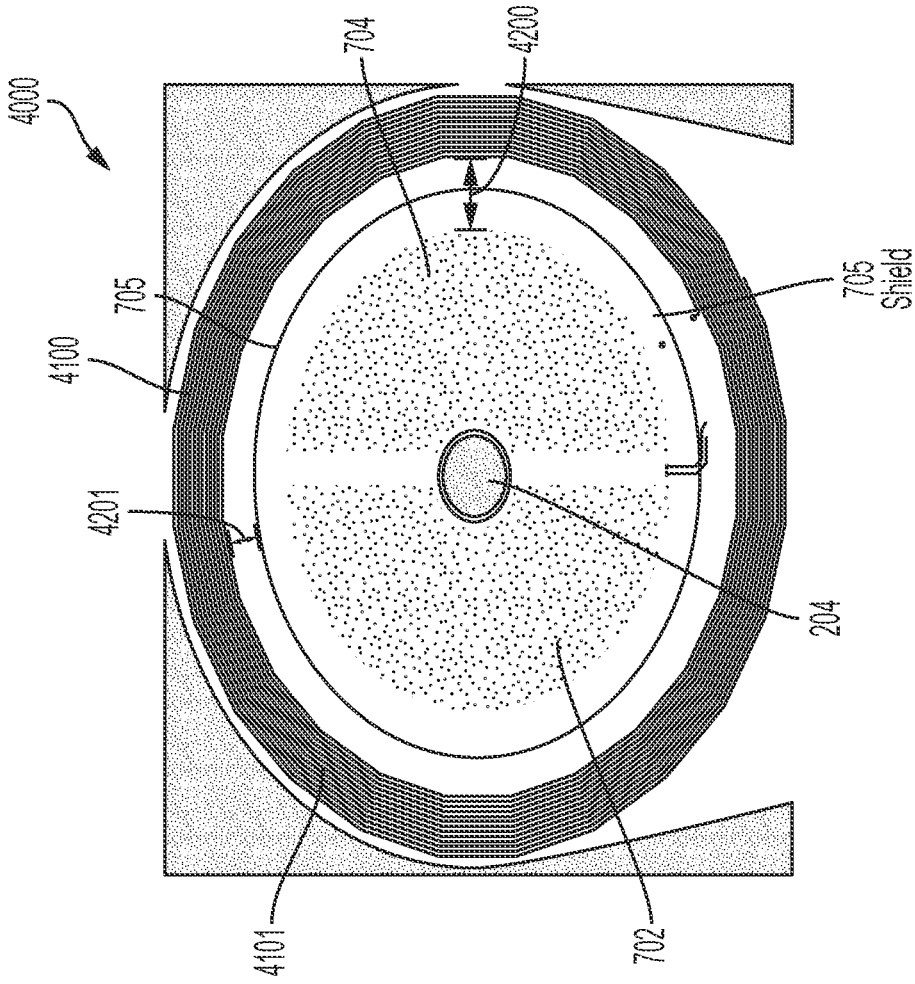

Fig. 37A

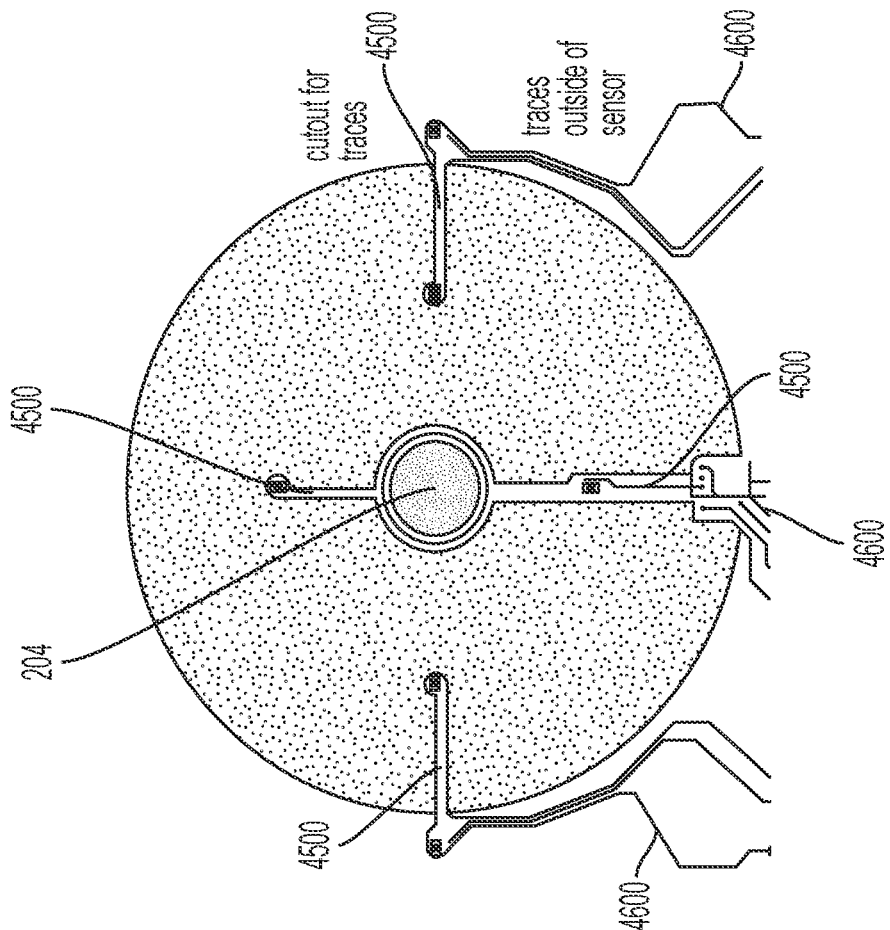

Fig. 37B

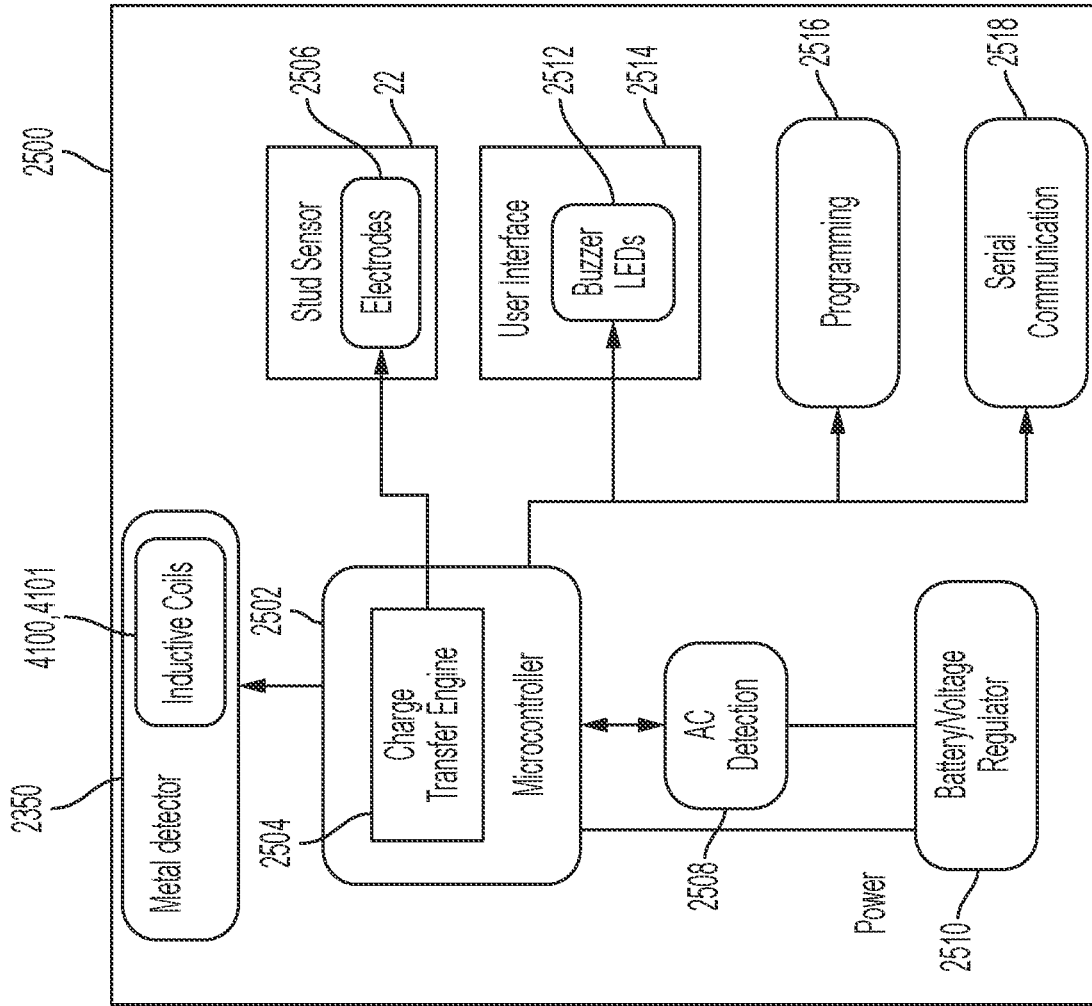

Fig. 38

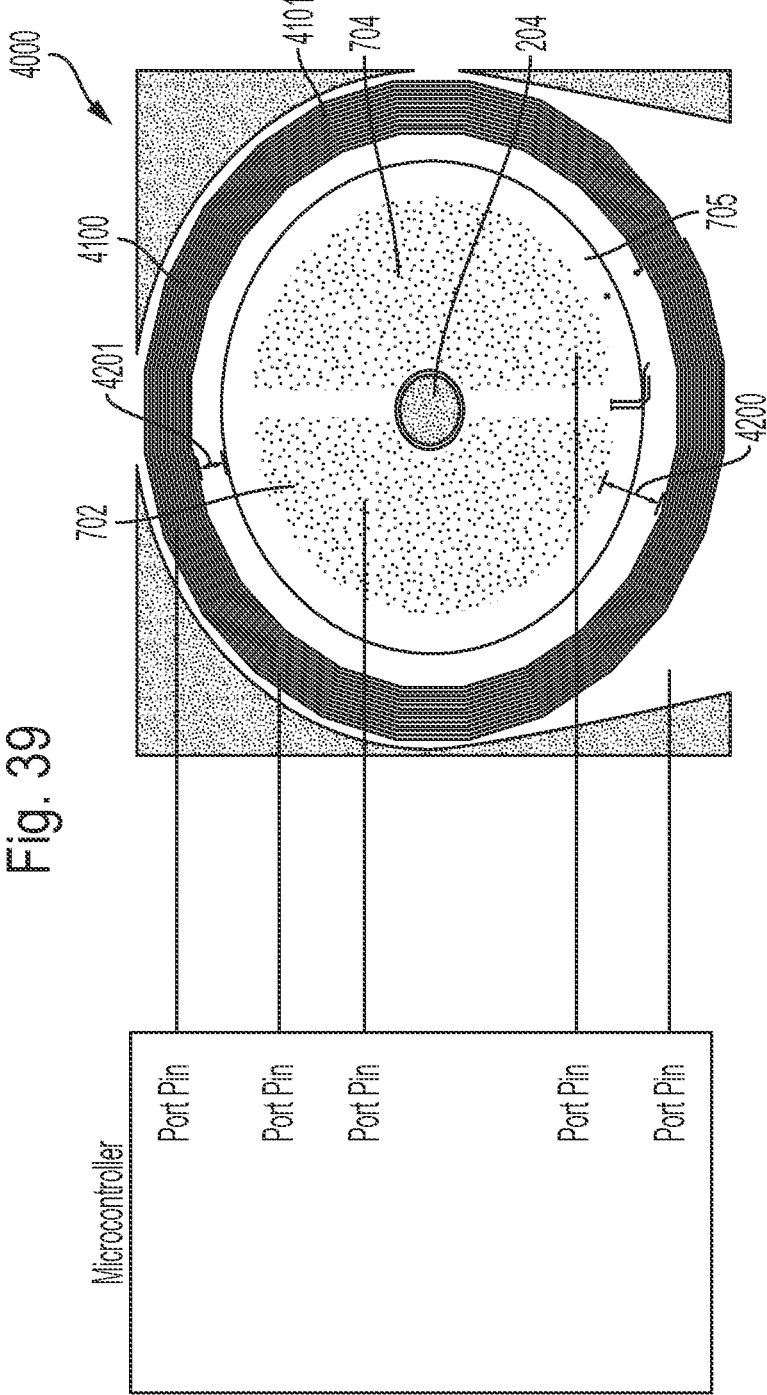

Fig. 39

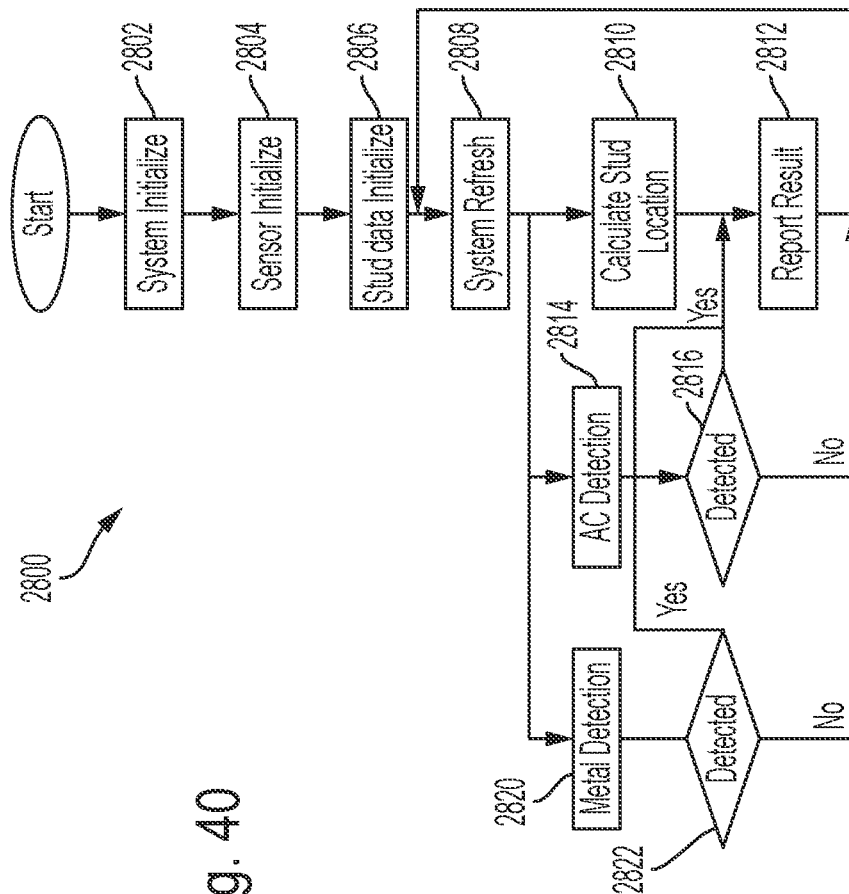

Fig. 40



## SYSTEMS AND METHODS FOR LOCATING A METAL OBJECT

### CROSS-REFERENCE TO RELATED APPLICATION

**[0001]** This application is a continuation of U.S. patent application Ser. No. 17/378,888 filed on Jul. 19, 2021, which is a continuation of U.S. patent application Ser. No. 16/663,960 filed on Oct. 25, 2019, which is a continuation of U.S. patent application Ser. No. 16/224,063, filed on Dec. 18, 2018, which is a continuation-in-part of U.S. patent application Ser. No. 15/632,175, filed on Jun. 23, 2017, which claims priority and benefit to U.S. Provisional Application No. 62/354,176, filed on Jun. 24, 2016, and titled “STUD FINDER”. The entire contents of each of the above applications are hereby incorporated herein by reference in their entirety.

### BACKGROUND

#### 1. Field

**[0002]** The present disclosure pertains to systems and methods for locating an object, such as a stud, behind the surface of a wall structure or other structure.

#### 2. Description of the Related Art

**[0003]** There are various existing sensing devices for sensing and locating objects behind walls and other building surfaces. One type of sensing device uses capacitive sensors for locating studs behind the surface of the wall or other structure. One aspect of the present application provides an improvement in stud sensors, and in particular capacitive sensors for use in a stud sensing apparatus.

### SUMMARY

**[0004]** Accordingly, one or more aspects of the present disclosure relate to a stud sensor configured to locate a stud. The stud sensor comprises a housing and a sensor carried by the housing. The sensor comprises two or more electrodes. The two or more electrodes are configured to form a substantially circular configuration. The stud sensor further comprises one or more processors carried by the housing. The one or more processors are communicatively coupled with the sensor. The one or more processors are configured by machine-readable instructions to calculate a stud location by measuring a change in capacitance from a fixed capacitance of a wall structure as the stud sensor is moved along a surface of the wall structure; and generate one or more signals to report a result relating to a location of a stud.

**[0005]** Another aspect of the present disclosure relates to a stud sensor configured to locate a stud. The stud sensor comprises a housing and a sensor carried by the housing. The sensor comprises two or more interdigitating electrodes. The stud sensor further comprises one or more processors carried by the housing. The one or more processors are communicatively coupled with the sensor. The one or more processors are configured by machine-readable instructions to calculate a stud location by measuring a change in capacitance from a fixed capacitance of a wall structure as the stud sensor is moved along a surface of the wall structure; and generate one or more signals to report a result relating to a location of a stud.

**[0006]** Still another aspect of present disclosure relates to a method for locating a stud with a stud sensor configured to locate a stud. The stud sensor comprises a housing and a sensor carried by the housing. The stud sensor comprises two or more electrodes configured to form a substantially circular configuration. The stud sensor comprises audio and/or visual indicators carried by the housing, and one or more processors communicatively coupled with the two or more electrodes and the audio and/or visual indicators. The one or more processors are configured to generate output signal to the audio and/or visual indicators when a result relating to a location of a stud is determined. A hole is provided through the housing and substantially centered between the sensors. The method comprises calculating a stud location by measuring a change in capacitance from a fixed capacitance of a wall structure as a back surface of the stud sensor housing is moved along a surface of the wall structure; reporting a result relating to a location of a stud based on the change in capacitance; indicating the result relating to the location of the stud via the audio and/or visual indicators; and wherein the hole is aligned with the location of the stud when the audio and/or indicators provide the indication irrespective of the angle at which the wall engaged back surface of the housing is oriented with respect to the wall.

**[0007]** These and other objects, features, and characteristics of the present disclosure, as well as the methods of operation and functions of the related elements of structure and the combination of parts and economies of manufacture, will become more apparent upon consideration of the following description and the appended claims with reference to the accompanying drawings, all of which form a part of this specification, wherein like reference numerals designate corresponding parts in the various figures. It is to be expressly understood, however, that the drawings are for the purpose of illustration and description only and are not intended as a definition of the limits of the disclosure.

### BRIEF DESCRIPTION OF THE DRAWINGS

**[0008]** FIG. 1A depicts an exemplary front view of a stud sensing/stud detecting apparatus.

**[0009]** FIG. 1B is a schematic illustration of a stud sensing circuitry included in the stud sensing apparatus that enables locating a stud according to one or more embodiments of the present disclosure.

**[0010]** FIG. 2 illustrates a shield electrode according to one or more embodiments.

**[0011]** FIG. 3 illustrates two interdigitating electrodes according to one or more embodiments.

**[0012]** FIG. 4 is an exemplary graph depicting signals corresponding to two electrodes according to one or more embodiments.

**[0013]** FIG. 5 is a wall depth table according to one or more embodiments.

**[0014]** FIG. 6 illustrates two electrodes forming a substantially circular configuration according to one or more embodiments.

**[0015]** FIG. 7 illustrates two electrodes forming a substantially circular configuration according to one or more embodiments.

**[0016]** FIG. 8 illustrates two electrodes forming a substantially circular configuration according to one or more embodiments.

[0017] FIG. 9 illustrates two electrodes forming a substantially circular configuration according to one or more embodiments.

[0018] FIG. 10 illustrates arrays of substantially square electrodes forming various structures according to one or more embodiments.

[0019] FIG. 11 is a wall depth table according to one or more embodiments.

[0020] FIG. 12 illustrates various examples of electrodes in substantially triangular patterns and other patterns according to one or more embodiments.

[0021] FIG. 13 is a graph illustrating a progression of overlapping area of a substantially triangular capacitive plate according to one or more embodiments.

[0022] FIG. 14 is a graph illustrating a progression of overlapping area of non-rectangular capacitive plates according to one or more embodiments.

[0023] FIGS. 15-24 illustrate various views of a housing of a stud sensor according to one or more embodiments.

[0024] FIG. 25 illustrates an electronic hardware block diagram according to one or more embodiments.

[0025] FIG. 26 illustrates an electrode connection diagram according to one or more embodiments.

[0026] FIG. 27 illustrates an electrode connection diagram according to one or more embodiments.

[0027] FIG. 28 illustrates a firmware or software flowchart according to one or more embodiments.

[0028] FIG. 29 illustrates a method for locating a stud with a stud sensor according to one or more embodiments.

[0029] FIG. 30 depicts an exemplary front view of a stud sensing/stud detecting apparatus.

[0030] FIG. 31 illustrates the basic concept of metal detection using an inductor.

[0031] FIG. 32 illustrates an L-C resonator, also sometimes referred to as an L-C tank.

[0032] FIG. 33A illustrates the basic components of an inductance to digital converter.

[0033] FIG. 33B illustrates an inductance to digital converter connected to an L-C resonator.

[0034] FIG. 34 illustrates a prior art wire and core inductor.

[0035] FIG. 35 illustrates one layer of a printed circuit board with an exemplary embodiment of an inductive coil thereon.

[0036] FIG. 36 illustrates another layer of a printed circuit board with an exemplary embodiment of an inductive coil thereon.

[0037] FIG. 37A illustrates the printed circuit board with the inductive coils and electrodes.

[0038] FIG. 37B illustrates an exemplary embodiment of cutouts in an electrode configuration.

[0039] FIG. 38 illustrates an electronic hardware block diagram.

[0040] FIG. 39 illustrates an electrode and inductive coil connection diagram.

[0041] FIG. 40 illustrates a firmware or software flowchart according to one or more embodiments

parts are joined or operate together either directly or indirectly, i.e., through one or more intermediate parts or components, so long as a link occurs. As used herein, “directly coupled” means that two elements are directly in contact with each other. As used herein, “fixedly coupled” or “fixed” means that two components are coupled so as to move as one while maintaining a constant orientation relative to each other.

[0043] As used herein, the word “unitary” means a component is created as a single piece or unit. That is, a component that includes pieces that are created separately and then coupled together as a unit is not a “unitary” component or body. As employed herein, the statement that two or more parts or components “engage” one another shall mean that the parts exert a force against one another either directly or through one or more intermediate parts or components. As employed herein, the term “number” shall mean one or an integer greater than one (i.e., a plurality).

[0044] Directional phrases used herein, such as, for example and without limitation, top, bottom, left, right, upper, lower, front, back, and derivatives thereof, relate to the orientation of the elements shown in the drawings and are not limiting upon the claims unless expressly recited therein.

[0045] As used herein, the use of the term “stud” may refer to any hidden object behind the surface of a wall structure, including but not limited to a stud, an alternating current (AC) line, etc. As used herein, the use of the term “wall structure” or “wall” may refer to any surface such as a wall, floor, ceiling, roof, etc. As used herein, the use of the term “substantially circular” is not limited to a circle. Rather, this term refers to circles, ovals, or other rounded shapes. In addition, the term refers to multi-sided shapes approximating a circle. For example, the term refers to octagons or other multi-sided shapes with even more sides than eight. As used herein, the use of the term “square” may refer to square, substantially square, rectangular, or substantially rectangular. As used herein, the use of the term “diamond” may refer to diamond or substantially diamond in shape. As used herein, the use of the term “pyramid” may refer to pyramid or substantially pyramid in shape.

[0046] Current stud sensing devices in the market tend to utilize a single square or rectangular shaped electrode (also referred to herein as a stud sensor). Such stud sensing devices may work if a user moves the stud sensor in a linear and horizontal fashion along a surface of a wall structure. However, a human’s arm does not always move accurately in a linear line. Rather, a human’s arm often moves in an arc like shape, or in another non-linear fashion, especially when the arm is fully stretched out. For example, if a person is reaching far up on a wall structure to try to locate a stud to hang a painting, the person’s arm may move in an arc like fashion. Oftentimes people do not maintain the stud sensors in a perfectly vertical orientation, and moreover do not move in a linear and horizontal fashion.

[0047] Various embodiments according to the present disclosure utilize electrodes that form substantially circular configurations (as defined herein). The use of a substantially circular configuration for the electrodes provisions a user to approach the stud with the stud sensor at an angle, arc or in a non-linear fashion. A stud locating indicia on the housing will enable the user to identify the location of a predetermined location on the stud (e.g., the edge of the stud, the center of the stud, or both) when the sensors (cooperating

#### DETAILED DESCRIPTION OF EXEMPLARY EMBODIMENTS

[0042] As used herein, the singular form of “a”, “an”, and “the” include plural references unless the context clearly dictates otherwise. As used herein, the statement that two or more parts or components are “coupled” shall mean that the

with one or more processors and audio and/or visual indicators) identify that the predetermined location on the stud has been reached. For example, the indicia on the housing, in one embodiment, is simply a marker hole in the housing. In another embodiment, the indicia may comprise a visual display on the housing, indicating a location corresponding to a feature (e.g., edge or center) of a stud.

**[0048]** In the embodiment where a hole is used as the indicia, the hole is substantially centered within the substantially circular configuration of the electrodes. In this embodiment, because the marker hole is equally spaced from all positions on the edge or perimeter of the electrodes, the marker hole will always be located at a predetermined location with respect to the stud, irrespective of the direction or angle the stud is reached from. This will be described in greater detail below. Just for example, in one embodiment, a substantially circular and/or interdigitating sensor configuration can have a diameter of about 2.0", or in one embodiment a diameter in the range of 1.5" to 2.5" and in yet another embodiment, a diameter in the range of 1.0" to 3.0". A diameter of 1.5" corresponds to the width of certain stud types (along its edge) that would normally engage with (or be immediately behind) the dry wall. Thus, in one example for a circular sensor with a diameter of 1.5", if the hole through the housing is centered between the sensors, the center of the hole will essentially be 0.75" from the perimeter of the sensor(s) in all directions. Thus, if a back surface of a housing of the sensing apparatus (also referred to herein as a stud finding device, or simply stud finder) is slid across the wall surface in any direction, then, when the perimeter of the substantially circular configuration of the sensors first reaches the edge of a stud underlying the wall surface, the center of the hole will be positioned 0.75" from the stud edge (or substantially centered with that particular stud type). It must be appreciated that that this will be true regardless of whether the stud finder's housing is moved perfectly horizontally along the wall surface (e.g., perpendicular to the stud), at a 45 degree angle or less with respect to the stud, or optionally at any angle of approach to the stud.

**[0049]** FIG. 1A depicts an exemplary front view of a stud sensing apparatus **100** (also referred to herein as a stud detecting apparatus) according to one embodiment of the present disclosure. The stud sensing apparatus **100** is configured to locate a stud using circuitry **10** illustrated in FIG. 1B. The stud sensing device **100** (referred to hereinafter as stud finder) is configured to facilitate a user to locate a stud without having to align the device **100** in a perfect vertical orientation, or moving the device **100** in a perfect linear and horizontal fashion. In some embodiments, and as shown in FIG. 1B, the stud finder includes one or more of, a processor **12**, electronic storage **14**, and a capacitive sensor **22** (also referred to herein as a stud sensor). By one embodiment, each of the processor **12**, the capacitive sensor **22**, and the electronic storage **14** may be coupled to a user interface **20**. The user interface **20** provisions for instance, functions such as tuning the parameters of the capacitive sensors and the like. Details regarding this are described later with reference to FIG. 25. In some embodiments, processor **12**, electronic storage **14**, and the capacitive sensor **22** may reside in the same housing. In some embodiments, a microcontroller may be included in the same housing within which capacitive sensor **22** resides, and may be communicatively coupled with processor **12**, electronic storage **14**, and capacitive

sensor **22**. In some embodiments, capacitive sensor **22** may reside within a handheld housing.

**[0050]** The capacitive sensor(s) **22** may comprise two or more electrodes that may or may not be interdigitating. Moreover, the stud finder **100** may further comprise one or more processors. The one or more processors may be communicatively coupled with the capacitive sensor (**22**).

**[0051]** Processor **12** may be configured to provide information processing capabilities in stud finder **100**. As such, processor **12** may comprise one or more of a digital processor, an analog processor, a digital circuit designed to process information, an analog circuit designed to process information, a state machine, and/or other mechanisms for electronically processing information. Although processor **12** is shown in FIG. 1B as a single entity, this is for illustrative purposes only. In some embodiments, processor **12** may comprise a plurality of processing units. These processing units may be physically located within the same device (e.g., a server or the housing within which capacitive sensor **22** resides), or processor **12** may represent processing functionality of a plurality of devices operating in coordination (e.g., a server, computing device and/or other devices.)

**[0052]** Furthermore, processor **12** can be configured via machine-readable instructions **24** to execute one or more computer program components. The one or more computer program components may comprise one or more of a calculating stud location component **26**, a result reporting component **28**, and/or other components. Processor **12** may be configured to execute components **26** and/or **28** by software; hardware; firmware; some combination of software, hardware, and/or firmware; and/or other mechanisms for configuring processing capabilities on processor **12**.

**[0053]** It should be appreciated that although components **26** and **28** are illustrated in FIG. 1B as being co-located within a single processing unit, in embodiments in which processor **12** comprises multiple processing units, one or more of components **26** or **28** may be located remotely from the other component. The description of the functionality provided by the different components **26** and **28** described below is for illustrative purposes, and is not intended to be limiting, as any of components **26** and **28** may provide more or less functionality than is described. For example, one or more of components **26** and **28** may be eliminated, and some or all of its functionality may be provided by other components. As another example, processor **12** may be configured to execute one or more additional components that may perform some or all of the functionality attributed below to one of components **26** and/or **28**.

**[0054]** In some embodiments, calculating stud location component **26** may be configured to calculate a stud location by measuring a change in capacitance from a fixed capacitance of a wall structure as the stud sensor is moved along a surface of the wall structure, as known in the art. Result reporting component **28** may be configured to report a result relating to a location of a stud.

**[0055]** In one embodiment, the stud sensor **22** uses capacitive sensing electronics to locate the center of studs and joists through a drywall or other common building materials and provides to a user an indication, either visually and/or audibly once a detection is made. The thickness of the building materials where stud is located may be 0.5", 0.75", 1" and up to 1.5" or more (or less than 0.5"), as known in the art. Use with any other suitable thicknesses is contemplated.

By one embodiment, the stud detecting device of the present disclosure may also detect AC lines behind the surface of the drywall or other common building materials. Those AC lines carry the electrical power being delivered to homes and businesses. AC voltages may be in the range of 100-240V and AC frequencies may be in the range of 50-60 Hz. Use with lower and higher frequencies is contemplated.

**[0056]** Stud sensor **22** detects a capacitive change to a sensor when a stud is present behind the surface of a wall structure. In some embodiments, “charge transfer in self mode” technology is the capacitance measurement technology used to measure a change in capacitance based upon a fixed capacitance of the wall structure. There are several companies that produce “charge transfer” integrated circuit (IC) chips for user applications including Texas Instruments’ CapTIvate technology. .

**[0057]** “Self-mode” refers to the external capacitance change relative to earth ground. There are three different capacitors: a Vreg capacitor (not shown), a sampling capacitor (not shown), and an external unknown capacitor(s) (the first and second electrodes of the capacitive sensor **22**, as shown in FIG.1B) in hardware to implement the charge transfer technology. During the charge phase, the capacitance charge stored on the Vreg capacitor is used to charge the external unknown capacitance. Then a transfer phase begins, and the charge from the external capacitance is transferred to a sampling capacitor. In the meantime the Vreg capacitor is recharged by a DC linear voltage regulator. These charge and transfer phases are repeated until the sampling capacitor is charged to a preset amount.

**[0058]** In some embodiments according to the present technology, the external capacitance is the electrode’s capacitance change when there is stud or similar structure present. The hardware to implement this capacitance measurement is part of the peripheral of the microcontroller. The microcontroller’s charge transfer engine settings are configured in software to provide high sensitivity of the system.

**[0059]** In one embodiment, the housing **101** (FIG. 1A) is provided with an indicia thereon to advise the user where, in relation to the housing the identified attribute of the located stud (edge or center) is located. For example, the indicia can be a pointer on the housing, an LED display on the housing, or simply a hole through the housing (as in the illustrated embodiment). Further details regarding the housing and the associated components of the stud finder **100** are described later at least, with reference to FIG. **15**.

**[0060]** By way of a non-limiting example, FIG. **2** illustrates an optional first shield electrode **202** (solid shield plane) according to one or more embodiments. In one embodiment, the shield electrode **202** is substantially circular (like the capacitive sensor electrodes), and in one embodiment the shield electrode **202** has an outer diameter that is larger than the outer diameter of the substantially circular sensor electrodes that for the capacitive sensor **22**. In another embodiment, the shield electrode **202** has an outer configuration that is not substantially circular. A hole **204** (or center marking channel) is provided through the center of first shield electrode **202**. In some embodiments, the hole (or center marking channel) through the center of first shield electrode **202** may be aligned, or at least partially aligned, with a back hole **1514** that is disposed on a back side of the housing (e.g., through the back half of a clam shell housing) of the stud finder (see FIG. **15**). In some embodiments the hole **204** may also extend through the front of the housing

(e.g., through a front half of a claim shell housing). In one embodiment, the hole at the front of the housing may be larger (or smaller) than the hole at the back of the housing. In one embodiment, the hole **204** extends through the housing and through the shield electrode (as well as the substantially circular and/or interdigitating electrodes forming the capacitive sensor as will be described). As such, the hole is substantially centered with respect to the periphery of these electrodes. The hole is configured to be aligned with an edge of a stud, or in some embodiments with the center of a stud, when an audio and/or visual indicator reports a result related to a location of a stud. For example, the audio indicator can take the form of a speaker, vibrator, or other noise maker that emits a sound when the edge (and/or center) of a stud is reached or located. In addition, or alternatively, a visual indicator such as an LED, LCD, or other visual indicator can provide a visual indication, when the edge (and/or center) of a stud is reach or located. A pencil or pen may be inserted through hole **204** to mark the wall surface at a location of the wall behind which a stud has been detected. In another embodiment (not illustrated), rather than a hole (and instead of the user using a pen or pencil to mark the wall surface), the central region of the housing (where the hole **204** is located) can instead be provided with a spring biased button. The button has a finger engaging surface at the front side of the housing, and an extendable pin or pointed projection that is normally withdrawn inside the housing and can be forced rearwardly beyond the back surface of the housing, against the spring bias of the button when the button is depressed by a user, to engage the wall surface to create a small hole or mark on the wall surface. The small hole or mark created by the pin or pointed projection will correspond to the center of the stud, when a stud has been detected.

**[0061]** By one aspect of the present disclosure, the first shield electrode **202** is disposed on a back side (placed in apposition or substantially in apposition with a wall structure) of a printed circuit board (PCB) **206**. Moreover, the first shield electrode **202** is driven at a same potential as the two interdigitating electrodes **302** and **304** of FIG. **3**. The utility of the shield electrode as well as its relative positioning with respect to the PCB and the interdigitating electrodes is described next with reference to FIG. **3**.

**[0062]** In the embodiment where a hole **204** is used as the indicia, the hole is substantially centered within the substantially circular configuration of the electrodes. This can be appreciated from the configurations shown in FIGS. **6-9**. In these embodiments, because the marker hole **204** is equally spaced from all positions on the edge or perimeter of the electrodes, the marker hole will always be located at a predetermined location with respect to the stud, irrespective of the direction or angle the stud is reached from. For instance, the stud finder need not be held perfectly in a vertical fashion in order to detect the stud. Even if the stud finder is disposed at an angle with respect to the wall, the stud finder of the present disclosure enables accurate detection of the stud due to the configuration of the capacitive sensors described herein. Just for example, in one embodiment, a substantially circular sensor configuration can have a diameter of 1.5" (which corresponds to the width of certain stud types along its edge that would normally engage (or be immediately behind) the dry wall. If the hole **204** though the housing and centered between the sensors is centered, the center of the hole will essentially be approximately 0.75"

from the perimeter of the sensors in all directions. Thus, if the stud sensor housing back surface is slid across the wall surface in any direction, when the perimeter of the substantially circular configuration of the sensors first reaches the edge of a stud underlying the wall surface, the center of the hole will be positioned 0.75" from the stud edge (or substantially centered with that particular stud type). This will be true whether the stud finder housing is moved perfectly horizontally along the wall surface (e.g., perpendicular to the stud), at a 45 degree angle or less with respect to the stud, or optionally any angle of approach to the stud.

**[0063]** FIG. 3 illustrates two interdigitating electrodes according to one or more embodiments. The term "interdigitating" as used herein is defined to mean folded or locked together. This may mean, for example, that one electrode may not be moved relative to another electrode on at least one axis. The two interdigitating electrodes include first electrode 302 and second electrode 304. In some embodiments, the electrodes may not be interdigitating. In one embodiment, there is a gap 306 formed between first electrode 302 and second electrode 304, and an outer perimeter 312. In some embodiments, gap 306 may be approximately 0.2 mm, however, any other suitable values are contemplated. For instance, the gap 306 may be in the range from 0.05 mm to 0.3 mm, and in another embodiment, in the range 0.15 mm to 0.25 mm. Note that the gap 306 provides insulation between the first electrode 302 and the second electrode 306.

**[0064]** By one embodiment of the present disclosure, it is envisioned that a second shield electrode 308, that is substantially ring-shaped, may be included in the stud sensor. Accordingly, the first electrode 302, second electrode 304, first shield electrode 202, and second shield electrode 308 form a capacitive sensor. The sensor design choice provides sufficient sensitivity and minimizes noise from parasitic capacitance. By one embodiment, the interdigitating electrodes are disposed on a top layer of PCB 206, and surrounded at its periphery by second shield electrode 308. The first shield electrode 202 can be disposed by one embodiment, across the bottom layer of the PCB. The first shield electrode 202 and second shield electrode 308 are electrically coupled and/or communicatively coupled with respect to each other and with respect to first electrode 302 and second electrode 304. There is a gap 310 between the electrodes (first electrode 302 and second electrode 304) and second shield electrode 308. In some embodiments, gap 310 may be approximately 0.8 mm, however, any other suitable values are contemplated. For instance, the gap 310 may be in the range 0.5 mm to 0.8 mm, and in one embodiment, in the range of 0.6 mm to 0.7 mm. The combination of charge transfer in self mode technology with an interdigitating electrode sensor enables accurate detection of stud centers on thicker walls over other stud finders on the market. An accelerometer, humidity detector, and temperature detector may provide increased reliability.

**[0065]** The shield electrodes disclosed herein are optional, and can be omitted from the embodiments described. When they are provided, they provide various functionality to the stud finder. For example, in some embodiments they can reduce noise because they are the ground plane of the PCB. Secondly, the shield electrodes are driven at the same potential as first electrode 302 and second electrode 304. This driven shield minimizes the parasitic capacitance and increases the sensor's sensitivity.

**[0066]** In some embodiments, the combination of first electrode 302 and second electrode 304 generate a total of two signals that indicate a change in capacitance when there is stud behind the surface of the wall structure and the stud is in proximity with the capacitive sensor. The signal value will drop gradually when the electrodes 302 and 304 (i.e., together the capacitive sensor) passes over the stud and gradually increase after the capacitive sensor passes the stud as shown in FIG. 4. The software and/or firmware in a microcontroller can be configured to continuously monitor the signal values. The changes in value is recognized by software and/or firmware and used to determine the presence and/or location of a stud.

**[0067]** By way of a non-limiting example, FIG. 4 illustrates two electrodes' signal graph 400 according to one or more embodiments. The horizontal axis 402 represents the number of samples of capacitance taken as capacitive sensor 22 travels across a surface of a wall structure (from left to right in this case). The vertical axis 404 does not have units, but represents a relative change in capacitance as capacitive sensor 22 travel across the surface. Waveform 406 represents a signal reading from first electrode 302. Waveform 408 represents a signal reading from second electrode 304. The signals are at their lowest points at stud center line 410. When the waveforms reach this low point, capacitive sensor 22 is centered over the stud. For instance, referring to FIG. 1B, when sweeping capacitive sensor 22 from left to right, for example, the electrode to the sensor's right (i.e., the electrode labeled as the 2<sup>nd</sup> electrode) would be activated when encountering a stud. Subsequently, the electrode to the sensor's left (i.e., the electrode labeled as the 1<sup>st</sup> electrode) would be activated as the electrode to the sensor's right is being deactivated.

**[0068]** The number and area of the electrodes are selected to provide sufficient signal strength to detect a stud through the maximum specified thickness of wall based on the capacitance equation:

$$C = \epsilon \times A / d \quad \text{Equation 1}$$

where E is the dielectric constant, A is the area of contact of sensor 22 (i.e., the circular area of the capacitive sensor 22) with a wall structure, and d is the distance between the capacitive sensor and the stud (or the wall thickness in some embodiments).

**[0069]** In some embodiments, the sensor is designed in substantially circular shape for symmetry. One aspect of the substantially circular shape, as explained above, is that the signals (see FIG. 4) are tolerant of the angle of the movement of capacitive sensor 22. One embodiment, the capacitive sensor 22 will work best when the user approaches a stud at an angle of less than 45° (movement by the user). This is because at greater angles, the two electrodes may approach the stud at the same time (e.g., if the stud sensor approached the stud at 90°, with the top part of the housing moving into/toward the stud). Of course, this angle can be engineered and designed as desired.

**[0070]** FIG. 5 is a wall depth table according to one or more embodiments. In capacitance equation 1 above, the area of the combination of two electrodes is in direct relationship to capacitance. This table defines, in some embodiments, the minimum round area of two electrodes with respect to wall depth that will generate good and reliable detection capacitance change results. The numbers

in this wall depth table are merely exemplary in nature and not intended to be limiting. Other values are envisioned.

[0071] FIG. 6 illustrates two interdigitating electrodes forming a substantially circular configuration according to one or more embodiments. A first electrode 602 and a second electrode 604 separated by an interface 606. A hole 204 (or 1514, see FIG. 15) is provided through the electrodes (or at the interface between the electrodes) as illustrated and discussed herein. A yin-yang or s-shaped pattern may be formed in the embodiment of FIG. 6. First electrode 602 and second electrode 604 may meet at a variety of different curves and/or line segment(s). The substantially circular configuration formed by the two electrodes of FIGS. 6-9 may have a diameter ranging between approximately 1" to 3". However, other values are contemplated. Moreover, in one embodiment, the diameter of the shield electrode 202 is greater than the diameter of the circular configuration formed by the first electrode 602 and the second electrode 604. For instance, the diameter of the shield in one embodiment is in the range 1.5" to 3.5". In another embodiment, the shield electrode has a diameter that is smaller than the first electrode

[0072] FIG. 7 illustrates two electrodes forming a substantially circular configuration according to one or more embodiments. A first electrode 702, and a second electrode 704 meet at a gap 706 and a hole 204 as discussed herein. First electrode 702 and second electrode 704 are each in the shape of a semi-circle, or a substantially semi-circular shape. Interface 706 is in the form of a line segment with hole 204 there through. The configuration of the electrode illustrated in FIG. 7 is not interdigitating.

[0073] FIG. 8 illustrates two interdigitating electrodes forming a substantially circular configuration according to one or more embodiments. A first electrode 802 and a second electrode 804 meet at interface or gap 806 and comprises a hole 204 there through as discussed herein. A saw-tooth or zig-zag pattern is formed by the interface for the embodiment of FIG. 8. Interface 806 has three line segments with the central line segments having hole 204 there through.

[0074] FIG. 9 illustrates two interdigitating electrodes forming a substantially circular configuration according to one or more embodiments. A first electrode 902 and a second electrode 904 meet at interface or gap 906 and comprises hole 204 as discussed herein. As can be seen in FIG. 9, the interface between first electrode 902 and a second electrode 904 comprises a plurality of curved lines. All other suitable patterns are contemplated but are not shown herein for the sake of brevity.

[0075] Interdigitating electrodes provide higher sensitivity than non-interdigitating electrodes. If there are N number of electrodes, the ratio of each electrode's area to the whole area of the substantially circular capacitive plate is 1:N in some embodiments. In one embodiment, the shape of a given electrode is the mirror image of the other electrode within the circular area; those electrodes are interlocking (interdigitating) in some embodiments. However, it must be appreciated that the N electrodes that are interdigitated form a substantially circular configuration.

[0076] FIG. 10 illustrates arrays of substantially square two-dimensional electrodes forming various structures according to one or more embodiments. The diamond pattern comprises multiple square electrodes arranged in an N×N array and formed in substantially diamond shape. The pyramid pattern comprises multiple square electrodes

arranged in N×M array and formed in a substantially pyramid shape. The configuration of electrodes enables capacitive sensor 22 to be omnidirectional. Stud sensor 22 may be moved at any angle and still detect a predetermined or desired location of stud (e.g., the edge or center) irrespective of the angle at which the wall engaged back surface of the housing of capacitive sensor 22 is oriented with respect to the wall.

[0077] Additionally, based on the location of the electrodes and changes in electric potential of the electrodes, stud sensing device 100 may indicate the orientation of a stud. These attributes may also apply to other embodiments, such as the embodiments of FIGS. 6-9. For example, as described in the U.S. Provisional Application No. 62/354,176, (and with reference therein to FIGS. 5 and 6A), the electrodes overlapping the stud area constantly changes due to the shape of the electrodes as the stud finder is moved across the wall. Accordingly, as the capacitance of certain electrodes (within the pyramid or diamond style configuration of FIG. 10) changes, the stud finder may be configured to estimate the orientation of the stud.

[0078] By one embodiment, the substantially circular configuration of electrodes enables capacitive sensor 22 to be omnidirectional. In contrast, as a rectangular electrode crosses over a stud, the overlap area with respect to the electrode and the stud will not increase at a predictable rate if the rectangular electrode is not aligned vertically. For example, a corner of the electrode may first overlap a stud if the electrode is not aligned vertically with respect to a wall structure. Providing a substantially circular configuration overcomes this problem and allows for the sensor to not be aligned vertically and to be moved in a non-linear fashion.

[0079] FIG. 11 is a wall depth table according to one or more embodiments. This table defines, in some embodiments, the minimum square electrode area of a square electrode with respect to wall depth that will generate clean and reliable detection capacitance change results. The numbers in this wall depth table are merely exemplary in nature and not intended to be limiting. Other values are envisioned.

[0080] FIG. 12 illustrates various examples of electrodes in substantially triangular patterns and other patterns according to one or more embodiments. These patterns were discussed in U.S. Provisional Application No. 62/354,176, filed on Jun. 24, 2016 and titled "STUD FINDER," the content of which is incorporated herein in its entirety by reference. The patterns comprise one or multiple modified forms of substantially triangular or substantially rectangular electrodes. During operation, the part of the electrode overlapping the stud area is changing due to the shape of electrode. The changing area generates a direct proportional capacitance change. Moreover, the relationship between the shape and overlapping area is explained in FIGS. 6A and 6B of the '176 provisional patent application.

[0081] FIG. 13 is a graph illustrating a progression of overlapping area of a substantially triangular capacitive plate according to one or more embodiments. FIG. 13 corresponds to FIG. 6A of the '176 provisional patent application and was described therein.

[0082] FIG. 14 is a graph illustrating a progression of overlapping area of non-rectangular capacitive plates according to one or more embodiments. FIG. 14 corresponds to FIG. 6B of the '176 provisional patent application and was described therein.

[0083] FIGS. 15-24 illustrate various views of designs of a housing of capacitive sensor 22 according to one or more embodiments. In some of the figures, back hole 1514 is depicted as smaller than hole 204. However, in some embodiments back hole 1514 is larger than hole 204 and may be located at the front of housing 1500 with hole 204 being smaller and located at the back of housing 1500. FIGS. 15-19 differ aesthetically with respect to FIGS. 20-24, as can be seen in the figures. In some embodiments, the sensor and electronic control circuits are laid out in one PCB and the top side of PCB is enclosed in a plastic housing 1500. The housing is designed to be user-friendly and ergonomic. The back of the PCB is covered in an overlay material made of adhesive-backed film with a thickness of approximately 0.005". However, other values are envisioned. The overlay material may or may not include labeling. This material is better than the felt pads used on the most current stud finders in the market because it provides very smooth movement and reduces the assembly parts. Furthermore, the use of the overlay material also eliminates an air gap that is created by using multiple smaller pads, thus increasing dielectric coupling. Because the product slides smoothly on the wall, it can start and stop quickly so the user gets an accurate location of a stud center.

[0084] In some embodiments, housing 1500 includes power button 1502, battery compartment 1504, LEDs 1506, 1508, and 1510, AC detector LED 1512, hole 204, and back hole 1514. In some embodiments, hole 204 may have a diameter greater than that of back hole 1514; however, this need not be the case. In some embodiments, hole 204 may have a diameter less than that of back hole 1514. In some embodiments, hole 204 may have a diameter equal to that of back hole 1514. In some embodiments, hole 204 may be the hole through the center of the capacitive plate formed from first electrode 302 and second electrode 304 and may be located at the back of housing 1500. The back of housing 1500 is the face of the housing that is put in apposition with a surface of a wall structure. Hole 204 may go through first electrode 302, second electrode 304, and form an opening in the back of housing 1500 that may lead to a surface of a wall structure. In some embodiments, hole 1514 may be the hole through the center of the capacitive plate formed from first electrode 302 and second electrode 304. In some embodiments, hole 204 may be the back hole and what was referred to as back hole 1514 may be the hole in the front of housing 1500. The front of housing 1500 is the part of housing 1500 that is opposite to the back of housing 1500. The front of housing 1500 is not put in apposition with a surface of a wall structure. The user may view the front of housing 1500 while sweeping the back of housing 1500 across a surface of a wall structure. The front of housing 1500 may include elements such as LEDs and a power button in some embodiments. Battery compartment 1504 may be configured horizontally (as in FIG. 15) or vertically (as in FIG. 20). A hole (1514) formed through the housing 1500 may be centered or substantially centered with respect to the hole (204) formed between the capacitive plates (i.e., the first electrode 302 and second electrode 304).

[0085] Another feature of housing 1500 is the power button's location and design, which assists the user in holding the housing 1500 evenly on a wall structure, thereby generating a clean signal. Yet another feature standing out from the current stud finder products is the thin profile of the body which can be easily put into user's pocket.

[0086] As mentioned previously, an opening (hole 204) in the center of sensor 22, and correspondingly the opening 1514 on the housing of the stud finder are intended for the user to draw a mark on the wall through the opening when the stud is detected. In doing so, encourages the user to mark the center of the detecting electrodes instead of the traditional linear offset marking channel, eliminating some potential for error.

[0087] In some embodiments, when the housing 1500 is swept across the surface of a wall structure, LED 1506 lights up (i.e., activated), when a stud is proximate to capacitive sensor 22 and to the left of the center of the sensor (the electrodes) of capacitive sensor 22. When sweeping the housing 1500 across the surface of a wall structure, LED 1510 lights up when a stud is located approximately at the center of the sensor of capacitive sensor 22 and to the right of the center of the sensor of capacitive sensor 22. At that point, the user can use a pencil or pen to mark the wall surface through the hole 204, which should be aligned with the center of the stud at that point. When sweeping housing 1500 across the surface of a wall structure, LED 1508 lights up when a stud is approximately at the center of the sensor of capacitive sensor 22. Again, at that point, the user can use a pencil or pen to mark the wall surface through the hole 204, which should be aligned with the center of the stud at that point. Other forms of reporting the location of a stud (or more specifically, a position on the stud such as the edge or center) are contemplated, such as audio signals, digital readouts, vibration, etc. AC detector LED 1512 lights up when an AC line is located. Audio or graphical display may also be used to indicate the detection of an AC line. Other forms of reporting the location of an AC line are contemplated.

[0088] FIG. 16 illustrates a back view of housing 1500, whereas FIG. 17 depicts an isometric view of the stud finder 100. Moreover, FIGS. 18 and 19 depict a side view, and a trimetric view of the stud finder, respectively. Referring to FIG. 16, tab 1600 may be actuated to open battery cover 1602 of battery compartment 1504 (as shown in FIG. 17). In some embodiments, the back hole may be hole 204. In some embodiments, the back hole may be back hole 1514 and may be smaller than hole 204. This holds true for all the figures in some embodiments.

[0089] FIG. 20 illustrates a front view of another design of housing 1500. In some embodiments, housing 1500 additionally includes a power on LED 2000, a power button 2002, and a cover 2004 to a battery compartment that is configured vertically instead of horizontally.

[0090] FIG. 21 illustrates a back view of the design of housing 1500 of FIG. 20.

[0091] Hole 1514 and cover 2004 to the battery compartment are shown. FIGS. 22 and 23 depict isometric and trimetric views of the stud finder of FIG. 20, whereas FIG. 24 illustrates a side view of the design of housing 1500 of FIG. 20.

[0092] FIG. 25 illustrates an electronic hardware block diagram 2500 according to one or more embodiments. In some embodiments, electronic hardware block diagram 2500 may comprise a microcontroller 2502, a charge transfer engine 2504, electrodes 2506 (the sensor of capacitive sensor 22), an AC detection module 2508, a battery/voltage regulator 2510, a buzzer/LEDs (that may be part of user interface 2514), a programming connector 2516, a serial communication block 2518, and/or other elements. Micro-

controller's **2502** integrated charge transfer engine **2504** may use charge transfer technology to measure the capacitance change in electrodes **2506** (the sensor of capacitive sensor **22**) because each electrode is a self-capacitive sensor in some embodiments. In some embodiments, each electrode including the shield node is mapped to the charge transfer engine's **2504** port pin as shown in FIGS. **26** and **27**. The control of the charge and transfer phases and the conversion rate are configured in charge transfer engine **2504** and controlled by charge transfer engine **2504**. Microcontroller **2502** scans the electrodes in parallel. This capability reduces the scan time and power consumption. In some embodiments, charge transfer engine **2504** may be integrated in microcontroller **2502**. In some embodiments, charge transfer engine **2504** may be outside of microcontroller **2502**.

**[0093]** In some embodiments, as indicated, a buzzer and visual indicators such as LEDs (or other indicators) may be part of user interface **2514**. A buzzer may sound and a colored visual indicator such as red light on the housing may light up when the center of a stud is detected. Other colored visual indicators such as, for example, a yellow light may light up when approaching or leaving the stud area. When an AC line is detected, a buzzer may sound and a colored visual indicator such as red light on the product may light up to indicate there is AC line within a specified distance from the device. Programming connector **2516** connected to microcontroller **2502** may enable a program on the PCB to be updated using a computer. Serial communication block **2518** may enable microcontroller **2502** to send and receive the data through a serial port on microcontroller **2502**.

**[0094]** By one embodiment, because of the fast electrode scanning time and low power consumption, capacitive sensor **22** is able to be powered by low power sources such as, for example, 2 AAA batteries. The small size of the batteries allows housing **1500** to be small and portable. In some embodiments, the hardware design may use surface-mount components. This reduces assembly time and cost. Because, in some embodiments, there are no through-hole components on the back side of the PCB, the overlay material may be directly applied over the back of the PCB without the need for another smooth plate. This further reduces assembly time and cost, and also allows housing **1500** to be small and portable.

**[0095]** Firmware of the stud finder may run on microcontroller **2502**. The firmware may comprise, in some embodiments, three main software segments: charge transfer engine configuration code, stud sensor application code, and data communication code.

**[0096]** The charge transfer engine configuration code sets the capacitance mode to SELF mode; assigns all the sensor elements to the appropriate port pins on microcontroller **2504**; and optimizes sensor **22** tuning parameters such as conversion gain, conversion count, and scan time to create high sensitivity for stud detection. It scans the sensors in parallel, which reduces operating time and saves battery power. It also automatically calibrates the sensor data so the system does not require a user to wait for a few seconds for calibration after powering up.

**[0097]** In some embodiments, the stud sensor application code is designed with an algorithm to detect a stud behind the surface of walls of 0.5" and 0.75" thickness. However, other values (e.g., 1" and 1.5") are also contemplated. During various running cycles, firmware reads in the raw capacitance data from capacitive sensor **22**, smooths out the

noise in the data, and checks the current data against the previous data to look for the data trend direction. In FIG. **4**, it is shown that the stud center is located when the waveforms reach their lowest points. Data moves in a downward trend when approaching a stud and an upward trend when leaving a stud. As soon as the data changes from a downward trend to an upward trend, the firmware will alert the user with a colored visual indicator (or other indicator) such as red light and buzzer sound to indicate a stud is detected. The firmware sets a threshold of the capacitance data value change for different wall thicknesses. If the capacitance data value change does not reach the threshold, it will not be recognized by the software as a valid stud in order to prevent misdetection. This threshold value is also used to predict a wall's thickness.

**[0098]** AC detection circuits send a signal to microcontroller **2502** when an AC line is detected within a given distance range. The firmware (or software) will alert the user with a colored visual indicator (or other indicator) such as red light and buzzer sound to indicate the AC line has been detected.

**[0099]** FIG. **28** illustrates a firmware or software flowchart **2800** according to one or more embodiments. At an operation **2802**, the stud finder can be initialized. This may include adjusting various setting, and performing a setup operation including configuring communication ports and microcontroller **2502**.

**[0100]** At an operation **2804**, the sensor (two electrodes that may be interdigitating, and the shield electrode) of capacitive sensor **22** are initialized. This may include setting up a configuration for the electrodes and changing various settings, parameters, etc. For instance, by one embodiment, the previously described functions performed by the charge transfer engine are performed in this step.

**[0101]** At an operation **2806**, stud data may be initialized by setting at least one capacitance variable to a specified value.

**[0102]** At an operation **2808**, a system refresh is performed so the stud data is read from the two or more electrodes, the data being related to a capacitance behind a surface. This capacitance variable will change as capacitive sensor **22** approaches a stud and a measured capacitance changes. The capacitance variable represents the measured capacitance at a location behind a surface of a wall structure. More specifically, one or more processors modify the capacitance variable as a measured capacitance of the wall structure at a position of the sensor with respect to the wall structure changes, the capacitance variable being directly proportional to the measured capacitance of the wall structure at the position of the sensor.

**[0103]** At an operation **2810**, a stud location is calculated by determining when the waveforms of FIG. **4** reach their lowest point. That is, when the capacitance and capacitance variable(s) reach their lowest value(s). In some embodiments, detecting the location of a stud may include detecting an edge of a stud, a center of a stud, or both. In some embodiments, a picture of an entire stud may be shown. In other words, an array of LEDs may be implemented and only the LEDs that are determined to be above the stud may be illuminated. In this way, a user may see where the middle and/or ends of the stud are located. Alternatively, a single LED may be utilized to indicate when the center of the stud is detected.



[0104] At an operation **2812**, when a stud has been located a result is reported to the user. This may be done in a variety of ways. For example, LEDs, a graphical display, audio, etc. may be used to indicate proximity of a stud or an exact or substantially exact location of a stud. The process then proceeds to operation **2808**. The refresh may be automatic in some embodiments. The refresh may be initiated manually in some embodiments.

[0105] At an operation **2812**, AC line detection is performed as is known in the art.

[0106] At an operation **2816**, AC detector LED **1512** lights up if an AC line is detected. Audio or a graphical display may also be used to indicate the detection of an AC line. The process then proceeds to operation **2812**. If no AC line is detected, then the process proceeds to operation **2808**. The refresh may be automatic in some embodiments. The refresh may be initiated manually in some embodiments.

[0107] FIG. **29** illustrates a method **2900** for locating a stud with capacitive sensor **22** configured to locate a stud according to one or more embodiments. Stud sensor **22** comprises housing **1500** and a sensor carried by housing **1500**. The sensor comprises two or more electrodes. Stud sensor **22** further comprises one or more processors communicatively and/or electrically coupled with the two or more electrodes. In some embodiments, the two or more electrodes may be interdigitating. The one or more processors are configured by machine-readable instructions to execute computer program components. The computer program components comprise calculating stud location component **26**, result reporting component **28**, and/or other components.

[0108] The operations of method **2900** presented below are intended to be illustrative. In some embodiments, method **2900** may be accomplished with one or more additional operations not described, and/or without one or more of the operations discussed. Additionally, the order in which the operations of method **2900** are illustrated in FIG. **29** and described below is not intended to be limiting.

[0109] In some embodiments, method **2900** may be implemented in one or more processing devices (e.g., a digital processor, an analog processor, a digital circuit designed to process information, an analog circuit designed to process information, a state machine, and/or other mechanisms for electronically processing information). The one or more processing devices may include one or more devices executing some or all of the operations of method **2900** in response to instructions stored electronically on an electronic storage medium. The one or more processing devices may include one or more devices configured through hardware, firmware, and/or software to be specifically designed for execution of one or more of the operations of method **2900**.

[0110] At an operation **2902**, the location of a stud is calculated. In some embodiments, operation **2902** is performed by a processor component the same as or similar to calculating stud location component **26** (shown in FIG. **1B** and described herein).

[0111] At an operation **2904**, results related to a stud location are reported. In some embodiments, operation **2904** is performed by a processor component the same as or similar to result reporting component **28** (shown in FIG. **1B** and described herein).

[0112] In another exemplary embodiment, the stud finder may include a metal detector, as shown by the embodiment of FIG. **30** which illustrates stud finder **101**. Stud finder **101**

may include all of the features, embodiments, and options of stud finder **100**. Additionally, the stud finder **101** includes a metal detection feature. As shown in FIG. **30**, the stud finder **101** includes a metal detection indicator **3000** on its housing **1500**. The metal detection indicator **3000** indicates when a metal object has been detected. Typically the metal object being detected is behind a work surface, wall or other object such that it is not visible. The metal detection indicator **3000** may be an LED which is activated when a metal object is detected. In other embodiments, the metal detection indicator may be more than one LED or the indicator may be comprised of other elements such a light, LCD screen, sound, other display or other indication. In some embodiments, the metal detection indicator may vary depending upon the strength of the metal detection. For example, there may be three LED indicators and an increasing number of LED indicators may be activated as the strength of the detection increases (i.e., one LED is activated when the signal is weak and three LEDs are activated when the signal is strong.).

[0113] A metal object can be sensed by an inductor. FIG. **31** illustrates the basic concept of metal detection with an inductor. As shown in FIG. **31**, there is a conductive metal **3010**. There is also an inductor **3011** with an AC current running through the inductor **3011**. When the inductor **3011** gets close to the conductive metal **3010**, an eddy current is induced in the metal **3010**.

[0114] FIG. **32** illustrates an L-C resonator, or L-C tank **3020**. The L-C resonator includes an inductor and a capacitor, and generates an electromagnetic field. As a metal object, such as the conductive metal **3010**, gets close to the L-C resonator, the magnetic field of the L-C resonator is disrupted. This disruption can be detected.

[0115] FIG. **33A** illustrates the basic components of the inductance to digital converter **3030**. The inductance to digital converter **3030** includes a resonant circuit driver **3031** and a core circuit **3032**. The core circuit **3032** measures and digitizes the sensor frequency and outputs a digital value (digital output). The inductance to digital converter **3030** can be used in a metal detection sensor.

[0116] For example, FIG. **33B** illustrates an inductance to digital converter **3030** connected to an L-C resonator **3020**. The inductance to digital converter **3030** measures and digitizes the signal from the L-C resonator **3020** as it moves near the conductive metal **3010** and outputs a digital signal. The digital signal can be processed by a microcontroller, and the microcontroller and provide an indication of whether the stud finder **101** is near a metal object **3010**. The indication may be activation of indicator **3000**, as discussed above.

[0117] In prior art stud finders, a wire **3040** was wound about a core **3041** to create an inductor, as is shown in FIG. **34**. However, such a configuration may be unduly bulky, difficult to locate in a housing, and prone to breakage.

[0118] In order to alleviate such problems, and provide other advantages, in the stud finder **101** of the present exemplary embodiment, utilizes as an inductor **3011** inductive coils **4100** and **4101** located on a printed circuit board (PCB) **4000** as is shown in FIGS. **35** and **36**. The printed circuit board **4000** has multiple layers of copper conductor alternating with layers of substrate. For example, the printed circuit board **4000** may have four layers. When the printed circuit board **4000** has four layers, first and second electrodes may be on a first layer. This may comprise, for example, any of the first and second electrode structures

shown in any of the embodiments of the present application. For example, electrodes **310** and **304**; **602** and **604**; **702** and **704**; **802** and **804**; or **902** and **904** may be on the first layer of the printed circuit board **4000**. FIGS. **37** and **39** illustrate electrodes **702** and **704**, but the other electrodes may be used similarly.

[0119] FIG. **35** illustrates one layer of the printed circuit board **4000**, a second layer **4002**. The first inductive coil **4100** is printed on a second layer **4002** of the printed circuit board **4000**.

[0120] FIG. **36** illustrates the third layer **4003** of the printed circuit board, upon which the second inductive coil **4101** is disposed.

[0121] As shown, the first and second inductive coils **4100**, **4101** form a circular shape near the outside of the printed circuit board layers **4002**, **4003**.

[0122] The shield layer shown in FIGS. **26** and **27** may be on a fourth layer of the printed circuit board **4000**. Separating the shield layer and the electrodes **310** and **304**; **602** and **604**; **702** and **704**; **802** and **804**; or **902** and **904**; by layers of the circuit board may be helpful for maintaining the signal from the electrodes. In other embodiments, the printed circuit board **4000** may have more or less than four layers. Additional layers could accommodate additional components, such as a third inductive coil. Alternatively or additionally, the additional layer or layers could provide for having electrodes on different layers.

[0123] In this first layer of the printed circuit board is a top layer. The second layer **4002** is next, the third layer **4003** is lower than the second layer **4002** and the fourth layer is a bottom layer. That configuration may be inverted such that the first later is the bottom layer and the fourth layer is the top layer. Accordingly, the circuit board **4000** layer with the electrodes disposed thereon may be disposed closest or farthest away from a rear of the housing **1500**. In another exemplary embodiment, the inductive coils **4100** and **4101** could be spaced on the farthest apart layers. For example, coil **4100** may be on a first layer and coil **4101** may be on the third layer.

[0124] FIG. **37A** illustrates the printed circuit board **4000** with all four layers and components on all four layers. As is well known the various components and layers can be connected by electronic tracings or other means. There may be vias and holes in the printed circuit board As discussed above, the electrodes **702** and **704** are exemplary, and any of the described electrode arrangements could be used in conjunction with the inductive coils **4100** and **4101**. As shown in FIG. **37A**, the inductive coils **4100** and **4101** are located radially outside of the electrodes **702** and **704** such that they surround the electrodes **702** and **704**. This allows the inductive coils **4100** and **4101** to have a significant size. The size provides for a greater signal for detecting a metal object. Another advantage of the exemplary embodiment with the inductive coils **4100** and **4101** concentric with the electrodes is that the electrodes **702** and **704** both have the same focus of signal. That is, the signal from the electrodes **702** and **704** is at a maximum at the same time that the signal from the inductive coils **4100** and **4101** is at a maximum. In each instance, this is at the horizontal center of the stud finder **101**.

[0125] As additionally shown in FIG. **37A**, there is a gap **4200** between the inductive coils **4100**, **4101** and the electrodes **702**, **704**. The gap **4200** is between the outer circumference formed by the electrodes **702**, **704** and the inner

circumference of the inductive coils, and is formed in a radial direction. The gap **4200** may be 0.025 inches or greater, 0.03 inches or greater, 0.05 inches or greater, 0.075 inches or greater, 0.1 inch or greater, 0.125 inches or greater or 0.15 inches or greater. The gap **4200** helps to reduce any unwanted interference between the electrodes **702**, **704** and the inductive coils **4100**, **4101**. In the exemplary embodiment, the gap **4200** is substantially uniform.

[0126] As shown in FIG. **37A**, there is also a gap **4201** between the inductive coils **4100**, **4101** and the shield electrode **705** (the shield electrode was previously described with respect to other embodiments). In the exemplary embodiment, the shield electrode **705** is circular and larger than the combined area of the electrodes **702** and **704**. Accordingly, in the exemplary embodiment the gap **4201** is smaller than the gap **4200**. The gap **4201** is between the outer circumference of the shield electrode **705** and the inner circumference of the inductive coils **4100**, **4101**, and is formed in a radial direction. The gap **4201** may be 0.025 inches or greater, 0.03 inches or greater, 0.05 inches or greater, 0.075 inches or greater, 0.1 inch or greater, 0.125 inches or greater or 0.15 inches or greater. The gap **4201** may also help to reduce any unwanted interference between the electrodes **702**, **704** and the inductive coils **4100**, **4101**. In the exemplary embodiment, the gap **4201** is substantially uniform.

[0127] In an alternative exemplary embodiment, the inductive coils may be placed inside the electrodes. That is, rather than the inductive coils surrounding the electrodes, the electrodes may surround the inductive coils. In such an exemplary embodiment, the central area between the electrodes may be made larger in order to accommodate the inductive coils and the hole **204**. The gap may be of the sizes previously described. If the inductive coils are placed inside the electrodes, the electrodes surround the inductive coils. As with the previously described embodiment, the electrodes and the inductive coils both provide maximum signal at the same point (the center of the hole). The number of windings of the inductive coils may have to be increased to provide sufficient signal.

[0128] As is additionally shown in FIG. **37A**, the electrodes **702** and **704** are spaced apart from one another along a centerline. This allows for tracings and other electronic connections and components.

[0129] FIG. **37B** illustrates potential cutouts **4500** of the electrodes for traces **4600**.

[0130] FIG. **38** illustrates an electronic hardware block diagram **2500** including a metal detector **2530** with inductive coils **4100** and **4101**. The metal detector **2530** is operatively connected to the microcontroller **2502**, so that the microcontroller **2502** can process a signal from the metal detector **2350** and turn on LED **3000** to indicate when a metal object has been detected. As discussed above, the output may be a single LED **3000** or more or different indicators. The metal detector **2350** may work according to the description of FIG. **33B**, where the inductor **3011** is provided by inductive coils **4100** and **4101**.

[0131] FIG. **39** illustrates the microcontroller's connections with the inductive coils **4100**, **4101**, shield and electrodes **702**, **704**. The connections work similarly to those described with respect to FIGS. **26** and **27**, but have the additional inductive coil components **4100** and **4101**.

[0132] FIG. **40** illustrates a firmware or software flowchart. The flowchart of FIG. **40** is the same as that of FIG.

**28**, and the operations described are the same and are not repeated again here. The flowchart of FIG. **40** adds metal detection **2820** performed by the previously described metal detector **2350** for the stud finder **101** and indicates if metal is detected at step **2822**.

**[0133]** In the claims, any reference signs placed between parentheses shall not be construed as limiting the claim. The word “comprising” or “including” does not exclude the presence of elements or steps other than those listed in a claim. In a device claim enumerating several means, several of these means may be embodied by one and the same item of hardware. The word “a” or “an” preceding an element does not exclude the presence of a plurality of such elements. In any device claim enumerating several means, several of these means may be embodied by one and the same item of hardware. The mere fact that certain elements are recited in mutually different dependent claims does not indicate that these elements cannot be used in combination.

**[0134]** Although the description provided above provides detail for the purpose of illustration based on what is currently considered to be the most practical and preferred embodiments, it is to be understood that such detail is solely for that purpose and that the disclosure is not limited to the expressly disclosed embodiments, but, on the contrary, is intended to cover modifications and equivalent arrangements that are within the spirit and scope of the appended claims. For example, it is to be understood that the present disclosure contemplates that, to the extent possible, one or more features of any embodiment can be combined with one or more features of any other embodiment.

What is claimed is:

1. A stud finder, comprising:
  - a housing;
  - a capacitive sensor disposed in the housing and configured to detect a change in capacitance;
  - a charging capacitor;
  - a sampling capacitor;
  - a charge transfer engine configured to measure a capacitive change in the capacitive sensor; and
  - an indicator configured to indicate the presence of a stud to a user;
 wherein the stud finder is configured to have a charge phase in which the charging capacitor charges the capacitive sensor; and
  - wherein the stud finder is configured to have a transfer phase in which charge from the capacitive sensor is transferred to the sampling capacitor.
2. The stud finder of claim 1, wherein the indicator comprises a graphical display.
3. The stud finder of claim 1, further comprising a shield electrode in the housing.
4. The stud finder of claim 3, wherein the capacitive sensor comprises a first electrode and a second electrode.
5. The stud finder of claim 4, wherein the first electrode is adjacent to the second electrode; and
  - wherein the first electrode and second electrode together form a substantially circular configuration.
6. The stud finder of claim 5, further comprising a hole formed in a center of the circular configuration.
7. The stud finder of claim 4, wherein the first electrode and the second electrode are interdigitating electrodes.
8. The stud finder of claim 1, further comprising an inductive sensor disposed in the housing, the inductive

sensor surrounding the capacitive sensor in a radial direction such that there is a gap between the inductive sensor and the capacitive sensor;

- wherein the inductive sensor comprises at least two inductive coils;
  - wherein the inductive sensor is disposed on a printed circuit board;
  - wherein the printed circuit board comprises a plurality of layers;
  - wherein the inductive sensor is on a different layer of the printed circuit board than the first electrode and the second electrode.
9. A stud finder, comprising:
    - a housing;
    - a capacitive sensor comprising at least a first electrode, the capacitive sensor configured to measure a capacitance as the housing is moved across a surface;
    - a processor configured to receive data from the capacitive sensor and analyze a data trend direction to determine a location of the stud; and
    - an indicator configured to indicate the presence of a stud to a user.

**10.** The stud finder of claim 9, wherein the processor is configured modify a conversion gain parameter.

**11.** The stud finder of claim 9, wherein the processor is configured to modify a conversion count.

**12.** The stud finder of claim 9, wherein the processor is configured to smooth the received data.

**13.** The stud finder of claim 9, wherein the stud finder comprises a charge phase in which a charging capacitor charges the capacitive sensor.

**14.** The stud finder of claim 13, wherein the stud finder comprises a transfer phase in which charge from the capacitive sensor is transferred to a sampling capacitor.

**15.** The stud finder of claim 9, wherein the capacitive sensor comprises at least the first electrode and a second electrode.

**16.** The stud finder of claim 9, wherein the indicator comprises a graphical display.

**17.** The stud finder of claim 9, further comprising an inductive sensor disposed in the housing, the inductive sensor surrounding the capacitive sensor in a radial direction such that there is a gap between the inductive sensor and the capacitive sensor;

- wherein the inductive sensor comprises at least two inductive coils;
- wherein the inductive sensor is disposed on a printed circuit board;
- wherein the printed circuit board comprises a plurality of layers;
- wherein the inductive sensor is on a different layer of the printed circuit board than the first electrode and the second electrode.

**18.** A stud finder, comprising:

- a housing;
- a capacitive sensor comprising a first electrode and a second electrode, the capacitive sensor configured to measure a capacitance as the stud finder is moved across a surface;
- a first shield electrode;
- a processor configured smooth data measured from the capacitive sensor and analyze a data trend direction of the data to determine a location of the stud; and

an indicator configured to indicate the presence of a stud to a user.

**19.** The stud finder of claim **18**, wherein the processor is configured modify a conversion gain parameter.

**20.** The stud finder of claim **18**, wherein the processor is configured to modify a conversion count.

\* \* \* \* \*