



(19) **United States**

(12) **Patent Application Publication**
CHEN et al.

(10) **Pub. No.: US 2020/0161200 A1**

(43) **Pub. Date: May 21, 2020**

(54) **SEMICONDUCTOR PACKAGE DEVICE AND METHOD OF MANUFACTURING THE SAME**

(71) Applicant: **Advanced Semiconductor Engineering, Inc.**, Kaohsiung (TW)

(72) Inventors: **Yi CHEN**, Kaohsiung (TW);
Chang-Lin YEH, Kaohsiung (TW);
Jen-Chieh KAO, Kaohsiung (TW)

(73) Assignee: **Advanced Semiconductor Engineering, Inc.**, Kaohsiung (TW)

(21) Appl. No.: **16/751,139**

(22) Filed: **Jan. 23, 2020**

Related U.S. Application Data

(63) Continuation of application No. 15/884,313, filed on Jan. 30, 2018, now Pat. No. 10,580,713.

(60) Provisional application No. 62/456,553, filed on Feb. 8, 2017.

Publication Classification

(51) **Int. Cl.**
H01L 23/31 (2006.01)
H01L 23/498 (2006.01)
H01Q 21/06 (2006.01)
H01L 23/10 (2006.01)

H01Q 1/22 (2006.01)
H01Q 13/10 (2006.01)
H01L 23/00 (2006.01)
H01Q 19/10 (2006.01)
H01L 23/66 (2006.01)
(52) **U.S. Cl.**
CPC **H01L 23/3114** (2013.01); **H01L 24/16** (2013.01); **H01Q 21/061** (2013.01); **H01L 23/10** (2013.01); **H01Q 1/2283** (2013.01); **H01Q 13/10** (2013.01); **H01L 24/85** (2013.01); **H01L 24/73** (2013.01); **H01Q 19/10** (2013.01); **H01L 24/13** (2013.01); **H01Q 1/2291** (2013.01); **H01L 23/66** (2013.01); **H01L 23/49827** (2013.01); **H01L 24/48** (2013.01); **H01L 23/49822** (2013.01); **H01L 23/49816** (2013.01); **H01L 2924/14** (2013.01); **H01L 2224/48227** (2013.01); **H01L 2924/15321** (2013.01); **H01L 2224/16225** (2013.01); **H01L 2924/00014** (2013.01); **H01L 23/49833** (2013.01)

(57) **ABSTRACT**

A semiconductor package device includes a first substrate, a second substrate and a first spacer. The first substrate includes a first divided pad. The second substrate includes a second divided pad disposed above the first divided pad. The first spacer is disposed between the first divided pad and the second divided pad. The first spacer is in contact with the first divided pad and the second divided pad.

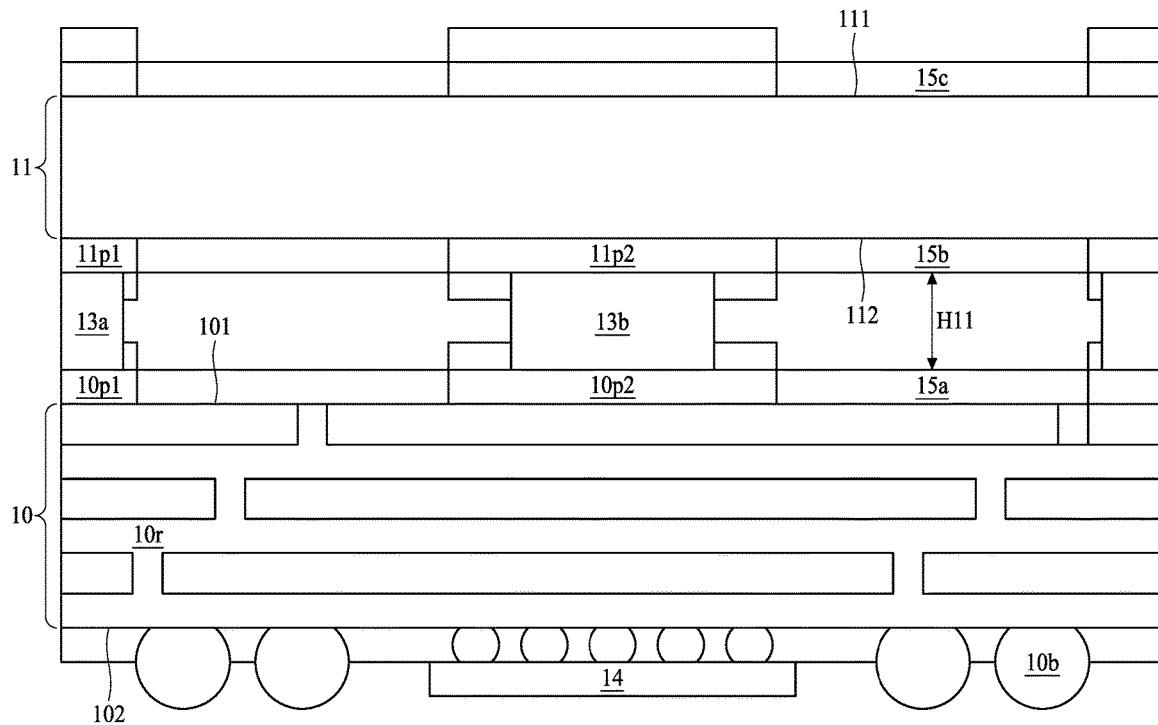

1

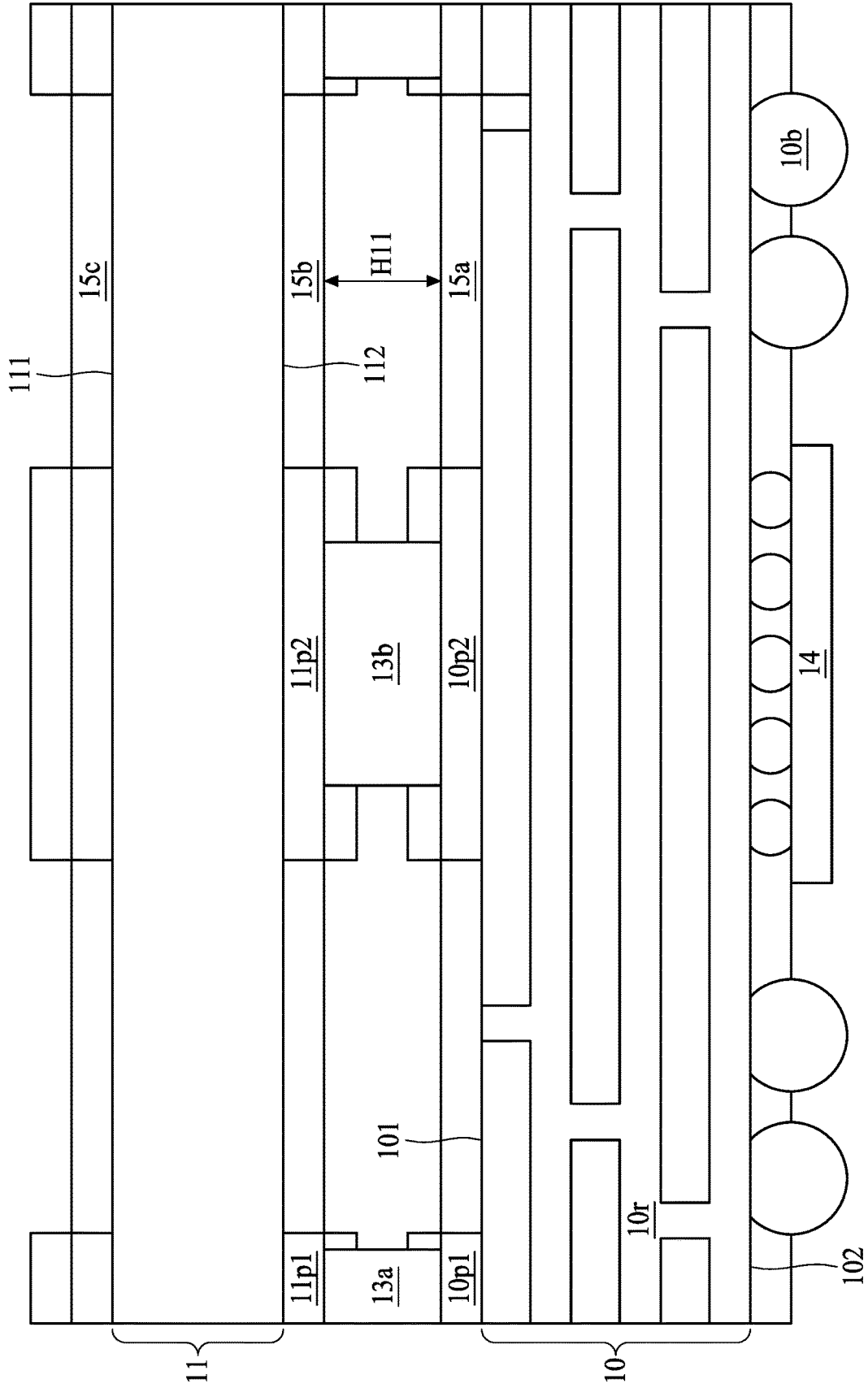

FIG. 1

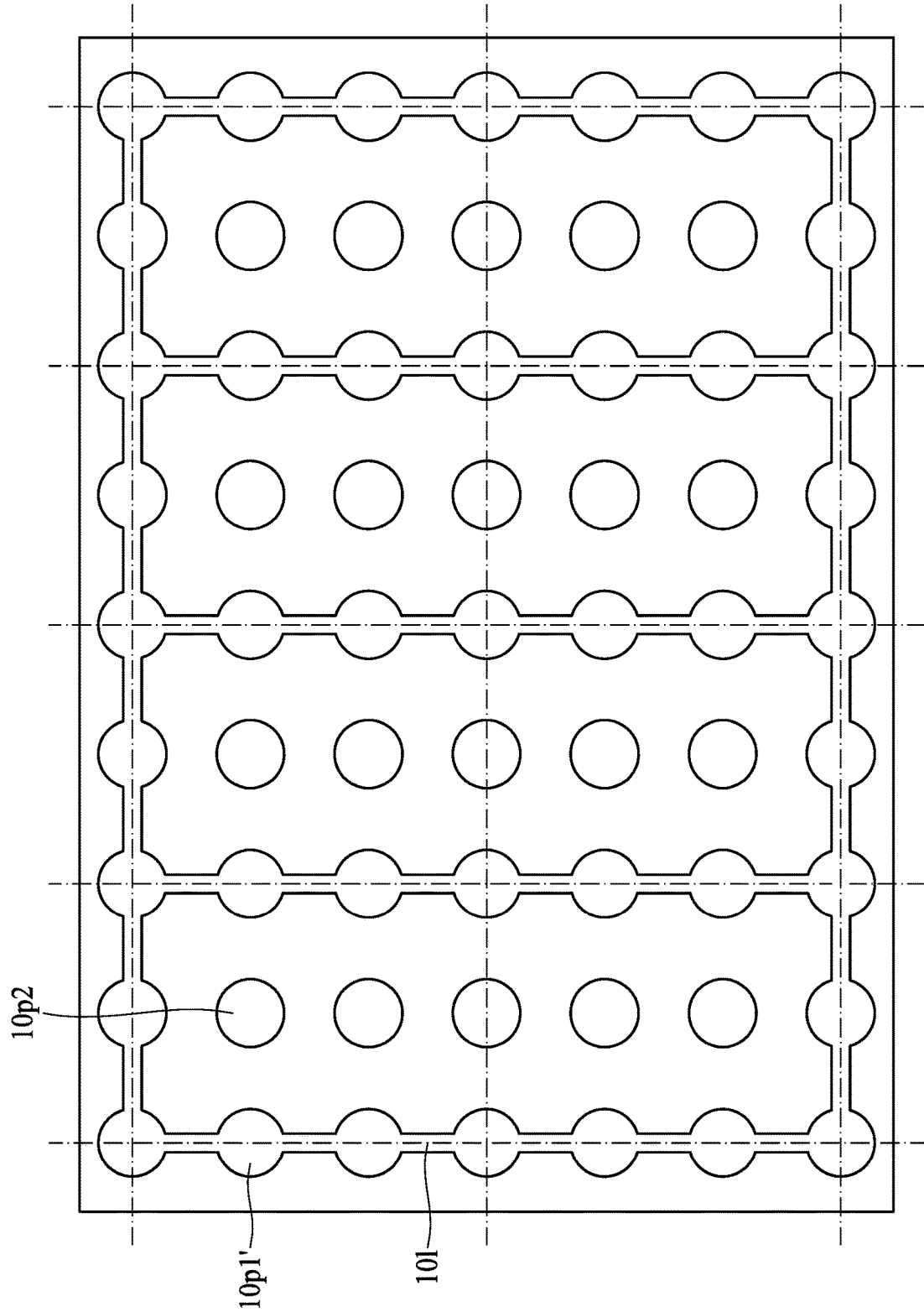

FIG. 2

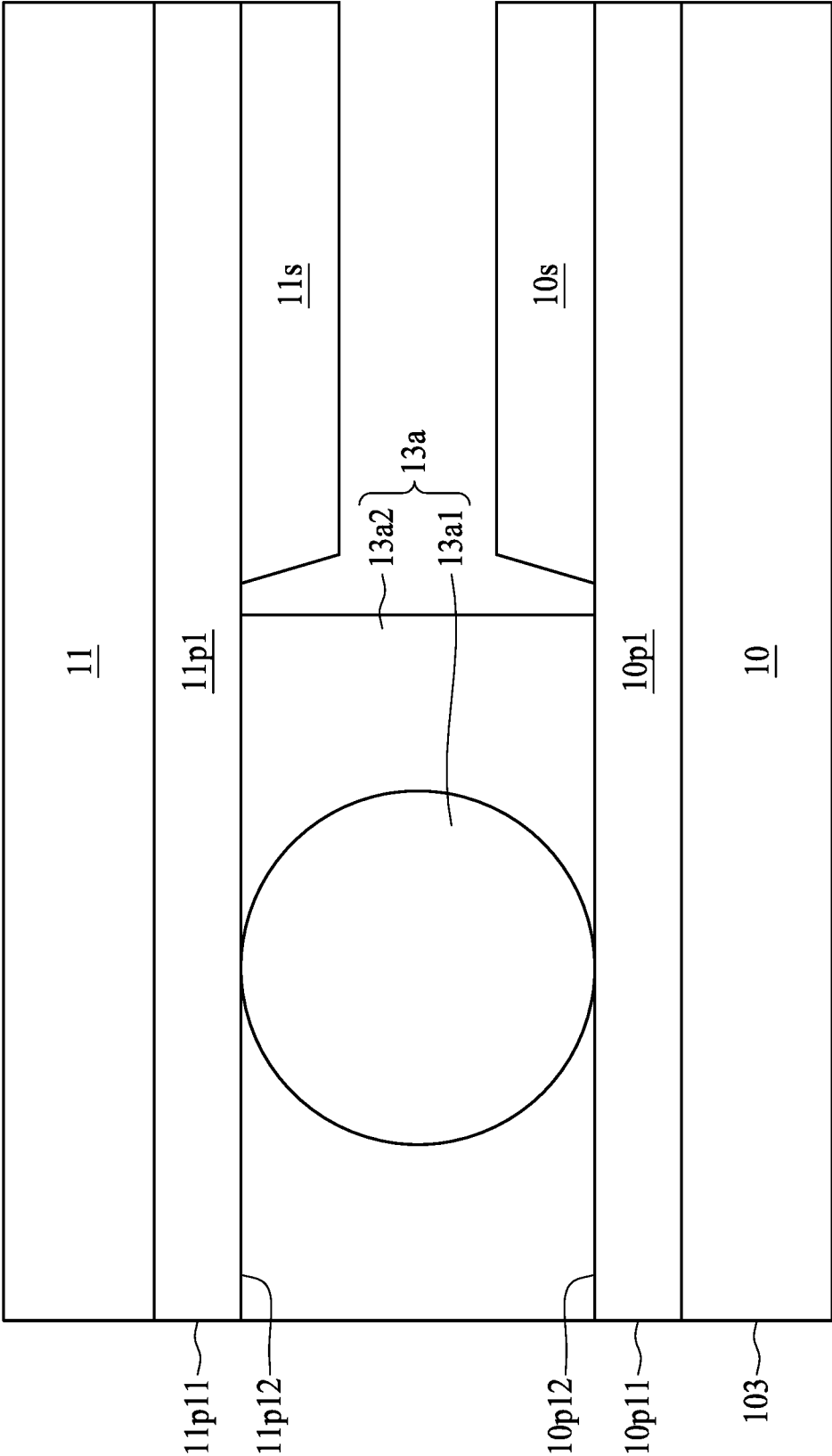

FIG. 3A

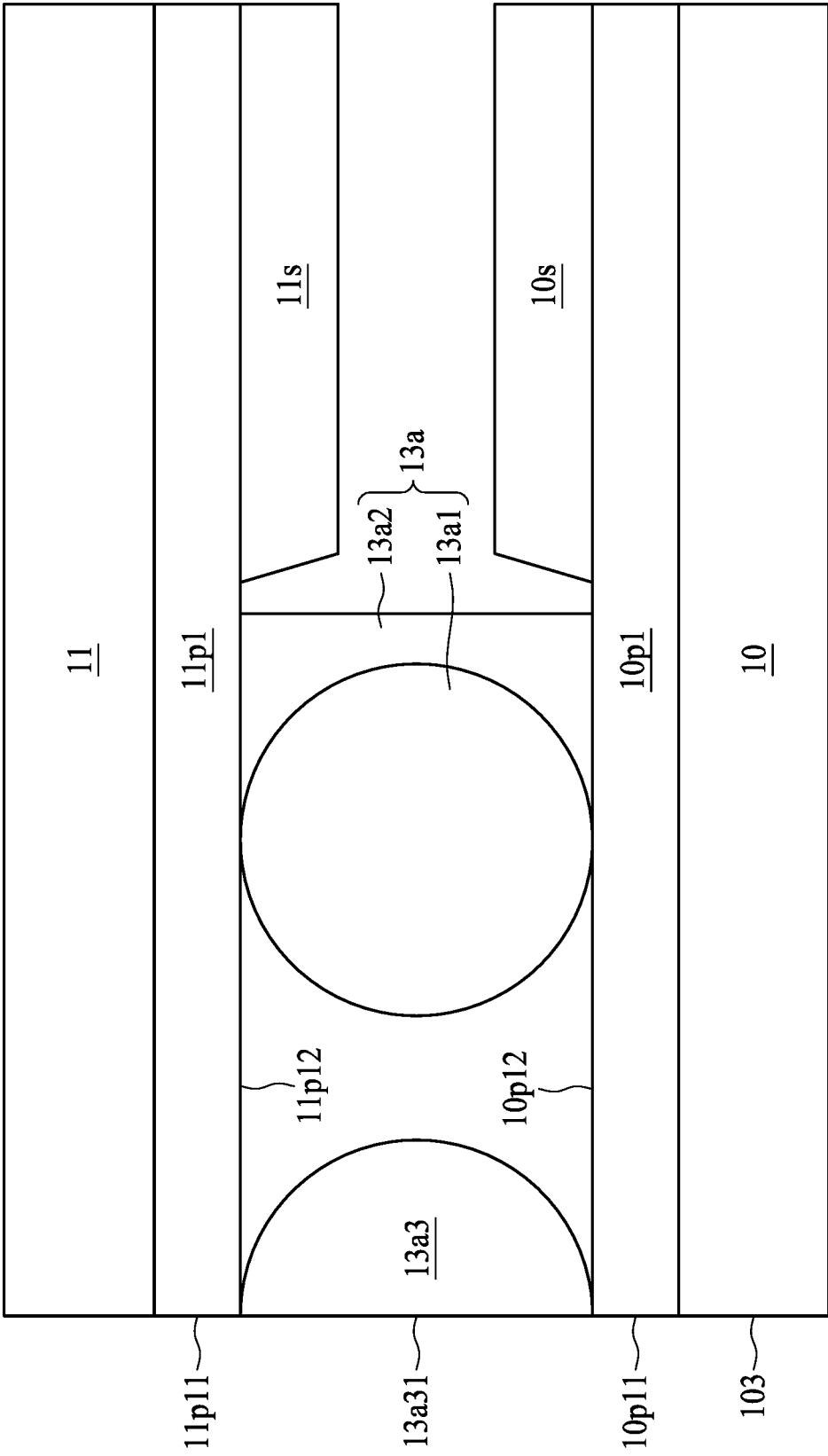

FIG. 3B

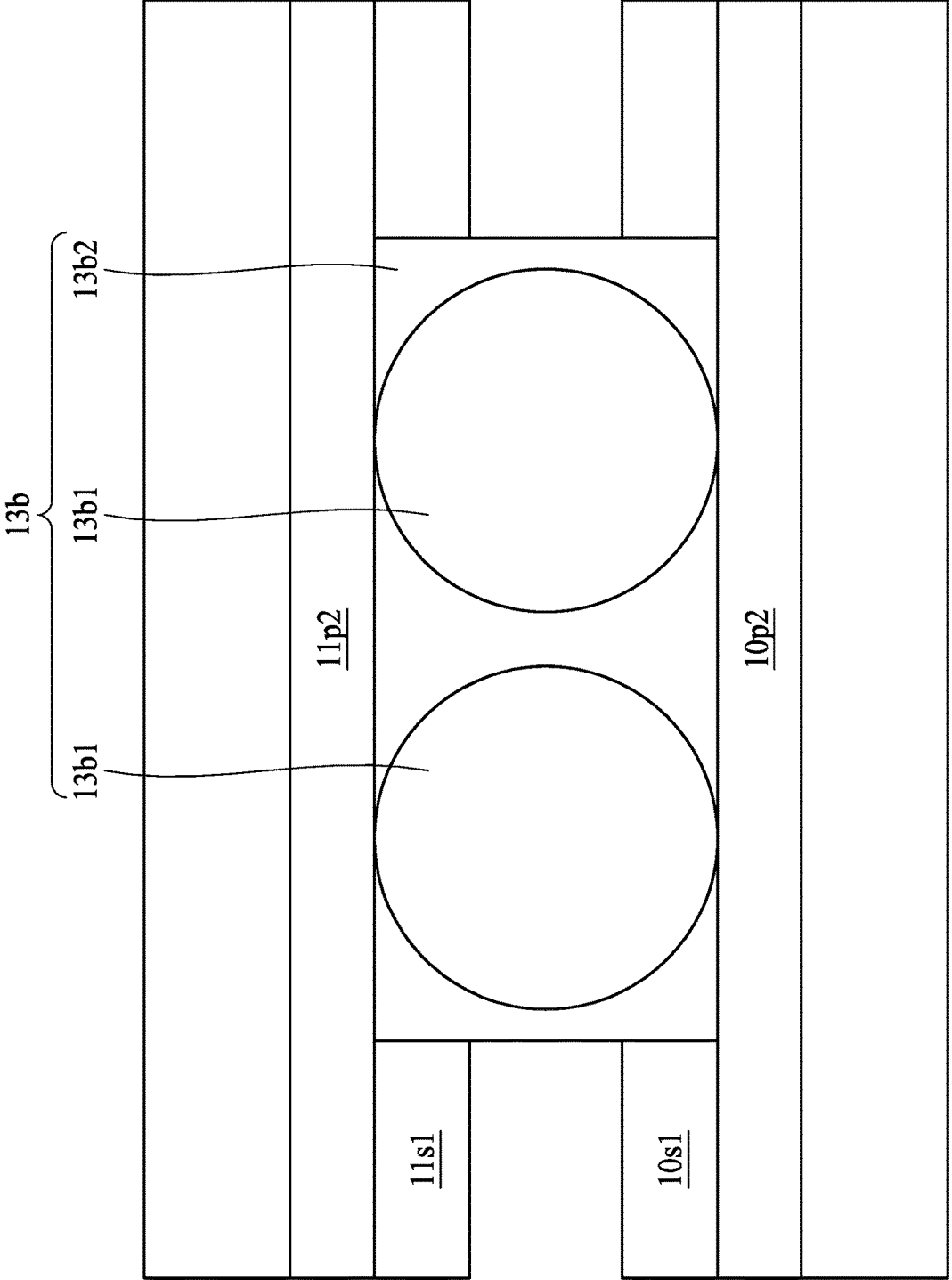

FIG. 4

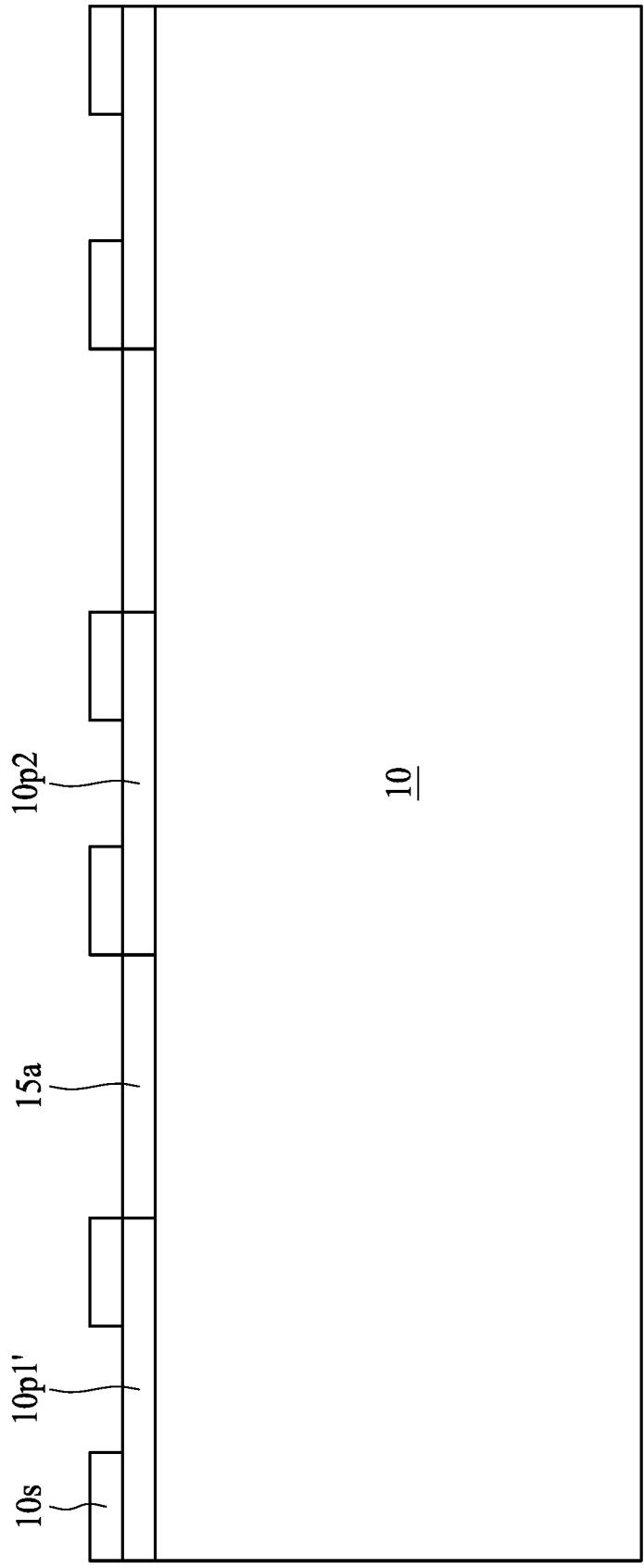

FIG. 5A

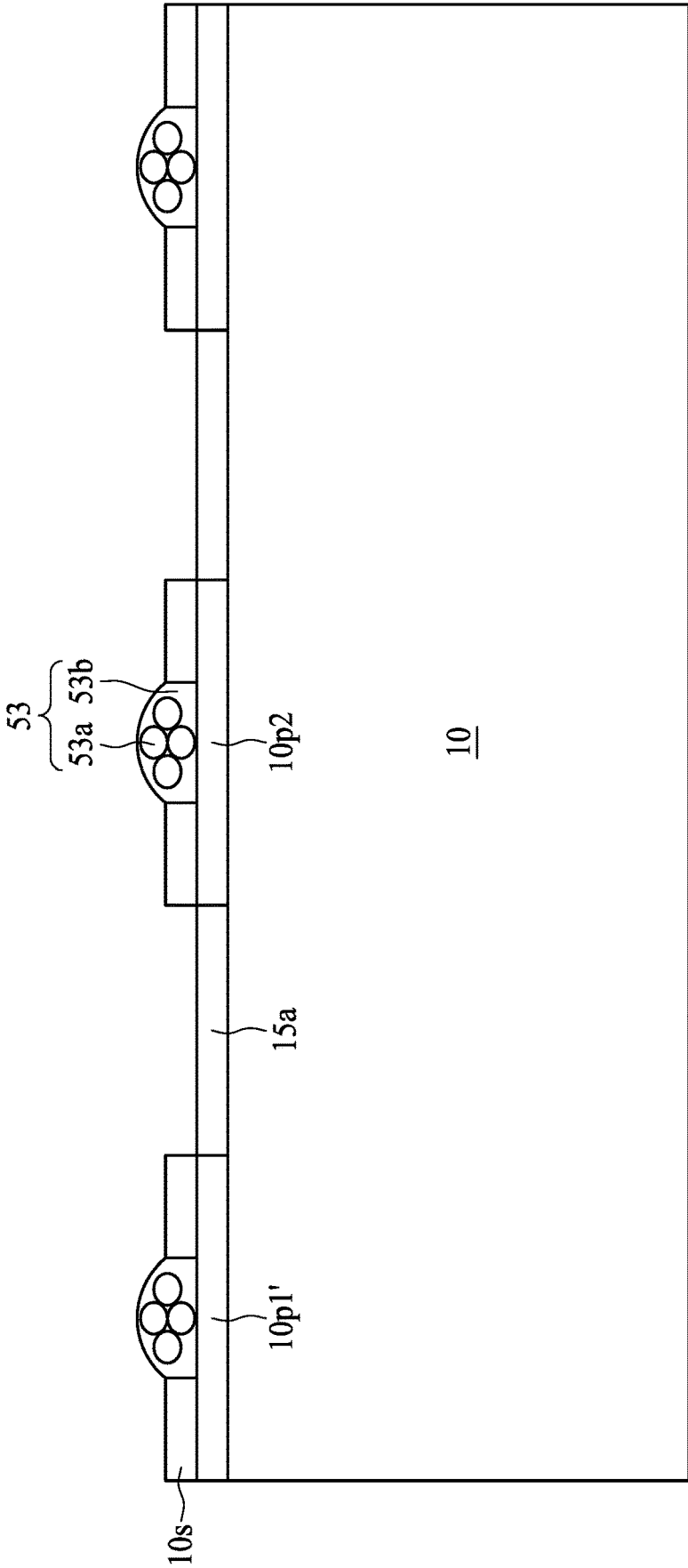

FIG. 5B

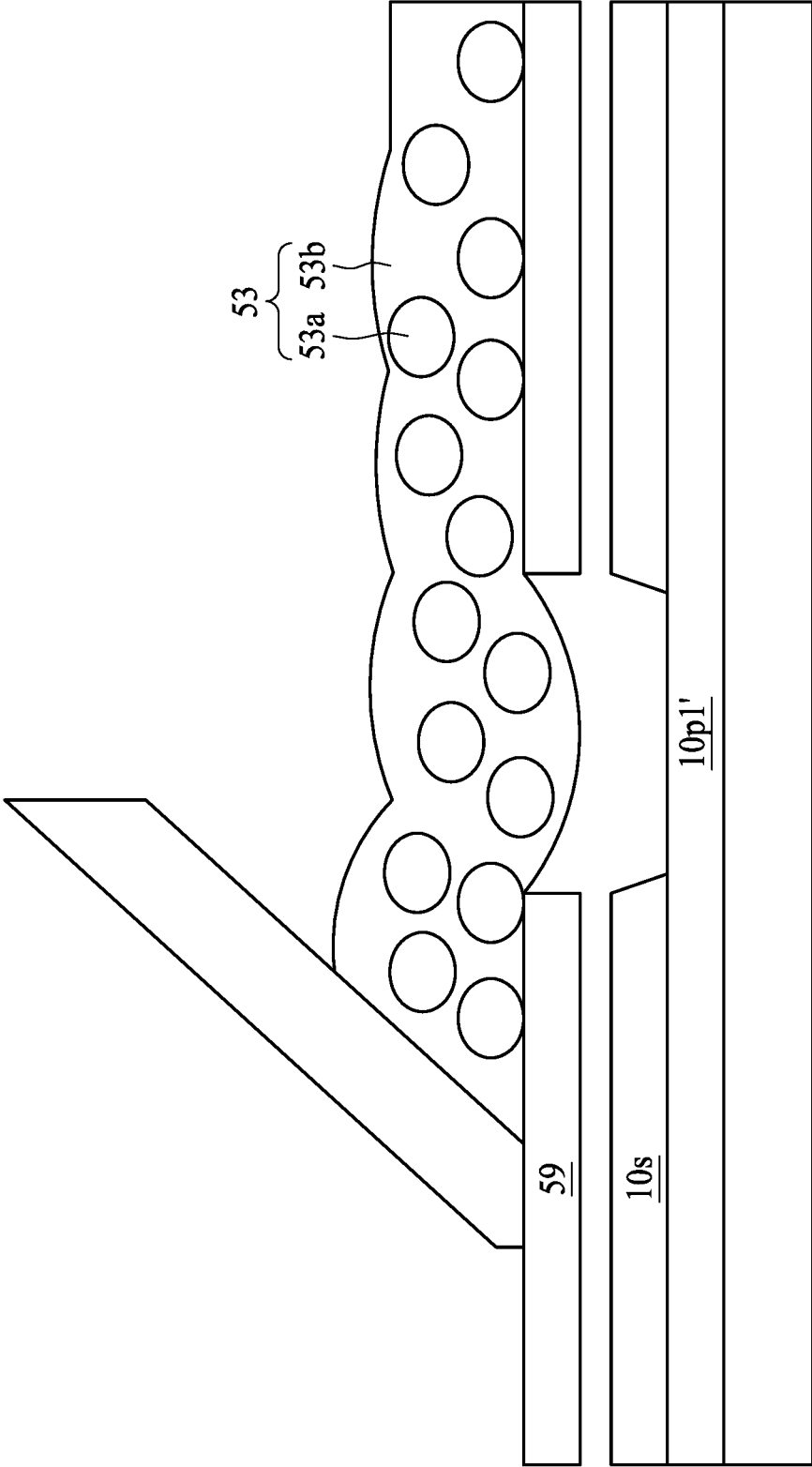

FIG. 5C

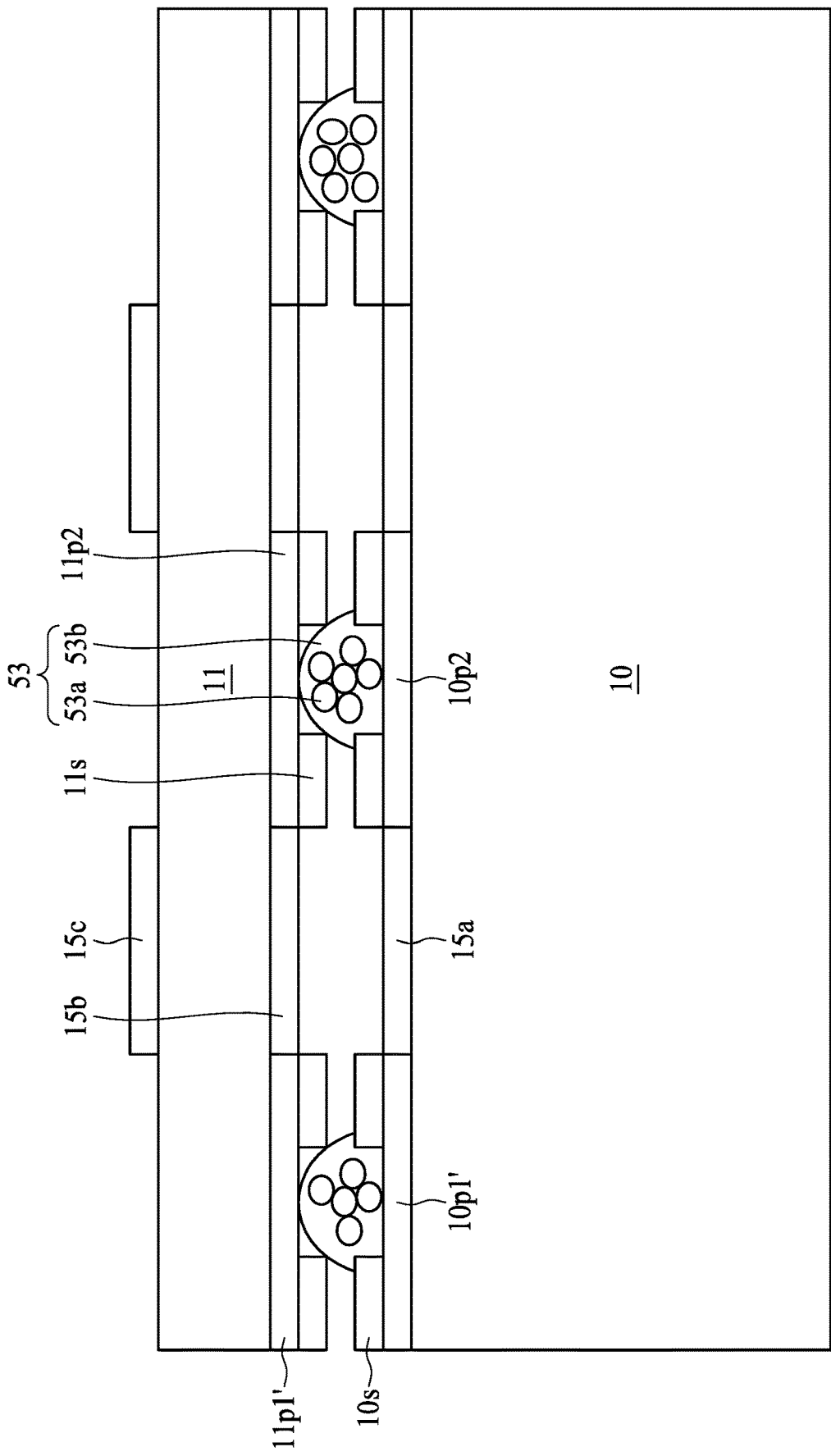

FIG. 5D

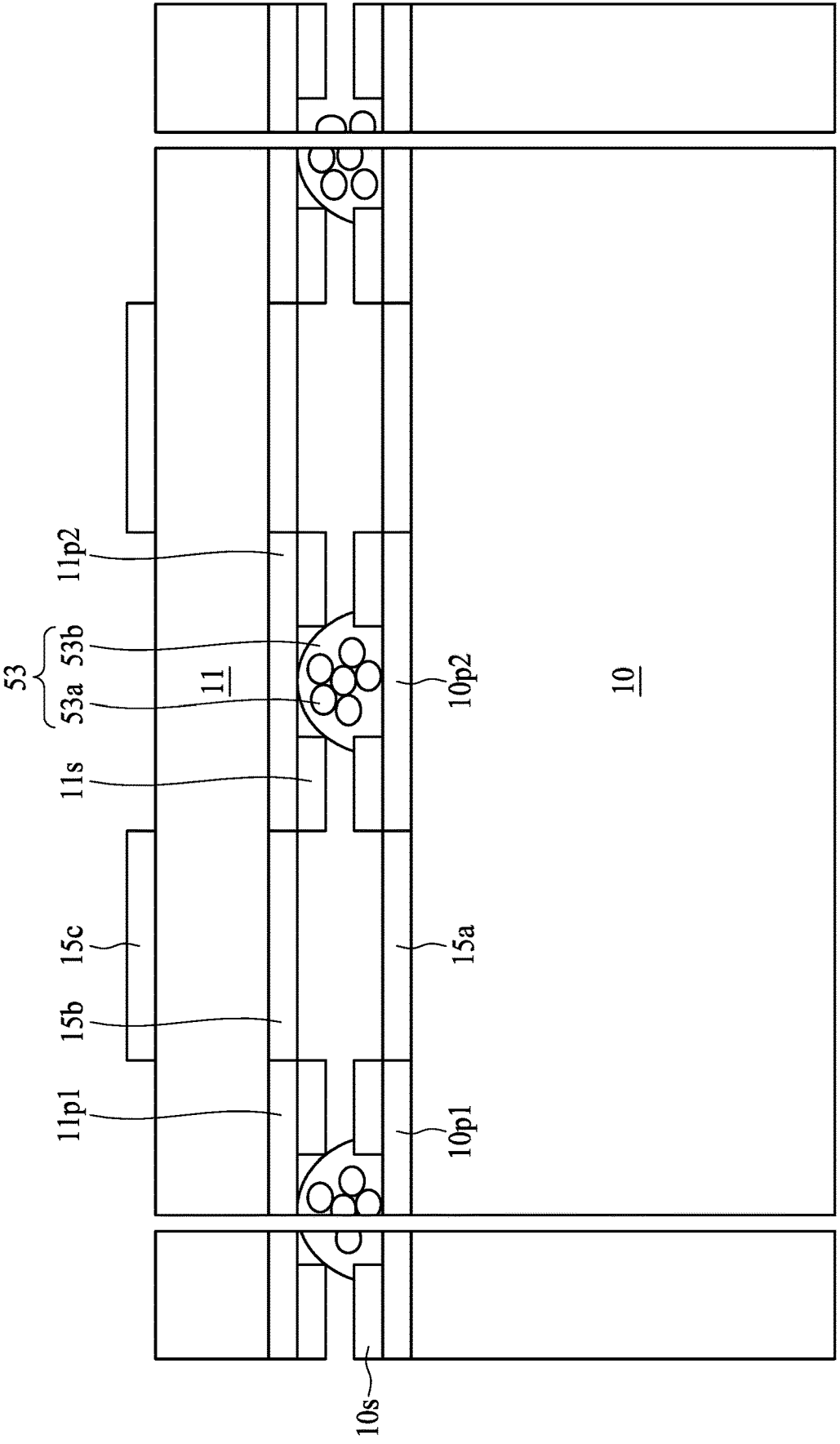

FIG. 5E

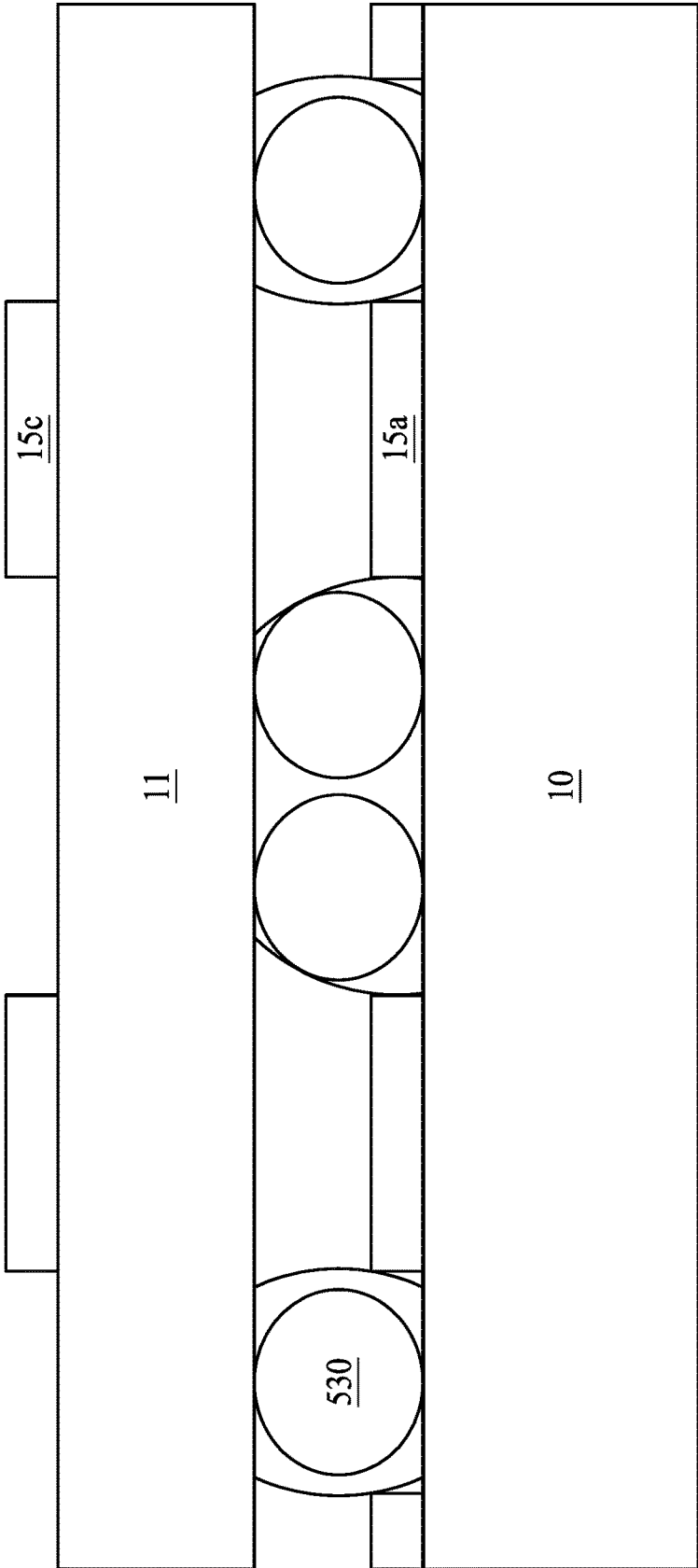

FIG. 6

7

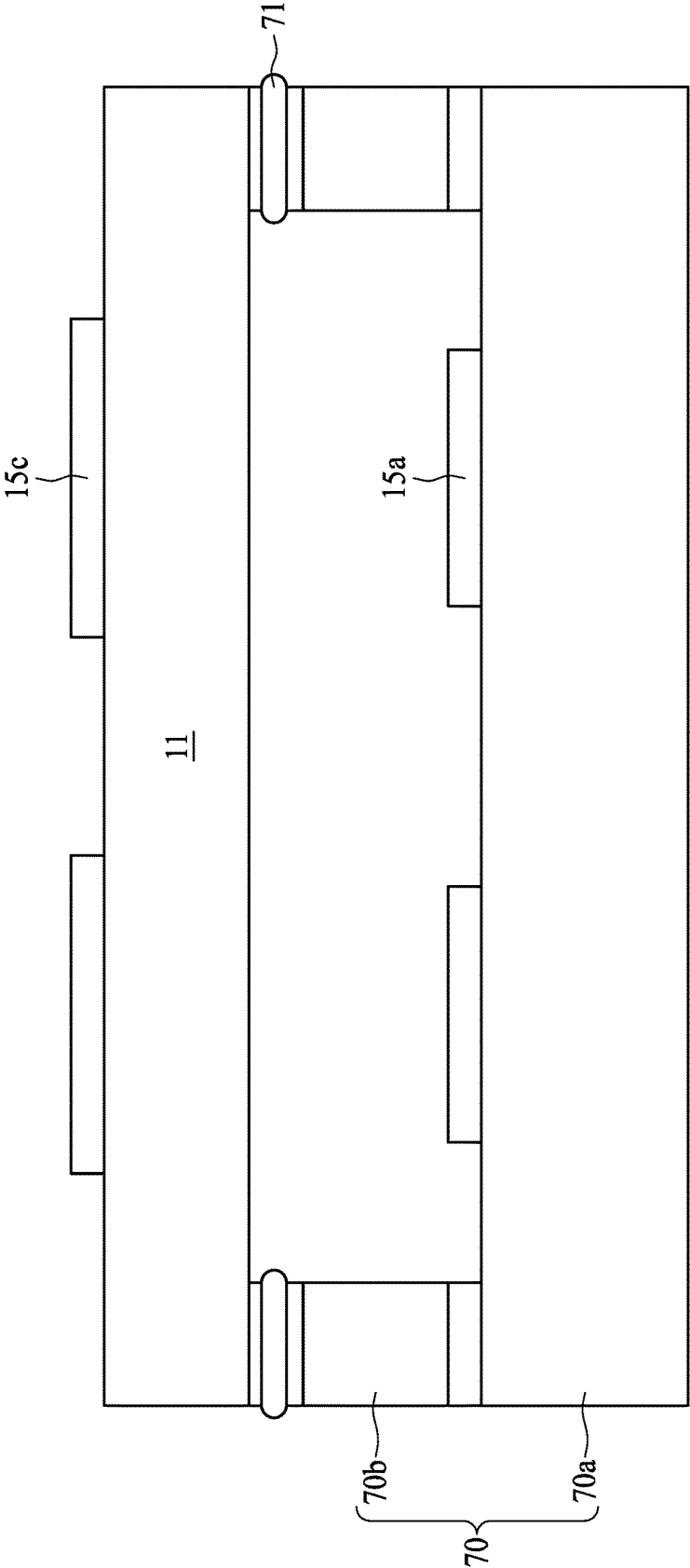

FIG. 7

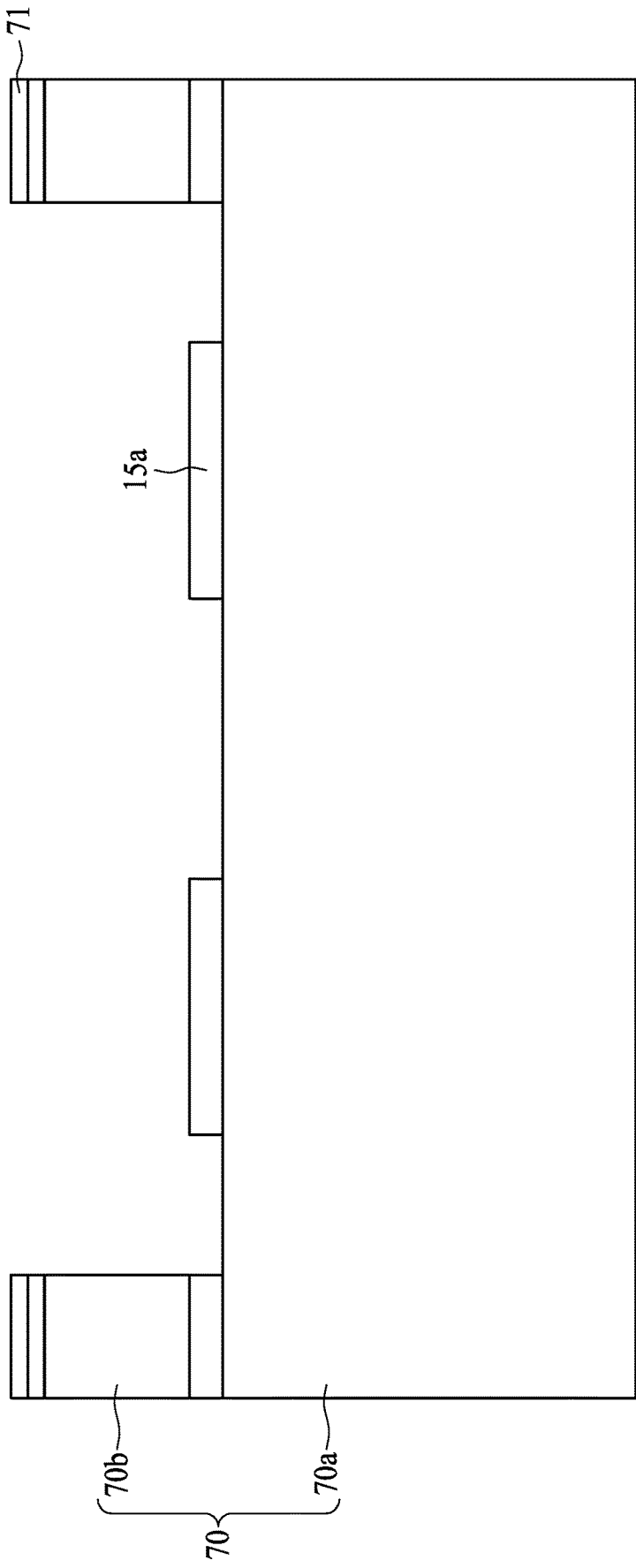

FIG. 8A

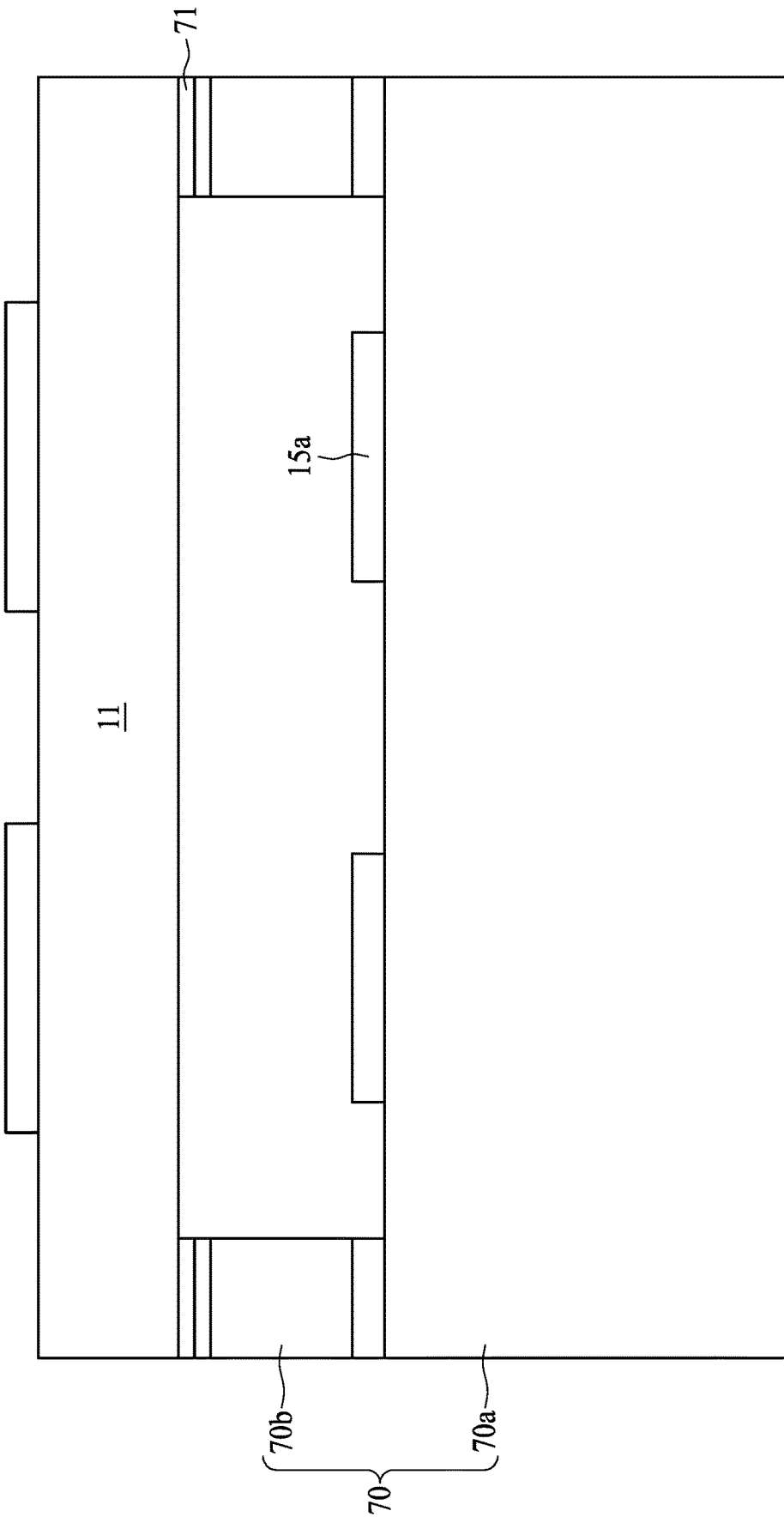

FIG. 8B

91

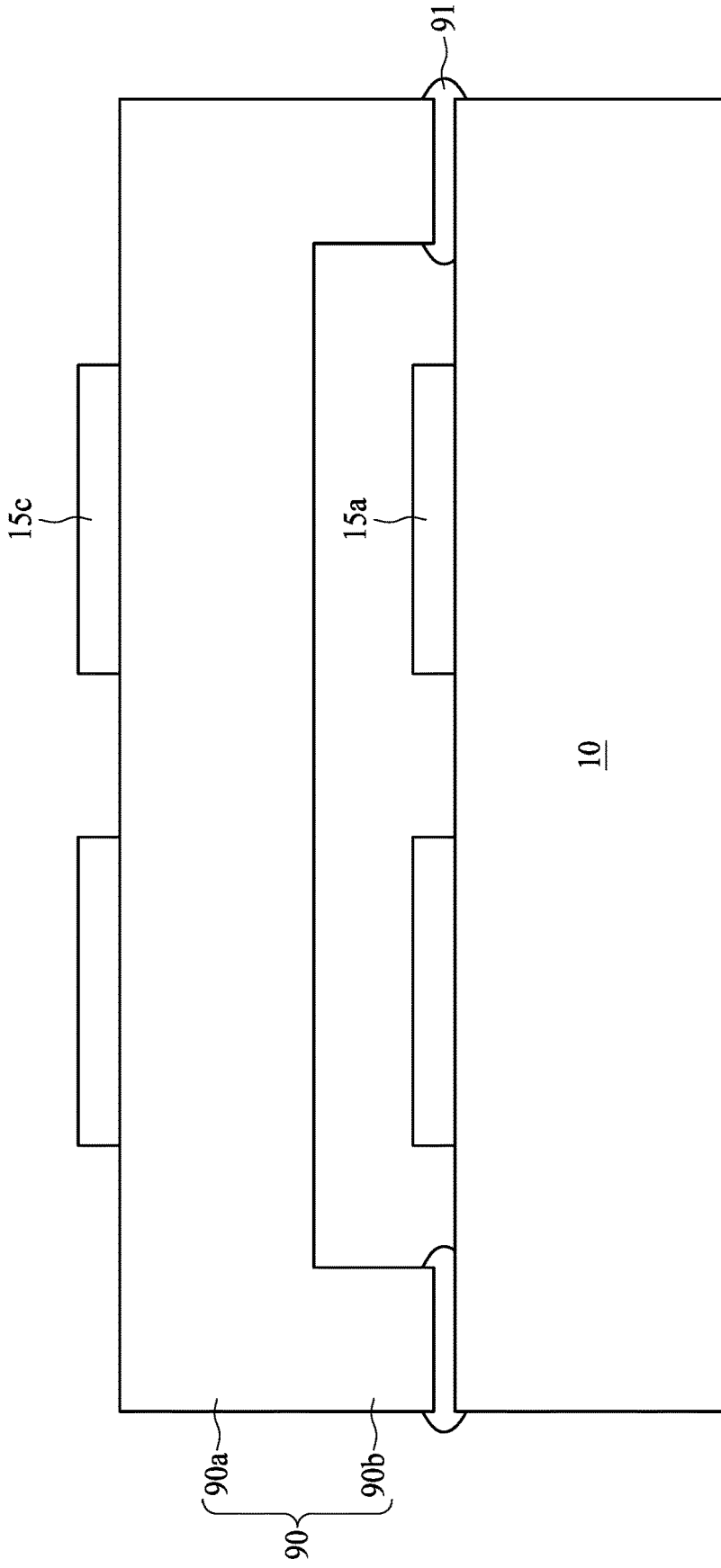

FIG. 9

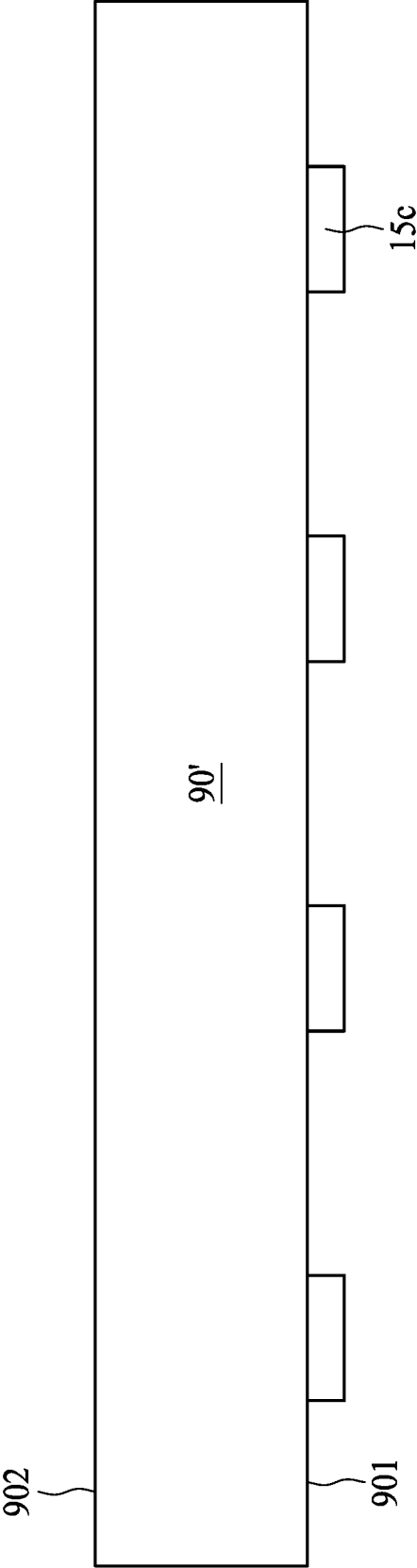

FIG. 10A

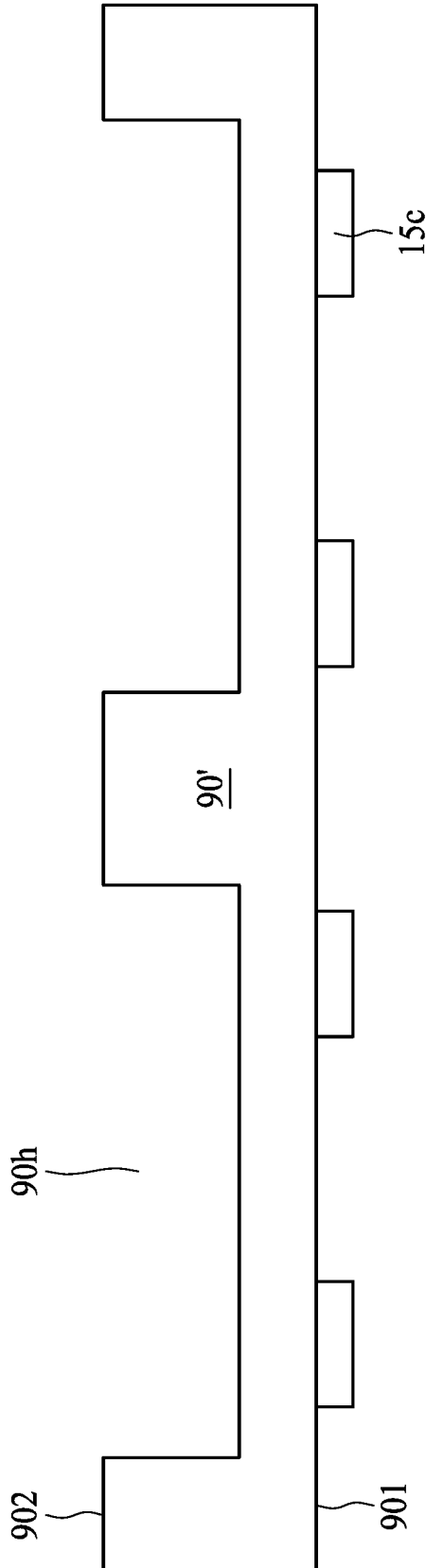

FIG. 10B

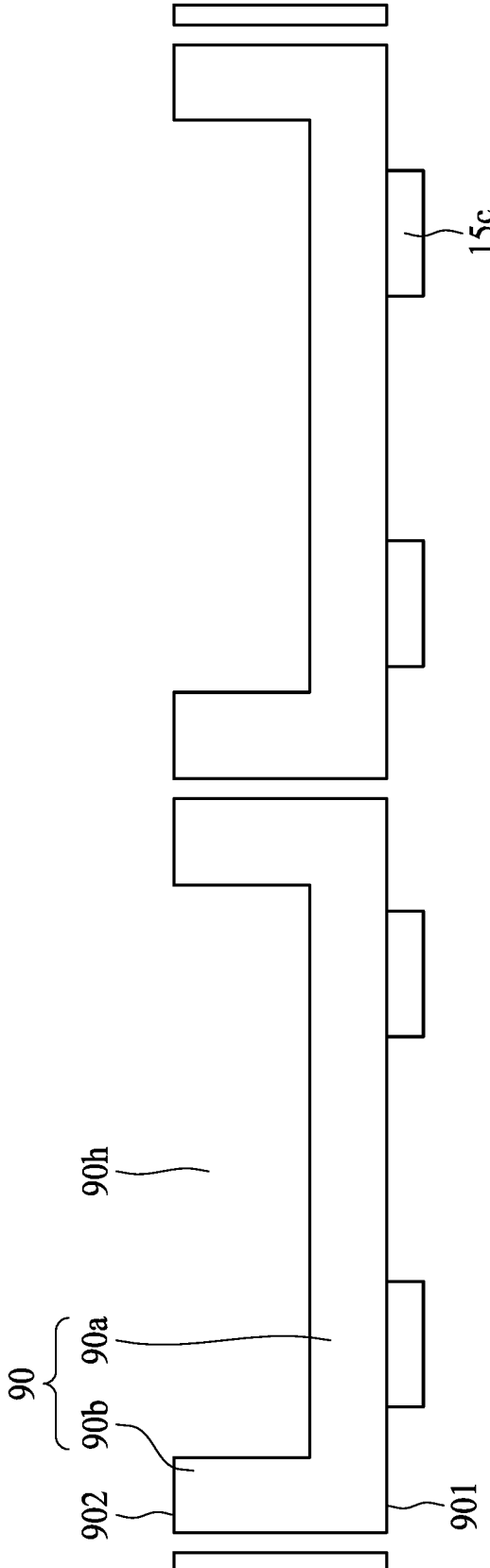

FIG. 10C

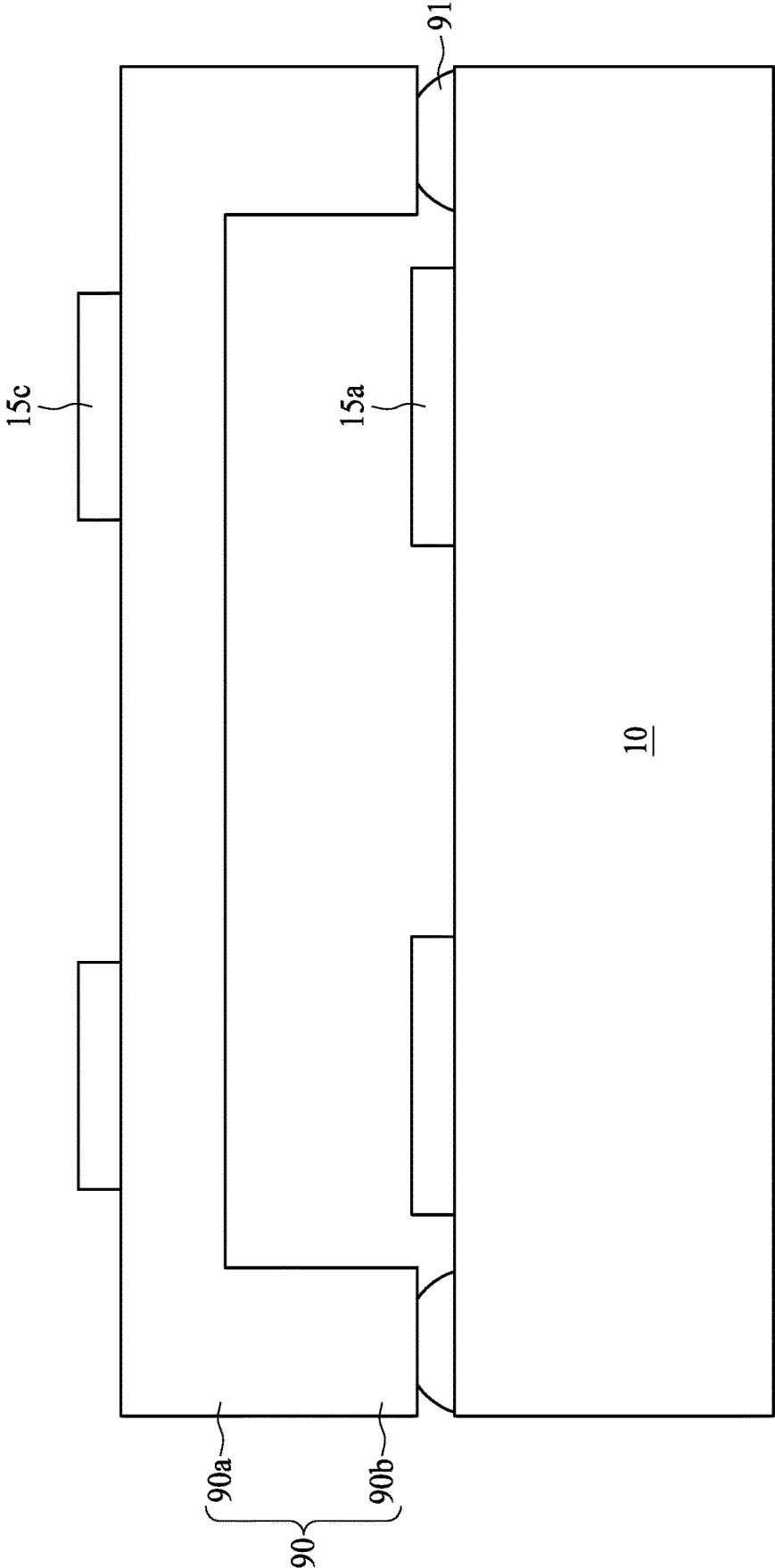

FIG. 10D

SEMICONDUCTOR PACKAGE DEVICE AND METHOD OF MANUFACTURING THE SAME

CROSS-REFERENCE TO RELATED APPLICATION

[0001] This application is a continuation of U.S. patent application Ser. No. 15/884,313 filed Jan. 30, 2018, which application claims the benefit of and priority to U.S. Provisional Application No. 62/456,553, filed Feb. 8, 2017, the contents of which are incorporated herein by reference in its entirety.

BACKGROUND

1. Technical Field

[0002] The present disclosure relates generally to a semiconductor package device and a method of manufacturing the same, and to a semiconductor package device including an antenna structure and a method of manufacturing the same.

2. Description of the Related Art

[0003] The development of mobile communication has caused demand for high data rates and stable communication quality, and high frequency wireless transmission (e.g., 28 GHz or 60 GHz) has become one of the most important topics in the mobile communication industry. In order to achieve such high frequency wireless transmission, the signal can be transmitted in a band having wavelengths from about ten to about one millimeter (“millimeter wave,” or “mmWave”). However, the signal attenuation is one of the problems in millimeter wave transmission.

SUMMARY

[0004] In one or more embodiments, according to one aspect, a semiconductor package device includes a first substrate, a second substrate and a first spacer. The first substrate includes a first divided pad. The second substrate includes a second divided pad disposed above and facing toward the first divided pad. The first spacer is disposed between the first divided pad and the second divided pad. The first spacer is in contact with the first divided pad and the second divided pad.

[0005] In one or more embodiments, according to another aspect, a semiconductor package device includes a first substrate, a second substrate and at least two spacers. The first substrate includes a first pad. The second substrate includes a second pad disposed above and facing toward the first pad. At least two spacers are disposed between the first pad and the second pad.

[0006] In one or more embodiments, according to another aspect, a method of manufacturing a semiconductor package device includes (a) providing a first substrate, the first substrate including a first set of pads; (b) disposing a plurality of spacers on the first set of pads, wherein at least two of the spacers are disposed on a first pad of the first set of pads; and (c) disposing a second substrate on the first substrate, the second substrate including a second set of pads respectively disposed above the first set of pads, wherein a second pad of the second set of pads is disposed on the at least two of the spacers.

BRIEF DESCRIPTION OF THE DRAWINGS

[0007] Aspects of the present disclosure are best understood from the following detailed description when read with the accompanying drawings. It is noted that various features may not be drawn to scale, and the dimensions of the various features may be arbitrarily increased or reduced for clarity of discussion.

[0008] FIG. 1 illustrates a cross-sectional view of a semiconductor package device in accordance with some embodiments of the present disclosure.

[0009] FIG. 2 illustrates a top view of a substrate strip including a substrate shown in FIG. 1 in accordance with some embodiments of the present disclosure.

[0010] FIG. 3A illustrates a cross-sectional view of a support structure in FIG. 1 in accordance with some embodiments of the present disclosure.

[0011] FIG. 3B illustrates a cross-sectional view of the support structure in FIG. 1 in accordance with some embodiments of the present disclosure.

[0012] FIG. 4 illustrates a cross-sectional view of the support structure in FIG. 1 in accordance with some embodiments of the present disclosure.

[0013] FIG. 5A, FIG. 5B, FIG. 5C, FIG. 5D and FIG. 5E illustrate a method of manufacturing a semiconductor package device in accordance with some embodiments of the present disclosure.

[0014] FIG. 6 illustrates a cross-sectional view of a semiconductor package device in accordance with some embodiments of the present disclosure.

[0015] FIG. 7 illustrates a cross-sectional view of a semiconductor package device in accordance with some embodiments of the present disclosure.

[0016] FIG. 8A and FIG. 8B illustrate a method of manufacturing a semiconductor package device in accordance with some embodiments of the present disclosure.

[0017] FIG. 9 illustrates a cross-sectional view of a semiconductor package device in accordance with some embodiments of the present disclosure.

[0018] FIG. 10A, FIG. 10B, FIG. 10C and FIG. 10D illustrate a method of manufacturing a semiconductor package device in accordance with some embodiments of the present disclosure.

[0019] Common reference numerals are used throughout the drawings and the detailed description to indicate the same or similar elements. The present disclosure will be readily understood from the following detailed description taken in conjunction with the accompanying drawings.

DETAILED DESCRIPTION

[0020] FIG. 1 illustrates a cross-sectional view of a semiconductor package device 1 in accordance with some embodiments of the present disclosure. The semiconductor package device 1 includes substrates 10, 11, support structures 13a, 13b, an electronic component 14, and antenna patterns 15a, 15b, 15c.

[0021] The substrate 10 may be, for example, a printed circuit board, such as a paper-based copper foil laminate, a composite copper foil laminate, or a polymer-impregnated glass-fiber-based copper foil laminate. The substrate 10 may include an interconnection structure 10r, such as a redistribution layer (RDL) or a grounding element. In some embodiments, the substrate 10 may be a single-layer substrate or multi-layer substrate which includes a core layer

and a conductive material and/or structure disposed on an upper surface and a bottom surface of the substrate **10**. The conductive material and/or structure may include a plurality of traces.

[0022] In some embodiments, a surface **101** of the substrate **10** is referred to as a top surface or a first surface and a surface **102** of the substrate **10** is referred to as a bottom surface or a second surface. In some embodiments, the substrate **10** may include a plurality of conductive pads (e.g., **10p1**, **10p2**) or solder bumps **10b** on its first surface **101** and/or second surface **102**. In some embodiments, the conductive pads include a divided conductive pad **10p1** and a non-divided conductive pad **10p2**. For example, as shown in FIG. 2, which illustrates a top view of a substrate strip including the substrate **10** before a singulation process, the divided conductive pad **10p1** is formed after the singulation process to cut through a conductive pad **10p1'** that is located at a scribe line (or cut line) **101**. In addition, as shown in FIG. 2, the non-divided conductive pad **10p2** is not located at the scribe line during the singulation process, and thus the non-divided conductive pad **10p2** has not been divided. In one or more embodiments, the divided conductive pad **10p1** may be about 0.9 or less, about 0.8 or less, about 0.7 or less, about 0.6 or less, or about 0.5 or less times as wide as is the non-divided conductive pad **10p2**.

[0023] The antenna pattern **15a** is disposed on the first surface **101** of the substrate **10**. In some embodiments, the antenna pattern **15a** includes a plurality of antenna elements. For example, the antenna pattern **15a** may include an array of antenna elements. In some embodiments, the antenna **15a** may include an N×N array of antenna elements, where N is an integer greater than 1.

[0024] The electronic component **14** is disposed on the second surface **102** of the substrate. In some embodiments, the electronic component **14** is electrically connected to the antenna pattern **15a** through the interconnection structure **10r** within the substrate **10**. The electronic component **14** may be a chip or a die including a semiconductor substrate, one or more integrated circuit devices and one or more overlying interconnection structures therein. The integrated circuit devices may include active devices such as transistors and/or passive devices such resistors, capacitors, inductors, or a combination thereof. The electronic component **14** may be electrically connected to the substrate **10** (e.g., to the conductive pads), and electrical connection may be attained by way of flip-chip or wire-bond techniques.

[0025] The substrate **11** is disposed over the substrate **10** and spaced apart from the substrate **10**. In some embodiments, the substrate **11** can be the same as or different from the substrate **10** depending on design specifications. In some embodiments, a surface **111** of the substrate **11** is referred to as a top surface or a first surface and a surface **112** of the substrate **11** is referred to as a bottom surface or a second surface. In some embodiments, the substrate **11** may include a plurality of conductive pads (e.g., **11p1**, **11p2**) on its first surface **111** and/or second surface **112**. In some embodiments, similar to the conductive pads **10p1**, **10p2** of the substrate **10**, the substrate **11** includes a divided conductive pad **11p1** and a non-divided conductive pad **11p2**. The divided conductive pad **11p1** is disposed corresponding to (e.g. above) the divided conductive pad **10p1**, and the non-divided conductive pad **11p2** is disposed corresponding to (e.g. above) the non-divided conductive pad **10p2**. For example, the divided conductive pad **10p1** may be aligned

with the divided conductive pad **11p1** and the non-divided conductive pad **10p2** may be aligned with the non-divided conductive pad **11p2**. In one or more embodiments, the divided conductive pad **11p1** may be about 0.9 or less, about 0.8 or less, about 0.7 or less, about 0.6 or less, or about 0.5 or less times as wide as is the non-divided conductive pad **11p2**.

[0026] The support structures **13a**, **13b** are disposed between the substrate **10** and the substrate **11** to separate the substrate **10** and the substrate **11** and define a cavity (e.g. an air cavity) or cavities there between. In some embodiments, the support structure **13a** is disposed between the divided conductive pads **10p1** and **11p1** and in contact with the divided conductive pads **10p1** and **11p1**. The support structure **13b** is disposed between the non-divided conductive pads **10p2** and **11p2** and in contact with the non-divided conductive pads **10p2** and **11p2**.

[0027] The antenna pattern **15c** is disposed on the first surface **111** of the substrate **11**. The antenna pattern **15b** is disposed on the second surface **112** of the substrate **11** corresponding to (e.g. disposed above) the antenna pattern **15a** disposed on the first surface **101** of the substrate **10**. For example, the antenna pattern **15b** faces toward the antenna pattern **15a**. For example, the antenna pattern **15b** may be aligned with the antenna pattern **15a**. In some embodiments, the antenna pattern **15b** or **15c** includes a plurality of antenna elements. For example, the antenna pattern **15b** or **15c** may include an array of antenna elements. In some embodiments, the antenna pattern **15b** or **15c** may include an N×N array of antenna elements, where N is an integer greater than 1. In some embodiments, one of the antenna pattern **15b** and the antenna pattern **15c** can be omitted depending on design specifications.

[0028] As shown in FIG. 1, since the support structures **13a**, **13b** are disposed between the substrates **10** and **11** to define an air cavity, a gain, bandwidth and radiation efficiency of the antenna patterns **15a**, **15b** and **15c** can be improved by promoting resonance between the antenna pattern **15a** and the antenna pattern **15b**. To attain a desired level of resonance, a height **H11** of the air cavity (e.g. a distance between the antenna pattern **15a** and the antenna pattern **15b**) and a tolerance of the height **H11** can be controlled within a certain range. For example, the height **H11** of the air cavity can be 250 micrometers (μm) with a tolerance about $\pm 25 \mu\text{m}$, or of \pm about 22 μm , or of \pm about 19 μm .

[0029] In some comparative implementations, the support structures **13a**, **13b** can be implemented by solder (e.g. by using solder bumps). However, the dimension of the solder bumps (e.g. a height) may decrease after every reflow process. Therefore, it can be difficult to control the size of each solder bump after the reflow processes, and to control the uniformity of all the solder bumps (which can be desirable). Therefore, a large tolerance may exist for the solder bumps. For example, it may be desirable to have a height of the solder bumps correspond to the height **H11**, and the above-described issues may yield a range of variation greater than a desired range of variation (such as \pm about 30 μm or greater), which can decrease the efficiency of the resonance of the antenna patterns.

[0030] In some comparative implementations, the support structures **13a**, **13b** can be implemented by spacers. For example, a spacer is disposed between a conductive pad of the substrate **10** and a corresponding conductive pad of the

substrate 11. However, a spacer may be divided into many pieces (e.g., two or four pieces) after a singulation process if the spacer is disposed on the conductive pad that is located at the scribe line 101 as shown in FIG. 2. Since the divided spacer can have a relatively weak strength, it may be unable to provide a stable support between the substrates 10 and 11, which can be helpful in controlling the distance between the substrates 10 and 11 (e.g., controlling the height H11 of the air cavity). Further, in some embodiments, due to variations of the singulation process, the divided spacer may not be in contact with the substrate 10 and/or 11, which may affect the function of the spacer to provide a support between the substrates 10 and 11.

[0031] FIG. 3A illustrates a cross-sectional view of the support structure 13a in FIG. 1 in accordance with some embodiments of the present disclosure. The support structure 13a includes a spacer 13a1 and an adhesive layer 13a2 covering at least a portion of the spacer 13a1. Insulating layers 10s and 11s are also provided. The spacer 13a1 is disposed between the divided conductive pads 10p1 and 11p1 and in contact with a portion of the divided conductive pad 10p1 and a portion of the divided conductive pad 11p1 that is not covered by the insulating layers 10s and 11s. For example, a distance between the divided pads 10p1 and 11p1 is substantially equal to a height of the spacer 13a1. The adhesive layer 13a2 is disposed between the divided conductive pads 10p1 and 11p1 and in contact with the divided conductive pads 10p1 and 11p1. The adhesive layer 13a2 covers a portion of the spacer 13a1 that is not in contact with the divided pads 10p1 and 11p1. In some embodiments, the adhesive layer 13a2 includes solder and/or copper paste. In some embodiments, the spacer 13a1 includes a copper-cored ball or bump and/or a polymer ball or bump. In some embodiments, a material of the spacer 13a1 is chosen so that a melting point of the spacer 13a1 is higher than a temperature of a reflow process for the spacer 13a1.

[0032] In some embodiments, a roughness of a surface 10p11 (also referred to as “lateral surface”) of the divided conductive pad 10p1 is different from that of a surface 10p12 (also referred to as “top surface”) of the divided conductive pad 10p1. The lateral surface 10p11 of the divided conductive pad 10p1 may be substantially perpendicular to the top surface 10p12 of the divided conductive pad 10p1. For example, the roughness of the lateral surface 10p11 of the divided conductive pad 10p1 may be about 1.3 times or greater, about 1.5 times or greater, or about 1.8 times or greater than the roughness of the top surface 10p12 of the divided conductive pad 10p1. In some embodiments, the surface 10p11 of the divided conductive pad 10p1 is substantially coplanar with a lateral surface 103 of the substrate 10. In some embodiments, a roughness of a surface 11p11 (also referred to as “lateral surface”) of the divided conductive pad 11p1 is different from that of a surface 11p12 (also referred to as “bottom surface”) of the divided conductive pad 11p1. The lateral surface 11p11 of the divided conductive pad 11p1 may be substantially perpendicular to the top surface 11p12 of the divided conductive pad 11p1. For example, the roughness of the lateral surface 11p11 of the divided conductive pad 11p1 may be about 1.3 times or greater, about 1.5 times or greater, or about 1.8 times or greater than the roughness of the top surface 11p12 of the divided conductive pad 11p1. In some embodiments, the surface 11p11 of the divided conductive pad 11p1 is substantially coplanar with a lateral surface of the substrate 11.

[0033] In some embodiments, the support structure 13a may include more than one spacer. For example, the support structure 13a may include N spacers, where N is greater than 1. In some embodiments, as shown in FIG. 3B, the support structure 13a may include at least one spacer 13a1 that has not been divided during a singulation process and a divided spacer 13a3. A width of the divided spacer 13a3 may be, for example, about 0.9 or less, about 0.8 or less, about 0.7 or less, about 0.6 or less, or about 0.5 or less times that of the spacer 13a1. For example, a portion of the divided spacer 13a3 is removed. In some embodiments, a lateral, divided surface 13a31 of the divided spacer 13a3 is substantially coplanar with the lateral surfaces 10p11 and 11p11 of the divided conductive pads 10p1 and 11p1. By disposing at least one entire spacer (e.g., non-divided spacer or a spacer that has not been divided during the singulation process) between two corresponding divided conductive pads (e.g., the divided conductive pads 10p1 and 11p1), the support structure 13a between the substrates 10 and 11 can be reinforced, so as to precisely control a distance between the substrates 10 and 11.

[0034] FIG. 4 illustrates a cross-sectional view of the support structure 13b in FIG. 1 in accordance with some embodiments of the present disclosure. The support structure 13b includes one or more spacers 13b1 and an adhesive layer 13b2 covering at least a portion of the spacers 13b1. Insulating layers 10s1 and 11s1 are also provided. The spacers 13b1 are disposed between the non-divided conductive pads 10p2 and 11p2 and in contact with a portion of the non-divided conductive pad 10p2 and a portion of the non-divided conductive pad 11p2 that is not covered by the insulating layers 10s1 and 11s1. For example, a distance between the non-divided pads 10p2 and 11p2 is substantially equal to a height of each of the spacers 13b1. The adhesive layer 13b2 is disposed between the non-divided conductive pads 10p2 and 11p2 and in contact with the non-divided conductive pads 10p2 and 11p2. The adhesive layer 13b2 covers a portion of the spacers 13b1 that is not in contact with the non-divided pads 10p2 and 11p2. In some embodiments, the adhesive layer 13b2 includes solder and/or copper paste. In some embodiments, the spacers 13b1 include a copper-cored ball or bump and/or a polymer ball or bump. In some embodiments, the material of the spacers 13b1 is chosen so that a melting point of the spacers 13b1 is higher than a temperature of a reflow process for the spacers 13b1.

[0035] FIG. 5A, FIG. 5B, FIG. 5C, FIG. 5D and FIG. 5E are cross-sectional views of a semiconductor structure at various stages of fabrication, in accordance with some embodiments of the present disclosure. Various figures have been simplified to provide a better understanding of the aspects of the present disclosure. In some embodiments, the structures shown in FIG. 5A, FIG. 5B, FIG. 5C, FIG. 5D and FIG. 5E are used to manufacture the support structures 13a, 13b shown in FIG. 1, FIG. 3A and FIG. 3B.

[0036] Referring to FIG. 5A, a substrate 10 having an antenna pattern 15a and conductive pads 10p1' and 10p2 is provided. The substrate 10 includes an insulation layer 10s (e.g., a solder mask) covering a portion of the conductive pads 10p1' and 10p2. As shown in FIG. 5A, one or more recesses are defined by the insulation layer 10s and the conductive pads 10p1' and 10p2.

[0037] Referring to FIG. 5B, a paste 53 (or soldering paste) is formed within the one or more recesses defined by the insulation layer 10s and the conductive pads 10p1' and

10p2. In some embodiments, the paste **53** includes a plurality of spacers **53a** and an adhesive layer **53b** covering the spacers **53a**. In some embodiments, a total volume of the spacers **53a** is more than about 2% of a volume of the paste **53** (e.g. about 3% or more of the volume of the paste **53**, about 4% or more of the volume of the paste **53**, or about 5% or more of the volume of the paste **53**), and a total volume of the adhesive layer **53b** is less than about 98% of the volume of the paste **53** (e.g. about 97% or less of the volume of the paste **53**, about 96% or less of the volume of the paste **53**, or about 95% or less of the volume of the paste **53**).

[0038] In some embodiments, the paste **53** can be formed by printing process. For example, as shown in FIG. **5C**, a stencil **59** is disposed on the insulation layer **10s**. The stencil **59** defines an opening corresponding to at least one of the one or more recesses defined by the insulation layer **10s** and the conductive pads **10p1'** and **10p2**. A size (e.g. a width) of each of the spacers **53a** is less than a diameter of the opening of the stencil **59** (e.g. a ratio of the diameter of the opening of the stencil **59** to a diameter of each respective spacer **53a** is at least equal to or greater than about 6.8 times the size of each spacer **53a**, such as about 7.8 or more times larger than the size of each spacer **53a**, about 9.8 or more times larger than the size of each spacer **53a**, or greater), and is less than a diameter of the one or more recesses defined by the insulation layer **10s** and the conductive pads **10p1'** and **10p2** (e.g. the size of each of the spacers **53a** is less than about 0.5 times the diameter of the one or more recesses defined by the insulation layer **10s** and the conductive pads **10p1'** and **10p2**, less than about 0.4 times the diameter of the one or more recesses defined by the insulation layer **10s** and the conductive pads **10p1'** and **10p2**, or less than about 0.3 times the diameter of the one or more recesses defined by the insulation layer **10s** and the conductive pads **10p1'** and **10p2**), and each recess may accommodate a plurality of spacers **53a**.

[0039] Referring to FIG. **5D**, a substrate **11** is disposed over the substrate **10** and in contact with the paste **53**. The substrate **11** includes antenna patterns **15b** and **15c** corresponding to the antenna pattern **15a**. The substrate **11** has conductive pads **11p1'** and **11p2** corresponding to the conductive pads **10p1'** and **10p2**. The paste **53** is in contact with a portion of the conductive pads **11p1'** and **11p2** that is not covered by the insulation layer **11s**. Then, the paste **53** is heated to form the support structure **13** as shown in FIG. **1**. For example, the spacers **53a**, the adhesive layer **53b**, the substrates **10**, **11** and the conductive pads **10p1'**, **10p2**, **11p1'** and **11p2** are cured.

[0040] Referring to FIG. **5E**, a singulation process is carried out to separate out individual semiconductor package devices. That is, the singulation is performed through a substrate strip including the substrates **10**, **11**. The singulation is also performed through the conductive pads **10p1'** and **11p1'** to form divided conductive pads **10p1** and **11p1**. The singulation may be performed, for example, by using a dicing saw, laser or other appropriate cutting technique.

[0041] FIG. **6** shows a semiconductor package device **6** according to some embodiments of the present disclosure. The semiconductor package device **6** includes a substrate **10**, an antenna pattern **15a** disposed on the substrate **10**, a substrate **11**, an antenna layer **15c** disposed on the substrate **11**, and a stand-off (or other support) structure **530** disposed between the substrate **10** and the substrate **11** to define an air cavity therebetween. In some embodiments, the stand-off

structure **530** includes an array of polymer spacers along with an adhesive (e.g., an epoxy resin or other resin) to provide adhesion to the substrate **10** and the substrate **11**. Advantages of the semiconductor package device **6** include a well-controlled air cavity height, such as where a height of the polymer spacers can be controlled to $250\ \mu\text{m}\pm 10\ \mu\text{m}$ (e.g. to $250\ \mu\text{m}\pm 8\ \mu\text{m}$, or $250\ \mu\text{m}\pm 6\ \mu\text{m}$), and high-throughput placement of the polymer spacers and the adhesive by a dispensing process. The polymer spacers and the adhesive are disposed in gaps between regions of the antenna pattern **15a**, and cross-sectional widths of the polymer spacers and the adhesive vary according to different widths of the gaps. In some embodiment, the semiconductor package device **6** further includes an adhesive material formed on the substrate **10** around the polymer spacers.

[0042] In some embodiments, the stand-off structure **530** may include an array of polymer spacers along with a die attach film (DAF) to provide adhesion to the substrate **10** and the substrate **11**. Advantages of the use of the DAF as the stand-off structure **530** include a well-controlled air cavity height, such as where a height of the polymer spacers can be controlled to $250\ \mu\text{m}\pm 10\ \mu\text{m}$ (e.g. to $250\ \mu\text{m}\pm 8\ \mu\text{m}$, or $250\ \mu\text{m}\pm 6\ \mu\text{m}$), and a low degree of bleeding of a material of the DAF to mitigate against contamination of the antenna pattern **15a**. The polymer spacers and the DAF are disposed in gaps between regions of the antenna pattern **15a**, and cross-sectional widths of the polymer spacers and the DAF varies according to different widths of the gaps.

[0043] In some embodiments, the stand-off structure **530** may include an array of polymer cores surrounded by a solder to provide adhesion to the substrate **10** and the substrate **11**. Advantages of the use of the polymer cores surrounded by the solder include a well-controlled air cavity height, such as where a height of the polymer cores can be controlled to $250\ \mu\text{m}\pm 10\ \mu\text{m}$ (e.g. to $250\ \mu\text{m}\pm 8\ \mu\text{m}$, or $250\ \mu\text{m}\pm 6\ \mu\text{m}$), and high-throughput placement of the polymer cores and the solder by a ball or bump mounting process. The polymer cores and the solder are disposed in gaps between regions of the antenna pattern **15a**, and cross-sectional widths of the polymer cores and the solder vary according to different widths of the gaps.

[0044] In some embodiments, the stand-off structure **530** may include an array of conductive posts (e.g., copper (Cu) pillars) and a solder to provide adhesion. Advantages of the use of the conductive posts include a well-controlled air cavity height, such as where a height of the conductive posts can be controlled to $250\ \mu\text{m}\pm 10\ \mu\text{m}$ (e.g. to $250\ \mu\text{m}\pm 8\ \mu\text{m}$, or $250\ \mu\text{m}\pm 6\ \mu\text{m}$), and high-throughput manufacturing by a solder paste printing process. The conductive posts are disposed in gaps between regions of the antenna pattern **15a**, and cross-sectional widths of the conductive posts vary according to different widths of the gaps.

[0045] FIG. **7** illustrates a semiconductor package device **7** according to some embodiments of the present disclosure. The semiconductor package device **7** includes a substrate **70** including a base portion **70a** and an extension portion **70b** protruding upwardly from the base portion **70a**, an antenna pattern **15a** disposed on the substrate **10**, a substrate **11** disposed on the extension portion **70b** of the substrate **70** via a solder paste **71** to define an air cavity between the substrate **70** and the substrate **11**, and an antenna layer **15c** disposed on the substrate **11**. Advantages of the semiconductor package device **7** include a well-controlled air cavity height, such as where the height of the cavity can be controlled to 250

$\mu\text{m}\pm 10\ \mu\text{m}$ (e.g. to $250\ \mu\text{m}\pm 8\ \mu\text{m}$, or $250\ \mu\text{m}\pm 6\ \mu\text{m}$), and a low degree of bleeding of a material of the extension portion to mitigate against contamination of the antenna pattern **15a**. In some embodiments, the semiconductor package device **7** further includes an adhesive material formed on the substrate **70** around the extension portion **70b** of the substrate **70**.

[0046] FIG. **8A** and FIG. **8B** are cross-sectional views of a semiconductor structure at various stages of fabrication, in accordance with some embodiments of the present disclosure. Various figures have been simplified to provide a better understanding of the aspects of the present disclosure. In some embodiments, the structures shown in FIG. **8A** and FIG. **8B** are used to manufacture the semiconductor package device **7** shown in FIG. **7**.

[0047] Referring to FIG. **8A**, the substrate **70** including the base portion **70a** and the extension portion **70b** protruding upwardly from the base portion **70a**. The antenna pattern **15a** is formed on the substrate **10**. A printing process is performed on the extension portion **70b** of the substrate **70** to apply the solder paste **71**.

[0048] Referring to FIG. **8B**, the substrate **11** (e.g. already singulated) is disposed on the extension portion **70b** of the substrate **70** by a pick and place tool, and a solder reflow process is performed to form the semiconductor package device **7** shown in FIG. **7**. Although the cavity is shown as being formed in the substrate **70**, in other embodiments the cavity can be formed in the substrate **11**.

[0049] FIG. **9** illustrates a semiconductor package device **9** according to some embodiments of the present disclosure. The semiconductor package device **9** includes a substrate **10**, an antenna pattern **15a** disposed on the substrate **10**, a substrate **90** including a base portion **90a** and an extension portion **90b** protruding downwardly from the base portion **90a** and disposed on the substrate **10** to define an air cavity between the substrate **10** and the substrate **90**, an adhesive **91** (e.g., an epoxy resin or other resin) to provide adhesion between the substrate **10** and the substrate **90**, and an antenna layer **15c** disposed on the substrate **90**. In some embodiments, the substrate **90** can be formed of, or can include, glass, silicon, or other dielectric material having a low dielectric constant. In some embodiments, a solder can be used in place of, or in conjunction with, the adhesive **91**. Advantages of the semiconductor package device **9** include a well-controlled air cavity height, such as where the height of the cavity can be controlled to $250\ \mu\text{m}\pm 10\ \mu\text{m}$ (e.g. to $250\ \mu\text{m}\pm 8\ \mu\text{m}$, or $250\ \mu\text{m}\pm 6\ \mu\text{m}$), and a low degree of bleeding of a material of the extension portion **90b** to mitigate against contamination of the antenna pattern **15a**. In some embodiments, the semiconductor package device **9** further includes an adhesive material formed on the substrate **10** around the extension portion **90b** of the substrate **90**.

[0050] FIG. **10A**, FIG. **10B**, FIG. **10C** and FIG. **10D** are cross-sectional views of a semiconductor structure at various stages of fabrication, in accordance with some embodiments of the present disclosure. Various figures have been simplified to provide a better understanding of the aspects of the present disclosure. In some embodiments, the structures shown in FIG. **10A**, FIG. **10B**, FIG. **10C** and FIG. **10D** are used to manufacture the semiconductor package device **9** shown in FIG. **9**.

[0051] Referring to FIG. **10A**, a substrate **90'** is provided and the antenna pattern **15c** is formed on a surface **901** of the substrate **90'**. In some embodiments, the substrate **90'** can be

formed of, or can include, glass, silicon, or other material having a low dielectric constant.

[0052] Referring to FIG. **10B**, cavities **90h** are formed in a surface **902** of the substrate **90'** into the substrate **90**, such as by etching or other removal processes.

[0053] Referring to FIG. **10C**, the substrate **90'** is singulated to form individual substrates **90** including the base portion **90a** and the extension portion **90b**.

[0054] Referring to FIG. **10D**, the substrate **10** including the antenna layer **15a** formed thereon is provided. The adhesive **91** is disposed on the substrate **10**, such as by a printing process or other dispensing process. The substrate **90** formed in the operation shown in FIG. **10C** is disposed on the substrate **10** by a pick and place tool. Then the adhesive **91** is cured, such as by applying ultraviolet radiation or heat, to form the semiconductor package device **9** shown in FIG. **9**.

[0055] As used herein, the terms “approximately,” “substantially,” and “about” are used to describe and account for small variations. When used in conjunction with an event or circumstance, the terms can refer to instances in which the event or circumstance occurs precisely as well as instances in which the event or circumstance occurs to a close approximation. For example, when used in conjunction with a numerical value, the terms can refer to a range of variation less than or equal to $\pm 10\%$ of that numerical value, such as less than or equal to $\pm 5\%$, less than or equal to $\pm 4\%$, less than or equal to $\pm 3\%$, less than or equal to $\pm 2\%$, less than or equal to $\pm 1\%$, less than or equal to $\pm 0.5\%$, less than or equal to $\pm 0.1\%$, or less than or equal to $\pm 0.05\%$. For example, two numerical values can be deemed to be “substantially” or “about” the same if a difference between the values is less than or equal to $\pm 10\%$ of an average of the values, such as less than or equal to $\pm 5\%$, less than or equal to $\pm 4\%$, less than or equal to $\pm 3\%$, less than or equal to $\pm 2\%$, less than or equal to $\pm 1\%$, less than or equal to $\pm 0.5\%$, less than or equal to $\pm 0.1\%$, or less than or equal to $\pm 0.05\%$. For example, “substantially” parallel can refer to a range of angular variation relative to 0° that is less than or equal to $\pm 10^\circ$, such as less than or equal to $\pm 5^\circ$, less than or equal to $\pm 4^\circ$, less than or equal to $\pm 3^\circ$, less than or equal to $\pm 2^\circ$, less than or equal to $\pm 1^\circ$, less than or equal to $\pm 0.5^\circ$, less than or equal to $\pm 0.1^\circ$, or less than or equal to $\pm 0.05^\circ$. For example, “substantially” perpendicular can refer to a range of angular variation relative to 90° that is less than or equal to $\pm 10^\circ$, such as less than or equal to $\pm 5^\circ$, less than or equal to $\pm 4^\circ$, less than or equal to $\pm 3^\circ$, less than or equal to $\pm 2^\circ$, less than or equal to $\pm 1^\circ$, less than or equal to $\pm 0.5^\circ$, less than or equal to $\pm 0.1^\circ$, or less than or equal to $\pm 0.05^\circ$.

[0056] Two surfaces can be deemed to be coplanar or substantially coplanar if a displacement between the two surfaces is no greater than $5\ \mu\text{m}$, no greater than $2\ \mu\text{m}$, no greater than $1\ \mu\text{m}$, or no greater than $0.5\ \mu\text{m}$.

[0057] As used herein, the terms “conductive,” “electrically conductive” and “electrical conductivity” refer to an ability to transport an electric current. Electrically conductive materials typically indicate those materials that exhibit little or no opposition to the flow of an electric current. One measure of electrical conductivity is Siemens per meter (S/m). Typically, an electrically conductive material is one having a conductivity greater than approximately $10^4\ \text{S/m}$, such as at least $10^5\ \text{S/m}$ or at least $10^6\ \text{S/m}$. The electrical conductivity of a material can sometimes vary with tem-

perature. Unless otherwise specified, the electrical conductivity of a material is measured at room temperature.

[0058] As used herein, the singular terms “a,” “an,” and “the” may include plural referents unless the context clearly dictates otherwise. In the description of some embodiments, a component provided “on” or “over” another component can encompass cases where the former component is directly on (e.g., in physical contact with) the latter component, as well as cases where one or more intervening components are located between the former component and the latter component.

[0059] While the present disclosure has been described and illustrated with reference to specific embodiments thereof, these descriptions and illustrations do not limit the present disclosure. It can be clearly understood by those skilled in the art that various changes may be made, and equivalent components may be substituted within the embodiments without departing from the true spirit and scope of the present disclosure as defined by the appended claims. The illustrations may not necessarily be drawn to scale. There may be distinctions between the artistic renditions in the present disclosure and the actual apparatus, due to variables in manufacturing processes and such. There may be other embodiments of the present disclosure which are not specifically illustrated. The specification and drawings are to be regarded as illustrative rather than restrictive. Modifications may be made to adapt a particular situation, material, composition of matter, method, or process to the objective, spirit and scope of the present disclosure. All such modifications are intended to be within the scope of the claims appended hereto. While the methods disclosed herein have been described with reference to particular operations performed in a particular order, it can be understood that these operations may be combined, sub-divided, or re-ordered to form an equivalent method without departing from the teachings of the present disclosure. Therefore, unless specifically indicated herein, the order and grouping of the operations are not limitations of the present disclosure.

What is claimed is:

1. A semiconductor package device, comprising:
 - a first substrate including a first pad;
 - a second substrate including a second pad disposed above the first pad;
 - a first spacer disposed between the first pad and the second pad; and
 - an adhesive layer covering the first spacer and in contact with the first pad and the second pad.
2. The semiconductor package device of claim 1, wherein the first pad and the second pad are truncated pads.
3. The semiconductor package device of claim 1, wherein the first pad has a top surface facing the second pad and a lateral surface substantially perpendicular to the top surface, and a roughness of the top surface of the first pad is different from a roughness of the lateral surface of the first pad.
4. The semiconductor package device of claim 1, wherein a lateral surface of the first pad is substantially coplanar with a lateral surface of the first substrate, and a lateral surface of the second pad is substantially coplanar with a lateral surface of the second substrate.
5. The semiconductor package device of claim 1, further comprising a second spacer disposed between the first pad and the second pad, wherein a width of the second spacer is smaller than a width of the first spacer.

6. The semiconductor package device of claim 5, wherein the second spacer has a truncated surface substantially coplanar with a lateral surface of the first pad or a lateral surface of the second pad.

7. The semiconductor package device of claim 1, wherein a distance between the first pad and the second pad is substantially equal to a height of the first spacer.

8. The semiconductor package device of claim 1, further comprising:

- a first insulating layer disposed on the first pad and exposing a portion of the first pad; and
- a second insulating layer disposed on the second divided pad and exposing a portion of the second pad, wherein the first insulating layer or the second insulating layer is in contact with the adhesive layer.

9. The semiconductor package device of claim 1, further comprising:

- a first insulating layer disposed on the first pad and exposing a portion of the first pad; and
- a second insulating layer disposed on the second divided pad and exposing a portion of the second pad, wherein the first insulating layer or the second insulating layer is spaced apart from the adhesive layer.

10. A semiconductor package device, comprising:

- a first substrate including a first pad;
- a second substrate including a second pad disposed corresponding to the first pad; and
- a support structure disposed between the first pad and the second pad, wherein a lateral surface of the support structure is substantially coplanar with a lateral surface of the first pad of the first substrate and a lateral surface of the second pad of the second substrate.

11. The semiconductor package device of claim 10, wherein the first pad and the second pad are truncated pads.

12. The semiconductor package device of claim 10, wherein the first pad has a top surface facing the second pad and a lateral surface substantially perpendicular to the top surface, and a roughness of the top surface of the first pad is different from a roughness of the lateral surface of the first pad.

13. The semiconductor package device of claim 10, wherein the support structure includes a spacer, an adhesive layer or a combination thereof.

14. The semiconductor package device of claim 10, wherein a distance between the first pad and the second pad is substantially equal to a height of the support structure.

15. The semiconductor package device of claim 10, wherein a melting point of the support structure is higher than a temperature of a reflow process for the support structure.

16. A semiconductor package device, comprising:

- a first substrate including a first truncated pad;
- a second substrate including a second truncated pad disposed corresponding to the first truncated pad; and
- a support structure disposed between the first truncated pad and the second truncated pad.

17. The semiconductor package device of claim 16, wherein the first truncated pad has a top surface facing the second truncated pad and a lateral surface substantially perpendicular to the top surface, and a roughness of the top surface of the first truncated pad is different from a roughness of the lateral surface of the first truncated pad.

18. The semiconductor package device of claim **16**, wherein the support structure includes a spacer, an adhesive layer or a combination thereof.

19. The semiconductor package device of claim **16**, wherein a melting point of the support structure is higher than a temperature of a reflow process for the support structure.

20. The semiconductor package device of claim **16**, wherein the support structure is in contact with the first truncated pad and the second truncated pad.

* * * * *