

(12) **United States Patent**
Orsini et al.

(10) **Patent No.:** **US 11,780,617 B2**
(45) **Date of Patent:** **Oct. 10, 2023**

(54) **FLEXIBLE PACKAGE CONVEYANCE**

(71) Applicant: **Sealed Air Corporation (US)**,
Charlotte, NC (US)

(72) Inventors: **Thomas Orsini**, Sterling, MA (US);
Mark Garceau, Bethlehem, CT (US);
David Cenedella, Shirley, MA (US);
Robert Simonelli, Worcester, MA (US);
Michael Kalinowski, Nashua, NH
(US); **Kyle Brown**, Frisco, TX (US);
John Gilbert, Lowell, MA (US)

(73) Assignee: **Sealed Air Corporation (US)**,
Charlotte, NC (US)

(*) Notice: Subject to any disclaimer, the term of this
patent is extended or adjusted under 35
U.S.C. 154(b) by 0 days.

(21) Appl. No.: **17/851,121**

(22) Filed: **Jun. 28, 2022**

(65) **Prior Publication Data**

US 2022/0324597 A1 Oct. 13, 2022

Related U.S. Application Data

(62) Division of application No. 16/465,604, filed as
application No. PCT/US2017/061432 on Nov. 14,
2017, now Pat. No. 11,401,061.

(Continued)

(51) **Int. Cl.**

B65B 9/067 (2012.01)
B65B 31/04 (2006.01)

(Continued)

(52) **U.S. Cl.**

CPC **B65B 9/067** (2013.01); **B65B 31/04**
(2013.01); **B65B 51/10** (2013.01); **B65D 75/38**
(2013.01); **B65D 2205/02** (2013.01)

(58) **Field of Classification Search**

CPC B65D 2205/00-04; B65D 75/38; B65B
9/067; B65B 9/06; B65B 51/10
See application file for complete search history.

(56) **References Cited**

U.S. PATENT DOCUMENTS

2,160,367 A * 5/1939 Maxfield B65B 31/045
53/511
3,237,844 A * 3/1966 Hughes B65D 33/01
383/103

(Continued)

FOREIGN PATENT DOCUMENTS

EP 0755875 A1 1/1997
GB 2424849 A1 10/2006

(Continued)

Primary Examiner — Anna K Kinsaul

Assistant Examiner — Himchan Song

(74) *Attorney, Agent, or Firm* — Jon M. Isaacson

(57) **ABSTRACT**

A system for enhanced conveying of flexible packages includes a packaging system, an inflation system, and a conveying system. The packaging system is configured to place an object in a flexible package. The inflation system is configured to insert a gas into the flexible package. The packaging system is further configured to seal an edge of the flexible package in an inflated state with the object and the inserted gas inside the flexible package. The conveying system is configured to convey the flexible package while the flexible package is substantially in the inflated state. The flexible package is configured to permit gas to escape the flexible package at a controlled flow rate such that the flexible package remains substantially in the inflated state while being conveyed by the conveying system and the flexible package transitions to being substantially in a deflated state after being conveyed by the conveying system.

10 Claims, 7 Drawing Sheets

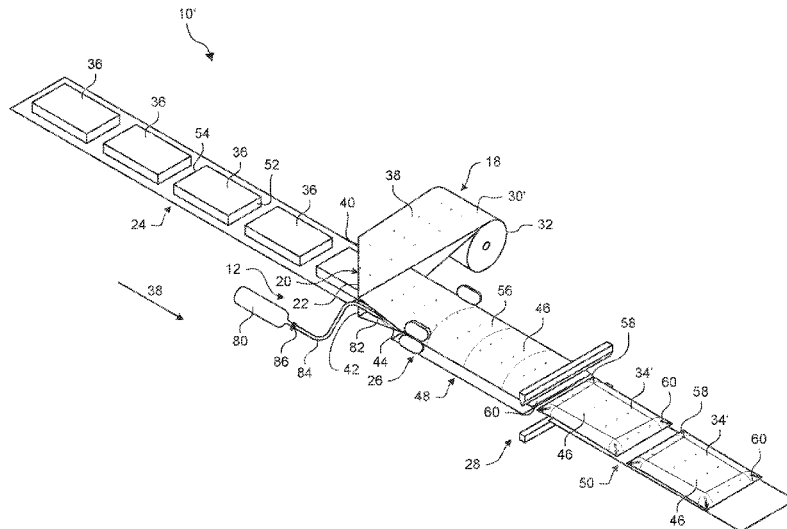

Related U.S. Application Data

(60) Provisional application No. 62/429,129, filed on Dec. 2, 2016.

(51) **Int. Cl.**

B65B 51/10 (2006.01)

B65D 75/38 (2006.01)

(56)

References Cited

U.S. PATENT DOCUMENTS

3,579,945 A * 5/1971 Buchner B65B 31/045
53/511
3,664,086 A * 5/1972 James B65B 55/19
53/511
4,219,988 A 9/1980 King et al.
8,087,827 B2 1/2012 Mir
2008/0237316 A1 10/2008 Ogino et al.
2010/0257820 A1* 10/2010 Doll B65B 31/04
53/511
2013/0322790 A1 12/2013 Su et al.
2014/0123599 A1 5/2014 Gustafsson et al.
2018/0141686 A1 5/2018 Christman et al.
2019/0191940 A1* 6/2019 Ishikawa B65B 9/087

FOREIGN PATENT DOCUMENTS

WO 2015150719 A1 10/2015
WO 2016179204 A1 11/2016

* cited by examiner

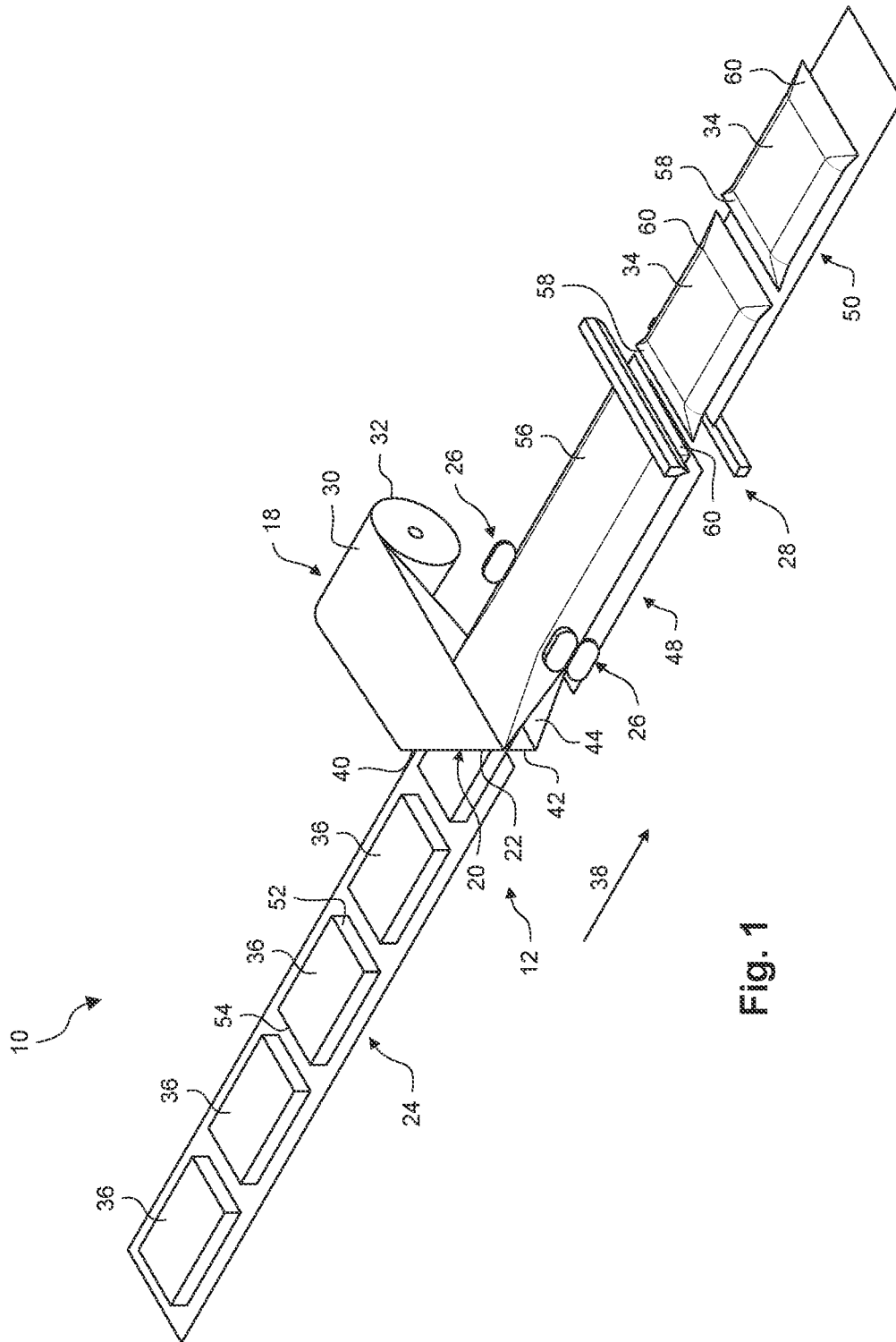

Fig. 1

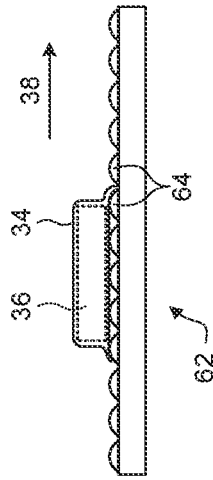

Fig. 2A

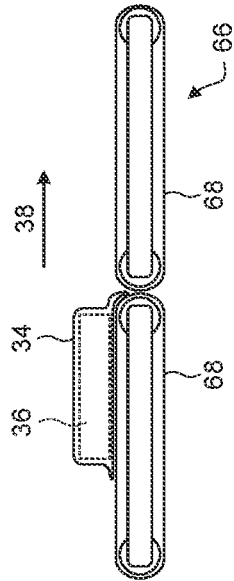

Fig. 2B

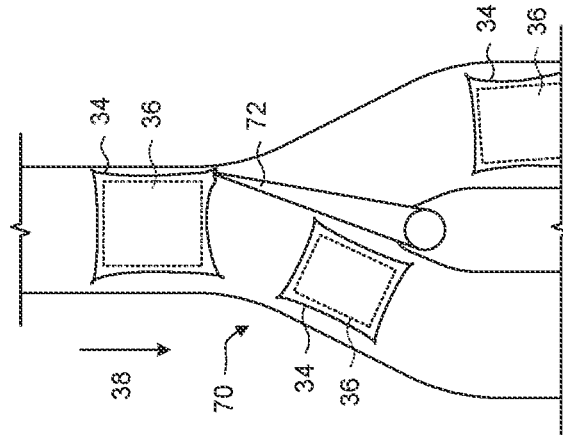

Fig. 2C

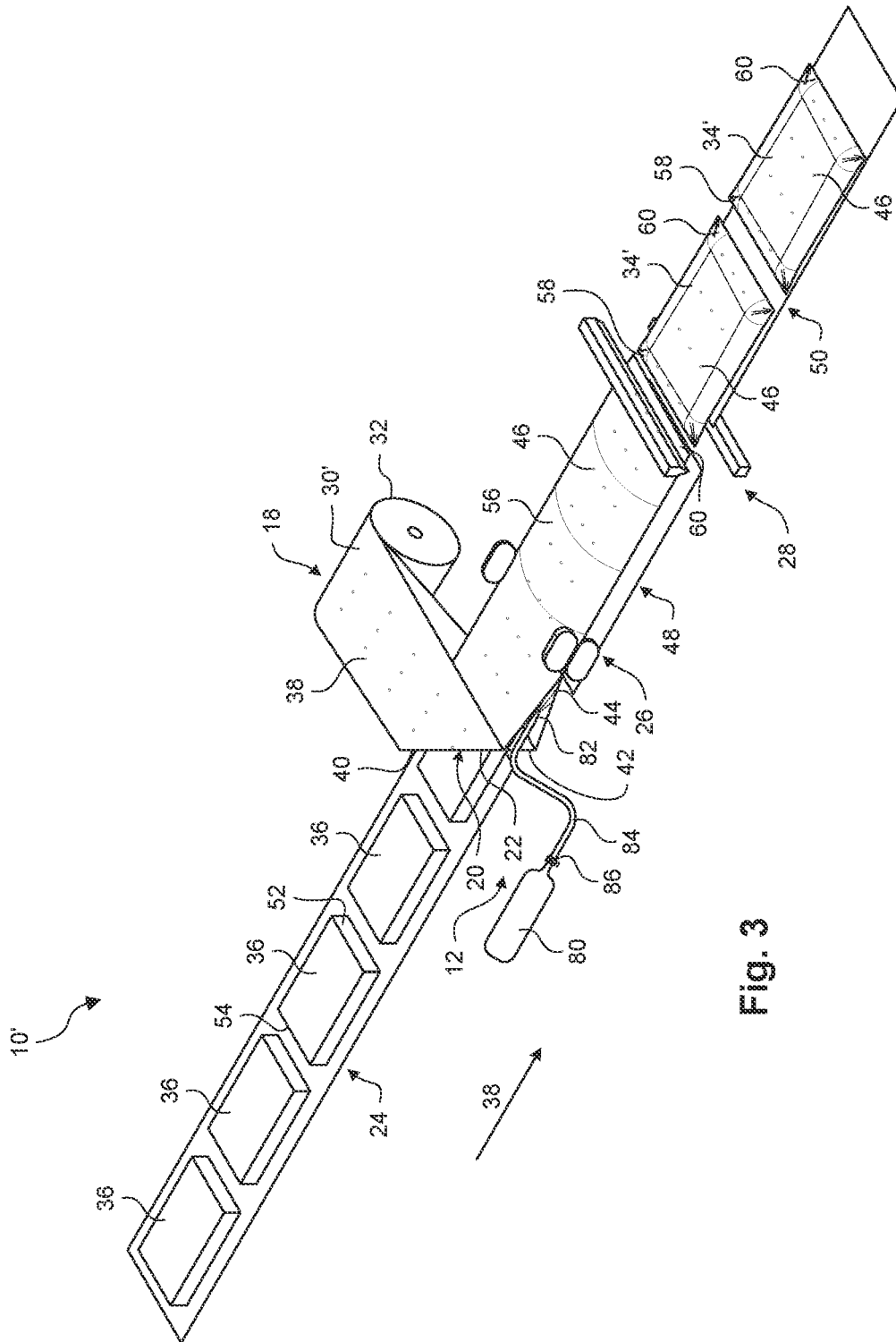

Fig. 3

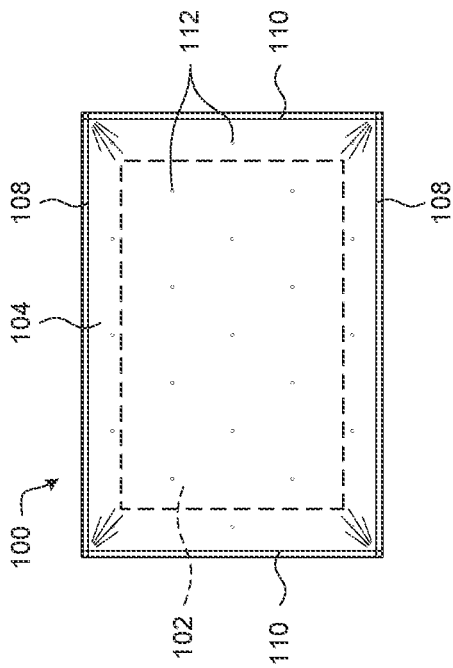

FIG. 4A

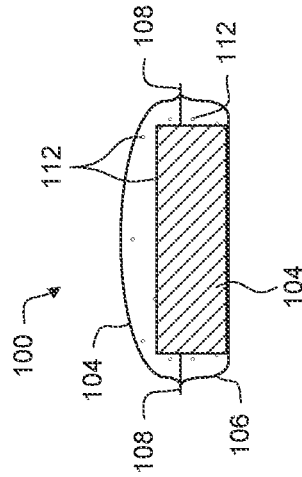

FIG. 4C

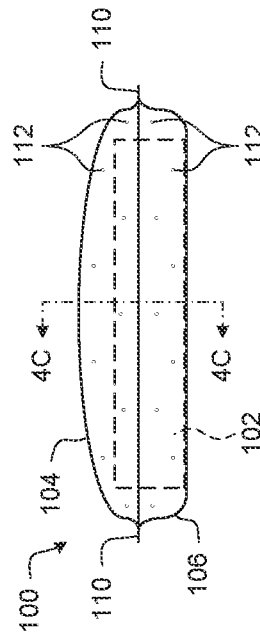

FIG. 4B

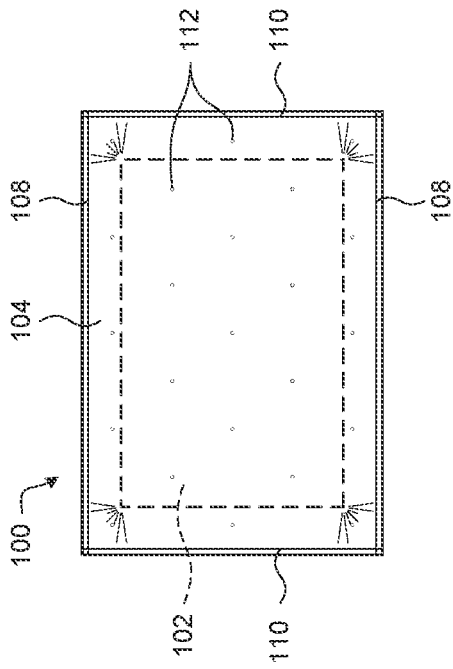

Fig. 5A

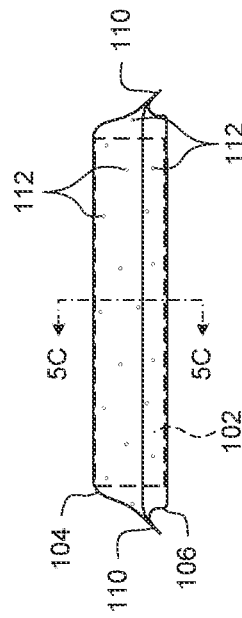

Fig. 5B

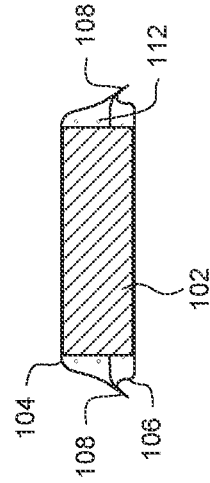

Fig. 5C

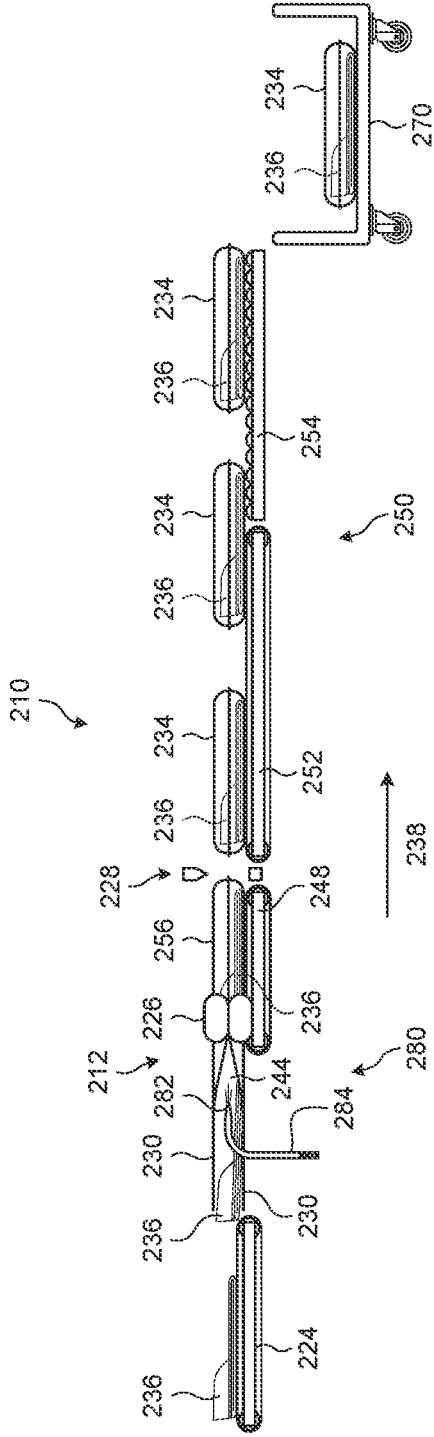

Fig. 6

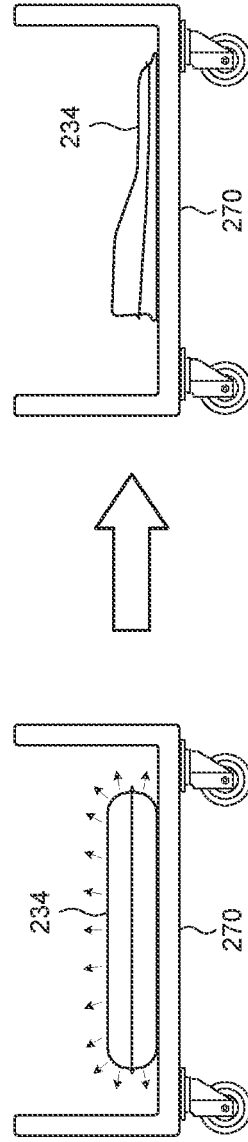

Fig. 7

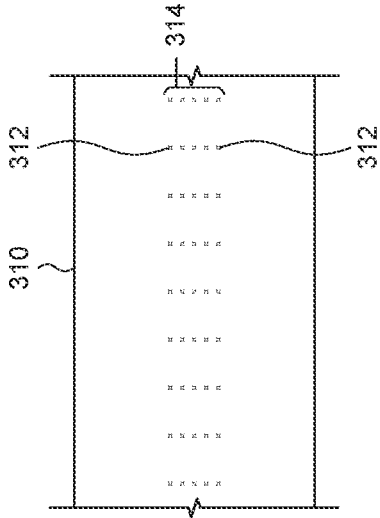

Fig. 8B

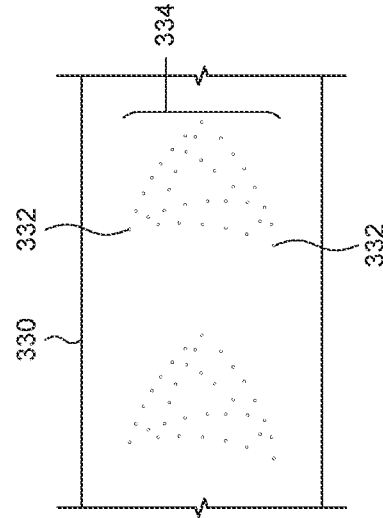

Fig. 8D

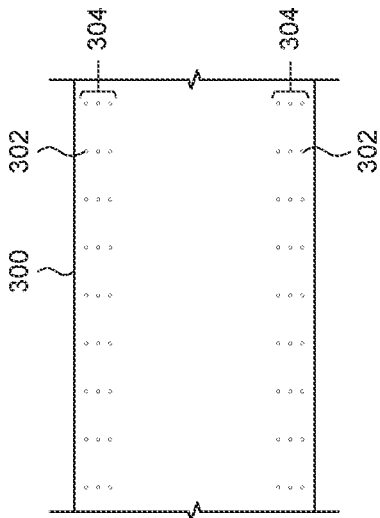

Fig. 8A

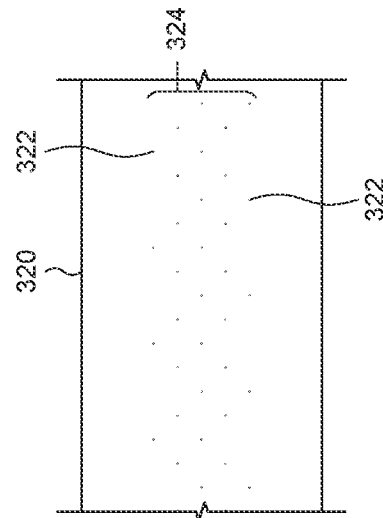

Fig. 8C

FLEXIBLE PACKAGE CONVEYANCE**CROSS REFERENCE TO RELATED APPLICATIONS**

This application is a divisional of U.S. patent application Ser. No. 16/465,604, filed May 31, 2019, which is a national stage entry of International Application No. PCT/US2017/061432, filed Nov. 14, 2017, which claims the benefit of U.S. Provisional Patent Application No. 62/429,129, filed Dec. 2, 2016, the contents of each of which are hereby incorporated by reference in their entirety.

BACKGROUND

The present disclosure is in the technical field of preparing flexible packages for shipping. More particularly, the present disclosure is directed to inflating flexible packages for conveyance in a shipping facility.

Objects are regularly packaged and shipped in flexible packages, such as bags formed from polyethylene film. Objects can be packaged in a continuous flow of objects in a continuous flow wrap machine. Examples of such continuous flow wrap machines are described, for example, in U.S. Pat. No. 4,219,988 and are available from Sealed Air Corporation (Charlotte, N.C.) under the Shanklin FloWrap Series trademark. Once the objects are packaged in the flexible packages, the packages can be prepared for shipping, such as by adhering a shipping label to the exterior of the flexible package, and then shipped, such as by delivering the flexible package to a shipping company. The flexible packages provide a container for certain objects because they are lightweight and provide protection from being damaged or dirtied during shipment.

SUMMARY

This summary is provided to introduce a selection of concepts in a simplified form that are further described below in the Detailed Description. This summary is not intended to identify key features of the claimed subject matter, nor is it intended to be used as an aid in determining the scope of the claimed subject matter.

A method includes placing an object in a flexible package, inserting gas into the flexible package, sealing an edge of the flexible package in an inflated state with the object and the inserted gas inside the flexible package, and conveying the flexible package after sealing the edge of the flexible package in the inflated state. The flexible package includes one or more vent holes configured to permit gas to exit the flexible package. At least one characteristic of the one or more vent holes is selected to control a flow rate of gas exiting the flexible package such that the flexible package remains substantially in the inflated state during the conveying and such that the flexible package transitions to being substantially in a deflated state after the conveying is complete.

In one example, the method further includes shipping the flexible package from a shipping facility after the flexible package has transitioned to being substantially in the deflated state. In another example, the placing, the inserting, the sealing, and the conveying occur in the shipping facility. In another example, the at least one characteristic includes one or more of a size of the one or more vent holes, a shape of the one or more vent holes, a number of the one or more vent holes, a location of the one or more vent holes, or a pattern of the one or more vent holes.

In another example, the pressure inside of the flexible package is at least 1 higher than pressure outside of the flexible package when the flexible package is in the inflated state and when the flexible package is substantially in the inflated state. In another example, the pressure inside of the flexible package is in a range from 1% to 10% higher than the pressure outside of the flexible package when the flexible package is in the inflated state and when the flexible package is substantially in the inflated state. In another example, the pressure inside of the flexible package is in a range between the pressure outside of the flexible package and a pressure that is 0.2% higher than the pressure outside of the flexible package when the flexible package is substantially in the deflated state. In another example, the pressure inside of the flexible package is at least 2.5 kPa above atmospheric pressure when the flexible package is in the inflated state and when the flexible package is substantially in the inflated state. In another example, the pressure inside of the flexible package is in a range between the pressure outside of the flexible package and a pressure that is 0.5 kPa higher than the pressure outside of the flexible package when the flexible package is substantially in the deflated state. In another example, when the flexible package is in the inflated state and when the flexible package is substantially in the inflated state, a top portion of the flexible package does not contact a top portion of the object. In another example, when the flexible package is substantially in the deflated state, the top portion of the flexible package is in contact with the top portion of the object.

In another example, inserting gas into the flexible package comprises directing a flow of gas from a gas source toward an open end of the flexible package. In another example, sealing the edge of the flexible package comprises sealing the open end of the flexible package while the flow of gas is being directed toward the open end of the flexible package. In another example, the at least one characteristic of the one or more vent holes is selected to provide the flexible package with a type of functionality. In another example, the type of functionality includes at least one of aid in opening of the flexible package, prevention of damage to the flexible package, or improved ability to reuse the flexible package.

In another embodiment, a system includes a packaging system configured to place an object in a flexible package and an inflation system configured to insert a gas into the flexible package. The packaging system is further configured to seal an edge of the flexible package in an inflated state with the object and the inserted gas inside the flexible package. The system further includes a conveying system configured to convey the flexible package while the flexible package is substantially in the inflated state. The flexible package is configured to permit gas to escape the flexible package at a controlled flow rate such that the flexible package remains substantially in the inflated state while being conveyed by the conveying system and such that the flexible package transitions to being substantially in a deflated state after being conveyed by the conveying system.

In one example, the system is located in a shipping facility and the flexible package is configured to be shipped from the shipping facility when the flexible package is substantially in the deflated state. In another example, the system further includes a film dispenser configured to supply film to the packaging system, wherein the packaging system is configured to form the flexible package from the film. In another example, the film includes one or more vent holes configured to permit the gas to escape the flexible package. In another example, at least one characteristic of the one or more vent holes is selected to control the controlled flow rate

of the gas out of the flexible package. In another example, the at least one characteristic includes one or more of a size of the one or more vent holes, a shape of the one or more vent holes, a number of the one or more vent holes, a location of the one or more vent holes, or a pattern of the one or more vent holes. In another example, the at least one characteristic of the one or more vent holes is selected to provide the flexible package with a type of functionality. In another example, the type of functionality includes at least one of aid in opening of the flexible package, prevention of damage to the flexible package, or improved ability to reuse the flexible package. In another example, the conveying system includes one or more of a conveyor belt or a plurality of rollers. In another example, the inflation system includes a source of pressurized gas and the source of pressurized gas includes one or more of a container of pressurized gas or a gas compressor.

BRIEF DESCRIPTION OF THE DRAWING

The foregoing aspects and many of the attendant advantages of the disclosed subject matter will become more readily appreciated as the same become better understood by reference to the following detailed description, when taken in conjunction with the accompanying drawings, wherein:

FIG. 1 depicts an embodiment of a system that includes a packaging system, in accordance with the embodiments described herein;

FIGS. 2A to 2C depict examples of possible failures of the flexible packages during conveyance, in accordance with the embodiments described herein;

FIG. 3 depicts an embodiment of a system that is a variation of the system depicted in FIG. 1, in accordance with the embodiments described herein;

FIGS. 4A, 4B, and 4C depict, respectively, top, side, and end cross-sectional views of a flexible package in an inflated state, in accordance with the embodiments described herein;

FIGS. 5A, 5B, and 5C depict, respectively, top, side, and end cross-sectional views of the flexible package shown in FIGS. 4A to 4C in substantially in a deflated state, in accordance with the embodiments described herein;

FIG. 6 depicts an embodiment of a system that includes a packaging system, an inflation system, and a conveying system, in accordance with the embodiments described herein;

FIG. 7 depicts an example of gas exiting a flexible package exiting until the flexible package is substantially in a deflated state, in accordance with the embodiments described herein; and

FIGS. 8A to 8D depict embodiments of films having vent holes with different characteristics, in accordance with the embodiments described herein.

DETAILED DESCRIPTION

The present disclosure describes embodiments of systems and methods of inflating flexible packages for conveyance in a shipping facility. In particular, in embodiments described herein, an object is placed in a flexible package and gas is inserted into a flexible package. The flexible package is sealed such that the flexible package is in an inflated state. After the flexible package is sealed, it is conveyed through the shipping facility until it is at a location where it awaits shipping out of the shipping facility. The flexible package is configured to permit gas inside of the flexible package to exit at a controlled flow rate such that the flexible package remains substantially in the inflated state while the flexible

package is conveyed and then the flexible package transitions to being substantially in a deflated state after the flexible package has been conveyed.

As will be described in greater detail below, the controlled rate of gas flow out of flexible packages allows the flexible packages to be conveyed while substantially in the inflated state while then being shipped substantially in the deflated state. In some examples, conveying the flexible packages while substantially in the inflated state increases the ability of the flexible packages to be conveyed (e.g., moved on conveyors, moved on rollers, and sorted in sortation systems) without being caught in any conveyance machinery or otherwise failing during conveyance. In some examples, shipping the flexible packages while substantially in the deflated state allows for decrease shipping volumes of the flexible packages resulting in lower dimensional weight and higher packaging density, which saves on shipping costs. In addition, the embodiments described herein are able to reduce labor required to ship the flexible packages by reducing the need for human intervention to convey and sort mailers and to reduce cost of fines by shipping companies by preventing sorting errors caused by manual sortation.

FIG. 1 depicts an embodiment of a system 10 that includes a packaging system 12. In the depicted embodiment, the packaging system 12 is a continuous flow wrap machine (e.g., a form-fill-seal wrapper). In other embodiments, the packaging system 12 is a non-continuous packaging system. In the depicted embodiment, the packaging system 12 includes a film dispenser 18, a transfer head 20 including an inverting head 22, an infeed conveyor 24, a longitudinal sealer 26, and an end sealer 28, as will be described in more detail herein. Examples of continuous flow wrap machines are described, for example, in U.S. Pat. No. 4,219,988, U.S. Patent Application No. 62/157,164, and PCT Application No. PCT/US2016/030630, the contents of which are incorporated herein by reference in their entirety, and are available from Sealed Air Corporation (Charlotte, N.C.) under the Shanklin FloWrap Series trademark.

The film dispenser 18 of the continuous flow wrap machine supplies a web of film 30 from roll 32. Systems for supplying webs of film are known in art and may include unwind mechanisms and other features. In some embodiments, the film 30 on the roll 32 is a center folded film. In other embodiments, the film 30 on roll 32 is a flat wound film. In some embodiments, the film 30 includes any sheet or film material suitable for packaging objects 36, in particular for flexible packages 34 for use as a mailer containing an object. Suitable materials include polymers, for example thermoplastic polymers (e.g., polyethylene), that are suitable for heat sealing. In some embodiments, the film 30 has a thickness of any of at least 2, 3, 5, 7, 10, and 15 mils; and/or at most any of 25, 20, 16, 12, 10, 8, 6 and 5 mils. In some embodiments, the film 30 is multilayered, and has an outer layer adapted for heat sealing the film to itself to form a seal.

The transfer head 20 of the packaging system 10 receives the web of film 30 from the film dispenser 18. The transfer head 20 is adapted to manage (e.g., form) the web of film 30 into a configuration for eventual sealing into a tube. In the depicted embodiment, the transfer head 20 is an inverting head 22 of continuous flow wrap that receives a center folded web of film 30 from the film dispenser 18 and redirects the web of film over the top and bottom inverting head arms 40, 42 to travel in a conveyance direction 38 by turning the web of film inside out. In this manner, the transfer head 20 is adapted to manage the web of film 30 to provide an interior space 44 bounded by the film 30.

In some embodiments, the transfer head **20** in the configuration of a forming box receives the lay flat web of film **30** from the film dispenser **18** and redirects the web of film over the forming head to travel in the conveyance direction **38** by turning the web of film inside out. In this manner, the transfer head **20** is adapted to manage the web of film **30** to provide an interior space **44** bounded by film **30**.

The infeed conveyor **24** of packaging system **12** is adapted to transport a series of objects **36** and sequentially deliver them in the conveyance direction **38**. In some embodiments, the infeed conveyor is adapted to convey a series of objects **36**. In the embodiment depicted in FIG. 1, the objects **36** have a similar size. In other embodiments, the objects have varied or differing sizes. Within the series of objects **36** in sequential order, a “preceding” object is upstream from a “following” object. The infeed conveyor **24** is configured to deliver in repeating fashion a preceding object upstream from a following object into the interior space **44** of the web of film **30**. In some embodiments, the objects **36** are delivered in spaced or gapped arrangement from each other.

An “object,” as used herein, may comprise a single item for packaging, or may comprise a grouping of several distinct items where the grouping is to be in a single package. Further, an object may include an accompanying informational item, such as a packing slip, tracking code, a manifest, an invoice, or printed sheet comprising machine-readable information (e.g., a bar code) for sensing by an object reader (e.g., a bar code scanner).

Downstream from the infeed conveyor **24** is an object conveyor **48**, which is adapted to support and transport the web of film **30** and the object **36** downstream together to the end sealer **28**. A discharge conveyor **50** transports the series of packages **34** from the end sealer **28**.

As each object **36** of the series of objects sequentially travels through the packaging system **12**, its position within the machine is tracked. This is accomplished by ways known in the art. For example, an infeed eye system (horizontal or vertical) determines the location of the front edge **52** of each object and the location of the rear edge **54** of each object as the object travels along the conveyor. This location information is communicated to a controller (i.e., a programmable logic controller or “PLC”). A system of encoders and counters, also in communication with the PLC, determines the amount of travel of the conveyor on which the object is positioned. In this manner, the position of the object **36** itself is determined and known by the PLC. The PLC is also in communication with the end sealer **28** to provide the object position information for a particular object to these unit operations.

In the depicted embodiment, the packaging system **12** includes longitudinal sealers **26** adapted to continuously seal sides of the film **30** together to form a tube **56** enveloping one of the objects **36**. In the depicted embodiment, the longitudinal sealers **26** are located at sides of the tube **56**, where each of the longitudinal sealers **26** forms a side seal between two edge portions of the film **30**. In other embodiments, a The longitudinal sealer **26** may be located beneath the tube **56**, where the sealer may form, for example, a center fin seal between two edge portions of the web of film **30**. As two edge portion of film **30** are brought together at the longitudinal sealer **26** to form the tube **56**, they are sealed together, for example, by a combination of heat and pressure, to form a continuous fin or a side seal. Appropriate longitudinal sealers are known in the art, and include, for example, heat sealers.

The packaging system **12** includes end sealer **28**, which is adapted to provide or perform in repeating fashion, while the tube **56** is traveling: (i) a trailing edge seal **58** that is transverse to tube **56** and upstream from a preceding object to create flexible package **34** and (ii) a leading edge seal **60** transverse to the tube **56** and downstream from a following object. Further, the end sealer **28** is adapted to sever the flexible package **34** from the tube **56** by cutting between the trailing edge seal **58** and the leading edge seal **60**. Generally, the end sealer **28** uses temperature and pressure to make two seals (trailing edge seal **58** and leading edge seal **60**) and cuts between them, thus creating the final, trailing seal of one finished, preceding package and the first, leading edge seal of the following package. Advantageously, the end sealer unit may be adapted to simultaneously sever the flexible package **34** from the tube **56** while providing the trailing edge seal **58** and leading edge seal **60**.

Useful end sealer units are known in the art. These include, for example, rotary type of end sealer units, having matched heated bars mounted on rotating shafts. As the film tube passes through the rotary type, the rotation is timed so it coincides with the gap between objects. A double seal is produced and the gap between the two seals is cut by an integral blade to separate individual packs. Another type of end seal unit is the box motion type, having a motion that describes a “box” shape so that its horizontal movement increases the contact time between the seal bars and the film. Still another type of end sealer unit is the continuous type, which includes a sealing bar that moves down with the tube while sealing.

While the system **10** depicted in FIG. 1 is capable of packaging objects **36** in flexible packages **34** that are suitable for shipping, the flexible packages **34** are susceptible to failure during conveyance. Depicted in FIGS. 2A to 2C are examples of possible failures of the flexible packages **34** during conveyance.

In FIG. 2A, a side view of a roller system **62** is depicted. A flexible package **34** with an object **36** inside is conveyed by the roller system **62** in the conveyance direction **38** over a number of rollers **64**. As shown in FIG. 2A, a loose portion of the flexible package **34** is able to slip between two of the rollers **64**. This loose portion of the flexible package **34** may jam the flexible package **34** in the rollers **64**, preventing the flexible package **34**, and possibly other flexible packages **34**, from moving further in the conveyance direction **38** until a person manually clears the jam.

In FIG. 2B, a side view of a conveyor belt system **66** is depicted. A flexible package **34** with an object **36** inside is conveyed by the conveyor belt system **66** in the conveyance direction **38** over two conveyor belts **68**. As shown in FIG. 2B, a loose portion of the flexible package **34** is able to slip between the two conveyor belts **68**. This loose portion of the flexible package **34** may jam the flexible package **34** in the conveyor belts **68**, preventing the flexible package **34**, and possibly other flexible packages **34**, from moving further in the conveyance direction **38** until a person manually clears the jam.

In FIG. 2C, a top view of a sortation system **70** is depicted. The sortation system **70** includes a gate **72** that directs flexible packages **34** from an upstream chute into one of two downstream chutes in the conveyance direction **38**. As shown in FIG. 2C, a loose portion of the flexible package **34** is caught in the gate **72**. This loose portion of the flexible package **34** may jam the flexible package **34** in the chute, preventing the flexible package **34** and other upstream flexible packages, from moving further in the conveyance direction **38** until a person manually clears the jam.

Depicted in FIG. 3 is an embodiment of a system 10' that is a variation of the system 10 depicted in FIG. 1. The system 10' is different from the system 10 in a number of ways. In one example, the film dispenser 18 includes a web of film 30' that has vent holes 46. Thus, the flexible packages 34' created by the system 10' also have vent holes 46. In some embodiments, at least one characteristic of the vent holes 46—such as a size of the vent holes 46, a shape of the vent holes 46, a number of the vent holes 46, a location of the vent holes 46, or a pattern of the vent holes 46—is selected to control a flow rate of gas exiting the flexible packages 34'.

In another example, the system 10' includes a source of pressurized gas 80. In the depicted embodiment, the source of pressurized gas 80 is a container (e.g., a cylinder) of pressurized gas. In other embodiments, the source of pressurized gas 80 is a gas compressor or any other machine or container configured to provide pressurized gas. The source of pressurized gas 80 is in fluid communication with a nozzle 82 configured to insert gas in the flexible packages 34'. In the depicted embodiment, the nozzle 82 is configured to direct gas through the interior space 44 and the tube 56 so that the flexible packages 34' are in an inflated state when the end sealer 28 seals the trailing edge of the flexible packages 34'. In some embodiments, the flexible packages 34' are configured to reaming substantially in the inflated state while they are conveyed on discharge conveyor 50 and any subsequent conveyors. In the depicted embodiment, the source of pressurized gas 80 is coupled to the nozzle via piping 84. The piping 84 may include rigid piping (e.g., copper piping) or flexible piping (e.g., rubber tubing). In the depicted embodiment, a valve 86 is located between the source of pressurized gas 80 and the nozzle 82. In some examples, the valve 86 is controlled by a computing device or other manual, semi-automatic or automatic means so that a particular amount of gas is inserted into the flexible packages 34' to place the flexible packages 34' in the inflated state.

FIGS. 4A, 4B, and 4C depict, respectively, top, side, and end cross-sectional views of a flexible package 100 in an inflated state. The flexible package 100 encloses an object 102. While the object 102 depicted in FIGS. 4A to 4C has a rectangular prism shape, the flexible package 100 may enclose objects of any shape. The flexible package 100 is made from a first film 104 and a second film 106. The first film 104 and the second film 106 are sealed to each other along side seals 108 and along end seals 110. Both the first film 104 and the second film 106 include vent holes 112 that permit gas to exit the flexible package 100. In some embodiments, the flow rate of gas out of the flexible package 100 is controlled by selecting one or more of a size of the vent holes 112, a shape of the vent holes 112, a number of the vent holes 112, a location of the vent holes 112, or a pattern of the vent holes 112.

The flexible package 100 may be in the inflated state, as shown in FIGS. 4A to 4C, when the edges are sealed. However, because the vent holes 112 permit gas to exit the flexible package 100, the flexible package 100 does not remain in the inflated state. In some embodiments, one or more characteristics of the vent holes 112 are selected so that the flexible package 100 remains in the inflated state or substantially in the inflated state while the flexible package is conveyed within the shipping facility. In some embodiments, the pressure inside of the flexible package 100 is at least 1% higher than the pressure outside of the flexible package 100 when the flexible package is in the inflated state and when the flexible package is substantially in the inflated state. For example, the pressure inside of the flexible pack-

age 100 can be in a range from 1 to 10% higher than the pressure outside of the flexible package 100 when the flexible package is in the inflated state and when the flexible package is substantially in the inflated state. In some embodiments, the pressure inside of the flexible package 100 is at least 2.5 kPa above atmospheric pressure when the flexible package 100 is in the inflated state and when the flexible package is substantially in the inflated state. In some embodiments, when the flexible package 100 is in the inflated state and when the flexible package is substantially in the inflated state, a top portion of the flexible package 100 does not contact a top portion of the object 102, as can be seen in FIGS. 4A to 4C.

After the flexible package 100 has been conveyed, the vent holes 112 continues to permit gas to exit the flexible package 100 until the flexible package 100 transitions to being substantially in a deflated state. Depicted in FIGS. 5A, 5B, and 5C are, respectively, top, side, and end cross-sectional views of the flexible package 100 substantially in a deflated state. In some embodiments, the pressure inside of the flexible package 100 is in a range between the pressure outside of the flexible package 100 and a pressure that is 0.2% higher than the pressure outside of the flexible package 100 when the flexible package 100 is substantially in the deflated state. In some embodiments, the pressure inside of the flexible package 100 is in a range between the pressure outside of the flexible package 100 and a pressure that is 0.5 kPa higher than the pressure outside of the flexible package 100 when the flexible package 100 is substantially in the deflated state. In some embodiments, when the flexible package 100 is substantially in the deflated state, the top portion of the flexible package 100 is in contact with the top portion of the object 102.

After the flexible package 100 has transitioned to being substantially in the deflated state, the flexible package 100 may continue to deflate as gas continues to exit the flexible package 100 via the vent holes 112. In some embodiments, the object 102 is enclosed in the flexible package 100 and conveyed in a shipping facility (e.g., a warehouse). After the flexible package 100 is conveyed while substantially in the inflated state, the flexible package 100 transitions to being substantially in the deflated state while still in the shipping facility. At that point, the flexible package 100 is ready to be shipped with lower dimensional weight and higher packaging density, which saves on shipping costs.

FIG. 6 depicts an embodiment of a system 210 that includes a packaging system 212. In the depicted embodiment, the packaging system 212 is a continuous flow wrap machine (e.g., a form-fill-seal wrapper) or a non-continuous packaging system. A web of film 230 is supplied to form flexible packages 234 around objects 236. In some embodiments, the film 230 includes any sheet or film material suitable for packaging objects 236, in particular for flexible packages 234 for use as a mailer. Suitable materials include polymers, for example thermoplastic polymers (e.g., polyethylene), that are suitable for heat sealing. In some embodiments, the film 230 is multilayered, and has an outer layer adapted for heat sealing the film to itself to form a seal.

An infeed conveyor 224 of the packaging system 212 is adapted to transport a series of the objects 236 and sequentially deliver them in a conveyance direction 238. In some embodiments, the infeed conveyor 224 is adapted to convey a series of the objects 236. In the embodiment depicted in FIG. 6, the objects 236 are folded shirts that have a similar size. In other embodiments, the objects have varied or differing sizes. Within the series of objects 236 in sequential order, a “preceding” object is upstream from a “following”

object. The infeed conveyor **224** is configured to deliver in repeating fashion a preceding object upstream from a following object into an interior space **244** of the web of film **230**.

Downstream from the infeed conveyor **224** is an object conveyor **248**, which is adapted to support and transport the web of film **230** and the object **236** downstream together to the end sealer **228**. A conveying system **250** transports the series of the flexible packages **234** from the end sealer **228** to a cart **270**. In the depicted embodiment, the conveying system **250** includes a conveyor belt **252** and a set of rollers **254**. In other embodiments, the conveying system **250** after the end sealer **228** may include any number of conveyor belts, rollers, chutes, sortation systems, other forms of conveyance, or any combination thereof.

In the depicted embodiment, the packaging system **212** includes longitudinal sealers **226** adapted to continuously seal sides of the film **230** together to form a tube **256** enveloping one of the objects **236**. In the depicted embodiment, the longitudinal sealers **226** are located at sides of the tube **256**, where each of the longitudinal sealers **226** forms a side seal between two edge portions of the film **230**. As two edge portions of film **230** are brought together at the longitudinal sealer **226** to form the tube **256**, they are sealed together, for example, by a combination of heat and pressure, to form a continuous fin or a side seal. Appropriate longitudinal sealers are known in the art, and include, for example, heat sealers.

The packaging system **212** includes an end sealer **228**, which is adapted to provide or perform in repeating fashion, while the tube **256** is traveling: (i) a trailing edge seal that is transverse to tube **256** and upstream from a preceding object to create the flexible packages **234** and (ii) a leading edge seal transverse to the tube **256** and downstream from a following object. Further, the end sealer **228** is adapted to sever the flexible packages **234** from the tube **256** by cutting between the trailing edge seal and the leading edge seal. Generally, the end sealer **228** uses temperature and pressure to make two seals (trailing edge seal and leading edge seal) and cuts between them, thus creating the final, trailing seal of one finished, preceding package and the first, leading edge seal of the following package. Advantageously, the end sealer unit may be adapted to simultaneously sever the flexible packages **234** from the tube **256** while providing the trailing and leading edge seals.

The packaging system **212** includes an inflation system **280**. The inflation system **280** includes a nozzle **282** configured to insert gas into the flexible packages **234**. In the depicted embodiment, the nozzle **282** is configured to direct gas through the interior space **244** and the tube **256** so that the flexible packages **234** are in an inflated state when the end sealer **228** seals the trailing edge of the flexible packages **234**. The inflation system **280** also includes a source of pressurized gas (not shown) that is in fluid communication with the nozzle **282** via piping **284**. In some embodiments, the source of pressurized gas is a container (e.g., a cylinder) of pressurized gas, a gas compressor, or any other machine or container configured to provide pressurized gas.

Conveying the flexible packages **234** while the flexible packages are substantially in an inflated state decreases the possibility of the flexible packages **234** failing during conveyance by the conveying system **250**. In one particular example shown in FIG. 6, one of the flexible packages **234** that is substantially in the inflated state is able to be transferred from the conveyor belt **252** to the set of rollers **254** without being caught or jammed during the transfer. The flexible packages **234** that are in the inflated state or sub-

stantially in the inflated state form “pillows” that are more rigid than flexible packages in the deflated state. This increased rigidity reduces the possibility of the flexible packages **234** failing during conveyance.

After conveyance, the gas in the flexible packages **234** continues to exit until the flexible packages are substantially in a deflated state. One example of this continued deflation is depicted in FIG. 7. On the left side of FIG. 7, the flexible package **234** is located in the cart **270** after having been conveyed on the conveying system **250**. In this state, the flexible package **234** is substantially in the inflated state. As shown by the arrows, gas exits the flexible package **234**, such as by exiting through vent holes in the flexible package **234**. The gas continues to exit the flexible package **234** until the flexible package **234** is substantially in the deflated state, as shown on the right side of FIG. 7. While the flexible package **234** is located in the cart **270** during deflation in the embodiment shown in FIG. 7, the flexible package **234** may be located in any other location during deflation. In some examples, the flexible package **234** may be located on a shelf, in a bin, on the end of the conveyance system, or in any other location during deflation.

As noted above, a flow rate of gas out of flexible packages may be controlled by one or more characteristics of vent holes in the flexible package. In some embodiments, the one or more characteristics include one or more of a size of the vent holes, a shape of the vent holes, a number of the vent holes, a location of the vent holes, or a pattern of the vent holes. Depicted in FIGS. 8A to 8D are embodiments of films having vent holes with different characteristics.

In FIG. 8A, a film **300** includes vent holes **302** that are circular in shape. The vent holes **302** are arranged as rows **304** of three vent holes **302** periodically spaced along the length of the film **300**. The rows **304** of the vent holes **302** are located near the sides of the film **300**. In FIG. 8B, a film **310** includes vent holes **312** that are x-shaped. The shape of the vent holes **312** may provide for a different flow rate of gas through the vent holes **312** than flows through the circular vent holes **302**. The vent holes **312** are arranged as a single row **314** of five vent holes **312** periodically spaced along the length of the film **310**. Placing the row **314** of vent holes **312** near the center of the film **310** may provide a different flow rate of gas through the vent holes **312** than flows through the circular vent holes **302** that are located near the sides of the film **300**.

In FIG. 8C, a film **320** includes vent holes **322** that are circular in shape. Each of the vent holes **322** is smaller in diameter than the vent holes **302** depicted in FIG. 8A, which may provide a reduced flow rate through each of the vent holes **322** than flows through each of the vent holes **302**. The vent holes **322** are also arranged in a pattern **324** located near the center of the film **320**. The pattern **324** itself may be selected based on a desired flow rate of gas through the vent holes **322** or the pattern **324** may be selected based on a desired aesthetic look of the film **320**.

In FIG. 8D, a film **330** includes vent holes **332** that are circular in shape. Each of the vent holes **332** is larger in diameter than the vent holes **322** depicted in FIG. 8C, which may provide an increased flow rate through each of the vent holes **332** than flows through each of the vent holes **322**. The vent holes **332** are also arranged in a pattern **334** located near the center of the film **330**. The pattern **334** is in the shape of a logo or other picture, which may be selected based on a desired aesthetic look or selected to provide an advertising feature, such as in the case where the pattern **334** is a logo or trademark associated with a company.

While the sizes, shapes, number, patterns, and locations of vent holes depicted in FIGS. 8A to 8D show specific embodiments of vent hole characteristics, it should be noted that vent holes can be in any other size, shape, number, pattern, and location. Because vent hole characteristics affect flow rates of gas through the vent holes, the characteristics of vent holes may be selected such that a flexible package that includes the vent holes remains substantially in an inflated state during conveyance in a shipping facility before transitioning to substantially to a deflated state.

In some embodiments, one or more vent hole characteristics (e.g., size, shape, number, pattern, and/or location) in film may be selected to provide functionality to a flexible package formed from the film. In one example, one or more vent hole characteristics are selected such that vent holes are arranged in the film to aid in the propagated, controlled opening of the flexible package (e.g., by a recipient of the flexible package). In another example, one or more vent hole characteristics are selected such that vent holes are arranged in the film to prevent damage to the flexible package. In another example, one or more vent hole characteristics are selected such that vent holes are arranged in the film to and allow the flexible package to be reused (e.g., reused by a recipient of the flexible package). In other examples, one or more vent hole characteristics are selected such that vent holes are arranged in the film to provide the flexible package with any other type of functionality.

For purposes of this disclosure, terminology such as “upper,” “lower,” “vertical,” “horizontal,” “inwardly,” “outwardly,” “inner,” “outer,” “front,” “rear,” and the like, should be construed as descriptive and not limiting the scope of the claimed subject matter. Further, the use of “including,” “comprising,” or “having” and variations thereof herein is meant to encompass the items listed thereafter and equivalents thereof as well as additional items. Unless limited otherwise, the terms “connected,” “coupled,” and “mounted” and variations thereof herein are used broadly and encompass direct and indirect connections, couplings, and mountings. Unless stated otherwise, the terms “substantially,” “approximately,” and the like are used to mean within 5% of a target value.

The principles, representative embodiments, and modes of operation of the present disclosure have been described in the foregoing description. However, aspects of the present disclosure which are intended to be protected are not to be construed as limited to the particular embodiments disclosed. Further, the embodiments described herein are to be regarded as illustrative rather than restrictive. It will be appreciated that variations and changes may be made by others, and equivalents employed, without departing from the spirit of the present disclosure. Accordingly, it is expressly intended that all such variations, changes, and equivalents fall within the spirit and scope of the present disclosure, as claimed.

What is claimed is:

1. A system comprising:
 - a packaging system configured to place an object in a flexible package;
 - an inflation system configured to insert a gas into the flexible package from a source of pressurized gas, wherein the packaging system is further configured to seal an edge of the flexible package in an inflated state with the object and the inserted gas inside the flexible package; and
 - a conveying system configured to convey the flexible package while the flexible package is substantially in the inflated state;
 wherein the flexible package is configured to permit gas to escape the flexible package at a controlled flow rate such that the flexible package remains substantially in the inflated state while being conveyed by the conveying system and such that the flexible package transitions to being substantially in a deflated state after being conveyed by the conveying system; and
 - wherein the flexible package includes one or more vent holes configured to permit the gas to escape the flexible package.
2. The system of claim 1, wherein the system is located in a shipping facility, and wherein the flexible package is configured to be shipped from the shipping facility when the flexible package is substantially in the deflated state.
3. The system of claim 1, further comprising:
 - a film dispenser configured to supply film to the packaging system, wherein the packaging system is configured to form the flexible package from the film.
4. The system of claim 3, wherein the film includes the one or more vent holes.
5. The system of claim 4, wherein at least one characteristic of the one or more vent holes is selected to control the controlled flow rate of the gas out of the flexible package.
6. The system of claim 5, wherein the at least one characteristic includes one or more of a size of the one or more vent holes, a shape of the one or more vent holes, a number of the one or more vent holes, a location of the one or more vent holes, or a pattern of the one or more vent holes.
7. The system of claim 5, wherein the at least one characteristic of the one or more vent holes is selected to provide the flexible package with a type of functionality.
8. The system of claim 7, wherein the type of functionality includes at least one of aid in opening of the flexible package, prevention of damage to the flexible package, or improved ability to reuse the flexible package.
9. The system of claim 4, wherein the conveying system includes one or more of a conveyor belt or a plurality of rollers.
10. The system of claim 1, wherein the inflation system includes the source of pressurized gas, and wherein the source of pressurized gas includes one or more of a container of pressurized gas or a gas compressor.

* * * * *