



US010389011B2

(12) **United States Patent**
Zhao et al.

(10) **Patent No.:** **US 10,389,011 B2**

(45) **Date of Patent:** **Aug. 20, 2019**

(54) **ANTENNA DEVICE FOR MOBILE TERMINAL AND MOBILE TERMINAL**

USPC 343/702
See application file for complete search history.

(71) Applicant: **GUANGDONG OPPO MOBILE TELECOMMUNICATIONS CORP., LTD.**, Dongguan (CN)

(56) **References Cited**

U.S. PATENT DOCUMENTS

(72) Inventors: **Ning Zhao**, Dongguan (CN); **Haijun Tang**, Dongguan (CN); **Guolin Liu**, Dongguan (CN); **Shasha Hu**, Dongguan (CN)

8,378,909 B2* 2/2013 Sato H01Q 1/243
343/702
9,871,286 B2* 1/2018 Kang H01Q 5/35
2006/0139211 A1 6/2006 Vance et al.
2011/0309993 A1 12/2011 He et al.
2014/0256800 A1* 9/2014 Simpson A61K 48/0058
514/44 R

(73) Assignee: **GUANGDONG OPPO MOBILE TELECOMMUNICATIONS CORP. LTD.**, Dongguan, Guangdong (CN)

(Continued)

(*) Notice: Subject to any disclaimer, the term of this patent is extended or adjusted under 35 U.S.C. 154(b) by 0 days.

FOREIGN PATENT DOCUMENTS

CN 105337036 A 2/2016
CN 105789827 7/2016

(Continued)

(21) Appl. No.: **15/669,550**

(22) Filed: **Aug. 4, 2017**

(65) **Prior Publication Data**

US 2018/0183136 A1 Jun. 28, 2018

(30) **Foreign Application Priority Data**

Dec. 28, 2016 (CN) 2016 1 1237642
Dec. 28, 2016 (CN) 2016 2 1462704 U

Primary Examiner — Peguy Jean Pierre

(74) *Attorney, Agent, or Firm* — Hodgson Russ LLP

(51) **Int. Cl.**

H01Q 1/24 (2006.01)
H01Q 5/335 (2015.01)
H01Q 13/10 (2006.01)
H01Q 5/314 (2015.01)

(57) **ABSTRACT**

An antenna device includes a slot, a connecting assembly, a first capacitor and a match circuit. The slot is defined in a shell of the mobile terminal. The slot separates the shell into a first part and a second part, and the first part couples with a mainboard via a feeding point to form a slot antenna. The connecting assembly connects the first part with the second part. The first capacitor couples the first part with the feeding point. The match circuit couples the first part with the feeding point.

(52) **U.S. Cl.**

CPC **H01Q 1/243** (2013.01); **H01Q 5/314** (2015.01); **H01Q 5/335** (2015.01); **H01Q 13/10** (2013.01)

(58) **Field of Classification Search**

CPC H01Q 1/243; H01Q 13/18; H01Q 5/35

18 Claims, 4 Drawing Sheets

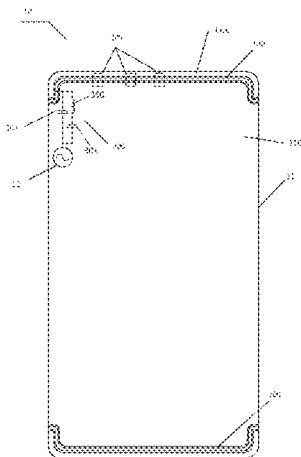

(56)

References Cited

U.S. PATENT DOCUMENTS

2015/0057054 A1 2/2015 Su et al.
2015/0070219 A1 3/2015 Dinh et al.
2016/0134010 A1 5/2016 Yan
2016/0218422 A1 7/2016 Choi et al.
2016/0351997 A1 12/2016 Wu et al.
2018/0069306 A1* 3/2018 Xue H01Q 1/44

FOREIGN PATENT DOCUMENTS

CN 106025509 A 10/2016
CN 106229617 12/2016
CN 106785432 A 5/2017
CN 206332179 U 7/2017
WO 2013107921 A1 7/2013

OTHER PUBLICATIONS

EPO, Office Action for EP Application No. 17182742, dated Jan. 12, 2018.

EPO, Office Action for EP Application No. 17182742, dated Dec. 20, 2018.

* cited by examiner

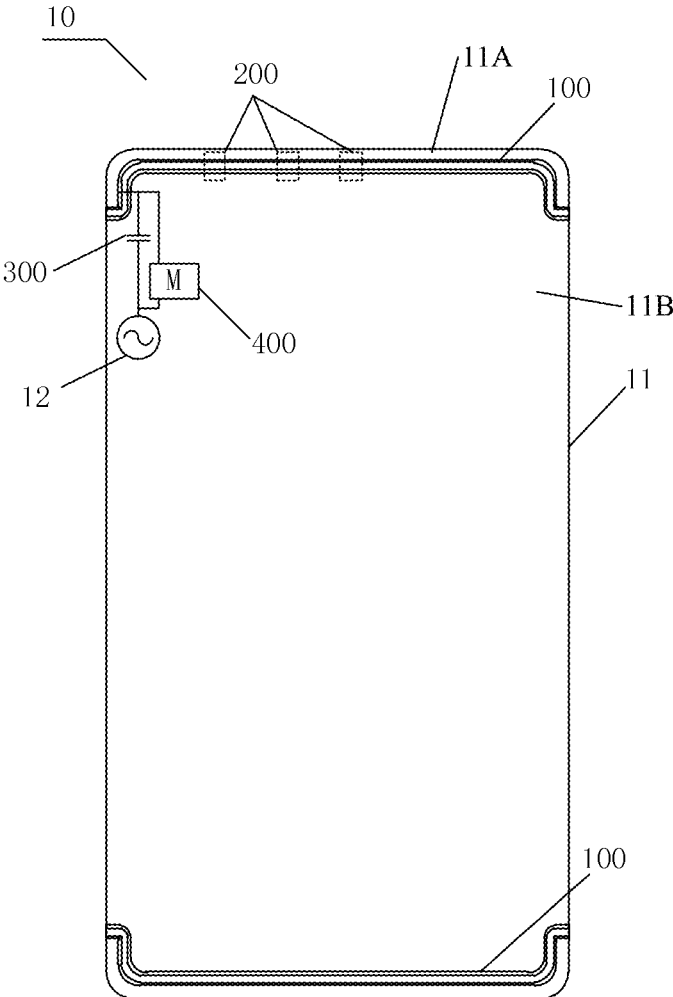

Fig. 1

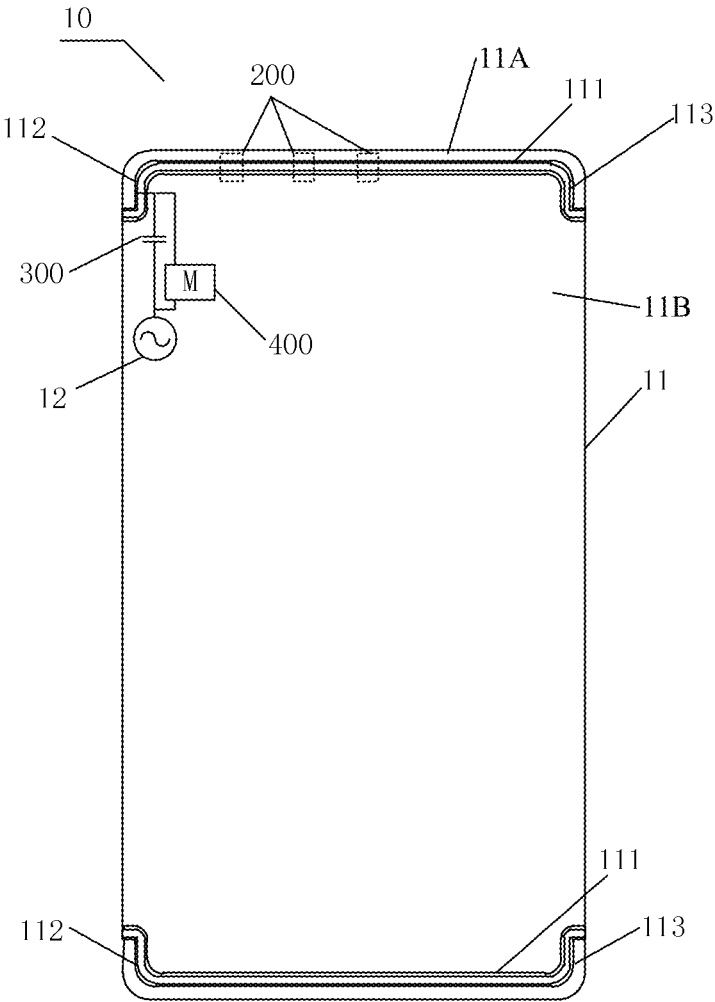

Fig. 2

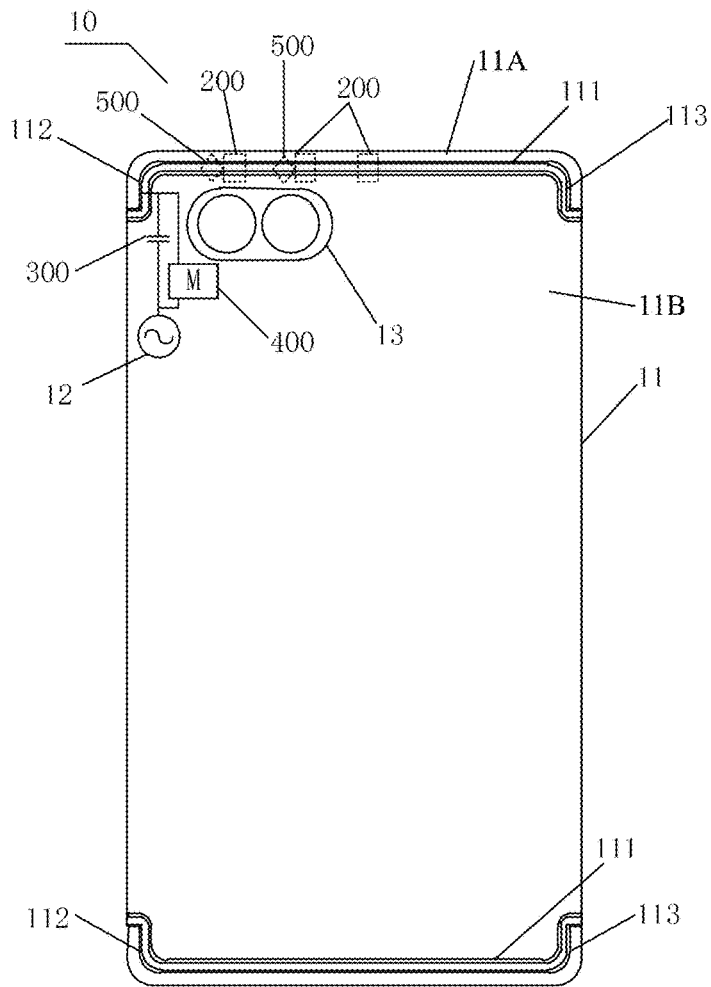

Fig. 3

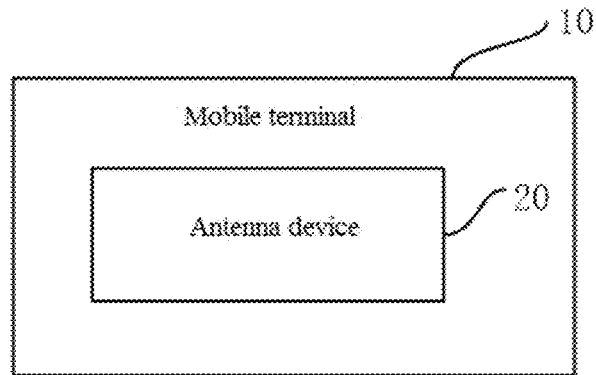

Fig. 4

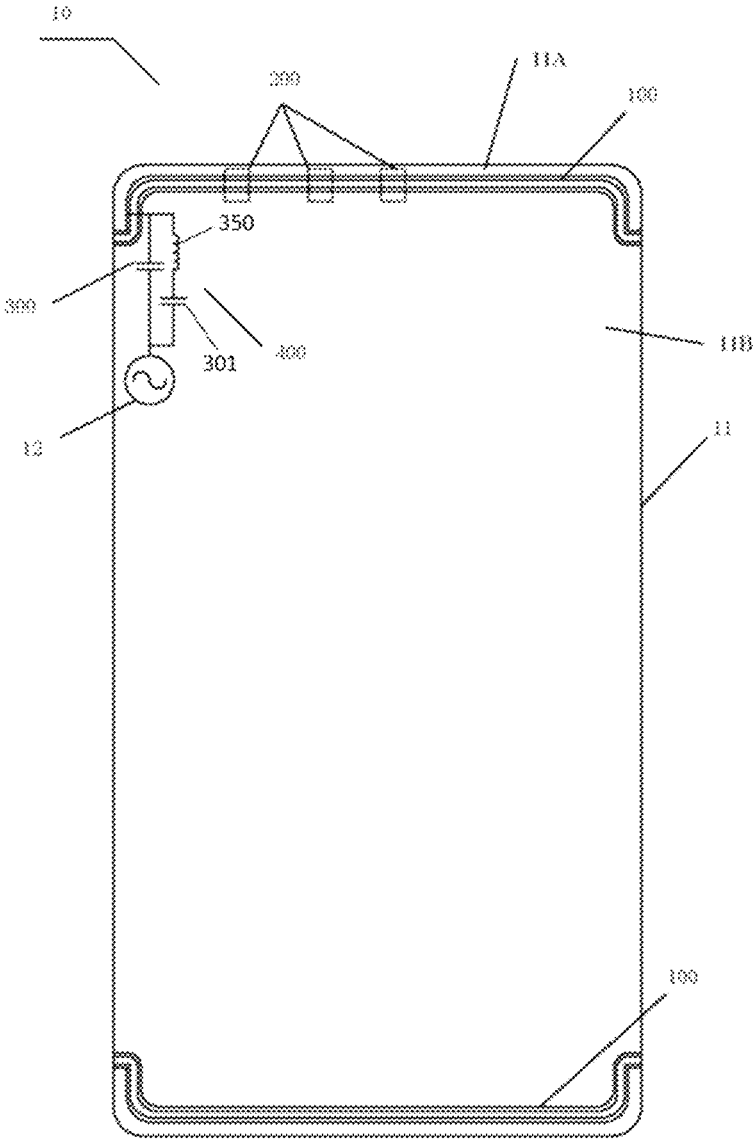

Fig. 5

1

**ANTENNA DEVICE FOR MOBILE
TERMINAL AND MOBILE TERMINAL****CROSS-REFERENCE TO RELATED
APPLICATIONS**

This application claims priority to and benefits of Chinese Patent Application Serial No. 201611237642.9 and No. 201621462704.1, both filed with the State Intellectual Property Office of P. R. China on Dec. 28, 2016, the entire contents of which are incorporated herein by reference.

FIELD

The present disclosure relates to a field of mobile terminals, and more particularly to an antenna device for a mobile terminal and a mobile terminal having the same.

BACKGROUND

With developments of mobile communication, there are various types and materials developed for mobile terminals, especially for mobile phones. Recently, it has become increasingly popular to design the rear cover as metal shells because of the favorable appearance and good touching feel of the metal shell and the better wear-resistance compared with plastic shells such as polycarbonate (PC) or acrylonitrile butadiene styrene copolymer (ABS) shells.

At present, the main types of antenna for mobile terminals, particularly for mobile phones, are a planar inverted-F antenna (PIFA), an inverted-F antenna (IFA), a unipolar antenna and a loop antenna. However, these antennas could not efficiently send or receive electromagnetic signals when applied on a mobile terminal having a metal shell.

SUMMARY

Embodiments of the present disclosure seek to solve at least one of the problems existing in the related art to at least some extent.

Accordingly, a first objective of the present disclosure is to provide an antenna device for a mobile terminal.

A second objective of the present disclosure is to provide a mobile terminal.

In a first aspect of the present disclosure, an antenna device for a mobile terminal is provided. The antenna device includes a slot, a connecting assembly, a first capacitor and a match circuit. The slot is defined in a shell of the mobile terminal. The slot separates the shell into a first part and a second part, and the first part is configured to couple with a mainboard via a feeding point to form a slot antenna. The connecting assembly connects the first part with the second part. The first capacitor couples the first part with the feeding point. The match circuit couples the first part with the feeding point.

In a second aspect of the present disclosure, a mobile terminal is provided, including a shell, a mainboard, and an antenna device. The antenna device includes a slot, a connecting assembly, a first capacitor and a match circuit. The slot is provided in the shell of the mobile terminal. The slot divides the shell into a first part and a second part, and the first part is coupled to the mainboard via a feeding point to form a slot antenna. The connecting assembly connects the first part to the second part. The first capacitor is connected between the first part and the feeding point. The match circuit is connected between the first part and the feeding point.

2

Additional aspects and advantages of embodiments of the present disclosure will be given in part in the following descriptions, become apparent in part from the following descriptions, or be learned from the practice of the embodiments of the present disclosure.

BRIEF DESCRIPTION OF THE DRAWINGS

These and other aspects and advantages of embodiments of the present disclosure will become apparent and more readily appreciated from the following descriptions made with reference to the drawings as described below.

FIG. 1 is a schematic view of an antenna device for a mobile terminal according to an embodiment of the present disclosure.

FIG. 2 is a schematic view of an antenna device for a mobile terminal according to another embodiment of the present disclosure.

FIG. 3 is a schematic view of an antenna device for a mobile terminal according to a further embodiment of the present disclosure.

FIG. 4 is a block diagram of a mobile terminal according to an embodiment of the present disclosure.

FIG. 5 is a schematic view of an antenna device for a mobile terminal according to a further embodiment of the present disclosure.

DETAILED DESCRIPTION

Reference will be made in detail to embodiments of the present disclosure. The embodiments described herein with reference to drawings are explanatory, illustrative, and used to generally understand the present disclosure. The embodiments shall not be construed to limit the present disclosure. The same or similar elements and the elements having same or similar functions are denoted by like reference numerals throughout the descriptions.

In an embodiment of present disclosure, the antenna device includes a slot, a connecting assembly, a first capacitor and a match circuit. The slot is defined in a shell of the mobile terminal. The slot separates the shell into a first part and a second part, and the first part is configured to couple with a mainboard via a feeding point to form a slot antenna. The connecting assembly connects the first part with the second part. The first capacitor couples the first part with the feeding point. The match circuit couples the first part with the feeding point.

In an embodiment of present disclosure, the slot antenna covers a frequency in a range of at least one of 2.4 to 2.48 GHz and 5.1 to 5.85 GHz to form a WIFI communication antenna and the slot antenna is adjusted to cover the frequency in a range of 1.5 to 1.6 GHz by the match circuit to form a GPS antenna.

In an embodiment of present disclosure, the slot has a C-shape or a U-shape.

In an embodiment of present disclosure, the slot includes a straight line section, a first bent section, a second bent section. The straight line section includes a first end and a second end opposite to the first end. The first bent section is connected with the first end of the straight line section. The second bent section is connected with the second end of the straight line section. In other word, the first bent section extends from the first end of the straight line section, and the second bent section extends from the second end of the straight line section.

In an embodiment of present disclosure, the match circuit includes a second capacitor and a first inductor connected with the second capacitor.

In an embodiment of present disclosure, the connecting assembly is a metal connecting sheet.

In an embodiment of present disclosure, the connecting assembly is connected with the first part and the second part by means of laser welding.

In an embodiment of present disclosure, the number of the connecting assemblies is 1 to 4.

In an embodiment of present disclosure, the slot is filled with an insulator.

In an embodiment of present disclosure, the insulator is a plastic material.

In an embodiment of present disclosure, a mobile terminal is provided, including a shell, a mainboard, and an antenna device. The antenna device includes a slot, a connecting assembly, a first capacitor and a match circuit. The slot is provided in the shell of the mobile terminal. The slot divides the shell into a first part and a second part, and the first part is coupled to the mainboard via a feeding point to form a slot antenna. The connecting assembly connects the first part to the second part. The first capacitor is connected between the first part and the feeding point. The match circuit is connected between the first part and the feeding point.

In an embodiment of present disclosure, the mobile terminal further includes a camera assembly. The feeding point is disposed between the camera assembly and the first bent section.

In an embodiment of present disclosure, the antenna device further includes a spring assembly. The camera assembly is connected with the connecting assembly by the spring assembly.

Reference will be made to the drawings to describe an antenna device for a mobile terminal and the mobile terminal with the same.

FIG. 1 is a schematic view of an antenna device for a mobile terminal according to an embodiment of the present disclosure. The antenna device according to the embodiments of the present disclosure may be arranged in a mobile terminal. The mobile terminal may be a mobile phone, a tablet computer or the like. In the illustrated embodiment of the present disclosure, the mobile terminal is a mobile phone.

As shown in FIG. 1, the antenna device for the mobile terminal may include a slot **100**, a connecting assembly **200**, a first capacitor **300** and a match circuit **400**. As shown in FIG. 1, the slot **100** is defined in a shell **11** of the mobile terminal **10**, separates the shell **11** into a first part **11A** and a second part **11B**, and the first part **11A** couples with a mainboard of the mobile terminal **10** by a feeding point **12** to form a slot antenna. In other words, the slot antenna may be functioned by the slot, the feeding point and (electrical) connections between the first part **11A** and the feeding point. The connecting assembly **200** may couples to the first part **11A** with the second part **11B** to electrically conductively connect the first part **11A** and the second part **11B**. The first capacitor **300** is coupled between the first part **11A** and the feeding point **12**. The match circuit **400** is coupled between the first part **11A** and the feeding point **12**.

It may be appreciated that in an embodiment of the present disclosure the number of the slots **100** may be two, for improving the radiation efficiency of the antenna device and the mobile terminal. For example, as shown in FIG. 1, one slot **100** may be defined in each of two end parts of the shell **11** of the mobile terminal **10**. For example, as shown in FIG. 1, there may be two slots **100**. It may be appreciated

that the number of the slots **100** is dependent on actual requirements. No specific restrictions are made here. Furthermore, the slot **100** may be filled with an insulator such as plastics to keep the integrity of all parts of the shell **11**.

As shown in FIG. 1, the shell **11** is divided in two parts by the slot **100** on the shell **11**, i.e. the first part **11A** and the second part **11B**. The first part **11A** and the second part **11B** may be electrically conductively connected by the connecting assembly **200** to form a closed circuit.

In embodiments of the present disclosure, the shell **11** of the mobile terminal **10** may be a whole-metal shell, i.e. a shell made of only a metal. Therefore, as an example, the connecting assembly **200** may be a metal connecting sheet. The connecting assembly **200** may be connected with the first part **11A** and the second part **11B** by means of laser welding. In other words, the connecting assembly **200** may be connected with the first part **11A** and the second part **11B** by means of laser welding to realize electrical connections.

It may be appreciated that the number and the position of the connecting assemblies **200** may be varied depending on actual requirements. It needs to be illustrated that, in one embodiment of the present disclosure, the number of the connecting assemblies **200** may be 1 to 4. For example, as shown in FIG. 1, there are three connecting assemblies **200** and they are disposed at different positions. Each of the connecting assemblies **200** is connected with the first part **11A** and the second part **11B** by means of laser welding.

In an embodiment of the present disclosure, the feeding point **12** may be disposed between the first part **11A** and the mainboard. The feeding point **12** may be a feed source of GPS/WIFI. The feed source of GPS/WIFI thus feeds the first part **11A** through the first capacitor **300** to form the slot antenna. In an embodiment of the present disclosure, the slot antenna covers a frequency in a range of 2.4-2.48 GHz/5.1-5.85 GHz, i.e. at least one of 2.4 to 2.48 GHz and 5.1 to 5.85 GHz to form a WIFI communication antenna and the match circuit **400** may be configured to adjust the slot antenna to cover the frequency in a range of 1.5 to 1.6 GHz to form a GPS antenna.

Specifically, the feeding point **12** may be a feed source of GPS/WIFI which feeds the first part **11A** through the first capacitor **300** to form the slot antenna. In an embodiment of the present disclosure, the capacitance value of the first capacitor **300** may be in a range of 0.5 pF to 2 pF. Thus, the slot antenna may cover a frequency in a range of 2.4-2.48 GHz/5.1-5.85 GHz, i.e. at least one of 2.4 to 2.48 GHz and 5.1 to 5.85 GHz to form a WIFI communication antenna and the match circuit **400** may be configured to adjust the slot antenna to cover the frequency in a range of 1.5 to 1.6 GHz to form a GPS antenna. Therefore, a three-in-one antenna can be realized in a limited space.

As an example, FIG. 5 shows that the match circuit **400** may include a second capacitor **301** and a first inductor **350** connected in series. In other words, the match circuit **400** may be a series resonator consisting of one second capacitor and one first inductor. It may be appreciated that the specific values of the second capacitor **301** and the first inductor **350** in the match circuit **400** may be determined depending on actual requirements. Therefore, the slot antenna may be adjusted by the match circuit **400** to a corresponding frequency range to meet the requirements of the antenna.

In order to beautify the appearance of the mobile terminal, in an embodiment of the present disclosure, the slot **100** has a C-shape or a U-shape. In the embodiment of the present disclosure, as shown in FIG. 2, the slot may include a straight line section **111**, a first bent section **112** and a second bent section **113**. The first bent section **112** is connected with

a first end of the straight line section **111** and the second bent section **113** is connected with a second end of the straight line section **111**.

For example, as shown in FIG. 2, the slot **100** may consist of the straight line section **111**, the first bent section **112** and the second bent section **113**. That is, the horizontal section of the slot **100** may be the straight line section **111**. With respect to the slot shown in FIG. 2, the first bent section **112** may be on the left of the straight line section **111** and the second bent section **113** may be on the right of the straight line section **111**. Therefore, based on the appearance and the structure of the C-shape or U-shape of the slot, antenna properties of 2.4 G WIFI/5G WIFI and GPS are achieved because of the structure by single feeding and matching network.

In an embodiment of the present disclosure, in the case of the slot including the straight line section, the first bent section and the second bent section, as shown in FIG. 3, the mobile terminal **10** may include a camera assembly **13**. The feeding point **12** is disposed between the camera assembly **13** and the first bent section **112**.

For example, as shown in FIG. 3, the camera assembly **13** may be disposed at the upper part of the mobile terminal to facilitate the user to shoot a picture using the camera assembly of the mobile terminal. The camera assembly **13** may be a dual camera. The camera assembly **13** is disposed near the first bent section **112**, for example, the camera assembly **13** is disposed on the right of the first bent section **112** and the feeding point **12**. The feeding point **12** is thus disposed between the camera assembly **13** and the first bent section **112**.

In order to fix the camera assembly, in an embodiment of the present disclosure, as shown in FIG. 3, the antenna device further includes a spring assembly **500**, by which the camera assembly **13** is connected with the connecting assembly **200**.

For example, as shown in FIG. 3, the number of the spring assemblies **500** may be two, each of them is arranged at one of two ends of the camera assembly **13**. By the spring assembly **500** arranged at the camera assembly **13**, the camera assembly **13** may be connected with the connecting assemblies **200**. The spring assembly **500** is grounded, by which the camera assembly **13** is fixed. The camera assembly **13** is grounded to avoid its influence on the antenna.

According to the antenna device for the mobile terminal of embodiments of the present disclosure, the slot is defined in the shell of the mobile terminal. The slot separates the shell into a first part and a second part, and the first part is configured to couple with a mainboard via a feeding point to form a slot antenna. The first part and the second part are connected by the connecting assembly. The first capacitor couples the first part with the feeding point. The match circuit couples the first part with the feeding point. That is, due to the structure of the slot, the antenna device may guarantee the efficient radiation or reception of electromagnetic signals even the shell is made of a metal, realize a three-in-one antenna by single feeding and matching network and improve the signal intensity for communication.

In order to realize the above embodiments, a mobile terminal is further provided in embodiments of the present disclosure.

FIG. 4 is a block diagram of a mobile terminal according to an embodiment of the present disclosure. It should be noted that the mobile terminal according to the embodiments of the present disclosure may be a mobile phone, a tablet computer and the like. In an embodiment of the present disclosure, the mobile terminal is a mobile phone.

As shown in FIG. 4, the mobile terminal **10** may include an antenna device **20**. The antenna device **20** may be any antenna device according to any one of the above embodiments. That is, the specific structure and function of the antenna device **20** may refer to the description for the antenna device of any embodiments above in FIG. 1 to FIG. 3, which are no more described in detail here.

According to the mobile terminal of the embodiments of the present disclosure, in the antenna device, the slot is provided in the shell of the mobile terminal. The slot divides the shell into a first part and a second part, and the first part is configured to be connected with a mainboard via a feeding point to form a slot antenna. The connecting assembly connects the first part with the second part. The first capacitor is connected between the first part and the feeding point. The match circuit is connected between the first part and the feeding point. That is, due to the structure of the slot, the antenna device may guarantee the efficient radiation or reception of electromagnetic signals even the shell is made of a metal, realize a three-in-one antenna by single feeding and matching network and improve the signal intensity for communication.

In the specification, it is to be understood that terms such as “central,” “longitudinal,” “lateral,” “length,” “width,” “thickness,” “upper,” “lower,” “front,” “rear,” “left,” “right,” “vertical,” “horizontal,” “top,” “bottom,” “inner,” “outer,” “clockwise,” and “counterclockwise” should be construed to refer to the orientation as then described or as shown in the drawings under discussion. These relative terms are for convenience of description and do not require that the present invention be constructed or operated in a particular orientation.

In addition, terms such as “first” and “second” are used herein for purposes of description and are not intended to indicate or imply relative importance or significance or to imply the number of indicated technical features. Thus, the feature defined with “first” and “second” may comprise one or more of this feature. In the description of the present disclosure, “a plurality of” means two or more than two, unless specified otherwise.

In the description of the present disclosure, it should be understood that, unless specified or limited otherwise, the terms “mounted,” “connected,” “coupled” and “fixed” and variations thereof are used broadly and encompass such as mechanical or electrical mountings, connections and couplings, also can be inner mountings, connections and couplings of two components, and further can be direct and indirect mountings, connections, and couplings, which can be understood by those skilled in the art according to the detail embodiment of the present disclosure.

In the present invention, unless specified or limited otherwise, a structure in which a first feature is “on” or “below” a second feature may include an embodiment in which the first feature is in direct contact with the second feature, and may also include an embodiment in which the first feature and the second feature are not in direct contact with each other, but are contacted via an additional feature formed therebetween. Furthermore, a first feature “on,” “above,” or “on top of” a second feature may include an embodiment in which the first feature is right or obliquely “on,” “above,” or “on top of” the second feature, or just means that the first feature is at a height higher than that of the second feature; while a first feature “below,” “under,” or “on bottom of” a second feature may include an embodiment in which the first feature is right or obliquely “below,” “under,” or “on bottom of” the second feature, or just means that the first feature is at a height lower than that of the second feature.

Reference throughout this specification to “an embodiment,” “some embodiments,” “one embodiment,” “another example,” “an example,” “a specific example,” or “some examples,” means that a particular feature, structure, material, or characteristic described in connection with the embodiment or example is included in at least one embodiment or example of the present disclosure. Thus, the appearances of the phrases such as “in some embodiments,” “in one embodiment,” “in an embodiment,” “in another example,” “in an example,” “in a specific example,” or “in some examples,” in various places throughout this specification are not necessarily referring to the same embodiment or example of the present disclosure. Furthermore, the particular features, structures, materials, or characteristics may be combined in any suitable manner in one or more embodiments or examples.

Although explanatory embodiments have been shown and described, it would be appreciated by those skilled in the art that the above embodiments cannot be construed to limit the present disclosure, and changes, alternatives, and modifications can be made in the embodiments without departing from spirit, principles and scope of the present disclosure.

What is claimed is:

1. An antenna device for a mobile terminal, comprising a slot, defined in a shell of the mobile terminal, wherein the slot separates the shell into a first part and a second part, and the first part is configured to couple with a mainboard via a feeding point to form a slot antenna;

- a connecting assembly, connecting the first part with the second part;
- a first capacitor, coupling the first part with the feeding point; and
- a match circuit, coupling the first part with the feeding point, wherein the match circuit comprises:
 - a second capacitor;
 - a first inductor connected with the second capacitor.

2. The antenna device of claim 1, wherein the slot antenna covers a frequency in a range of at least one of 2.4 to 2.48 GHz and 5.1 to 5.85 GHz to form a WIFI communication antenna and the slot antenna is adjusted to cover the frequency in a range of 1.5 to 1.6 GHz by the match circuit to form a GPS antenna.

3. The antenna device of claim 1, wherein the slot has a C-shape or a U-shape.

4. The antenna device of claim 1, wherein the slot comprises:

- a straight line section comprising a first end and a second end opposite to the first end;
- a first bent section connected with the first end of the straight line section; and
- a second bent section connected with the second end of the straight line section.

5. The antenna device of claim 1, wherein the connecting assembly is a metal connecting sheet.

6. The antenna device of claim 5, wherein the connecting assembly is connected with the first part and the second part by means of laser welding.

7. The antenna device of claim 5, wherein number of the connecting assemblies is 1 to 4.

8. The antenna device of claim 1, wherein the slot is filled with an insulator.

9. The antenna device of claim 8, wherein the insulator is a plastic material.

10. A mobile terminal, comprising:

- a shell,
- a mainboard, and
- an antenna device comprising:
 - a slot provided in the shell of the mobile terminal, wherein the slot divides the shell into a first part and a second part, and the first part is coupled to the mainboard via a feeding point to form a slot antenna;
 - a connecting assembly connecting the first part to the second part;
 - a first capacitor connected between the first part and the feeding point; and
 - a match circuit connected between the first part and the feeding point, wherein the match circuit comprises:
 - a second capacitor;
 - a first inductor connected with the second capacitor.

11. The mobile terminal of claim 10, wherein the slot antenna covers a frequency in a range of at least one of 2.4 to 2.48 GHz and 5.1 to 5.85 GHz to form a WIFI communication antenna and the slot antenna is adjusted to cover the frequency in a range of 1.5 to 1.6 GHz by the match circuit to form a GPS antenna.

12. The mobile terminal of claim 10, wherein the slot has a C-shape or a U-shape.

13. The mobile terminal of claim 10, wherein the slot comprises:

- a straight line section comprising a first end and a second end opposite to the first end;
- a first bent section extending from the first end of the straight line section; and
- a second bent section extending from the second end of the straight line section.

14. The mobile terminal of claim 13, further comprising a camera assembly, wherein the feeding point is disposed between the camera assembly and the first bent section.

15. The mobile terminal of claim 14, wherein the antenna device further comprises a spring assembly, wherein the camera assembly is connected with the connecting assembly by the spring assembly.

16. The mobile terminal of claim 10, wherein the connecting assembly is a metal connecting sheet.

17. The mobile terminal of claim 16, wherein the connecting assembly is connected with the first part and the second part by means of laser welding.

18. The mobile terminal of claim 16, wherein number of the connecting assemblies is 1 to 4.

* * * * *