



(19) **United States**

(12) **Patent Application Publication**
Conboy

(10) **Pub. No.: US 2019/0168033 A1**

(43) **Pub. Date: Jun. 6, 2019**

(54) **METHOD OF AND APPARATUS FOR APPLYING FIRE AND SMOKE INHIBITING COMPOSITIONS ON GROUND SURFACES BEFORE THE INCIDENCE OF WILD-FIRES, AND ALSO THEREAFTER, UPON SMOLDERING AMBERS AND ASHES TO REDUCE SMOKE AND SUPPRESS FIRE RE-IGNITION**

Related U.S. Application Data

(63) Continuation-in-part of application No. 15/866,451, filed on Jan. 9, 2018, which is a continuation-in-part of application No. 15/829,914, filed on Dec. 2, 2017, now Pat. No. 10,260,232.

Publication Classification

(51) **Int. Cl.**
A62C 2/00 (2006.01)
(52) **U.S. Cl.**
CPC *A62C 2/00* (2013.01)

(71) Applicant: **M-Fire Suppression, Inc.**, Carlsbad, CA (US)

(72) Inventor: **Stephen Conboy**, Carlsbad, CA (US)

(73) Assignee: **M-Fire Suppression, Inc.**, Carlsbad, CA (US)

(57) **ABSTRACT**

A method of and apparatus for making and applying a clean fire and smoke inhibiting slurry composition containing clean fire inhibiting chemicals, and cellulose or wood fiber, mixed with water and other additives, on surfaces including ground surfaces in advance of wild fire, to blanket grounds from wildfire ignition, and also application over smoldering ambers and ashes to prevent re-ignition while reducing (i) the use of significant amounts of water, (ii) the production of toxic run off water, and (iii) toxic smoke.

(21) Appl. No.: **15/911,172**

(22) Filed: **Mar. 5, 2018**

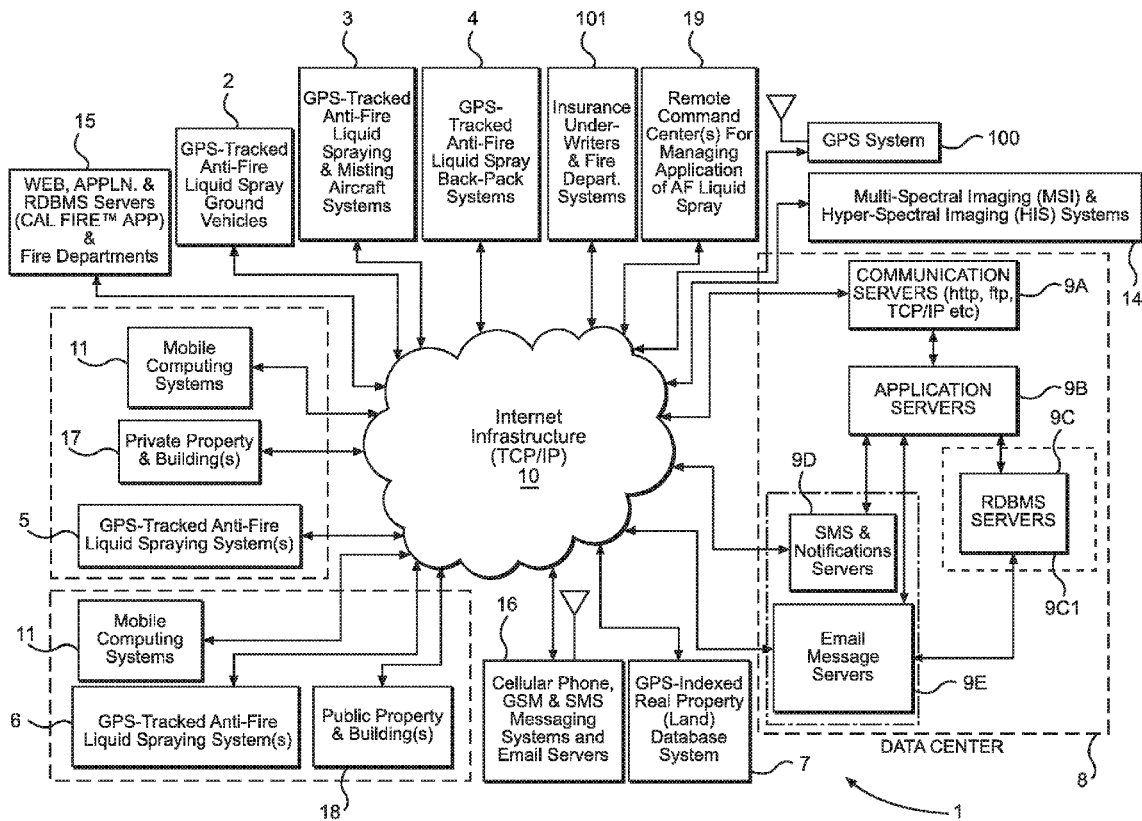

CONVENTIONAL METHODS FOR FIGHTING AND DEFENDING AGAINST WILD FIRES

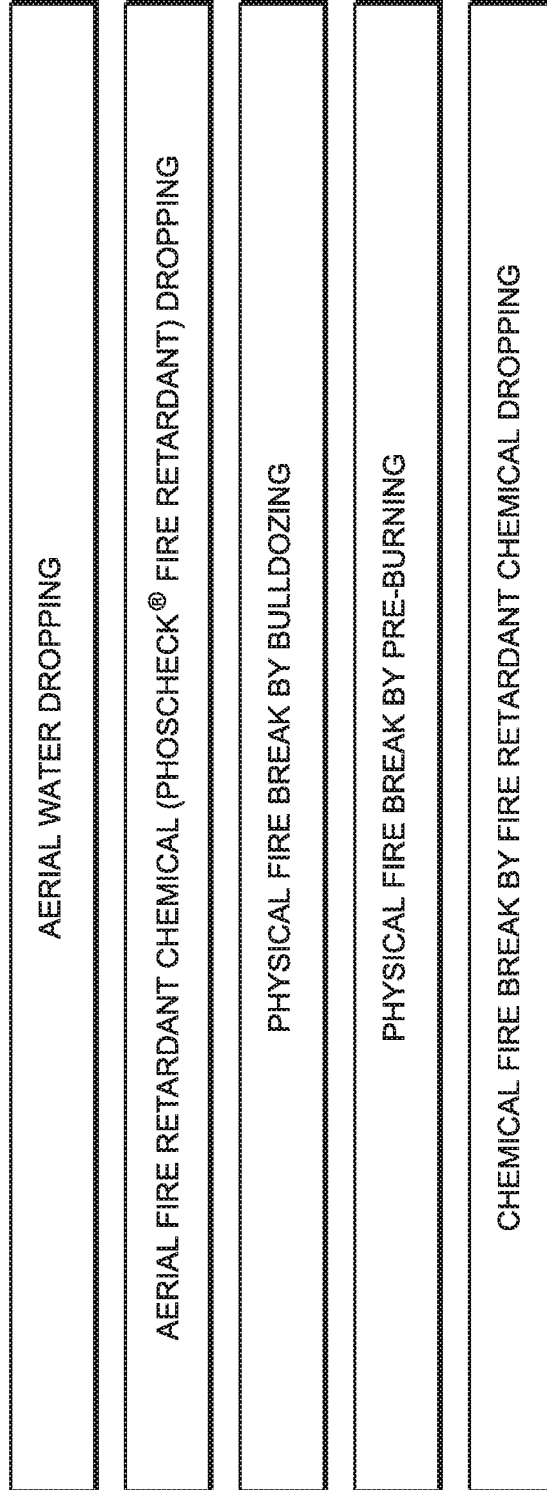

FIG. 1
(PRIOR ART)

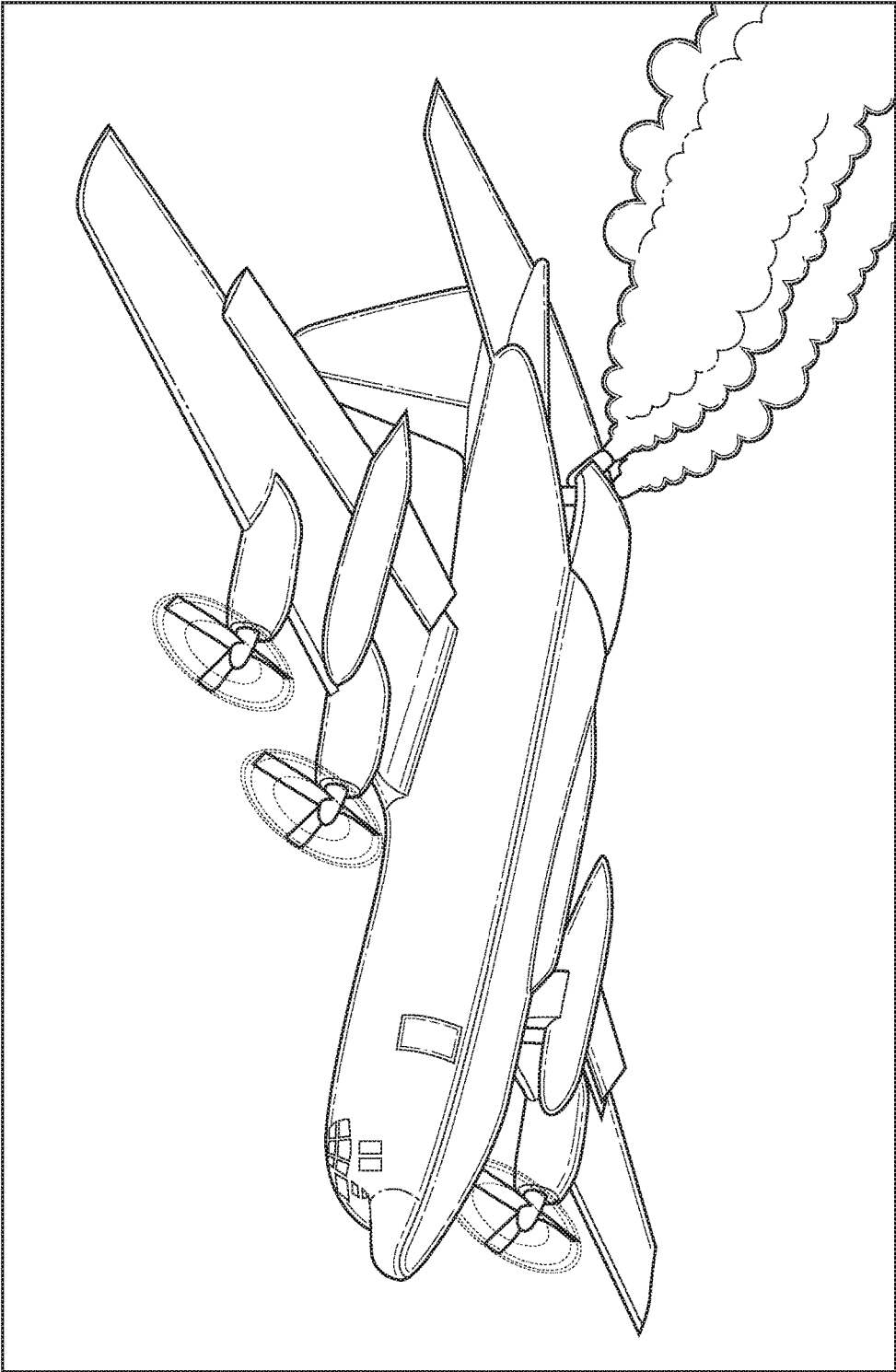

FIG. 2A
(PRIOR ART)

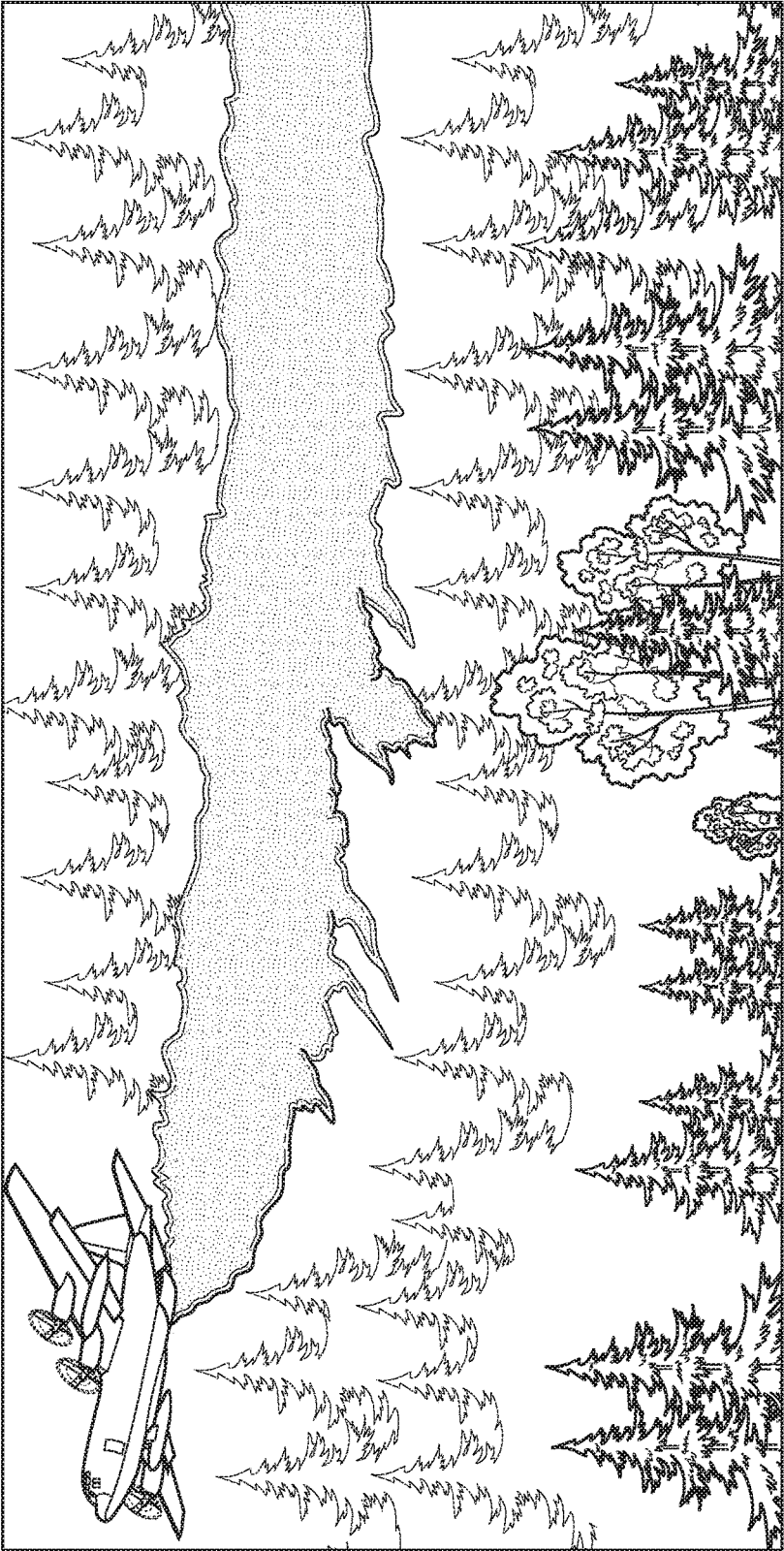

FIG. 2B1
(PRIOR ART)

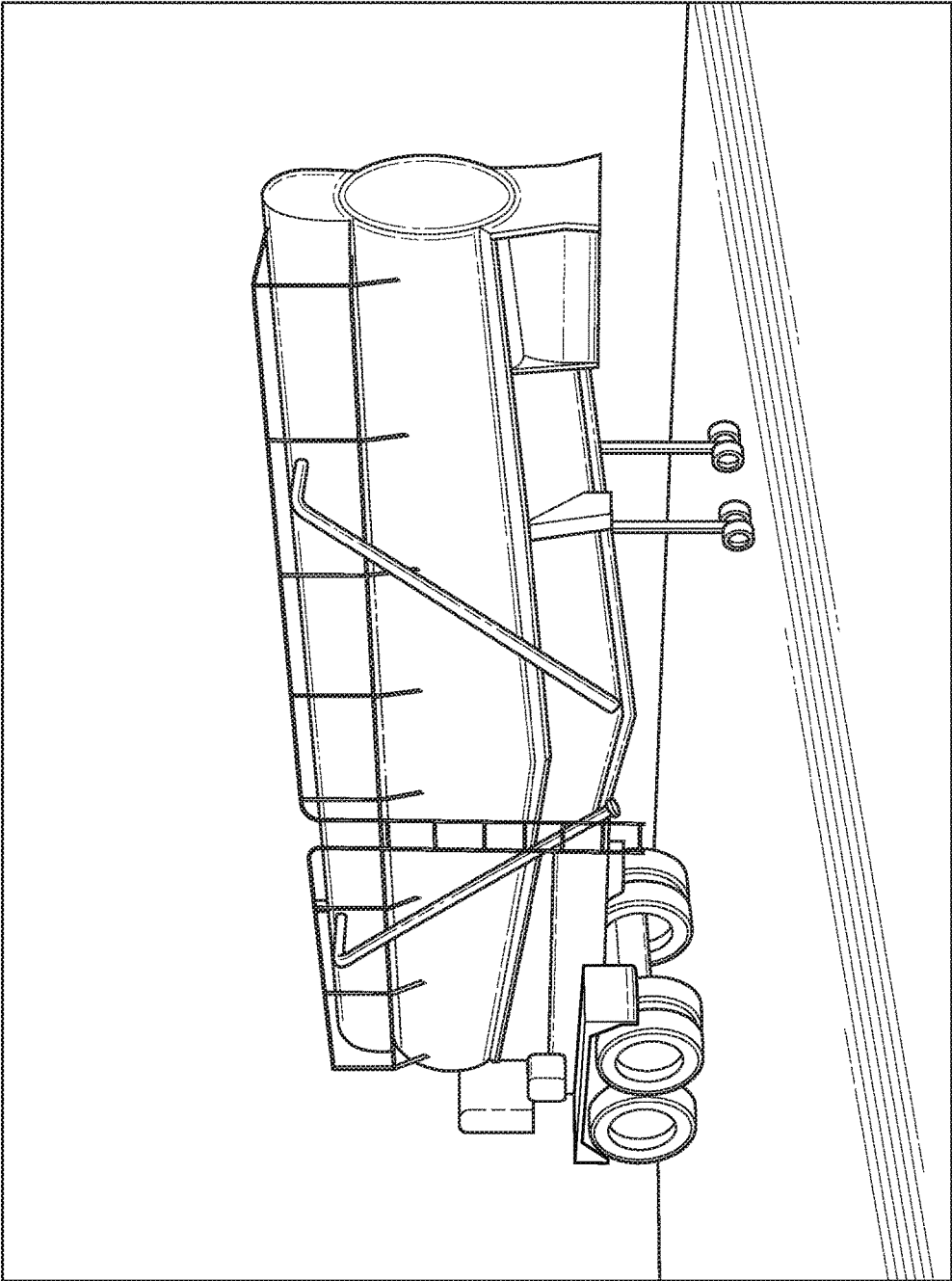

FIG. 2B2
(PRIOR ART)

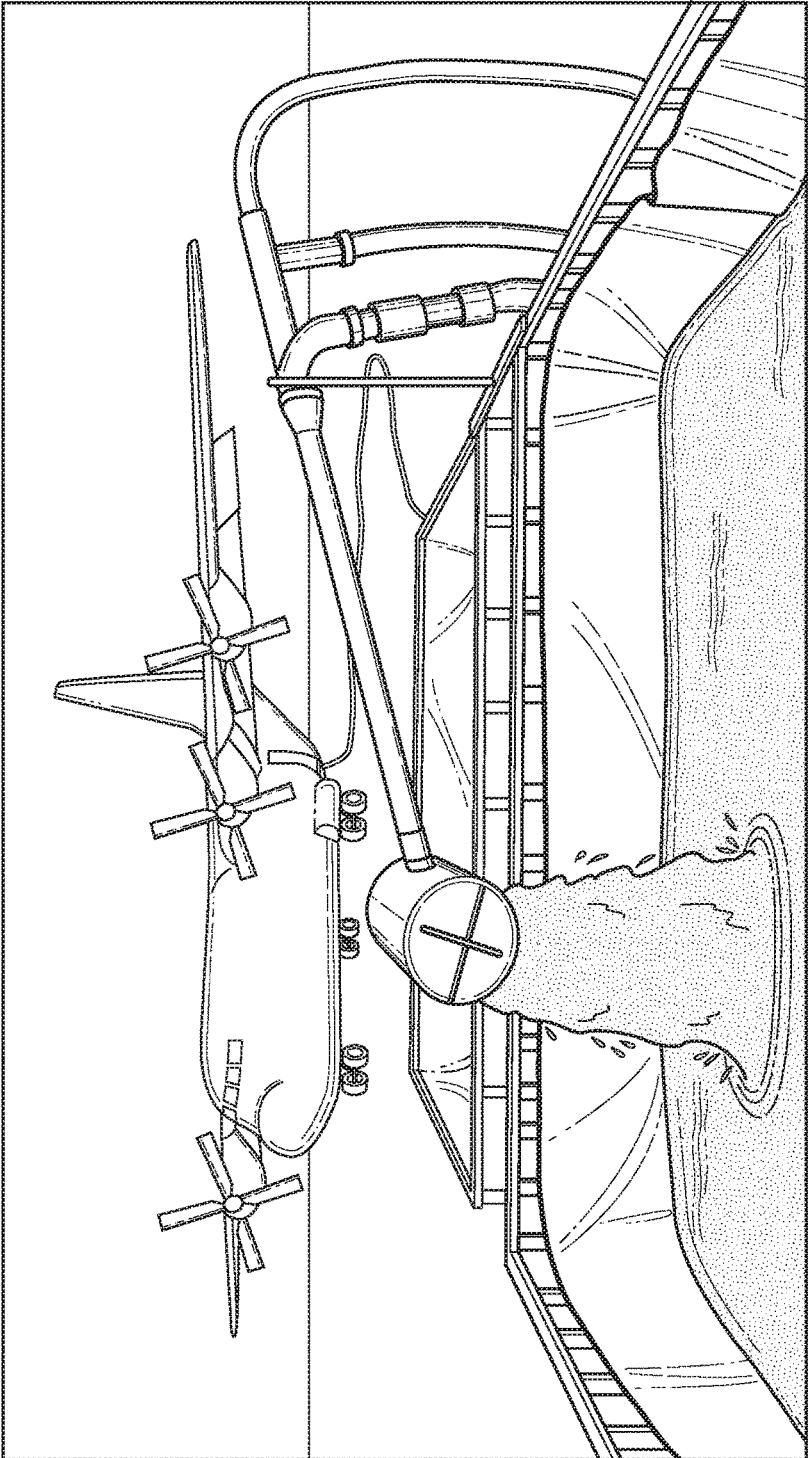

FIG. 2B3
(PRIOR ART)

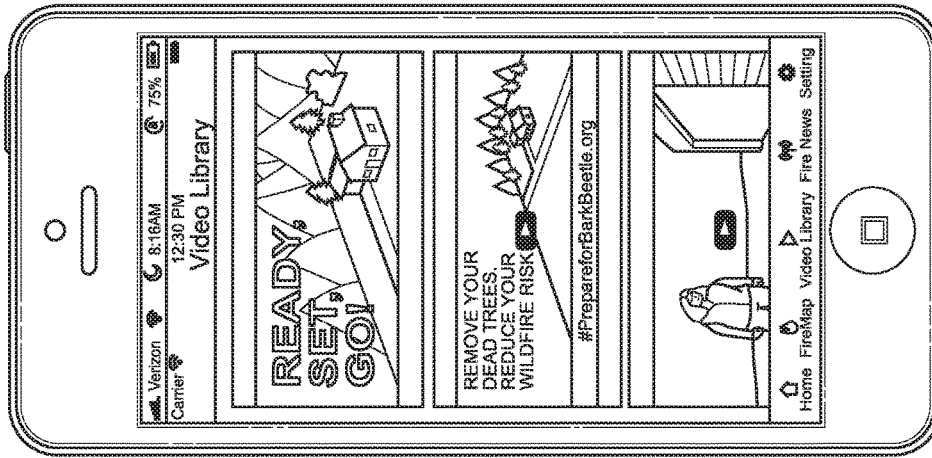

FIG. 3B
(PRIOR ART)

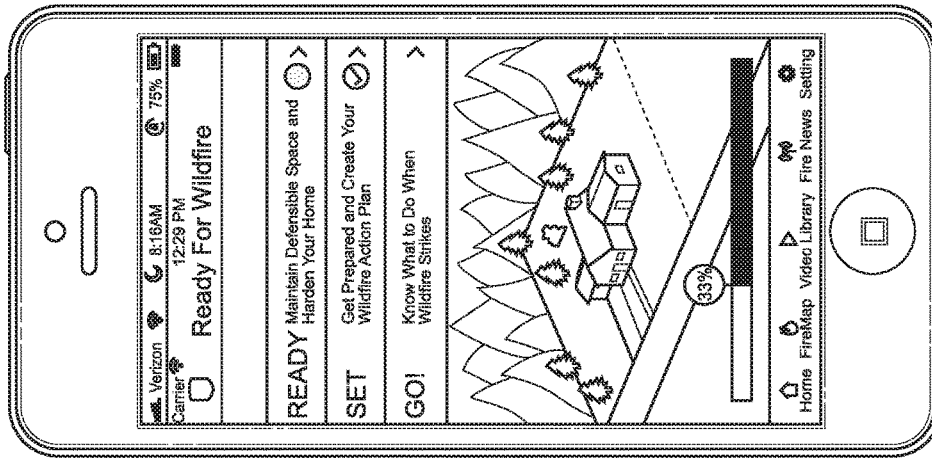

FIG. 3A
(PRIOR ART)

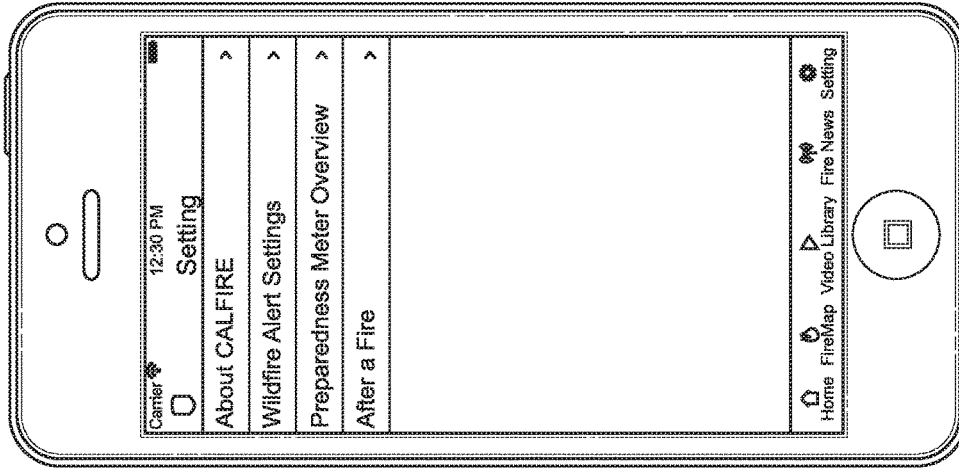

FIG. 3E
(PRIOR ART)

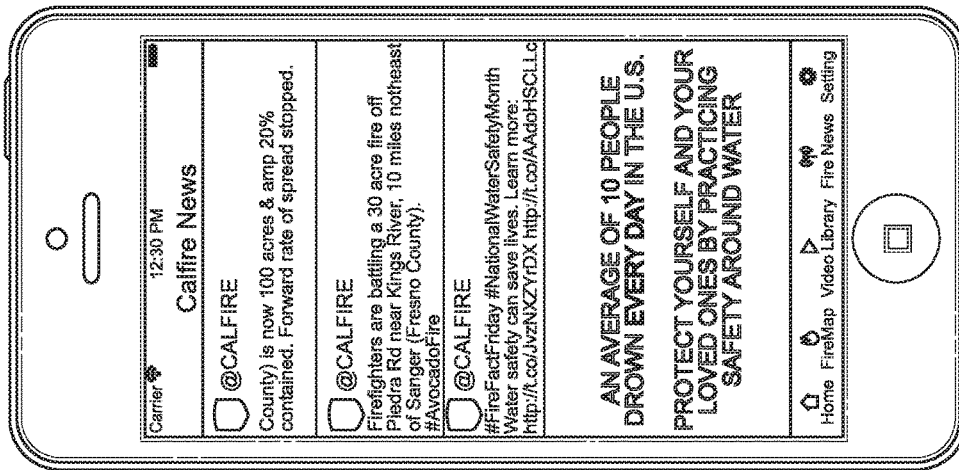

FIG. 3D
(PRIOR ART)

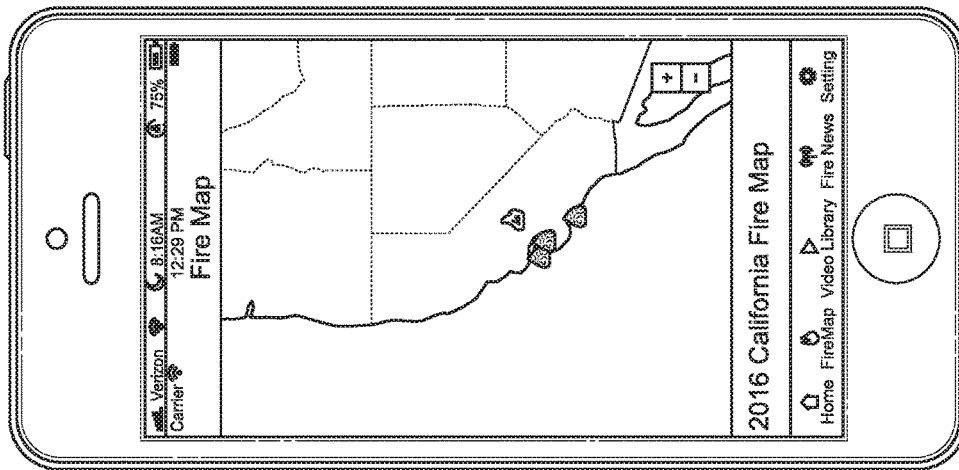

FIG. 3C
(PRIOR ART)

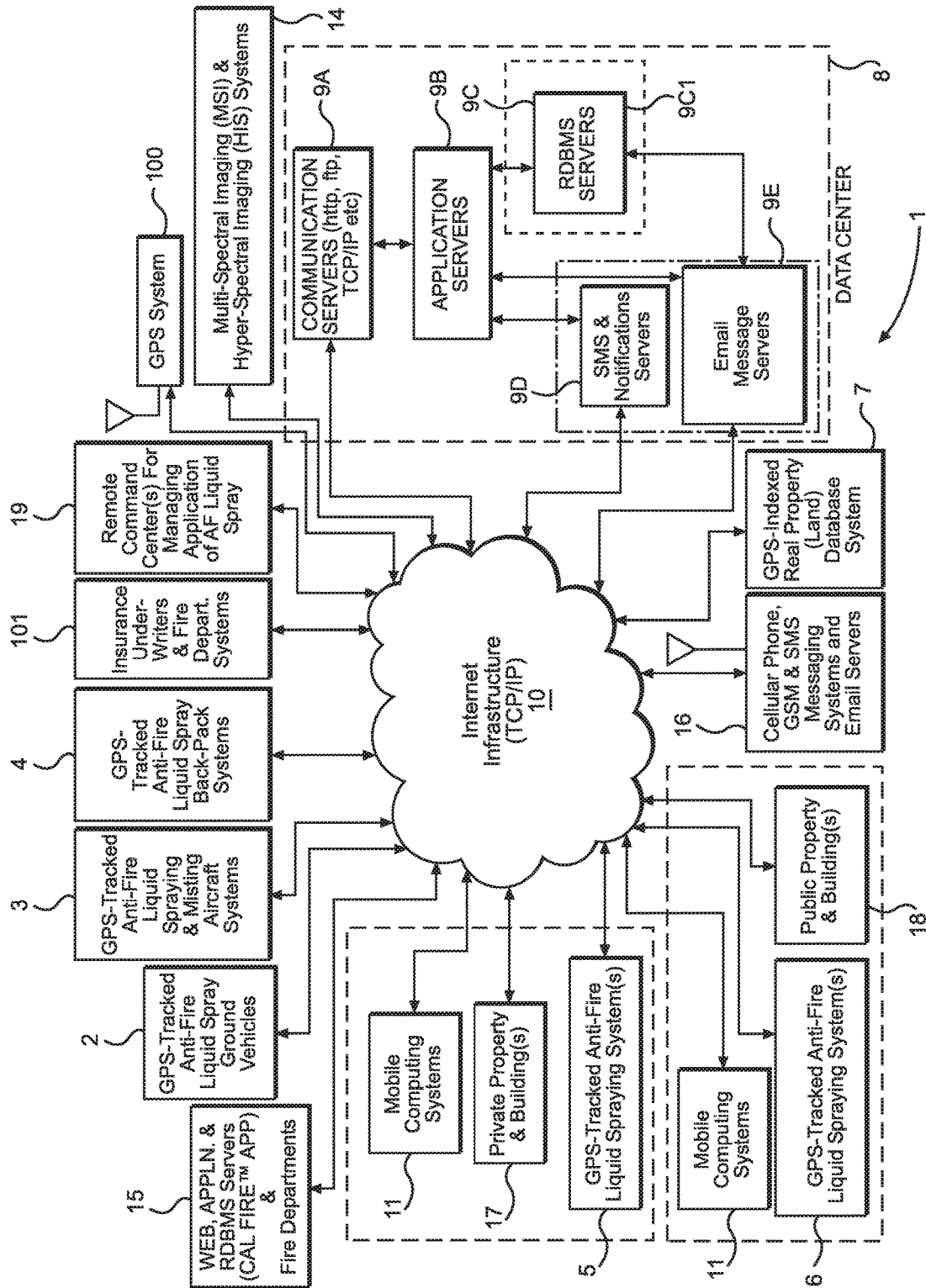

FIG. 4

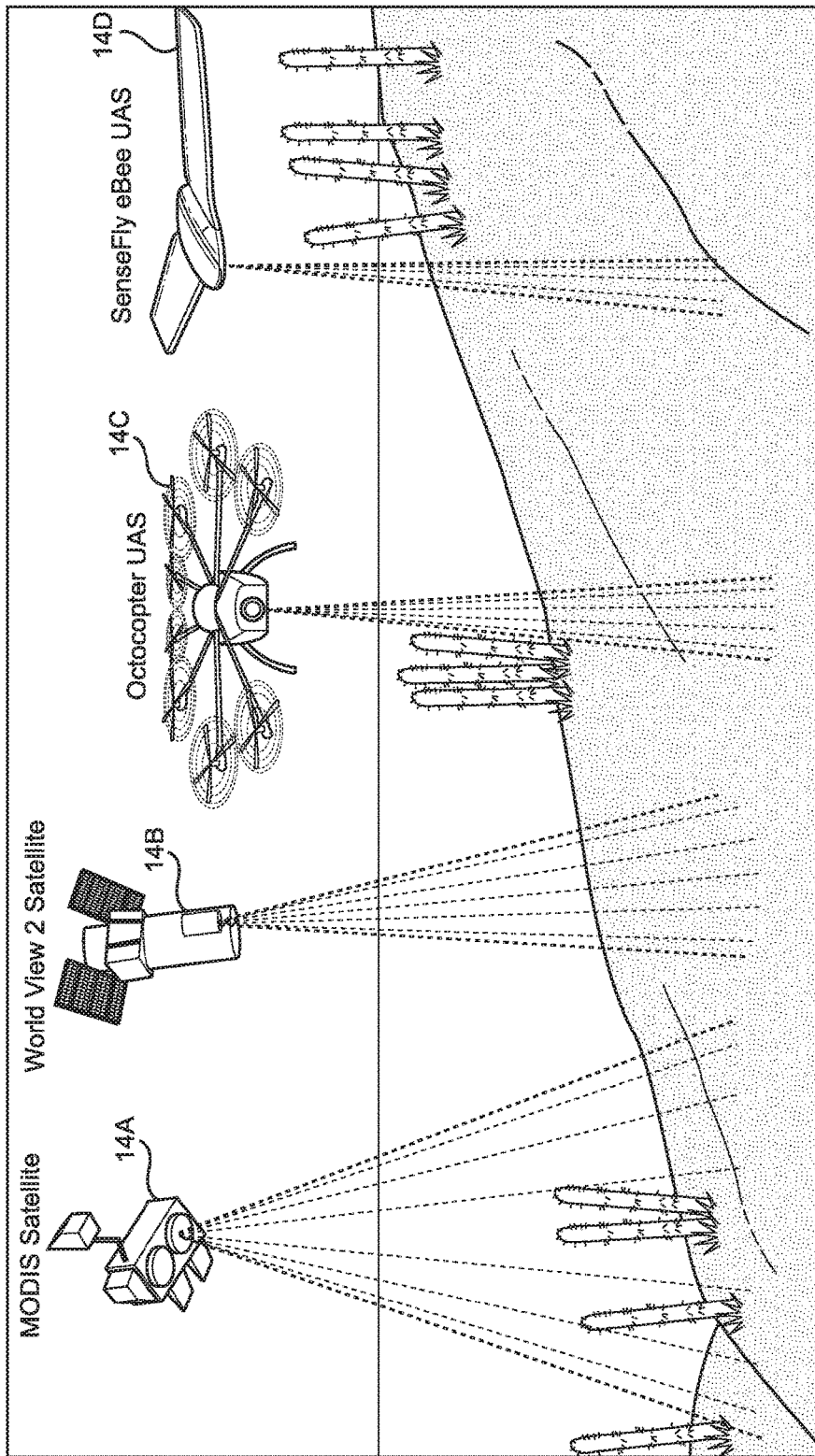

FIG. 4A

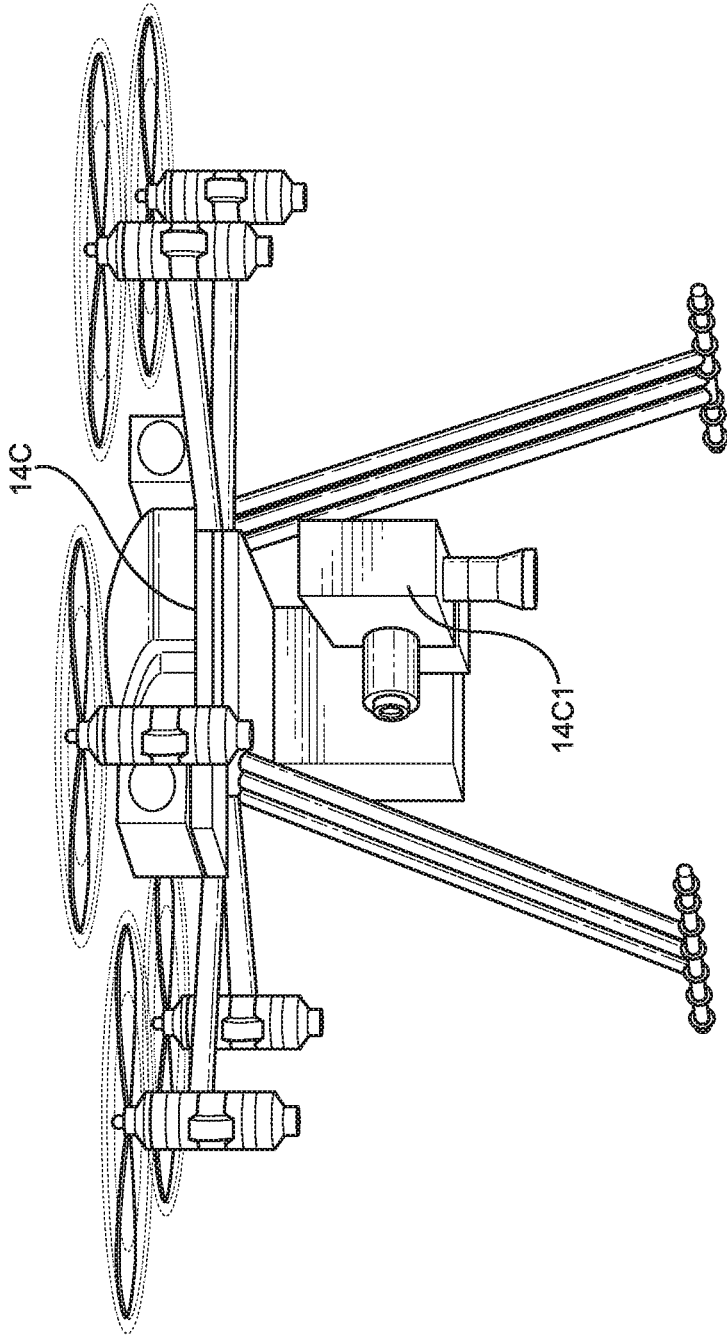

FIG. 4B

MOBILE COMPUTING DEVICES DEPLOYED ON THE SYSTEM NETWORK OF THE PRESENT INVENTION

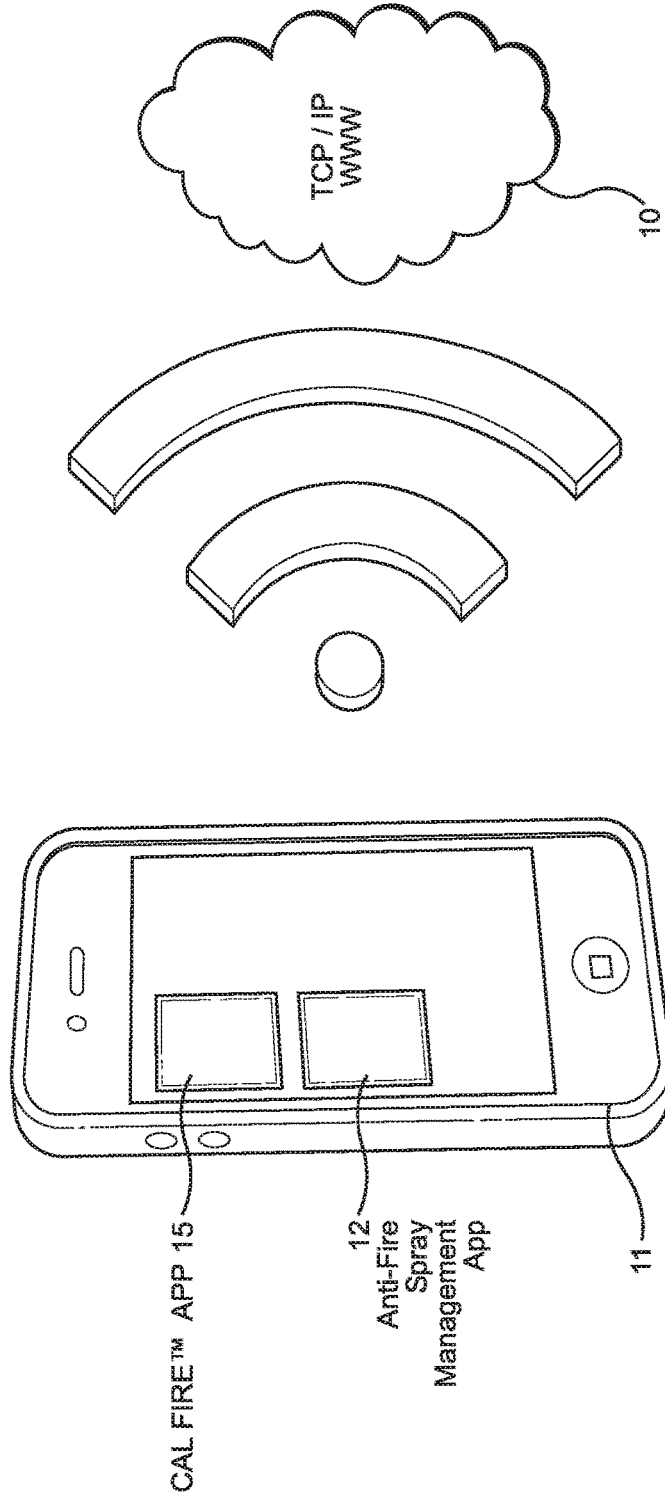

FIG. 5A

**GENERAL SYSTEM ARCHITECTURE
OF MOBILE CLIENT SYSTEM**

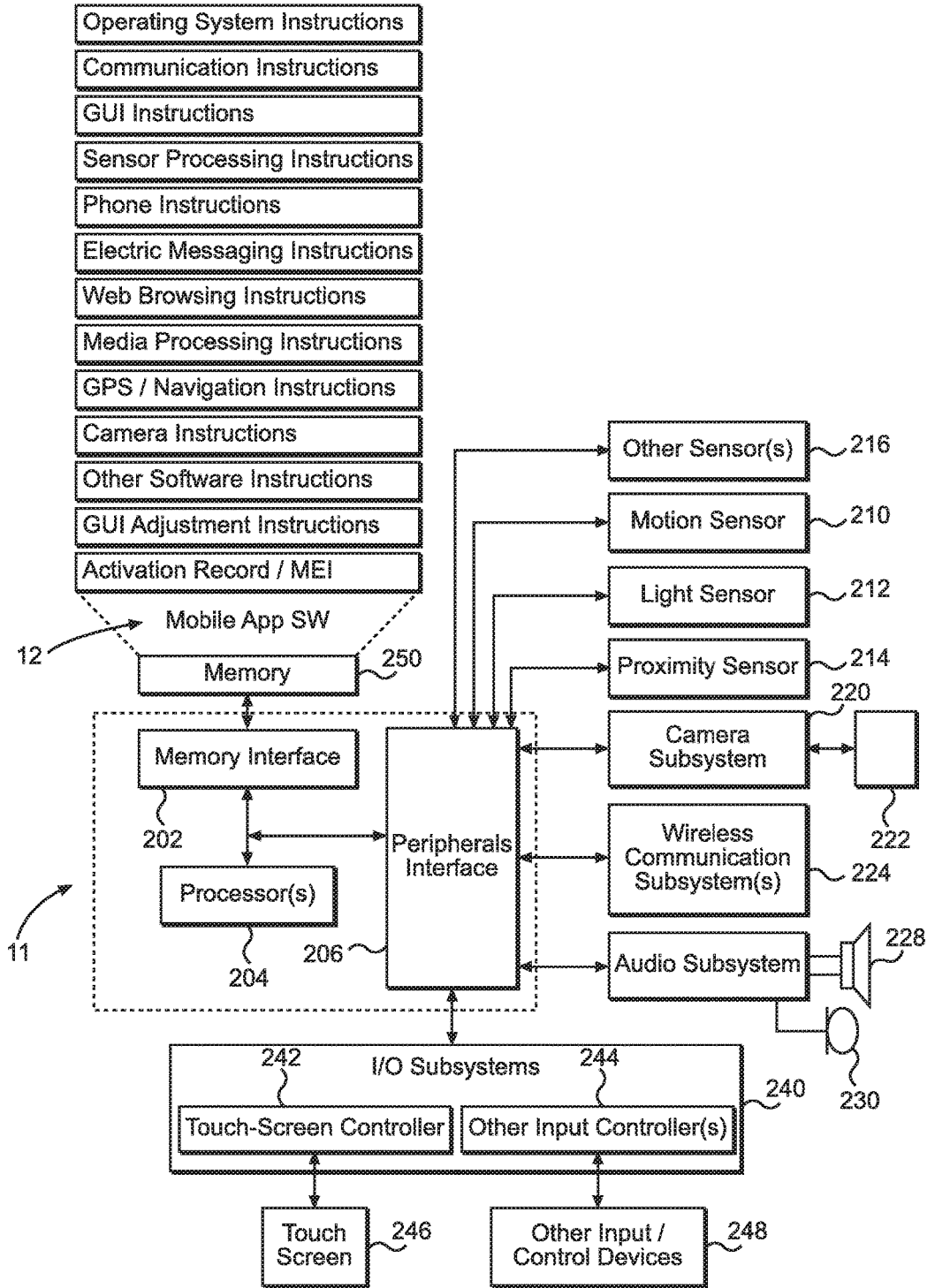

FIG. 5B

GPS-TRACKED MOBILE ANTI-FIRE (AF) CHEMICAL LIQUID SPRAY SYSTEM

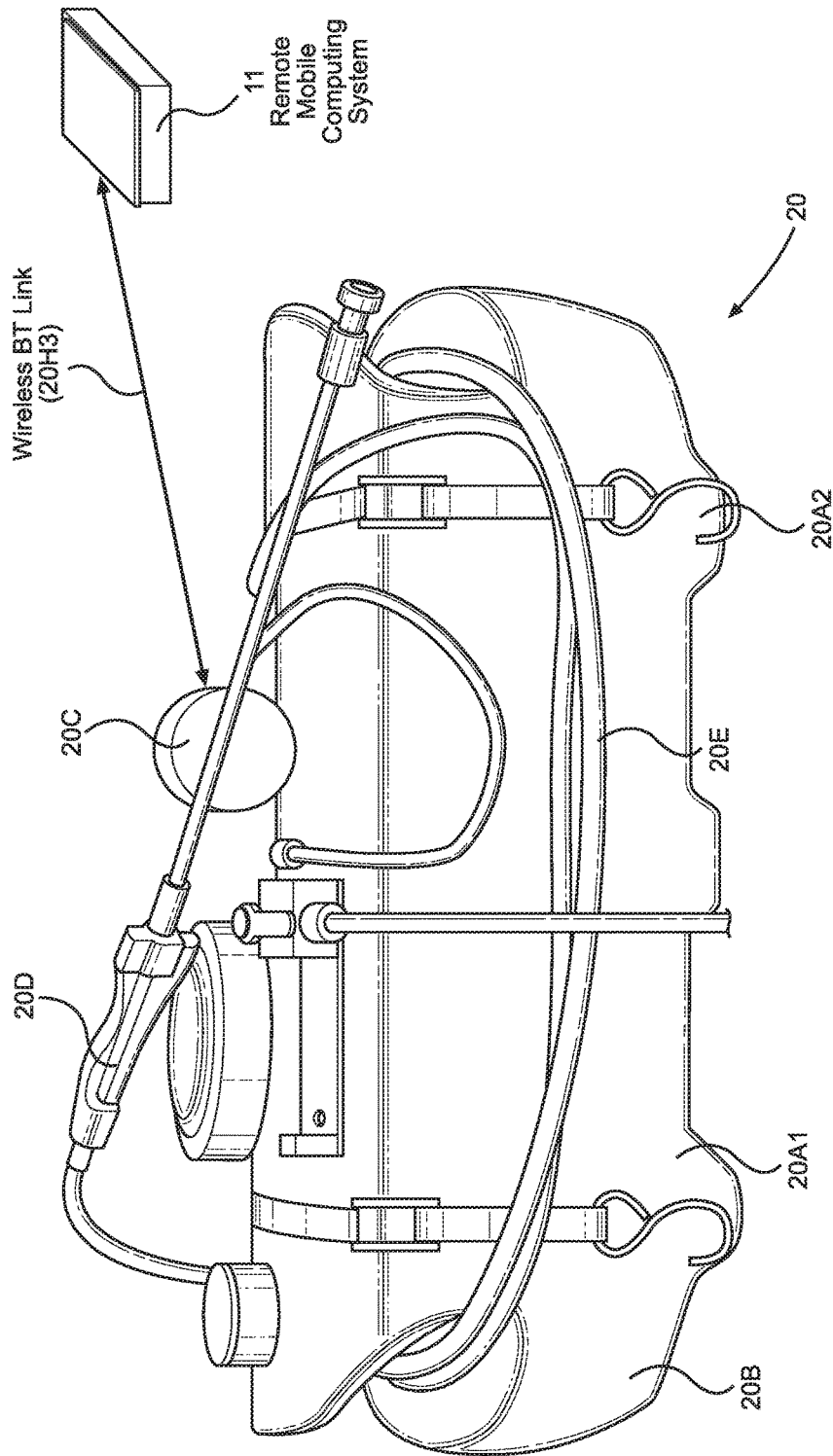

FIG. 6A

GPS-TRACKED MOBILE ANTI-FIRE (AF) CHEMICAL LIQUID SPRAY SYSTEM

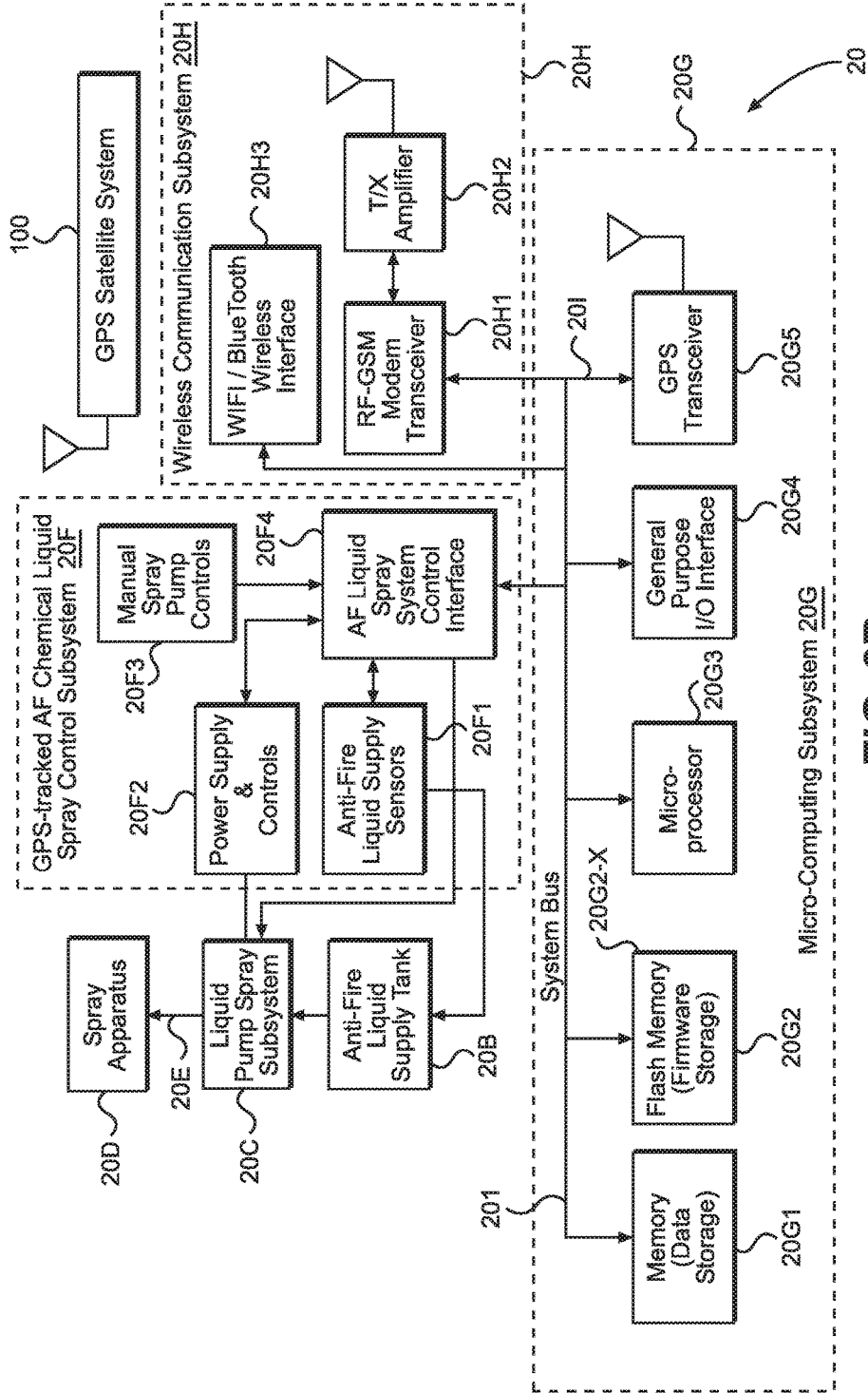

FIG. 6B

GPS-TRACKED MANNED OR AUTONOMOUS VEHICLE FOR SPRAYING ANTI-FIRE (AF) CHEMICAL LIQUID ON GROUND SURFACES TO CREATE FIRE BREAK REGIONS IN HIGH RISK AREAS

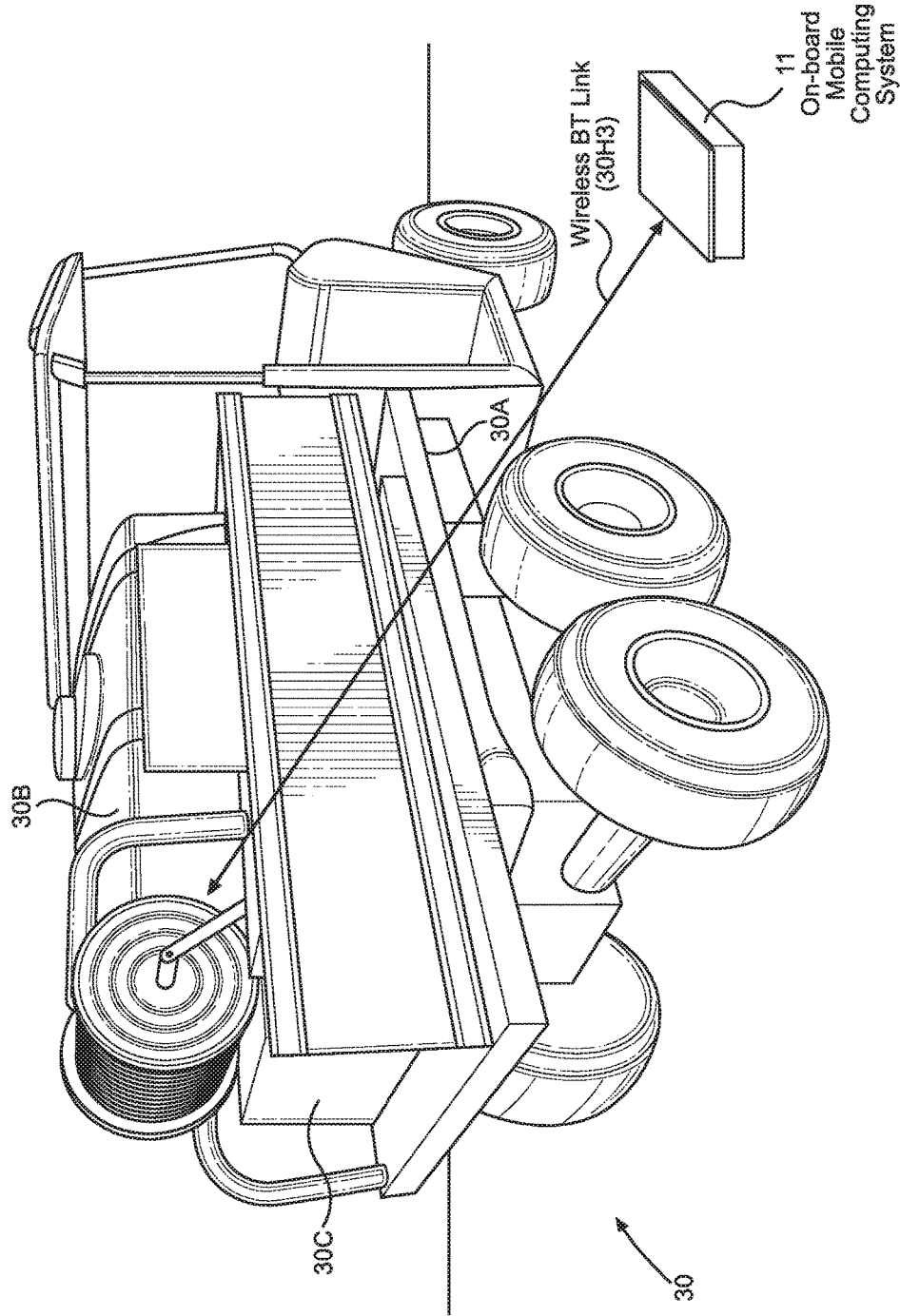

FIG. 7A

GPS-TRACKED MANNED OR AUTONOMOUS VEHICLE FOR SPRAYING ANTI-FIRE (AF) CHEMICAL LIQUID ON GROUND SURFACES TO CREATE FIRE BREAK REGIONS ON HIGH RISK AREAS

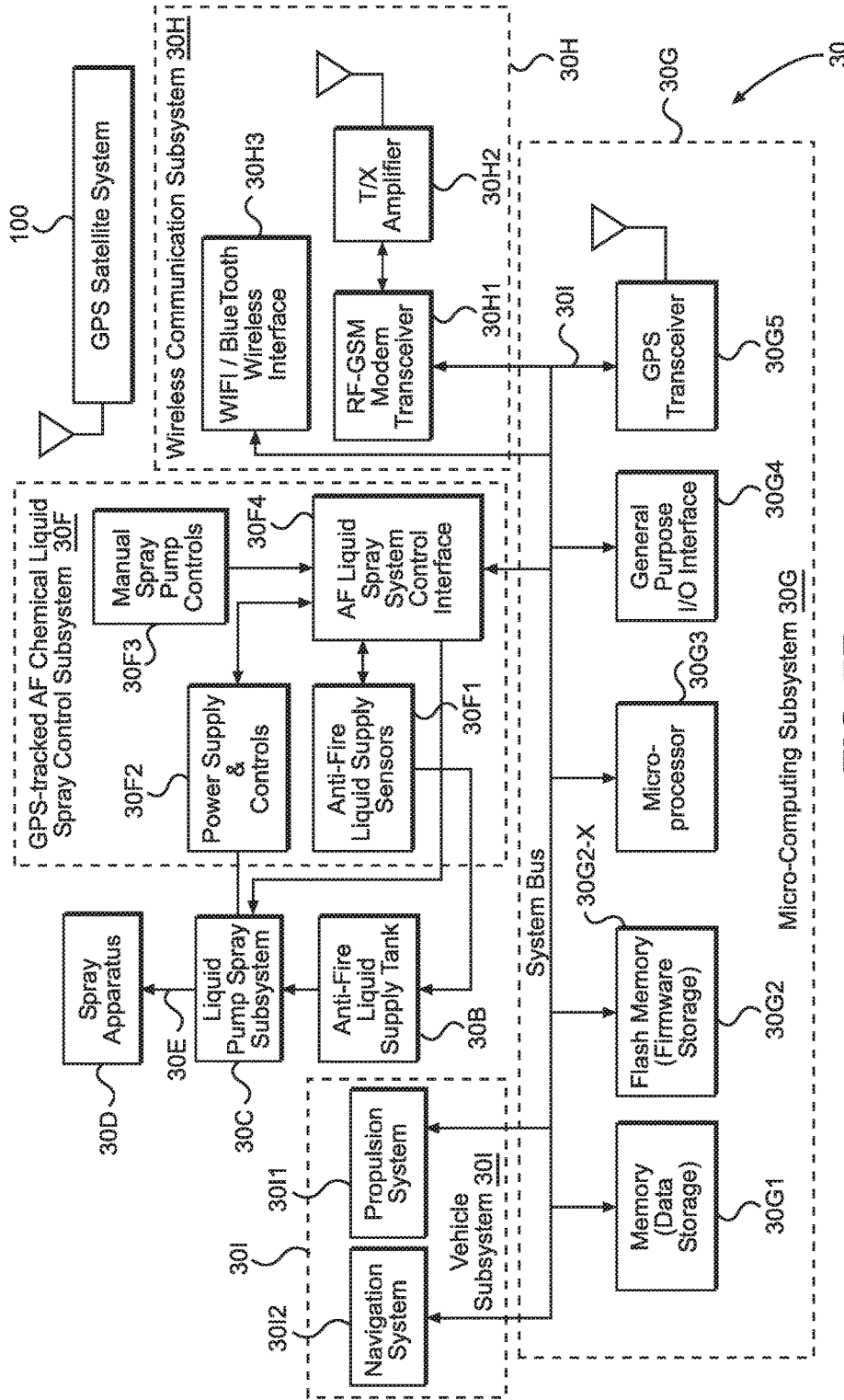

FIG. 7B

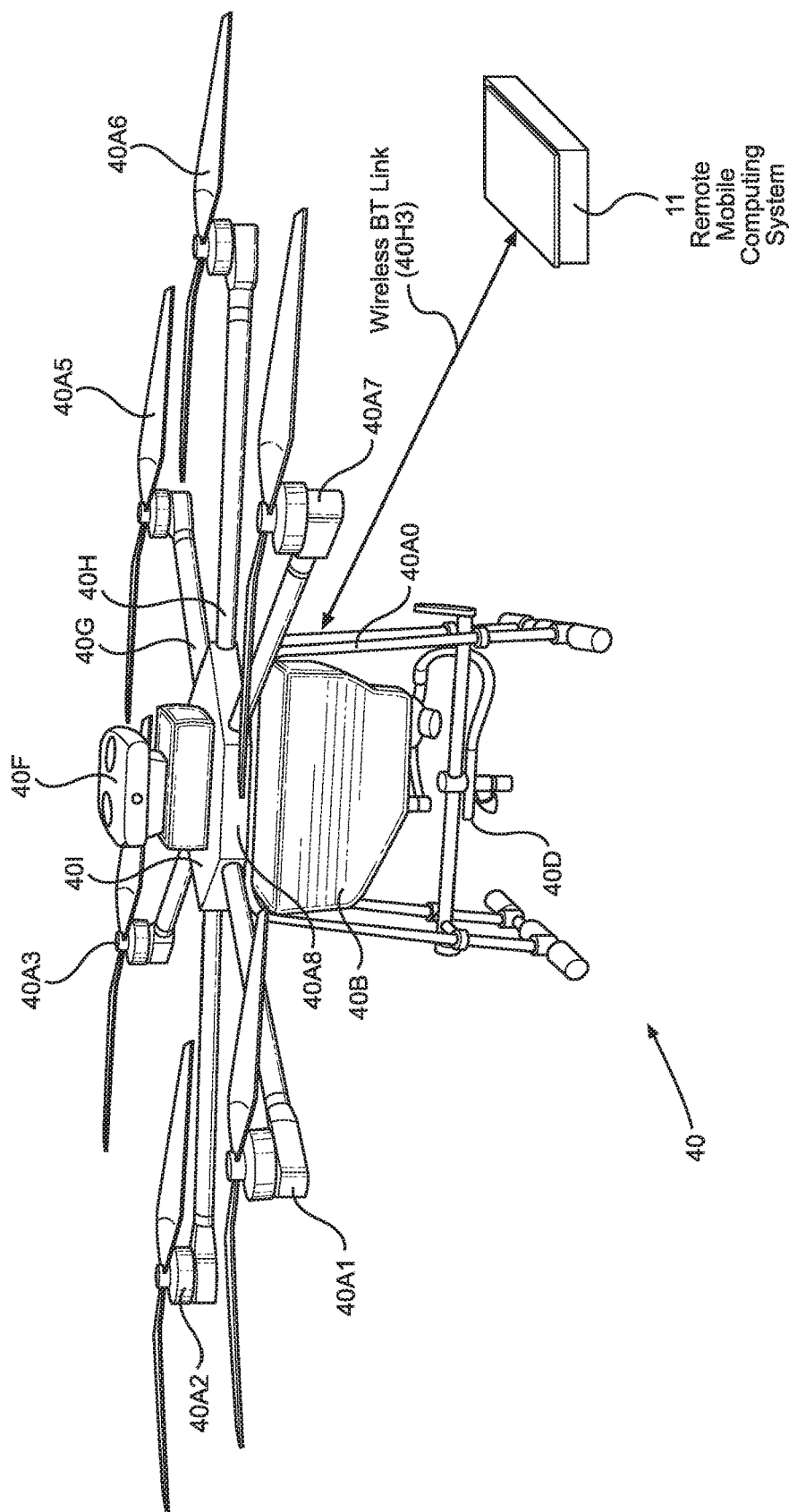

FIG. 8A

AUTONOMOUS (DRONE) AIRCRAFT SYSTEM FOR SPRAYING HOUSES, BUILDINGS AND GROUND SURFACES WITH ANTI-FIRE (AF) CHEMICAL LIQUID

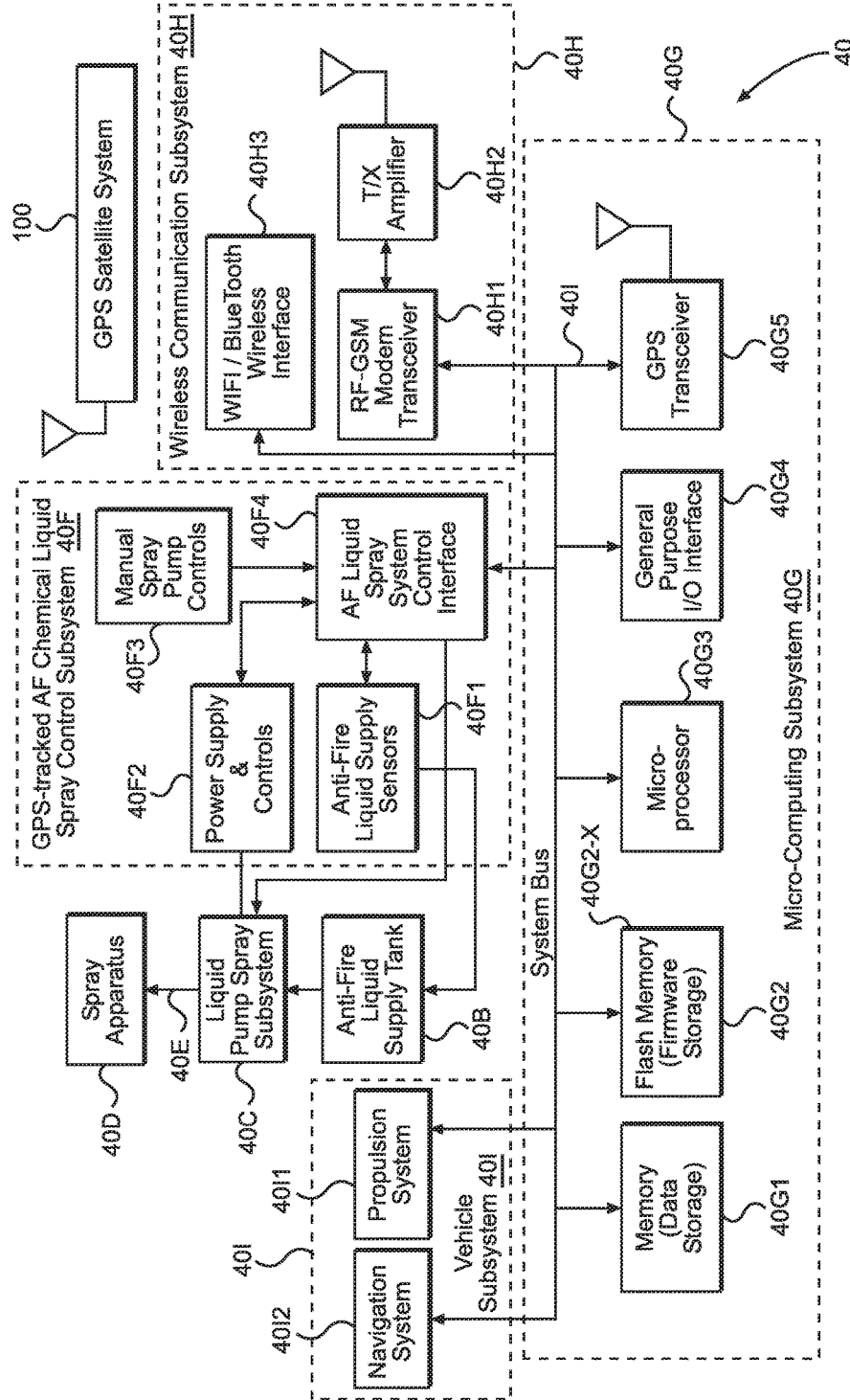

FIG. 8B

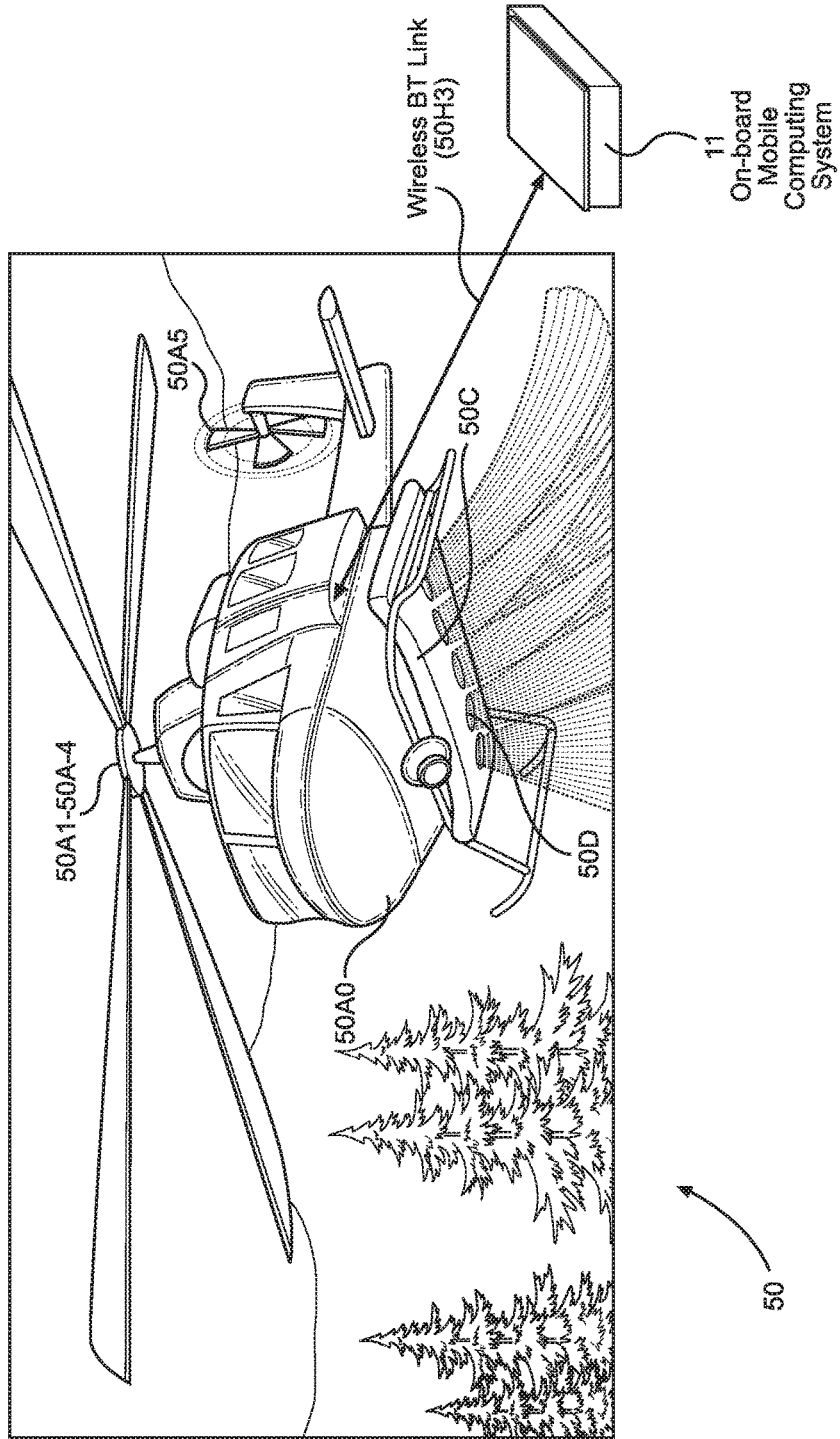

FIG. 9A

**GPS-TRACKED (HELICOPTER) AIRCRAFT SYSTEM FOR SPRAYING FORESTS
GROUND SURFACES WITH ANTI-FIRE (AF) CHEMICAL LIQUID**

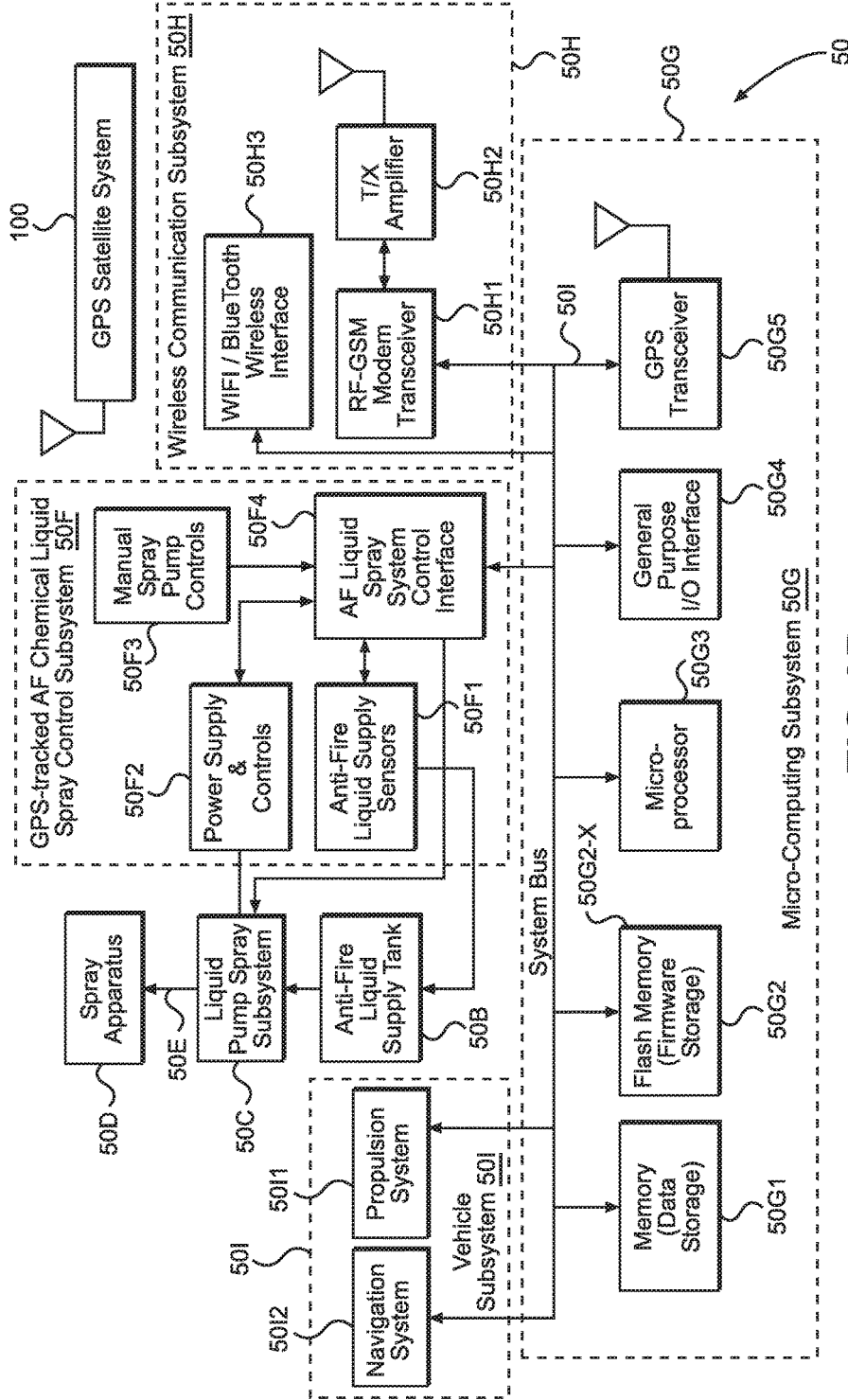

FIG. 9B

**GPS-TRACKED ALL TERRAIN VEHICLE (ATV) SYSTEM FOR SPRAYING
GROUND SURFACES WITH ANTI-FIRE (AF) CHEMICAL LIQUID**

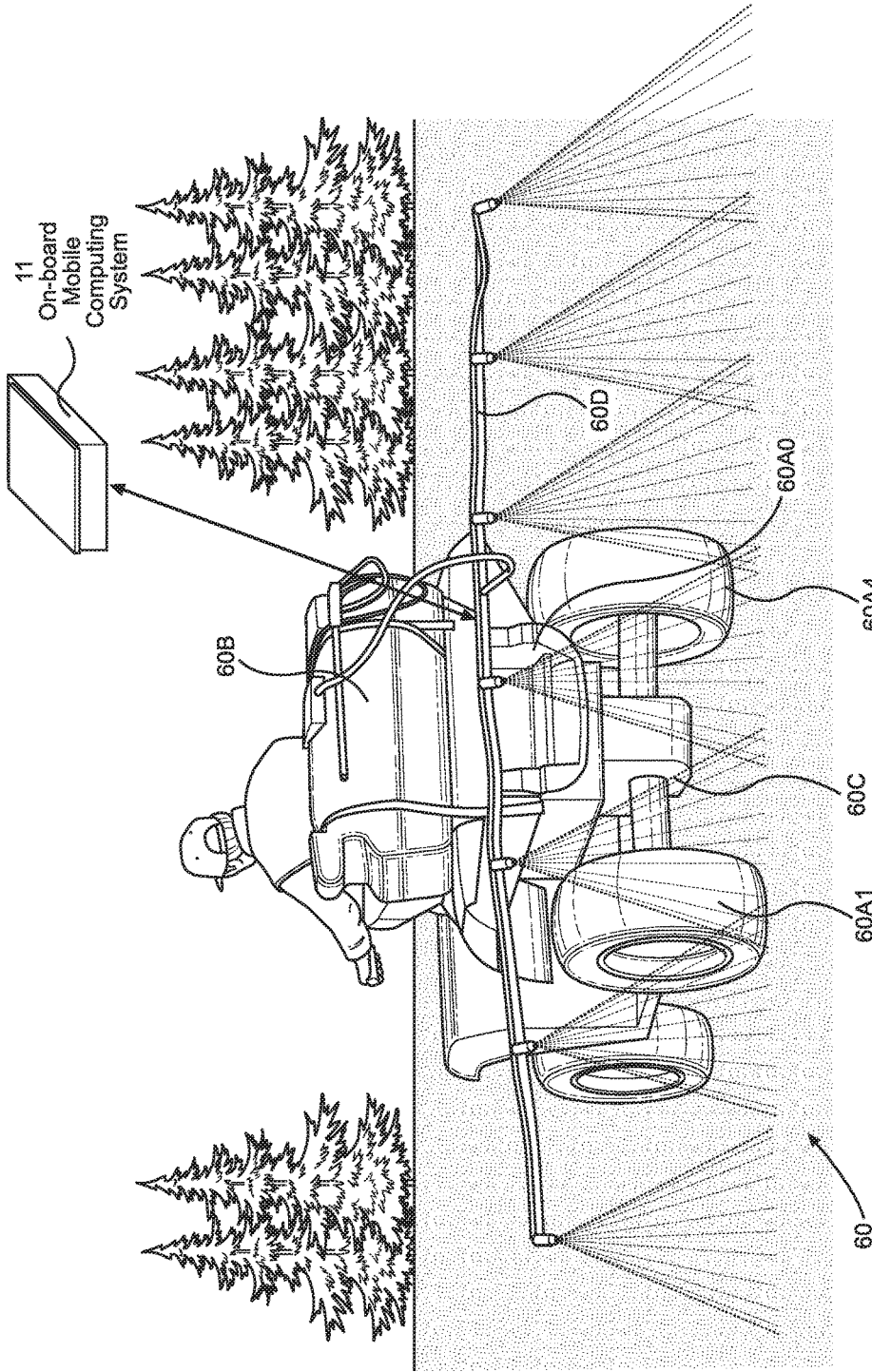

FIG. 10A

**GPS-TRACKED ALL TERRAIN VEHICLE (ATV) SYSTEM FOR SPRAYING
GROUND SURFACES WITH ANTI-FIRE (AF) CHEMICAL LIQUID**

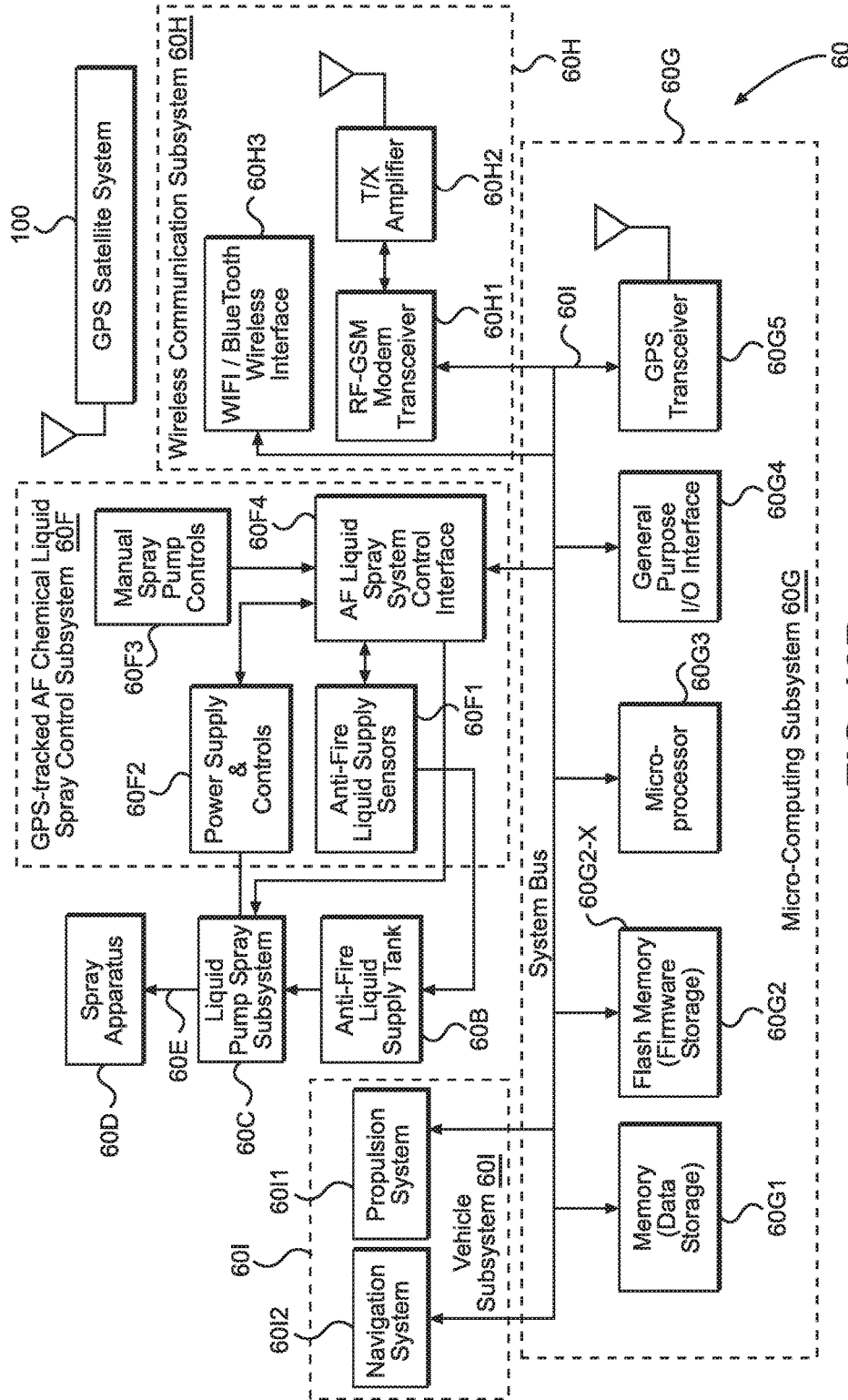

FIG. 10B

SCHEMA FOR NETWORK DATABASE SUPPORTED BY SYSTEM NETWORK OF THE PRESENT INVENTION

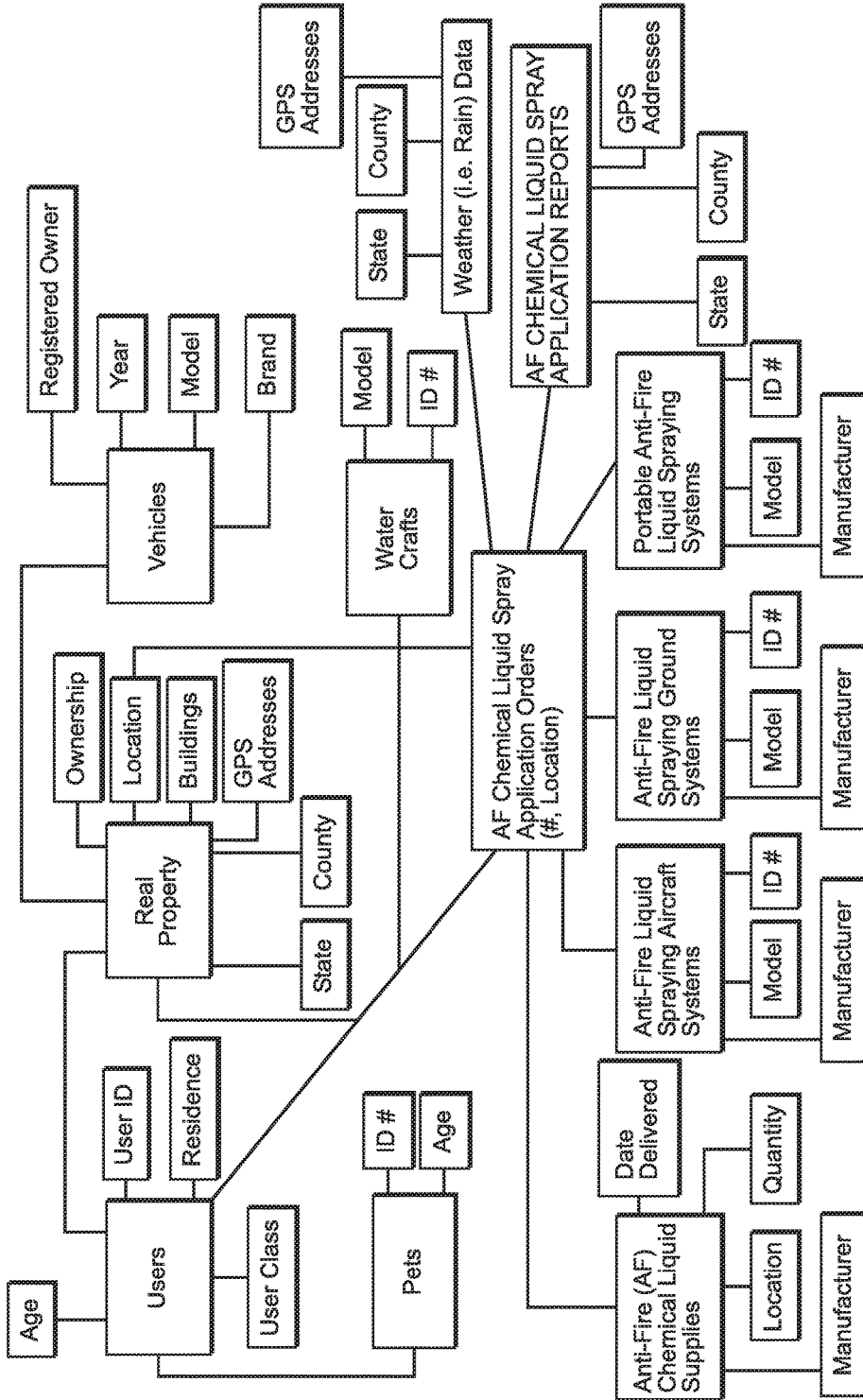

FIG. 11

GRAPHICAL USER INTERFACE SUPPORTED BY MOBILE APPLICATION FOR USE BY REGISTERED USERS (E.G. PROPERTY PARCEL OWNERS, CONTRACTORS AND/OR AGENTS, RESIDENTS, OFFICES, ET AL)

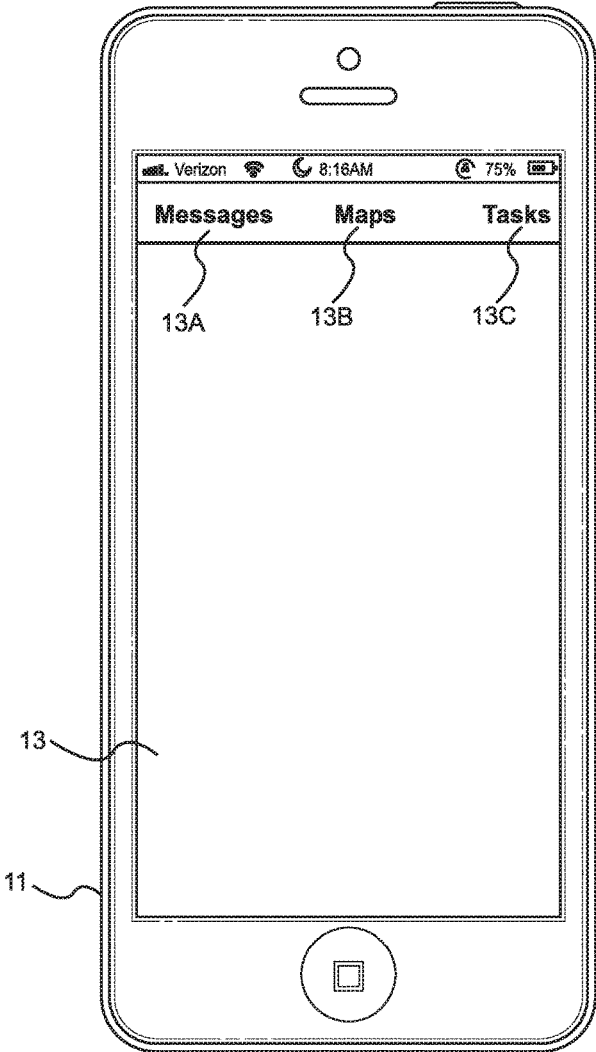

FIG. 12

GRAPHICAL INTERFACE SUPPORTED BY THE MOBILE APPLICATION SHOWING A USER UPDATING THE REGISTRATION PROFILE AS A TASK ON THE SYSTEM NETWORK

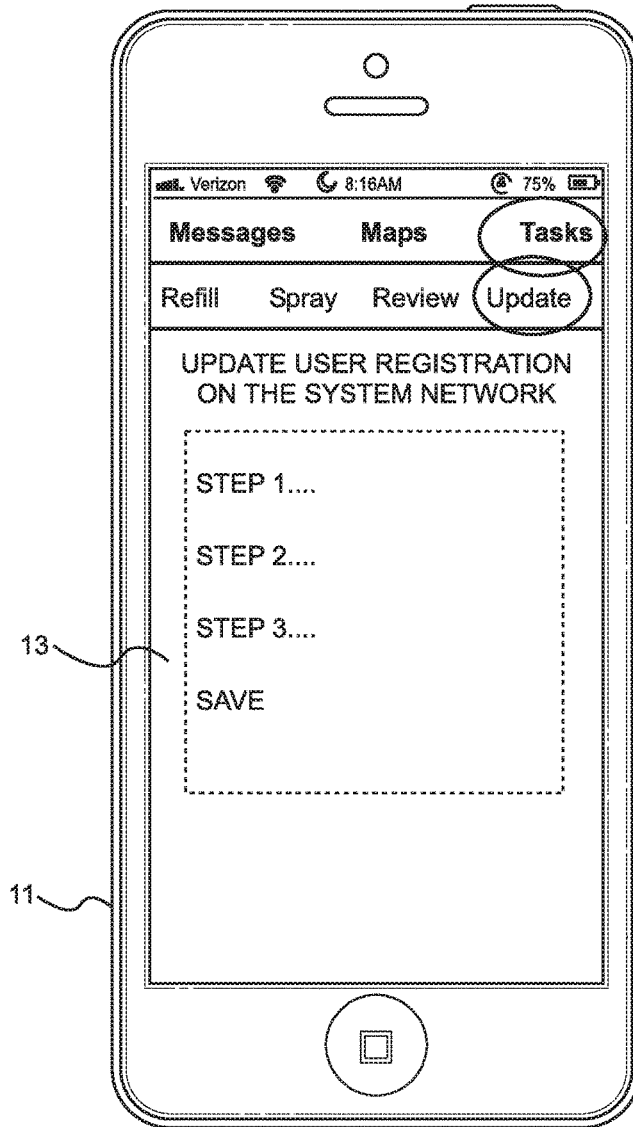

FIG. 12A

GRAPHICAL USER INTERFACE OF THE MOBILE APPLICATION SHOWING A USER RECEIVING A MESSAGE REQUEST FROM THE COMMAND CENTER TO SPRAY GPS-SPECIFIED PRIVATE PROPERTY PARCEL(S) WITH CLEAN ANTI-FIRE (AF) CHEMICAL LIQUID

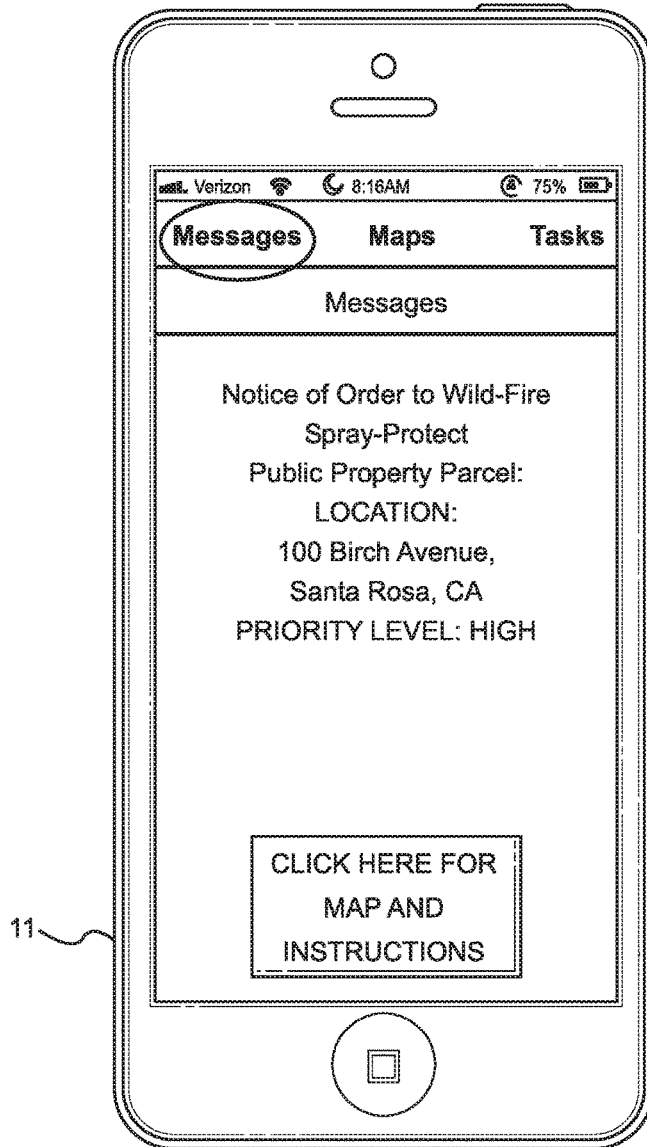

FIG. 12B

GRAPHICAL USER INTERFACE SUPPORTED BY THE MOBILE APPLICATION SHOWING A USER RECEIVING A REQUEST / NOTICE OF ORDER TO WILD-FIRE SPRAY-PROTECT GPS-SPECIFIED PUBLIC PROPERTY PARCEL(S) WITH CLEAN AF LIQUID TO CREATE GPS-SPECIFIED PUBLIC FIREBREAK

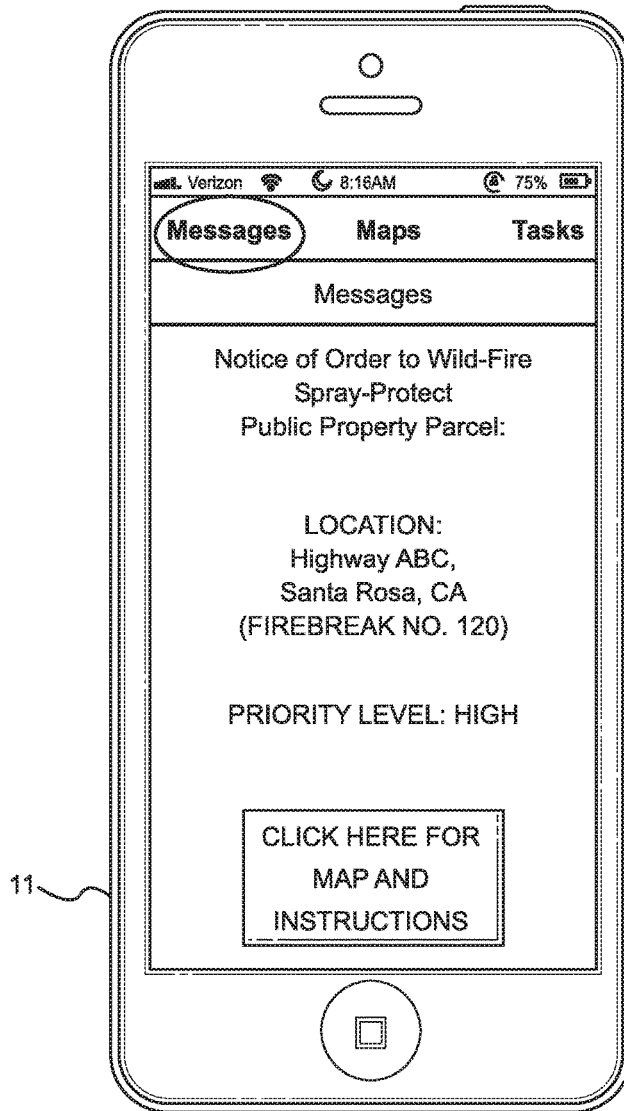

FIG. 12C

GRAPHICAL USER INTERFACE SUPPORTED BY THE MOBILE APPLICATION
SHOWING A USER REQUESTING A REFILL OF CLEAN ANTI-FIRE (AF) CHEMICAL
LIQUID FOR SUPPLY TO GPS-SPECIFIED SPRAY EQUIPMENT

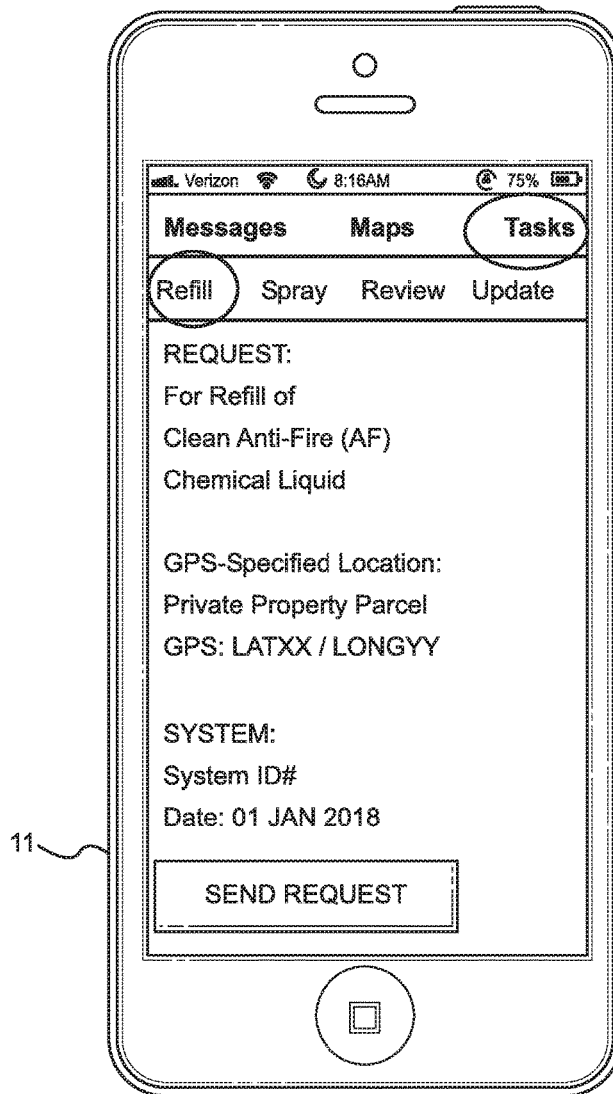

FIG. 12D

GRAPHICAL USER INTERFACE SUPPORTED BY MOBILE APPLICATION FOR USE BY COMMAND CENTER ADMINISTRATORS TO ISSUE WILD-FIRE PROTECTION ORDERS, PLAN WILD-FIRE PROTECTION TASKS, GENERATE REPORTS, AND SEND AND RECEIVE MESSAGES

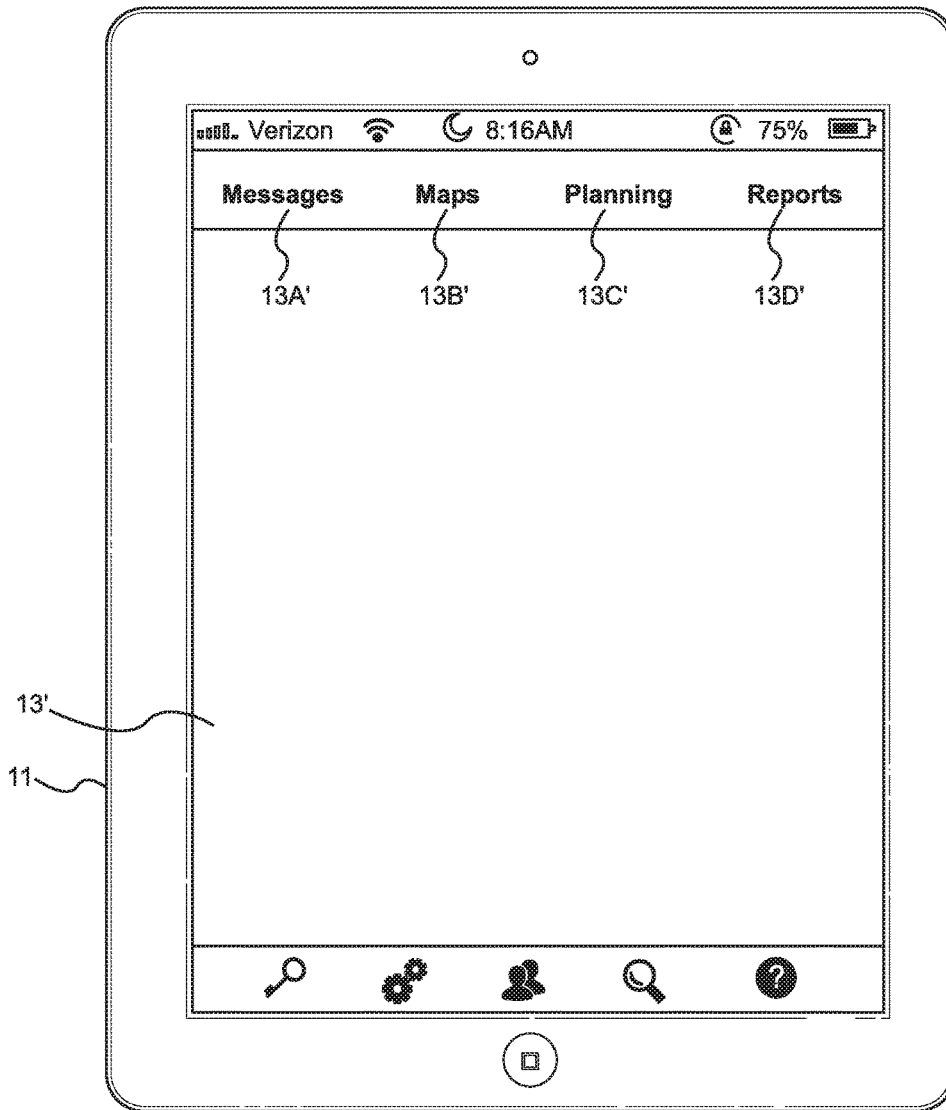

FIG. 13

GRAPHICAL USER INTERFACE SUPPORTED BY THE MOBILE APPLICATION FOR USE BY
COMMAND CENTER ADMINISTRATORS TO ISSUE WILD-FIRE PROTECTION ORDERS

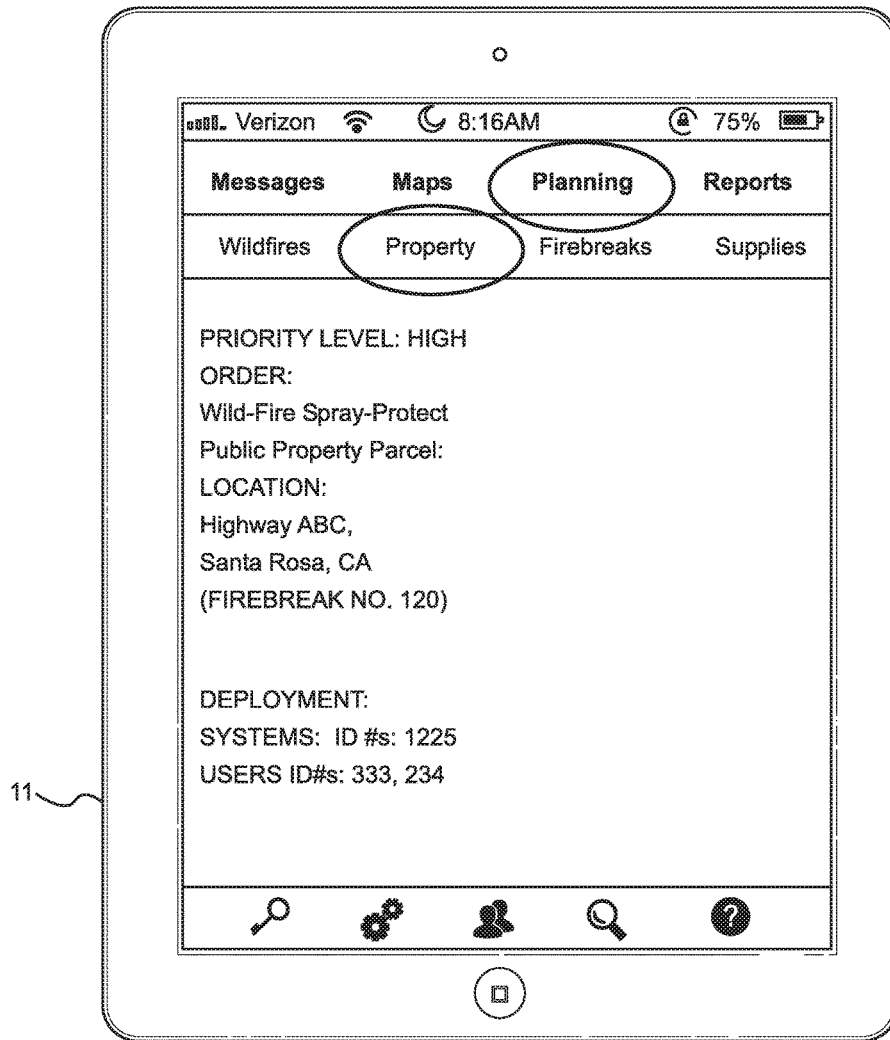

FIG. 13A

GRAPHICAL USER INTERFACE SUPPORTED BY MOBILE APPLICATION FOR USE BY COMMAND CENTER ADMINISTRATORS TO ISSUE WILD-FIRE PROTECTION ORDERS INVOLVING THE CREATION AND MAINTENANCE OF CLEAN AF-BASED CHEMICAL FIREBREAK

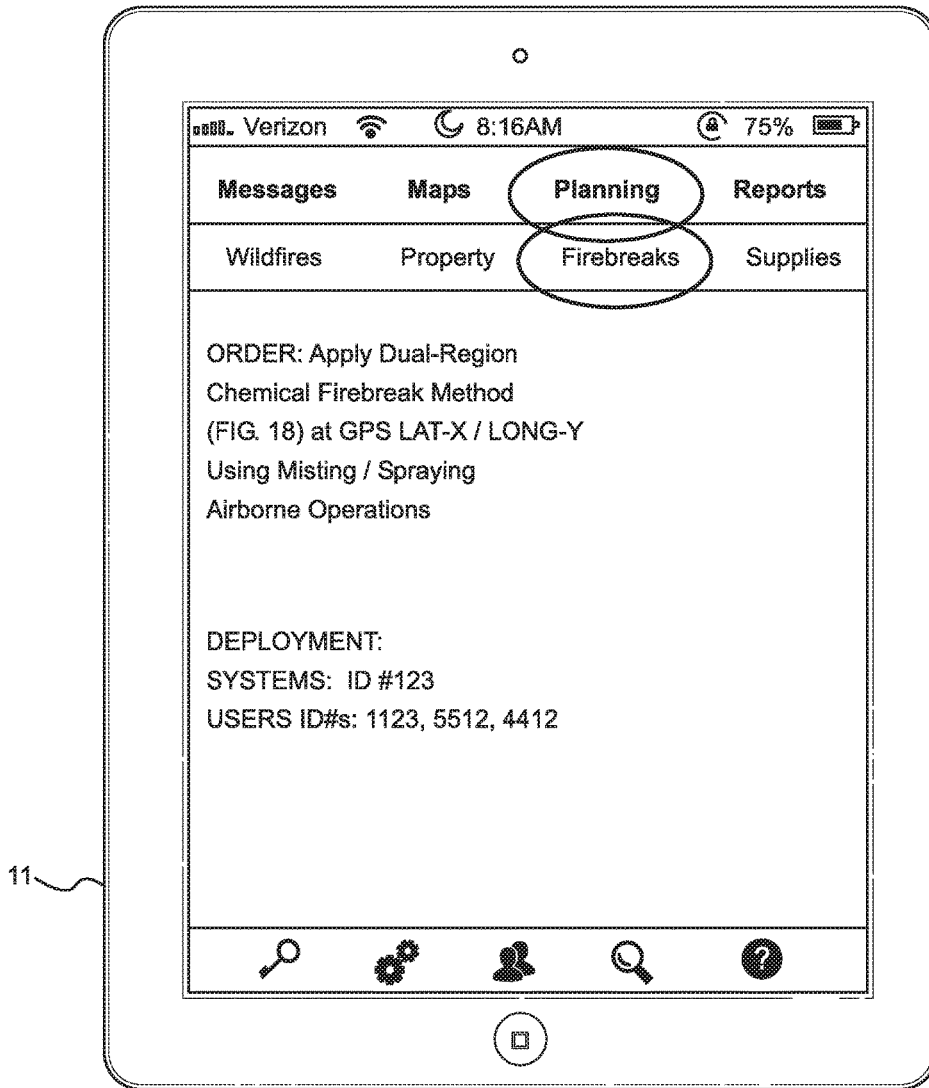

FIG. 13B

GRAPHICAL USER INTERFACE SUPPORTED BY MOBILE APPLICATION FOR USE BY COMMAND CENTER ADMINISTRATORS TO ORDER THE CREATION OF GPS-SPECIFIED CLEAN AF-BASEDCHEMICAL FIREBREAKS ON ONE OR MORE PUBLIC / PRIVATE PROPERTY PARCELS

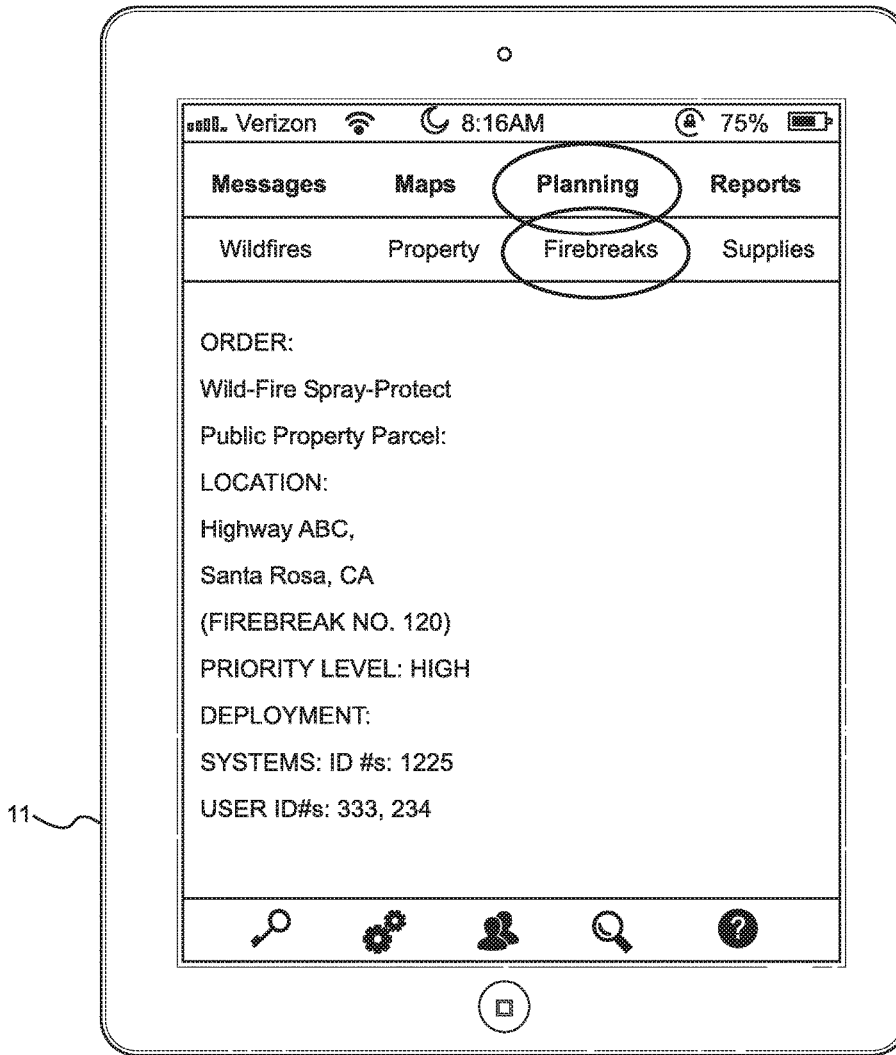

FIG. 13C

GRAPHICAL USER INTERFACE FOR MOBILE APPLICATION USED BY COMMAND CENTER ADMINISTRATORS TO RECEIVE MESSAGES FROM USERS INCLUDING PROPERTY OWNERS AND CONTRACTORS REQUESTING REFILLS FOR CLEAN ANTI-FIRE (AF) CHEMICAL LIQUID

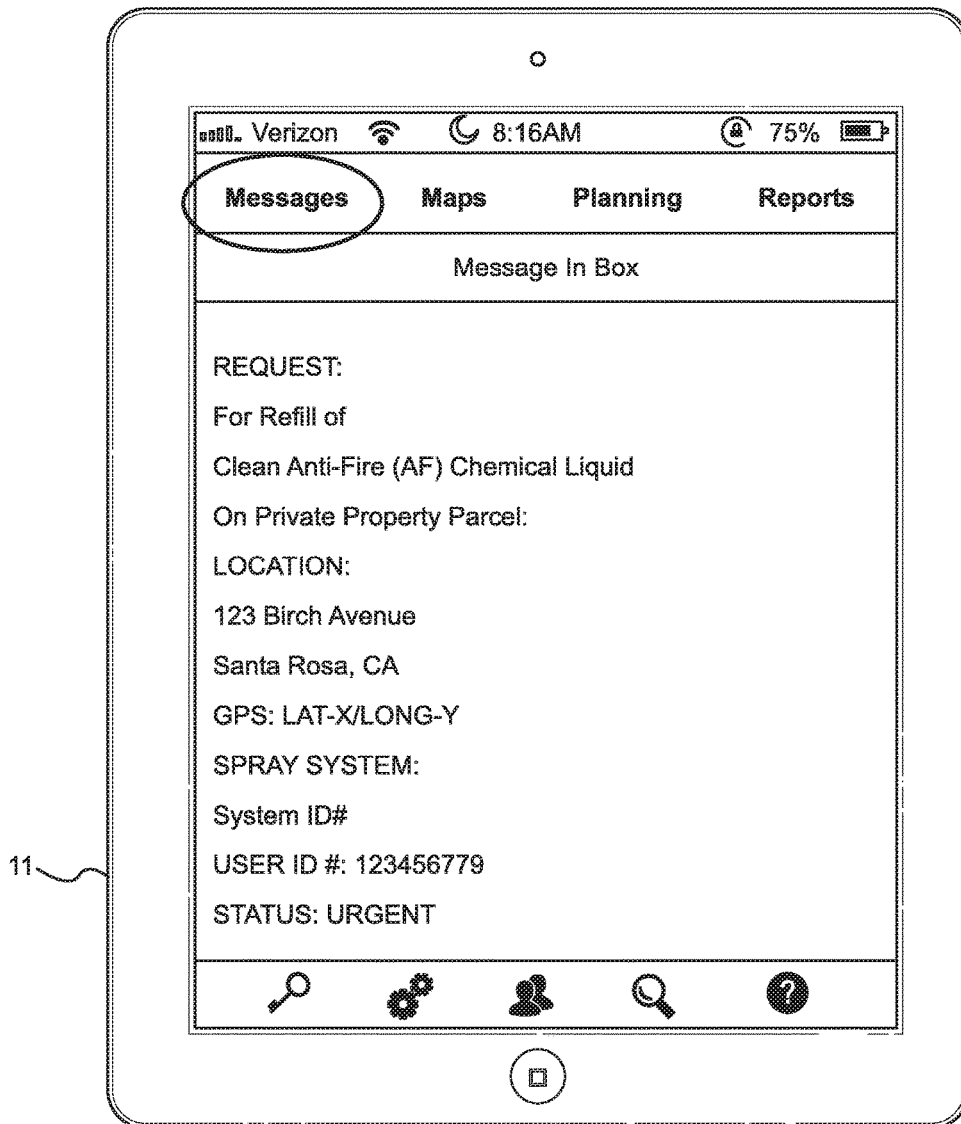

FIG. 13D

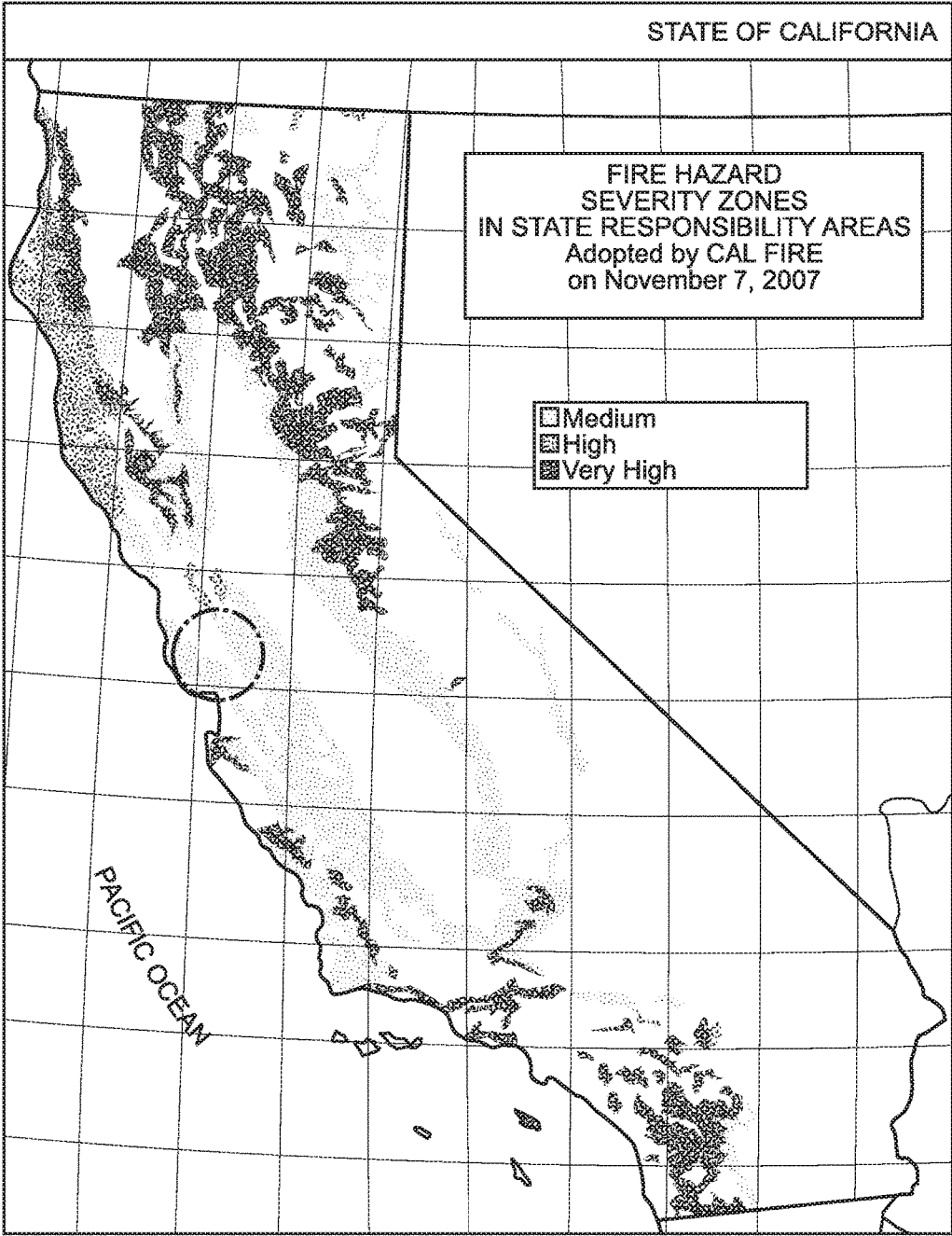

FIG. 14

EXEMPLARY ANTI-FIRE SPRAY PROTECTION MAP GENERATED BY THE SYSTEM NETWORK
SHOWING HOUSES AND STRUCTURES SPRAYED AND NOT-SPRAYED WITH ANTI-FIRE (AF) LIQUID
AS OF RECORD DATE 15 DECEMBER 2017

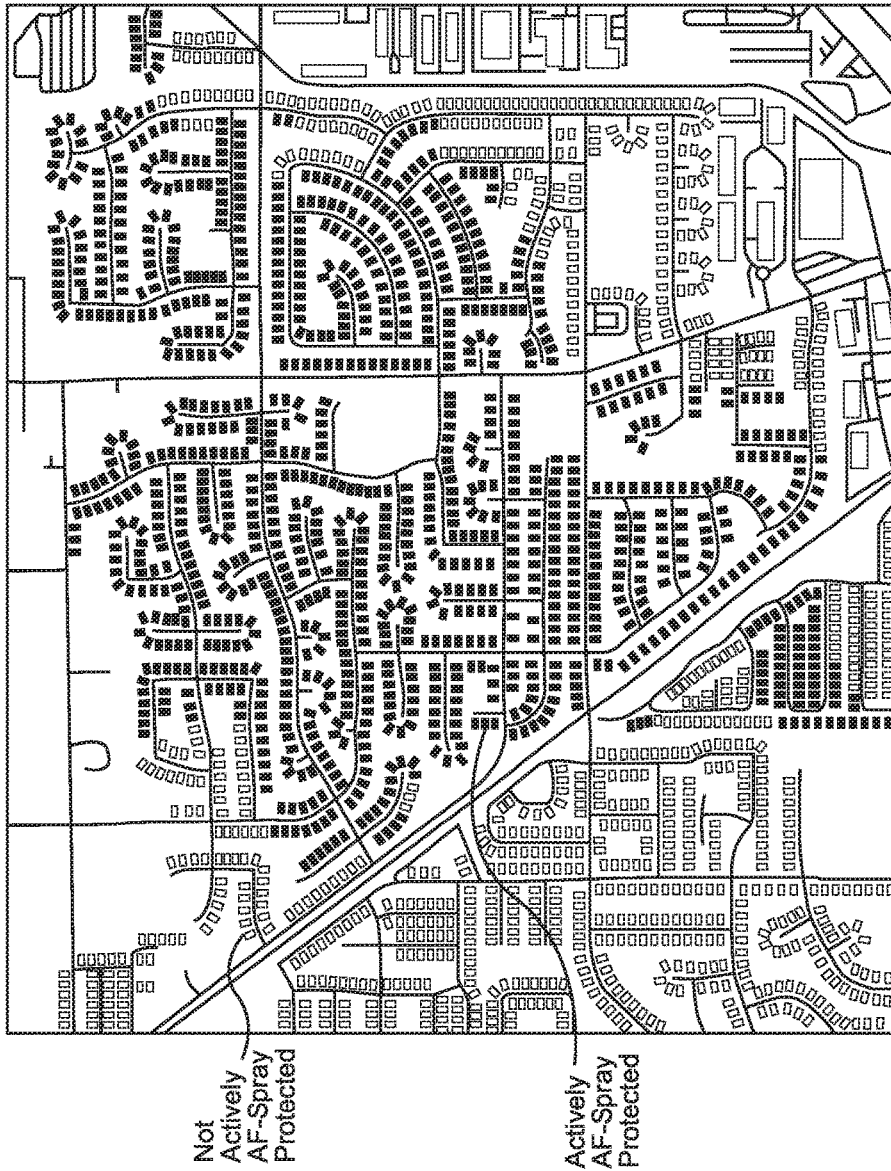

FIG. 15

EXEMPLARY ANTI-FIRE (AF) SPRAY PROTECTION TASK REPORT
GENERATED BY THE SYSTEM FOR COUNTY, STATE ON 15 DECEMBER 2017

AF Liquid Spray Order #	GPS Addresses	Street Addresses, Town, County	Building Structure (Y/N)	Last Appln. Date	Spray Equip.	SMS	Supervisor ID

FIG. 16

PLAN VIEW OF A WILD FIRE APPROACHING A NEIGHBORING TOWN
IN THE DIRECTION OF PREVAILING WINDS

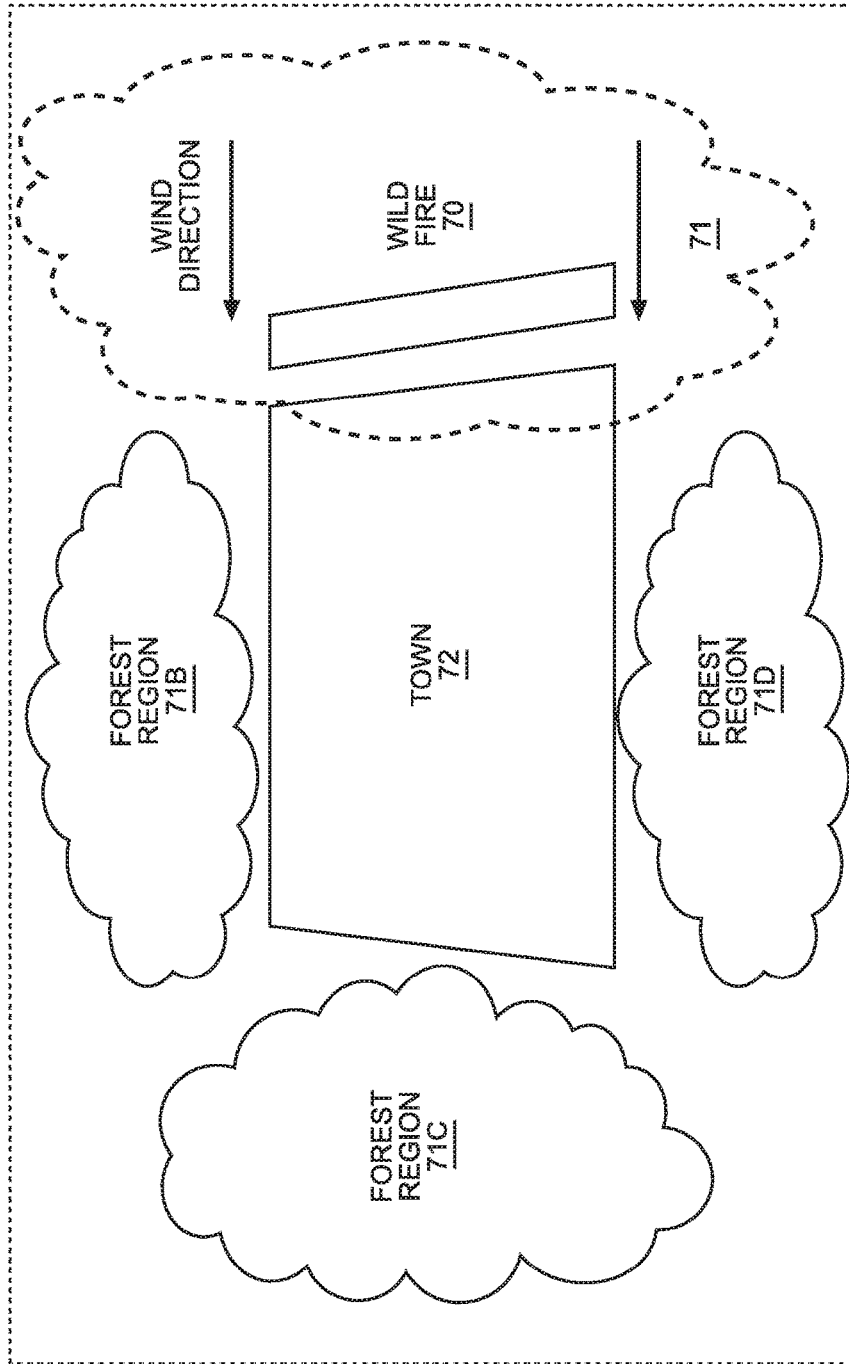

FIG. 17

METHOD OF SUPPRESSING A WILD FIRE RAGING ACROSS A REGION OF LAND BY FORMING A MULTI-STAGE ANTI-FIRE CHEMICAL FIRE-BREAK SYSTEM USING THE REMOTELY MANAGED GPS-CONTROLLED APPLICATION OF ANTI-FIRE (AF) LIQUID MIST AND SPRAY STREAMS FROM GROUND AND AIR BASED GPS-TRACKED ANTI-FIRE (AF) LIQUID SPRAY VEHICLES

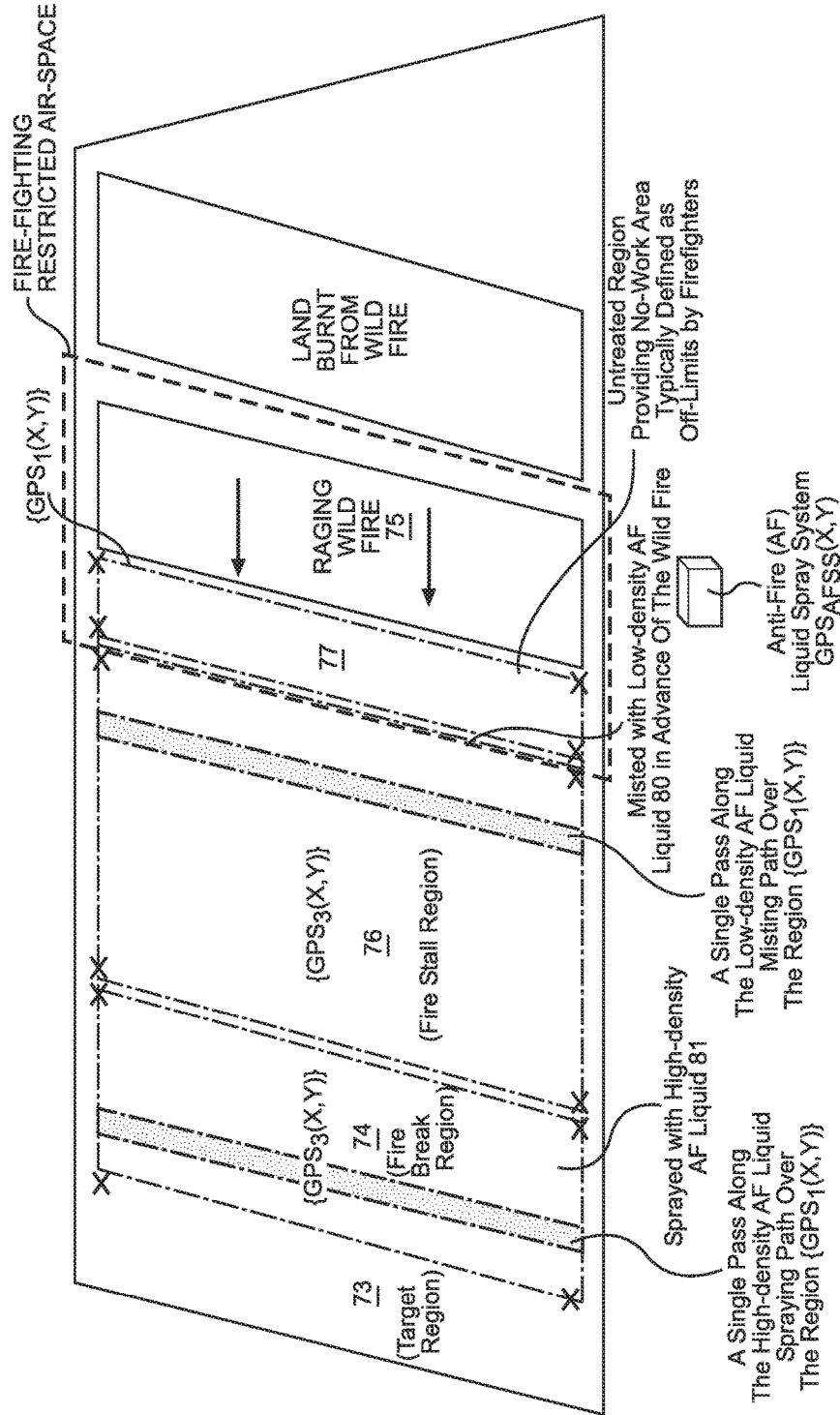

FIG. 18

METHOD OF SUPPRESSING A WILD FIRE RAGING TOWARDS A TARGET REGION OF LAND IN A DIRECTION DETERMINED BY PREVAILING WINDS AND OTHER ENVIRONMENTAL AND WEATHER FACTORS

A: PRIOR TO THE WILD FIRE REACHING THE SPECIFIED TARGET REGION OF LAND, APPLYING A LOW-DENSITY ANTI-FIRE (AF) LIQUID MIST IN ADVANCE OF THE WILD FIRE SO AS TO FORM A FIRE STALL REGION WHILE PROVIDING A NON-TREATED REGION OF SUFFICIENT SIZE BETWEEN THE FRONT OF THE WILD FIRE APPROACHING THE TARGET REGION OF LAND AND THE FIRE STALL REGION, WHEREIN SAID NON-TREATED REGION IS DEFINED BY A FIRST SET OF GPS COORDINATES (GPS1(X,Y)); MAPPED OUT USING GLOBAL POSITIONING SYSTEM (GPS) METHODS, WHEREIN SAID FIRE STALL REGION IS DEFINED BY A SECOND SET OF GPS COORDINATES (GPS2(X,Y)); MAPPED OUT USING GLOBAL POSITIONING SYSTEM (GPS) METHODS, AND WHEREIN SAID FIRE STALL REGION IS FORMED BY A FIRST GPS-GUIDED AIRCRAFT FLYING OVER SAID FIRE STALL REGION DURING MULTIPLE PASSES, AND APPLYING SAID LOW-DENSITY AF LIQUID MIST OVER SAID FIRE STALL REGION;

B: APPLYING A HIGH-DENSITY ANTI-FIRE (AF) LIQUID SPRAY IN ADVANCE OF THE WILD FIRE TO FORM A FIRE BREAK REGION BEYOND AND CONTIGUOUS WITH SAID FIRE STALL REGION, WHEREIN SAID FIRE BREAK REGION IS DEFINED BY A THIRD SET OF GPS COORDINATES (GPS3(X,Y)); MAPPED OUT USING GLOBAL POSITIONING SYSTEM (GPS) METHODS, AND WHEREIN SAID FIRE BREAK REGION IS FORMED BY A SECOND GPS-GUIDED AIRCRAFT FLYING OVER SAID FIRE BREAK REGION DURING MULTIPLE PASSES AND APPLYING SAID HIGH-DENSITY AF LIQUID SPRAY OVER SAID FIRE BREAK REGION; AND



FIG. 19A

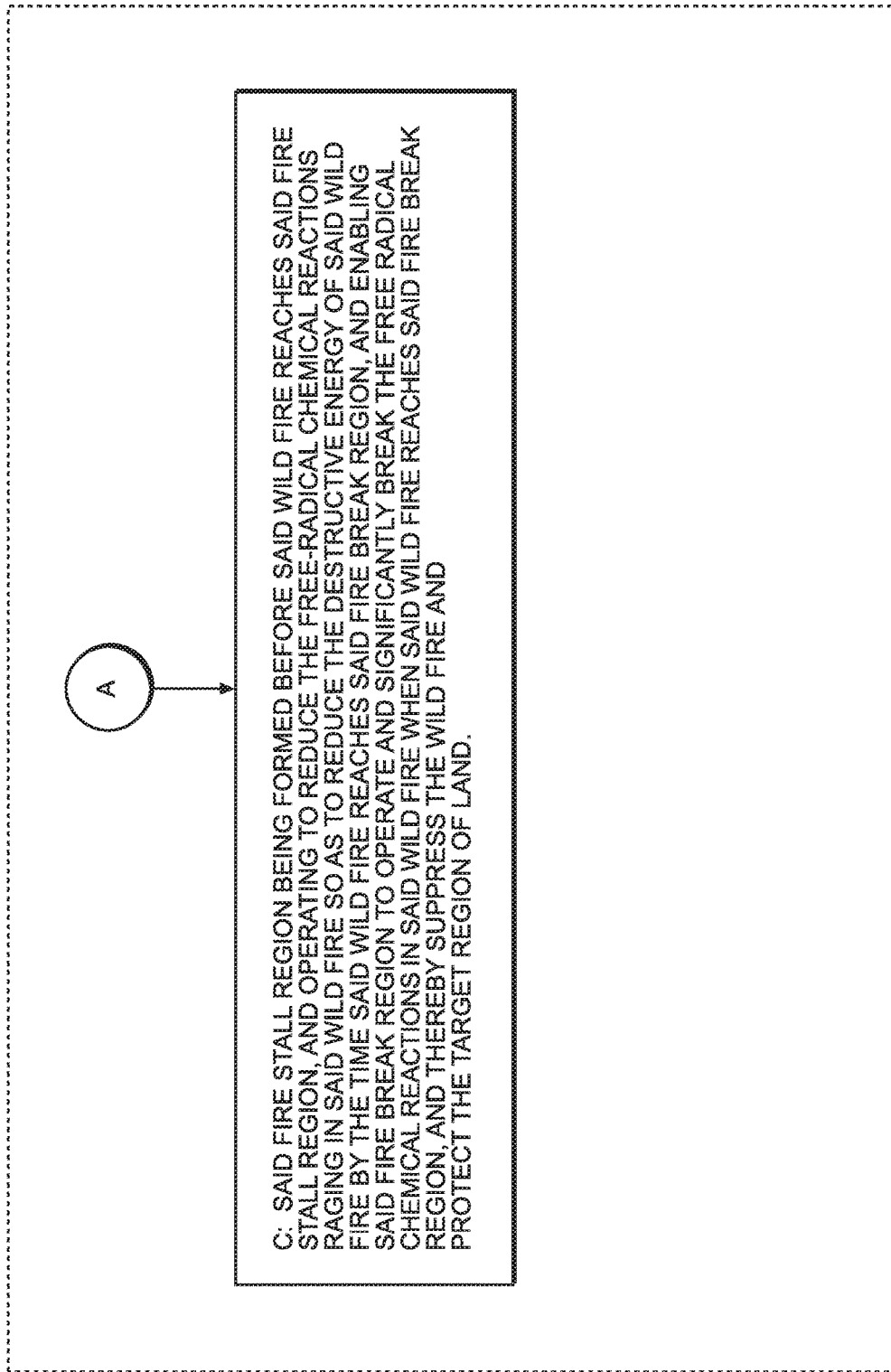

FIG. 19B

**METHOD OF REDUCING THE RISKS OF DAMAGE TO PRIVATE PROPERTY DUE TO WILD FIRES
BY REMOTELY MANAGED GPS-CONTROLLED APPLICATION OF ANTI-FIRE (AF) LIQUID SPRAY
FROM GROUND AND AIR BASED GPS-TRACKED ANTI-FIRE (AF) LIQUID SPRAY VEHICLES**

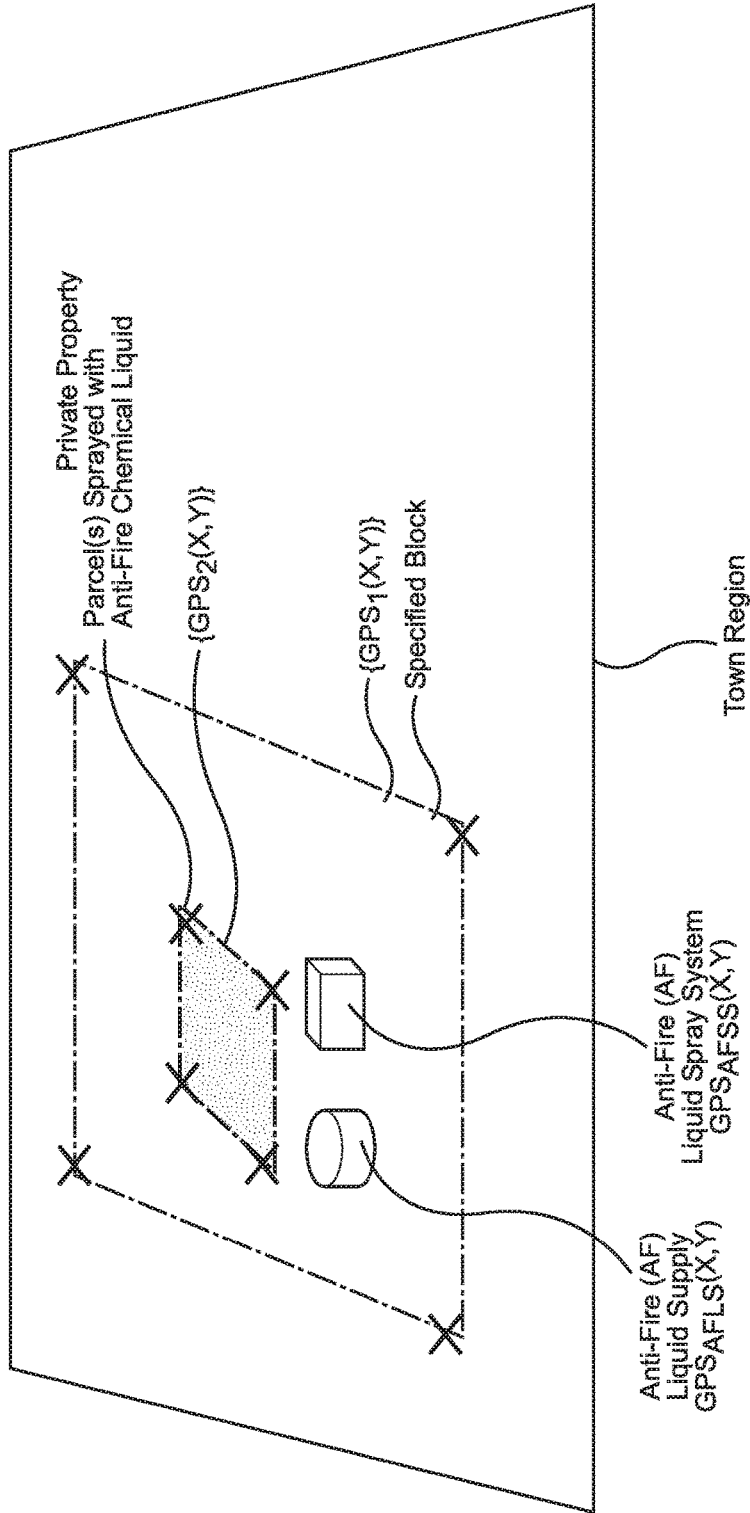

FIG. 20

METHOD OF REDUCING THE RISKS OF DAMAGE TO PRIVATE PROPERTY DUE TO WILD FIRES BY REMOTELY MANAGED GPS-CONTROLLED APPLICATION OF ANTI-FIRE (AF) LIQUID SPRAY

A: REGISTERING IN A NETWORK DATABASE, EACH GPS-SPECIFIED PARCEL OF PRIVATE REAL PROPERTY IN A SPECIFIED COUNTY AND STATE, WHICH MAY OR MAY NOT HAVE BUILDINGS CONSTRUCTED THEREON, AND IDENTIFYING THE OWNER AND TENANTS, AS WELL AS ALL PETS, VEHICLES AND WATER CRAFTS ASSOCIATED WITH THE REGISTERED PARCEL OF PRIVATE PROPERTY.

B: COLLECTING INTELLIGENCE RELATING TO THE COUNTY, RISKS OF WILD FIRES IN THE SURROUNDING REGION, AND HISTORICAL DATA MAINTAINED IN THE NETWORK DATABASE, AND GENERATING GPS-SPECIFIED ANTI-FIRE (AF) SPRAY PROTECTION MAPS AND TASK REPORTS.

C: PROVIDING AN AF LIQUID SPRAY SYSTEM TO A GPS-SPECIFIED LOCATION FOR SPRAYING ONE OR MORE GPS-SPECIFIED PARCELS OF PRIVATE PROPERTY WITH AF CHEMICAL LIQUID SPRAY.

D: PROVIDING A SUPPLY OF AF CHEMICAL LIQUID SPRAY TO THE REGISTERED GPS-SPECIFIED LOCATION OF THE AF LIQUID SPRAY SYSTEM

E: FILLING THE AF LIQUID SPRAY SYSTEM WITH THE PROVIDED SUPPLY OF AF CHEMICAL LIQUID

FIG. 21A

F: BASED ON THE GPS-SPECIFIED ANTI-FIRE (AF) SPRAY PROTECTION MAPS AND TASK REPORTS THE SYSTEM ISSUING ORDERS TO THE PRIVATE PROPERTY OWNER OVER AN ELECTRONIC MESSAGING SYSTEM, TO APPLY AF CHEMICAL LIQUID SPRAY ON THE PRIVATE PROPERTY USING THE AF LIQUID SPRAY SYSTEM PRIOR TO THE PRESENCE OF WILD FIRE IN THE REGION.

G: THE PRIVATE PROPERTY OWNER EXECUTING THE ORDER AND APPLYING AF CHEMICAL LIQUID SPRAY ON THE PRIVATE PROPERTY USING THE AF LIQUID SPRAY SYSTEM, AND THE SYSTEM REMOTELY MONITORING THE CONSUMPTION AND APPLICATION OF AF CHEMICAL LIQUID AT THE PRIVATE PROPERTY ON A GIVEN DATE AND DATE AND AUTOMATICALLY RECORDING THE TRANSACTION IN THE NETWORK DATABASE.

H: THE SYSTEM UPDATING RECORDS IN THE NETWORK DATABASE ASSOCIATED WITH EACH APPLICATION OF AF CHEMICAL LIQUID SPRAY ON A REGISTERED PARCEL OF PRIVATE PROPERTY.

I: THE SYSTEM SCHEDULING THE NEXT APPLICATION OF AF CHEMICAL LIQUID SPRAY ON THE PARCELS OF PRIVATE PROPERTY, FACTORING WEATHER CONDITIONS, WEAR AND TIME.

J: THE SYSTEM ISSUING ANOTHER ORDER TO THE GPS-SPECIFIED PARCELS OF PRIVATE PROPERTY TO RE-APPLY AF CHEMICAL LIQUID SPRAY THEREON TO MAINTAIN ACTIVE FIRE PROTECTION.

FIG. 21B

K: THE PROPERTY OWNER EXECUTING THE ORDER TO REAPPLY AF CHEMICAL LIQUID SPRAY ON THE PARCELS OF PRIVATE PROPERTY USING THE AF LIQUID SPRAY SYSTEM, AND THE SYSTEM REMOTELY MONITORING THE APPLICATION OF AF CHEMICAL LIQUID AT THE PRIVATE PROPERTY ON A GIVEN TIME AND DATE, AND RECORDING THIS TRANSACTION IN THE NETWORK DATABASE.

L: THE SYSTEM UPDATING RECORDS ON AF CHEMICAL LIQUID SPRAY APPLICATION IN THE NETWORK DATABASE, CONCERNING REAPPLICATION OF AF CHEMICAL LIQUID ON THE PARCELS OF PRIVATE PROPERTY.

M: THE SYSTEM SCHEDULING THE NEXT APPLICATION OF AF LIQUID SPRAY ON THE PARCELS OF PRIVATE PROPERTY, FACTORING WEATHER CONDITIONS AND THE PASSAGE OF TIME, AND UPDATING THE NETWORK DATABASE.

FIG. 21C

**METHOD OF REDUCING THE RISKS OF DAMAGE TO PUBLIC PROPERTY DUE TO WILD FIRES
BY GPS-CONTROLLED APPLICATION OF ANTI-FIRE (AF) LIQUID SPRAY
FROM GROUND AND AIR BASED GPS-TRACKED ANTI-FIRE (AF) LIQUID SPRAY VEHICLES**

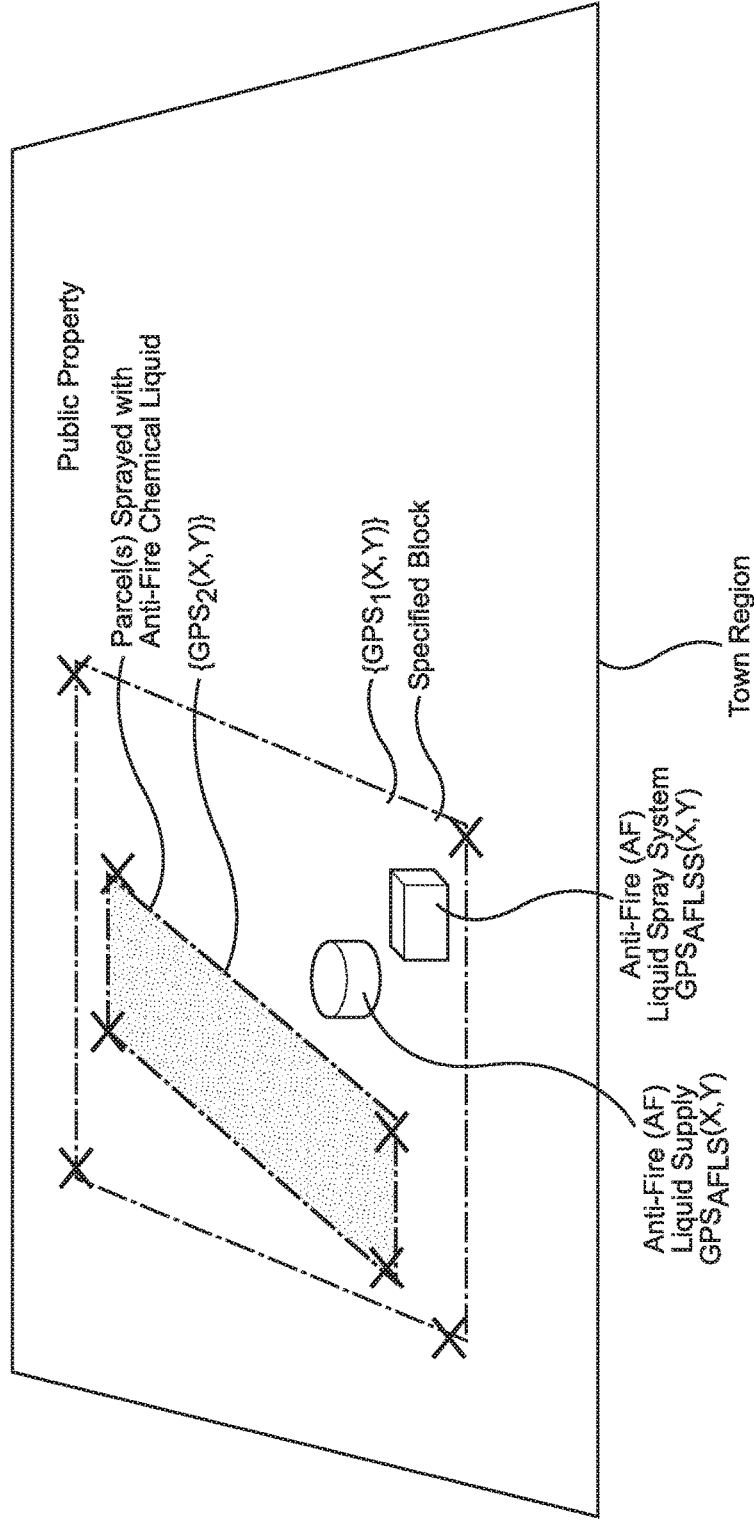

FIG. 22

METHOD OF REDUCING THE RISKS OF DAMAGE TO PUBLIC PROPERTY DUE TO WILD FIRES
BY GPS-CONTROLLED APPLICATION OF ANTI-FIRE (AF) LIQUID SPRAY

A: REGISTERING WITH A NETWORK DATABASE, EACH GPS-SPECIFIED PARCEL OF PUBLIC REAL PROPERTY IN A SPECIFIED COUNTY AND STATE, WHICH MAY OR MAY NOT HAVE BUILDINGS CONSTRUCTED THEREON, AND IDENTIFYING THE OWNER AND TENANTS, ALL PETS, VEHICLES AND WATERCRAFTS ASSOCIATED WITH THE REGISTERED PARCEL OF PUBLIC PROPERTY.

B: COLLECTING INTELLIGENCE RELATING TO THE COUNTY RISKS OF WILD FIRES IN THE SURROUNDING REGION, AND HISTORICAL DATA MAINTAINED IN THE NETWORK DATABASE, AND GENERATING ANTI-FIRE (AF) SPRAY PROTECTION MAPS AND TASK REPORTS FOR EXECUTION

C: PROVIDING AN AF LIQUID SPRAY SYSTEM TO A GPS-SPECIFIED LOCATION FOR SPRAYING ONE OR MORE GPS-SPECIFIED PARCELS OF PUBLIC PROPERTY WITH AF CHEMICAL LIQUID SPRAY.

D: PROVIDING A SUPPLY OF AF LIQUID SPRAY TO THE GPS-SPECIFIED LOCATION OF THE AF LIQUID SPRAY SYSTEM

E: FILLING THE AF LIQUID SPRAY SYSTEM WITH THE PROVIDED SUPPLY OF AF LIQUID

FIG. 23A

F: BASED ON GPS-SPECIFIED ANTI-FIRE (AF) SPRAY PROTECTION MAPS AND TASK REPORTS, THE SYSTEM ISSUING ORDERS TO THE PUBLIC PROPERTY OWNER, OR ITS CONTRACTOR, TO APPLY AF LIQUID SPRAY ON THE PROPERTY PARCELS USING THE AF LIQUID SPRAY SYSTEM.

G: THE PUBLIC PROPERTY OWNER EXECUTING THE ORDER AND APPLYING AF CHEMICAL LIQUID SPRAY ON THE PUBLIC PROPERTY USING THE AF LIQUID SPRAY SYSTEM, AND THE SYSTEM REMOTELY MONITORING THE CONSUMPTION AND APPLICATION OF AF CHEMICAL LIQUID AT THE PUBLIC PROPERTY ON A GIVEN DATE AND TIME, AND AUTOMATICALLY RECORDING THE TRANSACTION IN THE NETWORK DATABASE.

H: THE SYSTEM UPDATING RECORDS IN THE NETWORK DATABASE ASSOCIATED WITH EACH APPLICATION OF AF CHEMICAL LIQUID SPRAY ON GPS-SPECIFIED PARCELS OF PUBLIC PROPERTY.

I: THE SYSTEM SCHEDULING THE NEXT APPLICATION OF AF LIQUID SPRAY ON THE PARCELS OF PUBLIC PROPERTY, FACTORING WEATHER CONDITIONS AND THE PASSAGE OF TIME.

J: THE SYSTEM ISSUING ANOTHER ORDER TO THE GPS-SPECIFIED PARCELS OF PUBLIC PROPERTY TO RE-APPLY AF LIQUID SPRAY THEREON TO MAINTAIN ACTIVE FIRE PROTECTION.

FIG. 23B

K: THE PROPERTY OWNER EXECUTING THE ORDER TO REAPPLY AF LIQUID SPRAY ON THE PARCELS OF PUBLIC PROPERTY USING THE AF LIQUID SPRAY SYSTEM, AND THE SYSTEM REMOTELY MONITORING THE APPLICATION OF AF CHEMICAL LIQUID AT THE PUBLIC PROPERTY ON A GIVEN TIME AND DATE, AND RECORDING THIS TRANSACTION IN THE NETWORK DATABASE.

L: THE SYSTEM UPDATING RECORDS ON AF LIQUID SPRAY APPLICATION IN THE NETWORK DATABASE ASSOCIATED WITH REAPPLICATION OF AF LIQUID ON PARCELS OF PUBLIC PROPERTY

M: THE SYSTEM SCHEDULING THE NEXT APPLICATION OF AF LIQUID SPRAY ON THE PARCELS OF PUBLIC PROPERTY, FACTORING WEATHER CONDITIONS AND THE PASSAGE OF TIME.

FIG. 23C

**METHOD OF REDUCING THE RISKS OF DAMAGE TO REAL PROPERTY PARCELS
DUE TO WILD FIRES BY GPS-CONTROLLED MANAGED APPLICATION OF ANTI-FIRE (AF) LIQUID
SPRAY FROM GROUND AND AIR BASED GPS-TRACKED ANTI-FIRE (AF) LIQUID SPRAY VEHICLES**

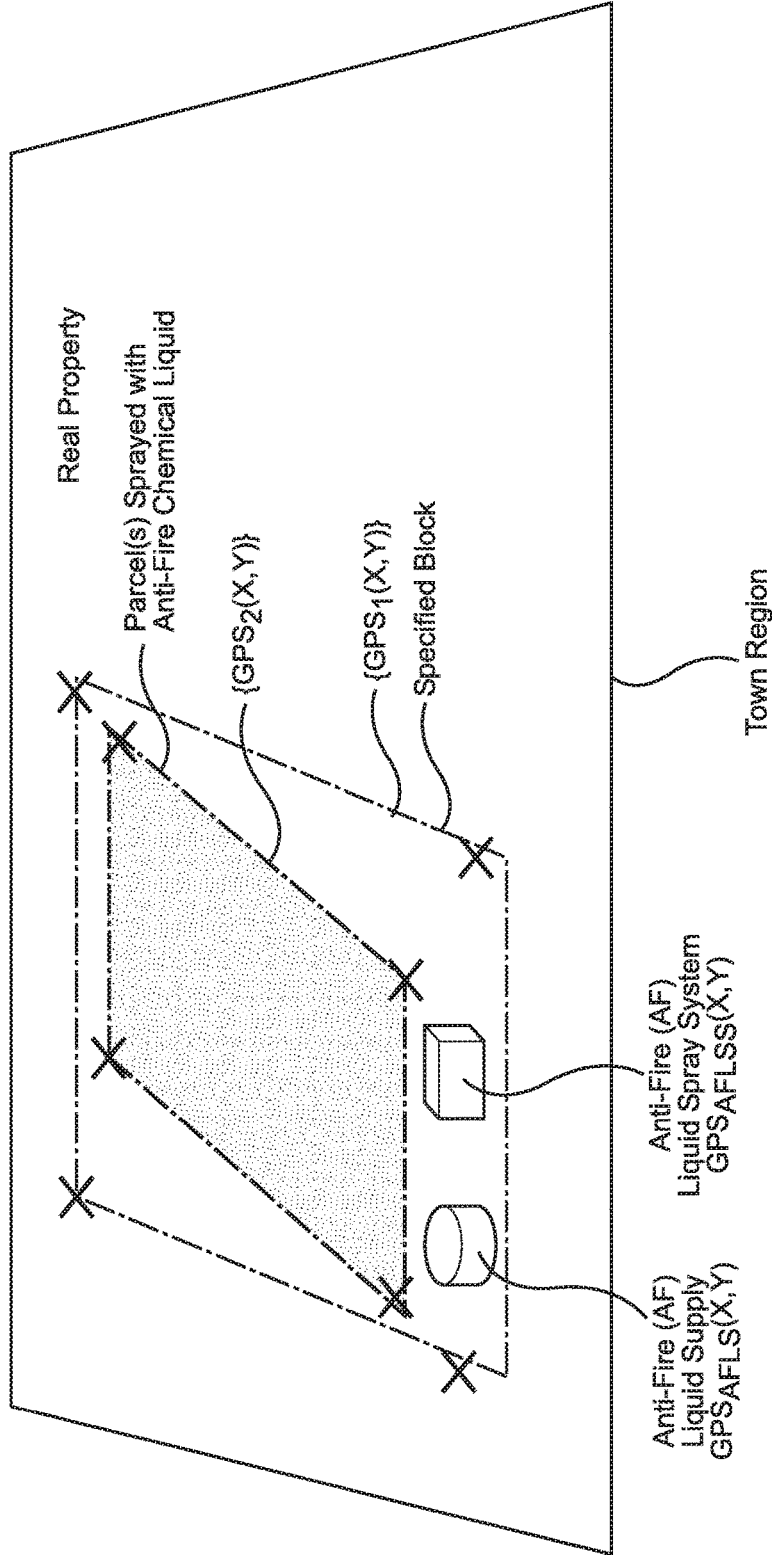

FIG. 24

METHOD OF REMOTELY MANAGING THE GPS-CONTROLLED APPLICATION OF ANTI-FIRE (AF) LIQUID SPRAY TO GROUND COVER AND BUILDINGS SO AS TO REDUCE THE RISKS OF DAMAGE DUE TO WILD FIRES

A: REGISTERING WITH A NETWORK DATABASE, EACH GPS-SPECIFIED PARCEL OF REAL PROPERTY IN A SPECIFIED COUNTY AND STATE, WHICH MAY OR MAY NOT HAVE BUILDINGS CONSTRUCTED THEREON, AND IDENTIFYING THE OWNER AND TENANTS, AS WELL AS ALL PETS, VEHICLES AND WATERCRAFTS ASSOCIATED WITH THE GPS-SPECIFIED PARCELS OF REAL PROPERTY.

B: COLLECTING INTELLIGENCE RELATING TO THE COUNTY, RISKS OF WILD FIRES IN THE SURROUNDING REGION, AND HISTORICAL DATA MAINTAINED IN THE NETWORK DATABASE, AND GENERATING GPS-SPECIFIED ANTI-FIRE (AF) SPRAY PROTECTION MAPS AND TASK REPORTS.

C: PROVIDING AN AF LIQUID SPRAY SYSTEM TO A GPS-SPECIFIED LOCATION FOR SPRAYING GPS-SPECIFIED PARCELS OF REAL PROPERTY WITH AF LIQUID SPRAY.

D: PROVIDING A SUPPLY OF AF CHEMICAL LIQUID SPRAY TO THE GPS-SPECIFIED LOCATION OF THE AF LIQUID SPRAY SYSTEM

E: FILLING THE AF LIQUID SPRAY SYSTEM WITH THE PROVIDED SUPPLY OF AF LIQUID

FIG. 25A

F: PRIOR TO THE ARRIVAL OF A WILD FIRE TO THE REGION, AND BASED ON THE GPS-SPECIFIED ANTI-FIRE (AF) SPRAY PROTECTION MAPS AND TASK REPORTS, THE SYSTEM ISSUING A REQUEST TO THE PROPERTY OWNER, OR REGISTERED CONTRACTOR, TO APPLY AF CHEMICAL LIQUID SPRAY ON THE GPS-SPECIFIED PARCELS OF PROPERTY USING THE AF LIQUID SPRAY SYSTEM.

G: IN RESPONSE TO THE ISSUED REQUEST, THE PROPERTY OWNER OR CONTRACTOR THEREOF APPLYING AF LIQUID SPRAY ON THE REAL PROPERTY USING THE AF LIQUID SPRAY SYSTEM, AND THE SYSTEM REMOTELY MONITORING THE CONSUMPTION AND APPLICATION OF THE AF CHEMICAL LIQUID ON THE PROPERTY ON A GIVEN DATE AND TIME, AND AUTOMATICALLY RECORDING THE TRANSACTION IN THE NETWORK DATABASE.

H: THE SYSTEM UPDATING RECORDS IN THE NETWORK DATABASE ASSOCIATED WITH EACH APPLICATION OF AF CHEMICAL LIQUID SPRAY ON A GPS-SPECIFIED PARCEL OF REAL PROPERTY.

FIG. 25B

MOBILE VEHICLE FOR MIXING AND SPRAYING CLEAN FIRE AND SMOKE INHIBITING SLURRY ON GROUND SURFACES TO CREATE FIRE BREAKS AND SMOTHER AMBERS AND ASH, AND IN OTHER APPLICATION

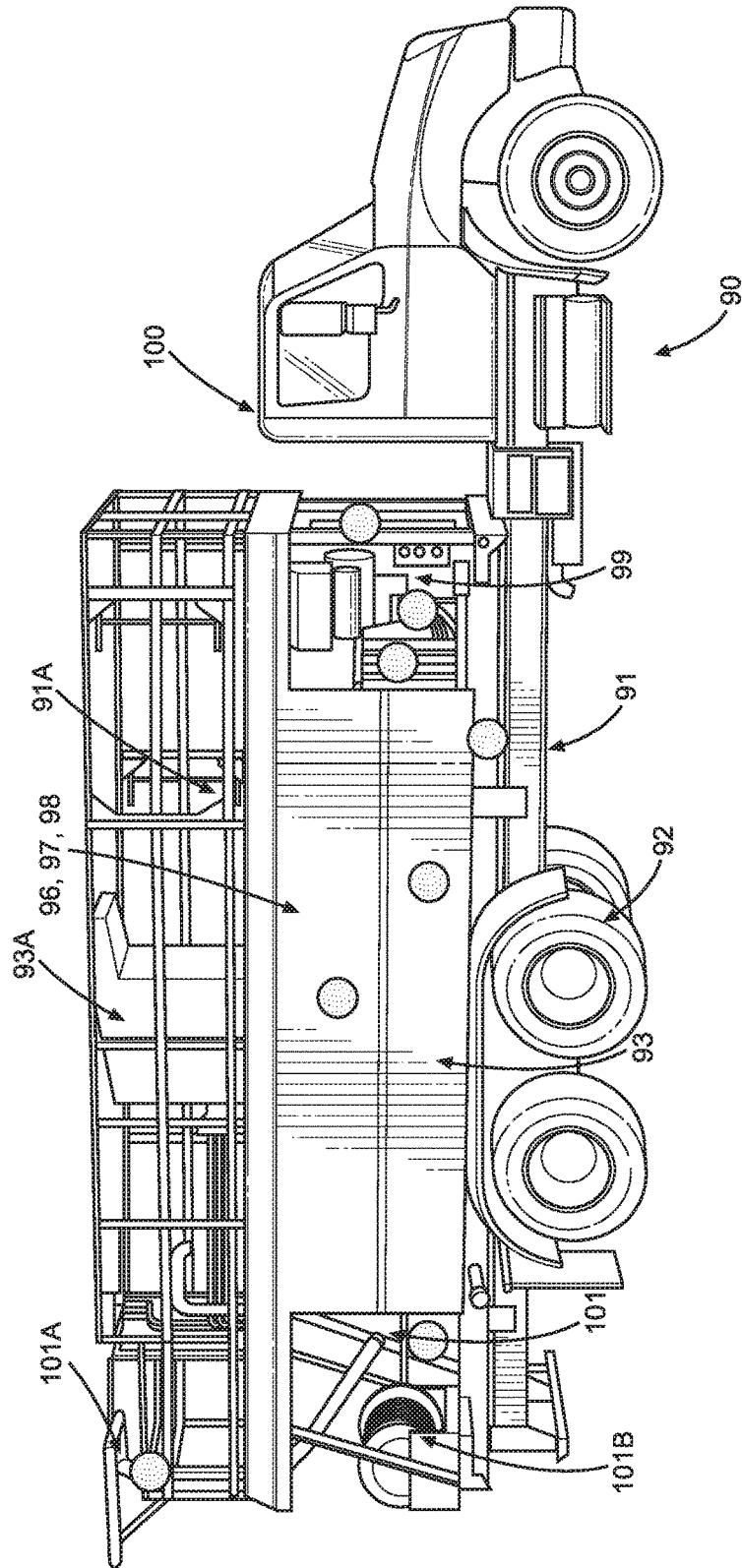

FIG. 27A

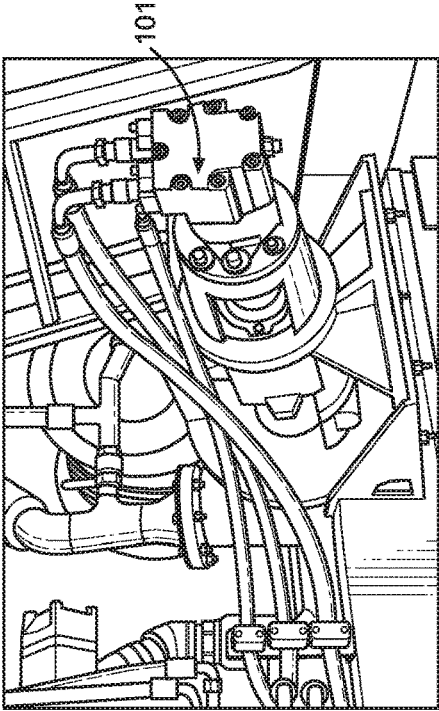

FIG. 27C

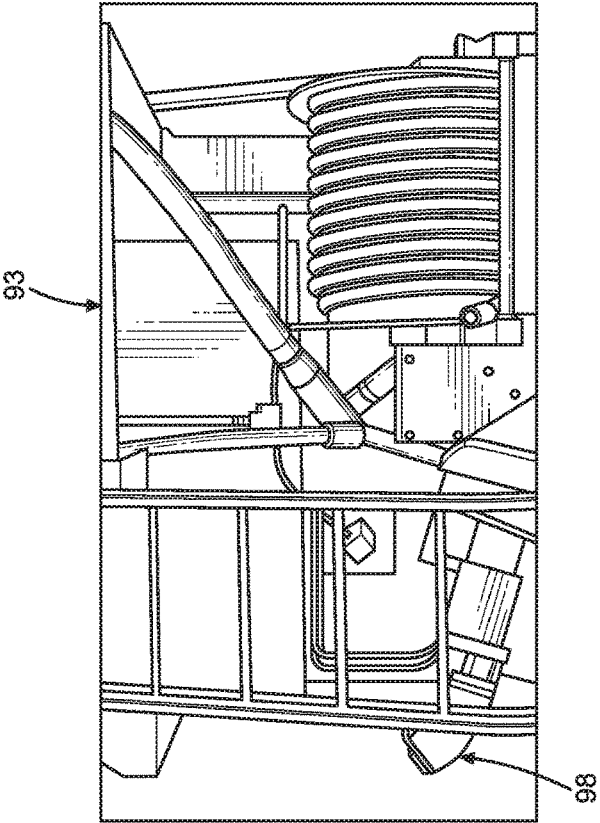

FIG. 27B

APPARATUS FOR APPLYING FIRE AND SMOKE INHIBITING COMPOSITIONS ON GROUND SURFACES BEFORE THE INCIDENCE OF WILD-FIRES, AND ALSO THEREAFTER, UPON SMOLDERING AMBERS AND ASHES TO REDUCE SMOKE AND SUPPRESS FIRE RE-IGNITION

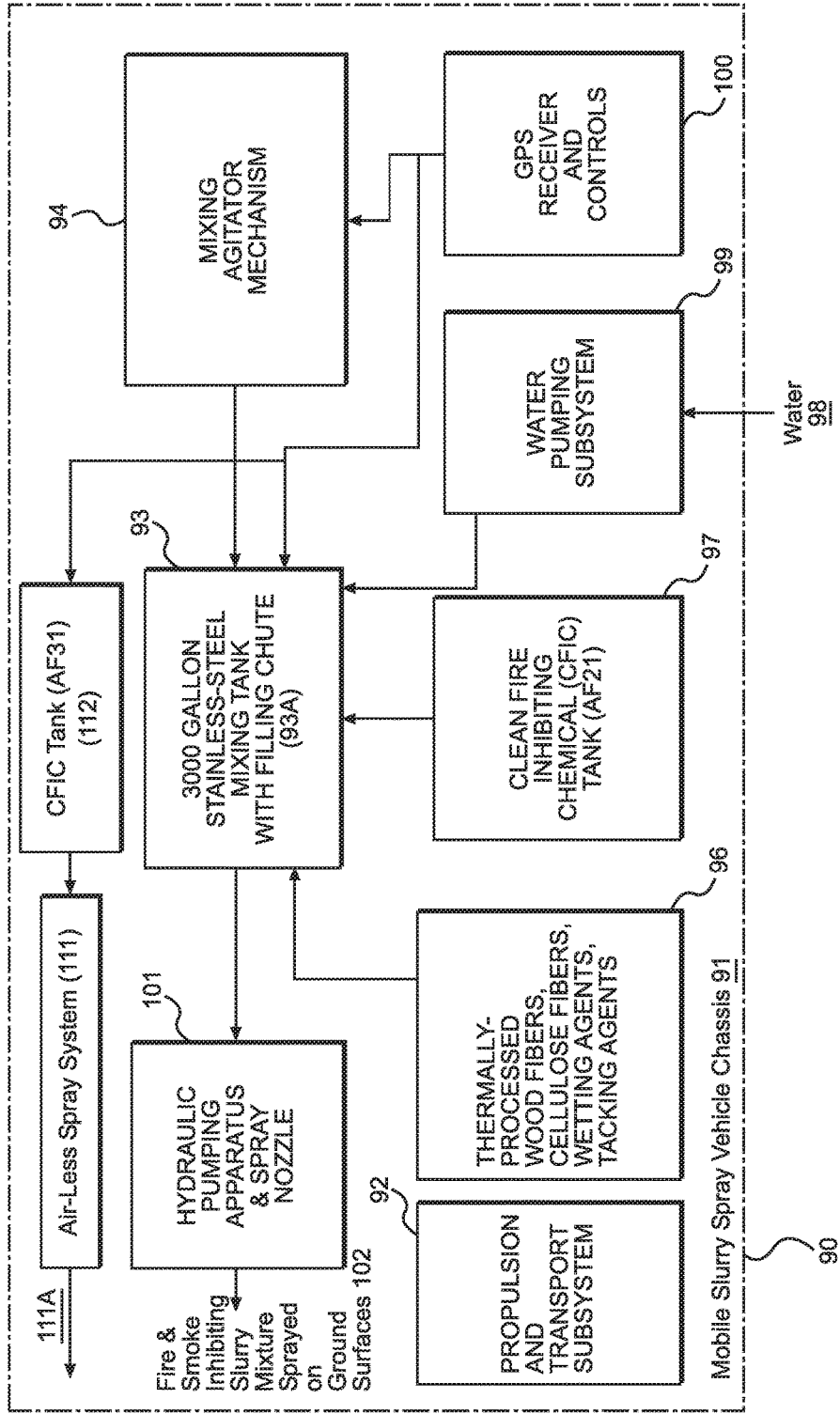

FIG. 28

METHOD OF METHOD OF APPLYING FIRE AND SMOKE INHIBITING SLURRY COMPOSITIONS ON GROUND SURFACES BEFORE THE INCIDENCE OF WILD-FIRES, AND ALSO THEREAFTER, UPON SMOLDERING AMBERS AND ASHES TO REDUCE SMOKE AND SUPPRESS FIRE RE-IGNITION

A : MEASURING AND STAKING OUT AREA USING GPS COORDINATES TO ENSURE PROPER APPLICATION

B : BLENDING PROCESSED WOOD FIBERS, CELLULOSE FIBER, WETTING AGENTS, TACKING AGENTS, AND CLEANFIRE INHIBITING CHEMICALS (CFIC), WITH A SUPPLY OF WATER TO MAKE UP A FIRE AND SMOKE INHIBITING SLURRY COMPOSITION ACCORDING TO THE PRESENT INVENTION

C : MIXING THE FIRE AND SMOKE INHIBITING SLURRY MIXTURE IN A MIXING TANK ON A MOBILE VEHICLE SUPPORTING HYDRAULIC SPRAY EQUIPMENT

D : SPRAYING THE MIXED FIRE AND SMOKE INHIBITING SLURRY MIXTURE ON THE SPECIFIC GROUND SURFACE USING HYDRAULIC SPRAY EQUIPMENT SUPPORTED ON THE MOBILE SPRAY VEHICLE

E : SPRAYING CFIC LIQUID MIST OVER THE THE APPLIED FIRE AND SMOKE INHIBITING SLURRY COATING ON THE GROUND SURFACE TO PROVIDE EROSION CONTROL, FIRE PROTECTION AND SMOKE REDUCTION IN THE PRESENT OF A WILDFIRE

FIG. 29

**A BASE HYDRAULIC MULCH LOADING CHART FOR MAKING
THE FIRE AND SMOKE INHIBITING SLURRY MIXTURE OF THE PRESENT INVENTION**

Water (gal)	Mulch Fiber (50-lb bales)	Mulch Fiber (lb)	1,500		2,000		2,500	
			Sq ft	lb/acre Acres	Sq ft	lb/acre Acres	Sq ft	lb/acre Acres
100	1	50	1,452	0.033	1,089	0.025	871	0.020
300	3	150	4,356	0.099	3,267	0.075	2,614	0.060
500	5	250	7,260	0.166	5,445	0.125	4,356	0.100
700	7	350	10,164	0.233	7,623	0.175	6,098	0.140
900	9	450	13,068	0.299	9,801	0.225	7,841	0.180
1,100	11	550	15,972	0.366	11,979	0.275	9,583	0.220
1,300	13	650	18,876	0.433	14,157	0.325	11,326	0.260
1,500	15	750	21,780	0.499	16,335	0.375	13,068	0.300
1,700	17	850	24,684	0.566	18,513	0.425	14,810	0.340
1,900	19	950	27,588	0.633	20,691	0.475	16,553	0.380
2,100	21	1,050	30,492	0.699	22,869	0.525	18,295	0.420
2,300	23	1,150	33,396	0.766	25,047	0.575	20,038	0.460
2,500	25	1,250	36,300	0.833	27,225	0.625	21,780	0.500
2,700	27	1,350	39,204	0.899	29,403	0.675	23,522	0.540
2,900	29	1,450	42,108	0.966	31,581	0.725	25,265	0.580

FIG. 30

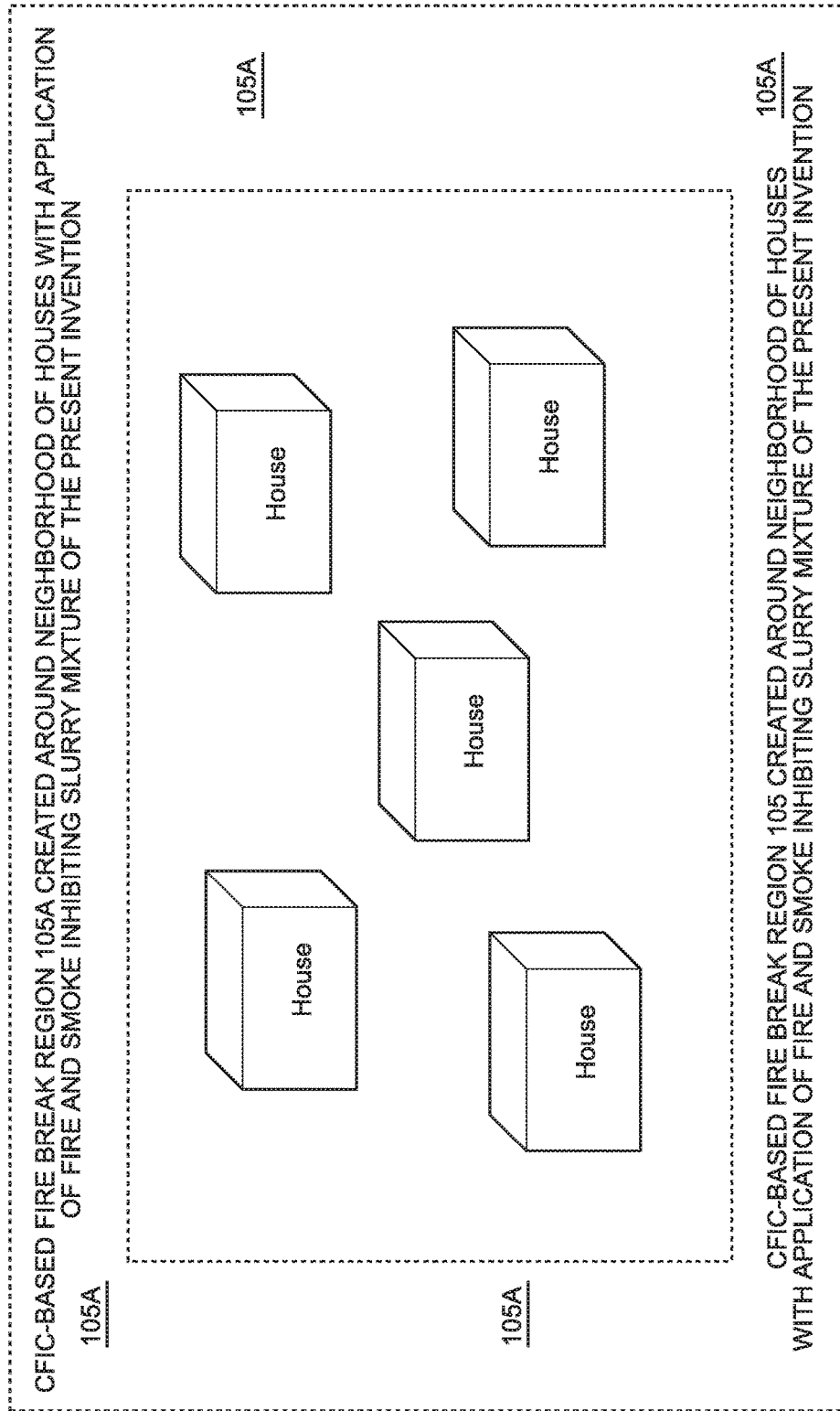

FIG. 31

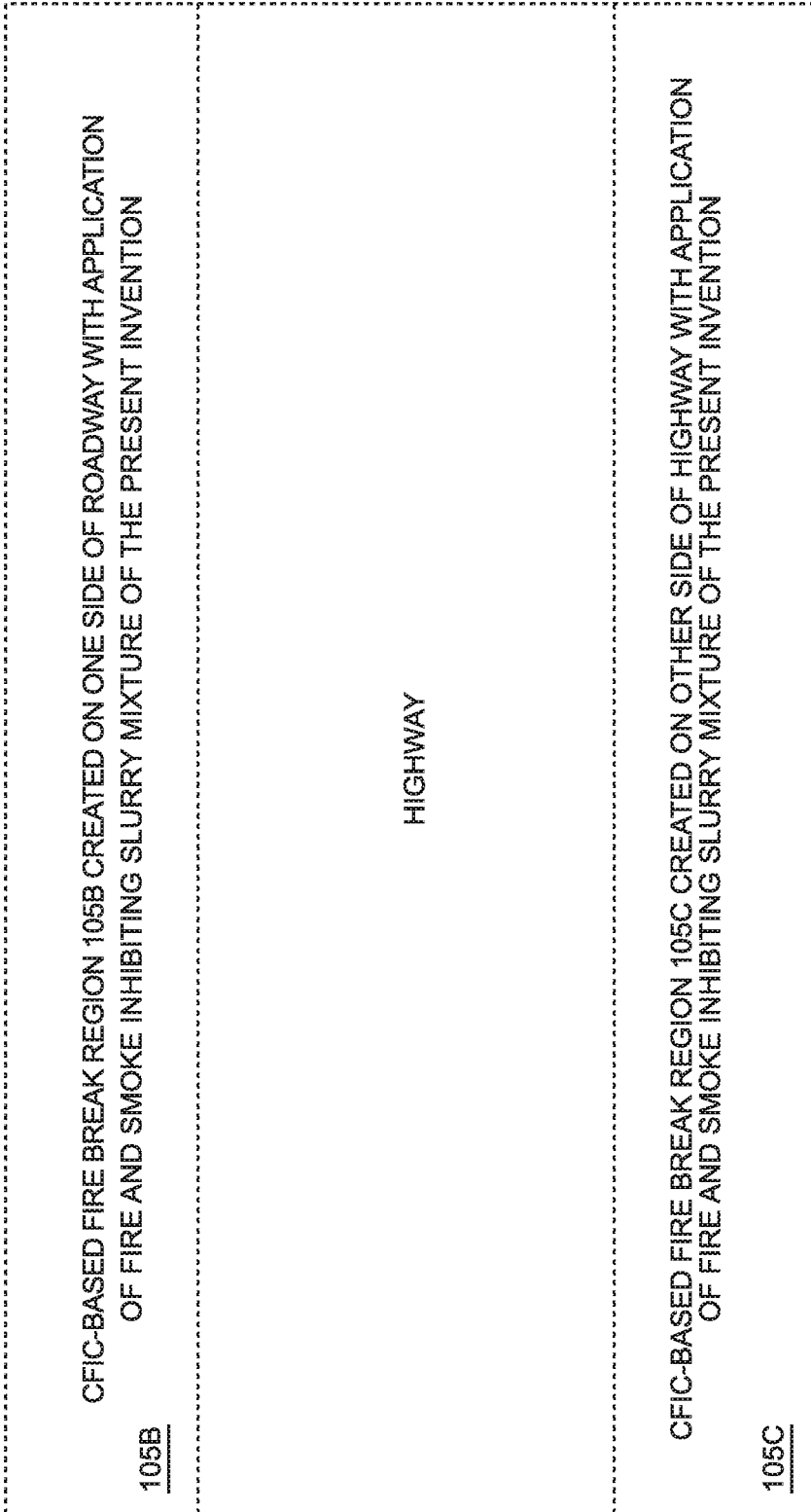
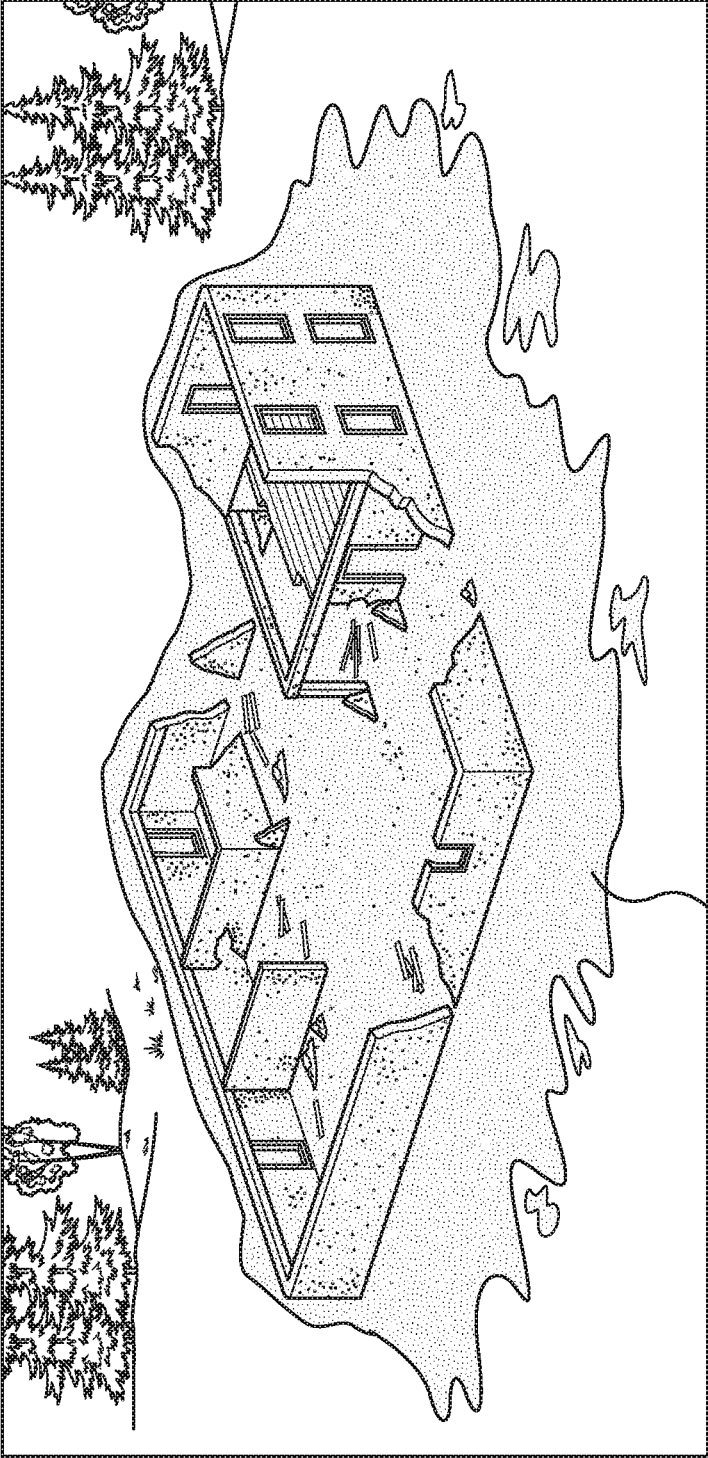

FIG. 32



FIRE & SMOKE
INHIBITING SLURRY
BLANKET (102)

FIG. 33

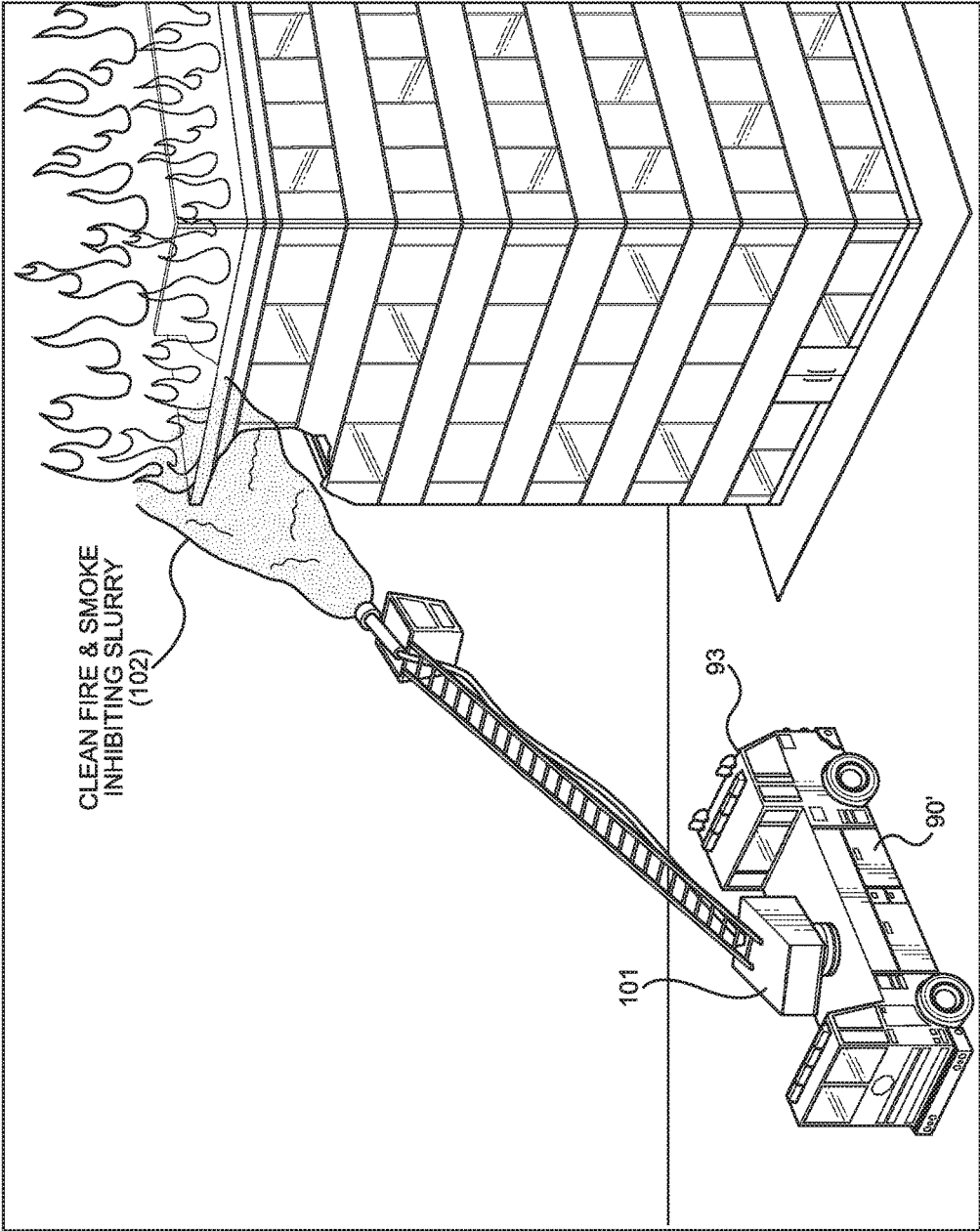

FIG. 34

METHOD OF QUALIFYING REAL PROPERTY FOR REDUCED CAUSALITY INSURANCE BASED ON VERIFIED SPRAY-BASED CLEAN ANTI-FIRE (AF) CHEMICAL LIQUID TREATMENT PRIOR TO PRESENCE OF WILD FIRES

A: PERIODICALLY SPRAYING A CLEAN ANTI-FIRE (AF) CHEMICAL LIQUID OVER THE EXTERIOR SURFACES OF A WOOD-FRAMED BUILDING AND ITS SURROUNDING REAL PROPERTY TO PROVIDE CLASS-A FIRE-PROTECTION

B: VERIFYING AND DOCUMENTING THE SPRAY-BASED CLASS-A FIRE PROTECTION TREATMENT USING SPRAY FIRE-PROTECTION TREATMENT DATA, INCLUDING GPS-COORDINATES AND TIME/DATE STAMPING DATA GENERATED BY THE GPS-TRACKED AF-LIQUID SPRAY SYSTEM DEPLOYED ON THE SYSTEM NETWORK.

C: WIRELESSLY TRANSMITTING THE SPRAY FIRE-PROTECTION TREATMENT DATA TO A CENTRAL NETWORK DATABASE ON THE SYSTEM NETWORK TO UPDATE THE CENTRAL NETWORK DATABASE ON THE SYSTEM NETWORK.

D: A COMPANY UNDERWRITING CAUSALITY INSURANCE FOR THE WOOD-FRAMED BUILDING ACCESSING THE CENTRAL NETWORK DATABASE ON THE SYSTEM NETWORK, TO VERIFY THE DATABASE RECORDS MAINTAINED FOR EACH SPRAY-BASED CLASS-A FIRE PROTECTION TREATMENT RELATING TO THE WOOD-FRAMED BUILDING, TO QUALIFY THE PROPERTY/BUILDING OWNER FOR LOWER CAUSALITY INSURANCE PREMIUMS, BASED ON THE VERIFIED CLASS-A FIRE-PROTECTION STATUS OF THE SPRAYED PROPERTY/BUILDING.

E: UPON THE OUTBREAK OF A WILD FIRE ABOUT THE INSURED WOOD-FRAMED BUILDING/PROPERTY, THE LOCAL FIRE DEPARTMENTS INSTANTLY AND REMOTELY ASSESSING THE CENTRAL NETWORK DATABASE, SO AS TO DETERMINE CLASS-A FIRE-PROTECTED STATUS OF THE WOOD-FRAMED BUILDING BY VIRTUE OF TIMELY CLEAN ANTI-FIRE (AF) CHEMICAL LIQUID APPLICATION ON THE PROPERTY, AND ADVISE FIREMAN FIGHTING AND MANAGING WILD FIRES THAT THE PROPERTY HAS BEEN PROPERLY DEFENDED AGAINST WILD FIRE.

FIG. 26

**METHOD OF AND APPARATUS FOR
APPLYING FIRE AND SMOKE INHIBITING
COMPOSITIONS ON GROUND SURFACES
BEFORE THE INCIDENCE OF WILD-FIRES,
AND ALSO THEREAFTER, UPON
SMOLDERING AMBERS AND ASHES TO
REDUCE SMOKE AND SUPPRESS FIRE
RE-IGNITION**

RELATED CASES

[0001] The present patent application is a Continuation-in-Part (CIP) of pending U.S. application Ser. No. 15/866,451 filed Jan. 9, 2018, which is a CIP of copending application Ser. No. 15/829,914 filed Dec. 2, 2017, commonly owned by M-Fire Suppression, Inc., and incorporated herein by reference as if fully set forth herein.

BACKGROUND OF INVENTION

Field of Invention

[0002] The present invention is directed towards improvements in science and technology applied in the defense of private and public property, and human and animal life, against the ravaging and destructive forces of wild fires caused by lightning, accident, arson and terrorism.

Brief Description of the State of Knowledge in the
Art

[0003] The US federal government spent more than 3 billion US dollars on wild fire defense this year only to lose record numbers of acreage and homes. These figures relate solely to the US Forest Service costs and do not include figures from federal, state or local firefighting agencies. Over 8 million acres were scorched in 2017, a 50% increase in what is normally burned. Some estimates of the property damage in Northern California fires alone is \$3 billion. The fires also killed more than 40 people and destroyed 8000 structures. Governor Brown of California is now asking President Trump for \$7.5 billion dollars to rebuild Santa Rosa. However, the real problem is that the conventional fire suppression methods are not working as needed to protect neighborhoods, homes, business and human life from the raging forces of wild fire. More money is being spent and more people are being deployed, but the benefits are not being realized. There is a great need for better methods and apparatus for suppressing wild fires

[0004] FIG. 1 provides a table listing the primary conventional methods used for fighting and defending against wild fires and forest fires, alike: aerial water dropping illustrated in FIG. 2A; aerial fire retardant chemical (e.g. Phos-Chek® Fire Retardant) dropping illustrated in FIGS. 2B1, 2B2 and 2B3; physical fire break by bulldozing, to stall the advance of wild fire; physical fire break by pre-burning, to stall the advance of wild fire; and chemical fire break by dropping fire retardant chemical such as Phos-Chek® chemical over land, to stall the advance of wild fire. While these methods are used, the results have not been adequate in most instances where wild fires are raging across land under strong winds.

[0005] Recently, the State of California deployed its CAL FIRE™ mobile application for smartphones and other mobile computing devices, to provide users with notifications on where wild fires are burning at a given moment in

time, the risks of wild fire in certain regions, ways of preparing for wild fires, and other useful information to help people stay out of harms way during a wild fire. However, this notification system in its current state does little to help home and business owners to proactively defend their homes and business against raging forces of wild fires in any meaningful way.

[0006] Clearly, there is a great need and growing demand for new and improved methods of and apparatus for providing improved defense and protection against wild fires, while overcoming the shortcomings and drawbacks of prior art methods and apparatus.

OBJECTS AND SUMMARY OF THE PRESENT
INVENTION

[0007] Accordingly, a primary object of the present is to provide new and improved method of and system and network for managing the supply, delivery and spray-application of environmentally-clean anti-fire (AF) liquid material on private and public properties to reduce the risks of damage and/or destruction to property and life caused by wild fires, while overcoming the shortcomings and drawbacks of prior art methods and apparatus.

[0008] Another object of the present is to provide method of reducing the risks of damage to private property due to wild fires by centrally managed application of AF chemical liquid spray to ground cover and building surfaces prior to arrival of the wild fires.

[0009] Another object of the present is to provide method of reducing the risks of damage to private property due to wild fires using a global positioning satellite (GPS) system and mobile communication messaging techniques, to help direct the application of AF chemical liquid prior to the arrival of wild fires.

[0010] Another object of the present invention is to provide a new and improved system for wild fire suppression and neighborhood and home defense comprising a platoon of small planes, all terrain vehicles (ATVs) and other mobile systems adapted for spraying an environmentally-clean anti-fire (AF) chemical liquid that clings to the ground cover, and buildings, where applied in regions of high wild fire risk, that operates in both wet and dry states of application.

[0011] Another object of the present invention is to provide a new and improved system for wild fire suppression and home defense system comprising (i) a plurality of home wild-fire defense systems assigned to each home or building in the strategic area, for spraying the outside of their homes and surrounding ground cover with the environmentally-clean anti-fire (AF) spray liquid, (ii) a command center for managing wild fire pre-defense operations in the region, involving the application of the environmentally-clean anti-fire (AF) spray liquid to create and maintain strategic fire breaks in the region in advance of the outbreak of wild fires, and protection of homes and property in the region against wild fires breaking out in the region, and sending messages and instructions to home owners in the region as well as operators of the small planes and ATVs deployed in the system, and (iii) a mobile application installed on the mobile phone of each home owner in the strategic region, and configured for receiving email and/or SMS messages from a command center managing the system, and instructing home owners to pre-defend their homes using the environmentally-clean anti-fire spray liquid.

[0012] Another object of the present invention is to provide a new and improved system for wild fire suppression and home defense system, wherein each home defense spray system includes a GPS-tracking and radio-controlled circuit board to remotely monitor the location of each location-deployed home defense spray system and automatically monitor the anti-fire chemical liquid level in its storage tank, and automatically generate electronic refill orders sent to the command center, so that a third-party service can automatically replenish the tanks of such home-based systems with anti-fire liquid when the fluid level falls below a certain level in the GPS-tracked tank.

[0013] Another object of the present invention is to provide a new and improved system for wild fire suppression and home defense system, wherein the mobile application supporting the following functions: (i) sends automatic notifications from the command center to home owners with the mobile application, instructing them to spray their property and home at certain times with anti-fire chemical liquid in their tanks; (ii) the system will automatically monitor consumption of sprayed AF chemical liquid and generate auto-replenish order via its onboard GSM-circuits so as to achieve compliance with the home spray-based wild-fire-defense program, and report anti-fire liquid levels in each home-owner tank; and (iii) show status of wild fire risk in the region, and actions to be taken before wild fire outbreak.

[0014] Another object of the present invention is to provide a GPS-guided method of suppressing a wild fire raging towards a target region of land in a direction determined by currently blowing winds and other environmental and weather factors.

[0015] Another object of the present invention is to provide a method of reducing the risks of damage to public property due to wild fires by managed application of AF chemical liquid spray to ground cover and building surfaces prior to arrival of the wild fires.

[0016] Another object of the present invention is to provide a wireless system for managing the supply, delivery and spray-application of environmentally-clean anti-fire (AF) liquid on private and public property to reduce the risks of damage and/or destruction caused by wild fires.

[0017] Another object of the present invention is to provide a new and improved system for spraying a defensive path around vulnerable neighborhoods out in front of wild fires to make sure that an environmentally-safe fire break, created by the spray application of anti-fire (AF) liquid, defends homes from the destructive forces of raging wild fires.

[0018] Another object of the present invention is to provide a new and improved system and method of mitigating the damaging effects of wild fires by spraying environmentally-clean anti-fire (AF) chemical liquid in advance of wild fires, that do not depend on water to extinguish fire, such that, even after a month or two after spray application on dry brush around the neighborhood, the anti-fire chemical continues to work by stalling the ability of a fire to advance and consume homes.

[0019] Another object of the present invention is to provide new and improved methods of and apparatus for protecting wood-framed buildings from wild fires by automatically spraying water-based environmentally clean anti-fire chemical liquid over the exterior surfaces of the building, surrounding ground surfaces, shrubs, decking and the like, prior to wild fires reaching such buildings.

[0020] Another object of the present invention is to provide new and improved method of suppressing a wild fire raging across a region of land in the direction of the prevailing winds, by forming a multi-stage anti-fire (AF) chemical fire-break system comprising the step of (a) applying, prior to the wild fire reaching the specified target region of land, a low-density anti-fire (AF) liquid mist in advance of the wild fire so as to form a fire stall region, while providing a non-treated region of sufficient size between the front of the wild fire approaching the target region of land and the fire stall region, and (b) also applying a high-density anti-fire (AF) liquid spray in advance of the wild fire to form a fire break region beyond and contiguous with said fire stall region, wherein the fire stall region is formed before the wild fire reaches the fire stall region, and operates to reduce the free-radical chemical reactions raging in the wild fire so as to reduce the destructive energy of the wild fire by the time the wild fire reaches the fire break region, and enabling the fire break region to operate and significantly break the free radical chemical reactions in the wild fire when the wild fire reaches the fire break region, and thereby suppress the wild fire and protect the target region of land.

[0021] Another object of the present invention is to provide a new and improved method of and system network qualifying real property for reduced property insurance based on verified spray-based clean anti-fire (AF) chemical liquid treatment prior to presence of wild fires.

[0022] Another object of the present invention is to provide a method of and apparatus for applying fire and smoke inhibiting compositions on ground surfaces before the incidence of wild-fires, and also thereafter, upon smoldering ambers and ashes to reduce smoke and suppress fire re-ignition.

[0023] Another object of the present invention is to provide a method of and apparatus applying by an aqueous-based fire and smoke inhibiting slurry formulation that can hydraulically sprayed around whole neighborhoods to create strategic chemical-type fire breaks that remove wild fire energy before such wildfires arrive at the doors of homes and businesses.

[0024] Another object of the present invention is to provide a method of spraying a clean fire and smoke inhibiting slurry composition containing clean fire inhibiting chemicals, and cellulose or wood fiber, mixed with water and other additives, for application to ground surfaces in advance of wild fire, to blanket grounds from wildfire ignition, and also application over smoldering ambers and ashes to prevent resignation while saving millions of gallons of water, and producing considerable waste water and reducing toxic runoff, while reducing toxic smoke.

[0025] Another object of the present invention is to provide equipment for applying such fire and smoke inhibiting slurry mixtures to ground surfaces, after the presence of wildfire, to prevent smoke smoldering and resignation of fires, without creating toxic water runoff which occurs using conventional methods based on the application of water by fire hoses.

[0026] These and other benefits and advantages to be gained by using the features of the present invention will become more apparent hereinafter and in the appended Claims to Invention.

BRIEF DESCRIPTION OF THE DRAWINGS

[0027] The following Objects of the Present Invention will become more fully understood when read in conjunction of the Detailed Description of the Illustrative Embodiments, and the appended Drawings, wherein:

[0028] FIG. 1 is a table listing conventional prior art methods for fighting and defending against wild fires including (i) aerial water drop methods using airplanes and helicopters, (ii) aerial fire retardant chemical (e.g. Phos-Chek® Fire Retardant) drop using airplanes and helicopters, (iii) physical fire breaks formed by bulldozing land and other landscaping methods to remove combustible vegetation from the land, (iv) physical fire breaks by pre-burning combustible material on the land, and (v) chemical fire break by fire retardant chemical drop;

[0029] FIG. 2A is a first image illustrating a prior art method of wild fire suppression involving an airplane dropping water on a wild fire from the sky;

[0030] FIG. 2B1 is a second image illustrating a prior art method of wild fire suppression involving an airplane dropping chemical fire retardant (e.g. Phoscheck) on a wild fire from the sky;

[0031] FIG. 2B2 is third image showing a prior art ground-based tank containing the chemical fire retardant (e.g. Phoscheck® fire retardant chemical) that is shown being contained in a storage tank in FIG. 2B2, and dropped from an airplane in FIG. 2B1;

[0032] FIG. 2B3 is a fourth image showing a prior art ground-based tank containing a supply of Phoscheck® fire retardant chemical mixed in the tank shown in FIG. 2B3, and dropped from an airplane in FIG. 2B1;

[0033] FIGS. 3A, 3B, 3C, 3D and 3E show some exemplary graphical user interfaces (GUI) screens supported by the prior art CAL FIRE™ mobile application running on an Apple iPhone™ device, or other mobile computing device, designed to help members of the public to prepare for wild fires;

[0034] FIG. 4 is schematic representation of the wireless system network of the present invention designed for managing the supply, delivery and spray-application of environmentally-clean anti-fire (AF) liquid on private and public property to reduce the risks of property damage and/or destruction and harm to life caused by wild fires, and shown comprising GPS-tracked anti-fire (AF) liquid spray ground vehicles, GPS-tracked anti-fire liquid spray air vehicles, GPS-tracked anti-fire liquid spray backpack systems for spraying houses and surrounding properties, GPS-tracked anti-fire liquid spraying systems for spraying private real property and buildings, GPS-tracked liquid spraying systems for spraying public real property and buildings, mobile computing systems running the mobile application of the present invention and used by property owners, residents, fire departments, insurance underwriters, government officials, medical personal and others, remote data sensing and capturing systems for remotely monitoring land and wild fires wherever they may break out, a GPS system for providing GPS-location services to each and every system components in the system network, and one or more data center containing clusters of web, application and database servers for supporting wire wild alert and notification systems, and microservices configured for monitoring and managing the system and network of GPS-tracking anti-fire liquid spraying systems and mobile computing and commu-

nication devices configured in accordance with the principles of the present invention;

[0035] FIG. 4A is a schematic representation illustrating exemplary multispectral imaging (MSI) and hyperspectral imaging (HSI) based remote sensing technology platforms supported by the US Geological Survey (USGS) Agency including, for example, the MODIS (Moderate Resolution Imaging Spectroradiometer) satellite system, the World View 2 Satellite System, the Octocopter unmanned airborne system (UAS) (e.g. OnyxStar Hyra-12 heavy lifting drone), and the SenseFly eBee SQ UAS, for use in supporting and practicing the system network of the present invention;

[0036] FIG. 4B is a perspective view of the OnyxStar Hyra-12 heavy lifter drone supporting MSI and HSI camera systems, and providing remote data sensing services that can be used to help carry out the GPS-directed methods of wild fire suppression disclosed herein in accordance with the principles of the present invention;

[0037] FIG. 5A is a perspective view of an exemplary mobile computing device deployed on the system network of the present invention, supporting (i) the mobile anti-fire spray management application of the present invention deployed as a component of the system network of the present invention as shown in FIGS. 12 through 13D, as well as (ii) conventional wildfire alert and notification systems as shown in FIGS. 3A through 3E;

[0038] FIG. 5B shows a system diagram for an exemplary mobile client computer system deployed on the system network of the present invention;

[0039] FIG. 6A is a perspective view of a mobile GPS-tracked anti-fire (AF) liquid spraying system supported on a set of wheels, with integrated supply tank and rechargeable-battery operated electric spray pump, for deployment at private and public properties having building structures, for spraying the same with environmentally-clean anti-fire (AF) liquid in accordance with the principles of the present invention;

[0040] FIG. 6B is a schematic representation of the GPS-tracked mobile anti-fire (AF) chemical liquid spraying system shown in FIG. 6A, comprising a GPS-tracked and remotely-monitored AF chemical liquid spray control subsystem interfaced with a micro-computing platform for monitoring the spraying of AF chemical liquid from the system when located at specific GPS-indexed location coordinates, and automatically logging and recording such AF spray application operations within the network database system;

[0041] FIG. 7A is a perspective view of a GPS-tracked manned or autonomous vehicle system for spraying AF chemical liquid on building and ground surfaces for spraying the same with environmentally-clean anti-fire (AF) chemical liquid in accordance with the principles of the present invention;

[0042] FIG. 7B is a schematic representation of the manned or autonomously-driven vehicle system shown in FIG. 7A, comprising a GPS-tracked and remotely-monitored AF chemical liquid spray control subsystem interfaced with a micro-computing platform for monitoring the spraying of AF chemical liquid from the vehicle when located at any specific GPS-indexed location coordinates, and automatically logging and recording such AF spray application operations within the network database system;

[0043] FIG. 8A is a perspective view of an autonomously-driven or remotely-controlled unmanned airborne system

(i.e. UAS or “drone”) adapted for spraying AF chemical liquid on building and ground surfaces for spraying the same with environmentally-clean anti-fire (AF) liquid in accordance with the principles of the present invention;

[0044] FIG. 8B is a schematic representation of the autonomously-driven or remotely-controlled aircraft system (i.e. drone) shown in FIG. 8A, comprising a GPS-tracked and remotely monitored AF chemical liquid spray control subsystem interfaced with a micro-computing platform for monitoring the spraying of AF chemical liquid from the aircraft when located at specific GPS-indexed location coordinates, and automatically logging and recording such AF spray application operations within the network database system;

[0045] FIG. 9A is a perspective view of a GPS-tracked aircraft system (i.e. helicopter) adapted for spraying an environmentally-clean anti-fire (AF) liquid AF chemical liquid, from the air, onto ground surfaces in accordance with the principles of the present invention;

[0046] FIG. 9B is a schematic representation of the GPS-tracked aircraft system (i.e. helicopter) shown in FIG. 9A, comprising a GPS-tracked and remotely monitored AF chemical liquid spray control subsystem interfaced with a micro-computing platform for monitoring the spraying of AF chemical liquid from the aircraft when located at specific GPS-indexed location coordinates, and automatically logging and recording such AF spray application operations within the network database system;

[0047] FIG. 10A is a GPS-tracked all terrain vehicle (ATV) system adapted for spraying ground surfaces with anti-fire (AF) liquid in accordance with the principles of the present invention;

[0048] FIG. 10B is the GPS-tracked all terrain vehicle (ATV) system shown in FIG. 10A, comprising a GPS-tracked and remotely-monitored AF chemical liquid spray control subsystem interfaced with a micro-computing platform for monitoring the spraying of AF chemical liquid from the ATV system when located at specific GPS-indexed location coordinates, and automatically logging and recording such AF spray application operations within the network database system;

[0049] FIG. 11 is a schematic representation of a schema for the network database (RDBMS) supported by the system network of the present invention, showing the primary enterprise level objects supported in the database tables created in the network database using the schema, and the relationships that are specified or indicated;

[0050] FIG. 12 is an exemplary wire-frame model of a graphical user interface supported by mobile application configured for use by a first specific class of registered users (e.g. property parcel owners, contractors and/or agents, residents, government officials, and others) to request and receive services, including notices and orders, supported by the system network of the present invention;

[0051] FIG. 12A is an exemplary wire-frame model of a graphical user interface supported by the mobile application showing a user updating the registration profile as a task on the system network;

[0052] FIG. 12B is an exemplary wire-frame model of a graphical user interface supported by the mobile application showing a user receiving a message request (via email, SMS messaging and/or push-notifications) issued from the com-

mand center to spray GPS-specified private property parcel (s) with clean anti-fire (AF) chemical liquid and registered equipment;

[0053] FIG. 12C is an exemplary wire-frame model of a graphical user interface supported by the mobile application showing a user receiving a request/notice of order (via email, SMS messaging and/or push-notifications) to wild-fire spray-protect GPS-specified public property parcel(s) with clean anti-fire (AF) liquid to create and maintain a GPS-specified public firebreak, maintained on public property;

[0054] FIG. 12D is an exemplary wire-frame model of a graphical user interface supported by the mobile application showing a user requesting a refill supply of clean anti-fire (AF) chemical liquid for supply to GPS-specified spray equipment registered on the system network;

[0055] FIG. 13 is an exemplary wire-frame model of a graphical user interface supported by the mobile application configured for second specific class of registered users, namely, command center administrators, enabling such users to issue wild-fire protection orders, plan wild-fire protection tasks, generate wild-fire and protection reports, and send and receive messages to users on the system network;

[0056] FIG. 13A is an exemplary wire-frame model of a graphical user interface supported by the mobile application for use by command center administrators to issue wild-fire protection orders using the system network of the present invention;

[0057] FIG. 13B exemplary wire-frame model of a graphical user interface supported by the mobile application for use by command center administrators to issue wild-fire protection orders involving the creation and maintenance of a clean AF-based chemical firebreak using the methods of the present invention, as illustrated in FIGS. 18 through 25B;

[0058] FIG. 13C is an exemplary wire-frame models of a graphical user interface supported by the mobile application for use by command center administrators to order the creation and/or maintenance of a GPS-specified clean AF-based chemical firebreak on one or more public/private property parcels, using the methods of the present invention;

[0059] FIG. 13D is a exemplary wire-frame models of a graphical user interface for the mobile application used by command center administrators to receive messages from users including property owners and contractors requesting refills for clean anti-fire (AF) chemical liquid for GPS-specified spray system equipment;

[0060] FIG. 14 is a graphical representation of an exemplary fire hazard severity zone (FHSZ) map generated by the CAF FIRE™ System in state responsibility areas of the State of California, and accessible through the mobile application, for use while informing the strategic application of environmentally-clean anti-fire (AF) liquid spray onto specified regions of property prior to the arrival of wild fires, using the system network of the present invention;

[0061] FIG. 15 is an exemplary anti-fire (AF) spray protection map generated by the system network of the present invention, showing houses and buildings that have been sprayed, and not-sprayed, with state/county-issued clean anti-fire (AF) liquid as of the report date 15 Dec. 2017;

[0062] FIG. 16 is an exemplary anti-fire spray protection task report generated by the system of the present invention for state/county xxx on 15 Dec. 2017, indicating which

properties on what streets, in what town, county, state, requires the reapplication of AF chemical liquid spray treatment in view of factors such as weather (e.g. rainfall, sunlight) and passage of time since last AF chemical liquid spray application;

[0063] FIG. 17 is a schematic representation showing a plan view of a wild fire emerging from a forest region and approaching a neighboring town moving in the direction of prevailing winds;

[0064] FIG. 18 is a graphical representation illustrating a method of suppressing a wild fire raging across a region of land in the direction of the prevailing winds, by forming a multi-stage anti-fire (AF) chemical fire-break system, by GPS-controlled application of anti-fire (AF) liquid mist and spray streams, wherein the method comprises the step of (a) applying, prior to the wild fire reaching the specified target region of land, a low-density anti-fire (AF) liquid mist in advance of the wild fire so as to form a fire stall region, while providing a non-treated region of sufficient size between the front of the wild fire approaching the target region of land and the fire stall region, and (b) also applying a high-density anti-fire (AF) liquid spray in advance of the wild fire to form a fire break region beyond and contiguous with said fire stall region, wherein the fire stall region is formed before said wild fire reaches the fire stall region, and operates to reduce the free-radical chemical reactions raging in the wild fire so as to reduce the destructive energy of the wild fire by the time the wild fire reaches the fire break region, and enabling the fire break region to operate and significantly break the free radical chemical reactions in the wild fire when the wild fire reaches the fire break region, and thereby suppress the wild fire and protect the target region of land;

[0065] FIGS. 19A and 19B, through, set forth a flow chart describing the high level steps of the method of suppressing a wild fire raging towards a target region of land in a direction determined by prevailing winds and other environmental and weather factors, as schematically illustrated in FIG. 18;

[0066] FIG. 20 is a graphical representation illustrating a method of reducing the risks of damage to private property due to wild fires by GPS-controlled application of anti-fire (AF) liquid spray, using the system network of the present invention;

[0067] FIGS. 21A, 21B and 21C, taken together, set forth a flow chart describing the high level steps carried out by the method of reducing the risks of damage to private property due to wild fires by managed application of anti-fire (AF) liquid spray, using the system network and methods of the present invention;

[0068] FIG. 22 is a graphical illustration showing a method of reducing the risks of damage to public property due to wild fires, by GPS-controlled application of anti-fire (AF) chemical liquid spray over ground cover and building surfaces prior to the arrival of wild fires, using the system network and methods of the present invention;

[0069] FIGS. 23A, 23B and 23C, taken together, set forth a flow chart describing the high level steps carried out by the method of reducing the risks of damage to public property due to wild fires by GPS-controlled application of anti-fire (AF) liquid spray, using the system network and methods of the present invention;

[0070] FIG. 24 is a graphical illustration showing a method of remotely managing the GPS-controlled application of anti-fire (AF) liquid spray to ground cover and

buildings so as to reduce the risks of damage due to wild fires, using the system network and methods of the present invention;

[0071] FIGS. 25A and 25B, taken together, set forth a flow chart describing the high level steps carried out by the method of GPS-controlled application of anti-fire (AF) liquid spray to ground cover and buildings so as to reduce the risks of damage due to wild fires, using the system network and methods of the present invention;

[0072] FIG. 26 is a flow chart describing the primary steps of the method of qualifying real property for reduced property insurance, based on verified spray-based clean anti-fire (AF) chemical liquid treatment prior to presence of wild fires, using the system network and methods of the present invention;

[0073] FIG. 27A is a perspective view of the clean fire and smoke inhibiting slurry spray application vehicle carrying a high-capacity (e.g. 3000 gallon) stainless steel mixing tank with an integrated agitator mechanism (e.g. motor driven mixing paddles) for mixing the mixture, and a hydraulic pumping apparatus and spray nozzle for spraying the clean aqueous-based clean fire and smoke inhibiting slurry on ground surfaces to create CFIC-based fire breaks around regions to be protected from wildfires, and also to cover smoldering ambers and ash after the present of wildfires to reduce toxic water runoff and smoke production;

[0074] FIG. 27B is a rear view of the vehicle shown in FIG. 27A;

[0075] FIG. 27C is a side view of the vehicle shown in FIG. 27A;

[0076] FIG. 28 is a schematic system block diagram of the fire and smoke inhibiting slurry spray vehicle shown in FIGS. 27A, 27B and 27C;

[0077] FIG. 29 is a flow chart describing the method of applying fire and smoke inhibiting slurry compositions of the present invention on ground surfaces before the incidence of wild-fires, and also thereafter, upon smoldering ambers and ashes to reduce smoke and suppress fire re-ignition;

[0078] FIG. 30 is a base hydraulic mulch loading chart for making the fire and smoke inhibiting slurry mixture of the present invention, using Profile® brand mulch fiber, for several different application rates measured in lbs./acre (e.g. 1500 lbs./acre, 2000 lb./acre, and 2500 lb./acre);

[0079] FIG. 31 is a schematic representation of a neighborhood of houses surrounded by a high-risk wildfire region, wherein a CFIC-based wild-fire break region is hydraulically sprayed on the ground surface region all around the houses using the clean fire and smoke inhibiting slurry composition of the present invention;

[0080] FIG. 32 is a schematic representation of a highway surrounded by a high-risk wildfire region on both sides, wherein a CFIC-based wild-fire break region is hydraulically sprayed on both sides of the highway using the clean fire and smoke inhibiting slurry composition of the present invention;

[0081] FIG. 33 is a schematic representation of a house that just burned to the ground after a wildfire passed through an unprotected neighborhood, wherein the clean fire and smoke inhibiting slurry composition is hydraulically sprayed over the glowing ambers and fire ash to suppress and prevent resignation of the fire, and reduce the production of smoke and creation of toxic water runoff during post fire management operations; and

[0082] FIG. 34 is a schematic representation of a house that is burning due to a fire within the building, wherein the wet fire and smoke inhibiting slurry composition of the present invention is hydraulically sprayed on and over the fire to suppress it, while reducing the production of smoke during the fire suppression process.

DETAILED DESCRIPTION OF THE
ILLUSTRATIVE EMBODIMENTS OF THE
PRESENT INVENTION

[0083] Referring to the accompanying Drawings, like structures and elements shown throughout the figures thereof shall be indicated with like reference numerals.

Wireless System Network for Managing the Supply, Delivery and Spray-Application of Environmentally-Clean Anti-Fire (AF) Liquid on Private and Public Property to Reduce the Risks of Damage and/or Destruction Caused by Wild Fires

[0084] FIG. 4 shows the wireless system network of the present invention 1 designed for managing the supply, delivery and spray-application of environmentally-clean anti-fire (AF) liquid on private and public property to reduce the risks of damage and/or destruction caused by wild fires. As shown, the wireless system network 1 comprises a distribution of system components, namely: GPS-tracked anti-fire (AF) liquid spray ground vehicles 2 (e.g. all terrain vehicles or ATVs) as shown in FIGS. 7A and 7B, and 10A and 10B, for applying AF chemical liquid spray (e.g. Hartindo AF31 fire inhibitor chemical from Hartindo Chemical, Indonesia) from the ground to ground surfaces, brush, and other forms of organic material; GPS-tracked anti-fire liquid spray air-based vehicles 3 as shown in FIGS. 9A, 9B, and 8A, 8B for applying AF chemical liquid spray (e.g. Hartindo AF31 fire inhibitor chemical liquid) from the air to ground surfaces, brush, bushes and other forms of organic material; GPS-tracked mobile anti-fire liquid spraying systems 4 (e.g. including wheel supported, and back-pack-carried systems) as shown in FIGS. 6A and 6B for applying AF chemical liquid spray (e.g. Hartindo AF31 fire inhibitor chemical liquid) to ground surfaces, brush, bushes, decks, houses, buildings, and other forms of organic material and property surrounding houses; GPS-tracked/GSM-linked anti-fire liquid spraying systems 5 as shown in FIGS. 10A, 10B, 8A, 8B, and 7A, 7B for applying AF chemical liquid spray (e.g. Hartindo AF31 fire inhibitor chemical liquid) to private real property, buildings and surrounding areas; GPS-tracked/GSM-linked liquid spraying systems 6 as shown in FIGS. 10A, 10B, 8A, 8B, and 7A, 7B for applying AF chemical liquid spray (e.g. Hartindo AF31 fire inhibitor chemical liquid) to public real property and buildings and surrounding properties; a GPS-indexed real-property (land) database system 7 for storing the GPS coordinates of the vertices and maps of all land parcels, including private property and building 17 and public property and building 18, situated in every town, county and state in the region over which the system network 1 is used to manage wild fires as they may occur; a cellular phone, GSM, and SMS messaging systems and email servers, collectively 16; and one or more data centers 8 for monitoring and managing GPS-tracking/GSM-linked anti-fire (AF) liquid supply and spray systems, including web servers 9A, application servers 9B and database servers 9C (e.g. RDBMS) operably connected to the TCP/IP infrastructure of the Internet 10, and including a network database 9C1, for monitoring and

managing the system and network of GPS-tracking anti-fire liquid spraying systems and various functions supported by the command center 19, including the management of wild fire suppression and the GPS-guided application of anti-fire (AF) chemical liquid over public and private property, as will be described in greater technical detail hereinafter. As shown, each data center 8 also includes an SMS server 9D and an email message server 9E for communicating with registered users on the system network 1 who use a mobile computing device (e.g. an Apple® iPhone or iPad tablet) 11 with the mobile application 12 installed thereon and configured for the purposes described herein. Such communication services will include SMS/text, email and push-notification services known in the mobile communications arts.

[0085] As shown in FIG. 4, the GPS-indexed real-property (land) database system 7 will store the GPS coordinates of the vertices and maps of all land parcels contained in every town, county and state of the region over which the system network is deployed and used to manage wild fires as they may occur. Typically, databases and data processing methods, equipment and services known in the GPS mapping art, will be used to construct and maintain such GPS-indexed databases 7 for use by the system network of the present invention, when managing GPS-controlled application of clean anti-fire (AF) chemical liquid spray and mist over GPS-specified parcels of land, at any given time and date, under the management of the system network of the present invention. Examples of such GPS-indexed maps of land parcels are reflected by the task report shown in FIG. 16, and examples of GPS-indexed maps are shown in the schematic illustrations depicted in FIGS. 18, 20, 22 and 24.

[0086] As shown in FIG. 4, the system network 1 also includes a GPS system 100 for transmitting GPS reference signals transmitted from a constellation of GPS satellites deployed in orbit around the Earth, to GPS transceivers installed aboard each GPS-tracking ground-based or air-based anti-fire (AF) liquid misting/spraying system of the present invention, shown in FIGS. 6A through 10B, as part of the illustrative embodiments. From the GPS signals it receives, each GPS transceiver aboard such AF liquid spraying/misting systems is capable of computing in real-time the GPS location of its host system, in terms of longitude and latitude. In the case of the Empire State Building in NYC, N.Y., its GPS location is specified as: N40° 44.9064', W073° 59.0735'; and in number only format, as: 40.748440, -73.984559, with the first number indicating latitude, and the second number representing longitude (the minus sign indicates "west").

[0087] As shown in FIG. 4, the system network 1 further includes multi-spectral imaging (MSI) systems and/or hyper-spectral-imaging (HSI) systems 14 for remotely data sensing and gathering data about wild fires and their progress. Such MSI and HSI systems may be space/satellite-based and/or drone-based (supported on an unmanned airborne vehicle or UAV). Drone-based systems can be remotely-controlled by a human operator, or guided under an artificial intelligence (AI) navigation system. Such AI-based navigation systems may be deployed anywhere, provided access is given to such remote navigation system the system network and its various systems. Typically, the flight time will be limited to under 1 hour using currently available battery technology, so there will be a need to provide provisions for recharging the batteries of such drones/UASs

in the field, necessitating the presence of human field personnel to support the flight and remote data sensing and mapping missions of each such deployed drone, flying about raging wild fires, in connection with the system network of the present invention.

[0088] During each wild fire data sensing and mapping mission, carried out by such UAS, a series of MSI images and HSI images can be captured during a wild fire, and mapped to GPS-specific coordinates, and this mapped data can be transmitted back to the system network for storage, analysis and generation of GPS-specified flight plans for anti-fire (AF) chemical liquid spray and misting operations carried out using the methods illustrated in FIGS. 17, 18, 19A and 19B seeking to stall and suppress such wild fires, and mitigate risk of damage to property and harm to human and animal life.

[0089] FIG. 4A shows a suite of MSI and HSI remote sensing and mapping instruments and technology 14 that is currently being used by the US Geological Survey (USGS) Agency to collect, monitor, analyze, and provide science about natural resource conditions, issues, and problems on Earth. It is an object of the present invention to exploit such instruments and technology when carrying out and practicing the various methods of the present invention disclosed herein. As shown in FIG. 4A, these MSI/HSI remote sensing technologies 14 include: MODIS (Moderate Resolution Imaging Spectro-radiometer) satellite system 14A for generating MODIS imagery subsets from MODIS direct readout data acquired by the USDA Forest Service Remote Sensing Applications Center, to produce satellite fire detection data maps and the like <https://fsapps.nwcc.gov/afm/activefire-maps.php>; the World View 2 Satellite System 14B manufacture from the Ball Aerospace & Technologies and operated by DigitalGlobe, for providing commercially available panchromatic (B/W) imagery of 0.46 meter resolution, and eight-band multi-spectral imagery with 1.84 meter resolution; Octocopter UAS (e.g. OnyxStar Hyra-12 heavy lifting drone) 14C as shown in FIG. 4B supporting MSI and HSI camera systems for spectral imaging applications, <http://www.onyxstar.net> and <http://www.genidrone.com>; and SenseFly eBee SQ UAS 14D for capturing and mapping high-resolution aerial multi-spectral images <https://www.sensefly.com/drones/eebe-sq.html>.

[0090] Any one or more of these types of remote data sensing and capture instruments, tools and technologies can be integrated into and used by the system network 1 for the purpose of (i) determining GPS-specified flight/navigation plans for GPS-tracked anti-fire (AF) chemical liquid spraying and misting aircraft and ground-based vehicle systems, respectively, shown in FIGS. 9A, 9B, 8A, 8B, 10A, 10B, and 7A, 7B, and (ii) practicing the various GPS-guided methods of wild fire suppression illustrated in FIGS. 17 through 25B, and described in detail herein.

Specification of the Network Architecture of the System Network of the Present Invention

[0091] FIG. 4 illustrates the network architecture of the system network 1 implemented as a stand-alone platform deployed on the Internet. As shown, the Internet-based system network comprises: cellular phone and SMS messaging systems and email servers 16 operably connected to the TCP/IP infrastructure of the Internet 10; a network of mobile computing systems 11 running enterprise-level mobile application software 12, operably connected to the

TCP/IP infrastructure of the Internet 10; an array of mobile GPS-tracked anti-fire (AF) liquid spraying systems (20, 30, 40, 50), each provided with GPS-tracking and having wireless internet connectivity with the TCP/IP infrastructure of the Internet 10, using various communication technologies (e.g. GSM, BlueTooth, WIFI, and other wireless networking protocols well known in the wireless communications arts); and one or more industrial-strength data center(s) 8, preferably mirrored with each other and running Border Gateway Protocol (BGP) between its router gateways, and operably connected to the TCP/IP infrastructure of the Internet 10.

[0092] As shown in FIG. 4, each data center 8 comprises: the cluster of communication servers 9A for supporting http and other TCP/IP based communication protocols on the Internet (and hosting Web sites); a cluster of application servers 9B; the cluster of RDBMS servers 9C configured within a distributed file storage and retrieval ecosystem/system, and interfaced around the TCP/IP infrastructure of the Internet well known in the art; the SMS gateway server 9D supporting integrated email and SMS messaging, handling and processing services that enable flexible messaging across the system network, supporting push notifications; and the cluster of email processing servers 9E.

[0093] Referring to FIG. 4, the cluster of communication servers 9A is accessed by web-enabled mobile computing clients 11 (e.g. smart phones, wireless tablet computers, desktop computers, computer workstations, etc) used by many stakeholders accessing services supported by the system network 1. The cluster of application servers 9A implement many core and compositional object-oriented software modules supporting the system network 1. Typically, the cluster of RDBMS servers 9C use SQL to query and manage datasets residing in its distributed data storage environment, although non-relational data storage methods and technologies such as Apache's Hadoop non-relational distributed data storage system may be used as well.

[0094] As shown in FIG. 4, the system network architecture shows many different kinds of users supported by mobile computing devices 11 running the mobile application 12 of the present invention, namely: the plurality of mobile computing devices 11 running the mobile application 12, used by fire departments and firemen to access services supported by the system network 1; the plurality of mobile computing systems 11 running mobile application 12, used by insurance underwriters and agents to access services on the system network 1; the plurality of mobile computing systems 11 running mobile application 12, used by building architects and their firms to access the services supported by the system network 1; the plurality of mobile client systems 11 (e.g. mobile computers such as iPad, and other Internet-enabled computing devices with graphics display capabilities, etc) used by spray-project technicians and administrators, and running a native mobile application 12 supported by server-side modules, and the various illustrative GUIs shown in FIGS. 12 through 13D, supporting client-side and server-side processes on the system network of the present invention; and a GPS-tracked anti-fire (AF) liquid spraying systems 20, 30, 40 and 50 for spraying buildings and ground cover to provide protection and defense against wild-fires.

[0095] In general, the system network 1 will be realized as an industrial-strength, carrier-class Internet-based network of object-oriented system design, deployed over a global data packet-switched communication network comprising

numerous computing systems and networking components, as shown. As such, the information network of the present invention is often referred to herein as the “system” or “system network”. The Internet-based system network can be implemented using any object-oriented integrated development environment (IDE) such as for example: the Java Platform, Enterprise Edition, or Java EE (formerly J2EE); Websphere IDE by IBM; Weblogic IDE by BEA; a non-Java IDE such as Microsoft’s .NET IDE; or other suitably configured development and deployment environment well known in the art. Preferably, although not necessary, the entire system of the present invention would be designed according to object-oriented systems engineering (DOSE) methods using UML-based modeling tools such as ROSE by Rational Software, Inc. using an industry-standard Rational Unified Process (RUP) or Enterprise Unified Process (EUP), both well known in the art. Implementation programming languages can include C, Objective C, C, Java, PHP, Python, Google’s GO, and other computer programming languages known in the art. Preferably, the system network is deployed as a three-tier server architecture with a double-firewall, and appropriate network switching and routing technologies well known in the art. In some deployments, private/public/hybrid cloud service providers, such as Amazon Web Services (AWS), may be used to deploy Kubernetes, an open-source software container/cluster management/orchestration system, for automating deployment, scaling, and management of containerized software applications, such as the mobile enterprise-level application 12 of the present invention, described above.

Specification of System Architecture of an Exemplary Mobile Smartphone System Deployed on the System Network of the Present Invention

[0096] FIG. 5A shows an exemplary mobile computing device 11 deployed on the system network of the present invention, supporting conventional wildfire alert and notification systems (e.g. CAL FIRE® wild fire notification system 14), as well as the mobile anti-fire spray management application 12 of the present invention, that is deployed as a component of the system network 1.

[0097] FIG. 5B shows the system architecture of an exemplary mobile client computing system 11 that is deployed on the system network 1 and supporting the many services offered by system network servers 9A, 9B, 9C, 9D, 9E. As shown, the mobile smartphone device 11 can include a memory interface 202, one or more data processors, image processors and/or central processing units 204, and a peripherals interface 206. The memory interface 202, the one or more processors 204 and/or the peripherals interface 206 can be separate components or can be integrated in one or more integrated circuits. The various components in the mobile device can be coupled by one or more communication buses or signal lines. Sensors, devices, and subsystems can be coupled to the peripherals interface 206 to facilitate multiple functionalities. For example, a motion sensor 210, a light sensor 212, and a proximity sensor 214 can be coupled to the peripherals interface 206 to facilitate the orientation, lighting, and proximity functions. Other sensors 216 can also be connected to the peripherals interface 206, such as a positioning system (e.g. GPS receiver), a temperature sensor, a biometric sensor, a gyroscope, or other sensing device, to facilitate related functionalities. A camera subsystem 220 and an optical sensor 222, e.g. a charged coupled device

(CCD) or a complementary metal-oxide semiconductor (CMOS) optical sensor, can be utilized to facilitate camera functions, such as recording photographs and video clips. Communication functions can be facilitated through one or more wireless communication subsystems 224, which can include radio frequency receivers and transmitters and/or optical (e.g. infrared) receivers and transmitters. The specific design and implementation of the communication subsystem 224 can depend on the communication network(s) over which the mobile device is intended to operate. For example, the mobile device 11 may include communication subsystems 224 designed to operate over a GSM network, a GPRS network, an EDGE network, a Wi-Fi or WiMax network, and a Bluetooth™ network. In particular, the wireless communication subsystems 224 may include hosting protocols such that the device 11 may be configured as a base station for other wireless devices. An audio subsystem 226 can be coupled to a speaker 228 and a microphone 230 to facilitate voice-enabled functions, such as voice recognition, voice replication, digital recording, and telephony functions. The I/O subsystem 240 can include a touch screen controller 242 and/or other input controller(s) 244. The touch-screen controller 242 can be coupled to a touch screen 246. The touch screen 246 and touch screen controller 242 can, for example, detect contact and movement or break thereof using any of a plurality of touch sensitivity technologies, including but not limited to capacitive, resistive, infrared, and surface acoustic wave technologies, as well as other proximity sensor arrays or other elements for determining one or more points of contact with the touch screen 246. The other input controller(s) 244 can be coupled to other input/control devices 248, such as one or more buttons, rocker switches, thumb-wheel, infrared port, USB port, and/or a pointer device such as a stylus. The one or more buttons (not shown) can include an up/down button for volume control of the speaker 228 and/or the microphone 230. Such buttons and controls can be implemented as a hardware objects, or touch-screen graphical interface objects, touched and controlled by the system user. Additional features of mobile smartphone device 11 can be found in U.S. Pat. No. 8,631,358 incorporated herein by reference in its entirety.

Different Ways of Implementing the Mobile Client Machines and Devices on the System Network of the Present Invention

[0098] In one illustrative embodiment, the enterprise-level system network is realized as a robust suite of hosted services delivered to Web-based client subsystems 1 using an application service provider (ASP) model. In this embodiment, the Web-enabled mobile application 12 can be realized using a web-browser application running on the operating system (OS) (e.g. Linux, Application IOS, etc) of a mobile computing device 11 to support online modes of system operation, only. However, it is understood that some or all of the services provided by the system network 1 can be accessed using Java clients, or a native client application, running on the operating system of a client computing device, to support both online and limited off-line modes of system operation. In such embodiments, the native mobile application 12 would have access to local memory (e.g. a local RDBMS) on the client device 11, accessible during off-line modes of operation to enable consumers to use certain or many of the system functions supported by the

system network during off-line/off-network modes of operation. It is also possible to store in the local RDBMS of the mobile computing device **11** most if not all relevant data collected by the mobile application for any particular fire-protection spray project, and to automatically synchronize the dataset for user's projects against the master datasets maintained in the system network database **9C1**, within the data center **8** shown in FIG. 4. This way, when using an native application, during off-line modes of operation, the user will be able to access and review relevant information regarding any building spray project, and make necessary decisions, even while off-line (i.e. not having access to the system network).

[0099] As shown and described herein, the system network **1** has been designed for several different kinds of user roles including, for example, but not limited to: (i) public and private property owners, residents, fire departments, local, county, state and federal officials; and (ii) wild fire suppression administrators, contractors, technicians et al registered on the system network. Depending on which role, for which the user requests registration, the system network will request different sets of registration information, including name of user, address, contact information, etc. In the case of a web-based responsive application on the mobile computing device **11**, once a user has successfully registered with the system network, the system network will automatically serve a native client GUI, or an HTML5 GUI, adapted for the registered user. Thereafter, when the user logs into the system network, using his/her account name and password, the system network will automatically generate and serve GUI screens described below for the role that the user has been registered with the system network.

[0100] In the illustrative embodiment, the client-side of the system network **1** can be realized as mobile web-browser application, or as a native application, each having a "responsive-design" and adapted to run on any client computing device (e.g. iPhone, iPad, Android or other Web-enabled computing device) **11** and designed for use by anyone interested in managing, monitoring and working to defend against the threat of wild fires.

Specification of the Mobile GPS-Tracked Anti-Fire (AF) Liquid Spraying System of the Present Invention

[0101] FIG. 6A shows a mobile GPS-tracked anti-fire (AF) liquid spraying system **20** supported on a set of wheels **20A**, having an integrated supply tank **20B** and rechargeable-battery operated electric spray pump **20C**, for deployment at private and public properties having building structures, for spraying the same with environmentally-clean anti-fire (AF) liquid using a spray nozzle assembly **20D** connected to the spray pump **20C** by way of a flexible **20E**.

[0102] FIG. 6B shows the GPS-tracked mobile anti-fire liquid spraying system **20** of FIG. 6A as comprising a number of subcomponents, namely: a GPS-tracked and remotely-monitored AF chemical liquid spray control subsystem **20F**; a micro-computing platform or subsystem **20G** interfaced with the GPS-tracked and remotely-monitored AF chemical liquid spray control subsystem **20F** by way of a system bus **20I**; and a wireless communication subsystem **20H** interfaced to the micro-computing platform **20G** via the system bus **20I**. As configured, the GPS-tracked mobile anti-fire liquid spraying system **20** enables and supports (i) the remote monitoring of the spraying of anti-fire (AF) chemical liquid from the system **20** when located at specific

GPS-indexed location coordinates, and (ii) the logging of all such GPS-indexed spray application operations, and recording the data transactions thereof within a local database maintained within the micro-computing platform **20G**, as well as in the remote network database **9C1** maintained at the data center **8** of the system network **1**.

[0103] As shown in FIG. 6B, the micro-computing platform **20G** comprises: data storage memory **20G1**; flash memory (firmware storage) **20G2**; a programmable micro-processor **20G3**; a general purpose I/O (GPIO) interface **20G4**; a GPS transceiver circuit/chip with matched antenna structure **20G5**; and the system bus **20I** which interfaces these components together and provides the necessary addressing, data and control signal pathways supported within the system **20**.

[0104] As shown in FIG. 6B, the wireless communication subsystem **20H** comprises: an RF-GSM modem transceiver **20H1**; a T/X amplifier **20H2** interfaced with the RF-GSM modem transceiver **20H1**; and a WIFI and Bluetooth wireless interfaces **20H3**.

[0105] As shown in FIG. 6B, the GPS-tracked and remotely-controllable anti-fire (AF) chemical liquid spray control subsystem **20F** comprises: anti-fire chemical liquid supply sensor(s) **20F1** installed in or on the anti-fire chemical liquid supply tank **20B** to produce an electrical signal indicative of the volume or percentage of the AF liquid supply tank containing AF chemical liquid at any instant in time, and providing such signals to the AF liquid spraying system control interface **20F4**; a power supply and controls **20F2** interfaced with the liquid pump spray subsystem **20C**, and also the AF liquid spraying system control interface **20F4**; manually-operated spray pump controls interface **20F3**, interfaced with the AF liquid spraying system control interface **20F4**; and the AF liquid spraying system control interface **20F4** interfaced with the micro-computing subsystem **20G**, via the system bus **20I**. The flash memory storage **20G2** contains microcode that represents a control program that runs on the microprocessor **20G3** and realizes the various GPS-specified AF chemical liquid spray control, monitoring, data logging and management functions supported by the system **20**.

[0106] In the preferred embodiment, the environmentally-clean anti-fire (AF) chemical liquid is preferably Hartindo AF31 Total Fire Inhibitor, developed by Hartindo Chemcatama Industri of Jakarta, Indonesia, and commercially-available from Newstar Chemicals (M) SDN. BHD of Selangor Darul Ehsan, Malaysia, <http://newstarchemicals.com/products.html>. When so treated, combustible products will prevent flames from spreading, and confine fire to the ignition source which can be readily extinguished, or go out by itself. In the presence of a flame, the chemical molecules in both dry and wet coatings, formed with Hartindo AF31 liquid, interferes with the free radicals (H⁺, OH⁻, O) involved in the free-radical chemical reactions within the combustion phase of a fire, and breaks these free-radical chemical reactions and extinguishes the fire's flames.

Specification of GPS-Tracked Manned or Autonomous Vehicle for Spraying Anti-Fire (AF) Liquid on Building and Ground Surfaces

[0107] FIG. 7A shows a mobile GPS-tracked manned or autonomous vehicle anti-fire (AF) liquid spray vehicle system **30** for spraying environmentally-clean anti-fire (AF) chemical liquid on exterior building surfaces and ground

surfaces in accordance with the principles of the present invention. As shown, the vehicle system 30 is supported on a set of wheels 30A driven by a propulsion drive subsystem 30 and navigated by GPS-guided navigation subsystem 30I, and carrying an integrated supply tank 30B with either rechargeable-battery-operated electric-motor driven spray pump, or gasoline/diesel or propane operated motor-driven spray pump, 30C, for deployment on private and public property parcels having building structures, for spraying the same with environmentally-clean anti-fire (AF) liquid using a spray nozzle assembly 30D connected to the spray pump 30C by way of a flexible hose 30E.

[0108] FIG. 7B shows the GPS-tracked mobile anti-fire liquid spraying system 30 of FIG. 7A as comprising a number of subcomponents, namely: a GPS-tracked and remotely-monitored AF chemical liquid spray control subsystem 30F; a micro-computing platform or subsystem 30G interfaced with the GPS-tracked and remotely-monitored AF chemical liquid spray control subsystem 30F by way of a system bus 30I; a wireless communication subsystem 30H interfaced to the micro-computing platform 30G via the system bus 30I; and a vehicular propulsion and navigation subsystem 30I employing a propulsion subsystem 30I1 and AI-driven or manually-driven navigation subsystem 30I2.

[0109] As configured in the illustrative embodiment, the GPS-tracked mobile anti-fire liquid spraying system 30 enables and supports (i) the remote monitoring of the spraying of anti-fire (AF) chemical liquid from the system 30 when located at specific GPS-indexed location coordinates, and (ii) the logging of all such GPS-indexed spray application operations, and recording the data transactions thereof within a local database maintained within the micro-computing platform 30G, as well as in the remote network database 9C1 maintained at the data center 8 of the system network 1.

[0110] As shown in FIG. 7B, the micro-computing platform 30G comprises: data storage memory 30G1; flash memory (firmware storage) 30G2; a programmable micro-processor 30G3; a general purpose I/O (GPIO) interface 30G4; a GPS transceiver circuit/chip with matched antenna structure 30G5; and the system bus 30I which interfaces these components together and provides the necessary addressing, data and control signal pathways supported within the system 30. As such, the micro-computing platform 30G is suitably configured to support and run a local control program 30G2-X on microprocessor 30G3 and memory architecture 30G1, 30G2 which is required and supported by the enterprise-level mobile application 12 and the suite of services supported by the system network 1 of the present invention.

[0111] As shown in FIG. 7B, the wireless communication subsystem 30H comprises: an RF-GSM modem transceiver 30H1; a T/X amplifier 30H2 interfaced with the RF-GSM modem transceiver 30H1; and a WIFI interface and a Bluetooth wireless interface 30H3 for interfacing with WIFI and Bluetooth data communication networks, respectively, in a manner known in the communication and computer networking art.

[0112] As shown in FIG. 7B, the GPS-tracked and remotely-controllable anti-fire (AF) chemical liquid spray control subsystem 30F comprises: anti-fire chemical liquid supply sensor(s) 30F1 installed in or on the anti-fire chemical liquid supply tank 30B to produce an electrical signal indicative of the volume or percentage of the AF liquid

supply tank containing AF chemical liquid at any instant in time, and providing such signals to the AF liquid spraying system control interface 30F4; a power supply and controls 30F2 interfaced with the liquid pump spray subsystem 30C, and also the AF liquid spraying system control interface 30F4; manually-operated spray pump controls interface 30F3, interfaced with the AF liquid spraying system control interface 30F4; and the AF liquid spraying system control interface 30F4 interfaced with the micro-computing subsystem 30G, via the system bus 30I. The flash memory storage 30G2 contains microcode for a control program that runs on the microprocessor 20G3 and realizes the various GPS-specified AF chemical liquid spray control, monitoring, data logging and management functions supported by the system 30.

Specification of GPS-Tracked Autonomously-Driven Drone System Adapted for Spraying Anti-Fire (AF) Liquid on Buildings and Ground Surfaces

[0113] FIG. 8A shows a mobile GPS-tracked unmanned airborne system (UAS) or drone 40 adapted for misting and spraying environmentally-clean anti-fire (AF) chemical liquid on exterior building surfaces and ground surfaces in accordance with the principles of the present invention.

[0114] As shown, the drone vehicle system 40 comprises: a lightweight airframe 40A0 supporting a propulsion subsystem 40I provided with a set of eight (8) electric-motor driven propellers 40A1-40A8, driven by electrical power supplied by a rechargeable battery module 409, and controlled and navigated by a GPS-guided navigation subsystem 40I2; an integrated supply tank 40B supported on the airframe 40A0, and connected to either rechargeable-battery-operated electric-motor driven spray pump, or gasoline/diesel or propane operated motor-driven spray pump, 40C, for deployment on private and public property parcels having building structures; a spray nozzle assembly 40D connected to the spray pump 40C by way of a flexible hose 40E, for misting and spraying the same with environmentally-clean anti-fire (AF) liquid under the control of GPS-specified coordinates defining its programmed flight path when operating to suppress or otherwise fight wild fires.

[0115] FIG. 8B shows the GPS-tracked anti-fire liquid spraying system 40 of FIG. 8A as comprising a number of subcomponents, namely: a GPS-tracked and remotely-monitored AF chemical liquid spray control subsystem 40F; a micro-computing platform or subsystem 40G interfaced with the GPS-tracked and remotely-monitored AF chemical liquid spray control subsystem 40F by way of a system bus 40I; a wireless communication subsystem 40H interfaced to the micro-computing platform 40G via the system bus 40I; and a vehicular propulsion and navigation subsystem 40I employing propulsion subsystem 40I1, and AI-driven or manually-driven navigation subsystem 40I2.

[0116] As configured in the illustrative embodiment, the GPS-tracked anti-fire liquid spraying system 40 enables and supports (i) the remote monitoring of the spraying of anti-fire (AF) chemical liquid from the system 40 when located at specific GPS-indexed location coordinates, and (ii) the logging of all such GPS-indexed spray application operations, and recording the data transactions thereof within a local database maintained within the micro-computing platform 40G, as well as in the remote network database 9C1 maintained at the data center 8 of the system network 1.

[0117] As shown in FIG. 8B, the micro-computing platform 40G comprises: data storage memory 40G1; flash memory (firmware storage) 40G2; a programmable micro-processor 40G3; a general purpose I/O (GPIO) interface 40G4; a GPS transceiver circuit/chip with matched antenna structure 40G5; and the system bus 40I which interfaces these components together and provides the necessary addressing, data and control signal pathways supported within the system 40. As such, the micro-computing platform 40G is suitably configured to support and run a local control program 40G2-X on microprocessor 40G3 and memory architecture 40G1, 40G2 which is required and supported by the enterprise-level mobile application 12 and the suite of services supported by the system network 1 of the present invention.

[0118] As shown in FIG. 8B, the wireless communication subsystem 30H comprises: an RF-GSM modem transceiver 40H1; a T/X amplifier 40H2 interfaced with the RF-GSM modem transceiver 40H1; and a WIFI interface and a Bluetooth wireless interface 40H3 for interfacing with WIFI and Bluetooth data communication networks, respectively, in a manner known in the communication and computer networking art.

[0119] As shown in FIG. 8B, the GPS-tracked and remotely-controllable anti-fire (AF) chemical liquid spray control subsystem 40F comprises: anti-fire chemical liquid supply sensor(s) 40F1 installed in or on the anti-fire chemical liquid supply tank 30B to produce an electrical signal indicative of the volume or percentage of the AF liquid supply tank containing AF chemical liquid at any instant in time, and providing such signals to the AF liquid spraying system control interface 40F4; a power supply and controls 40F2 interfaced with the liquid pump spray subsystem 40C, and also the AF liquid spraying system control interface 40F4; manually-operated spray pump controls interface 40F3, interfaced with the AF liquid spraying system control interface 30F4; and the AF liquid spraying system control interface 40F4 interfaced with the micro-computing subsystem 40G, via the system bus 40I. The flash memory storage 40G2 contains microcode for a control program that runs on the microprocessor 40G3 and realizes the various GPS-specified AF chemical liquid spray control, monitoring, data logging and management functions supported by the system 40.

Specification of GPS-Tracked Aircraft (i.e. Helicopter) for Spraying Anti-Fire (AF) Liquid on Ground Surfaces

[0120] FIG. 9A shows a mobile GPS-tracked manned aircraft (i.e. helicopter) system 50 adapted for misting and spraying environmentally-clean anti-fire (AF) chemical liquid on ground surfaces and over buildings in accordance with the principles of the present invention.

[0121] As shown, the aircraft system 50 comprises: a lightweight airframe 50A0 supporting a propulsion subsystem 50I provided with a set of axially-mounted helicopter blades 50A1-50A2 and 50A5, driven by combustion-engine and controlled and navigated by a GPS-guided navigation subsystem 50I2; an integrated supply tank 50B supported on the airframe 50A0, and connected to a gasoline/diesel operated motor-driven spray pump, 50C, for deployment on private and public property parcels having building structures; a spray nozzle assembly 50D connected to the spray pump 50C by way of a hose 50E, for misting and/or spraying the same with environmentally-clean anti-fire (AF) liquid

under the control of GPS-specified coordinates defining its programmed flight path when operating to suppress or otherwise fight wild fires.

[0122] FIG. 9B shows the GPS-tracked anti-fire liquid spraying system 50 of FIG. 9A as comprising a number of subcomponents, namely: a GPS-tracked and remotely-monitored AF chemical liquid spray control subsystem 50F; a micro-computing platform or subsystem 50G interfaced with the GPS-tracked and remotely-monitored AF chemical liquid spray control subsystem 50F by way of a system bus 50I; a wireless communication subsystem 50H interfaced to the micro-computing platform 50G via the system bus 50I; and a vehicular propulsion and navigation subsystem 50I employing propulsion subsystem 50I1, and AI-driven or manually-driven navigation subsystem 50I2.

[0123] As configured in the illustrative embodiment, the GPS-tracked anti-fire liquid spraying system 50 enables and supports (i) the remote monitoring of the spraying of anti-fire (AF) chemical liquid from the system 50 when located at specific GPS-indexed location coordinates, and (ii) the logging of all such GPS-indexed spray application operations, and recording the data transactions thereof within a local database maintained within the micro-computing platform 50G, as well as in the remote network database 9C1 maintained at the data center 8 of the system network 1.

[0124] As shown in FIG. 9B, the micro-computing platform 50G comprises: data storage memory 50G1; flash memory (firmware storage) 50G2; a programmable micro-processor 50G3; a general purpose I/O (GPIO) interface 50G4; a GPS transceiver circuit/chip with matched antenna structure 50G5; and the system bus 40I which interfaces these components together and provides the necessary addressing, data and control signal pathways supported within the system 50. As such, the micro-computing platform 50G is suitably configured to support and run a local control program 50G2-X on microprocessor 50G3 and memory architecture 50G1, 40G2 which is required and supported by the enterprise-level mobile application 12 and the suite of services supported by the system network 1 of the present invention.

[0125] As shown in FIG. 9B, the wireless communication subsystem 50H comprises: an RF-GSM modem transceiver 50H1; a T/X amplifier 50H2 interfaced with the RF-GSM modem transceiver 50H1; and a WIFI interface and a Bluetooth wireless interface 50H3 for interfacing with WIFI and Bluetooth data communication networks, respectively, in a manner known in the communication and computer networking art.

[0126] As shown in FIG. 9B, the GPS-tracked and remotely-controllable anti-fire (AF) chemical liquid spray control subsystem 50F comprises: anti-fire chemical liquid supply sensor(s) 50F1 installed in or on the anti-fire chemical liquid supply tank 50B to produce an electrical signal indicative of the volume or percentage of the AF liquid supply tank containing AF chemical liquid at any instant in time, and providing such signals to the AF liquid spraying system control interface 50F4; a power supply and controls 50F2 interfaced with the liquid pump spray subsystem 50C, and also the AF liquid spraying system control interface 50F4; manually-operated spray pump controls interface 50F3, interfaced with the AF liquid spraying system control interface 50F4; and the AF liquid spraying system control interface 50F4 interfaced with the micro-computing subsystem 50G, via the system bus 50I. The flash memory storage

50G2 contains microcode for a control program that runs on the microprocessor **50G3** and realizes the various GPS-specified AF chemical liquid spray control, monitoring, data logging and management functions supported by the system **50**.

Specification of GPS-Tracked Autonomously-Driven Aircraft for Spraying Anti-Fire (AF) Liquid on Building and Ground Surfaces

[0127] FIG. **10A** shows a mobile GPS-tracked manned all terrain vehicle (ATV) system **60** adapted for misting and spraying environmentally-clean anti-fire (AF) chemical liquid on ground surfaces in accordance with the principles of the present invention.

[0128] As shown, the aircraft system **60** comprises: a lightweight frame/chassis **60A0** supporting a propulsion subsystem **60I** provided with a set of wheels **60A1-60A4**, driven by combustion-engine, and controlled and navigated by a GPS-guided navigation subsystem **60I2**; an integrated supply tank **60B** supported on the frame **60A0**, and connected to a gasoline/diesel operated motor-driven spray pump, **60C**, for deployment on private and public property parcels; a spray nozzle assembly **60D** connected to the spray pump **60C** by way of a hose **60E**, for misting and/or spraying the same with environmentally-clean anti-fire (AF) liquid under the control of GPS-specified coordinates defining its programmed flight path when operating to suppress or otherwise fight wild fires.

[0129] FIG. **10B** shows the GPS-tracked anti-fire liquid spraying system **60** of FIG. **10A** as comprising a number of subcomponents, namely: a GPS-tracked and remotely-monitored AF chemical liquid spray control subsystem **60F**; a micro-computing platform or subsystem **60G** interfaced with the GPS-tracked and remotely-monitored AF chemical liquid spray control subsystem **60F** by way of a system bus **60I**; a wireless communication subsystem **60H** interfaced to the micro-computing platform **60G** via the system bus **50I**; and a vehicular propulsion and navigation subsystem **60I** employing propulsion subsystem **60I1**, and AI-driven or manually-driven navigation subsystem **60I2**.

[0130] As configured in the illustrative embodiment, the GPS-tracked anti-fire liquid spraying system **60** enables and supports (i) the remote monitoring of the spraying of anti-fire (AF) chemical liquid from the system **60** when located at specific GPS-indexed location coordinates, and (ii) the logging of all such GPS-indexed spray application operations, and recording the data transactions thereof within a local database maintained within the micro-computing platform **60G**, as well as in the remote network database **9C1** maintained at the data center **8** of the system network **1**.

[0131] As shown in FIG. **10B**, the micro-computing platform **60G** comprises: data storage memory **60G1**; flash memory (firmware storage) **60G2**; a programmable microprocessor **60G3**; a general purpose I/O (GPIO) interface **60G4**; a GPS transceiver circuit/chip with matched antenna structure **60G5**; and the system bus **60I** which interfaces these components together and provides the necessary addressing, data and control signal pathways supported within the system **60**. As such, the micro-computing platform **60G** is suitably configured to support and run a local control program **60G2-X** on microprocessor **60G3** and memory architecture **60G1**, **60G2** which is required and

supported by the enterprise-level mobile application **12** and the suite of services supported by the system network **1** of the present invention.

[0132] As shown in FIG. **10B**, the wireless communication subsystem **50H** comprises: an RF-GSM modem transceiver **60H1**; a T/X amplifier **60H2** interfaced with the RF-GSM modem transceiver **60H1**; and a WIFI interface and a Bluetooth wireless interface **60H3** for interfacing with WIFI and Bluetooth data communication networks, respectively, in a manner known in the communication and computer networking art.

[0133] As shown in FIG. **10B**, the GPS-tracked and remotely-controllable anti-fire (AF) chemical liquid spray control subsystem **60F** comprises: anti-fire chemical liquid supply sensor(s) **60F1** installed in or on the anti-fire chemical liquid supply tank **60B** to produce an electrical signal indicative of the volume or percentage of the AF liquid supply tank containing AF chemical liquid at any instant in time, and providing such signals to the AF liquid spraying system control interface **60F4**; a power supply and controls **60F2** interfaced with the liquid pump spray subsystem **60C**, and also the AF liquid spraying system control interface **60F4**; manually-operated spray pump controls interface **60F3**, interfaced with the AF liquid spraying system control interface **60F4**; and the AF liquid spraying system control interface **60F4** interfaced with the micro-computing subsystem **60G**, via the system bus **60I**. The flash memory storage **60G2** contains microcode for a control program that runs on the microprocessor **60G3** and realizes the various GPS-specified AF chemical liquid spray control, monitoring, data logging and management functions supported by the system **60**.

Specification of an Exemplary Network Database Schema for Supporting the System Network of the Present Invention and GPS-Specified Operations Involving the Spraying of Anti-Fire (AF) Liquid on GPS-Specified Ground, Property and Building Surfaces in Regions at Risk Prior to and During the Outbreak of Wild Fires

[0134] FIG. **11** shows an exemplary schema for the network database (RDBMS) **9C1** supported by the system network of the present invention, showing the primary enterprise level objects supported in the database tables created in the network database **9C** using the schema, and the relationships that are specified or indicated. This exemplary database schema is for supporting the system network of the present invention and gps-specified operations involving the spraying of anti-fire (AF) liquid on GPS-specified ground, property and building surfaces in regions at risk prior to and during the outbreak of wild fires.

[0135] As shown in FIG. **11**, the exemplary database schema for the system network **1** includes a number of high-level enterprise objects such as, for example: Users, with properties including User ID, Residence, Age, User Class (e.g. Wild Fire Management Administrator, Wild Fire Spray Applicator, Real Property Owner, Home Owner, Business Owner, Property Owner, Resident, etc.), and Pets; Real Property, with properties including Ownership/Lease, Location, Buildings, GPS Addresses, County, State; Vehicles, with properties such as Model, Year, Brand, Registered Owner; Water Crafts, with properties Model, ID # etc; Anti-Fire Chemical Liquid Supplies, with properties Manufacturer, Location, Quantity, Date Delivered; Anti-Fire (AF) Liquid Spraying Aircraft Systems, with properties Manufacturer, Model, ID#; Anti-Fire Liquid Spraying Ground

Systems, including Manufacturer, Model, ID#; Portable Anti-Fire Liquid Spraying Systems; Anti-Fire (AF) Chemical Liquid Spray Application Orders, including Location, ID #; Anti-Fire Chemical Liquid Spray Application Reports, with properties such as State, County, GPS Addresses; and Weather Data, with properties State, County, and GPS Addresses.

Specification of Exemplary Graphical User Interfaces Supported on the Mobile Application Deployed on System Network of the Present Invention, for the Purpose of Delivering the Various Services Supported on the System Network

[0136] FIG. 12 illustrates an exemplary wire-frame model of a graphical user interface (GUI) 13 of the mobile application 120 for use by registered users (e.g. property parcel owners, contractors and/or agents, and other stakeholders on the system network) to request and receive services supported by the system network of the present invention. As shown in this exemplary GUI screen 13, supports a number of pull-down menus under the titles: messages 13A, where the user can view messages sent via messaging services supported by the application; maps 13B, where wild fires have been identified and mapped, tracked and ranked in terms of risk to the user and associated property; and tasks 13C, where AF liquid spray tasks have been scheduled, have been completed, or are in progress, by the user.

[0137] FIG. 12A shows an exemplary graphical user interface supported by the mobile application 12 showing a user updating the registration profile as a task on the system network. The GUI screen is accessed and delivered to LCD screen of the mobile computing device 11 when the user selects the Tasks menu to display a menu of commands, and then selects the Update command from the command menu. During this service, the user can update various information items relating to the user profile, such as, name and address, contact information (e.g. email and SMS number), property parcel linked to ones profile, and GPS-tracked spray system deployed or assigned to the user and/or property parcel(s).

[0138] FIG. 12B shows an exemplary graphical user interface supported by the mobile application 12 showing a user receiving a message “notice of request to wild-fire spray protect a property parcel” (via email, SMS messaging and/or push-notifications) issued from the command center 19 to spray GPS-specified private property parcel(s) with clean anti-fire (AF) chemical liquid and registered GPS-tracked spray equipment.

[0139] FIG. 12C shows an exemplary graphical user interface supported by the mobile application 12 showing a user receiving a notice of order (via email, SMS messaging and/or push-notifications) to wild-fire spray-protect GPS-specified public property parcel(s) with clean anti-fire (AF) liquid to create and maintain a GPS-specified public firebreak (e.g. Firebreak No. 120).

[0140] FIG. 12D shows an exemplary graphical user interface supported by the mobile application showing a user requesting a refill of clean anti-fire (AF) chemical liquid for supply to GPS-specified spray equipment registered on the system network. The user selects the Tasks menu to display a set of commands, and then selects the Refill command from the displayed command menu. The user confirms the refill order and when ready selects the Send Request command from the display screen, sending the command to the

command center 19 and related data center 8 for processing and fulfillment. All operations are logged and tracked in the system network database 9C1 shown in FIG. 4.

[0141] In the illustrative embodiment, the mobile application 12 on mobile computing device 11 supports many functions to provide many services: (i) sends automatic notifications from the command center 19 to home/business owners with the mobile application 12, instructing them to spray their real property and home/building at certain times with anti-fire (AF) liquid contained in the tanks of GPS-tracked AF liquid spraying systems 20, 30, 40, 40, 50 and 60; (ii) automatically monitors consumption of sprayed AF-liquid and generate auto-replenish order (via its onboard GSM-circuits) so as to achieve compliance with the home/neighborhood spray defense program, and report AF chemical liquid levels in each home-owner tank; and (iii) shows status of wild fire risk in the region, and actions to be taken before wild fire outbreak.

[0142] FIG. 13 shows an exemplary graphical user interface 13' supported by the mobile application 12 configured for use by command center administrators to issue wild-fire protection orders, plan wild-fire protection tasks, generate wild-fire and protection reports, and send and receive messages to users on the system network, to carry out a wild fire suppression and management program in the region where the system network is deployed. As shown, GUI screen 13' supports a number of pull-down menus under the titles: Messages 13A', where project administrator and spray technicians can view messages sent via messaging services supported by the application; Maps 13B', where wild fires have been identified, tracked, and ranked in terms of risk to certain regions at a given moment in time; Planning 13C', wherein plans have been made to fight wild fires using the methods described in FIGS. 17 through 25B, status of specific plans, which one are in progress; and Reports 13D', where reports are issued to the mobile application 12 running on mobile client systems 11 in operable communication with the web, application and database servers 9A, 9B and 9C at the data center 8, supported by the system network 1.

[0143] FIG. 13A shows an exemplary graphical user interface supported by the mobile application configured for use by command center administrators to issue wild-fire protection orders using the system network of the present invention. As shown, the user selects the Planning menu and displays a set of planning commands, and then selects the Property command, where the user is then giving to choice to select one or more parcels of property in a given region, and then select an Action (e.g. Wild Fire Spray Protect). The user selects the property parcel(s), and then the required Action (i.e. Wild Fire Spray Protect), and Order is set up for the command center action. When the command center selects execute from the menu, the system network issues the order and sends notice of orders to all property parcel owners or agents to oversee the immediate spraying of the GPS-specified property parcels with clean anti-fire (AF) chemical liquid supply to the property owners or agents as the case may be.

[0144] FIG. 13B shows an exemplary graphical user interface supported by the mobile application 12 configured for use by command center administrators to issue wild-fire protection orders involving the creation and maintenance of a clean AF-based chemical firebreak, as illustrated in FIG. 18, for example, using the methods of the present invention

described herein. As shown, the administrator selects the Planning menu, and displays a menu of Planning commands, from which the user selects Firebreaks. In the case example shown in FIG. 13B, the administrator issues an Order to apply or rather practice the dual-region clean AF chemical firebreak method illustrated in FIG. 18, at GPS-specified coordinates GPS LAT-X/LONG-Y using AF chemical liquid misting and spraying airborne operations. As shown the order will specify the deployment of specific GPS-tracked AF spray vehicle systems, and identify them by system ID #. The order may also identify or request users (e.g. pilots) assigned to the AF chemical firebreak project/task.

[0145] FIG. 13C shows an exemplary graphical user interface supported by mobile application 12 configured for use by command center administrators to order the creation and/or maintenance of a GPS-specified clean AF-based chemical firebreak on one or more public/private property parcels. As shown, the administrator selects the Planning menu, and displays a menu of Planning commands, from which the user selects Firebreaks. In the case example shown in FIG. 13C, the administrator issues an Order to practice a the Wild Fire Spray Protect Method alongside one or more parcels of public property, which may be a long strip of land/brush alongside or near a highway. The method may be the AF chemical firebreak method as illustrated in the FIG. 22 and described in FIGS. 23A, 23B and 23C, at GPS-specified coordinates GPS LAT-X/LONG-Y using ground-based AF chemical liquid spraying operations. As shown, the order will specify the deployment of specific GPS-tracked AF spray vehicle systems, and identify them by system ID #. The order may also identify or request users (e.g. drivers) assigned to the AF chemical firebreak project/task. Alternatively, other methods disclosed in FIGS. 20 through 21C and FIGS. 24, 25A and 25B.

[0146] FIG. 13D shows an exemplary graphical user interface for mobile application configured used by command center administrators to receive messages from users including property owners and contractors, requesting refills for clean anti-fire (AF) chemical liquid for GPS-specified spray system equipment. While the system network 1 AF chemical liquid refills

[0147] FIG. 14 shows an exemplary fire hazard severity zone (FHSZ) map generated by the CAF FIRE™ System in state responsibility areas of the State of California. Such maps can be used by the system network 1 to inform the strategic application of environmentally-clean anti-fire (AF) liquid spray using the system network of the present invention. Such maps also can be displayed on the mobile application 12 to provide greater awareness of risks created by wild fires in a specific region, at certain moments in time.

Specification of an Exemplary Anti-Fire (AF) Spray Protection Map Generated by the System Network of the Present Invention

[0148] FIG. 15 shows an exemplary GPS-specified anti-fire (AF) chemical liquid spray protection map generated by the system network 1, showing properties, houses and buildings that were sprayed, and not-sprayed, with state/county-issued anti-fire liquid as of report date, 15 Dec. 2017. The system network will periodically update these AF chemical liquid spray protection maps (e.g. every 5 minutes or less) for display to users and neighbors to see whose property/land parcels and homes/building have been spray protected with anti-fire (AF) chemical liquid (e.g. Hartindo

AF31 anti-fire chemical liquid), and whose parcels and home/buildings have not been AF-spray protected against wild fires, so that they can or may volunteer to lend a helping hand in spray protecting their neighbors properties as time and anti-fire chemical supplies allow, to provide a stronger defense against one or more wild fires raging towards their neighborhood.

[0149] In accordance with the principles of the present invention, the application servers 9B supported by the system network 1 will automatically generate anti-fire (AF) chemical liquid spray-protection task reports, as illustrated in FIG. 16, based on the analysis of spray-protection maps as shown in FIG. 15, and based on many other kinds of intelligence collected by the system, and analyzed by human analysts, as well as artificial intelligence (AI) expert systems. Based on such automated intelligence efforts, the application servers 9B will generate periodically, and as needed, AF chemical liquid (AFCL) Spray Command Program files containing GPS/Time-Frame-indexed commands and instructions that are wirelessly transmitted to assigned GPS-tracked anti-fire (AF) chemical liquid spraying systems 30, 40, 50 and 60, so that the operators of such GPS-tracked AF liquid spraying systems will know when and where to mist and/or spray AF chemical liquid over and one certain GPS-specified properties, in their effort to defend against the threat of wild fires.

[0150] The AFCL Spray Command Program files, containing GPS-indexed commands and instructions, generated by the application servers 9B are transmitted over the system network 1 to the numerous deployed GPS-tracked AF liquid spraying systems 30, 40, 50 and 60, so as to orchestrate and choreograph the spray application of clean anti-fire (AF) chemical liquid over GPS-specified properties, before and during the presence of wild fires, so as to implement an orchestrated strategic and collective defense against wild fires that break out for various reasons, threatening states, counties, towns, neighborhoods homes, business, and human and animal life.

[0151] In some embodiments, the application servers 9B will generate and issue AFCL Spray Command Program files that are transmitted to specific GPS-tracked AF liquid spraying systems 30, 40, 50 and 60, and containing automated instructions (i.e. commands) on when and where (i.e. in terms of time frame and GPS-specified coordinates) the GPS-tracked AF liquid spraying systems should automatically apply, via spraying operations, clean AF chemical liquid on GPS-specified property during their course of movement over land. During such spraying operations, the system network 1 will automatically meter, dispense and log how much clean AF chemical liquid has been sprayed over and on certain GPS-specified properties. Real-time wind-speed measurements can be made and used to compensate for spraying operations in real-time, as may be required under certain weather conditions.

[0152] In other embodiments, the application servers 9B will generate and issue AFCL Spray Command Program files that are transmitted to other GPS-tracked AF liquid spraying systems 30, 40, 50 and 60, providing automated instructions (i.e. commands) on when and where the GPS-tracked AF liquid spraying systems should spray-apply clean AF chemical liquid on GPS-specified property during course of movement over land, but allowing the human operator to override such spraying instructions, and compensate and ensure greater accuracy, using human operator skill and

judgment during spraying operations. While such spraying operations, the system will automatically meter, log and record all dispensed AF chemical liquid sprayed over and over certain GPS-specified properties under the supervision and control of the human operator.

Specification of an Exemplary Anti-Fire Spray Protection Task Report Generated by the System of the Present Invention

[0153] FIG. 16 shows an exemplary GPS-specified anti-fire spray protection task report generated by the system network 1 for state/county xxx on 15 Dec. 2017, indicating which properties on what streets, in what town, county, state, requires the reapplication of AF chemical liquid spray treatment in view of factors such as weather (e.g. rainfall, sunlight) and passage of time since last spray application. Such task reports will be transmitted by the command center 19 to registered users, along with an SMS and/or email message to attend to the AF spray task, so the requested user will promptly spray protect their land parcels and home with clean AF chemical liquid, as conditions require or suggest, using the mobile/portable GPS-tracked AF liquid spraying system 20 assigned to the property owner, and deployed over the system network 1.

[0154] As contracted AF-spray operators, and home owners alike, protect properties and homes using the GPS-tracked AF liquid spraying systems (20, 30, 40, 50 and 60), the system network 1 automatically receives GSM or other RF-based signals transmitted from the GPS-tracked anti-fire (AF) chemical liquid spraying systems, indicating that certain amounts of AF chemical liquid has been dispensed and sprayed from the system onto GPS-specified property. Notably, the amounts of AF chemical liquid dispensed and sprayed from the system over and onto GPS-specified property should closely match the amounts requested in the task report transmitted to the user, to achieve the AF spray protection task directed by AI-driven management processes supported by the wild fire suppression system network of the present invention.

Specification of New and Improved Wild Fire Suppression Methods in Accordance with Principles of the Present Invention

[0155] Having described the various GPS-tracked anti-fire (AF) chemical liquid spraying systems of the illustrative embodiments 20, 30, 40, 50 and 60, shown in the Figure Drawings, and the various functions supported by the mobile application 12 supported by the data center 8 of the system network 1, it is appropriate at this juncture to now described the various new and improved wild fire suppression methods in accordance with principles of the present invention, each involving GPS-guided spray application of clean anti-fire (AF) chemical liquid having a chemistry that works to break a wild fire by interfering with the free-radicals produced during the combustion phase of a ranging wild fire. The benefits and advantages provided by such new and improved methods will become apparent hereinafter.

Specification of a Method of Suppressing a Wild Fire Raging Across a Region of Land in the Direction of the Prevailing Winds

[0156] FIG. 17 shows a plan view of a wild fire 70 emerging from a forest region 71A and approaching a neighboring town 72 surrounded by other forest regions

71B, 71B and 71C, and moving in the direction determined by prevailing winds, indicated by a pair of bold arrows. This example closely resembles the pathway of many wild fires recently destroying countless acres of land (i.e. real property) in the State of California in 2017.

[0157] FIG. 18 illustrates the various steps involved in carrying out the method of suppressing a wild fire raging across a region of land. Specifically, the method involves forming a multi-stage anti-fire chemical fire-break system illustrated in FIG. 18 using the remotely-managed GPS-controlled application of both anti-fire (AF) liquid mist streams and AF chemical liquid spray streams from ground and air based GPS-tracked anti-fire (AF) liquid spray vehicles, as illustrated in FIGS. 7A, 7B and 9A, 9B, for example.

[0158] As illustrated in FIG. 18, the method generally involves: (a) applying, prior to the wild fire reaching the specified target region of land 74, a low-density anti-fire (AF) liquid mist stream in advance of the wild fire 75 so as to form a fire stall region 76, while providing a non-treated region 77 of sufficient size between the front of the wild fire 75 approaching the target region of land 73 and the fire stall region 76; and (b) applying a high-density anti-fire (AF) liquid spray stream in advance of the wild fire 75 to form a fire break region 74 beyond and contiguous with the fire stall region 76, and also continuous with the target region 73 to be protected from the wild fire.

[0159] As illustrated in FIG. 18, the fire stall region 76 is formed before the wild fire reaches the fire stall region 76. The fire stall region 76 operates to reduce the free-radical chemical reactions raging in the wild fire 75. This fire stall region 76 helps to reduce the destructive energy of the wild fire by the time the wild fire reaches the fire break region 74, and enabling the fire break region 74 to operate and significantly break the free radical chemical reactions in the wild fire 75 when the wild fire reaches the fire break region 74. This helps to suppress the wild fire 75 and protect the target region of land 73.

[0160] FIGS. 19A and 19B describe the method of suppressing a wild fire raging towards a target region of land 73 (and beyond) in a direction determined by prevailing winds and other environmental and weather factors, as illustrated in FIG. 18. Typically, the system used to practice this method of the present invention will employ a centralized GPS-indexed real-property/land database system 7 shown in FIG. 4 containing GPS-indexed maps of all land regions under management and fire-protection, developed using methods, equipment and services known in the GPS mapping art. Such GPS-indexed maps will contain the GPS coordinates for the vertices of each and every parcel in any given state, county and town in the country in which system is deployed. As shown in FIG. 4, this central GPS-indexed real property database 7 will be operably connected to the TCP/IP infrastructure 10 of the Internet, and accessible by system network 1 of the present invention.

[0161] As indicated at Block A in FIG. 19A, prior to the wild fire reaching the specified target region of land, a GPS-tracked AF spray vehicle 50 as shown for example in FIG. 9A applies a low-density anti-fire (AF) liquid mist 80 in advance of the wild fire so as to form a fire stall region 76 while providing a non-treated region 77 of sufficient size between the front of the wild fire approaching the target region of land 73 and the fire stall region 76. The fire stall region 76 is formed by a first GPS-guided aircraft system

flying over the fire stall region during multiple passes and applying the low-density AF chemical liquid mist **80** over the fire stall region **76**. The non-treated region **77** is defined by a first set of GPS coordinates $\{\text{GPS}_1(x,y)\}$ and, the fire stall region **76** is defined by a second set of GPS coordinates $\{\text{GPS}_2(x,y)\}$. Each of these regions are mapped out using global positioning system (GPS) methods, the GPS-indexed land database system **7**, drone-type aircraft systems as shown in FIG. **8A**, and space-based land-imaging satellites **14** having multi-spectral imaging capabilities, and operably connected to the infrastructure of the Internet. When used alone and/or together, these systems are capable of capturing real-time intelligence on the location and spread of a particular wild fire, its direction of propagation, intensity and other attributes. This captured data is provided to application servers in the data center **8** which, in turn, generate GPS coordinates determining the planned pathways of the GPS-traced AF chemical liquid spraying/misting aircraft systems, to provide the anti-fire protection over the GPS-indexed fire stall region **76** and GPS-specified non-treated region **75**, as described in greater detail below.

[0162] As indicated at Block B in FIG. **19A**, a second GPS-tracked AF spray vehicle as shown in FIG. **9A** applies a high-density anti-fire (AF) liquid spray **81** over the land in advance of the wild fire to form a GPS-specified fire break region **74** beyond and contiguous with the GPS-specified fire stall region **76**. The fire break region **74** is formed by the second GPS-guided aircraft flying over the fire break region **74** during multiple passes and applying the high-density AF chemical liquid spray **81** over the fire break region **74**. The fire break region **74** is defined by a third set of GPS coordinates $\{\text{GPS}_3(x,y)\}$ mapped out using global positioning system (GPS) methods, the GPS-indexed land database system **7**, drone-type aircraft systems as shown in FIG. **8A**, and/or space-based land-imaging satellites **14** having multi-spectral imaging capabilities, and operably connected to the infrastructure of the Internet. When used alone and/or together, these systems are capable of capturing real-time intelligence on the location and spread of a particular wild fire, its direction of propagation, intensity and other attributes. This captured data is provided to application servers in the data center **8** which, in turn, generate GPS coordinates determining the planned pathways of the GPS-traced AF chemical liquid spraying/misting aircraft systems, to provide the anti-fire protection over GPS-specified fire break region **74**, as described in greater detail below.

[0163] As indicated at Block C in FIG. **19B**, the fire stall region **76** is formed before the wild fire **75** reaches the fire stall region **76**, and operates to reduce the free-radical chemical reactions raging in the wild fire so as to reduce the destructive energy of the wild fire by the time the wild fire **75** reaches the fire break region **74**, and enabling the fire break region **74** to operate and significantly break the free radical chemical reactions in the wild fire **75** when the wild fire reaches the fire break region **74**, and thereby suppress the wild fire **75** and protect the target region of land **73** and beyond.

Specification of a Method of Reducing the Risks of Damage to Private Property Due to Wild Fires by Managed Application of Anti-Fire (AF) Liquid Spray

[0164] FIG. **20** illustrates a method of reducing the risks of damage to private property due to wild fires by managed application of anti-fire (AF) liquid spray. FIGS. **21A**, **21B**

and **21C** illustrates a method of reducing the risks of damage to private property due to wild fires by managed application of anti-fire (AF) liquid spray. Typically, this method is carried out using the system network of FIG. **4** and any one or more of the GPS-tracked anti-fire (AF) liquid spray vehicle systems **14A-14D** represented in FIG. **4** and shown in FIGS. **6A**, **6B**, **7A**, **7B**, **8A**, **8B**, **9A**, **9B**, and **10A**, **10B**. **[0165]** As indicated at Block A in FIG. **21A**, the system registers each GPS-specified parcel of private real property in a specified County and State, which may or may not have buildings constructed thereon, and identifying the owner and tenants, as well as all pets, vehicles and watercrafts associated with the registered parcel of private property. Typically, the system will request the address of the property parcel, and will automatically determine its GPS coordinates that specify the vertices of the parcel using databases, and data processing methods, equipment and services, known in the GPS mapping art.

[0166] As indicated at Block B in FIG. **21A**, the system collects intelligence relating to the County, risks of wild fires in the surrounding region, and historical data maintained in a network database, and generating GPS-specified anti-fire (AF) spray protection maps and task reports for execution.

[0167] As indicated at Block C in FIG. **21A**, an AF chemical liquid spraying system is provided to a GPS-specified location for spraying one or more registered parcels of private property with AF chemical liquid spray.

[0168] As indicated at Block D in FIG. **21A**, a supply of AF chemical liquid spray is provided to the GPS-specified location of the AF chemical liquid spraying system.

[0169] As indicated at Block E in FIG. **21A**, the AF chemical liquid spraying system is provided with the supply of AF chemical liquid.

[0170] As indicated at Block F in FIG. **21B**, based on the GPS-specified anti-fire (AF) spray protection maps and task reports, the system issues orders to the private property owner, or its contractor, to apply AF chemical liquid spray on the private property using the AF chemical liquid spraying system.

[0171] As indicated at Block G in FIG. **21B**, the private property owner executes the order and applies AF chemical liquid spray on the private property using the AF chemical liquid spraying system, and the system remotely monitors the consumption and application of AF chemical liquid at the private property on a given time and date, and automatically records the transaction in the network database **9C** prior to the arrival and presence of wild fire in the region.

[0172] As indicated at Block H in FIG. **21B**, the system updated the records in the network database associated with each application of AF chemical liquid spray on a GPS-specified parcel of private property.

[0173] As indicated at Block I in FIG. **21B**, the system scheduled the next application of AF chemical liquid spray on the GPS-specified parcel of private property, factoring weather conditions and the passage of time.

[0174] As indicated at Block J in FIG. **21B**, the system issues another order to the GPS-specified parcel of private property to re-apply AF chemical liquid spray on the private property to maintain active wild fire protection.

[0175] As indicated at Block K in FIG. **21C**, the property owner executes (i.e. carries out) the order to reapply AF chemical liquid spray on the parcel of private property using the AF chemical liquid spraying system, and the system remotely monitors the application of AF chemical liquid at

the private property on a given time and date, and records this transaction in the network database 9C.

[0176] As indicated at Block L in FIG. 21C, the system updates records on AF chemical liquid spray application in the network database 9C associated with reapplication of AF chemical liquid on the parcel of private property.

[0177] As indicated at Block M in FIG. 21C, the system schedules the next application of AF chemical liquid spray on the parcel of private property, factoring weather conditions and the passage of time.

Specification of a Method of Reducing the Risks of Damage to Public Property Due to Wild Fires, by Managed Spray Application of AF Liquid to Ground Cover and Building Surfaces Prior to the Arrival of Wild Fires

[0178] FIG. 22 illustrates a method of reducing the risks of damage to public property due to wild fires, by managed spray application of AF chemical liquid to ground cover and building surfaces prior to the arrival of wild fires. FIGS. 23A, 23B and 23C illustrate a method of reducing the risks of damage to public property due to wild fires by managed application of anti-fire (AF) liquid spray. Typically, this method is carried out using the system network of FIG. 4 and any one or more of the GPS-tracked anti-fire (AF) liquid spray vehicle systems 14A-14D represented in FIG. 4 and shown in FIGS. 6A, 6B, 7A, 7B, 8A, 8B, 9A, 9B, and 10A, 10B.

[0179] As indicated at Block A in FIG. 23A, each GPS-specified parcel of public real property in a specified County and State is registered with the system. Such parcels of property may or may not have buildings constructed thereon. As part of registration with the system network 1, supported by the network database 9C, it is necessary to identify the owner and tenants, as well as all pets, vehicles and watercrafts associated with the registered parcel of public property. Typically, the system will request the address of the property parcel, and will automatically determine its GPS coordinates that specify the vertices of the parcel using databases, and data processing methods, equipment and services, known in the GPS mapping art.

[0180] As indicated at Block B in FIG. 23A, the system collects various kinds of intelligence relating to the County, risks of wild fires in the surrounding region, and historical weather and related data maintained in a network database 9C, and generates GPS-specified anti-fire (AF) spray protection maps and task reports for review and execution, along with GPS-specified spray plans (e.g. flight plans) for GPS-tracked anti-fire (AF) liquid spray vehicle systems 30 and 60, and GPS-specified spray plans.

[0181] As indicated at Block C in FIG. 23A an AF chemical liquid spraying system is provided to a GPS-specified location for spraying one or more registered parcels of public property with AF chemical liquid spray.

[0182] As indicated at Block D in FIG. 23A, a supply of AF chemical liquid spray is provided to the registered location of the AF chemical liquid spraying system.

[0183] As indicated at Block E in FIG. 23A, the AF chemical liquid spraying system is filled with the provided supply of AF chemical liquid.

[0184] As indicated at Block F in FIG. 23B, based on the anti-fire (AF) spray protection maps and task reports, the system issues orders to the public property owner, or its contractor, to apply AF chemical liquid spray on the public property using the AF chemical liquid spraying system 60.

[0185] As indicated at Block G in FIG. 23B, the public property owner executes the order and applies AF chemical liquid spray on the public property using the AF chemical liquid spraying system, and the system remotely monitors the consumption and application of AF chemical liquid at the public property on a given time and date, and automatically records the transaction in the network database prior to the presence of wild fire in the region.

[0186] As indicated at Block H in FIG. 23B, the system updates records in the network database 9C associated with each application of AF chemical liquid spray on a GPS-specified parcel of public property.

[0187] As indicated at Block I in FIG. 23B, the system schedules the next application of AF chemical liquid spray on the GPS-specified parcel of public property, factoring weather conditions and the passage of time.

[0188] As indicated at Block J in FIG. 23B, the system issues another order to the GPS-specified parcels of public property to re-apply AF chemical liquid spray on the public property to maintain active fire protection.

[0189] As indicated at Block K in FIG. 23C, the property owner executes the order to reapply AF chemical liquid spray on the GPS-specified parcels of public property using the AF chemical liquid spraying system, and the system remotely monitors the application of AF chemical liquid at the public property on a given time and date, and records this transaction in the network database 9C.

[0190] As indicated at Block L in FIG. 23C, the system updates records on AF chemical liquid spray application in the network database 9C associated with reapplication of AF chemical liquid on the GPS-specified parcels of public property.

[0191] As indicated at Block M in FIG. 23C, the system schedules the next application of AF chemical liquid spray on the GPS-specified parcels of public property, factoring weather conditions and the passage of time.

Specification of a Method of Remotely Managing the Application of Anti-Fire (AF) Liquid Spray to Ground Cover and Buildings so as to Reduce the Risks of Damage Due to Wild Fires

[0192] FIG. 24 is a graphical illustration showing a method of remotely managing the application of anti-fire (AF) liquid spray to ground cover and buildings so as to reduce the risks of damage due to wild fires. FIGS. 25A and 25B describes the high level steps carried out by the method in FIG. 24 to reduce the risks of damage due to wild fires. Typically, this method is carried out using the system network of FIG. 4 and any one or more of the GPS-tracked anti-fire (AF) chemical liquid spray vehicle systems 14A-14D represented in FIG. 4 and shown in FIGS. 6A, 6B, 7A, 7B, 8A, 8B, 9A, 9B, and 10A, 10B.

[0193] As indicated at Block A in FIG. 25A, the system registers each GPS-specified parcel of real property in a specified County and State, which may or may not have buildings constructed thereon, and identifying the owner and tenants, as well as all pets, vehicles and water crafts associated with the registered parcel of real property. Typically, the system will request the address of the property parcel, and will automatically determine (or estimate) its GPS coordinates that specify the vertices of the parcels using databases, and data processing methods, equipment and services, known in the GPS mapping art. The GPS address

of each parcel will be stored in the centralized GPS-indexed land database system **7** shown in FIG. **4**

[0194] As indicated at Block B in FIG. **25A**, the system collects intelligence relating to the County, risks of wild fires in the surrounding region, and historical data maintained in a network database, and generates GPS-specified anti-fire (AF) spray protection maps and task reports for execution.

[0195] As indicated at Block C in FIG. **25A**, an AF chemical liquid spraying system is provided to a GPS-specified location for spraying the GPS-specified parcels of real property with AF chemical liquid spray.

[0196] As indicated at Block D in FIG. **25A**, a supply of AF chemical liquid spray is provided to the GPS-specified location of the AF chemical liquid spraying system.

[0197] As indicated at Block E in FIG. **25A**, the AF chemical liquid spraying system is filled with the provided supply of AF chemical liquid.

[0198] As indicated at Block F in FIG. **25B**, prior to the arrival of a wild fire to the region, and based on the anti-fire (AF) spray protection maps generated by the system, the system issues a request to property owners, or their registered contractors, to apply AF chemical liquid spray on GPS-specified properties using deployed AF chemical liquid spraying systems.

[0199] As indicated at Block G in FIG. **25B**, in response to the issued request, the property owner or contractor thereof applies AF chemical liquid spray on the real property using the AF chemical liquid spraying system, and the system remotely monitors the consumption and application of the AF chemical liquid on the property on a given date, and automatically records the transaction in the network database.

[0200] As indicated at Block H in FIG. **25B**, the system updates records in the network database associated with each application of AF chemical liquid spray on one or more GPS-specified parcels of real property.

[0201] In the illustrative embodiment, Hartindo AF31 Total Fire Inhibitor (from Hartindo Chemicatama Industri of Jakarta, Indonesia <http://hartindo.co.id>, or its distributor Newstar Chemicals of Malaysia) is used as a clean anti-fire (AF) chemical liquid when practicing the present invention. A liquid dye of a preferred color from Sun Chemical Corporation <http://www.sunchemical.com> can be added to Hartindo AF31 liquid to help visually track where AF chemical liquid has been sprayed during the method of wild fire suppression. However, in some applications, it may be desired to maintain the AF chemical liquid in a clear state, and not employ a colorant. Also, the clinging agent in this AF chemical liquid formulation (i.e. Hartindo AF31 liquid) will enable its chemical molecules to cling to the surface of combustible materials, including vegetation, so that it is quick to defend and break the combustion phase of fires (i.e. interfere with the free radicals driving combustion).

Specification of the Method of Qualifying Real Property for Reduced Property Insurance, Based on Verified Spray-Based Clean Anti-Fire (AF) Chemical Liquid Treatment, Prior to Presence of Wild Fires, Using the System Network of the Present Invention

[0202] FIG. **26** describes the method of qualifying real property for reduced property insurance, based on verified spray-based clean anti-fire (AF) chemical liquid treatment

prior to presence of wild fires, using the system network of the present invention **1** described in great technical detail hereinabove.

[0203] As indicated at Block A in FIG. **26**, a clean anti-fire (AF) chemical liquid is periodically sprayed over the exterior surfaces of a wood-framed building and surrounding real property to provide Class-A fire-protection to the property in the face of an approaching wild fire.

[0204] As indicated at Block B in FIG. **26**, the spray-based Class-A fire protection treatment is verified and documented using captured GPS-coordinates and time/date stamping data generated by the GPS-tracked AF-liquid spraying system (**20**, **30**, **40**, **50** and/or **60**) deployed on the system network **1** and used to apply fire protection treatment.

[0205] As indicated at Block C in FIG. **26**, the spray protection treatment data, generated by the GPS-tracked anti-fire (AF) liquid spraying system used to apply the spray-based class-a fire protection treatment, is wirelessly transmitted to the central network database, to update the central network database **9C1** on the system network.

[0206] As indicated at Block D in FIG. **26**, a company underwriting property insurance for the wood-framed building accesses the central network database **9C1** on the system network **1**, to verify the database records maintained for each spray-based Class-A fire-protection treatment relating to the property and any wood-framed buildings thereon, to qualify the property/building owner for lower property insurance premiums, based on the verified Class-A fire-protection status of the sprayed property/building.

[0207] As indicated at Block E in FIG. **26**, upon the outbreak of a wild fire about the insured wood-framed building/property, the local fire departments can use the mobile application **12** designed to command center administrators, a provided with suitable filters and modifications, to instantly and remotely assess the central network database **9C1**, so as to quickly determine and identify the Class-A fire-protected status of the property and any wood-framed buildings thereon by virtue of timely clean anti-fire (AF) chemical liquid application on the property, and advise fireman fighting and managing wild fires that the Property has been properly defended against wild fire.

[0208] By virtue of this method of the presence invention described above, it is now possible to better protect real property and buildings against wild fires when using the system network of the present invention **1**, and at the same time, for property insurance underwriters to financially encourage and incentivize property owners to comply with the innovative clean anti-fire (AF) chemical liquid spray programs disclosed and taught herein that improve the safety and defense of neighborhoods against the destructive energy carried by wild fires.

Method of and Apparatus for Applying Fire and Smoke Inhibiting Slurry Compositions on Ground Surfaces Before the Incidence of Wild-Fires, and Also Thereafter, Upon Smoldering Ambers and Ashes to Reduce Smoke and Suppress Fire Re-Ignition

[0209] FIGS. **27A**, **27B** and **27C** show the clean fire and smoke inhibiting slurry spray application vehicle **90** carrying a high-capacity (e.g. 3000 gallon) stainless steel mixing tank **93** with an integrated agitator mechanism (e.g. motor driven mixing paddles) **94**, and a hydraulic pumping apparatus and spray nozzle **101** for mixing and spraying the environmentally-clean aqueous-based clean fire and smoke

inhibiting slurry **102** (i) on ground surfaces to create CFIC-based fire breaks (**105**) around regions to be protected from wildfires as illustrated in FIGS. **30** and **31**, (ii) to cover smoldering ambers and ash after the present of wildfires to reduce toxic waster water runoff and smoke production as shown in FIG. **32**, and (iii) on burning fires destroying buildings as well as outdoor combustion material as shown in FIG. **33**.

[0210] FIG. **28** shows the clan fire and smoke inhibiting slurry spray application vehicle **90** comprising: a mobile slurry mixing and spray vehicle chassis **91** having a propulsion and transport subsystem **92**, with a vehicle chassis supporting a high-capacity (e.g. 3000 gallon) stainless steel mixing tank **93**, with an integrated agitator mechanism (e.g. motor driven mixing paddles) **94**, and having a filling chute **93A** through which slurry ingredients (e.g. thermally processed wood fibers, cellulose fibers, wetting agents, tacking agents **96**, and a supply of clean fire inhibiting chemical **97** (e.g. Hartindo AF21 clean anti-fire inhibiting chemical liquid); a water pumping subsystem **99** for pumping water **98** from an external source into the mixing tank **93** to blend with the chemicals and fiber material **96** and CFIC material **97**, and produce an environmentally-clean fire and smoke inhibiting mixture **102**; a hydraulic pumping apparatus and spray nozzle **101**, for mixing and spraying the clean aqueous-based clean fire and smoke inhibiting slurry mixture **102** (i) on ground surfaces to create CFIC-based fire breaks around regions to be protected from wildfires, (ii) over smoldering ambers and ash after the present of wildfires to reduce toxic waster water runoff and smoke production, and (iii) on active burning fires in buildings and/or burning land and brush. As shown, the vehicle system **90** includes A GPS receiver and controls **100** for controlling apparatus specified by **91**, **92**, **93**, **94**, **98**, and **101**. The system **90** also includes a second CFIC liquid tank **112** for storing a secondary CFIC liquid (e.g. Hartindo AF31 anti-fire inhibiting liquid) **113**, and supplying an air-less spray system **111** for spraying AF31 CFIC liquid **113** using a spray nozzle applicator **111A**. The spray applicator **112** can be mounted on the vehicle **90**, alongside or in tandem with primary slurry spray nozzle **101A**, or it can be via connected to a reel of hose for application of CFIC AF31 **113** to the surface of the slurry coating **102** after it has been applied to the ground surface. Preferably, AF31 spray **113** will be provided with a colored dye to assist in spray application over the fire and smoke inhibiting slurry **102**. By providing a vehicle **90** with two tanks, one tank **93** containing the slurry mixture **102**, and the other tank **112** containing a CFIC liquid **113**, the system **90** has an added capacity to supress fire and smoke created by wildfires, and other sources of fire.

[0211] FIG. **29** describes the method of applying fire and smoke inhibiting slurry compositions of the present invention on ground surfaces before the incidence of wild-fires, and also thereafter, upon smoldering ambers and ashes to reduce smoke and suppress fire re-ignition.

[0212] As indicated at Block A in FIG. **29**, the first of the method involves measuring and staking out area using GPS coordinates to ensure proper application rates.

[0213] As indicated at Block B in FIG. **29**, the processed wood fibers, cellulose fiber, wetting agents, tackling agents **96**, and clean fire inhibiting chemicals (CFIC) **97** are blended with a supply of water **98** to make up a fire and smoke inhibiting slurry composition **102**.

[0214] In the illustrative embodiment, the processed wood fibers, cellulose fiber, wetting agents, tackling agents **96** can be provided in a number of different ways and formulations. For example, one can use Hydro-Blanket® Bonded Fiber Matrix(BFM) from Profile Products, which combines Profile Product's Thermally Refined® wood fiber and multi-dimensional pacifiers for greater water-holding capacity. This BFM anchors intimately to the soil through proprietary cross-linked, hydro-colloidal pacifiers and activators and is completely biodegradable and non-toxic. When Hydro-Blanket® Bonded Fiber Matrix is blended and mixed with CFIC **97**, and water **98**, the slurry compositing **102** sprays on as mulch, but dries to form a breathable blanket that bonds more completely with the soil. Thermally Refined® wood fiber starts with 100% recycled wood chips which are thermally processes to create fine, long and highly absorbent fibers, engineered fibers are the source for Profile's superior: yield and coverage; water-holding capacity; growth establishment; wet-bond strength; and erosion control performance. Profile Products offers other brands of wood, cellulose, wood-cellulose blended hydraulically-applied mulches which are preblended with one or more performance enhancing additions.

[0215] Because paper does not hold as much moisture, and does not prevent erosion nearly as well as thermally refined wood fiber mulch, many states and provinces have prohibited the use of paper mulch. Large-scale independent testing has shown that paper mulch is only 25% effective at preventing erosion, whereas wood fiber mulch with no performance enhancing additives is 45% effective at preventing erosion. ASTM standard testing methods also indicate that wood fiber mulches are superior to paper at promoting vegetation establishment. In addition, where steeper or longer slopes exist, and where greater erosion protection is required (greater than 50% effective), there are advanced technologies, beyond basic paper and wood fiber mulches, that are indicated to ensure erosion prevention and vegetation establishment.

[0216] Examples of preblended mulch materials from Profile Products which may be used to practice the manufacture of the fire and smoke inhibiting slurry mixtures of the present invention **102**, include the following wood-based and paper-based mulches described below. The Base Hydraulic Mulch Loading Chart shown in FIG. **30** can be used to estimate how much Profile® brand mulch fiber products (e.g. packaged in 50 lb. bales) will be required to make a fire and smoke inhibiting slurry **102** of the present invention for use on particular incline ground surfaces, of particular slope lengths, over particular surface areas (e.g. in acres). The Hydraulic Loading Chart shown in FIG. **30** for Profile® mulch fiber products provides the required hydraulic loading for specified application rates required by specific Profile® brand mulch fiber materials used on particular slopes, and provided for three specific application rates, namely 1500 lb./acre, 2000 lb./acre, and 2500 lb./acre.

Wood Fiber Mulch

[0217] Materials: 100% wood fiber, made from thermally processed (within a pressurized vessel) wood fiber heated to a temperature greater than 380 degrees Fahrenheit (193 degrees Celsius) for 15 minutes at a pressure greater than 80 psi (552 kPa) and dark green marker dye.

Moisture Content: 12%+/-3%

[0218] Water-Holding Capacity: 1,100% minimum

Approved Large-Scale Erosion Control Effectiveness: 45% minimum.

When comparing the four base paper and wood mulches listed below, the key items to note are the differences in the maximum slope inclinations, slope lengths and the erosion prevention capabilities.

Cellulose (Paper) Fiber Mulch

[0219] Maximum slope inclination: 4:1
 Appl. rate on maximum slope: 1,500-2,000 pounds/acre
 Maximum slope length*: 18 feet
 Functional longevity: up to 3 months
 Erosion control effectiveness: 25%
 Cellulose (Paper) Fiber Mulch with Tackifier
 Maximum slope inclination: 4:1
 Appl. rate on maximum slope: 1,500-2,000 pounds/acre
 Maximum slope length*: 20 feet
 Functional longevity: up to 3 months
 Erosion control effectiveness: 30%

Wood Fiber Mulch

[0220] Maximum slope inclination: 2:1
 Appl. rate on maximum slope: 3,000 pounds/acre
 Maximum slope length*: 28 feet
 Functional longevity: up to 3 months
 Erosion control effectiveness: 45%
 Wood Fiber Mulch with Tackifier
 Maximum slope inclination: 2:1
 Appl. rate on maximum slope: 3,000 pounds/acre
 Maximum slope length*: 30 feet
 Functional longevity: up to 3 months
 Erosion control effectiveness: 50%
 *Maximum slope length is based on a 4H:1V slope. For applications on steeper slopes, the maximum slope length may need to be reduced based on actual site conditions. If greater than 50% erosion prevention effectiveness is desired, then the technologies should be specified and not the four base mulch products listed above.

Stabilized Mulch Matrix (SMM)

[0221] Maximum slope inclination: 2:1
 Appl. rate on maximum slope: 3,500 pounds/acre
 Maximum slope length**: 50 feet
 Minimum cure time: 24 hours
 Functional longevity: 3 to 6 months
 Erosion control effectiveness: 90%

Bonded Fiber Matrix (BFM)

[0222] Maximum slope inclination: 1:1
 Appl. rate on maximum slope: 4,000 pounds/acre
 Maximum slope length**: 75 feet
 Minimum cure time: 24 hours
 Functional longevity: 6 to 12 months
 Erosion control effectiveness: 95%

Engineered Fiber Matrix™ (EFM)

[0223] Maximum slope inclination: >2:1
 Appl. rate on maximum slope: 3,500 pounds/acre
 Maximum slope length**: 50 feet
 Minimum cure time: 24-48 hours
 Functional longevity: Up to 12 months
 Erosion control effectiveness: >95%

High Performance-Flexible Growth Medium™ (HP-FGM™)

[0224] Maximum slope inclination: >1:1
 Appl. rate on maximum slope: 4,500 pounds/acre
 Maximum slope length**: 100 feet
 Minimum cure time: 2 hours*
 Functional longevity: 12 to 18 months
 Erosion control effectiveness: 99.9%

Extended-Term Flexible Growth Medium (ET-FGM)

[0225] Maximum slope inclination: >1:1
 Appl. rate on maximum slope: 4,500 pounds/acre
 Maximum slope length**: 125 feet
 Minimum cure time: 2 hours*
 Functional longevity: 18 to 24 months
 Erosion control effectiveness: 99.95%

[0226] Profile Product's HP-FGM and ET-FGM mulches have very short cure times, and therefore, fire and smoke inhibiting slurry mixtures, employing these mulches, can be applied onto wet soils and during a light rainfall. Maximum slope length is based on a 3H:1V slope. For applications on steeper slopes, the maximum slope length may need to be reduced based on actual site conditions.

[0227] In applications where the fire and smoke inhibiting slurry **102** is applied onto smoldering ashes and ambers of houses destroyed by wildfires, there slope will be generally zero. However, alongside roads and embankments, where wildfires may travel, following specified application rates for specified ground slopes should be followed for optimal performance and results.

[0228] In the illustrative embodiments, the CFIC liquid component **97**, added to the fire and smoke inhibiting slurry mixture **102**, will be realized using Hartindo AF31 clean anti-fire inhibiting chemical liquid, described and specified above.

[0229] When blending the Hartindo AF21 liquid **97** with Profile's hydraulic mulch fiber products in the mixing tank **93**, the following mixture ratio should be used for Hartindo AF21 CFIC **97**: about 1 gallon of Hartindo AF21 per 10 gallons of water added to the mixing tank **93** during the blending and mixing of the fire and smoke inhibiting slurry **102**. So, as shown in FIG. **30**, when mixing 2800 gallons of water to 1450 lbs. of mulch fiber (29x50 lb Profile® mulch fiber bales) to make a batch of fire and smoke inhibiting slurry **102**, at least 280 gallons of Hartindo AF31 liquid **97** will be added to the mixing tank **93** and mixed well with the 2800 gallons water and 1450 lbs. of mulch fiber, preferably from Profile Products, LLC of Buffalo Grove, Ill., when using the 1500 lb./acre application rate.

[0230] However, additional amounts of Hartindo AF21 **97** can be added to the 2800 gallons of water so as to increase the amount of AF21 CFIC liquid that infuses into the surface of the mulch fibers when being mixed within the mixing tank **93** during the blending and mixing steps of the process. Notably, a large percentage of the water in the mixing tank **93** will function as a hydraulic carrier fluid when spraying AF21-infused mulch fibers in the slurry mixture to the ground surface being coated during spray applications, and thereafter, this water will quickly dry off when curing under the hot Sun, leaving behind ingused AF21 chemicals within the mulch fibers.

[0231] As indicated at Block C in FIG. 29, the blended fire and smoke inhibiting slurry mixture is mixed in the mixing tank 93 on the mobile vehicle 90 supporting hydraulic spray equipment 101.

[0232] As indicated at Block D in FIG. 29, the mixed fire and smoke inhibiting slurry mixture 102 is then hydraulically sprayed on the specific ground surface using hydraulic spray equipment 101 supported on the mobile spray vehicle 90. The slurry spray process can be guided by GPS coordinates of the staked out ground surface regions, using GPS receiver and controls 100.

[0233] As indicated at Block E in FIG. 29, a secondary CFIC liquid (e.g. Hartindo AF31 anti-fire inhibiting chemical liquid) 113 is sprayed over the fire and smoke inhibiting slurry coating 102 after it has been hydraulically sprayed onto the ground. Once the slurry coating 102 has dried, and adheres to the ground surface, it will provide erosion control, as well as fire protection and smoke reduction in the presence of a wildfire in accordance with the scope and spirit of the present invention.

[0234] FIG. 31 shows a neighborhood of houses surrounded by a high-risk wildfire region. As shown, a wild-fire break region 105A is sprayed on the ground surface region all around a neighborhood of houses, using the clean fire and smoke inhibiting slurry composition of the present invention 102 hydraulically sprayed onto the ground surface.

[0235] FIG. 32 shows a highway surrounded by high-risk wildfire regions on both sides of the highway. As shown, the wild-fire break regions 105A on both sides of the highway are sprayed using the clean fire and smoke inhibiting slurry composition 102 hydraulically sprayed from the vehicle 90 onto the ground surface. Spray operators can stand on top of the platform above the mixing tank 93 and use the mounted spray gun to coat the ground surface with the wet slurry mixture 102. AF31 liquid 113 can then be sprayed upon the surface of the slurry coating 102 on the ground. By applying the clean fire and smoke inhibiting slurry composition 102 over a smoldering fire, followed with an AF31 spray coating, this double coating functions like a blanket for chemically breaking the combustion phase of a traveling wildfire and reducing smoke, and the need for water reduced to prevent reignition to neighboring areas.

[0236] FIG. 33 shows a house that just burned to the ground after a wildfire passed through an unprotected neighborhood. As shown, the clean fire and smoke inhibiting slurry composition 102 is sprayed over the glowing ambers and fire ash to suppress and prevent re-ignition of the fire, and reduce the production of smoke and creation of toxic water runoff during post fire management operations. Spray operators can stand on top of the platform above the mixing tank 93 and use the mounted spray gun to coat the ground surface with the wet slurry mixture 102. AF31 liquid 113 can then be sprayed upon the surface of the slurry coating 102 on hot glowing ambers and ashes. By applying the clean fire and smoke inhibiting slurry composition 102 over a smoldering fire, followed with an AF31 spray coating, this double coating functions like a blanket for chemically breaking the combustion phase of a traveling wildfire and reducing smoke and the need for water to prevent reignition to neighboring areas.

[0237] FIG. 34 shows a house or building that is burning due to a fire within the building. As shown, the wet fire and smoke inhibiting slurry composition of the present invention 102 is hydraulically sprayed on and over the fire in effort to

suppress the fire and reduce the production of smoke. In some applications, this method may be effective in fire and smoke suppression using a minimal amount of water.

Modifications to the Present Invention which Readily Come to Mind

[0238] The illustrative embodiments disclose the use of clean anti-fire chemicals from Hartindo Chemicatama Industri, particular Hartindo AAF31, for clinging to the surfaces of wood, lumber, and timber, and other combustible matter, wherever wild fires may travel. However, it is understood that alternative clean anti-fire chemical liquids may be used to practice the various wild fire suppression methods according to the principles of the present invention. [0239] These and other variations and modifications will come to mind in view of the present invention disclosure. [0240] While several modifications to the illustrative embodiments have been described above, it is understood that various other modifications to the illustrative embodiment of the present invention will readily occur to persons with ordinary skill in the art. All such modifications and variations are deemed to be within the scope and spirit of the present invention as defined by the accompanying Claims to Invention.

1. A fire and smoke inhibiting slurry mixing and spray application system comprising:

- a mixing tank with an integrated agitator mechanism for mixing wood and/or cellulose fibers, wetting agents, tacking agents, and clean fire inhibiting chemical (CFIC) to produce an environmentally-clean aqueous-based clean fire and smoke inhibiting slurry; and
- a hydraulic pumping apparatus and spray nozzle for mixing and spraying said environmentally-clean aqueous-based clean fire and smoke inhibiting slurry on or more of the following:

- (i) ground surfaces to create CFIC-based fire breaks around regions to be protected,
- (ii) smoldering ambers and ash after the present of wild-fires to reduce toxic waster water runoff and smoke, and
- (iii) burning fires destroying combustion material.

2. The fire and smoke inhibiting slurry spray application system of claim 1 which further comprises:

- a second liquid tank for storing a secondary CFIC liquid, and supplying an spray system for spraying the secondary CFIC liquid using a spray nozzle to apply said CFIC liquid to the surface of the slurry coating after it has been applied to said ground surface.

3. A method of making and applying a fire and smoke inhibiting slurry composition on ground surfaces before the incidence of wild-fires, and/or also thereafter, upon smoldering ambers and ashes to reduce smoke and suppress fire re-ignition, said method comprising the steps of:

- (a) blending wood and/or cellulose fibers, and clean fire inhibiting chemicals (CFIC) with a supply of water to make up a fire and smoke inhibiting slurry composition;
- (b) mixing the blended fire and smoke inhibiting slurry composition in a mixing tank on a mobile vehicle supporting hydraulic spray equipment; and
- (c) hydraulically spraying the mixed fire and smoke inhibiting slurry mixture on a ground surface using said hydraulic spray equipment supported on the mobile spray vehicle,

wherein, once said fire and smoke inhibiting slurry coating has dried, and adheres to said ground surface, said

slurry coating providing erosion control, and fire protection and smoke reduction in the presence of a wildfire.

4. The method of claim 3, which further comprises:

(d) spraying a CFIC liquid over said fire and smoke inhibiting slurry coating after it has been hydraulically sprayed onto said ground, to provide further fire and smoke reduction in the presence of a wildfire.

5. The method of claim 3, wherein said wood and/or cellulose fibers are obtained from materials selected from the group consisting of wood fiber mulch, cellulose fiber mulch, cellulose fiber mulch with tackifier, wood fiber mulch wood fiber mulch with tackifier, stabilized mulch matrix, bonded fiber matrix, engineered fiber matrix, high performance-flexible growth medium, and extended-term flexible growth medium.

6. The method of claim 3, wherein during step (a) further blending one or more of a wetting agent, and a tacking agent.

7. The method of claim 3, wherein during step (c), said ground surface is selected from the group consisting of (i) a

ground surface region around a neighborhood of houses located in a high-risk wildfire region; (ii) a highway surrounded by a high-risk wildfire region on both sides; (iii) a piece of land on which a house just burned to the ground after a wildfire passed through; and (iv) on a building with a fire burning within the building.

8. A method of preventing re-ignition of a fire on grounds burned by the fire, and the generation of considerable waste water, toxic run off and toxic smoke, said method comprising:

(i) making and applying a fire and smoke inhibiting slurry composition containing clean fire inhibiting chemicals (CFIC), and cellulose and/or wood fiber, mixed with water and other additives; and

(b) applying said fire and smoke inhibiting slurry composition over smoldering ambers and ashes on said grounds burned by said fire so as to prevent re-ignition of said fire, and generation of considerable waste water, toxic run off and toxic smoke.

* * * * *