



- (51) **International Patent Classification:**
H04N 19/597 (2014.01) H04N 19/80 (2014.01)
- (21) **International Application Number:**
PCT/US2020/052900
- (22) **International Filing Date:**
25 September 2020 (25.09.2020)
- (25) **Filing Language:** English
- (26) **Publication Language:** English
- (30) **Priority Data:**
62/907,398 27 September 2019 (27.09.2019) US
62/907,583 28 September 2019 (28.09.2019) US
17/031,792 24 September 2020 (24.09.2020) US
- (71) **Applicant: APPLE INC.** [US/US]; One Apple Park Way, Cupertino, California 95014 (US).

- (72) **Inventors: TOURAPIS, Alexandros;** One Apple Park Way, Cupertino, California 95014 (US). **KIM, Jungsun;** One Apple Park Way, Cupertino, California 95014 (US). **MAMMOU, Khaled;** One Apple Park Way, Cupertino, California 95014 (US). **MEHLEM, Dominik;** One Apple Park Way, Cupertino, California 95014 (US).
- (74) **Agent: KOWERT, Robert C.;** Kowert, Hood, Munyon, Rankin & Goetzel, P.C., 1120 S. Capital of Texas Highway, Building 2, Suite 300, Austin, Texas 78746 (US).
- (81) **Designated States** (unless otherwise indicated, for every kind of national protection available): AE, AG, AL, AM, AO, AT, AU, AZ, BA, BB, BG, BH, BN, BR, BW, BY, BZ, CA, CH, CL, CN, CO, CR, CU, CZ, DE, DJ, DK, DM, DO, DZ, EC, EE, EG, ES, FI, GB, GD, GE, GH, GM, GT, HN, HR, HU, ID, IL, IN, IR, IS, IT, JO, JP, KE, KG, KH, KN, KP, KR, KW, KZ, LA, LC, LK, LR, LS, LU, LY, MA, MD, ME, MG, MK, MN, MW, MX, MY, MZ, NA, NG, NI, NO, NZ, OM, PA, PE, PG, PH, PL, PT, QA, RO, RS, RU, RW,

(54) **Title:** VIDEO-BASED POINT CLOUD COMPRESSION WITH NON-NORMATIVE SMOOTHING

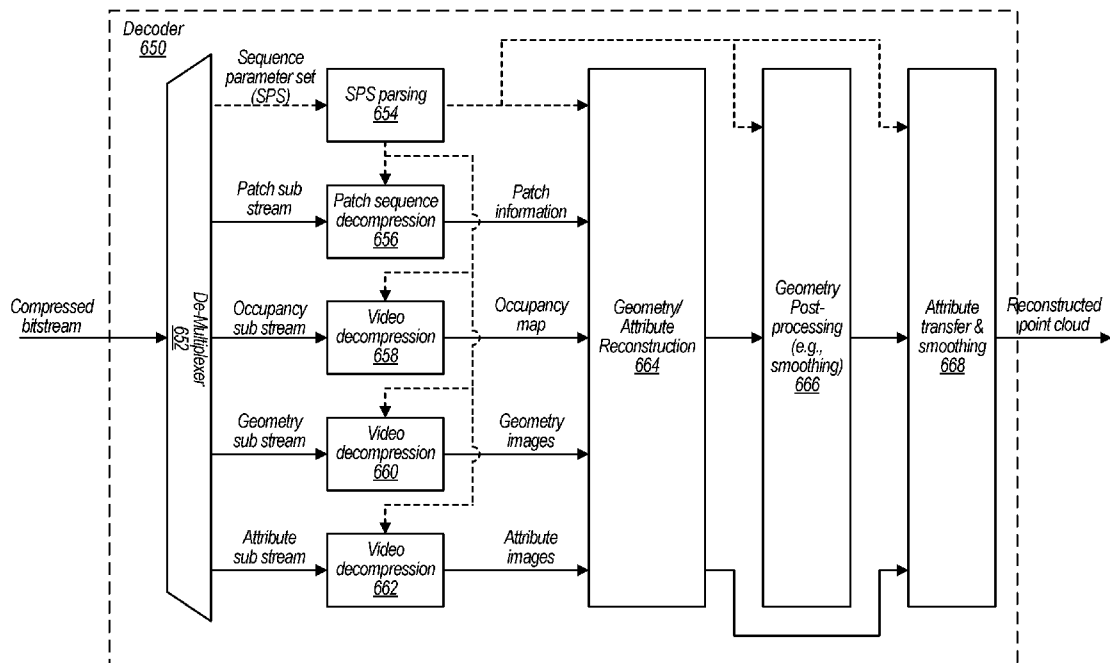

FIG. 6K

(57) **Abstract:** A system comprises an encoder configured to compress attribute and/or spatial information for a point cloud and/or a decoder configured to decompress compressed attribute and/or spatial information for the point cloud. To compress the attribute and/or spatial information, the encoder is configured to convert a point cloud into an image based representation. Also, the decoder is configured to generate a decompressed point cloud based on an image based representation of a point cloud. In some embodiments, an encoder applies an attribute transfer function to attributes of an image based representation with out-of-loop smoothing such that a decoder may apply any smoothing filter supported by the decoder without being restricted to using a similar smoothing filter as the encoder.



SA, SC, SD, SE, SG, SK, SL, ST, SV, SY, TH, TJ, TM, TN,
TR, TT, TZ, UA, UG, US, UZ, VC, VN, WS, ZA, ZM, ZW.

(84) Designated States (*unless otherwise indicated, for every kind of regional protection available*): ARIPO (BW, GH, GM, KE, LR, LS, MW, MZ, NA, RW, SD, SL, ST, SZ, TZ, UG, ZM, ZW), Eurasian (AM, AZ, BY, KG, KZ, RU, TJ, TM), European (AL, AT, BE, BG, CH, CY, CZ, DE, DK, EE, ES, FI, FR, GB, GR, HR, HU, IE, IS, IT, LT, LU, LV, MC, MK, MT, NL, NO, PL, PT, RO, RS, SE, SI, SK, SM, TR), OAPI (BF, BJ, CF, CG, CI, CM, GA, GN, GQ, GW, KM, ML, MR, NE, SN, TD, TG).

Published:

— *with international search report (Art. 21(3))*

VIDEO-BASED POINT CLOUD COMPRESSION WITH NON-NORMATIVE SMOOTHING

BACKGROUND

Technical Field

[0001] This disclosure relates generally to compression and decompression of point clouds comprising a plurality of points, each having associated spatial information and attribute information.

Description of the Related Art

[0002] Various types of sensors, such as light detection and ranging (LIDAR) systems, 3-D-cameras, 3-D scanners, etc. may capture data indicating positions of points in three dimensional space, for example positions in the X, Y, and Z planes. Also, such systems may further capture attribute information in addition to spatial information for the respective points, such as color information (e.g. RGB values), texture information, intensity attributes, reflectivity attributes, motion related attributes, modality attributes, or various other attributes. In some circumstances, additional attributes may be assigned to the respective points, such as a time-stamp when the point was captured. Points captured by such sensors may make up a “point cloud” comprising a set of points each having associated spatial information and one or more associated attributes. In some circumstances, a point cloud may include thousands of points, hundreds of thousands of points, millions of points, or even more points. Also, in some circumstances, point clouds may be generated, for example in software, as opposed to being captured by one or more sensors. In either case, such point clouds may include large amounts of data and may be costly and time-consuming to store and transmit.

SUMMARY OF EMBODIMENTS

[0003] In some embodiments, a system includes one or more sensors configured to capture points that collectively make up a point cloud, wherein each of the points comprises spatial information identifying a spatial location of the respective point and attribute information defining one or more attributes associated with the respective point.

[0004] The system also includes an encoder configured to compress the attribute and/or spatial information of the points. To compress the attribute and/or spatial information, the encoder is configured to determine, for the point cloud, a plurality of patches, each corresponding to portions of the point cloud. The encoder is further configured to, for each patch, generate a patch image comprising the set of points corresponding to the patch projected onto a patch plane and generate another patch image comprising geometry information, such as depth information, for the set of points corresponding to the patch, wherein the geometry information comprises depths of the points in a direction perpendicular to the patch plane.

[0005] For example, the geometry patch image corresponding to the patch projected onto a patch plane may depict the points of the point cloud included in the patch in two directions, such as an X and Y direction. The points of the point cloud may be projected onto a patch plane approximately perpendicular to a normal vector, normal to a surface of the point cloud at the location of the patch. Also, for example, the geometry patch image comprising depth information for the set of points included in the patch may depict depth information, such as depth distances in a Z direction. To depict the depth information, the geometry patch image may include a parameter that varies in intensity based on the depth of points in the point cloud at a particular location in the patch image. For example, the geometry patch image depicting depth information may have a same shape as the attribute patch image representing attributes of points projected onto the patch plane. However, the geometry information patch image may be an image comprising image attributes, such as one or more colors, that vary in intensity based on depth, wherein the intensity of the one or more image attributes corresponds to a depth of a corresponding point of the point cloud at a location in the geometry patch image, where the image attribute is displayed in the geometry patch image depicting depth. For example, points that are closer to the patch plane may be encoded as darker values in the patch image depicting depth and points that are further away from the patch plane may be encoded as lighter

values in the patch image depicting depth, for example in a monochromatic patch image depicting depth. Thus, the depth information patch image when aligned with other patch images representing attribute values for points projected onto the patch plane may indicate the relative depths of the points projected onto the patch plane, based on respective image attribute intensities at locations in the geometry patch image that correspond to locations of the points in the other patch images comprising point cloud points projected onto the patch plane.

[0006] The encoder is further configured to pack generated patch images (including a geometry patch image and one or more additional patch images for one or more other attributes such as colors, textures, reflectances, etc.) for each of the determined patches into one or more image frames. Also, the encoder is configured to provide the one or more packed image frames to a video encoding component (which may be included in the encoder or may be a separate video encoding component). Additionally, the encoder is configured to down-scale the packed image frames in 2D space. For example, the encoder may utilize one or more down-scaling features of a video encoding component to down-scale the image frames in a 2D domain. For example, the encoder may utilize a video encoding component in accordance with the High Efficiency Video Coding (HEVC/H.265) standard or other suitable standards such as, the Advanced Video Coding (AVC/H.264) standard, the AOMedia Video 1 (AV1) video coding format produced by the Alliance for Open Media (AOMedia), etc. In some embodiments, the encoder may utilize an image encoder in accordance with a Motion Picture Experts Group (MPEG), a Joint Photography Experts Group (JPEG) standard, an International Telecommunication Union-Telecommunication standard (e.g. ITU-T standard), etc.

[0007] Additionally, the encoder is configured to apply an attribute transform function on the packed patch images comprising attribute patches to compensate for distortion or artifacts that may be included in a decompressed/reconstructed version of the point cloud. For example, the encoder may video encode and video decode image frames comprising geometry patch images. The encoder may further determine distortion or artifacts in the decoded/decompressed geometry patch images. The encoder may then select or adjust an attribute transfer function to be applied to attribute patch images to compensate for the compression/decompression artifacts and/or distortion introduced into the point cloud geometry. However, the encoder may refrain from using points that have undergone a geometry smoothing process, for example via a smoothing filter, when determining the attribute transfer function. By not using smoothed

geometry points to determine the attribute transfer function, the encoder removes encoder smoothing as a normative feature of the encoder that must be matched by a matching smoothing filter at the decoder.

[0008] For example, if attribute transfer is applied to encoder smoothed points that have been smoothed by an encoder side geometry smoothing filter, then a decoder would need to apply the same geometry smoothing filter on decompressed geometry points in order for a signaled attribute transfer function to properly adjust the attributes of the points to match the smoothed geometry. However, if an attribute transfer function is applied at the encoder to non-smoothed points, a decoder can apply a signaled attribute transfer function on reconstructed points and optionally select a non-normative smoothing filter to be applied at the decoder. Additionally, the decoder may apply a second attribute transfer function to compensate for changes in position of points of the point cloud due to application of a decoder side non-normative geometry smoothing filter. Because the decoder side geometry smoothing filter is non-normative, a designer or user of the decoding process may customize the geometry smoothing filter to meet the designer's or user's needs without being restricted to using a normative geometry smoothing filter specified in a standard.

[0009] In some embodiments, a decoder is configured to receive one or more encoded image frames comprising patch images for a plurality of patches of a compressed point cloud, wherein, for each patch, the one or more encoded image frames comprise: a patch image comprising a set of points of the patch projected onto a patch plane and a patch image comprising depth information for the set of points of the patch, wherein the depth information indicates depths of the points of the patch in a direction perpendicular to the patch plane. In some embodiments, a depth patch image may be packed into an image frame with other attribute patch images. For example, a decoder may receive one or more image frames comprising packed patch images as generated by the encoder described above. The image frames, or a portion thereof, may have been down-scaled at an encoder, and the decoder may up-scale the down-scaled image frames, in a 2D video domain.

[0010] The decoder is further configured to video decode the one or more video encoded image frames comprising the patch images. In some embodiments, the decoder may utilize a video decoder in accordance with the High Efficiency Video Coding (HEVC) standard or other

suitable standards such as, the Advanced Video Coding (AVC) standard, the AOMedia Video 1 (AV1) video coding format, etc. In some embodiments, the decoder may utilize an image decoder in accordance with a Motion Picture Experts Group (MPEG) or a Joint Photography Experts Group (JPEG) standard, etc.

[0011] The decoder is further configured to receive or determine relationship information indicating relationships between the respective attribute patch images, depth patch images, and/or image frames. For example, the decoder may receive relationship information in a compressed point cloud file, wherein the relationship information was determined by an encoder. Also, in some embodiments, the decoder may determine relationship information based on information included in a compressed point cloud file, such as an occupancy map and/or auxiliary information for the compressed point cloud. In some embodiments, the decoder may utilize the received or determined relationship information to adjust one or more parameters used to video decode the video encoded image frames.

[0012] The decoder is further configured to determine, for each patch, spatial information for the set of points of the patch based, at least in part, on the attribute patch image comprising the set of points of the patch projected onto the patch plane and the geometry patch image comprising the depth information for the set of points of the patch, and generate a reconstructed version of the compressed point cloud based, at least in part, on the determined spatial information for the plurality of patches and the attribute information included in the patches.

[0013] Additionally, the decoder may be configured to apply a non-normative geometry smoothing filter at the encoder and use both un-smoothed and smoothed geometries of the point cloud to determine a decoder specific attribute transfer function to be applied to the attributes of the point cloud to compensate for the decoder side geometry smoothing. In some embodiments, various smoothing filters may be used. In some embodiments, a decoder may support normative and non-normative smoothing filters, but a user or designer of the decoder may not be restricted to using only normative smoothing filters.

BRIEF DESCRIPTION OF THE DRAWINGS

[0015] FIG. 1 illustrates a system comprising a sensor that captures information for points of a point cloud and an encoder that compresses spatial information and attribute information of the point cloud, where the compressed spatial and attribute information is sent to a decoder, according to some embodiments.

[0016] FIG. 2A illustrates components of an encoder for encoding intra point cloud frames, according to some embodiments.

[0017] FIG. 2B illustrates components of a decoder for decoding intra point cloud frames, according to some embodiments.

[0018] FIG. 2C illustrates components of an encoder for encoding inter point cloud frames, according to some embodiments.

[0019] FIG. 2D illustrates components of a decoder for decoding inter point cloud frames, according to some embodiments.

[0020] FIG. 3A illustrates an example patch segmentation process, according to some embodiments.

[0021] FIG. 3B illustrates an example image frame comprising packed patch images and padded portions, according to some embodiments.

[0022] FIG. 3C illustrates an example image frame comprising patch portions and padded portions, according to some embodiments.

[0023] FIG. 3D illustrates a point cloud being projected onto multiple projections, according to some embodiments.

[0024] FIG. 3E illustrates a point cloud being projected onto multiple parallel projections, according to some embodiments.

[0025] FIG. 4A illustrates components of an encoder for encoding intra point cloud frames with color conversion, according to some embodiments.

[0026] FIG. 4B illustrates components of an encoder for encoding inter point cloud frames with color conversion, according to some embodiments.

[0027] FIG. 4C illustrates components of a closed-loop color conversion module, according to some embodiments.

[0028] FIG. 4D illustrates an example process for determining a quality metric for a point cloud upon which an operation has been performed, according to some embodiments.

[0029] FIG. 5A illustrates components of an encoder that includes geometry, texture, and/or other attribute downscaling, according to some embodiments.

[0030] FIG. 5B illustrates components of a decoder that includes geometry, texture, and/or other attribute upscaling, according to some embodiments.

[0031] FIG. 5C illustrates rescaling from the perspective of an encoder, according to some embodiments.

[0032] FIG. 5D illustrates rescaling from the perspective of a decoder, according to some embodiments.

[0033] FIG. 5E illustrates an example open loop rescaling, according to some embodiments.

[0034] FIG. 5F illustrates an example closed loop rescaling, according to some embodiments.

[0035] FIG. 5G illustrates an example closed loop rescaling with multiple attribute layers, according to some embodiments.

[0036] FIG. 5H illustrates an example of video level spatiotemporal scaling, according to some embodiments.

[0037] FIG. 5I illustrates an example closed loop rescaling with spatiotemporal scaling, according to some embodiments.

[0038] FIG. 5J illustrates a process of encoding/compressing image frames of a point cloud using down-scaling, according to some embodiments.

[0039] FIG. 5K illustrates a process of determining to down-scaling image frames using open-loop or closed-loop down-scaling, according to some embodiments.

[0040] FIG. 5L illustrates a process of decoding/decompressing image frames of a point cloud using up-scaling, according to some embodiments.

[0041] FIG. 6A illustrates components of an encoder that further includes pre-video compression texture processing and/or filtering and pre video compression geometry processing/filtering, according to some embodiments.

[0042] FIG. 6B illustrates components of a decoder that further includes post video decompression texture processing and/or filtering and post video decompression geometry processing/filtering, according to some embodiments.

[0043] FIG. 6C illustrates, a bit stream structure for a compressed point cloud, according to some embodiments.

[0044] FIG. 6D illustrates a process for generating video encoded image frames for patches of a point cloud taking into account relationship information between the patches packed into the image frames, according to some embodiments.

[0045] FIG. 6E illustrates a process for generating video encoded image frames taking into account pooled distortion for a set of patches corresponding to a same set of points, according to some embodiments.

[0046] FIG. 6F illustrates a process for generating video encoded image frames taking into account patch edges, according to some embodiments.

[0047] FIG. 6G illustrates a process for reconstructing a point cloud based on video encoded image frames comprising patches of the point cloud, wherein relationship information between the patches packed into the image frames is taken into account, according to some embodiments.

[0048] FIG. 6H illustrates a process of upscaling a patch image included in an image frame taking into account edges of the patch image determined based on received or determined relationship information for the patches, according to some embodiments.

[0049] FIG. 6I illustrates an example application where an attribute plane is up-scaled using its corresponding geometry information and the geometry extracted edges, according to some embodiments.

[0050] FIG. 6J illustrates an example encoder that supports geometry smoothing outside of an attribute transfer loop of the encoder, according to some embodiments.

[0051] FIG. 6K illustrates an example decoder that includes an attribute transfer function and smoothing process that allows for use of non-normative smoothing filters at the decoder, according to some embodiments.

[0052] FIG. 7A illustrates an example of a point cloud compression network abstraction layer (PCCNAL) unit based bit stream, according to some embodiments.

[0053] FIG. 7B illustrates an example of a PCCNAL units grouped by picture order count (POC), according to some embodiments.

[0054] FIG. 7C illustrates an example of a PCCNAL unit grouped by type, according to some embodiments.

[0055] FIG. 8A illustrates a process for compressing attribute and spatial information of a point cloud, according to some embodiments.

[0056] FIG. 8B illustrates a process for decompressing attribute and spatial information of a point cloud, according to some embodiments.

[0057] FIG. 8C illustrates patch images being generated and packed into an image frame to compress attribute and spatial information of a point cloud, according to some embodiments.

[0058] FIG. 9 illustrates patch images being generated and packed into an image frame to compress attribute and spatial information of a moving or changing point cloud, according to some embodiments.

[0059] FIG. 10 illustrates a decoder receiving image frames comprising patch images, patch information, and an occupancy map, and generating a decompressed representation of a point cloud, according to some embodiments.

[0060] FIG. 11A illustrates an encoder, adjusting encoding based on one or more masks for a point cloud, according to some embodiments.

[0061] FIG. 11B illustrates a decoder, adjusting decoding based on one or more masks for a point cloud, according to some embodiments.

[0062] FIG. 12A illustrates more detail regarding compression of an occupancy map, according to some embodiments.

[0063] FIG. 12B illustrates example blocks and traversal patterns for compressing an occupancy map, according to some embodiments.

[0064] FIG. 12C illustrates more detail regarding compression of an occupancy map, according to some embodiments.

[0065] FIG. 13 illustrates compressed point cloud information being used in a 3-D application, according to some embodiments.

[0066] FIG. 14 illustrates compressed point cloud information being used in a virtual reality application, according to some embodiments.

[0067] FIG. 15 illustrates an example computer system that may implement an encoder or decoder, according to some embodiments.

[0068] This specification includes references to “one embodiment” or “an embodiment.” The appearances of the phrases “in one embodiment” or “in an embodiment” do not necessarily refer to the same embodiment. Particular features, structures, or characteristics may be combined in any suitable manner consistent with this disclosure.

[0069] “Comprising.” This term is open-ended. As used in the appended claims, this term does not foreclose additional structure or steps. Consider a claim that recites: “An apparatus comprising one or more processor units” Such a claim does not foreclose the apparatus from including additional components (e.g., a network interface unit, graphics circuitry, etc.).

[0070] “Configured To.” Various units, circuits, or other components may be described or claimed as “configured to” perform a task or tasks. In such contexts, “configured to” is used to connote structure by indicating that the units/circuits/components include structure (e.g., circuitry) that performs those task or tasks during operation. As such, the unit/circuit/component can be said to be configured to perform the task even when the specified unit/circuit/component is not currently operational (e.g., is not on). The units/circuits/components used with the “configured to” language include hardware—for example, circuits, memory storing program instructions executable to implement the operation, etc. Reciting that a unit/circuit/component is “configured to” perform one or more tasks is expressly intended not to invoke 35 U.S.C. § 112(f), for that unit/circuit/component. Additionally, “configured to” can include generic structure (e.g., generic circuitry) that is

manipulated by software and/or firmware (e.g., an FPGA or a general-purpose processor executing software) to operate in manner that is capable of performing the task(s) at issue. “Configure to” may also include adapting a manufacturing process (e.g., a semiconductor fabrication facility) to fabricate devices (e.g., integrated circuits) that are adapted to implement or perform one or more tasks.

[0071] “First,” “Second,” etc. As used herein, these terms are used as labels for nouns that they precede, and do not imply any type of ordering (e.g., spatial, temporal, logical, etc.). For example, a buffer circuit may be described herein as performing write operations for “first” and “second” values. The terms “first” and “second” do not necessarily imply that the first value must be written before the second value.

[0072] “Based On.” As used herein, this term is used to describe one or more factors that affect a determination. This term does not foreclose additional factors that may affect a determination. That is, a determination may be solely based on those factors or based, at least in part, on those factors. Consider the phrase “determine A based on B.” While in this case, B is a factor that affects the determination of A, such a phrase does not foreclose the determination of A from also being based on C. In other instances, A may be determined based solely on B.

DETAILED DESCRIPTION

[0073] As data acquisition and display technologies have become more advanced, the ability to capture point clouds comprising thousands or millions of points in 2-D or 3-D space, such as via LIDAR systems, has increased. Also, the development of advanced display technologies, such as virtual reality or augmented reality systems, has increased potential uses for point clouds. However, point cloud files are often very large and may be costly and time-consuming to store and transmit. For example, communication of point clouds over private or public networks, such as the Internet, may require considerable amounts of time and/or network resources, such that some uses of point cloud data, such as real-time uses, may be limited. Also, storage requirements of point cloud files may consume a significant amount of storage capacity of devices storing the point cloud files, which may also limit potential applications for using point cloud data.

[0074] In some embodiments, an encoder may be used to generate a compressed point cloud to reduce costs and time associated with storing and transmitting large point cloud files. In some embodiments, a system may include an encoder that compresses attribute and/or spatial information of a point cloud file such that the point cloud file may be stored and transmitted more quickly than non-compressed point clouds and in a manner that the point cloud file may occupy less storage space than non-compressed point clouds. In some embodiments, compression of attributes of points in a point cloud may enable a point cloud to be communicated over a network in real-time or in near real-time. For example, a system may include a sensor that captures attribute information about points in an environment where the sensor is located, wherein the captured points and corresponding attributes make up a point cloud. The system may also include an encoder that compresses the captured point cloud attribute information. The compressed attribute information of the point cloud may be sent over a network in real-time or near real-time to a decoder that decompresses the compressed attribute information of the point cloud. The decompressed point cloud may be further processed, for example to make a control decision based on the surrounding environment at the location of the sensor. The control decision may then be communicated back to a device at or near the location of the sensor, wherein the device receiving the control decision implements the control decision in real-time or near real-time. In some embodiments, the decoder may be associated with an augmented reality system and the decompressed attribute information may

be displayed or otherwise used by the augmented reality system. In some embodiments, compressed attribute information for a point cloud may be sent with compressed spatial information for points of the point cloud. In other embodiments, spatial information and attribute information may be separately encoded and/or separately transmitted to a decoder.

[0075] In some embodiments, a system may include a decoder that receives one or more sets of point cloud data comprising compressed attribute information via a network from a remote server or other storage device that stores the one or more point cloud files. For example, a 3-D display, a holographic display, or a head-mounted display may be manipulated in real-time or near real-time to show different portions of a virtual world represented by point clouds. In order to update the 3-D display, the holographic display, or the head-mounted display, a system associated with the decoder may request point cloud data from the remote server based on user manipulations of the displays, and the point cloud data may be transmitted from the remote server to the decoder and decoded by the decoder in real-time or near real-time. The displays may then be updated with updated point cloud data responsive to the user manipulations, such as updated point attributes.

[0076] In some embodiments, a system, may include one or more LIDAR systems, 3-D cameras, 3-D scanners, etc., and such sensor devices may capture spatial information, such as X, Y, and Z coordinates for points in a view of the sensor devices. In some embodiments, the spatial information may be relative to a local coordinate system or may be relative to a global coordinate system (for example, a Cartesian coordinate system may have a fixed reference point, such as a fixed point on the earth, or may have a non-fixed local reference point, such as a sensor location).

[0077] In some embodiments, such sensors may also capture attribute information for one or more points, such as color attributes, texture attributes, reflectivity attributes, velocity attributes, acceleration attributes, time attributes, modalities, and/or various other attributes. In some embodiments, other sensors, in addition to LIDAR systems, 3-D cameras, 3-D scanners, etc., may capture attribute information to be included in a point cloud. For example, in some embodiments, a gyroscope or accelerometer may capture motion information to be included in a point cloud as an attribute associated with one or more points of the point cloud. For example, a vehicle equipped with a LIDAR system, a 3-D camera, or a 3-D scanner may include the

vehicle's direction and speed in a point cloud captured by the LIDAR system, the 3-D camera, or the 3-D scanner. For example, when points in a view of the vehicle are captured they may be included in a point cloud, wherein the point cloud includes the captured points and associated motion information corresponding to a state of the vehicle when the points were captured.

Example System Arrangement

[0078] FIG. 1 illustrates a system comprising a sensor that captures information for points of a point cloud and an encoder that compresses attribute information of the point cloud, where the compressed attribute information is sent to a decoder, according to some embodiments.

[0079] System 100 includes sensor 102 and encoder 104. Sensor 102 captures a point cloud 110 comprising points representing structure 106 in view 108 of sensor 102. For example, in some embodiments, structure 106 may be a mountain range, a building, a sign, an environment surrounding a street, or any other type of structure. In some embodiments, a captured point cloud, such as captured point cloud 110, may include spatial and attribute information for the points included in the point cloud. For example, point A of captured point cloud 110 comprises X, Y, Z coordinates and attributes 1, 2, and 3. In some embodiments, attributes of a point may include attributes such as R, G, B color values, a velocity at the point, an acceleration at the point, a reflectance of the structure at the point, a time stamp indicating when the point was captured, a string-value indicating a modality when the point was captured, for example "walking", or other attributes. The captured point cloud 110 may be provided to encoder 104, wherein encoder 104 generates a compressed version of the point cloud (compressed attribute information 112) that is transmitted via network 114 to decoder 116. In some embodiments, a compressed version of the point cloud, such as compressed attribute information 112, may be included in a common compressed point cloud that also includes compressed spatial information for the points of the point cloud or, in some embodiments, compressed spatial information and compressed attribute information may be communicated as separate sets of data.

[0080] In some embodiments, encoder 104 may be integrated with sensor 102. For example, encoder 104 may be implemented in hardware or software included in a sensor

device, such as sensor 102. In other embodiments, encoder 104 may be implemented on a separate computing device that is proximate to sensor 102.

Example 3D Intra- Frame Encoder

[0081] FIG. 2A illustrates components of an encoder for encoding 3D intra point cloud frames, according to some embodiments. In some embodiments, the encoder described above in regard to FIG. 1 may operate in a similar manner as encoder 200 described in Figs. 2A and encoder 250 described in FIG. 2C.

[0082] The encoder 200 receives uncompressed point cloud 202 and generates compressed point cloud information 204. In some embodiments, an encoder, such as encoder 200, may receive the uncompressed point cloud 202 from a sensor, such as sensor 102 illustrated in FIG. 1, or, in some embodiments, may receive the uncompressed point cloud 202 from another source, such as a graphics generation component that generates the uncompressed point cloud in software, as an example.

[0083] In some embodiments, an encoder, such as encoder 200, includes decomposition into patches module 206, packing module 208, spatial image generation module 210, texture image generation module 212, and attribute information generation module 214. In some embodiments, an encoder, such as encoder 200, also includes image frame padding module 216, video compression module 218 and multiplexer 224. In addition, in some embodiments an encoder, such as encoder 200, may include an occupancy map compression module, such as occupancy map compression module 220, and an auxiliary patch information compression module, such as auxiliary patch information compression module 222. In some embodiments, an encoder, such as encoder 200, converts a 3D point cloud into an image-based representation along with some meta data (e.g., occupancy map and patch info) necessary to convert the compressed point cloud back into a decompressed point cloud.

[0084] In some embodiments, the conversion process decomposes the point cloud into a set of patches (e.g., a patch is defined as a contiguous subset of the surface described by the point cloud), which may be overlapping or not, such that each patch may be described by a

depth field with respect to a plane in 2D space. More details about the patch decomposition process are provided above with regard to FIGs. 3A-3C.

[0085] After or in conjunction with the patches being determined for the point cloud being compressed, a 2D sampling process is performed in planes associated with the patches. The 2D sampling process may be applied in order to approximate each patch with a uniformly sampled point cloud, which may be stored as a set of 2D patch images describing the geometry/texture/attributes of the point cloud at the patch location. The “Packing” module 208 may store the 2D patch images associated with the patches in a single (or multiple) 2D images, referred to herein as “image frames” or “video image frames.” In some embodiments, a packing module, such as packing module 208, may pack the 2D patch images such that the packed 2D patch images do not overlap (even though an outer bounding box for one patch image may overlap an outer bounding box for another patch image). Also, the packing module may pack the 2D patch images in a way that minimizes non-used images pixels of the image frame.

[0086] In some embodiments, “Geometry/Texture/Attribute generation” modules, such as modules 210, 212, and 214, generate 2D patch images associated with the geometry/texture/attributes, respectively, of the point cloud at a given patch location. As noted before, a packing process, such as performed by packing module 208, may leave some empty spaces between 2D patch images packed in an image frame. Also, a padding module, such as image frame padding module 216, may fill in such areas in order to generate an image frame that may be suited for 2D video and image codecs.

[0087] In some embodiments, an occupancy map (e.g., binary information describing for each pixel or block of pixels whether the pixel or block of pixels are padded or not) may be generated and compressed, for example by occupancy map compression module 220. The occupancy map may be sent to a decoder to enable the decoder to distinguish between padded and non-padded pixels of an image frame.

[0088] Note that other metadata associated with patches may also be sent to a decoder for use in the decompression process. For example, patch information indicating sizes and shapes of patches determined for the point cloud and packed in an image frame may be generated and/or encoded by an auxiliary patch-information compression module, such as auxiliary

patch-information compression module 222. In some embodiments one or more image frames may be encoded by a video encoder, such as video compression module 218. In some embodiments, a video encoder, such as video compression module 218, may operate in accordance with the High Efficiency Video Coding (HEVC) standard or other suitable video encoding standard. In some embodiments, encoded video images, encoded occupancy map information, and encoded auxiliary patch information may be multiplexed by a multiplexer, such as multiplexer 224, and provided to a recipient as compressed point cloud information, such as compressed point cloud information 204.

[0089] In some embodiments, an occupancy map may be encoded and decoded by a video compression module, such as video compression module 218. This may be done at an encoder, such as encoder 200, such that the encoder has an accurate representation of what the occupancy map will look like when decoded by a decoder. Also, variations in image frames due to lossy compression and decompression may be accounted for by an occupancy map compression module, such as occupancy map compression module 220, when determining an occupancy map for an image frame. In some embodiments, various techniques may be used to further compress an occupancy map, such as described in FIGs. 12A-12B.

Example 3D Intra- Frame Decoder

[0090] FIG. 2B illustrates components of a decoder for decoding intra point cloud frames, according to some embodiments. Decoder 230 receives compressed point cloud information 204, which may be the same compressed point cloud information 204 generated by encoder 200. Decoder 230 generates reconstructed point cloud 246 based on receiving the compressed point cloud information 204.

[0091] In some embodiments, a decoder, such as decoder 230, includes a de-multiplexer 232, a video decompression module 234, an occupancy map decompression module 236, and an auxiliary patch-information decompression module 238. Additionally, a decoder, such as decoder 230, includes a point cloud generation module 240, which reconstructs a point cloud based on patch images included in one or more image frames included in the received compressed point cloud information, such as compressed point cloud information 204. In some embodiments, a decoder, such as decoder 203, further comprises a geometry and/or one or

more attribute smoothing filters, such as smoothing filter 244. In some embodiments, a smoothing filter may smooth incongruences at edges of patches, wherein data included in patch images for the patches has been used by the point cloud generation module to recreate a point cloud from the patch images for the patches. In some embodiments, a smoothing filter may be applied to the points located on the patch boundaries to alleviate the distortions that may be caused by the compression/decompression process.

Example 3D Inter-Frame Encoder

[0092] FIG. 2C illustrates components of an encoder for encoding inter point cloud frames, according to some embodiments. An inter point cloud encoder, such as 3D inter point cloud encoder 250, may encode an image frame, while considering one or more previously encoded/decoded image frames as references.

[0093] In some embodiments, an encoder for 3D inter point cloud frames, such as encoder 250, includes a point cloud re-sampling module 252, a 3-D motion compensation and delta vector prediction module 254, a spatial image generation module 256, a texture image generation module 258, and an attribute image generation module 260. In some embodiments, an encoder for 3D inter point cloud frames, such as encoder 250, may also include an image padding module 262 and a video compression module 264. An encoder for inter point cloud frames, such as encoder 250, may generate compressed point cloud information, such as compressed point cloud information 266. In some embodiments, the compressed point cloud information may reference point cloud information previously encoded by the encoder, such as information from or derived from one or more 3D reference frames. In this way an encoder for 3D inter point cloud frames, such as encoder 250, may generate more compact compressed point cloud information by not repeating information included in a 3D reference frame, and instead communicating differences between the 3D reference frames and a current state of the point cloud.

[0094] In some embodiments, an encoder, such as encoder 250, may be combined with or share modules with a 3D intra point cloud frame encoder, such as encoder 200. In some embodiments, a point cloud re-sampling module, such as point cloud re-sampling module 252, may resample points in an input point cloud frame in order to determine a one-to-one mapping

between points in patches of the current image frame and points in patches of a reference image frame for the point cloud. In some embodiments, a 3D motion compensation & delta vector prediction module, such as a 3D motion compensation & delta vector prediction module 254, may apply a temporal prediction to the geometry/texture/attributes of the resampled points of the patches. The prediction residuals may be stored into images, which may be padded and compressed by using video/image codecs. In regard to spatial changes for points of the patches between the reference frame and a current frame, a 3D motion compensation & delta vector prediction module 254, may determine respective vectors for each of the points indicating how the points moved from the reference frame to the current frame. A 3D motion compensation & delta vector prediction module 254, may then encode the motion vectors using different image parameters. For example, changes in the X direction for a point may be represented by an amount of red included at the point in a patch image that includes the point. In a similar manner, changes in the Y direction for a point may be represented by an amount of blue included at the point in a patch image that includes the point. Also, in a similar manner, changes in the Z direction for a point may be represented by an amount of green included at the point in a patch image that includes the point. In some embodiments, other characteristics of an image included in a patch image may be adjusted to indicate motion of points included in the patch between a reference frame for the patch and a current frame for the patch.

Example 3D Inter-Frame Decoder

[0095] FIG. 2D illustrates components of a decoder for decoding 3D inter point cloud frames, according to some embodiments. In some embodiments, a decoder, such as decoder 280, includes a video decompression module 270, an inverse 3D motion compensation and inverse delta prediction module 272, a point cloud generation module 274, and a smoothing filter 276. In some embodiments, a decoder, such as decoder 280 may be combined with a decoder, such as decoder 230, or may share some components with the decoder, such as a video decompression module and/or smoothing filter. In decoder 280, the video/image streams are first decoded, then an inverse motion compensation and delta prediction procedure may be applied. The obtained images are then used in order to reconstruct a point cloud, which may be smoothed as described previously to generate a reconstructed point cloud 282.

[0096] While 3D encoding of a point cloud is discussed above in terms of 3D intra-frame compression/decompression and 3D inter-frame compression/decompression, it should be understood that the intra-prediction and the inter-prediction is in regard to 3D point cloud data. In some embodiments an underlying video encoder that is encoding packed image frames packed with patch images may utilize 2D video intra or inter compression/decompression techniques to compress and decompress the packed image frames regardless of whether the point cloud compression being applied is intra-prediction or inter-prediction. For example, a video encoder may encode sequential packed image frames using an inter-prediction process, even though the patch images packed in the image frames were generated using an intra-compression process in the 3D domain. Also, as another example, a video encoder may encode motion vectors generated as part of a 3D inter-prediction process in the 3D domain using a 2D video intra-prediction process, where the motion vectors themselves are generated in the 3D domain using inter-prediction, but where the video image frames comprising the motion vectors are compressed by the video encoder using intra-prediction processes for the packed video image frames.

Segmentation Process

[0097] FIG. 3A illustrates an example segmentation process for determining patches for a point cloud, according to some embodiments. The segmentation process as described in FIG. 3A may be performed by a decomposition into patches module, such as decomposition into patches module 206. A segmentation process may decompose a point cloud into a minimum number of patches (e.g., a contiguous subset of the surface described by the point cloud), while making sure that the respective patches may be represented by a depth field with respect to a patch plane. This may be done without a significant loss of shape information.

[0098] In some embodiments, a segmentation process comprises:

- Letting point cloud PC be the input point cloud to be partitioned into patches and $\{P(0), P(1), \dots, P(N-1)\}$ be the positions of points of point cloud PC.
- In some embodiments, a fixed set $D = \{D(0), D(1), \dots, D(K-1)\}$ of K 3D orientations is pre-defined. For instance, D may be chosen as follows $D = \{(1.0, 0.0, 0.0), (0.0, 1.0, 0.0), (0.0, 0.0, 1.0), (-1.0, 0.0, 0.0), (0.0, -1.0, 0.0), (0.0, 0.0, -1.0)\}$

- In some embodiments, the normal vector to the surface at every point $P(i)$ is estimated. Any suitable algorithm may be used to determine the normal vector to the surface. For instance, a technique could include fetching the set H of the “ N ” nearest points of $P(i)$, and fitting a plane $\Pi(i)$ to $H(i)$ by using principal component analysis techniques. The normal to $P(i)$ may be estimated by taking the normal $\nabla(i)$ to $\Pi(i)$. Note that “ N ” may be a user-defined parameter or may be found by applying an optimization procedure. “ N ” may also be fixed or adaptive. The normal values may then be oriented consistently by using a minimum-spanning tree approach.
- **Normal-based Segmentation:** An initial segmentation S_0 of the points of point cloud PC may be obtained by associating respective points with the direction $D(k)$ which maximizes the score $\langle \nabla(i) | D(k) \rangle$, where $\langle \cdot | \cdot \rangle$ is the canonical dot product of R^3 . Pseudo code is provided below.

```

for (i = 0; i < pointCount; ++i) {
    clusterIndex = 0;
    bestScore =  $\langle \nabla(i) | D(0) \rangle$ ;
    for(j = 1; j < K; ++j) {
        score =  $\langle \nabla(i) | D(j) \rangle$ ;
        if (score > bestScore) {
            bestScore = score;
            clusterIndex = j;
        }
    }
    partition[i] = clusterIndex;
}

```

- **Iterative segmentation refinement:** Note that segmentation S_0 associates respective points with the plane $\Pi(i)$ that best preserves the geometry of its neighborhood (e.g. the neighborhood of the segment) . In some circumstances, segmentation S_0 may generate too many small connected components with irregular boundaries, which may result in poor compression performance. In order

to avoid such issues, the following iterative segmentation refinement procedure may be applied:

1. An adjacency graph A may be built by associating a vertex $V(i)$ to respective points $P(i)$ of point cloud PC and by adding R edges $\{E(i,j(0)), \dots, E(i,j(R-1))\}$ connecting vertex $V(i)$ to its nearest neighbors $\{V(j(0)), V(j(1)), \dots, V(j(R-1))\}$. More precisely, $\{V(j(0)), V(j(1)), \dots, V(j(R-1))\}$ may be the vertices associated with the points $\{P(j(0)), P(j(1)), \dots, P(j(R-1))\}$, which may be the nearest neighbors of $P(i)$. Note that R may be a user-defined parameter or may be found by applying an optimization procedure. It may also be fixed or adaptive.
2. At each iteration, the points of point cloud PC may be traversed and every vertex may be associated with the direction $D(k)$ that maximizes $\left(\langle \nabla(i) | D(k) \rangle + \frac{\lambda}{R} |\zeta(i)|\right)$, where $|\zeta(i)|$ is the number of the R -nearest neighbors of $V(i)$ belonging to the same cluster and λ is a parameter controlling the regularity of the produced patches. Note that the parameters λ and R may be defined by the user or may be determined by applying an optimization procedure. They may also be fixed or adaptive. In some embodiments, a “user” as referred to herein may be an engineer who configured a point cloud compression technique as described herein to one or more applications.

3. An example of pseudo code is provided below

```

for(l = 0; l < iterationCount; ++l) {
    for(i = 0; i < pointCount; ++i) {
        clusterIndex = partition[i];
        bestScore = 0.0;
        for(k = 0; k < K; ++k) {
            score =  $\langle \nabla(i) | D(k) \rangle$ ;
            for(j  $\in$  {j(0), j(1), ..., j(R - 1)}) {
                if (k == partition[j]) {
                    score +=  $\frac{\lambda}{R}$ ;
                }
            }
            if (score > bestScore) {
                bestScore = score;
                clusterIndex = k;
            }
        }
        partition[i] = clusterIndex;
    }
}

```

*In some embodiments, the pseudo code shown above may further include an early termination step. For example, if a score that is a particular value is reached, or if a difference between a score that is reached and a best score only changes by a certain amount or less, the search could be terminated early. Also, the search could be terminated if after a certain number of iterations ($l=m$), the clusterindex does not change.

- **Patch segmentation:** In some embodiments, the patch segmentation procedure further segments the clusters detected in the previous steps into patches, which may

be represented with a depth field with respect to a projection plane. The approach proceeds as follows, according to some embodiments:

1. First, a cluster-based adjacency graph with a number of neighbors R' is built, while considering as neighbors only the points that belong to the same cluster. Note that R' may be different from the number of neighbors R used in the previous steps.
2. Next, the different connected components of the cluster-based adjacency graph are extracted. Only connected components with a number of points higher than a parameter α are considered. Let $CC = \{CC(0), CC(1), \dots, CC(M-1)\}$ be the set of the extracted connected components.
3. Respective connected component $CC(m)$ inherits the orientation $D(m)$ of the cluster it belongs to. The points of $CC(m)$ are then projected on a projection plane having as normal the orientation $D(m)$, while updating a depth map, which records for every pixel the depth of the nearest point to the projection plane.
4. An approximated version of $CC(m)$, denoted $C'(m)$, is then built by associating respective updated pixels of the depth map with a 3D point having the same depth. Let PC' be the point cloud obtained by the union of reconstructed connected components $\{CC'(0), CC'(1), \dots, CC'(M-1)\}$
5. Note that the projection reconstruction process may be lossy and some points may be missing. In order, to detect such points, every point $P(i)$ of point cloud PC may be checked to make sure it is within a distance lower than a parameter δ from a point of PC' . If this is not the case, then $P(i)$ may be marked as a missed point and added to a set of missed points denoted MP .
6. The steps 2-5 are then applied to the missed points MP . The process is repeated until MP is empty or CC is empty. Note that the parameters δ and α may be defined by the user or may be determined by applying an optimization procedure. They may also be fixed or adaptive.
7. A filtering procedure may be applied to the detected patches in order to make them better suited for compression. Example filter procedures may include:

- a. A smoothing filter based on the geometry/texture/attributes of the points of the patches (e.g., median filtering), which takes into account both spatial and temporal aspects.
- b. Discarding small and isolated patches.
- c. User-guided filtering.
- d. Other suitable smoothing filter techniques.

Layers

[0099] The image generation process described above consists of projecting the points belonging to each patch onto its associated projection plane to generate a patch image. This process could be generalized to handle the situation where multiple points are projected onto the same pixel as follows:

- Let $H(u, v)$ be the set of points of the current patch that get projected to the same pixel (u, v) . Note that $H(u, v)$ may be empty, may have one point or multiple points.
- If $H(u, v)$ is empty then the pixel is marked as unoccupied.
- If the $H(u, v)$ has a single element, then the pixel is filled with the associated geometry/texture/attribute value.
- If $H(u, v)$, has multiple elements, then different strategies are possible:
 - Keep only the nearest point $P_0(u, v)$ for the pixel (u, v)
 - Take the average or a linear combination of a group of points that are within a distance d from $P_0(u, v)$, where d is a user-defined parameter needed only on the encoder side.
 - Store two images: one for $P_0(u, v)$ and one to store the furthest point $P_1(u, v)$ of $H(u, v)$ that is within a distance d from $P_0(u, v)$
 - Store N patch images containing a subset of $H(u, v)$

[00100] The generated patch images for point clouds with points at the same patch location, but different depths may be referred to as layers herein. In some embodiments, scaling/up-sampling/down-sampling could be applied to the produced patch images/layers in order to control the number of points in the reconstructed point cloud.

[00101] Guided up-sampling strategies may be performed on the layers that were down-sampled given the full resolution image from another “primary” layer that was not down-sampled.

[00102] In some embodiments, a delta prediction between layers could be adaptively applied based on a rate-distortion optimization. This choice may be explicitly signaled in the bit stream.

[00103] In some embodiments, the generated layers may be encoded with different precisions. The precision of each layer may be adaptively controlled by using a shift + scale or a more general linear or non-linear transformation.

[00104] In some embodiments, an encoder may make decisions on a scaling strategy and parameters, which are explicitly encoded in the bit stream. The decoder may read the information from the bit stream and apply the right scaling process with the parameters signaled by the encoder.

[00105] In some embodiments, a video encoding motion estimation process may be guided by providing a motion vector map to the video encoder indicating for each block of the image frame, a 2D search center or motion vector candidates for the refinement search. Such information, may be trivial to compute since the mapping between the 3D frames and the 2D image frames is available to the point cloud encoder and a coarse mapping between the 2D image frames could be computed by using a nearest neighbor search in 3D.

[00106] The video motion estimation/mode decision/intra-prediction could be accelerated/improved by providing a search center map, which may provide guidance on where to search and which modes to choose from for each $N \times N$ pixel block.

[00107] Hidden/non-displayed pictures could be used in codecs such as AV1 and HEVC. In particular, synthesized patches could be created and encoded (but not displayed) in order to improve prediction efficiency. This could be achieved by re-using a subset of the padded pixels to store synthesized patches.

[00108] The patch re-sampling (e.g., packing and patch segmentation) process described above exploits solely the geometry information. A more comprehensive approach may take into account the distortions in terms of geometry, texture, and other attributes and may improve the quality of the re-sampled point clouds.

[00109] Instead of first deriving the geometry image and optimizing the texture image given said geometry, a joint optimization of geometry and texture could be performed. For example, the geometry patches could be selected in a manner that results in minimum distortion for both geometry and texture. This could be done by immediately associating each possible geometry patch with its corresponding texture patch and computing their corresponding distortion information. Rate-distortion optimization could also be considered if the target compression ratio is known.

[00110] In some embodiments, a point cloud resampling process described above may additionally consider texture and attributes information, instead of relying only on geometry.

[00111] Also, a projection-based transformation that maps 3D points to 2D pixels could be generalized to support arbitrary 3D to 2D mapping as follows:

- Store the 3D to 2D transform parameters or the pixel coordinates associated with each point
- Store X, Y, Z coordinates in the geometry images instead of or in addition to the depth information

Packing

[00112] In some embodiments, depth maps associated with patches, also referred to herein as “depth patch images” or “geometry patch images,” such as those described above, may be packed into a 2D image frame. For example, a packing module, such as packing module 208, may pack depth patch images generated by a spatial image generation module, such as spatial image generation module 210. The depth maps, or depth patch images, may be packed such

that (A) no non-overlapping block of $T \times T$ pixels contains depth information from two different patches and such that (B) a size of the generated image frame is minimized.

[00113] In some embodiments, packing comprises the following steps:

- a. The patches are sorted by height and then by width. The patches are then inserted in image frame (I) one after the other in that order. At each step, the pixels of image frame (I) are traversed in raster order, while checking if the current patch could be inserted under the two conditions (A) and (B) described above. If it is not possible then the height of (I) is doubled.
- b. This process is iterated until all the patches are inserted.

[00114] In some embodiments, the packing process described above may be applied to pack a subset of the patches inside multiples tiles of an image frame or multiple image frames. This may allow patches with similar/close orientations based on visibility according to the rendering camera position to be stored in the same image frame/tile, to enable view-dependent streaming and/or decoding. This may also allow parallel encoding/decoding.

[00115] In some embodiments, the packing process can be considered a bin-packing problem and a first decreasing strategy as described above may be applied to solve the bin-packing problem. In other embodiments, other methods such as the modified first fit decreasing (MFFD) strategy may be applied in the packing process.

[00116] In some embodiments, if temporal prediction is used, such as described for inter compression encoder 250, such an optimization may be performed with temporal prediction/encoding in addition to spatial prediction/encoding. Such consideration may be made for the entire video sequence or per group of pictures (GOP). In the latter case additional constraints may be specified. For example, a constraint may be that the resolution of the image frames should not exceed a threshold amount. In some embodiments, additional temporal constraints may be imposed, even if temporal prediction is not used, for example such as that a patch corresponding to a particular object view is not moved more than x number of pixels from previous instantiations.

[00117] FIG. 3B illustrates an example image frame comprising packed patch images and padded portions, according to some embodiments. Image frame 300 includes patch images 302 packed into image frame 300 and also includes padding 304 in space of image frame 300 not occupied by patch images. In some embodiments, padding, such as padding 304, may be determined so as to minimize incongruences between a patch image and the padding. For example, in some embodiments, padding may construct new pixel blocks that are replicas of, or are to some degree similar to, pixel blocks that are on the edges of patch images. Because an image and/or video encoder may encode based on differences between adjacent pixels, such an approach may reduce the number of bytes required to encode an image frame comprising of patch images and padding, in some embodiments.

[00118] In some embodiments, the patch information may be stored in the same order as the order used during the packing, which makes it possible to handle overlapping 2D bounding boxes of patches. Thus a decoder receiving the patch information can extract patch images from the image frame in the same order in which the patch images were packed into the image frame. Also, because the order is known by the decoder, the decoder can resolve patch image bounding boxes that overlap.

[00119] FIG. 3C illustrates an example image frame 312 with overlapping patches, according to some embodiments. FIG. 3C shows an example with two patches (patch image 1 and patch image 2) having overlapping 2D bounding boxes 314 and 316 that overlap at area 318. In order to determine to which patch the TxT blocks in the area 318 belong, the order of the patches may be considered. For example, the TxT block 314 may belong to the last decoded patch. This may be because in the case of an overlapping patch, a later placed patch is placed such that it overlaps with a previously placed patch. By knowing the placement order it can be resolved that areas of overlapping bounding boxes go with the latest placed patch. In some embodiments, the patch information is predicted and encoded (e.g., with an entropy/arithmetic encoder). Also, in some embodiments, U_0 , V_0 , DU_0 and DV_0 are encoded as multiples of T , where T is the block size used during the padding phase.

[00120] FIG. 3C also illustrates blocks of an image frame 312, wherein the blocks may be further divided into sub-blocks. For example block A1, B1, C1, A2, etc. may be divided into multiple sub-blocks, and, in some embodiments, the sub-blocks may be further divided into

smaller blocks. In some embodiments, a video compression module of an encoder, such as video compression module 218 or video compression module 264, may determine whether a block comprises active pixels, non-active pixels, or a mix of active and non-active pixels. The video compression module may budget fewer resources to compress blocks comprising non-active pixels than an amount of resources that are budgeted for encoding blocks comprising active pixels. In some embodiments, active pixels may be pixels that include data for a patch image and non-active pixels may be pixels that include padding. In some embodiments, a video compression module may sub-divide blocks comprising both active and non-active pixels, and budget resources based on whether sub-blocks of the blocks comprise active or non-active pixels. For example, blocks A1, B1, C1, A2 may comprise non-active pixels. As another example block E3 may comprise active pixels, and block B6, as an example, may include a mix of active and non-active pixels.

[00121] In some embodiments, a patch image may be determined based on projections, such as projecting a point cloud onto a cube, cylinder, sphere, etc. In some embodiments, a patch image may comprise a projection that occupies a full image frame without padding. For example, in a cubic projection each of the six cubic faces may be a patch image that occupies a full image frame.

[00122] For example, FIG. 3D illustrates a point cloud being projected onto multiple projections, according to some embodiments.

[00123] In some embodiments, a representation of a point cloud is encoded using multiple projections. For example, instead of determining patches for a segment of the point cloud projected on a plane perpendicular to a normal to the segment, the point cloud may be projected onto multiple arbitrary planes or surfaces. For example, a point cloud may be projected onto the sides of a cube, cylinder, sphere, etc. Also multiple projections intersecting a point cloud may be used. In some embodiments, the projections may be encoded using conventional video compression methods, such as via a video compression module 218 or video compression module 264. In particular, the point cloud representation may be first projected onto a shape, such as a cube, and the different projections/faces projected onto that shape (i.e. front (320), back (322), top (324), bottom (326), left (328), right (330)) may all be packed onto a single

image frame or multiple image frames. This information, as well as depth information may be encoded separately or with coding tools such as the ones provided in the 3D extension of the HEVC (3D-HEVC) standard. The information may provide a representation of the point cloud since the projection images can provide the (x,y) geometry coordinates of all projected points of the point cloud. Additionally, depth information that provides the z coordinates may be encoded. In some embodiments, the depth information may be determined by comparing different ones of the projections, slicing through the point cloud at different depths. When projecting a point cloud onto a cube, the projections might not cover all point cloud points, e.g. due to occlusions. Therefore additional information may be encoded to provide for these missing points and updates may be provided for the missing points.

[00124] In some embodiments, adjustments to a cubic projection can be performed that further improve upon such projections. For example, adjustments may be applied at the encoder only (non-normative) or applied to both the encoder and the decoder (normative).

[00125] More specifically, in some embodiments alternative projections may be used. For example, instead of using a cubic projection, a cylindrical or spherical type of a projection method may be used. Such methods may reduce, if not eliminate, redundancies that may exist in the cubic projection and reduce the number or the effect of “seams” that may exist in cubic projections. Such seams may create artifacts at object boundaries, for example. Eliminating or reducing the number or effect of such seams may result in improved compression/subjective quality as compared to cubic projection methods. For a spherical projection case, a variety of sub-projections may be used, such as the equirectangular, equiangular, and authagraph projection among others. These projections may permit the projection of a sphere onto a 2D plane. In some embodiments, the effects of seams may be de-emphasized by overlapping projections, wherein multiple projections are made of a point cloud, and the projections overlap with one another at the edges, such that there is overlapping information at the seams. A blending effect could be employed at the overlapping seams to reduce the effects of the seams, thus making them less visible.

[00126] In addition to, or instead of, considering a different projection method (such as cylindrical or spherical projections), in some embodiments multiple parallel projections may be used. The multiple parallel projections may provide additional information and may reduce a number of occluded points. The projections may be known at the decoder or signaled to the

decoder. Such projections may be defined on planes or surfaces that are at different distances from a point cloud object. Also, in some embodiments the projections may be of different shapes, and may also overlap or cross through the point cloud object itself. These projections may permit capturing some characteristics of a point cloud object that may have been occluded through a single projection method or a patch segmentation method as described above.

[00127] For example, FIG. 3E illustrates a point cloud being projected onto multiple parallel projections, according to some embodiments. Point cloud 350 which includes points representing a coffee mug is projected onto parallel horizontal projections 352 that comprise planes orthogonal to the Z axis. Point cloud 350 is also projected onto vertical projections 354 that comprise planes orthogonal to the X axis, and is projected onto vertical projections 356 that comprise planes orthogonal to the Y axis. In some embodiments, instead of planes, multiple projections may comprise projections having other shapes, such as multiple cylinders or spheres.

Generating Images Having Depth

[00128] In some embodiments, only a subset of the pixels of an image frame will be occupied and may correspond to a subset of 3D points of a point cloud. Mapping of patch images may be used to generate geometry, texture, and attribute images, by storing for each occupied pixel the depth/texture/attribute value of its associated point.

[00129] In some embodiments, spatial information may be stored with various variations, for example spatial information may:

- a. Store depth as a monochrome image.
- b. Store depth as Y and keep U and V empty (where YUV is a color space, also RGB color space may be used).
- c. Store depth information for different patches in different color planes Y, U and V, in order to avoid inter-patch contamination during compression and/or improve compression efficiency (e.g., have correlated patches in the same color plane). Also, hardware codec capabilities may be utilized, which may spend the same encoding\decoding time independently of the content of the frame.

- d. Store depth patch images on multiple images or tiles that could be encoded and decoded in parallel. One advantage is to store depth patch images with similar/close orientations or based on visibility according to the rendering camera position in the same image/tile, to enable view-dependent streaming and/or decoding.
- e. Store depth as Y and store a redundant version of depth in U and V.
- f. Store X, Y, Z coordinates in Y, U, and V
- g. Different bit depth (e.g., 8, 10 or 12-bit) and sampling (e.g., 420, 422, 444 ...) may be used. Note that different bit depth may be used for the different color planes.

Padding

[00130] In some embodiments, padding may be performed to fill the non-occupied pixels with values such that the resulting image is suited for video/image compression. For example, image frame padding module 216 or image padding module 262 may perform padding as described below.

[00131] In some embodiments, padding is applied on pixels blocks, while favoring the intra-prediction modes used by existing video codecs. More precisely, for each block of size BxB to be padded, the intra prediction modes available at the video encoder side are assessed and the one that produces the lowest prediction errors on the occupied pixels is retained. This may take advantage of the fact that video/image codecs commonly operate on pixel blocks with pre-defined sizes (e.g., 64x64, 32x32, 16x16...). In some embodiments, other padding techniques may include linear extrapolation, in-painting techniques, or other suitable techniques.

Video Compression

[00132] In some embodiments, a video compression module, such as video compression module 218 or video compression module 264, may perform video compression as described below.

[00133] In some embodiments, a video encoder may leverage an occupancy map, which describes for each pixel of an image whether it stores information belonging to the point cloud or padded pixels. In some embodiments, such information may permit enabling various

features adaptively, such as de-blocking, adaptive loop filtering (ALF), or shape adaptive offset (SAO) filtering. Also, such information may allow a rate control module to adapt and assign different, e.g. lower, quantization parameters (QPs), and in an essence a different amount of bits, to the blocks containing the occupancy map edges. Coding parameters, such as lagrangian multipliers, quantization thresholding, quantization matrices, etc. may also be adjusted according to the characteristics of the point cloud projected blocks. In some embodiments, such information may also enable rate distortion optimization (RDO) and rate control/allocation to leverage the occupancy map to consider distortions based on non-padded pixels. In a more general form, weighting of distortion may be based on the “importance” of each pixel to the point cloud geometry. Importance may be based on a variety of aspects, e.g. on proximity to other point cloud samples, directionality/orientation/position of the samples, etc. Facing forward samples, for example, may receive a higher weighting in the distortion computation than backward facing samples. Distortion may be computed using metrics such as Mean Square or Absolute Error, but different distortion metrics may also be considered, such as SSIM, VQM, VDP, Hausdorff distance, and others.

[00134] Also, in some embodiments, such encoders and decoders or other encoders and decoders as described herein may be adapted for other visual volumetric content, including meshes, three-degree of freedom plus (3DOF+) scenes or as alternatively referred to in some contexts as MPEG MIV material, lightfields, or other types of six-degree of freedom (6DOF) content.

Occupancy Map Compression

[00135] In some embodiments, an occupancy map compression module, such as occupancy map compression module 220, may compress an occupancy map as described below.

Example Occupancy Map Compression Techniques

[00136] In some embodiments, an occupancy map may be encoded in a hierarchical mode. Such a process may comprise:

1. A binary information for each B1xB2 pixel block (e.g., a rectangle that covers the entire image frame, or smaller blocks of different sizes such as 64x64, 64x32, 32x32

block, etc.) being encoded indicating whether the block is empty (e.g., has only padded pixels) or non-empty (e.g., has non-padded pixels).

2. If the block is non-empty, then a second binary information may be encoded to indicate whether the block is full (e.g., all the pixels are non-padded) or not.
3. The non-empty and non-full blocks may then be refined by considering their $(B1/2) \times (B2/2)$ sub-blocks.
4. The steps 1-3 may be repeated until the size of the block reaches a certain block size $B3 \times B4$ (e.g., of size 4×4). At this level only the empty/non-empty information may be encoded.
5. An entropy-based codec may be used to encode the binary information in steps 1 and 2. For instance, context adaptive binary arithmetic encoders may be used.
6. The reconstructed geometry image may be leveraged to better encode the occupancy map. More precisely, the residual prediction errors may be used to predict whether a block is empty or not or full or not. Such an information may be incorporated by using a different context based on the predicted case or simply by encoding the binary value XORed with the predicted value.

[00137] In some embodiments, mesh-based codecs may be an alternative to the approach described above.

Additional Example Occupancy Map Compression Technique

[00138] In some embodiments, auxiliary information and the patch encoding order may be leveraged in order to efficiently compress a mapping information indicating for each TxT block of an image frame (e.g., 16×16 block) to which patch it belongs to. This mapping may be explicitly encoded in the bit stream as follows:

- A list of candidate patches is created for each TxT block of an image frame by considering all the patches that overlap with that block.

- The list of candidates is sorted in the reverse order of the patches. Meaning the candidate patches are ordered from smallest patch to largest patch.
- For each block, the index of the patches in this list is encoded by using an arithmetic or other form of an entropy encoder (e.g. UVLC or Huffman based).
- Note that empty blocks are assigned a special index, such as zero.
- The mapping information described above makes it possible to detect empty TxT blocks of an image frame (e.g., blocks that contain only padded pixels). The occupancy information is encoded only for the non-empty TxT blocks (e.g., the blocks that contain at least one non-padded pixel).
- The occupancy map is encoded with a precision of a $B_0 \times B_0$ blocks. In order to achieve lossless encoding B_0 is chosen to be 1. In some embodiments $B_0=2$ or $B_0=4$, which may result in visually acceptable results, while significantly reducing the number of bits required to encode the occupancy map.
- Binary values are associated with $B_0 \times B_0$ sub-blocks belonging to the same TxT block. Different strategies are possible. For instance, one could associate a value of 1 if the sub-block contains at least some non-padded pixels and 0 otherwise. If a sub-block has a value of 1 it is said to be full, otherwise it is an empty sub-block.
- If all the sub-blocks of a TxT block are full (e.g., have value 1). The block is said to be full. Otherwise, the block is said to be non-full.
- A binary information is encoded for each TxT block to indicate whether it is full or not. Various encoding strategies could be used. For instance, a context adaptive binary arithmetic encoder could be used.
- If the block is non-full, an extra information is encoded indicating the location of the full/empty sub-blocks. More precisely, the process may proceed as follows:
 - Different traversal orders are defined for the sub-blocks. Figure 12B, shows some examples. The traversal orders are predetermined and known to both the encoder and decoder.
 - The encoder chooses one of the traversal orders and explicitly signals its index in the bit stream.
 - The binary values associated with the sub-blocks are encoded by using a run-length encoding strategy.

- The binary value of the initial sub-block is encoded. Various encoding strategies could be used. For instance, fixed length coding or a context adaptive binary arithmetic encoder could be used.
- Continuous runs of 0s and 1s are detected, while following the traversal order selected by the encoder.
- The number of detected runs is encoded. Various encoding strategies could be used. For instance, fixed length coding or a context adaptive binary arithmetic encoder, or a universal variable length encoder (UVLC) could be used.
- The length of each run, except of the last one, is then encoded. Various encoding strategies could be used. For instance, fixed length coding, a context adaptive binary arithmetic encoder, or a universal variable length encoder could be used.

[00139] Note that the symbol probabilities used during the arithmetic encoding could be initialized by using values explicitly signaled in the bit stream by the encoder in order to improve compression efficiency. Such information could be signaled at frame, slice, row(s) of blocks, or block level, or using a non-fixed interval. In that case, a system may have the ability to signal the initialization interval, or the interval adaptation could be predefined between encoder and decoder. For example, the interval could start with one block, and then increment by one block afterwards (e.g. using an adaptation positions of {1, 2, 3... N-1...} blocks).

[00140] The choice of the traversal order may have a direct impact on the compression efficiency. Different strategies are possible. For instance, the encoder could choose the traversal order, which would result in the lowest number of bits or the lowest number of runs. In some embodiments, hierarchical sub-blocks with variable sizes may be used.

[00141] In some embodiments, temporal prediction may be used for encoding/compressing occupancy maps as follows:

- a. The occupancy map of the current frame may be predicted from the occupancy map of a reference frame (e.g. through a difference process assuming zero motion). The prediction could be done at the frame level, but could also be done at a sub-block level, e.g. signal 1 bit whether a block will be predicted temporally, or the original map for a block will be used instead.

- b. Prediction could be enhanced by using motion compensation and by associating a motion vector with each TxT block.
- c. The values of the current block may be XOR-ed with the values of the block referenced by the motion vector or the co-located block. If no prediction is used, the current block may be coded as is.
- d. Motion vectors could be integer, integer multiples, or can have sub-pixel precision.
- e. The encoding strategy described above may be applied to the results.
- f. The motion vectors of the current block may be predicted based on the motion vectors of the previously encoded blocks. For example, a list of candidate predicted motion vectors may be computed based on the motion vectors of spatially and/or temporally neighboring blocks that have already been encoded. The index of the best candidate to be used as a predictor and the difference can be explicitly encoded in the bit stream. The process may be similar to the process used in codecs such as AVC and HEVC among others. A reduction in temporal candidates may be performed similar to what is done in HEVC to reduce memory requirements. The residual motion vector can then be encoded using a technique such as context adaptive arithmetic encoding or UVLC.
- g. A skip mode may also be supported to indicate that the predicted block matches exactly the reference block. In that case, no residual motion vector is needed.
- h. Different block sizes could be used instead of sticking with TxT blocks.
- i. The choice of the block size and the motion vectors could be achieved by minimizing the number of bits required to encode the occupancy map.
- j. The process could also consider multiple references.

[00142] In some embodiments, additional techniques for encoding/compression of an occupancy map may include:

- Using clues included in the video picture to help encode the occupancy map, such as:
 - Use high quantization parameters QPs (e.g., 51) or use skip mode for blocks composed of padded pixels only.
 - The arithmetic encoding contexts could be adaptively adjusted based on information extracted from the video bit streams associated with the texture/geometry/motion frames.

- Group the binary values associated with pixels into 8-bit or 10-bit words and encode them with dictionary-based approaches such as the DEFLATE algorithm.
 - Pixels could be grouped 4x2/5x2 blocks or by leveraging a zig zag scan.
 - Only the pixels belonging to non-empty TxT blocks may be encoded.
 - The mapping information indicating for each TxT block to which patch it belongs may be encoded.

Additional Example Occupancy Map Compression Techniques

[00143] In some embodiments, a binary occupancy map is generated based on whether or not blocks of the occupancy map are occupied or un-occupied. This may be performed in a similar manner as described above. Also, the patch information (e.g. bounding box position, size, etc.) is encoded using an arithmetic encoder, in a similar manner as described above. However, instead of relying on the occupancy map to discard empty blocks that intersect with at least one patch bounding box, the empty boxes are explicitly signaled with a special value for the local index. In this approach, the block to patch information is decoded when needed.

[00144] In some embodiments, instead of using an arithmetic encoder as described above to encode block to patch information that links boxes of the occupancy map with particular patches, the block to patch information (which contains the local indexes) may be encoded using a video-based encoder. The encoded block-to patch information may then be decoded using a corresponding video-decoder.

[00145] In some embodiments, instead of generating a binary occupancy map based on whether or not blocks of the occupancy map are occupied or un-occupied, a non-binary occupancy map is generated. The non-binary occupancy map is configured such that each pixel not only indicates whether the pixel is occupied or non-occupied, but also includes an attribute value, such as a color value that is associated with a local index value of a patch with which the pixel is associated. If the pixel is non-occupied, the pixel may have a color value of zero. Also, the patch information (e.g. bounding box position, size, etc.) is encoded using an arithmetic encoder, in a similar manner as described above. The non-binary occupancy map may be encoded using a video-based encoder. A decoder can retrieve the block to patch

information by decoding the non-binary occupancy map and matching each pixel value with the local index lists.

[00146] In some embodiments, instead of using a local index, a full list of patches may be used as an index. In such embodiments, there may be no need to compute a list of candidate patches for each block. The decoder can retrieve the block-to-patch information by decoding the non-binary occupancy map directly reading the index value for the patch associated with the pixel from the value of the pixel. In such embodiments, the local index may be omitted because there are enough unique values (e.g. non-binary) values available to be associated with a block, such that each candidate patch may be assigned a unique value.

[00147] In some embodiments, during the generation of the occupancy map, the bounding boxes for the patches may be adjusted or initially packed in an image frame such that the bounding boxes do not overlap. This removes ambiguity as to whether a particular bounding box belongs to a particular patch or another patch. The patch information (with non-overlapping bounding boxes) is encoding using an arithmetic encoder. Because there is not ambiguity as to which patch goes with which bounding box, the block to patch information (such as in the local index or complete index, as described above), may be omitted.

[00148] In some embodiments, a process that uses a full list of patches (instead of a local index) may result in a high number of patches, which may exceed the max possible number of values (e.g. color values) that may be represented in the non-binary occupancy map. In some embodiments, to address such issues, an occupancy map may be decomposed into segments, with a limited number of patches per segments. Thus for each segment, the patch index is bound. For example, fewer patches may be listed as possibilities for a segment of an occupancy map, such that for each segment the list of possible patches is less than the max possible number of values (e.g. color values). In some such embodiments, bounding boxes for different patches may be allowed to overlap within a segment, but not across segments. During decoding, each segment may have its own global index list of possible patches for that segment.

[00149] In some embodiments, a binary occupancy map is generated such that when the patches are packed in the image frame, a bounding box of the patch, aligned to an occupancy resolution does not intersect any previously packed patches of size=occupancy

resolution*size occupancy resolution (e.g. a 16X16 block). The patch information (e.g. bounding box position and size) for each patch is encoded using an arithmetic encoder. The order in which the patch information for each patch is encoded may create a hierarchy of patches, such that for any overlapping bounding boxes, the corresponding patch that goes with the bound box can be resolved based on the hierarchy of patch information. The decoder may reconstruct block to patch information using the arithmetically encoded patch information (without the block to patch information being explicitly encoded). For example, a patch list may be parsed in a same order at a decoder as an order in which the patch list was generated at encoding time, wherein the order indicates an order in which the patches were packed in the image frame. This is possible because the packing guarantees that the bounding box for a given patch does not cover any previously processed patch. In such embodiments, patches may be packed (and signaled) in an order such as from small to large, or vice versa. During the packing, each block may include pixels of just one patch, but some bounding boxes for multiple patches may overlap, wherein blocks of the overlapping patches include no pixels for either patch, or pixels for just one of the patches, but not pixels for more than one patch.

Auxiliary Patch-Information Compression

[00150] In some embodiments, for each patch, the following information may be encoded. For example, by auxiliary patch-info compression module 222.

- Its location (U0, V0) in the packed image frame and the extent of its 2D bounding box (DU0, DV0).
- Minimum/maximum/average/median depth value.
- Index of the projection direction.

Video-Based Occupancy Map Compression

[00151] As described above, in some embodiments, the occupancy map is a binary information that indicates for each pixel in the image frame whether the pixel should be interpreted as an actual point in the point cloud or not, e.g. the pixel is a padded pixel or not. Also, as described above, the auxiliary patch-information indicates for each TxT block of an image frame to which patch it belongs. Whereas it was described above to encode an index of patches for a block of an image frame and to keep encoding information for sub-blocks of the

image frame until the sub-blocks were either fully empty or fully occupied, an alternative approach is to use a video encoder to encode an additional image frame for the occupancy map. In such embodiments, the additional occupancy map image frame, indicates occupied and unoccupied pixels based on image properties such as different colors (e.g. occupied pixels may be white and non-occupied pixels may be black). In this way it is not necessary to completely subdivide the blocks of the image frame until only occupied or un-occupied sub-blocks are determined. Instead, it is only necessary to identify bounding box sizes and locations in the image frame for the respective patches. The video encoded occupancy map will mirror the image frame and the different pixel values in the occupancy map video image frame will indicate which pixels in a given bounding box of the patch video image frame are patch image pixels or are padded pixels. Thus there is not a need to create a bit stream of sub-divided blocks of the image frame and there is not a need to indicate for each sub-block whether the sub-block is full or empty. Instead the video encoded occupancy map can be used to determine which pixels included in a patch bounding box are padded pixels or patch image pixels. In some embodiments, an occupancy map may be first encoded and then used to generate an index of patches that are associated with blocks of an image frame. In some embodiments, a compression process follows the following procedure that leverages existing video codecs to compress an occupancy map.

[00152] The occupancy map could be encoded with a precision of $B_0 \times B_1$ blocks. In order to achieve lossless encoding B_0 and B_1 may be chosen to be equal to 1. In practice $B_0=B_1=2$ or $B_0=B_1=4$ may result in visually acceptable results, while significantly reducing the number of bits required to encode the occupancy map.

[00153] In some embodiments, a single binary is associated with each $B_0 \times B_1$ sub-block. Different strategies are possible. For instance, one could associate a value of 1 with the rule that the sub-block contains at least one non-padded pixel and the value of 0 if not. In order to reduce computational complexity, the binary values of multiple $B_0 \times B_1$ blocks could be grouped together in a single pixel value.

[00154] A binary video frame may be generated by storing the value of each $B_0 \times B_1$ block in a pixel. The obtained video frame could be compressed by using a lossless video

codec. For example the HEVC video codec could be utilized and its main, screen context coding (scc) main or other profiles could be used.

[00155] In some embodiments, the occupancy map could be packed in a 4:4:4 or 4:2:0 chroma format, where the chroma information could contain fixed values, e.g. the values 0 or 128 for an 8 bit codec. The occupancy map could also be coded using a codec supporting a monochrome representation. The occupancy map could be replicated in all color components and encoded using a 4:4:4 representation. Other rearrangements of the occupancy map could be used so as to fit the data in a 4:4:4, 4:2:2, or 4:2:0 representation, while preserving the lossless nature of the signal and at the same time preserving the lossless characteristics of the occupancy map. For example, the occupancy map could be segmented to even horizontal and odd horizontal position sub-maps, and those sub-maps could be embedded into a 4:4:4 signal, the odd position samples in the Y plane and the even position samples in the U plane, and then encoded. This could provide savings in complexity since a reduced resolution (by half) image would be encoded. Other such arrangements could be used.

[00156] The occupancy map is used to detect non-empty TxT blocks and only for those blocks a patch index is encoded by proceeding as follows:

- 1) A list of candidate patches is created for each TxT block by considering all the patches that contain that block.
- 2) The list of candidates is sorted in the reverse order of the patches. Meaning the index is sorted from smallest patch to largest patch, e.g. the patches with bounding boxes covering the smallest area are ordered ahead of patches with bounding boxes covering larger areas of the patch image frame.
- 3) For each block, the index of the patch in this list is encoded by using an entropy encoder, e.g. an arithmetic encoder or other suitable encoder.

Patch Alignment and Size Determination in a 2D Bounding Box of an Occupancy Map

[00157] In some embodiments, methods may be applied to remove redundant output points created by the occupancy map quantization/downsampling/upsampling process. By removing these points, the reconstruction process can result in better reconstruction. Furthermore, fewer points may need to be processed during post-processing, e.g. when

performing smoothing as described below, thus reducing reconstruction complexity as well as during attribute image generation during encoding. Additionally, quality of the "removed" points in the geometry and attribute layers may be less important, therefore the characteristics of such points may be exploited during compression, such as devoting fewer resources to redundant points that will be removed.

[00158] In some embodiments, when a patch is created, the patch size information (e.g. sizeU0, sizeV0) is defined as multiples of the occupancy packing block. In other words, when patch size is NxM and the occupancy packing block resolution is 16, sizeU0 and sizeV0 will be (16*(N/16+1), 16*(M/16+1)). For example, Table 1 shows an example algorithm for determining the width and width of a 2D bounding box for a patch.

Table 1: Width and Height of Patch Derivation

<p>If p is equal to 0, then: Patch2dSizeU[frmlDx][p] = pdu_2d_delta_size_u[frmlDx][p] * ops_occupancy_packing_block_size (8-8) Patch2dSizeV[frmlDx][p] = pdu_2d_delta_size_v[frmlDx][p] * ops_occupancy_packing_block_size (8-9) Otherwise, if (p > 0), then: Patch2dSizeU[frmlDx][p] = Patch2dSizeU[frmlDx][p - 1] + pdu_2d_delta_size_u[frmlDx][p] * ops_occupancy_packing_block_size (8-10) Patch2dSizeV[frmlDx][p] = Patch2dSizeV[frmlDx][p - 1] + pdu_2d_delta_size_v[frmlDx][p] * ops_occupancy_packing_block_size (8-11)</p>

[00159] In some embodiments, in a patch bounding box, there could be "empty" lines and/or columns maximum equal to (occupancy packing block resolution -1).

[00160] In some embodiments, an occupancy map could be quantized/downsampled by oPrecision which can be derived from the decoded occupancy map video resolution and the nominal resolution of the decoded video frames and then dequantized/upsampled when it is used. Therefore, (oPrecision x oPrecision) pixels will share one same value (1. Occupied 0. Empty). When the (oPrecision x oPrecision) pixels were not fully filled with 1 before the quantization process, the dequantization process will mark previously empty pixels with redundant points, and it would add on the distortion and complexity of the point cloud.

[00161] A method which simply discards samples that would have otherwise created additional points may result in holes or crack during reconstruction of the point cloud. A method which moves occupied samples to reduce redundant pixels may, for irregular shapes, result in redundant pixels.

[00162] In some embodiments, to improve upon such methods and to remove redundant output points, the width, height, and placement of a patch in an occupancy map may be adjusted.

Point Cloud Resampling

[00163] In some embodiments, a point cloud resampling module, such as point cloud resampling module 252, may resample a point cloud as described below.

[00164] In some embodiments, dynamic point clouds may have a different number of points from one frame to another. Efficient temporal prediction may require mapping the points of the current frame, denoted CF, to the points of a reference frame, denoted RF. Signaling such a mapping in a bit stream may require a high number of bits and thus may be inefficient. Instead, re-sampling of a current frame CF may be performed so that the current frame CF has the same number of points as reference frame RF. More precisely, the points of reference frame RF may be displaced such that its shape matches the shape of current frame CF. As a second step, the color and attributes of current frame CF may be transferred to the deformed version of reference frame RF. The obtained frame CF' may be considered as the re-sampled version of the current frame. The decision to compress the approximation CF' of CF may be made by comparing the rate distortion costs of both options (e.g., encoding CF' as inter-frame vs. encoding CF as intra-frame). In some embodiments, pre-adjusting RF may be performed in an effort to make it a better reference for future CF images. Resampling may comprise the following:

- a. First, normals of the points associated with current frame CF and reference frame RF may be estimated and oriented consistently. For every point P belonging to current frame CF (resp. Q belonging to RF), let $\alpha(P)$ (resp., $\alpha(Q)$) be its position and $\nabla(P)$ (resp., $\nabla(Q)$) its normal. A 6D vector, denoted $v(P)$ (resp., $v(Q)$) is then associated with every point by combining its position and a weighted version of its normal in the same vector.

$$v(P) = \begin{bmatrix} \alpha(P) \\ \varepsilon \nabla(P) \end{bmatrix} \quad v(Q) = \begin{bmatrix} \alpha(Q) \\ \varepsilon \nabla(Q) \end{bmatrix},$$
 where ε is a parameter controlling the importance of normal for positions. ε could be defined by the user or could be determined by applying an optimization procedure. They could also be fixed of adaptive.

- b. Two mappings from reference frame RF to current frame CF and from current frame CF to reference frame RF are computed as follows:
- i. Every point Q of reference frame RF is mapped to the point P(Q) of current frame CF that has the minimum distance to Q in the 6D space defined in the previous step.
 - ii. Every point P of current frame CF is mapped to the point Q(P) of reference frame RF that has the minimum distance to P in the 6D space defined in the previous step. Let $\rho(Q)$ be the set of points of current frame CF that are mapped to the same point Q.

c. At each iteration

- i. The positions of the points of reference frame RF are updated as follows:

$\alpha'(Q) = w \cdot \alpha(P(Q)) + \frac{(1-w)}{|\rho(Q)|} \sum_{P \in \rho(Q)} \alpha(P)$, where $|\rho(Q)|$ is the number of elements of $\rho(Q)$. The parameter w could be defined by the user or could be determined by applying an optimization procedure. It could also be fixed or adaptive.

- ii. The previous updated step results usually in an irregular repartition of the points. In order to overcome such limitations, a Laplacian-based smoothing procedure is applied. The idea is to update the positions of the points such that they stay as close as possible to $\{\alpha'(Q)\}$, while favoring a repartition as close as possible to the original point repartition in reference frame RF. More precisely, the following sparse linear system may be solved:

$\{\alpha^*(Q)\} = \underset{\{\alpha'(Q)\}}{\operatorname{argmin}} \left\{ \sum_{Q \in RF} \|\alpha''(Q) - \alpha'(Q)\|^2 + \gamma \sum_{Q \in RF} \left\| \alpha''(Q) - \frac{1}{R} \sum_{Q' \in N(Q)} \alpha''(Q') - \alpha(Q) - \frac{1}{R} \sum_{Q' \in N(Q)} \alpha(Q') \right\|^2 \right\}$, where $N(Q)$ is the set of the R nearest neighbors of Q in reference frame RF.

- iii. The mappings between the updated RF' point cloud and current frame CF are then updated as follows

1. Every point Q of RF' is mapped to the point P(Q) of current frame CF that has the minimum distance to Q in the 3D space of positions.
2. Every point P of current frame CF is mapped to the point Q(P) of reference frame RF that has the minimum distance to P in the 3D space of positions. Let $\rho(Q)$ be the set of points of current frame CF that are mapped to the same point Q.

- d. This process is iterated until a pre-defined number of iterations is reached or there is no further change.
- e. At this stage, the color and attribute information is transferred from current frame CF to RF' by exploiting the following formula

$$A(Q) = w(A).A(P(Q)) + \frac{(1-w(A))}{|\rho(Q)|} \sum_{P \in \rho(Q)} A(P),$$

where A stands for the texture or attribute to be transferred, $|\rho(Q)|$ is the number of elements of $\rho(Q)$. The parameter $w(A)$ could be defined by the user or could be determined by applying an optimization procedure. It could also be fixed or adaptive.

3D Motion Compensation

[00165] In some embodiments, the positions, attributes and texture information may be temporally predicted by taking the difference between the value at current resampled frame minus a corresponding value, e.g. motion compensated value, from the reference frame. These values may be fed to the image generation stage to be stored as images. For example, such techniques may be performed by 3D motion compensation and delta vector prediction module 254.

Smoothing Filter

[00166] In some embodiments, a smoothing filter of a decoder, such as smoothing filter 244 or smoothing filter 276 of decoder 230 or decoder 280, may perform smoothing as described below.

[00167] In some embodiments, a reconstructed point cloud may exhibit discontinuities at the patch boundaries, especially at very low bitrates. In order to alleviate such a problem, a smoothing filter may be applied to the reconstructed point cloud. Applying the smoothing filter may comprise:

- a. By exploiting the occupancy map, both the encoder and the decoder may be able to detect boundary points, which are defined as being points belonging to B0xB0 blocks encoded during the last iteration of the hierarchical occupancy map compression procedure described in previous sections above.

- b. The boundary points may have their positions/attribute/texture updated. More precisely, respective boundary points may be assigned a smoothed position based on its R nearest neighbors in the point cloud. The smoothed position may be the centroid/median of the nearest neighbors. Another option may comprise fitting a plane or any smooth surface the nearest neighbor and assigning as a smoothed position the projection of the point on that surface. The number of parameters and/or the smoothing strategy may be chosen by a user or determined by applying an optimization strategy. They may be fixed for all the points or chosen adaptively. These parameters may be signaled in the bit stream.
- c. In order to reduce the computational complexity of the smoothing stage, a subsampled version of the reconstructed point cloud may be considered when looking for the nearest neighbors. Such subsampled version could be efficiently derived by considering a subsampled version of the geometry image and the occupancy map.

Closed-Loop Color Conversion

[00168] In some embodiments, an encoder and/or decoder for a point cloud may further include a color conversion module to convert color attributes of a point cloud from a first color space to a second color space. In some embodiments, color attribute information for a point cloud may be more efficiently compressed when converted to a second color space. For example, FIGs. 4A and 4B illustrates encoders 400 and 450 which are similar encoders as illustrated in FIGs. 2A and 2C, but that further include color conversion modules 402 and 404, respectively. While not illustrated, decoders such as the decoders illustrated in FIGs. 2B and 2D, may further include color conversion modules to convert color attributes of a decompressed point cloud back into an original color space, in some embodiments.

[00169] FIG. 4C illustrates components of a closed-loop color conversion module, according to some embodiments. The closed-loop color conversion module 410 illustrated in FIG. 4C may be a similar closed-loop color conversion module as closed-loop color conversion modules 402 and 404 illustrated in FIGs. 4A and 4B.

[00170] In some embodiments, a closed-loop color conversion module, such as closed-loop color conversion module 410, receives a compressed point cloud from a video encoder, such as video compression module 218 illustrated in FIG. 4A or video compression module 264

illustrated in FIG. 4B. Additionally, a closed-loop color conversion module, such as closed-loop color conversion module 410, may receive attribute information about an original non-compressed point cloud, such as color values of points of the point cloud prior to being down-sampled, up-sampled, color converted, etc. Thus, a closed-loop color conversion module may receive a compressed version of a point cloud such as a decoder would receive and also a reference version of the point cloud before any distortion has been introduced into the point cloud due to sampling, compression, or color conversion.

[00171] In some embodiments, a closed-loop color conversion module, such as closed-loop color conversion module 410, may include a video decompression module, such as video decompression module 270, and a geometry reconstruction module, such as geometry reconstruction module 412. A video decompression module may decompress one or more video encoded image frames to result in decompressed image frames each comprising one or more patch images packed into the image frame. A geometry reconstruction module, such as geometry reconstruction module 412, may then generate a reconstructed point cloud geometry. A re-coloring module, such as re-coloring module 414, may then determine colors for points in the point cloud based on the determined reconstructed geometry. For example, in some embodiments, a nearest neighbor approach or other approach may be used to determine estimated color values for points of the point cloud based on sub-sampled color information, wherein a color value is not explicitly encoded for each point of the point cloud. Because there may be losses during the patching process, compression process, decompression process, and geometry reconstruction process, the geometry of the points in the reconstructed point cloud may not be identical to the geometry in the original point cloud. Due to this discrepancy, color compression techniques that rely on geometrical relationships between points to encode color values may result in colors that are slightly different when decoded and decompressed than the original colors. For example, if a color is to be determined based on color values of the nearest neighboring points, a change in geometry may cause a different nearest neighbor to be selected to determine the color value for the point at the decoder than was selected to encode a residual value at the encoder. Thus distortion may be added to the decoded decompressed point cloud.

[00172] If a color space conversion module does not account for this distortion that takes place when converting a point cloud into patches packed in an image frame and that takes place when encoding the image frames, the color space conversion module may select less than

optimum color conversion parameters, such as luma and chroma values. For example, optimum color conversion parameters that cause a packed image frame in a first color space to closely match the packed image frame converted into a second color space may be different than optimum color conversion parameters when upstream and downstream distortions are accounted for.

[00173] In order to account for such distortions, a texture/attribute image color space conversion and re-sampling module, such as module 416, may take into account a difference between the “re-created” color values from re-coloring module 416 and the original color values from the original non-compressed reference point cloud when determining color conversion parameters for converting an image frame from a first color space, such as R’G’B’ 4:4:4 to YCbCr 4:2:0, for example. Thus, the color-converted and re-sampled texture/attribute images provided to video encoder 218 and 264, as shown in FIG. 4C may take into account distortion introduced at any stage of compression and decompression of a point cloud, and may utilize optimum color conversion parameters taking into account such distortion.

[00174] Such methods may result in considerably reduced distortion when reconstructing the point cloud representation, while maintaining the high compressibility characteristics of the 4:2:0 signal.

[00175] In some embodiments, conversion from 4:4:4 R’G’B’ to a 4:2:0 YCbCr representation is performed using a 3x3 matrix conversion of the form:

$$\begin{bmatrix} Y' \\ Cb \\ Cr \end{bmatrix} = \begin{bmatrix} a_{YR} & a_{YG} & a_{YB} \\ a_{CbR} & a_{CbG} & a_{CbB} \\ a_{CrR} & a_{CrG} & a_{CrB} \end{bmatrix} \begin{bmatrix} R' \\ G' \\ B' \end{bmatrix}$$

[00176] In the above matrix, Y’ is the luma component and Cb and Cr are the chroma components. The values of R’, G’, and B’ correspond to the red, green, and blue components respectively, after the application of a transfer function that is used to exploit the psycho-visual characteristics of the signal. The coefficients a_{YR} through a_{CrB} are selected according to the relationship of the red, green, and blue components to the CIE 1931 XYZ color space. Furthermore, the Cb and Cr components are also related to Y’ in the following manner:

$$Cb = \frac{B' - Y'}{\alpha} \text{ with } \alpha = 2 * (1 - a_{YB})$$

$$Cr = \frac{R'-Y'}{\beta} \text{ with } \beta = 2 * (1 - a_{YR})$$

with also the following relationships:

$$a_{CbR} = -\frac{a_{YR}}{2*(1-a_{YB})}$$

$$a_{CbR} = -\frac{a_{YG}}{2*(1-a_{YB})}$$

$$a_{CbB} = 0.5$$

$$a_{CrR} = 0.5$$

$$a_{CrR} = -\frac{a_{YG}}{2*(1-a_{YR})}$$

$$a_{CrB} = -\frac{a_{YB}}{2*(1-a_{YR})}$$

[00177] The process described above is followed by a 2x down-sampling horizontally and vertically of the chroma components, resulting in chroma components that are 4 times smaller, in terms of overall number of samples, 2x smaller horizontally and 2x smaller vertically, compared to those of luma. Such a process can help not only with compression but also with bandwidth and processing complexity of the YCbCr 4:2:0 signals.

[00178] In using such an approach quantization for the color components, as well as the down sampling and up sampling processes for the chroma components, may introduce distortion that could impact the quality of the reconstructed signals especially in the R'G'B' but also in the XYZ (CIE 1931 domains). However, a closed loop conversion process, where the chroma and luma values are generated while taking into account such distortions, may considerably improve quality.

[00179] In a luma adjustment process, for example, the chroma components may be converted using the above formulations, additionally a down sampling and up sampling may be performed given certain reference filtering mechanisms. Afterwards, using the reconstructed chroma samples, an appropriate luma value may be computed that would result in minimal distortion for the luminance Y component in the CIE 1931 XYZ space. Such luma value may be derived through a search process instead of a direct computation method as provided above. Refinements and simplifications of this method may include interpolative techniques to derive the luma value.

[00180] Projected point cloud images can also benefit from similar strategies for 4:2:0 conversion. For example, closed loop color conversion, including luma adjustment methods

may be utilized in this context. That is, instead of converting point cloud data by directly using the 3x3 matrix above and averaging all neighboring chroma values to generate the 4:2:0 chroma representation for the projected image, one may first project point cloud data/patches using the R'G'B' representation on a 4:4:4 grid. For this new image one may then convert to the YCbCr 4:2:0 representation while using a closed loop optimization such as the luma adjustment method. Assuming that the transfer characteristics function is known, e.g. BT.709, ST 2084 (PQ), or some other transfer function as well as the color primaries of the signal, e.g. BT.709 or BT.2020, an estimate of the luminance component Y may be computed before the final conversion. Then the Cb and Cr components may be computed, down sampled and up sampled using more sophisticated filters. This may then be followed with the computation of the Y' value that would result in a luminance value Yrecon that would be as close as possible to Y. If distortion in the RGB domain is of higher distortion, a Y' value that minimizes the distortion for R', G', and B' jointly, could be considered instead.

[00181] For point cloud data, since geometry may also be altered due to lossy compression, texture distortion may also be impacted. In particular, overall texture distortion may be computed by first determining for each point in the original and reconstructed point clouds their closest point in the reconstructed and original point clouds respectively. Then the RGB distortion may be computed for those matched points and accumulated across the entire point cloud image. This means that if the geometry was altered due to lossy compression, the texture distortion would also be impacted. Given that the texture may have been distorted, it may be desirable to consider geometry during closed loop conversion of chroma.

[00182] In some embodiments, the geometry is modified so that the relative sampling density in a given region of the point cloud is adjusted to be similar to other regions of the point cloud. Here the relative sampling density is defined as density of original points relative to the uniform 2D sampling grid.

[00183] Because the relative sampling density can vary within a given patch, this information can be used to guide the patch decomposition process as described above in regard to occupancy maps and auxiliary information, where patch approximation is used to determine local geometry. Furthermore, this information can be used to guide encoding parameters to achieve more uniform quality after compression. If a local region has higher relative sampling

density, the encoder may code that region better through a variety of means. The variety of means may include: variable block size decision, Quantization Parameters (QPs), quantization rounding, de-blocking, shape adaptive offset (SAO) filtering, etc.

[00184] In some embodiments, the geometry information is first compressed according to a target bitrate or quality, and then it is reconstructed before generating the texture projected image. Then, given the reconstructed geometry, the closest point in the reconstructed point cloud is determined that corresponds to each point in the original point cloud. The process may be repeated for all points in the reconstructed point cloud by determining their matched points in the original point cloud. It is possible that some points in the reconstructed point cloud may match multiple points in the original point cloud, which would have implications in the distortion computation. This information may be used in the closed loop/luma adjustment method so as to ensure a minimized texture distortion for the entire point cloud. That is, the distortion impact to the entire point cloud of a sample P_r at position (x,y,z) in the reconstructed point cloud can be computed (assuming the use of MSE on YCbCr data for the computation):

$$D(P_r) = D_{\text{original}}(P_r) + D_{\text{reconstructed}}(P_r)$$

$$D(P_r) = \text{Sum_matching}(((Y_{pr} - Y_{or(i)})^2 + (Cb_{pr} - Cb_{or(i)})^2 + (Cr_{pr} - Cr_{or(i)})^2) + \text{sqrt}((Y_{pr} - Y_{or})^2 + (Cb_{pr} - Cb_{or})^2 + (Cr_{pr} - Cr_{or})^2))$$

[00185] In the above equation, Y_{pr} , Cb_{pr} , and Cr_{pr} are the luma and chroma information of point P_r , $Y_{or(i)}$, $Cb_{or(i)}$, and $Cr_{or(i)}$ correspond to the luma and chroma information of all the points that were found to match the geometry location of point P_r from the original image, and Y_{or} , Cb_{or} , and Cr_{or} is the point that matches the location of point P_r in the original as seen from the reconstructed image.

[00186] If the distortion computation in the context of closed loop conversion/luma adjustment utilizes $D(P_r)$, then better performance may be achieved since it not only optimizes projected distortion, but also point cloud distortion. Such distortion may not only consider luma and chroma values, but may instead or additionally consider other color domain components such as R, G, or B, luminance Y, CIE 1931 x and y, CIE 1976 u' and v' , YCoCg, and the ICtCp color space amongst others.

[00187] If geometry is recompressed a different optimal distortion point may be possible. In that case, it might be appropriate to redo the conversion process once again.

[00188] In some embodiments, texture distortion, as measured as described below, can be minimized as follows:

- Let $(Q(j))_{j \in \{1, \dots, N\}}$ and $(P_{rec}(i))_{i \in \{1, \dots, N_{rec}\}}$ be the original and the reconstructed geometries, respectively.
- Let N and N_{rec} be the number of points in the original and the reconstructed point clouds, respectively.
- For each point $P_{rec}(i)$ in the reconstructed point cloud, let $Q^*(i)$ be its nearest neighbor in the original point cloud and $R(Q^*(i))$, $G(Q^*(i))$, and $B(Q^*(i))$ the RGB values associated with $Q^*(i)$.
- For each point $P_{rec}(i)$ in the reconstructed point cloud, let $\mathbb{Q}^+(i) = (Q^+(i, h))_{h \in \{1, \dots, H(i)\}}$ be the set of point in the original point cloud that share $P_{rec}(i)$ as their nearest neighbor in the reconstructed point cloud. Note that $\mathbb{Q}^+(i)$ could be empty or could have one or multiple elements.
- If $\mathbb{Q}^+(i)$ is empty, then the RGB values $R(Q^*(i))$, $G(Q^*(i))$, and $B(Q^*(i))$ are associated with the point $P_{rec}(i)$.
- If $\mathbb{Q}^+(i)$ is not empty, then proceed as follows:
 - Virtual RGB values, denoted $R(\mathbb{Q}^+(i))$, $G(\mathbb{Q}^+(i))$, and $B(\mathbb{Q}^+(i))$, are computed as follows:
 - $R(\mathbb{Q}^+(i)) = \frac{1}{H(i)} \sum_{h=1}^{H(i)} R(Q^+(i, h))$
 - $G(\mathbb{Q}^+(i)) = \frac{1}{H(i)} \sum_{h=1}^{H(i)} G(Q^+(i, h))$
 - $B(\mathbb{Q}^+(i)) = \frac{1}{H(i)} \sum_{h=1}^{H(i)} B(Q^+(i, h))$
 - Note that $R(\mathbb{Q}^+(i))$, $G(\mathbb{Q}^+(i))$, and $B(\mathbb{Q}^+(i))$ correspond to the average RGB values of the points of $\mathbb{Q}^+(i)$.
 - The final RGB values $R(P_{rec}(i))$, $G(P_{rec}(i))$, and $B(P_{rec}(i))$ are obtained by applying the following linear interpolation:
 - $R(P_{rec}(i)) = w R(\mathbb{Q}^+(i)) + (1 - w) R(Q^*(i))$
 - $G(P_{rec}(i)) = w G(\mathbb{Q}^+(i)) + (1 - w) G(Q^*(i))$
 - $B(P_{rec}(i)) = w B(\mathbb{Q}^+(i)) + (1 - w) B(Q^*(i))$

- The interpolation parameter w is chosen such that the following cost function $C(i)$ is minimized

$$C(i) = \max \left\{ \frac{1}{N} \sum_{h=1}^{H(i)} \left\{ (R(P_{rec}(i)) - R(Q^+(i, h)))^2 + (G(P_{rec}(i)) - G(Q^+(i, h)))^2 + (B(P_{rec}(i)) - B(Q^+(i, h)))^2 \right\}, \frac{1}{N_{rec}} \left\{ (R(P_{rec}(i)) - R(Q^*(i)))^2 + (G(P_{rec}(i)) - G(Q^*(i)))^2 + (B(P_{rec}(i)) - B(Q^*(i)))^2 \right\} \right\}$$

- Note that by minimizing the cost $C(i)$, the distortion measure as described below is minimized.
- Different search strategies may be used to find the parameter w
 - Use the closed form solution described below.
 - No search: use $w = 0.5$.
 - Full search: choose a discrete set of values $(w_i)_{i=1...W}$ in the interval $[0,1]$ and evaluate $C(i)$ for these values in order to find the w^* , which minimizes $C(i)$.
 - Gradient descent search: start with $w = 0.5$. Evaluate $E1(i)$, $E2(i)$ and $C(i)$. Store $C(i)$ and w as the lowest cost and its associated interpolation parameter w . If $E1(i) > E2(i)$, update w based on the gradient of $E1(i)$, else use the gradient of $E2(i)$. Re-evaluate $E1(i)$, $E2(i)$, and $C(i)$ at the new value of w . Compare the new cost $C(i)$ to the lowest cost found so far. If new cost is higher than the lowest cost stop, else update the lowest cost and the associated value of w , and continue the gradient descent, where $R(P_{rec}(i))$, $G(P_{rec}(i))$, and $B(P_{rec}(i))$ are the three unknowns to be determined.

[00189] In some embodiments, the above process could be performed with other color spaces and not necessarily the RGB color space. For example, the CIE 1931 XYZ or xyY, CIE

1976 Yu'v', YCbCr, IPT, ICtCp, La*b*, or some other color model could be used instead. Furthermore, different weighting of the distortion of each component could be considered. Weighting based on illumination could also be considered, e.g. weighting distortion in dark areas more than distortion in bright areas. Other types of distortion, that include neighborhood information, could also be considered. That is, visibility of errors in a more sparse area is likely to be higher than in a more dense region, depending on the intensity of the current and neighboring samples. Such information could be considered in how the optimization is performed.

[00190] Down sampling and up sampling of chroma information may also consider geometry information, if available. That is, instead of down sampling and up sampling chroma information without consideration to geometry, the shape and characteristics of the point cloud around the neighborhood of the projected sample may be considered, and appropriately consider or exclude neighboring samples during these processes. In particular, neighboring samples for down sampling or interpolating may be considered that have a normal that is as similar as possible to the normal of the current sample. Weighting during filtering according to the normal difference as well as distance to the point may also be considered. This may help improve the performance of the down sampling and up sampling processes.

[00191] It should be noted that for some systems, up sampling of the Cb/Cr information may have to go through existing architectures, e.g. an existing color format converter, and it might not be possible to perform such guided up sampling. In those cases, only considerations for down sampling may be possible.

[00192] In some embodiments, it may be possible to indicate in the bit stream syntax the preferred method for up sampling the chroma information. A decoder (included in an encoder), in such a case, may try a variety of up sampling filters or methods, find the best performing one and indicate that in the bit stream syntax. On the decoder side, the decoder may know which up sampling method would perform best for reconstructing the full resolution YCbCr and consequently RGB data. Such method could be mandatory, but could also be optional in some architectures.

[00193] Clipping as well as other considerations for color conversion, may also apply to point cloud data and may be considered to further improve the performance of the point cloud compression system. Such methods may also apply to other color representations and not necessarily YCbCr data, such as the YCoCg and ICtCp representation. For such representations different optimization may be required due to the nature of the color transform.

Example Objective Evaluation Method

[00194] A point cloud consists of a set of points represented by (x,y,z) and various attributes of which color components (y,u,v) are of importance. First, define the point v . It has as a mandatory position in a 3D space (x,y,z) and an optional color attribute c that has components r,g,b or y,u,v and optional other attributes possibly representing normal or texture mappings.

point $v = (((x, y, z), [c], [a_0 \dots a_A]): x, y, z \in \mathbf{R}, [c \in (r, g, b) | r, g, b \in \mathbf{N}], [a_i \in [0,1]])$ (def. 1)

[00195] The point cloud is then a set of K points without a strict ordering:

Original Point Cloud $V_{or} = \{(v_i): i = 0 \dots K - 1\}$ (def. 2)

[00196] The point cloud comprises a set of (x,y,z) coordinates and attributes that can be attached to the points. The original point cloud V_{or} (420) will act as the reference for determining the quality of a second degraded point cloud V_{deg} (424). V_{deg} consists of N points, where N does not necessarily $= K$. V_{deg} is a version of the point cloud with a lower quality possibly resulting from lossy encoding and decoding of V_{or} (e.g. operation 422). This can result in a different point count N .

Degraded Point Cloud $V_{deg} = \{(v_i): i = 0 \dots N - 1\}$ (def. 3)

[00197] The quality metric $Q_{\text{(point cloud)}}$ is computed from V_{or} and V_{deg} and used for assessment as shown in FIG. 4D for full reference quality metric 426.

[00198] Table 3, below, outlines the metrics used for the assessment of the quality of a point cloud, in some embodiments. The geometric distortion metrics are similar as ones used for meshes based on hausdorff (L_{inf}) and root mean square (L_2), instead of distance to surface.

This approach takes the distance to the closest/most nearby point in the point cloud (see definitions 4, 5, 6, and 7) into account. Peak signal to noise ratio (PSNR) is defined as the peak signal of the geometry over the symmetric Root Mean Square (RMS/rms) distortion (def 8.). For colors, a similar metric is defined; the color of the original cloud is compared to the most nearby color in the degraded cloud and peak signal to noise ratio (PSNR) is computed per YUV/YCbCr component in the YUV color space (def. 10). An advantage of this metric is that it corresponds to peak signal to noise ratio (PSNR) in Video Coding. The quality metric is supported in the 3DG PCC software.

Table 3: Assessment criteria for assessment of the point cloud quality of Vdeg, Q_{point_cloud}

d_symmetric_rms	Symmetric rms distance between the point clouds	(def. 5.)
d_symmetric_hausdorff	Symmetric hausdorff distance between the clouds	(def. 7.)
psnr_geom	Peak signal to noise ratio geometry (vertex positions)	(def. 8.)
psnr_y	Peak signal to noise ratio geometry (colors Y)	(def. 10)
psnr_u	Peak signal to noise ratio geometry (colors U)	(as def. 10 rep. y for u)
psnr_v	Peak signal to noise ratio geometry (colors V)	(as def. 10 rep. y for v)

$$d_{rms}(V_{or}, V_{deg}) = \sqrt{\frac{1}{K} \sum_{v_o \in V_{or}} \|v_o - v_{d_nearest_neighbour}\|^2} \quad (\text{def.4})$$

$$d_{symmetric_rms}(V_{or}, V_{deg}) = \max(d_{rms}(V_{or}, V_{deg}), d_{rms}(V_{deg}, V_{or})) \quad (\text{def.5})$$

$$d_{hausdorff}(V_{or}, V_{deg}) = \max_{v_o \in V_{or}} (\|v_o - v_{d_nearest_neighbour}\|_2, v_d \text{ is the point in } V_{deg} \text{ closest to } v_o) \quad (L2) \quad (\text{def.6})$$

$$d_{symmetric_hausdorff}(V_{or}, V_{deg}) = \max(d_{hausdorff}(V_{or}, V_{deg}), d_{hausdorff}(V_{deg}, V_{or})) \quad (\text{def. 7})$$

$$BBwidth = \max((x_{max} - x_{min}), (y_{max} - y_{min}), (z_{max} - z_{min})) \quad (\text{def.8})$$

$$psnr_{geom} = 10 \log_{10}(|BBwidth|_2^2 / (d_{symmetric_rms}(V))^2) \quad (\text{def. 9})$$

$$d_y(V_{or}, V_{deg}) = \sqrt{\frac{1}{K} \sum_{v_o \in V_{or}} \left[y(v_o) - y(v_{d_nearest_neighbour}) \right]^2} \quad (\text{def.10})$$

$$psnr_y = 10 \log_{10}(|255|^2 / (d_y(V_{or}, V_{deg}))^2) \quad (\text{def. 11})$$

[00199] In some embodiments, additional metrics that define the performance of a codec are outlined below in Table 4.

Table 4: Additional Performance Metrics

Compressed size	Complete compressed mesh size
In point count	K, the number of vertices in Vor

Out point count	N, number of vertices in Vdeg
Bytes_geometry_layer	Number of bytes for encoding the vertex positions
Bytes_color_layer (opt)	Number of bytes for encoding the colour attributes
Bytes_att_layer (opt)	Number of bytes for encoding the other attributes
Encoder time (opt)	Encoder time in ms on commodity hardware (optional)
Decoder time (opt)	Decoder time in ms on commodity hardware (optional)

Example Closed Form Solution

[00200] For each point $P_{rec}(i)$ in the reconstructed point cloud, let $Q^*(i)$ be its nearest neighbor in the original point cloud. For each point $P_{rec}(i)$ in the reconstructed point cloud, let $(Q^+(i, h))_{h \in \{1, \dots, H(i)\}}$ be the set of point in the original point cloud that share $P_{rec}(i)$ as their nearest neighbor in the reconstructed point cloud. Let $\mathbb{Q}^+(i)$ be the centroid of $(Q^+(i, h))_{h \in \{1, \dots, H(i)\}}$.

If $H=0$, then $\mathcal{C}(P_{rec}(i)) = \mathcal{C}(Q^*(i))$

[00201] Denote as R-G-B vector $\mathcal{C}(P)$ associated with a given point P . In order to compute the color for a given $P_{rec}(i)$, we have the following formulation:

$$\operatorname{argmin}_{\mathcal{C}(P_{rec}(i))} \max \left\{ \frac{1}{N_{rec}} \|\mathcal{C}(P_{rec}(i)) - \mathcal{C}(Q^*(i))\|^2, \frac{1}{N} \sum_{h=1}^H \|\mathcal{C}(P_{rec}(i)) - \mathcal{C}(Q^+(i, h))\|^2 \right\}$$

$$\begin{aligned}
\text{Where } \max & \left\{ \frac{1}{N_{rec}} \|\mathbf{C}(P_{rec}(i)) - \mathbf{C}(Q^*(i))\|^2, \sum_{h=1}^H \|\mathbf{C}(P_{rec}(i)) - \mathbf{C}(Q^+(i)) + \mathbf{C}(Q^+(i)) - \mathbf{C}(Q^+(i, h))\|^2 \right\} \\
& = \max \left\{ \frac{1}{N_{rec}} \|\mathbf{C}(P_{rec}(i)) - \mathbf{C}(Q^*(i))\|^2, \frac{H}{N} \|\mathbf{C}(P_{rec}(i)) - \mathbf{C}(Q^+(i))\|^2 \right. \\
& \quad + \frac{1}{N} \sum_{h=1}^H \|\mathbf{C}(Q^+(i)) - \mathbf{C}(Q^+(i, h))\|^2 \\
& \quad \left. + \frac{2}{N} \sum_{h=1}^H \langle \mathbf{C}(P_{rec}(i)) - \mathbf{C}(Q^+(i)), \mathbf{C}(Q^+(i)) - \mathbf{C}(Q^+(i, h)) \rangle \right\} \\
& = \max \left\{ \frac{1}{N_{rec}} \|\mathbf{C}(P_{rec}(i)) - \mathbf{C}(Q^*(i))\|^2, \frac{H}{N} \|\mathbf{C}(P_{rec}(i)) - \mathbf{C}(Q^+(i))\|^2 \right. \\
& \quad \left. + \frac{1}{N} \sum_{h=1}^H \|\mathbf{C}(Q^+(i)) - \mathbf{C}(Q^+(i, h))\|^2 \right\}
\end{aligned}$$

[00202] Now denote $D^2 = \sum_{h=1}^H \|\mathbf{C}(Q^+(i)) - \mathbf{C}(Q^+(i, h))\|^2$, so that

$$\operatorname{argmin}_{\mathbf{C}(P_{rec}(i))} \max \left\{ \frac{1}{N_{rec}} \|\mathbf{C}(P_{rec}(i)) - \mathbf{C}(Q^*(i))\|^2, \frac{H}{N} \|\mathbf{C}(P_{rec}(i)) - \mathbf{C}(Q^+(i))\|^2 + \frac{D^2}{N} \right\}.$$

[00203] **Note: if $H=1$ then $D^2 = 0$**

[00204] Let $\mathbf{C}^0(P_{rec}(i))$ be a solution of the previous minimization problem. It can be shown that $\mathbf{C}^0(P_{rec}(i))$ could be expressed as:

$$\mathbf{C}^0(P_{rec}(i)) = w\mathbf{C}(Q^*(i)) + (1 - w)\mathbf{C}(Q^+(i))$$

[00205] Furthermore, $\mathbf{C}^0(P_{rec}(i))$ verifies:

$$\begin{aligned}
& \frac{1}{N_{rec}} \|w\mathbf{C}(Q^*(i)) + (1 - w)\mathbf{C}(Q^+(i)) - \mathbf{C}(Q^*(i))\|^2 \\
& = \frac{H}{N} \|w\mathbf{C}(Q^*(i)) + (1 - w)\mathbf{C}(Q^+(i)) - \mathbf{C}(Q^+(i))\|^2 + \frac{D^2}{N}
\end{aligned}$$

$$(1-w)^2 \|\mathbf{C}(\mathbb{Q}^+(i)) - \mathbf{C}(\mathbb{Q}^*(i))\|^2 = w^2 \frac{HN_{rec}}{N} \|\mathbf{C}(\mathbb{Q}^*(i)) - \mathbf{C}(\mathbb{Q}^+(i))\|^2 + \frac{D^2 N_{rec}}{N}$$

[00206] Let $\delta^2 = \|\mathbf{C}(\mathbb{Q}^*(i)) - \mathbf{C}(\mathbb{Q}^+(i))\|^2$ and $r = \frac{N_{rec}}{N}$

[00207] If $\delta^2 = 0$, then $\mathbf{C}(P_{rec}(i)) = \mathbf{C}(\mathbb{Q}^*(i)) = \mathbf{C}(\mathbb{Q}^+(i))$

$$\begin{aligned} (1-w)^2 \delta^2 &= w^2 r H \delta^2 + r D^2 \\ \delta^2 + w^2 \delta^2 - 2w \delta^2 &= w^2 r H \delta^2 + r D^2 \\ \delta^2 (1-rH) w^2 - 2\delta^2 w + (\delta^2 - r D^2) &= 0 \\ (rH-1)w^2 + 2w + (\alpha r - 1) &= 0 \end{aligned}$$

[00208] With $\alpha = \frac{D^2}{\delta^2}$

[00209] if $H=1$, then $w = \frac{1}{2}$

[00210] if $H>1$

$$\begin{aligned} \Delta &= 4 - 4(rH-1)(\alpha r - 1) \\ \Delta &= 4 - 4(rH-1)\alpha r + 4H - 4 \\ \Delta &= 4(H - (rH-1)\alpha r) \end{aligned}$$

[00211] If $\Delta = 0$

$$w = \frac{-1}{(rH-1)}$$

[00212] If $\Delta > 0$

$$\begin{aligned} w_1 &= \frac{-1 - \sqrt{(H - (rH-1)\alpha r)}}{(rH-1)} \\ w_2 &= \frac{-1 + \sqrt{(H - (rH-1)\alpha r)}}{(rH-1)} \end{aligned}$$

[00213] Where the cost $\mathbf{C}(i)$ is computed for both w_1 and w_2 and the value that leads to the minimum cost is retained as the final solution.

Compression/Decompression Using Multiple Resolutions

[00214] FIG. 5A illustrates components of an encoder that includes geometry, texture, and/or attribute downscaling, according to some embodiments. Any of the encoders described herein may further include a spatial down-scaler component 502, a texture down-scaler component 504, and/or an attribute down-scaler component 506 as shown for encoder 500 in FIG. 5A. For example, encoder 200 illustrated in FIG. 2A may further include downscaling components as described in FIG. 5A. In some embodiments, encoder 250 may further include downscaling components as described in FIG. 5A.

[00215] In some embodiments, an encoder that includes downscaling components, such as geometry down-scaler 502, texture down-scaler 504, and/or attribute down-scaler 506, may further include a geometry up-scaler, such as spatial up-scaler 508, and a smoothing filter, such as smoothing filter 510. In some embodiments, a reconstructed geometry image is generated from compressed patch images, compressed by video compression module 218. In some embodiments an encoder may further include a geometry reconstruction module (not shown) to generate the reconstructed geometry image. The reconstructed geometry image may be used to encode and/or improve encoding of an occupancy map that indicates patch locations for patches included in one or more frame images. Additionally, the reconstructed geometry image may be provided to a geometry up-scaler, such as spatial up-scaler 508. A geometry up-scaler may scale the reconstructed geometry image up to an original resolution or a higher resolution approximating the original resolution of the geometry image, wherein the original resolution is a resolution prior to downscaling being performed at spatial down-scaler 502. In some embodiments, the up-scaled reconstructed geometry image may be provided to a smoothing filter that generates a smoothed image of the reconstructed and up-scaled geometry image. The smoothing filter, such as smoothing filter 510, may approximate smoothing that would be applied via a smoothing filter of a decoder. This information may then be provided to the spatial image generation module 210, texture image generation module 212, and/or the attribute image generation module 214. These modules may adjust generation of spatial images, texture images, and/or other attribute images based on the reconstructed geometry images. For example, if a patch shape (e.g. geometry) is slightly distorted during the downscaling, encoding, decoding, and upscaling process, these changes may be taken into account when generating spatial images, texture images, and/or other attribute images to correct for the changes in patch shape (e.g. distortion). As an example, points of the point cloud represented

in the reconstructed geometry image may be slightly moved as compared to the locations of the points in the original geometry image. In such circumstances, a texture image generation module, as an example, may take into account these distortions and adjust texture values assigned to the points of a corresponding texture image patch accordingly.

[00216] FIG. 5B illustrates components of a decoder 520 that includes geometry, texture, and/or other attribute upscaling, according to some embodiments. For example, decoder 520 includes texture up-scaler 512, attribute up-scaler 514, and spatial up-scaler 516. Any of the decoders described herein may further include a texture up-scaler component 512, an attribute up-scaler component 514, and/or a spatial image up-scaler component 516 as shown for decoder 520 in FIG. 5B.

[00217] FIG. 5C illustrates rescaling from the perspective of an encoder, according to some embodiments. In some embodiments, a point cloud may be scaled in both the point cloud domain (e.g. 3D domain prior to patch projection) and in a video level domain (e.g. by scaling 2D image frames comprising patch information). For example FIG. 5C illustrates a point cloud 522 of a person. An encoder, such as encoder 500, performs 3D scaling of the point cloud 522 in the point cloud domain to generate a downscaled point cloud 524. Patches generated based on downscaled point cloud 524 are packed into image frame 526. Additionally, downscaling is performed on the image frame 526 at the video level to reduce a resolution of the image frame. The additional downscaling results in a downscaled image frame 528 that is then encoded into a bit stream 530.

[00218] FIG. 5D illustrates rescaling from the perspective of a decoder, according to some embodiments. In some embodiments, a decoder, such as decoder 520, may receive a bit stream, such as bit stream 530. The decoder may decode the video encoded bit stream to generate one or more video image frames, such as image frame 532. The decoder may further upscale the image frame 532 to generate an up-scaled image frame 534. The decoder may then use a patch reconstruction method, as described above, to generate a reconstructed point cloud 536 from the patch information included in the up-scaled image frame 534. The decoder may also perform up-scaling in the 3D point cloud domain to scale up the reconstructed point cloud 536 to a similar size as the original point cloud. This process may result in an up-scaled reconstructed point cloud 538.

[00219] FIG. 5E illustrates an example open loop rescaling, according to some embodiments. In an open loop rescaling of an image frame, a geometry plane, and a texture or other attribute plane may be independently scaled, where geometry distortion is not taken into account when scaling the texture or other attribute information. For example, geometry image frame 540 may indicate depths of points of a point cloud relative to a projection plane and texture or attribute image frame 544 may represent respective attributes of the points of the point cloud projected on to the projection plane. As shown in FIG. 5E, in an open loop rescaling process, the geometry information and the attribute information may be independently scaled to generate down-scaled geometry image frame 542 and down-scaled texture or attribute image frame 546, respectively. Also, as shown in FIG. 5E, the downscaled geometry image frame 542 may be video encoded/compressed to generate a geometry bit stream and the downscaled attribute image frame 546 may be video encoded/compressed to generate a texture or attribute bit stream, such as a texture/attribute bit stream. For example, spatial down-scaler 502 may downscale the geometry image frame 540 and the texture down-scaler 504 may independently downscale the texture image frame 544. In some embodiments, attribute down-scaler 506 may downscale an attribute image frame independently of spatial down-scaler 502 and texture down-scaler 504. Because different down-scalers are used to downscale different types of image frames (e.g. spatial information, texture, other attributes, etc.), different downscaling parameters may be applied to the different types of image frames to downscale geometry different than texture or attributes.

[00220] FIG. 5F illustrates an example closed loop rescaling, according to some embodiments. In some embodiments, a closed loop rescaling process may be used by an encoder such as encoder 500 to determine distortion or other changes to geometry that may occur as part of a downscaling, encoding, decoding, and/or upscaling process. In some embodiments, such distortion may be accounted for when downscaling other attributes, such as texture. An encoder, such as encoder 500, receives a point cloud 548. The encoder generates a geometry image frame for the point cloud 548, for example an image frame comprising patches representing relative depths of the points, such as an original geometry image frame 550. A point cloud compression geometry mapper, which may include a decomposition into patches module 506, a packing module 208, and a spatial image generation module 210, etc., generates the original geometry image frame 550. A geometry down-scaler, such as spatial

down-scaler 502 downscales the geometry image frame to generate downscaled geometry image frame 552. Note that “geometry plane” may be used to refer to geometry patch information, which may be included in an image frame only consisting of geometry patches as shown in FIG. 5F.

[00221] The downscaled geometry image frame 552 is compressed, for example by video compression module 218, and is converted into a geometry bit stream. In a closed loop process as shown in FIG. 5F, the geometry bit stream is decompressed at the encoder to generate a reconstructed geometry plane 554. The reconstructed geometry plane is then up-scaled, at the encoder, to generate an up-scaled reconstructed geometry plane 556.

[00222] The texture points of the original geometry image frame 550 are then mapped to the points of the reconstructed up-scaled geometry plane 556. Differences in locations of the points in the original geometry image frame and the re-constructed up-scaled geometry image frame are determined. Also, the points included in the geometry image frame 550 are adjusted to take into account distortion that may be introduced during the down-scaling, video compression, video-de-compression, and up-scaling processes. Additionally, this distortion may be taken into account by a point cloud compression (PCC) attribute/texture mapper to adjust texture values for points that are distorted during the down-scaling, video-compression, video-de-compression, and up-scaling process. Additionally, attribute values may also be adjusted to take into account geometry distortion. In this way, the texture and attribute points are mapped to the same points in the same locations as the decoder will encounter when reconstructing and up-scaling the geometry plane. Then, the encoder can take into account the distortion of the geometry plane that may occur due to downscaling, encoding, decoding, and upscaling.

[00223] The texture points mapped to the points of the reconstructed up-scaled geometry plane 556 may be used to generate an adjusted attribute/texture image frame 558. The adjusted attribute/texture image frame 558 may then be down-scaled to generate a down-scaled adjusted attribute/texture image frame 560. The down-scaled adjusted attribute/texture image frame 560 may then be video encoded and transmitted as an attribute/texture bit stream.

[00224] FIG. 5G illustrates an example closed loop rescaling with multiple attribute layers, according to some embodiments. In some embodiments, a similar process as described for FIG. 5F may be followed. However, multiple degrees of down-sampling may be performed for one or more attribute image frames being down-scaled. For example texture/attribute image plane 558 may not be downscaled at all (e.g. compression rate target 0), or may be downscaled according to a plurality of compression rate targets (e.g. compression rate targets 1-4) to generate down-scaled versions of the adjusted attribute/texture image frame 562. In such embodiments, a compression rate target may be dynamically adjusted, for example based on network conditions, processing capacity, etc.

[00225] FIG. 5H illustrates an example of video level spatio-temporal scaling, according to some embodiments. In some embodiments, a similar process as described in FIGs. 5C and 5D may be performed using video level spatio-temporal downscaling and upscaling. For example, a frame rate (e.g. a number of frames generated per unit time) may be adjusted up or down in order to improve compression efficiency. In such embodiments spatial temporal adjustments may be made instead of resolution scaling and/or in addition to resolution scaling. For example, point clouds 564 at sequential movements in time may be down-scaled in resolution and/or frame rate in the 3D domain to generate down-scaled point clouds 566. The point clouds 566 may be projected onto a patch plane and image frames 568 may be generated. Note image frames 568 may be geometry image frames or attribute image frames, or both. Additionally, video level spatio-temporal down-scaling may be applied to reduce a resolution of the image frames 568 and/or reduce a frame-rate of the image frames 568 to generate down-scaled image frames 570. Note FIG. Note FIG. 5H illustrates both frame-rate down-scaling (e.g. spatial temporal down-scaling) and resolution down-scaling. However, in some embodiments, spatio-temporal down-scaling may be performed without performing resolution down-scaling. The spatio-temporal and/or resolution down-scaled image frames 570 may then be video-encoded to generate bit stream 572.

[00226] FIG. 5H also illustrates an encoder receiving bit-stream 572. A video-decoding component of the decoder may video-decode the bit stream 572 to generate down-scaled image frames 574. The decoder may also perform video level-spatio temporal upscaling to interpolate between the down-scaled image frames to generate up-scaled image frame 576. For example, down-scaled image frames, as an example includes two image frames per unit of time, whereas

up-scaled image frames 576 includes a third image frame that has been generated in the 2D video domain by interpolating, and/or using other video-spatial intra frame compression techniques, such as motion vectors, etc. to generate the third image frame. The up-scaled image frames 576 may then be used to generate reconstructed point clouds 578. Note that three reconstructed point clouds have been generated based on up-scaled image frames 576. Optionally, the decoder may further upscale the reconstructed point clouds 578 either temporally or size-wise, or both, to generate up-scaled point clouds 580.

[00227] FIG. 5I illustrates an example closed loop rescaling with spatiotemporal scaling, according to some embodiments. For example, point clouds 582 may be used to generate original geometry image frames 584. The original geometry frames may further be down-scaled temporally and/or size-wise to generate down-scaled geometry image frames 586, which may have a different frame rate, such as f_g frames per second, as compared to f_o frames per second for original geometry image frames 584, where f_g is less than f_o . The down-scaled geometry image frames 586 may also have a smaller size than the original geometry image frames 584, such as height and width “g” as compared to height and width “o” of original geometry image frames 584. The down-scaled geometry image frames may further be video-encoded/compressed to generate geometry bit stream 596. In a closed loop compression procedure, the geometry bit-stream 596 may further be video-decompressed/decoded at the encoder to generate reconstructed down-scaled geometry images 588, which may have a similar frame rate and size as down-scaled geometry images 586. The encoder may further apply a similar spatio-temporal and/or size-based up-scaling algorithm as would be executed at a decoder to generate up-scaled reconstructed image frames 590, which may have a similar frame rate and size as original geometry image frames 584. In some embodiments, the encoder may further adjust the original geometry image frames and repeat the process to reduce distortion. In some embodiments, geometry bit-stream 596 communicated out of the encoder may be based on adjusted geometry image frames 584.

[00228] In some embodiments, a point cloud compression (PCC) texture/attribute mapper may further adjust attribute/texture values of attribute/texture image frames based on distortion introduced due to the down-scaling, video-encoding, video-decoding, and up-scaling of the geometry image frames. For example, adjusted attribute/texture image frames 592 may be generated. The adjusted attribute/texture image frames 592 may further be down-scaled at

generate down-scaled adjusted attribute/texture image frames 594, which may in turn be video-encoded to generate texture/attribute bit stream 598. While not illustrated for spatio-temporal down-scaling, a similar process as described in FIG. 5G may be performed, wherein a level of spatio-temporal down-scaling to be applied is determined based on an available bit rate to communicate the compressed point cloud.

[00229] As discussed above, methods of compressing point cloud video data may use conventional video codecs as well as auxiliary information that can help describe and reconstruct the point cloud information. The encoder and decoder diagrams of how that process is performed is shown in at least FIGS. 5A and 5B, respectively. Also, FIGs. 6A-6I further illustrate how relationships between geometry image frames and attribute/texture image frames may be used to improve compression efficiency and reconstruction accuracy. Similar techniques may be combined with up-scaling and down-scaling techniques as described herein in FIGs. 5A-5L.

[00230] As discussed above, the process of generating the image frames segments the point cloud into multiple 2D projected images/videos, each representing different types of information. This process is performed by segmenting the point cloud first into multiple patches that permit efficient projection of the entire 3D space data onto 2D planes. Each patch is associated with information such as geometry (also referred to herein as “spatial information”), texture, and other attributes if they are available. Such information is then copied at the co-located locations of the image frames on separate image sequences with each now containing only the geometry information, the texture information, and any other remaining attributes respectively. Auxiliary information that contains the patch information as well as an occupancy map that dictates which areas in these projected image sequences correspond to actual point cloud data and which are unoccupied, e.g. may contain no data or dummy data, are also provided. Compression is then applied on such information using different strategies. Auxiliary information, for example, is entropy coded, while occupancy maps may be down-converted and encoded using either conventional codecs or other methods such as run length compression. The separate projected image sequences on the other hand are compressed using conventional codecs. This results in a collection of multiple sub streams, e.g. a geometry sub stream, texture and attribute sub streams, as well as occupancy and auxiliary information sub streams.

[00231] As described above, all sub streams except the occupancy map are expected to be of the same resolution. Each point in the geometry sub stream essentially corresponds to a point in the final 3D reconstructed point cloud. In some embodiments, it is permitted for the signal to be encoded at a different resolution than the original representation. Also, in some embodiments, offsetting as well as rotating the point cloud is also possible. Seeing things from the encoder perspective, this is done by signaling in the stream header additional metadata that would identify the scaling, offset, and rotation that should be applied onto the original point cloud data prior to projecting it onto the target video planes. From the decoder perspective, these parameters are used after the reconstruction of a first 3D point cloud representation and utilized to generate the final 3D point cloud representation. In such a scheme, both geometry and attribute/texture video data are signaled at the same resolution as specified in the point cloud header. Per patch metadata including scaling factors and rotation parameters are also supported in such a scheme, with scaling though now applied on each projected patch independently.

[00232] However, in some embodiments, this scheme may be further extended by providing additional resolution scaling flexibility in the encoded streams. In particular, not only may the scaling be applied in 3D space or per patch, but in some embodiments scheme scaling may be applied on the entire projected point cloud video data. This may permit use of “conventional” 2D rescaling schemes and architectures, which are readily available in many architectures. Furthermore, unlike a scheme where geometry and attribute sub streams are encoded at the same resolution, this alternative scheme permits signaling of these sub streams at different resolutions. In some embodiments, this scheme could also be combined with the 3D scaling scheme described above, e.g. the specified 2D image frame scaling can follow in encoding order and precede in decoding order the 3D scaling process as described above. This can provide further flexibility in coding performance.

[00233] In particular, with the scheme described above the scaling factors, if any, that were applied to the point cloud signal in 3D space to change its resolution are known. Essentially the point cloud scene/object that is being represented would change from resolution $W_{3D} \times H_{3D} \times D_{3D}$ to $(s_x \times W_{3D}) \times (s_y \times H_{3D}) \times (s_z \times D_{3D})$. Then this rescaled object would be

projected using the patch approach specified above into a variety of sub videos, e.g. occupancy, geometry and attribute sub videos, each of a *nominal* resolution of $W_N \times H_N$. The nominal resolution may be currently specified in the group of frames header syntax of the MPEG PCC TMC2 draft (v1.2), using the syntax elements `frame_width` and `frame_height`. The scaling factors may be added into this syntax.

[00234] Group of frames header syntax

	Descriptor
<code>group_of_frames_header() {</code>	
<code> group_of_frames_size</code>	<code>u(8)</code>
<code> frame_width</code>	<code>u(16)</code>
<code> frame_height</code>	<code>u(16)</code>
<code> occupancy_resolution</code>	<code>u(8)</code>
<code> radius_to_smoothing</code>	<code>u(8)</code>
<code> neighbor_count_smoothing</code>	<code>u(8)</code>
<code> radius_to_boundary_detection</code>	<code>u(8)</code>
<code> threshold_smoothing</code>	<code>u(8)</code>
<code>}</code>	

[00235] With the proposed method one may also now rescale the geometry and attribute signal i further at a resolution of $W_G \times H_G$ and $W_{A(i)} \times H_{A(i)}$ respectively. There is no need of signaling the resolution of these videos in the point cloud compression PCC headers since that information already exists in the video bit streams themselves. Conventional algorithms can be used to rescale the videos from the nominal resolution of $W_N \times H_N$ to $W_G \times H_G$ or $W_{A(i)} \times H_{A(i)}$ and vice versa. These can be seen from the encoder perspective in FIG. 5C and from the decoder perspective in FIG. 5D.

[00236] FIG. 5E shows an open loop architecture for converting the geometry and attribute signals. In this architecture the geometry and attribute signals are created and converted independently. In some embodiments, the only dependency is that the geometry signal prior to downscaling and compression is used for generating the texture plane signal. However, in FIG. 5F, a closed loop architecture is considered. In this architecture, the geometry signal is scaled and coded first, then it is reconstructed and up converted to its original resolution. This new geometry signal is then used to generate the texture/attribute plane. Using this method, the texture (or attributes) generated more accurately correspond to the reconstructed geometry compared to the open loop architecture in the previous figure (FIG.

5E). It should be noted that the upscaling process of the geometry, if needed, should be matched across decoders to achieve the desired closed-loop performance. If the up-scalers do not match, there could be some difference in performance. The resolutions of the geometry and attribute signals also do not need to match in any of these systems. Conventional up-scalers, such as a separable filter based up-scaler, e.g. bicubic, lanczos, windowed cosine or sine, etc., or more complicated up-scalers, including bilateral up-scalers, edge adaptive, motion compensated, etc. could be used. Downscaling also could use similar methods, e.g. separable filters, edge preserving down-scalers, etc.

[00237] Such an approach could also be utilized by adaptive streaming solutions as well. In particular in adaptive streaming systems multiple streams may be generated at different resolutions and frame rates to better support the variability of a network. In this system apart from adjusting frame rates for the different layers, different resolutions can also be used between the texture and geometry to also augment such functionality. An example is shown in FIG. 5G where for a particular geometry signal multiple different bit streams are generated for the texture/attribute signal, each potentially having different frame rates and/or resolutions as well. An encoder may select to use the particular texture layer and then also select the appropriate corresponding sub-bit stream for the attribute/texture plane given the overall bandwidth characteristics of their network.

[00238] In a different aspect, downscaling and upscaling of the geometry plane and attribute/texture plane can be performed by considering the characteristics of the point cloud system and how the images are constructed. In particular, in the systems described above, images are constructed using patches. These patches are available at both the encoder and decoder. A conventional system likely will not be able to consider the patches, however a more advanced system could utilize the patches to improve these two processes. In particular, better performance could be achieved by processing/filtering when upscaling or downscaling only the samples within a patch. Samples outside the patch are likely padded samples that may have no direct relationship with the samples inside the patch and if filtered/processed together could contaminate the signal. By isolating such samples this contamination can be avoided and performance can be improved. Even if not able to extract the full patch location information in a system, it could still be possible to consider other related information such as the occupancy map information. Occupancy maps, even though less accurate if they were down sampled, can

still provide some improvement in performance. On the other hand, the interpolation process for the attribute signals may be augmented by also considering the characteristics, e.g. edges, in the geometry signal. In particular, edges may be extracted in the geometry signal, and they may be related to edges in the attribute signals and a guided interpolation based on that information may be performed. This is possible since edges in the two layers are highly related, especially at the boundaries of every patch. For example FIG. 6I further discusses an example guided interpolation technique.

[00239] In some embodiments, spatio-temporal rescaling may be applied as shown in FIGs. 5H and 5I. In some embodiments, on the encoder, frame dropping may be performed, while the decision to drop a frame may be based on how similar are the “neighboring” frames or the frame dropping could be done at a fixed rate (time stamps would still exist in the stream to inform the use of temporal relationships). In some embodiments “blending”/averaging of frames may be performed. That is, all frames may be scaled using different phase that is controlled “temporally”. For example, odd frames may be scaled vertically using phase 0, while even frames would be scaled vertically using phase 1. Those scaled images are called fields, which are then interleaved together to create interlace frames. This process could be used for projected point cloud data. Note that interleaving does not need to be restricted in vertical fashion, but could be done horizontally instead or as well.

[00240] For the temporal up conversion, frame repeats could be used, or more intelligent methods could be used that include motion adaptive and motion compensated strategies for the interpolation. Machine learning methods could also be used to assist with the interpolation.

[00241] In some embodiments, the temporal resolution may be only reduced in one of the planes (e.g. geometry or attribute/texture) while for the other all frames are retained (along with the occupancy and patch information). In such a case the “shape” and location of all patches in the reduced temporal resolution plane are known, but the exact value of its characteristics (depth for geometry, color for attribute/texture) is not known. However, that value may be computed by trying to locate each patch in their temporal adjacent neighbors. That can be done by searching using the shape information of the patch and/or the available values of the patch characteristics of the full resolution plane. That basically would involve a

search (e.g. a motion estimation based search). When a patch is located, the information from the characteristics to interpolate from its temporal neighbors can be copied/blended and used as a predictor.

[00242] FIG. 5J illustrates a process of encoding/compressing image frames of a point cloud using down-scaling, according to some embodiments.

[00243] At 501, an encoder determines for a point cloud a plurality of patches projected on 2D planes. For example, any of the patch projection procedures described herein may be used.

[00244] At 503, the encoder generates attribute (or texture) patch images and geometry patch images for the patches. For example, any of the patch image generation techniques described herein may be used.

[00245] At 505, the encoder packs the generated attribute/texture patch images and the generated geometry patch images into one or more image frames. Note that the packing of the patch images and the generating of the patch images may occur concurrently. Any of the patch image packing techniques described herein may be used.

[00246] At 507, the encoder down-scales at least one of the image frames video down-scaling process. For example, the down-scaling process may include resolution reduction and/or frame rate reduction. Also, the down-scaling process may be open-loop or closed loop. Also the down-scaling process may be adjusted based on available bit rate, or not. Any of the down-scaling techniques described in regard to FIGs. 5A-5L may be used.

[00247] At 509, the encoder video encodes one or more bit streams based on the down-scaled image frames. Any video encoding technique as described herein may be used.

[00248] FIG. 5K illustrates a process of determining to down-scaling image frames using open-loop or closed-loop down-scaling, according to some embodiments.

[00249] At 511, the encoder receives a point cloud to compress. At 513, the encoder determines whether to apply down-scaling, and if so, whether to utilize an open-loop down-

scaling process, as described herein, or a closed-loop down-scaling process, as described herein. For example, the encoder may determine whether to utilize an open-loop or closed-loop down-scaling process based on a complexity of the point cloud and an availability of processing capacity to perform the down-scaling. For example, a complicated point cloud with a larger number of patches may be down-scaled using an open-loop down-scaling process when processing capacity is limited, but may be down-scaled using a closed-loop down-scaling process when more processing capacity is available. For example, if the combination of complexity and available processing capacity are such that one or more thresholds are exceeded, the down-scaling may be performed at 515 via an open-loop process. Conversely, if the combination of complexity and available processing capacity are such that the one or more thresholds are not exceeded, the down-scaling may be performed at 517 via a closed-loop process.

[00250] FIG. 5L illustrates a process of decoding/decompressing image frames of a point cloud using up-scaling, according to some embodiments.

[00251] At 521, a decoder receives a bit stream comprising video encoded image frames of a point cloud. At least one of the video encoded image frames was video encoded from a down-scaled image frame, such as the down-scaled image frames discussed herein. The at least one down-scaled image(s) frame may have been down-scaled in size or frame-rate, or both.

[00252] At 523, the decoder video de-codes the bit stream to generate one or more image frames comprising the at least one down-scaled image frame(s).

[00253] At 525, the decoder determines which of the image frames have been down-scaled. For example any of the techniques described above may be used to identify down-scaled image frames.

[00254] At 527, the decoder up-scales the at least one down-scaled image frame(s). The down-scaled image frame(s) may be up-scaled in size, frame-rate, or both. In some embodiments, any of the up-scaling techniques described herein may be used.

[00255] At 529, the decoder generates a reconstructed version of the compressed point cloud based on the video decoded and/or up-scaled image frames. Any of the reconstruction procedures described herein may be used.

Pre Video Compression Pre-Processing and Post Video Decompression Filtering/Post-Processing

[00256] As discussed above, video point cloud data may be compressed using conventional video codecs. As discussed above, the process segments a point cloud frame into multiple 2D projected images/videos, each representing different types of information. This process is performed by segmenting the point cloud into multiple patches that permit one to efficiently project the 3D space data of the point cloud onto 2D planes. Each patch is associated with information such as geometry, texture, and/or other attributes. Such information is then copied at co-located locations on separate image frame sequences with each image frame containing the geometry information, the texture information, or any other remaining attributes, respectively as patch images packed into the image frame. Auxiliary information that contains the patch information as well as an occupancy map that dictates which areas in these projected image frame sequences correspond to actual point cloud data and which are unoccupied, e.g. may contain no or dummy data, are also provided. Compression is applied on such information using different strategies. Auxiliary information, for example, can be entropy coded, while occupancy maps may be down converted and encoded using either conventional video codecs or other methods such as run length compression. The separate projected image sequences on the other hand are compressed using conventional video codecs. This results in a collection of multiple sub streams, e.g. a geometry sub stream, texture and attribute sub streams, as well as occupancy and auxiliary information sub streams. All these streams are multiplexed together to generate the final point cloud bit stream as shown in FIGs. 2A. In some embodiments, these streams may be provided to an image frame pre-processing/filtering element of an encoder to make intelligent pre-processing decisions and/or to intelligently adjust parameters used for video encoding based on information included in these streams.

[00257] FIG. 6A illustrates components of an encoder that further includes pre-video compression texture processing and/or filtering and pre-video decompression geometry processing/filtering, according to some embodiments. Encoder 600 includes image frame pre-

processing/filtering element 602. In some embodiments, any of the encoders described herein, such as encoder 200, 250, 400, 450, or encoder 500 may further include a texture processing/filtering element, such as texture processing/filter element 602. In some embodiments, any of the decoders described herein, such as decoder 230 or decoder 280, may further include a geometry processing/filtering element, such as geometry/filtering element 604. In some embodiments, pre-processing of a packed image frame from image frame padding element 216 may be pre-processed via image frame pre-processing/filtering element 602 prior to being video encoded by video compression 218. In some embodiments, image frame pre-processing /filtering element 602 may receive occupancy map information, spatial information, for example from spatial image generation element 210, texture information, for example from texture image generation element 212, and attribute information, for example from attribute image generation element 214.

[00258] In some embodiments, an image frame pre-processing/filter element, such as image frame pre-processing/filter element 602, may determine relationship information indicating relationships between respective attribute patch images and/or depth patch images. Additionally, the relationship information may include relationships between the respective patches and an image frame, for example which portions of the image frame are occupied or unoccupied and where edges of the patches in the image frame are located.

[00259] In some embodiments, an encoder, such as encoder 600, may utilize a received or determined occupancy map to determine the relationship information. In some embodiments, an image frame pre-processing/filtering element, such as image frame pre-processing/filtering element 602, may cause one or more encoding parameters of a video encoding component, such as video compression 218, to be adjusted based on the determined relationship information. For example, the image frame pre-processing/filtering element may cause the video encoding component to allocate more encoding resources to encoding portions of the image frame that are occupied with patches and may cause the video encoding component to allocate fewer encoding resources to encoding portions of the image frame that are unoccupied. Also, in some embodiments, the relationship information may indicate a plurality of patches (e.g. attribute patch images and/or depth patch images) that correspond to a same set of points projected onto a same patch plane. In some embodiments, an image frame pre-processing/filtering element may cause a video encoding component to utilize complementary

encoding parameters when encoding patches corresponding to a same set of points in the point cloud.

[00260] In some embodiments, an image pre-processing/filtering element, such as image pre-processing/filtering element 602, may determine a pooled distortion for a set of points. For example, the image frame pre-processing/filtering element may determine an amount of distortion introduced due to video compression of a depth patch image, an amount of distortion introduced due to video compression of an attribute patch image (such as colors), and an impact of overall or pooled distortion on the reconstructed point cloud based on the interactions of the distortions introduced for the separate patches. For example, depth distortion may cause additional color distortion in a reconstructed point cloud. In some embodiments, the image frame pre-processing/filtering element may adjust one or more video encoding parameters of a video encoding component, such as video compression 218, in order to reduce the overall pooled distortion for the set of points.

[00261] In some embodiments, an image pre-processing/filtering element, such as image pre-processing/filtering element 602, may determine edges of patches based on the relationship information. The image pre-processing/filtering element may further adjust one or more pre-processing processes such as color down-sampling of the one or more images, for example as described above in regard to closed-loop color conversion, based on the boundaries of the patches according to their determined edges.

[00262] FIG. 6B illustrates components of a decoder that further includes post video decompression texture processing and/or filtering and post video decompression geometry processing/filtering, according to some embodiments. Decoder 610 includes texture processing/filtering element 612 and geometry processing/filter element 614. In some embodiments, any of the decoders described herein, such as decoder 230, 280, or 550 may further include a texture processing/filtering element, such as texture processing/filter element 612. In some embodiments, any of the decoders described herein, such as decoder 230, 280, or 550, may further include a geometry processing/filtering element, such as geometry/filtering element 614.

[00263] In some embodiments, relationship information for patch images in an image frame may be included in or derived from a bit stream for a compressed point cloud. For example, FIG. 6C illustrates a bit stream structure for a compressed point cloud, according to some embodiments. In some embodiments, the auxiliary information may include relationship information for patch images. Also, in some embodiments an occupancy map may include relationship information for patches of an image frame. For example, an occupancy map may indicate which portions of an image frame are occupied or unoccupied. Also, the auxiliary information may indicate which blocks of an image frame correspond to which patches. This information may be used to determine portions of an image frame that correspond to a same patch. Also depth information included in the geometry information (e.g. depth patch images) may be used to identify portions of image frames for points having a common depth in the point cloud. Additionally, attribute/texture information included in the texture video stream may be used to identify patches in the image frames with similar textures or attribute values. In some embodiments, an attribute texture processing/filtering element, such as attribute processing/filtering element 612, and a geometry processing/filtering element, such as geometry/filtering element 614, may utilize these data streams to determine or receive relationship information for patches included in one or more video encoded image frames, such as are included in the group of frames for the geometry video stream, and such as are included in the group of frames for the texture/attribute video stream. The attribute processing/filtering element and/or geometry processing/filtering element may further utilize these determined or received relationships to intelligently post-process geometry image frames in the geometry video stream or to post-process texture/attribute image frames in the texture video stream. Also, in some embodiments, geometry patches (e.g. depth patches) and texture or attribute patches may be packed into a same image frame. Thus, in some embodiments, a texture/attribute video stream and a geometry video stream may be combined into a common video stream comprising image frames with both geometry patches and attribute/texture patches.

[00264] One of the characteristics of this point cloud coding scheme is that the different projected image sequences can be not only compressed using “conventional” codecs but also processed with conventional processing algorithms reserved for 2D image/video data. That is, one could apply de-noising, scaling, enhancement, and/or other algorithms commonly used for processing 2D image data onto these image sequences. Such processing could have advantages,

especially in terms of complexity and reuse of existing hardware implementations, versus performing such processing in the 3D domain.

[00265] One example of such processing is the conversion of the data from an RGB 4:4:4 representation to a 4:2:0 YCbCr representation and vice versa. In that scenario, for down conversion, the RGB data would be, for example, first converted to a YCbCr 4:4:4 representation, and then the chroma planes could be filtered and downsampled to $\frac{1}{4}$ of their original resolution (half resolution horizontally and vertically). For the inverse process, the chroma planes would be upsampled to their original resolution, e.g. back to YCbCr 4:4:4, and then the signal would be converted back to RGB 4:4:4. A variety of down conversion and up conversion methods could be used, including the use of edge adaptive downsampling and upsampling, as well as techniques such as the luma adjustment method.

[00266] Although some conventional processing methods may operate “as is” on the point cloud projected image sequences, they do not fully consider the characteristics of such images and in particular the relationship that exists between different layers or the information about patches and occupancy. Consideration of such information could improve performance. For example, such methods may be improved by taking into account such characteristics and information, therefore improving performance and the final quality of the reconstructed 3D point cloud from the projected images.

[00267] In particular, conventional methods will most likely process the projected image sequences assuming that all samples inside these sequences are highly correlated and that adjoining samples likely correspond to the same or at least neighboring objects. Unfortunately, this may not be the case in such imagery. In fact, such image frames comprise samples that correspond to projected patches, as well as filler areas used to separate and distinguish these patches. Such filler areas may be left unfilled, e.g. with a default color value, or may have been filled using padding methods as described herein. Processing of individual samples, e.g. when using long filters for filtering, may result in contamination of information between different patches as well as the filler areas, which can impair quality.

[00268] Knowledge of the precise patch location and the filler areas can instead benefit performance substantially. In some embodiments, a processing engine (such as texture processing/filtering element 612 and/or geometry processing/filtering element 614) performs filtering/processing operations on such image data on a patch by patch basis. That is, a particular sample s is processed/filtered by accounting for samples that correspond to the same patch as s . Samples that may have been included in the processing using a conventional method, e.g. because of the consideration of a long filter, but which do not correspond to the same patch are excluded from the processing of s . This could be done, for example, by reducing the length of the processing filter until such samples are fully excluded, or by performing on the fly extrapolation of the data at the boundaries between patches, when processing, and using the extrapolated data in place of the available data outside a patch.

[00269] The same or similar principles could be applied when processing filler data, which can be seen as a patch on its own.

[00270] A particular system may consider the exact location and shape information for each individual patch, e.g. it may require that the patch information be fully decoded and therefore is fully available during processing. This can provide the most accurate processing and can avoid contamination across patches. In some embodiments, an approximation of the patch location and shape can be determined by looking only at the occupancy map information, which may have been coded using a conventional 2D video coding system. In this case, since occupancy information may have been subsampled, e.g. by 4 times horizontally and vertically (16 times overall), some of the samples at the boundaries of the patch may have been duplicated. This may have some implications in performance, however, processing complexity can be considerably lower since there is no need to decode the full patch information.

[00271] Point cloud data are associated with geometry information as well as other attributes, e.g. texture, color, reflectance information, etc. Improved performance may be achieved by considering the relationships and characteristics across different attributes. In particular, similarity or dissimilarity of the geometry sample values in the projected plane may be accounted for when processing the corresponding samples in an attribute plane. In particular,

neighboring projected samples that correspond to the same or similar depth in the geometry plane are expected to be highly correlated. However, neighboring samples that have very dissimilar depth information are less likely to be correlated. Therefore, when processing such samples, depth information could also be considered to determine how these samples should be considered.

[00272] In some embodiments, samples that are too far from a sample x in terms of depth distance, e.g. exceed a distance threshold T , may be excluded when processing sample x . Other samples may be weighted or prioritized in processing again based on their distance. Corresponding information from other attributes and how similar or dissimilar these attributes are could also be considered when processing the sample. Information, such as edges extracted from the geometry plane or from other attribute planes could also be considered when processing. In the particular example of chroma down sampling (e.g. 4:4:4 to 4:2:0), as discussed earlier, edge directed downsampling using the geometry as well as luma attribute information could be performed in the first case, while similarly for up sampling (e.g. 4:2:0 to 4:4:4) an edge directed upsampling process using geometry and luma attribute information could be performed. Such processing could again be patch/occupancy map based as described earlier, however such processing could also be performed on its own without such consideration. In another example, directed interpolation could be performed of the attribute planes from a resolution $H_o \times W_o$ to a new resolution $H_n \times W_n$, again using information from the geometry information and/or other attribute planes that may be available. For example, FIG. 6I illustrates an example application where an attribute plane is upscaled using its corresponding geometry information and the geometry extracted edges, according to some embodiments.

[00273] In some embodiments, other applications that utilize the proposed filter/processing techniques described above may include de-noising, de-banding, de-ringing, de-blocking, sharpening, edge enhancement, object extraction/segmentation, display mapping (e.g. for HDR applications), recoloring/tone mapping, among others. Such methods could also be utilized for quality evaluation, e.g. by pooling together and considering data (e.g. summing distortion values) in corresponding patches that also correspond to similar geometry information and other attributes when evaluating a particular distortion measurement.

Processing may be purely spatial, e.g. only projected images that correspond to the same time stamp may be considered for such processing, however temporal/spatio-temporal processing may also be permitted, e.g. using motion compensated or motion adaptive processing strategies.

[00274] FIG. 6D illustrates a process for generating video encoded image frames for patches of a point cloud taking into account relationship information between the patches packed into the image frames, according to some embodiments.

[00275] At 620, an encoder generates attribute (or texture) image patches for sets of points projected onto patch planes. At 622, the encoder generates depth (e.g. geometry) patch images for sets of points projected onto the patch planes. At 624, the encoder packs the generated patch images into one or more image frames. In some embodiments, various ones of the patch generation and image frame packing techniques described herein may be used to generate the attribute patch images, the depth patch images, and to pack the generated patch images into one or more image frames.

[00276] At 626, the encoder generates one or more occupancy maps for the one or more packed image frames. In some embodiments, various ones of the techniques described herein to generate an occupancy map may be used.

[00277] At 628, the encoder optionally performs one or more pre-processing processes on the packed image frames taking into account the relationships between the attribute patch images and the depth patch images packed into the one or more image frames.

[00278] At 630, the encoder (or a separate video encoding component) video encodes the one or more image frames, wherein one or more parameters of the video encoding is adjusted based on the determined relationships between the patch images. For example, one or more parameters may be adjusted based on a pooled distortion for patches corresponding to the same set of points. Also, a color conversion process may be adjusted based on patch boundaries, as a few examples. In some embodiments, various other video encoding parameters may be intelligently adjusted based on knowledge not typically available to a video encoder regarding

which portions of an image frame relate to patches, and which do not. For example, as explained above, default encoding algorithms for a video encoder may assume that pixels proximate to one another are highly correlated. However, in the case of packed image frames, points on either side of a patch image boundary may vary and not be correlated as would be expected in other video images. As explained above, in some embodiments, a video encoder may disregard padded portions of the image frame when selecting video encoding parameters. Also, other adjustments may be made in view of knowledge of the relationships between the patch images packed into the image frames.

[00279] FIG. 6E illustrates a process for generating video encoded image frames taking into account pooled distortion for a set of patches corresponding to a same set of points, according to some embodiments.

[00280] At 632, an encoder identifies attribute patch images and depth patch images corresponding to a same set of points projected on a same patch plane. For example, this information may be included in auxiliary information that is to be included in a compressed point cloud stream.

[00281] At 634, the encoder determines a pooled amount of distortion affecting the set of points based on distortion introduced via video encoding the attribute patch images and the depth patch images for the set of points. For example, the encoder may video encode and video decode one or more image frames to determine distortion introduced for the respective patches. Also, in some embodiments, a video encoding component may have known distortion levels associated with various settings and the encoder may be able to determine levels of distortion that will be introduced based on the selection of such settings. In some embodiments, distortion in one patch image may compound distortion in another patch image when reconstructing a representation of the point cloud. For example, depth distortion combined with attribute or texture distortion may compound upon each other, where points are both moved in a reconstructed point cloud and also have changed colors. In some embodiments, these effects may be greater than the sum of the individual distortions. For example, depth distortion may further highlight color distortion and vice-versa.

[00282] At 636, the encoder adjusts one or more video encoding parameters and/or one or more pre-processing parameters to reduce the overall amount of pooled distortion for the set of points.

[00283] FIG. 6F illustrates a process for generating video encoded image frames taking into account patch edges, according to some embodiments.

[00284] At 638, an encoder determines edges for attribute patch images or depth patch images packed into one or more image frames. For example, such information may be included in an occupancy map for the image frame, and/or in auxiliary information for the image frame.

[00285] At 640, the encoder provides the relationship information to a video encoding component that will video encode the image frame.

[00286] At 642, the video encoding component adjusts one or more video encoding parameters and/or an image pre-processing/filtering element adjusts one or more parameters based on the determined edges. For example, a pre-processing filter may be adjusted to avoid cross patch contamination or contamination between patch portions and pad portions of the image frame.

[00287] FIG. 6G illustrates a process for reconstructing a point cloud based on video encoded image frames comprising patches of the point cloud, wherein relationship information between the patches packed into the image frames is taken into account, according to some embodiments.

[00288] At 650, a decoder receives one or more image frames comprising attribute patch images and depth patch images packed into one or more image frames. For example, the one or more image frames may have been packed with patch images as described herein.

[00289] At 652, the decoder receives an occupancy map and/or auxiliary information for the one or more image frames. For example, the one or more image frames, occupancy map, and/or auxiliary information may be included in a group of frames and/or point cloud data stream as shown in FIG. 6C.

[00290] At 654, the decoder receives (e.g. via the occupancy map or auxiliary information) or determines (e.g. based on the occupancy map and/or auxiliary information) one or more relationships for the attribute patch images and/or depth patch images packed in the one or more image frames. In some embodiments, the one or more determined relationships may indicate portions of the image frame that are occupied and unoccupied. In some embodiments, the one or more determined relationships may indicate a depth patch image and one or more attribute or texture patch images that correspond to a same set of points projected on a same patch plane as the depth patch image. In some embodiments, the one or more determined relationships may indicate regions of a set of one or more attribute patch images and one or more depth patch images which correspond to a same depth of the point cloud. In some embodiments, the one or more determined relationships may indicate regions of a set of one or more attribute patch images which share similar attribute values. In some embodiments, the one or more determined relationships may indicate regions of a set of one or more attribute patch images and one or more depth patch images which correspond to patches comprising points of the point cloud with depth gradients that deviate from one another by less than a threshold amount. In some embodiments, other relationships may be determined based on the occupancy map and/or auxiliary information.

[00291] At 656, the decoder video decodes the one or more packed image frames. In some embodiments, the decoder adjusts decoding parameters based on the determined relationships.

[00292] At 658, the decoder performs one or more post-processing processes on the video decoded image frames before using the depth patch images and attribute or texture patch images to reconstruct a reconstructed representation of the point cloud. As explained above, it may be more efficient to perform post-processing on a 2-D representation via a video post-processing process than to perform post-processing in a 3-D space comprising points of a point cloud reconstructed from the patch images included in the 2-D image frames. The decoder may adjust one or more parameters of the post-processing based on the determined relationships. For example, a long filter may be adjusted to avoid cross-contamination across patch images, between patches and padding, or between patch images. In some embodiments, various post-processing processes may be adjusted, such as: denoising, debanding, deringing, deblocking, sharpening, object extraction or segmentation, display mapping, wherein a range of the one or

more image frames is mapped to a range to be used to display a reconstructed representation of the point cloud, a color space conversion of the one or more image frames, a filtering process of the one or more image frames, color or tone adjustment processes applied to the one or more image frames, etc.

[00293] At 660, the decoder generates a reconstructed representation of the compressed point cloud based on attribute information and depth information extracted from the patch images in the one or more image frames that have undergone the post-processing processes at 658.

[00294] FIG. 6H illustrates a process of upscaling a patch image included in an image frame taking into account edges of the patch image determined based on received or determined relationship information for the patches, according to some embodiments.

[00295] At 670, a decoder determines edges of an attribute patch image or a depth patch image in an image frame based on the determined relationships (e.g. determined from an occupancy map and/or auxiliary information). For example, FIG. 6I illustrates an edge extraction process being applied to a geometry plane 680 to determine edges 682 of patch images in the geometry image frame.

[00296] At 670, an attribute patch image or depth patch image is up-scaled. For example, any of the up-scaling and down-scaling processes described herein may take advantage of determined relationships as described for an encoder or decoder in regards to FIGs. 6A-6I. For example, FIG. 6I also illustrates an attribute patch image 684 being up-scaled.

[00297] At 674, edges of the up-scaled attribute or depth patch image are updated based on an interpolation between points of the extracted edges determined at 670. For example, FIG. 6I illustrates a directed interpolation step included in the processing of attribute plane 684 to result in up-scaled attribute plane 686.

Non-Normative/Out-of-Loop Smoothing

[00298] As previously discussed the concept of smoothing is an important aspect of video-based point cloud compression/decompression. Smoothing can be seen as an artifact filtering process that is applied to either the geometry or attribute information, that tries to reduce discontinuities of the signal so as to improve its objective and/or subjective quality. Such operations may be applied in the 3D domain, e.g. after the points have been re-projected from the 2D domain onto the 3D domain. As discussed above, in some embodiments, the geometry smoothing process may be performed on points that are associated with a patch boundary, and may essentially try to reduce discontinuities that may have occurred at those boundaries due to both compression and also occupancy quantization/resolution reduction, etc. The process may be controlled through parameters signaled in the bitstream (e.g. in a Supplemental Enhancement Information (SEI) message) that alter the neighborhood of points that are considered for the smoothing process as well as a threshold that helps determine the strength of the filtering that is applied to a particular point given its neighboring samples. Other smoothing processes could also be considered, e.g. smoothing that filters all samples regardless of those being on a patch edge boundary, filters that use different thresholds based on patch position, filtering that may utilize different weighting for a particular dimension (x, y, z) of a point and the relationship of that dimension with the patch, etc. A form of smoothing can also be applied to the attribute information so as to also reduce the discontinuities that may exist in the attributes as well. This can be seen as a similar process to processes like the deblocking and adaptive loop filtering techniques utilized by many image and video coding schemes.

[00299] Since the attribute information is closely tied to the geometry information and because the distortions that may have been introduced to the geometry due to its compression, an encoder may include a process that remaps the attribute information prior to encoding based on the reconstructed geometry information (i.e. after the geometry compression and decompression, and after its reconstruction from 2D to 3D domain) to compensate for the distortions. This process may be referred to as an attribute transfer process and may attempt to interpolate or extrapolate the attribute information from its original (prior to compression) geometry positions, to the reconstructed geometry positions that resulted after compression and decompression. This can minimize the attribute distortion since attributes and their values are now better associated with the reconstructed geometry. This process may be referred to herein

as the "attribute transfer" process, or, for color/texture attribute information, as point recoloring.

[00300] However, applying geometry smoothing at the encoder prior to performing an attribute transfer may create a dependency between the geometry smoothing filter used to perform the geometry smoothing and the attribute transfer process. For example, since the attribute transfer process takes into account the smoothed geometry, a decoder may be limited to using the same smoothing filter as was used at an encoder in order to properly match the reconstructed geometry locations with the attribute positions. If not, there may be attribute mismatches and therefore distortions at each reconstructed 3D point. For example, an in-loop geometry smoothing filter used at an encoder (e.g. normative smoothing filter) may restrict the options of which smoothing filters may be used at a decoder. This is because the decoder must support the same geometry smoothing filter as was applied at the encoder. Also, an in-loop geometry smoothing filter (e.g. normative smoothing filter) may require that all points be decoded at the decoder for all layers of the point cloud. However, in some embodiments, it may be advantageous to only decode some, but not all of the layers. The use of an in-loop geometry smoothing filter at the encoder may restrict a decoder's ability to reconstruct a point cloud using some, but not all, of the layers of the point cloud.

[00301] For example, there may be a mismatch between the final reconstructed geometry values and the attributes associated with each point, since the attributes are expected to relate to the geometry points after the full smoothing process is performed. The differences in smoothing could potentially result in points associated with different geometry positions than the ones originally expected during the operation of the attribute transfer process at the encoder. This could result in some distortion when rendering the decoded attributes. Although some of this distortion could be alleviated if the decoder tries to correct the attributes based on its knowledge that these attributes were adjusted at the encoder based on the normative geometry smoothing scheme, however that may not always be possible because of the considerable processing cost such a method would require or because of the unavailability of the samples (e.g. in the case of not all layers being decoded). In particular, that method would require also computing the smoothed geometry of the points given the specified smoothing method, rendering these points with the decoded attributes, and then performing the attribute transfer

process, as was done in the encoder, using the points constructed with the desired smoothing process.

[00302] In some embodiments, instead of performing smoothing at the end of the reconstruction process for all layers, smoothing may instead be performed independently for each layer. That is, after coding the layer 0 information at the encoder, only that information, e.g. reconstructed geometry points from layer 0, is considered for smoothing the points that correspond to this layer during 2D to 3D reconstruction at the encoder. Furthermore, uncompressed points or other points coded with different coding schemes, such as the enhanced occupancy information or point local reconstruction reconstructed points, may be excluded from this smoothing process. Inclusion or exclusion of such points may be signaled using parameters or flags at different headers or high level syntax elements of the point cloud compression system, e.g. in the sequence parameter sets, point cloud frame parameter sets, or patch frame or tile group headers. Patches, including normal patches, may also have a parameter or flag that allows them to be explicitly excluded from or included into the smoothing process. A patch and its reconstructed points that is marked as excluded, for example, will not be considered for any smoothing operations, either for itself or for any neighboring points. Attribute transfer may then be performed given the smoothed points reconstructed from layer/map 0 and without needing to wait for any additional points from other maps that may also be encoded. This means that if those layers/maps are discarded there will be no impact on the quality of the attributes that are associated with the geometry positions. The geometry in this case, after smoothing, would match the one that the encoder also derived. After also reconstructing the next layer/map, e.g. map1, the points that correspond to map1 could also be smoothed as well. For these points only map1 points could be considered for smoothing. However, since commonly these points are already dependent to points already constructed from lower maps/layers, it should be acceptable that these points are smoothed. This applies to all subsequent maps. In one embodiment smoothing of points in a higher map/layer only considers pre-smoothed points. In another embodiment, smoothing of a higher map/layer takes into account the smoothed points from the lower maps/layers.

[00303] In some embodiments, it may be possible to control smoothing not only at the frame level but also at the map/layer level. Different control parameters could be signaled per map/layer. An encoder may select to perform smoothing of map0 given a particular window or

threshold, use a different window or threshold for map1, and/or completely disable smoothing for a different map/layer. This can allow for different complexity performance tradeoffs and also provide more fine control to the smoothing process given the possibility of using different quality conditions (e.g. quantization parameters QPs, lambda, or other parameters) when encoding a particular map or layer. For example, the quality of map1 may be much lower than the quality of map0. Such information could be signaled at a high level syntax structure element of the encoding system, e.g. the sequence parameter sets, the patch frame parameter sets, or for each patch frame or tile group header. There could be nominal values for these elements at higher elements (e.g. in the sequence parameter set SPS), and override values at lower high level syntax elements, e.g. in the patch frame parameter sets or patch frame or tile group header. The nominal values could specify global parameters that all pictures may have to follow, while the override parameters, if present would allow the encoder to override those nominal values.

[00304] It should be noted that if a system is aware that some layers/maps could be discarded, its encoder could also consider this fact during the attribute transfer process. In particular, it may decide to perform the attribute transfer process for map0 points assuming that only layer/map 0 points are reconstructed while map 1 points use the attribute process assuming all points are constructed. This could help the quality when reconstructing only map0 (and effectively reduced map level) points.

[00305] In another embodiment, geometry smoothing is excluded from the attribute transfer process at the encoder. For example, FIG. 6J illustrates an encoder that generates geometry smoothing parameters that are multiplexed into a bitstream without performing geometry smoothing at the encoder, or if geometry smoothing is performed at the encoder, performing the geometry smoothing subsequent to determining and performing attribute transfer functions, wherein the attribute transfer functions take into account compression/decompression distortion or artifacts of unsmoothed points that have not been subjected to geometry smoothing. The attributes are instead optimized (e.g. attribute transfer functions applied) for the geometry prior to geometry smoothing, which is always expected to be known to the decoder, regardless of what geometry smoothing scheme may be used later or of how many layers may be discarded/decoded. The decoder is aware that the attribute information was optimized for the geometry positions without geometry smoothing and can consider this if/when any kind or form of smoothing is performed. It should be noted that some

encoders may select to not perform the attribute transfer process, e.g. attributes are generated in an open loop manner, so as to save resources. It might be desirable in this case that a signal may be provided in the bitstream that states whether the attribute transfer process (on unsmoothed points) was performed or not at the encoder, while also providing information on how that attribute process was performed (e.g. through linear interpolation within a particular window). This may also be useful to the decoder. This signaling could be extended to also state if smoothing was considered for the attribute transfer. This again can be quite useful to the decoder to best determine the steps it should use for the reconstruction process.

[00306] Encoder 600 may be a similar encoder as encoder 200 described in FIG.2A, however with the non-normative smoothing processes as described above incorporated into the encoder. Encoder 600 receives an input cloud frame and 3D patch generation module 602 segments the point cloud into 3D patches that can be projected onto a two-dimensional patch plane to generate attribute and geometry patch images. Information about the input point cloud frame is also provided to the attribute image generation module 606 and geometry image generation module 616. For example the original point cloud frame may be used as a reference for determining distortion or artifacts. In some embodiments, patch segmentation and generation performed at 3D patch generation module 602 may be performed in a similar manner as described for decomposition into patches 206 shown in FIG. 2A and further described in FIGs. 3A-3E. The patch information generated by 3D patch generation module 602 may further be provided to geometry image generation module 616 for use in generating a 2D geometry patch, attribute image generation module 606 for use in generating an attribute patch, and patch sequence compression module 610, for example for use in determining patch sequence parameter sets to be signaled.

[00307] The patch information is also provided to smoothing module 606 which may determine smoothing parameters to be signaled. Also patch packing module 604 generates occupancy map information that is encoded via video compression module 622 and which may be reconstructed via video compression module 622 (e.g. video encoded and then video decoded) to generate reconstructed occupancy map information that is provided to image padding module 618, image padding module 608, attribute image generation module 606 and smoothing module 606. The reconstructed occupancy map information may enable the image padding modules 606 and 608 to distinguish between patch images and padded portions of an

image frame. Also, smoothing module 606 may ignore or devote less resources to pad portions of an image frame. Additionally, attribute image generation module may adapt encoding of patch attribute values at borders between the attribute patches and the padded portion to avoid distortion.

[00308] Attribute image generation module 606 in conjunction with smoothing module 606 may perform attribute smoothing by comparing a reconstructed 3D patch to an original 3D patch included in the patch information received from 3D patch generation module 602 and may provide smoothing information to smoothing module 606 for attribute smoothing. Also geometry image generation module 616 in conjunction with smoothing module 606 may perform geometry smoothing by comparing a reconstructed 3D patch to an original 3D patch included in the patch information received from 3D patch generation module 602. However, both the geometry smoothing and the attribute smoothing may be compared to the original 3D patches without geometry smoothing. In this way the geometry smoothing and the attribute smoothing are not dependent on one another. For example, an encoder could select to apply the attribute smoothing information, but apply its own geometry smoothing algorithm. This is because the attribute smoothing is not in reference to a smoothed version of the geometry, but instead the original 3D patch geometries.

[00309] Image padding modules 608 and 618 pad the image frames respectively packed with attribute patch images and geometry patch images. Also video compression modules 612 and 620 video encoded the respective attribute patch image frames and geometry patch image frames. Multiplexer multiplexes a patch sequence sub stream an attribute sub stream a geometry sub stream, an occupancy sub stream and smoothing parameters into a compressed bit stream that may be provided to a decoder to reconstruct a reconstructed version of the input point cloud frame.

[00310] If the attribute transfer process is performed in this manner, e.g. the attribute planes are created with the data prior to geometry smoothing being applied, then a decoder could consider this for improving the attribute values after a form of geometry smoothing is applied. In this case, the decoder would have knowledge of both the reconstructed geometry and the corresponding attributes prior to smoothing. If the decoder decides to perform attribute smoothing to the smoothed geometry, the new smoothed geometry could be used in

combination with the original, pre-smoothed geometry, to perform an attribute transfer step so as to adjust the attribute values given their new geometry positions. In this case, essentially, a new attribute transfer block is also introduced into the decoder, such as the decoder shown in FIG. 2B.

[00311] For example, FIG. 6K illustrates a decoder that includes an attribute transfer block 668 that receives attribute data along with pre-smoothed geometries and smoothed geometries. Although in this case some additional complexity has been introduced in the decoder, quality may be better guaranteed and controlled in the decoder. This method can work essentially with any geometry smoothing process, whether that process filters only patch edge boundaries, or if the process also filters all geometry samples regardless of whether they are on a patch edge boundary. Also, this process can work with filters that use different thresholds based on patch position, filtering that may utilize different weighting for a particular dimension (x, y, z) of a point and the relationship of that dimension with the patch, etc.

[00312] In some embodiments, if an attribute smoothing process is also specified in a bit stream, the attribute transfer process at the decoder could also be combined with the attribute smoothing process at the decoder so as to reduce the complexity of these two steps. That is, instead of performing the steps in sequence, the attribute transfer process could be combined with the attribute smoothing process and they can be applied together. For example, this is shown in FIG. 6K by including both attribute transfer and smoothing in one process block. Though, in some embodiments, attribute smoothing and attribute transfer could be performed serially at the decoder.

[00313] In some embodiments, attribute transfer and geometry smoothing may be combined into a common process at the decoder. In such embodiments, the geometry smoothing and attribute transfer may be performed in parallel for a plurality of points of the reconstructed point cloud. For example, geometry smoothing and attribute transfer could be performed point-by-point where a point location is moved to adjust for geometry smoothing and its updated attribute is also computed for the changed location. This could be done at the same time for multiple points (e.g. in parallel) for the reconstructed point cloud. The geometry smoothing method that is used could be determined at the decoder or could also be signaled to the decoder in a high level syntax element (SPS, patch frame parameter sets, patch frame or

tile group header etc.) or using Supplemental Enhancement Information (SEI) messages. It is also possible for a bitstream to indicate multiple possible options for geometry smoothing instead of only one, with different control parameters for each one, and to let the decoder determine based on its capabilities or characteristics (e.g. power requirements or status) which scheme to use. This could be done for both geometry smoothing and attribute smoothing. For example, the decoder may use a first filtering scheme if the decoder or a device that includes the decoder is connected to a permanent or external power source, such as an electrical outlet. Also, the decoder may use a second filtering scheme if the decoder or a device that includes the decoder is running off of a local battery. This may allow for less complex filtering schemes to be used when power is limited to conserve battery life, as an example. In some embodiments filtering/smoothing schemes may be independent selected at the decoder to smooth geometry and to smooth attributes.

[00314] Performing geometry smoothing outside of the attribute transfer loop at the encoder may allow smoothing to be seen as a purely post-processing step that is non-normative. For example, quality is guaranteed to be consistent across all decoders regardless of what geometry smoothing technique they may decide to utilize.

[00315] In some embodiments, a decoder, such as decoder 650 illustrated in FIG. 6K receives a compressed bit stream, such as may have been generated by encoder 600 illustrated in FIG. 6J. De-multiplexer separates the compressed bit stream out into sequence parameter set information that is parsed by sequence parameter set parser 654 and provided to geometry/attribute reconstruction module 664, geometry post-processing module 666, and attribute transfer and smoothing module 668. Additionally, the information parses from the sequence parameter set information may be provided to patch sequence decompression module 656 and video compression modules 658, 660, and 662.

[00316] Patch sequence decompression module 656 may be similar to auxiliary patch information compression module 238 illustrated in FIG. 2B and may determine patch information for the geometry and attribute patches of the bit stream.

[00317] Video decompression modules 658, 660, and 662 may video decompress encoded image frames comprising occupancy information, packed geometry patches, and

packed attribute patches, respectively. The patch information, occupancy map, geometry images, and attribute images may be provided to geometry and attribute reconstruction module 664, which may be similar to point cloud generation module 240 of decoder 230 as illustrated in FIG. 2B. However, in contrast to decoder 230 illustrated in FIG. 2B geometry and attribute smoothing may be performed as separate processes, wherein the attribute smoothing is able to receive pre-smoothed geometry to determine an attribute transfer function due to the geometry smoothing. For example, instead of including smoothing filter 244 as described in FIG. 2B for decoder 230, decoder 650 includes both geometry post-processing module 666 and attribute transfer and smoothing module 668. Note that contrasts between the decoder 230 of FIG. 2B and decoder 650 of FIG. 6K are given to illustrate different smoothing techniques. However, in some embodiments, smoothing techniques as described in FIGs. 6J or 6K may be incorporated into any of the other encoder and decoders described herein, such as the decoder 230 of FIG. 2B.

[00318] In some embodiments, an encoder may determine, for a point cloud, a plurality of patches, as described above in a patch segmentation process. Each of the patches may comprise points of the point cloud projected onto a patch plane. Also, the encoder may pack patch images (e.g. attribute patch images and/or geometry patch images) into the image frames. Thus, some image frames may comprise attribute patch images and may be referred to herein as attribute image frames, while other image frames may comprise corresponding geometry patch images that correspond to the attribute patch images, and that may be referred to herein as geometry image frames.

[00319] The encoder may video encode and video decode or otherwise compress and decompress the geometry image frames to determine distortion or artifacts introduced into the geometries due to encoding/decoding and/or compression and decompression. The encoder may further apply an attribute transfer function, at the encoder, to the attributes of the points included in the attribute image frames to compensate for the distortion and/or artifacts anticipated to be introduced due to encoding/decoding and/or compression and decompression. However, the encoder may refrain from applying a geometry smoothing filter to the geometry patch images during the encoding/decoding and/or compression and decompression. Instead the encoder may optionally determine geometry smoothing parameters to be applied at a decoder without applying the geometry smoothing parameters on points used at the encoder to

determine the attribute transfer functions. In this way, the attribute transfer functions may correctly be applied to points at a decoder that have not undergone a geometry smoothing filter. Thus, any decoder regardless of what type of smoothing filter it uses may be able to apply the attribute transfer function on similar geometries as were used to apply the attribute transfer function at the encoder.

[00320] In some embodiments, an encoder may include bitstream parameters indicating different smoothing filters to be applied at a decoder under different circumstances. For example, the encoder may indicate different smoothing filters to be applied to different layers of the point cloud.

[00321] In some embodiments, a decoder may receive an encoded bitstream comprising data for geometry image frames and data for attribute image frames of a point cloud. The geometry image frames may comprise geometry patch images for patches of the point cloud projected onto a patch plane. The attribute patch images may include attribute values that correspond to points of the geometry patch images. The decoder may be configured to decode the encoded bitstream to generate the attribute image frames and the geometry image frames. For example, the bitstream may be formatted as an encoded video bitstream and the decoder may utilize a video decoding standard to decode the encoded bitstream. The decoder may also apply a smoothing filter, at the decoder, which may be a user or designer selected smoothing filter that is non-normative to a point cloud compression standard used to compress the point cloud. In some embodiments, the smoothing filter may be applied in a 2D domain on the reconstructed geometry patch images or may be applied in a 3D domain on a reconstructed version of the point cloud, reconstructed from the geometry patch images. The decoder may compare the smoothed version of the geometry patch images and/or the smoothed version of the reconstructed point cloud to versions of the patch images or the reconstructed point cloud prior to applying the smoothing filter. Based on this comparison the decoder may determine attribute transfer functions to be applied to compensate for the smoothing. In some embodiments, smoothing compensation attribute transfer functions may be applied as a second set of attribute transfer functions, wherein a first set of attribute transfer functions are applied at the decoder to compensate for distortion and/or artifacts introduced into the geometry due to encoding/decoding and/or compression/decompression.

[00322] In some embodiments, the smoothing and/or smoothing compensation attribute transfer functions may be applied as part of a rendering process for the point cloud after the point cloud has been reconstructed using the geometry patch images and the attribute patch images.

[00323] In some embodiments, a decoder may recursively apply smoothing and attribute transfer functions, wherein the output of one is the input to the other such that the impacts of smoothing and attribute transfer are taken into account in both processes.

[00324] In some embodiments, a decoder may adaptively apply smoothing and/or attribute transfer functions on only portions of a point cloud to be reconstructed based on a view from which the reconstructed point cloud is to be viewed. For example, smoothing and/or attribute transfer functions may be applied to portions of the point cloud visible in the view, but may not be performed on portions of the point cloud hidden in the proposed view.

Bit Stream Structure for Compressed Point Cloud Data

[00325] As discussed above and in more detail below in regard to FIGs. 13 and 14, there is considerable interest in augmented and virtual reality applications and in the use and compression of 3 dimensional data to support them. One such form of data includes point cloud representations, where objects are specified as a series of points that are described in terms of 3D geometry and a set of attributes per point that may include information such as color, reflectance, time, or other types of information. Compression of such information is highly desirable given the amount of space and bandwidth such data would require if not compressed.

[00326] One method that has been proposed for compressing point cloud data is described above in regard to packing patches into video frames and may be further extended to achieve near lossless or lossless performance by further encoding points that are “missed” or not included in the patches.

[00327] In some embodiments, the point cloud data is first segmented into multiple 2D projected images/videos, each representing different types of information. Segmentation is

performed by dividing the point cloud into multiple patches that permit one to efficiently project the entire 3D space data onto 2D planes. Each patch is associated with information such as geometry, texture, and other attributes if they are available. Such information is then copied at the co-located locations on separate image sequences with each now containing only the geometry information, the texture information, and any other remaining attributes respectively. Auxiliary information that contains the patch information as well as an occupancy map that dictates which areas in these projected image sequences correspond to actual point cloud data and which are unoccupied, e.g. may contain no or dummy data (e.g. padded data), are also provided. Compression is then applied on such information using different strategies. Auxiliary information, for example, can be entropy coded, while occupancy maps may be down-converted and encoded using either conventional image/video codecs or other methods such as run length compression. The separate projected image sequences may be compressed using conventional codecs. This results in a collection of multiple sub streams, e.g. a geometry sub stream, texture and attribute sub streams, as well as occupancy and auxiliary information sub streams. All these streams are multiplexed together to generate the final point cloud bit stream as shown in the bit stream structure illustrated in FIG. 6C.

[00328] In some embodiments, the structure specified in FIG. 6C may be quite rigid and inflexible, and may not account for certain applications, especially low delay applications, that would require all information corresponding to a single point cloud frame in time to be efficiently signaled and decoded within a constrained time frame. The bit stream architecture illustrated in FIG. 6C may also impose considerable penalties in terms of memory and delay. In some embodiments, a point cloud video sequence is segmented into multiple groups of point cloud frames (GOFs). Group of Frames or GOFs may consist of multiple layers of information, with each one representing different types of data, such as geometry and texture information among others. In some embodiments, a point cloud compression PCC decoder is required to first decode and store the entire geometry video stream for each GOF, as well as any associated information with it, followed by the related texture video stream before starting to reconstruct each frame within a GOF (one may argue that point cloud reconstruction can follow the decoding order of the texture video stream). However, the memory requirements may be reduced by scanning the bit stream and finding the appropriate location of each sub-bit stream (e.g. geometry, occupancy/auxiliary info, texture) and decoding them in parallel. However, this assumes that such streams are restricted in using the same coding order and structures.

[00329] When all the data is sequentially signaled without any markers to indicate the positions of different sub streams, there may be a significant disadvantage of time delay. For example, one frame cannot be reconstructed until all the group of frame GOF information is decoded. Also, the bit stream cannot be decoded in parallel unless every data has information of its own size. To resolve this issue, in some embodiments the concept of a coding unit, which may be referred to herein as a PCCNAL (Point Cloud Compression Network Abstraction Layer) unit for convenience, that contains information on one or more types of data and its related header information may be used. Encapsulated data can be placed in any location within a bit stream and can be decoded and reconstructed in parallel.

[00330] In some embodiments, signaling methods of the parameters may not be defined or limited. The names of the parameters may not be limited as long as the parameters serve the same purpose. The actual value or code words of each parameter may not be limited as long as each function of the parameter is identified by the numbers.

[00331] For example, a bit stream structure for compressed Point Cloud Data that is more flexible and that permits the delivery of point cloud data for low delay applications may be used. The bit stream structure may also enable other features such as unequal error protection, reordering, and reduced memory footprint, among others. Furthermore, the parameters and/or component units which are used to identify the different methods and definitions used over the entire slice, frame, GOP, or sequence of the Point Cloud Data may also be considered in some embodiments. An example of a component unit that is defined and used within a point cloud compression PCC bit stream is the Point Cloud Compression Network Abstraction Layer (PCCNAL) unit. In particular, a PCCNAL unit may be defined as a set of data that contains one or more types of information and that can be placed anywhere in the bit stream. However, placement may be limited within a particular period.

[00332] Some other properties of the PCCNAL unit include:

- PCCNAL header: sequence of bits that indicates the start of the unit and/or the type of the unit. Such a header may contain a “start code” indicator that is a unique sequence that should not be present anywhere else within the PCCNAL,

and can help in identifying such a unit. Start code emulation prevention methods could be used to avoid the presence of equivalent signatures within the stream.

- PCCNAL index : index to identify different PCCNAL units
- PCCNAL size : size of the PCCNAL unit
- PCCNAL trailing bits : Such information is optional, and similar to the start code, this is a unique signature that can help in identifying the end of a PCCNAL unit
- PCCNAL GoF index : Corresponding GoF index to the PCCNAL units
- PCCNAL POC: An indexing parameter for such a unit. This index can be used to classify and/or identify each NAL unit and permit grouping of different NAL units based on its value. For example, a geometry and an attribute frame that correspond to the same Point Cloud frame can be given the same index, which helps identify their relationship later during decoding and reconstruction of the point cloud representation. This information may limit placement of PCCNAL units within the bit stream.

[00333] Each coded block or set of coded blocks can be identified as a PCCNAL unit. Such blocks can include sequence parameter sets, picture parameter sets, geometry video data, occupancy data, texture video data, geometry frame, occupancy frame and texture frame amongst others. For example, Geometry video stream in FIG. 7A can correspond to geometry video data PCCNAL(PCCNAL-GEO), auxiliary info & occupancy maps can correspond to PCCNAL-OCC and Texture video stream can correspond to PCCNAL-ATT. In an alternative embodiment, all of the geometry video data, occupancy data and texture video data can comprise one PCCNAL unit.

[00334] Examples of PCCNAL unit are as following:

- PCCNAL-SPS : set of parameters used and can be applied over the entire sequence
- PCCNAL-PPS : set of parameters used and can be applied over the entire frame/picture
- PCCNAL-GOF : set of parameters used and can be applied over the entire GOF
- PCCNAL-OCC : set of occupancy map information

- PCCNAL-GEO : set of geometry data information
- PCCNAL-ATT: set of texture data information
- PCCNAL-FRM : information on single frame
- PCCNAL-GEOFRM : geometry information on single frame
- PCCNAL-ATTFRM : texture information on single frame
- PCCNAL-OCCFRM : occupancy map information on single frame

[00335] The above information could also be defined for sub-frames, e.g. slices, group of coding tree units (CTUs) or macroblocks, tiles, or groups of slices or tiles. They can also be specified for a group of frames that does not necessarily need to be equal to the number of frames in a GOF. Such group of frames may be smaller or even larger than a GOF. In the case that this is smaller, it is expected that all frames inside this group would be a subset of a GOF. If larger, it is expected that the number would include several complete GOFs, which might not necessarily be of equal length. FIG. 7B is an example illustration of the conceptual structure of PCC encoded bit stream with PCCNAL units

[00336] In some embodiments, the PCCNAL units can be signaled sequentially without any marker.

[00337] In some embodiments, PCCNAL units can have a PCCNAL header, which may include a start code and/or contain PCCNAL trailing bits. The PCCNAL header is located at the beginning of a PCCNAL unit and the PCCNAL trailing bits are located the end of a PCCNAL unit. By having a PCCNAL header and/or a PCCNAL trailing bits, the decoder can jump to the point where the proper data is located without decode from the beginning to the data.

[00338] For example, in the PCCNAL header a start code can be included, which can help in detecting a PCCNAL unit. A start code is a unique sequence of bits that should not be used for representing any other data within such a unit. When such start code is detected, it may be known that the following bits would correspond to particular information relating to such a unit, including its identification information as well as any related payload that would correspond to such an identifier. For example, an identifier equal to 000000, assuming 6 bits

for the identifier, can indicate the PCCNAL is GoF Header Unit, while an identifier equal to 000001 can indicate that the payload includes Geometry Data information. Other identifiers could correspond to occupancy information, attributes, and so on and such could be defined by the application or user (e.g. engineer configuring the encoder/decoder). It should be pointed out that although start codes are present at the beginning of a particular unit, it might be possible to also define a “start code” that follows a fixed number of bits or syntax elements, which may be referred to herein as a “preamble” sequence. For example, the preamble sequence may include the unit identifier as well as the POCNAL POC parameter. If the parameters in the preamble sequence use variable arithmetic encoding, encoding them in right to left order in the bit stream (e.g. the least significant bit of the encoded parameter is written first in the stream and the most significant one is written last). This is not necessary, but could still be used for fixed length parameters.

[00339] In some embodiments, a PCCNAL header can contain the size of its own PCCNAL size instead of PCCNAL header bits.

[00340] In some embodiments, a PCCNAL header can have both PCCNAL size and PCCNAL header bits.

[00341] In some embodiments, a PCCNAL can have trailing bits to indicate the end of the PCCNAL unit.

[00342] In some embodiments, a PCCNAL can have its corresponding GoF index.

[00343] In some embodiments, a PCCNAL can have its corresponding POC index.

[00344] In some embodiments, a PCCNAL can have its corresponding a type identifier.

[00345] In some embodiments, with the PCCNAL header, PCCNAL units in a bit stream can be located without any fixed order. For example, in some embodiments PCCNAL units can be placed in any order within a bit stream, within the limitations of the PCCNAL POC. Reordering could still be performed during decoding or reconstruction using the value of PCCNAL POC. PCCNAL POC could be a periodic number however, and such reordering

should account for such a characteristic. In some embodiments, PCCNAL units can be grouped by their GoF index. In some embodiments, PCCNAL units can be grouped by their POC as depicted in FIG. 7B. In some embodiments, PCCNAL units can be grouped by their types as depicted in FIG. 7C.

[00346] In some embodiments, PCCNAL units can be signaled in different bit streams. Even when they are signaled separately they can be reconstructed properly by PCCNAL header information such as GoF index and/or POC.

[00347] For example, when an encoded PCC bit stream is received at the decoder, the decoder may start parsing PCCNAL unit headers. Using information in the headers, a decoder can jump through the bit stream to collect synced occupancy-geometry-texture data. If a header has the size of the PCCNAL unit, it may jump to the end by the size. If a header only contains a start code, it may read through the bit stream until it encounters a new header or a trailing bits sequence. The decoder can also analyze the PCCNAL POC information for each PCCNAL, determine which units contain the same information and then group and reorder them. Such process can permit the compressed point cloud data to be properly decoded and then reconstructed, e.g. by determining which frame in the geometry and attribute video signals correspond to the same point cloud frame and could be used for its reconstruction. This is a similar mechanism as used in scalable video codecs where the decoder scans through the bit stream and determines correspondence of base and enhancement layers based on their POCs.

[00348] In an encoded PCC bit stream, there can be several parameters per slice, per frame/picture, per GOP, or per sequence of Point Cloud Data, which signal information that permits proper decoding and rendering of the point cloud data. The parameters can be present in the bit stream more than one once and at different locations. For example, a parameter can be signaled at both the sequence level and at the slice level. In this case, the parameter at the lower level can overwrite the one at the higher level within the level's scope. In another embodiment, the parameter at the lower level can provide additional information that can clarify the characteristics of the parameter at the higher level. Set of these parameters can comprise a PCCNAL unit. Some example of such parameters include the following:

- PCC frame width, PCC frame height: the “nominal” width and the height of the frame that the PCC data is mapped. The size can be the same as the size of the output of the video codec. The size can be different from the size of the output of the video codec. In this case the outputs can be resized by a method indicated in the parameter sets or predefined by the user/codec.
- Resizing type : type of resizing method from decoded video size to PCC frame size
- Group of Frames size: the number of frames in one group of frames can be signaled.
- Chroma format: Chroma format of the geometry data video and texture data video can be signaled. If necessary, Chroma format of occupancy map can be signaled as well. The format can be signaled once for both video layers or can be signaled separately for each video layer. Such information could also be inferred from the video bit stream and does not necessarily need to be present in the PCCNAL unit again.
- Input, output bit depth: This syntax defines the bit depth of input PCC data and output PCC data are signaled.
- Internal bit depth: This syntax element defines the bit depth of the data for internal computation in the PCC. During the internal computation, the input data is adjusted to be within the range of internal bit depth. Such information could also be inferred from the video bit stream and does not necessarily need to be present in the PCCNAL unit again.
- Type of the video codec: This syntax element defines the video codec, e.g. AVC, HEVC, AV1 or some other codec, as well as the corresponding profile and level information, that is used for encoding the Geometry and Attribute projected video data. Such a syntax element can be signaled once for both the Geometry and Attribute video signals, or can be signaled independently for each video signal. Such information could also be omitted and be inferred by the characteristics of and information within the video stream.
- Layers for each stream
 - Presence of layers : a flag that indicates that there are more than 1 layers for the geometry data/attribute data/occupancy map in the bit stream

- Number of layers: in the case that the layers are more than 1, the number of layers is also signaled. This syntax element defines the number of layers that the Geometry and Attributes data video have. Each layer contains information about the points mapped to a same pixel in a patch but each one corresponds to a different depths.
- Minimum number of layers: This is an optional syntax element that defines the minimum number of layers present in the bit streams.
- Each video layer can use a different type of a video codec. The type of the video codec used for a particular layers can be signaled.
- Occupancy map
 - Presence of an occupancy map: a flag that indicates the presence of occupancy map in the bit stream
 - Coding type of the occupancy map: in case that occupancy map is present, the type of the coding method used for the occupancy map is also signaled. For example, the occupancy map can be coded with a video codec or another method defined in the specification.

Example Methods of Compressing and Decompressing Point Clouds

[00349] FIG. 8A illustrates a process for compressing attribute and spatial information of a point cloud, according to some embodiments.

[00350] At 802, a point cloud is received by an encoder. The point cloud may be captured, for example by one or more sensors, or may be generated, for example in software.

[00351] At 804, compressed point cloud information is determined, using any of the techniques described herein or using one more combinations of the techniques described herein.

[00352] At 806, a compressed point cloud is encoded using the compressed point cloud information determined at 804. The point cloud may be compressed using any of the techniques described herein.

[00353] FIG. 8B illustrates a process for decompressing attribute and spatial information of a point cloud, according to some embodiments.

[00354] At 803 an encoded point cloud is received. The point cloud may have been encoded using any of the encoding techniques described herein, such as patch images packed into an image frame that is then encoded by a video encoder. In some embodiments, the encoded point cloud may comprise point cloud projections, such as projections onto a cube, cylinder, sphere, etc. that are then encoded via a video encoder.

[00355] At 805, spatial and attribute information for the encoded point cloud is determined. For example, a video decoder may be used to decode video encoded packed images or projects. Spatial information may then be determined based on the packed images or projections and combined to determine spatial information for points of the point cloud. For example, depth information for points of a patch may be matched with X and Y information for the points of the patch to determine spatial information for the points of the patch in 3D space. In a similar manner other attributes, included in patch images such as color attributes, texture attributes, etc. may be matched with corresponding points to determine attribute values for the points. Also, in the case of multiple projections, the same point may be identified in more than one of the projections to determine spatial information for the point in 3D space.

[00356] At 807, a decompressed point cloud may be provided to a recipient device or module.

[00357] FIG. 8C illustrates patch images being generated and packed into an image frame to compress attribute and spatial information of a point cloud, according to some embodiments.

[00358] At 810, patches are determined for portions of point cloud. For example patches may be determined as described above. At 825 patch information for the patches may be generated and at 826, may be encoded to be sent to a decoder. In some embodiments, encoded patch information may be separately encoded from one or more image frames comprising packed patch images.

[00359] At 811, a first patch (or next patch is selected). At 812 a color (e.g. attribute) patch image is generated for the points of the point cloud included in the patch. At 814, one or more additional attribute images, such as a texture attribute image, are generated for the points of the point cloud included in the patch.

[00360] At 813, spatial information images are generated for the points of the point cloud included in the patch. In some embodiments, to generate the spatial information images, the points of the point cloud are projected, at 815, onto a patch plane perpendicular to a normal vector normal to a surface of the point cloud at the patch location. At 817 a first spatial image is generated for the patch based on the points being projected on the patch plane at 815. In addition, depth information for the points of the patch relative to the patch plane is determined at 816, and at 818 a depth patch image is generated based on the depth information determined at 816.

[00361] At 819, it is determined whether there are additional patches for which patch images are to be generated. If so, the process reverts to 811 for the next patch. If not, at 820 the patch images for the patches are packed into one or more image frames. In some embodiments, patch images for respective patches may be packed before patch images are determined for other patches. At 821, an occupancy map is generated based on where the patch images were placed when being packed into the one or more image frames. At 824, the occupancy map is encoded. As discussed above, in some embodiments, the occupancy map may be encoded using an arithmetic encoder, entropy encoder etc. Also, in some embodiments, the occupancy map may be encoded using a video encoder, wherein the occupancy map is organized as an additional image frame that corresponds with a patch image frame and that represents portions of the patch image frame that are occupied with patch images (e.g. occupied pixels) and portions of the patch image frame that are padded (e.g. non-occupied pixels). Video encoding of an occupancy map is discussed in more detail below in FIGs. 12A-12C.

[00362] At 822, spaces in the one or more image frames that are not occupied by patch images are padded. In some embodiments, an occupancy map for a patch image frame may be generated before or after the patch image frame is padded at 822.

[00363] At 823, the one or more image frames are video encoded, such as in accordance with a high efficiency video coding (HEVC) standard. In some embodiments, in which an occupancy map is represented by an occupancy map video image frame, the occupancy map video image frame may be video encoded at 823.

[00364] FIG. 9 illustrates patch images being generated and packed into an image frame to compress attribute and spatial information of a moving or changing point cloud, according to some embodiments.

[00365] At 930, point cloud information for a previously encoded point cloud is received wherein the point cloud information represents a subsequent version of the previously encoded point cloud. For example, the subsequent version may be a representation of the point cloud at a subsequent moment in time, wherein the point cloud is moving or changing as time progresses.

[00366] At 931, it is determined if any new patches need to be determined for the point cloud. For example, an object not currently in the previously encoded point cloud may have been added to the point cloud. For example, the point cloud may be a point cloud of a road and a ball may have entered into the road. If there is a need to add a new patch, the occupancy map is updated at 933 to include the new patch and encoded at 934. Also, at 932 patch images are generated for the new patch in similar manner as described in 812-814. The generated patch images are included in packing at 943.

[00367] At 935, a first or next patch of the patches generated for the reference (previous) point cloud is selected. At 936, the points of the patch are re-sampled as described herein. At 937 motion vectors for the points included in the selected patch between the reference point cloud and the current point cloud are determined. At 940 the motion vectors are used to generate a relative motion patch image. For example, in some embodiments, generating a relative motion patch image may comprise, encoding, at 941, vector motion in different directions using different image characteristics, as described herein. At 938 an updated color patch image is generated. In some embodiments, the updated color patch image may encode residual values indicating differences in colors of the points of the point cloud included in the

patch between the reference point cloud and the current point cloud. In a similar manner, at 939, other attribute update patch images may be generated.

[00368] At 942, it is determined whether there are additional patches to be evaluated. If so, the process reverts to 935 for the next patch. If not, at 943 the patch images for the patches are packed into one or more image frames. In some embodiments, patch images for respective patches may be packed before patch images are determined for other patches.

[00369] At 944, spaces in the one or more image frames that are not occupied by patch images are padded.

[00370] At 945, the one or more image frames are video encoded, such as in accordance with a high efficiency video coding (HEVC) standard.

[00371] FIG. 10 illustrates a decoder receiving image frames comprising patch images, patch information, and an occupancy map, and generating a decompressed representation of a point cloud, according to some embodiments.

[00372] At 1050, an occupancy map is received by a decoder, at 1051 patch information is received by the decoder. In some embodiments the occupancy map and the patch information may be encoded and the decoder may decode the occupancy map and the patch information (not shown). At 1052, the decoder receives one or more encoded video image frames. At 1052 the decoder identifies patch images in the one or more encoded video image frames and at 1054 the decoder decodes the encoded video image frames. In some embodiments, the decoder may utilize the occupancy map and the patch information to identify active and non-active portions of the one or more encoded video images and may adjust one or more decoded parameters used to decode the encoded video images based on whether portions, e.g. blocks, sub-blocks, pixels, etc. comprise active or non-active information.

[00373] At 1055, the decoder determines spatial information and/or attribute information for the points of the respective patches and at 1056 generates a decompressed representation of the point cloud encoded in the one or more encoded video images.

[00374] In some embodiments, active and non-active portions of an image frame may be indicated by a “mask.” For example, a mask may indicate a portion of an image that is a padding portion or may indicate non-active points of a point cloud, such as points that are hidden from view in one or more viewing angles.

[00375] In some embodiments, a “mask” may be encoded along with patch images or projections. In some embodiments, a “mask” may show “active/available” points and “non-active/non-available” points in space. In some embodiments, a mask may be independent from a texture and a depth patch image. In some embodiments, a mask may be combined with other information, such as a texture or depth patch image. For example, by indicating that certain values in a signal range correspond to active points, e.g. values above 16 and below 235 in an 8 bit image, and that other values correspond to non-active points, e.g. values below 16 or values above 235 in an 8 bit image. In some embodiments, additional considerations may be taken to avoid or reduce contamination between active and non-active regions. For example, it may be necessary to make use of lossless or visually lossless coding at the boundaries between active and non-active regions.

[00376] In some embodiments, a mask may be utilized in a variety of ways for improving coding efficiency. For example, a mask may be used with projection methods such as cylindrical, spherical or multiple projection as well as decomposition into patches. In addition, a mask may be used with a cubic projection method.

[00377] FIG. 11A illustrates an encoder, adjusting encoding based on one or more masks for a point cloud, according to some embodiments.

[00378] At 1162, an encoder receives a point cloud. At 1164, the encoder generate multiple projections or patch images as described herein, for the received point cloud. At 1166, the encoder determines one or more masks. The masks may be hidden points, padded portions of an image frame, points not viewable from a particular view-point, etc. At 1168, the encoder adjusts one or more encoding parameters based on the masks. For example the encoder may adjust a budget allocated to masked portions. Additional adjustments that an encoder may perform are described. At 1168, the encoder encodes a compressed point cloud, for example via one or more video encoded image frames.

[00379] FIG. 11B illustrates a decoder, adjusting decoding based on one or more masks for a point cloud, according to some embodiments.

[00380] At 1170, a decoder receives an encoded point cloud. At 1172, the decoder determines one or more masks for portions of the encoded point cloud. For example, the encoder may determine portions of image frames representing the compressed point cloud correspond to padding. Or, for a particular view of the point cloud being rendered by the decoder, the decoder may determine that one or more points of the compressed point cloud are not viewable from the particular point of view. In some embodiments, mask information may indicate which points are hidden when the point cloud is viewed from particular points of view. At 1174, the decoder adjusts one or more decoding parameters based on the masks. Adjustments that may be made by a decoder based on active/non-active regions or points (e.g. masks) are described in more detail below. At 1176 the decoder decodes the compressed point cloud.

[00381] In some embodiments, a mask may be used when performing motion estimation and mode decision. Commonly distortion is computed for an entire block. However, some blocks may have blocks that contain a combination of texture data as well as empty/nonvisible areas. For these areas only the textured data are of interest and any distortion in the non-visible areas may be ignored. Therefore, since commonly when performing such processes as motion estimation and mode decision, a distortion computation, such as Sum of Absolute Differences (SAD) or Sum of Square Errors (SSE), is performed, a mask may be used to alter the computation to exclude distortion for the non-visible areas. For example, for the SAD case, distortion may be computed by computing the sum of absolute differences of only samples in a block that correspond to a visible area in a current image. All other samples may be ignored during the computation. In some embodiments, distortion may be normalized at the pixel level thus avoiding having to consider blocks with different number of pixels.

[00382] In some embodiments, instead of only considering non-visible samples, samples that are adjacent to non-visible samples, or samples identified to correspond to different projections (but are placed when encoding within the same coding block) may be assigned different weights. For example samples in particular blocks could be considered more

important for subjective quality, and a lower distortion tolerance may be assigned. In such case, the weighting for those samples may be increased, thus biasing decisions where the distortion for those samples is lower. Knowledge also that different samples in the same block of a particular size $M \times N$ during motion estimation or mode decision correspond to different objects, may also help with the determination of the block partitioning mode, e.g. the encoder could make an early decision (based potentially on a preliminary search) on whether different partitioning could/should be used.

[00383] In some embodiments, masks may be used for rate control and rate allocation. For example, it may be desirable that blocks that correspond to areas that contain both visible and non-visible samples be encoded at a different, and some times higher, quality than blocks that contain only visible samples. This is done so as to avoid leakage between visible and not visible samples and ensure the best quality at the point-clouds “boundaries”. Different quality may also be assigned based on depth information, which may also be available on the encoder. Flatter areas may tolerate much more distortion than areas with considerable variance in depth. Control of quality may be performed by adjusting quantization parameters/factors, but also by adjusting other parameters such as the lagrangian multiplier during mode decision, using different quantization matrices if available, enabling and/or adjusting quantization thresholding and the size and/or shapes of zonal quantization.

[00384] Quantization may also be adjusted according to the projection method used. If, for example an equirectangular projection method was used to project the object onto a sphere and then onto a 2D plane, it might be desirable to increase quantization on the top and bottom boundaries, and slowly decrease it when moving towards the center/equator. This may help compensate for some of the differences in resolution allocation when using a particular projection method. Different adjustments may also be made to the different color components, again based on similar assumptions, and in consideration again of the mask information.

[00385] Quantization may also be performed while considering whether a sample is a visible or a non-visible sample. For example, if a strategy involves the use of dynamic programming/trellis quantization methods for determining the value of a quantized coefficient. In such embodiments, an impact in distortion of a quantized coefficient, as well as its impact on bitrate at multiple reconstruction points may commonly be computed. This may be done for

all coefficients while considering their bitrate interactions. Finally a decision may be made for all coefficients jointly by selecting the quantized values that would together result in the best rate distortion performance. In some embodiments, the visible and non-visible areas may be considered when computing such metrics.

[00386] Similar to the motion estimation and mode decision processes, sample adaptive offset (SAO) techniques also commonly compute the resulting distortion for each possible mode or SAO value that may be used. Again, the decision may exclude non-visible samples, or prioritize, with different weights samples that are close to non-visible samples or samples that correspond to areas with considerably varying depth.

[00387] In some embodiments, masks may be used in any other coding process that may involve a distortion computation.

[00388] In some embodiments, masks may be used in preprocessing/prefiltering. For example, samples may be prefiltered based on their proximity to non-visible samples so as to reduce the possibility of artifacts and/or remove noise that may make encoding more difficult. Any form of prefiltering, including spatio-temporal filters, may be used.

[00389] In some embodiments, prefiltering may be applied to both texture as well as depth information.

[00390] Decisions in quantization parameters could also be made at the picture level (temporally) given the amount of visible/non-visible samples and depth variance on different pictures. Such decisions could be quite useful, for example, in a multi-pass coding system where analyze the entire sequence is first analyzed to determine the complexity and relationship of each frame with other frames. The coding parameters may then be decided that will be used for that frame in relationship to all other frames and given an expected quality or bitrate target. Similar decisions may also be made, not only for quantization parameters, but also for the picture coding types (i.e. I, P, or B), structures (e.g. hierarchical or not coding of N frames that follows a particular coding order of frames), references to use, weighting parameters, etc.

Encoding and Decoding (normative concepts)

[00391] Since a mask is likely to be available losslessly or visually losslessly at the decoder, as well as the depth information, this information may also be used at the decoder (and of course at the encoder) to further improve quality.

[00392] For example, deblocking and sample adaptive offset (SAO), as well as adaptive loop filtering (ALF) and deringing (in codecs that support such mechanisms), with exclusion of non-visible samples, samples that correspond to different projections, or samples with very different depth characteristics may use masking information. Instead, it may be desirable to only consider for such filtering methods samples that correspond to the same projection and are not so far from each other (depth wise). This may reduce blockiness and/or other artifacts that these methods try to mitigate. Other future types of in-loop post filtering may also be performed in a similar manner.

[00393] As another example, out of loop post filtering with visible/non-visible/different area segmentation may utilize masking information.

[00394] Implicit adjustment of QP quality parameters based on a certain percentage of visible/non-visible samples within a block may be performed. This may reduce signaling of coding parameters if such switching occurs frequently in a bit stream.

[00395] Adjustment of the transform type based on the percentage of visible/non-visible samples may be performed, including the consideration of shape adaptive discrete cosine transforms (DCT transforms).

[00396] Adjustment of overlapped block motion compensation techniques may utilize masking information, if existing in a codec, to mask away non-visible samples. A similar consideration may be performed for block motion compensation and/or intra prediction (including an intra block copy method). Samples that are considered visible may be considered when constructing a prediction signal, including also when interpolating to perform subpixel motion compensation or when performing bi-prediction. Masks from the current picture may be considered, but if desired, both the masks from the current picture as well as the masks

corresponding to the reference pictures could be considered. Such considerations may be made adaptive at the encoder, through some form of signaling, i.e. at the sequence, picture, tile, slice, or even CTU/block level.

[00397] In some embodiments, clipping of the final value based on the mask or depth information may be performed.

[00398] In some embodiments, other prediction methods that may exist inside a codec (e.g. in AV1 or the Versatile Video Coding (VVC) standard currently being developed by the JVET team in MPEG) may be similarly adjusted or constrained based on the existence (and amount) of visible and non-visible points, and points corresponding to different projections.

[00399] In some embodiments, different control/adjustments may be applied to different color components as well as to the depth information.

Methods of Occupancy Map Compression

Arithmetic Compression

[00400] FIG. 12A illustrates more detail regarding compression of an occupancy map, according to some embodiments. The steps shown in FIG. 12A may be performed as part of steps 821 or 933 as described above. In some embodiments, any of the occupancy map compression techniques described herein may be performed at 821 or 933.

[00401] At 1280 a list of candidate patches is determined for each block or modified block of an occupancy map.

[00402] At 1281, the lists of candidate patches for each block are ordered in a reverse order as an order in which the patches were packed into the image frame. For example, the patches may be packed into an image, with larger patches packed before smaller patches. In contrast, the candidate list for each block of an occupancy map may include smaller patches before larger patches. At 1282, an arithmetic encoder may be used to encode the patch candidate list for each block. In some embodiments, an entropy encoder may be used. Also, in some

embodiments, empty blocks may be assigned a special value, such as zero, whereas patch candidates may be assigned numbers corresponding to a patch number, such as 1, 2, 3, etc.

[00403] At 1283, for each block sub-blocks are determined according to a determined precision value. The determined precision value may be encoded with the occupancy map such that a decoder may determine the determined precision value used at the encoder.

[00404] At 1284, for each block, a binary value (e.g. 0 or 1) is determined for each sub-block of the block. Full sub-blocks are assigned a different binary value than non-full sub-blocks. If all sub-blocks of a block are full, the block may be assigned a binary “full” value.

[00405] At 1285, for each non-full sub-block, a traversal order is determined. For example, any of the example traversal orders shown in FIG. 12B (or other traversal orders) may be determined. A run-length encoding strategy as described above in regard to occupancy map compression may be used to encode the binary values for the sub-blocks using the determined traversal order.

[00406] FIG. 12B illustrates example blocks and traversal patterns for compressing an occupancy map, according to some embodiments. The traversal patterns may be used as described above in regard to occupancy map compression and in FIG. 12A. For example, FIG. 12B illustrates block 1286 of an occupancy map that includes multiple sub-blocks 1287.

Video-Based Compression

[00407] FIG. 12C illustrates more detail regarding compression of an occupancy map, according to some embodiments. The steps shown in FIG. 12C may be performed as part of steps 821 or 933 as described above. In some embodiments, any of the occupancy map compression techniques described herein may be performed at 821 or 933.

[00408] At 1290, for each patch image frame, such as image frames comprising depth information patches or attribute value patches, a corresponding occupancy map image frame is generated. The occupancy map image frame may have a same frame size as the patch image frame and when placed over the patch image frame the pixels of the occupancy map image

frame may match up with corresponding pixels in the patch image frame. Because of this, a binary value may be assigned to each of the pixels of the occupancy map image frames to indicate whether the same corresponding pixel in the patch image frame is an occupied pixel or a padded pixel. In some embodiments, an occupancy map image frame may be smaller than its corresponding patch image frame. In such embodiments, different values may be assigned to the occupancy map image frame pixel to indicate whether its corresponding pixels in the patch image frame are occupied or padded. For example, a single occupancy map image frame pixel may correspond to multiple patch image frame pixels, wherein a first value indicates a first combination of occupied and unoccupied pixels in the patch image frame and another value indicates a different combination. As an example, say a single occupancy map pixel corresponds to two patch image map pixels. In such an embodiment, a first value in the occupancy map for the occupancy map pixel may indicate that both the patch image pixels are un-occupied, a second value may indicate that both are occupied, a third value may indicate that an upper one of the two pixels is occupied and the other is un-occupied and a fourth value may indicate that a lower one of the two pixels is occupied and the other is un-occupied. For example, each block of the occupancy map may be a multiple larger than a block of the patch image frame (e.g. the occupancy map may have a lower resolution than the patch image frame). Different color values (e.g. the 1st, 2nd, 3rd, 4th value, etc.) may represent sub-divisions of the occupancy map that correspond with multiple pixels of the patch image frame.

[00409] At 1292 a list of candidate patches is determined for each block of the patch image frames.

[00410] At 1294, the lists of candidate patches for each block are ordered in a reverse order as an order in which the patches were packed into the image frame. For example, the patches may be packed into an image, with larger patches packed before smaller patches. In contrast, the candidate list for each block of the patch image frame may include smaller patches before larger patches.

[00411] At 1296, the occupancy map image frames are video encoded.

[00412] At 1298, an arithmetic encoder may be used to encode auxiliary information, such as the patch candidate list for each block. In some embodiments, an entropy encoder may be used.

Example Applications Using Point Cloud Encoders and Decoders

[00413] FIG. 13 illustrates compressed point clouds being used in a 3-D application, according to some embodiments.

[00414] In some embodiments, a sensor, such as sensor 102, an encoder, such as encoder 104 or any of the other encoders described herein, and a decoder, such as decoder 116 or any of the decoders described herein, may be used to communicate point clouds in a 3-D application. For example, a sensor, such as sensor 102, at 1302 may capture a 3D image and at 1304, the sensor or a processor associated with the sensor may perform a 3D reconstruction based on sensed data to generate a point cloud.

[00415] At 1306, an encoder such as encoder 104 may compress the point cloud and at 1308 the encoder or a post processor may packetize and transmit the compressed point cloud, via a network 1310. At 1312, the packets may be received at a destination location that includes a decoder, such as decoder 116. The decoder may decompress the point cloud at 1314 and the decompressed point cloud may be rendered at 1316. In some embodiments a 3-D application may transmit point cloud data in real time such that a display at 1316 represents images being observed at 1302. For example, a camera in a canyon may allow a remote user to experience walking through a virtual canyon at 1316.

[00416] FIG. 14 illustrates compressed point clouds being used in a virtual reality (VR) or augmented reality (AR) application, according to some embodiments.

[00417] In some embodiments, point clouds may be generated in software (for example as opposed to being captured by a sensor). For example, at 1402 virtual reality or augmented reality content is produced. The virtual reality or augmented reality content may include point cloud data and non-point cloud data. For example, a non-point cloud character may traverse a landscape represented by point clouds, as one example. At 1404, the point cloud data may be

compressed and at 1406 the compressed point cloud data and non-point cloud data may be packetized and transmitted via a network 1408. For example, the virtual reality or augmented reality content produced at 1402 may be produced at a remote server and communicated to a VR or AR content consumer via network 1408. At 1410, the packets may be received and synchronized at the VR or AR consumer's device. A decoder operating at the VR or AR consumer's device may decompress the compressed point cloud at 1412 and the point cloud and non-point cloud data may be rendered in real time, for example in a head mounted display of the VR or AR consumer's device. In some embodiments, point cloud data may be generated, compressed, decompressed, and rendered responsive to the VR or AR consumer manipulating the head mounted display to look in different directions.

[00418] In some embodiments, point cloud compression as described herein may be used in various other applications, such as geographic information systems, sports replay broadcasting, museum displays, autonomous navigation, etc.

Example Computer System

[00419] FIG. 15 illustrates an example computer system 1500 that may implement an encoder or decoder or any other ones of the components described herein, (e.g., any of the components described above with reference to FIGS. 1-14), in accordance with some embodiments. The computer system 1500 may be configured to execute any or all of the embodiments described above. In different embodiments, computer system 1500 may be any of various types of devices, including, but not limited to, a personal computer system, desktop computer, laptop, notebook, tablet, slate, pad, or netbook computer, mainframe computer system, handheld computer, workstation, network computer, a camera, a set top box, a mobile device, a consumer device, video game console, handheld video game device, application server, storage device, a television, a video recording device, a peripheral device such as a switch, modem, router, or in general any type of computing or electronic device.

[00420] Various embodiments of a point cloud encoder or decoder, as described herein may be executed in one or more computer systems 1500, which may interact with various other devices. Note that any component, action, or functionality described above with respect to FIGS. 1-14 may be implemented on one or more computers configured as computer system

1500 of FIG. 15, according to various embodiments. In the illustrated embodiment, computer system 1500 includes one or more processors 1510 coupled to a system memory 1520 via an input/output (I/O) interface 1530. Computer system 1500 further includes a network interface 1540 coupled to I/O interface 1530, and one or more input/output devices 1550, such as cursor control device 1560, keyboard 1570, and display(s) 1580. In some cases, it is contemplated that embodiments may be implemented using a single instance of computer system 1500, while in other embodiments multiple such systems, or multiple nodes making up computer system 1500, may be configured to host different portions or instances of embodiments. For example, in one embodiment some elements may be implemented via one or more nodes of computer system 1500 that are distinct from those nodes implementing other elements.

[00421] In various embodiments, computer system 1500 may be a uniprocessor system including one processor 1510, or a multiprocessor system including several processors 1510 (e.g., two, four, eight, or another suitable number). Processors 1510 may be any suitable processor capable of executing instructions. For example, in various embodiments processors 1510 may be general-purpose or embedded processors implementing any of a variety of instruction set architectures (ISAs), such as the x86, PowerPC, SPARC, or MIPS ISAs, or any other suitable ISA. In multiprocessor systems, each of processors 1510 may commonly, but not necessarily, implement the same ISA.

[00422] System memory 1520 may be configured to store point cloud compression or point cloud decompression program instructions 1522 and/or sensor data accessible by processor 1510. In various embodiments, system memory 1520 may be implemented using any suitable memory technology, such as static random access memory (SRAM), synchronous dynamic RAM (SDRAM), nonvolatile/Flash-type memory, or any other type of memory. In the illustrated embodiment, program instructions 1522 may be configured to implement an image sensor control application incorporating any of the functionality described above. In some embodiments, program instructions and/or data may be received, sent or stored upon different types of computer-accessible media or on similar media separate from system memory 1520 or computer system 1500. While computer system 1500 is described as implementing the functionality of functional blocks of previous Figures, any of the functionality described herein may be implemented via such a computer system.

[00423] In one embodiment, I/O interface 1530 may be configured to coordinate I/O traffic between processor 1510, system memory 1520, and any peripheral devices in the device, including network interface 1540 or other peripheral interfaces, such as input/output devices 1550. In some embodiments, I/O interface 1530 may perform any necessary protocol, timing or other data transformations to convert data signals from one component (e.g., system memory 1520) into a format suitable for use by another component (e.g., processor 1510). In some embodiments, I/O interface 1530 may include support for devices attached through various types of peripheral buses, such as a variant of the Peripheral Component Interconnect (PCI) bus standard or the Universal Serial Bus (USB) standard, for example. In some embodiments, the function of I/O interface 1530 may be split into two or more separate components, such as a north bridge and a south bridge, for example. Also, in some embodiments some or all of the functionality of I/O interface 1530, such as an interface to system memory 1520, may be incorporated directly into processor 1510.

[00424] Network interface 1540 may be configured to allow data to be exchanged between computer system 1500 and other devices attached to a network 1585 (e.g., carrier or agent devices) or between nodes of computer system 1500. Network 1585 may in various embodiments include one or more networks including but not limited to Local Area Networks (LANs) (e.g., an Ethernet or corporate network), Wide Area Networks (WANs) (e.g., the Internet), wireless data networks, some other electronic data network, or some combination thereof. In various embodiments, network interface 1540 may support communication via wired or wireless general data networks, such as any suitable type of Ethernet network, for example; via telecommunications/telephony networks such as analog voice networks or digital fiber communications networks; via storage area networks such as Fibre Channel SANs, or via any other suitable type of network and/or protocol.

[00425] Input/output devices 1550 may, in some embodiments, include one or more display terminals, keyboards, keypads, touchpads, scanning devices, voice or optical recognition devices, or any other devices suitable for entering or accessing data by one or more computer systems 1500. Multiple input/output devices 1550 may be present in computer system 1500 or may be distributed on various nodes of computer system 1500. In some embodiments, similar input/output devices may be separate from computer system 1500 and may interact with one

or more nodes of computer system 1500 through a wired or wireless connection, such as over network interface 1540.

[00426] As shown in FIG. 15, memory 1520 may include program instructions 1522, which may be processor-executable to implement any element or action described above. In one embodiment, the program instructions may implement the methods described above. In other embodiments, different elements and data may be included. Note that data may include any data or information described above.

[00427] Those skilled in the art will appreciate that computer system 1500 is merely illustrative and is not intended to limit the scope of embodiments. In particular, the computer system and devices may include any combination of hardware or software that can perform the indicated functions, including computers, network devices, Internet appliances, PDAs, wireless phones, pagers, etc. Computer system 1500 may also be connected to other devices that are not illustrated, or instead may operate as a stand-alone system. In addition, the functionality provided by the illustrated components may in some embodiments be combined in fewer components or distributed in additional components. Similarly, in some embodiments, the functionality of some of the illustrated components may not be provided and/or other additional functionality may be available.

[00428] Those skilled in the art will also appreciate that, while various items are illustrated as being stored in memory or on storage while being used, these items or portions of them may be transferred between memory and other storage devices for purposes of memory management and data integrity. Alternatively, in other embodiments some or all of the software components may execute in memory on another device and communicate with the illustrated computer system via inter-computer communication. Some or all of the system components or data structures may also be stored (e.g., as instructions or structured data) on a computer-accessible medium or a portable article to be read by an appropriate drive, various examples of which are described above. In some embodiments, instructions stored on a computer-accessible medium separate from computer system 1500 may be transmitted to computer system 1500 via transmission media or signals such as electrical, electromagnetic, or digital signals, conveyed via a communication medium such as a network and/or a wireless link. Various embodiments may further include receiving, sending or storing instructions and/or data implemented in

accordance with the foregoing description upon a computer-accessible medium. Generally speaking, a computer-accessible medium may include a non-transitory, computer-readable storage medium or memory medium such as magnetic or optical media, e.g., disk or DVD/CD-ROM, volatile or non-volatile media such as RAM (e.g. SDRAM, DDR, RDRAM, SRAM, etc.), ROM, etc. In some embodiments, a computer-accessible medium may include transmission media or signals such as electrical, electromagnetic, or digital signals, conveyed via a communication medium such as network and/or a wireless link.

[00429] The methods described herein may be implemented in software, hardware, or a combination thereof, in different embodiments. In addition, the order of the blocks of the methods may be changed, and various elements may be added, reordered, combined, omitted, modified, etc. Various modifications and changes may be made as would be obvious to a person skilled in the art having the benefit of this disclosure. The various embodiments described herein are meant to be illustrative and not limiting. Many variations, modifications, additions, and improvements are possible. Accordingly, plural instances may be provided for components described herein as a single instance. Boundaries between various components, operations and data stores are somewhat arbitrary, and particular operations are illustrated in the context of specific illustrative configurations. Other allocations of functionality are envisioned and may fall within the scope of claims that follow. Finally, structures and functionality presented as discrete components in the example configurations may be implemented as a combined structure or component. These and other variations, modifications, additions, and improvements may fall within the scope of embodiments as defined in the claims that follow

CLAIMS

WHAT IS CLAIMED IS:

1. A non-transitory computer-readable medium storing program instructions that, when executed by one or more processors, cause the one or more processors to:
 - determine, for a point cloud, a plurality of patches, wherein each patch comprises points of the point cloud projected on a patch plane;
 - pack attribute patch images and geometry patch images corresponding to the plurality of patches into corresponding attribute image frames and geometry image frames;
 - apply an attribute transform function to the attribute patch images of the attribute image frames to compensate for distortion or artifacts introduced during a compression and a decompression of the geometry image frames;
 - determine smoothing parameters to be applied at a smoothing filter of a decoder to smooth the geometry patch images of the geometry image frames; and
 - encode the geometry image frames and the attribute image frames that have had the attribute transform function applied, wherein the attribute transform function was applied using geometry image frames without the smoothing filter being applied to the geometry image frames.

2. The non-transitory computer-readable-medium of claim 1, wherein the smoothing parameters comprise different smoothing parameters to be applied at the decoder for different layers of the point cloud.

3. A non-transitory computer-readable medium storing program instructions that, when executed by one or more processors, cause the one or more processors to:
 - receive, at a decoder, an encoded bitstream comprising data for geometry images frames and data for attribute image frames of a point cloud, wherein the geometry image frames comprise geometry information for patches of the point cloud projected on patch planes and the attribute images frames comprise attribute information for the patches of the point cloud projected on the patch planes;

decode the encoded bitstream;
reconstruct geometry patches and attribute patches for the point cloud using decoded geometry image frames and decoded attribute image frames, decoded from the encoded bitstream;
apply a smoothing filter to:
 geometry patches of the geometry image frames; or
 a reconstructed version of the point cloud generated using the geometry patches of the geometry image frames;
determine parameters for an attribute transfer function to be applied to the attribute patches to compensate for changes in geometry due to the application of the smoothing filter; and
apply the attribute transfer function to attribute values of the attribute patches to compensate for the changes in geometry of the smoothed geometry patches or the smoothed reconstructed version of the point cloud, wherein the changes in geometry are relative to respective geometries of the geometry patches of the geometry images prior to applying the smoothing filter.

4. The non-transitory computer-readable medium of claim 3, wherein the program instructions, further cause the one or more processors to:

 apply an attribute smoothing filter to the attribute values of the attribute patches, wherein the attribute smoothing filter is applied in combination with applying the attribute transfer function.

5. The non-transitory computer-readable medium of claim 3, wherein the smoothing filter is selected by a user or a designer of the decoder.

6. The non-transitory computer-readable medium of claim 3, wherein:

 the encoded bit-stream comprises smoothing parameters to be applied at the decoder,
 and

 the smoothing filter applied to the geometry patches or the reconstructed version of the point cloud is selected or adjusted at the decoder based, at least in part, on the smoothing parameters signaled in the bitstream.

7. The non-transitory computer-readable medium of claim 3, wherein the smoothing filter used by the decoder is a non-normative smoothing filter with regard to a compression standard used to compress and decompress the point cloud.

8. The non-transitory computer-readable medium of claim 3, wherein the program instructions further cause the one or more processors to:

select the smoothing filter to be applied at the decoder from a plurality of smoothing filters supported by the decoder based on an operation mode of a device comprising the decoder or based on a smoothing parameter signaled in the bitstream.

9. The non-transitory computer-readable medium of claim 8, wherein the program instructions cause the one or more processors to:

select a first smoothing filter if the device comprising the decoder is connected to an external power source; and

select a second smoothing filter type if the device comprising the decoder is receiving power from a battery of the device.

10. The non-transitory computer-readable medium of claim 3, wherein the program instructions, cause the one or more processors to:

perform said apply the smoothing filter, said determine parameters for the attribute transfer function, and said apply the attribute transfer function on a point-by-point basis in parallel for a plurality of points of the point cloud.

11. The non-transitory computer-readable medium of claim 3, wherein the program instructions, cause the one or more processors to:

perform said apply the smoothing filter, said determine parameters for the attribute transfer function, and said apply the attribute transfer function as serial operations performed in series for a set of points of the point cloud.

12. The non-transitory computer-readable medium of claim 3, wherein the program instructions, cause the one or more processors to:

perform said apply the smoothing filter, said determine parameters for the attribute transfer function, and said apply the attribute transfer function in a 2D domain on the geometry patch images and the attribute patch images for the point cloud.

13. The non-transitory computer-readable medium of claim 3, wherein the program instructions, cause the one or more processors to:

perform said apply the smoothing filter, said determine parameters for the attribute transfer function, and said apply the attribute transfer function in a 3D domain on the reconstructed version of the point cloud comprising a reconstructed geometry of the point cloud.

14. The non-transitory computer-readable medium of claim 3, wherein the program instructions, cause the one or more processors to:

perform said apply the smoothing filter, said determine parameters for the attribute transfer function, and said apply the attribute transfer function as part of a rendering process for rendering the reconstructed version of the point cloud.

15. The non-transitory computer-readable medium of claim 3, wherein the program instructions cause the one or more processors to:

determine one or more layers of a plurality of layers of the point cloud to reconstruct;
and

perform said apply the smoothing filter, said determine parameters for the attribute transfer function, and said apply the attribute transfer function only on the one or more layers determined to be reconstructed.

16. The non-transitory computer-readable medium of claim 3, wherein the program instructions, cause the one or more processors to:

recursively perform said apply the smoothing filter, said determine parameters for the attribute transfer function, and said apply the attribute for two or more iterations.

17. The non-transitory computer-readable medium of claim 3, wherein the program instructions cause the one or more processors to:

determine one or more views at which the reconstructed version of the point cloud will be viewed; and
perform said apply the smoothing filter, said determine parameters for the attribute transfer function, and said apply the attribute transfer function only on portions of the point cloud viewable in the one or more views.

18. A device, comprising:

a memory storing program instructions; and

one or more processors, wherein the program instructions, when executed by one or more processors, cause the one or more processors to:

receive a bitstream comprising data for geometry images frames and attribute image frames of a point cloud, wherein the geometry image frames comprise geometry information for patches of the point cloud projected onto patch planes and the attribute images frames comprise attribute information for the patches of the point cloud projected onto the patch planes;

reconstruct geometry patches and attribute patches for the point cloud using geometry image frames and attribute image frames included in the bitstream;

apply a smoothing filter to geometry patches of the geometry image frames or a reconstructed geometry of the point cloud generated using the geometry patches of the geometry image frames;

determine parameters for an attribute transfer function to compensate for changes in geometry due to the application of the smoothing filter; and

apply an attribute transfer function to attribute values reconstructed from the attribute patches of the attribute image frames to compensate for the changes in geometry of the smoothed geometry patches or the smoothed reconstructed geometry relative to respective geometries of the geometry patches of the geometry images prior to applying the smoothing filter.

19. The device of claim 18, wherein the smoothing filter is a non-normative smoothing filter selected by a designer of the device.

20. The device of claim 18, wherein the program instructions, further cause the one or more processors to:

apply an attribute smoothing filter to the attribute values of the attribute patches, wherein the attribute smoothing filter is applied in combination with applying the attribute transfer function.

21. The device of claim 18, wherein said apply the smoothing filter, said determine parameters for the attribute transfer function, and said apply the attribute transfer function are performed as part of a post-processing step subsequent to decompression of the geometry image frames and attribute image frames or subsequent to reconstruction of a reconstructed version of the point cloud.

22. The device of claim 18, wherein:

the encoded bit-stream comprises data indicated different smoothing parameters for different layers of the point cloud; and

the smoothing filter applied to the geometry patches or the reconstructed geometry is selected or adjusted based, at least in part, on data included in the bitstream indicating different smoothing parameters to be applied to different layers of the point cloud.

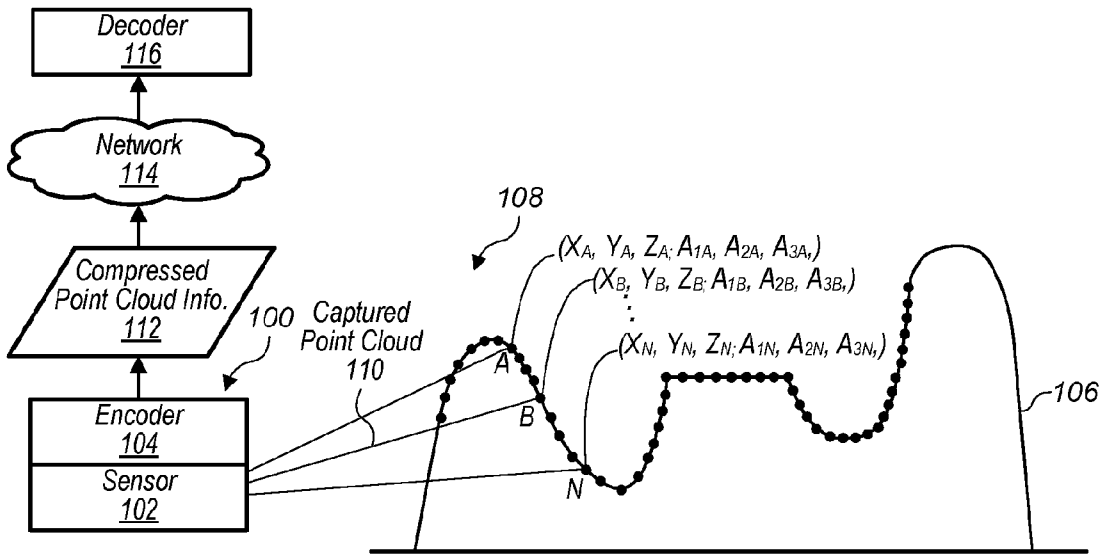

FIG. 1

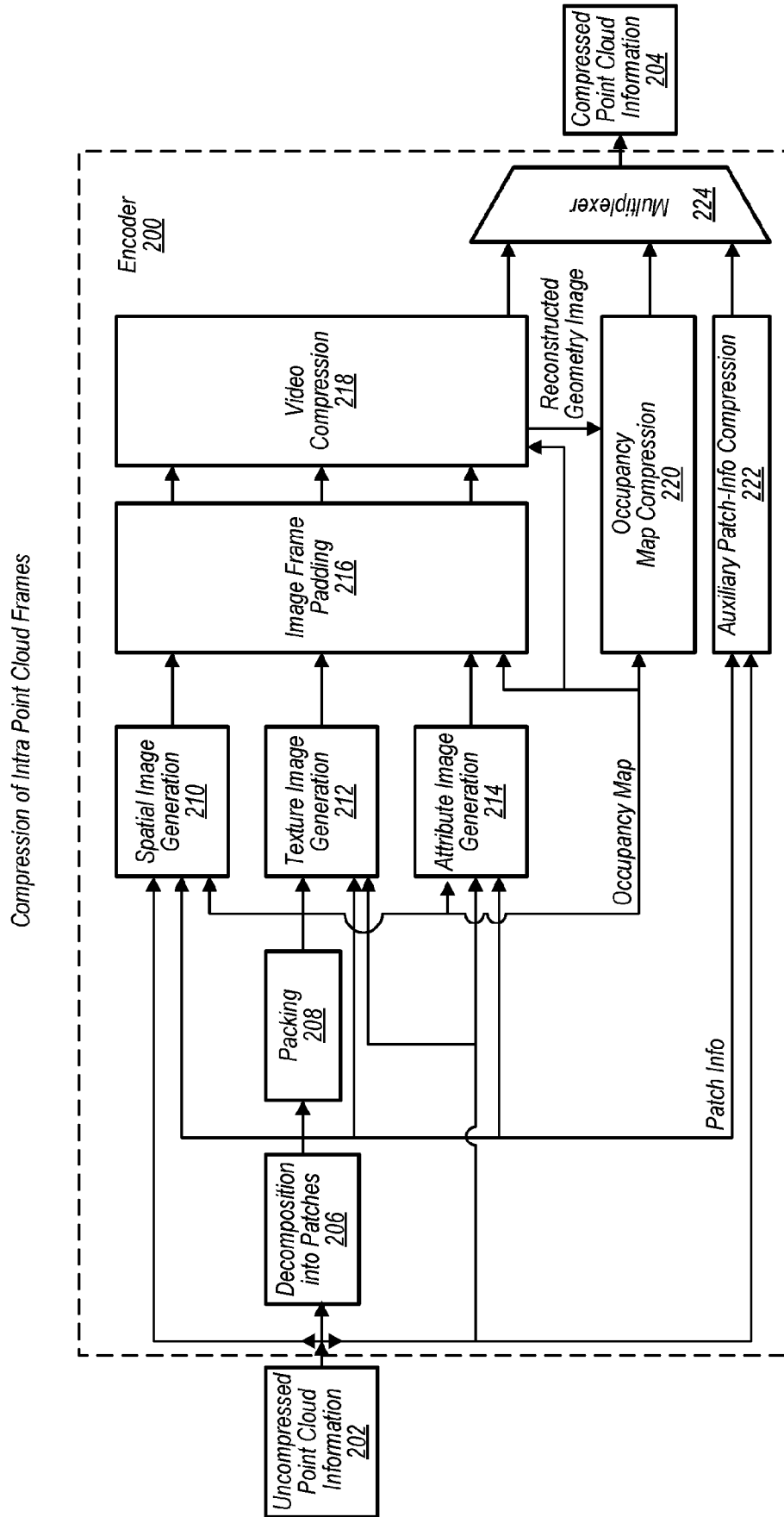

FIG. 2A

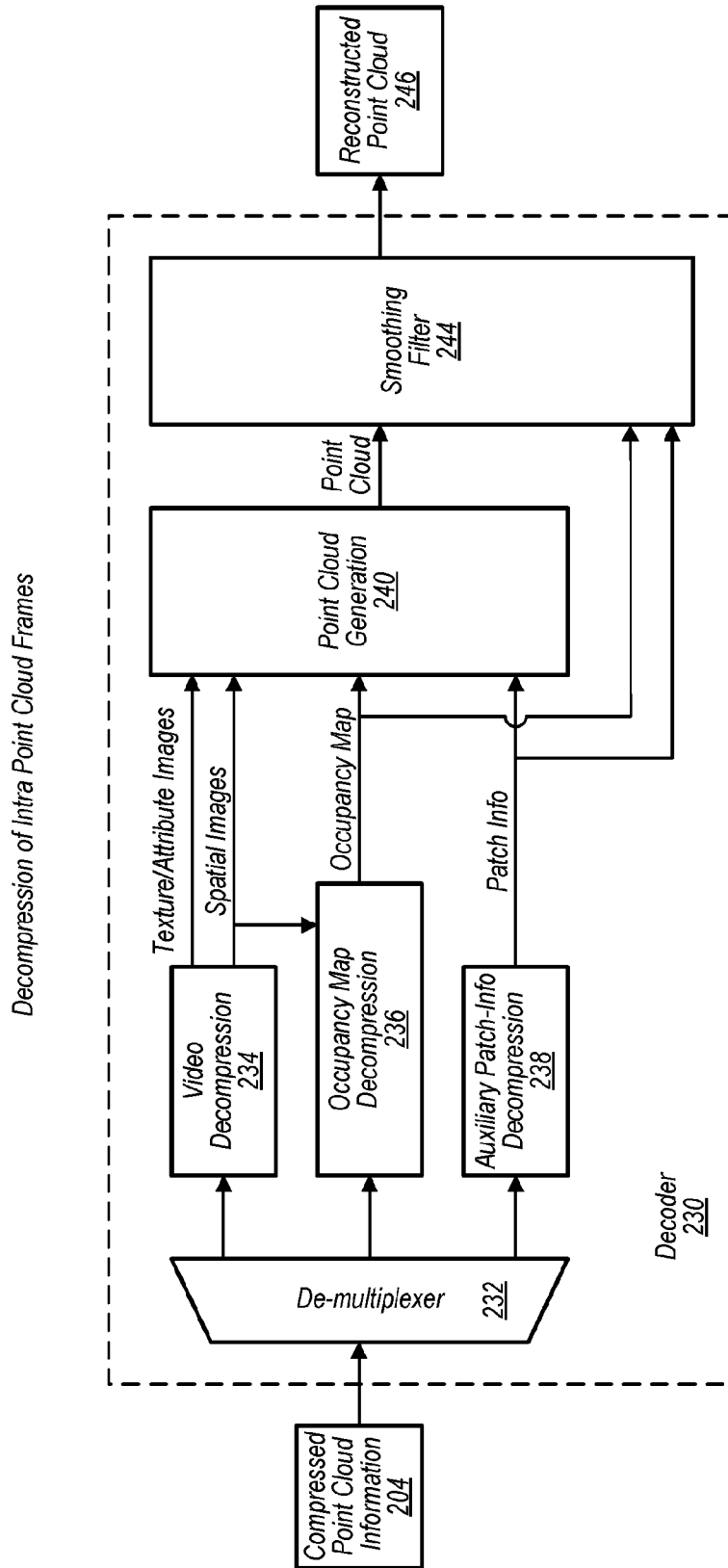

FIG. 2B

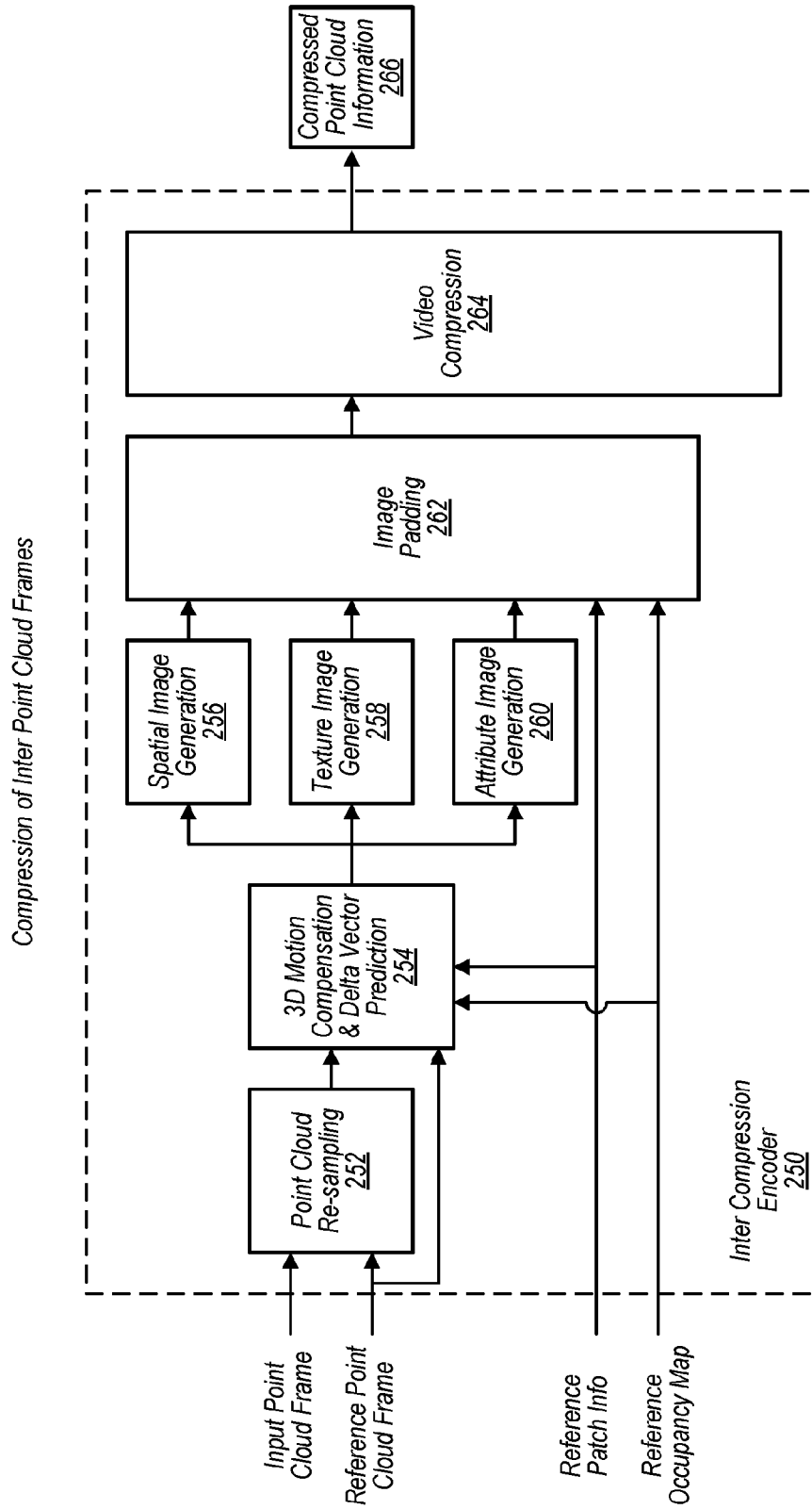

FIG. 2C

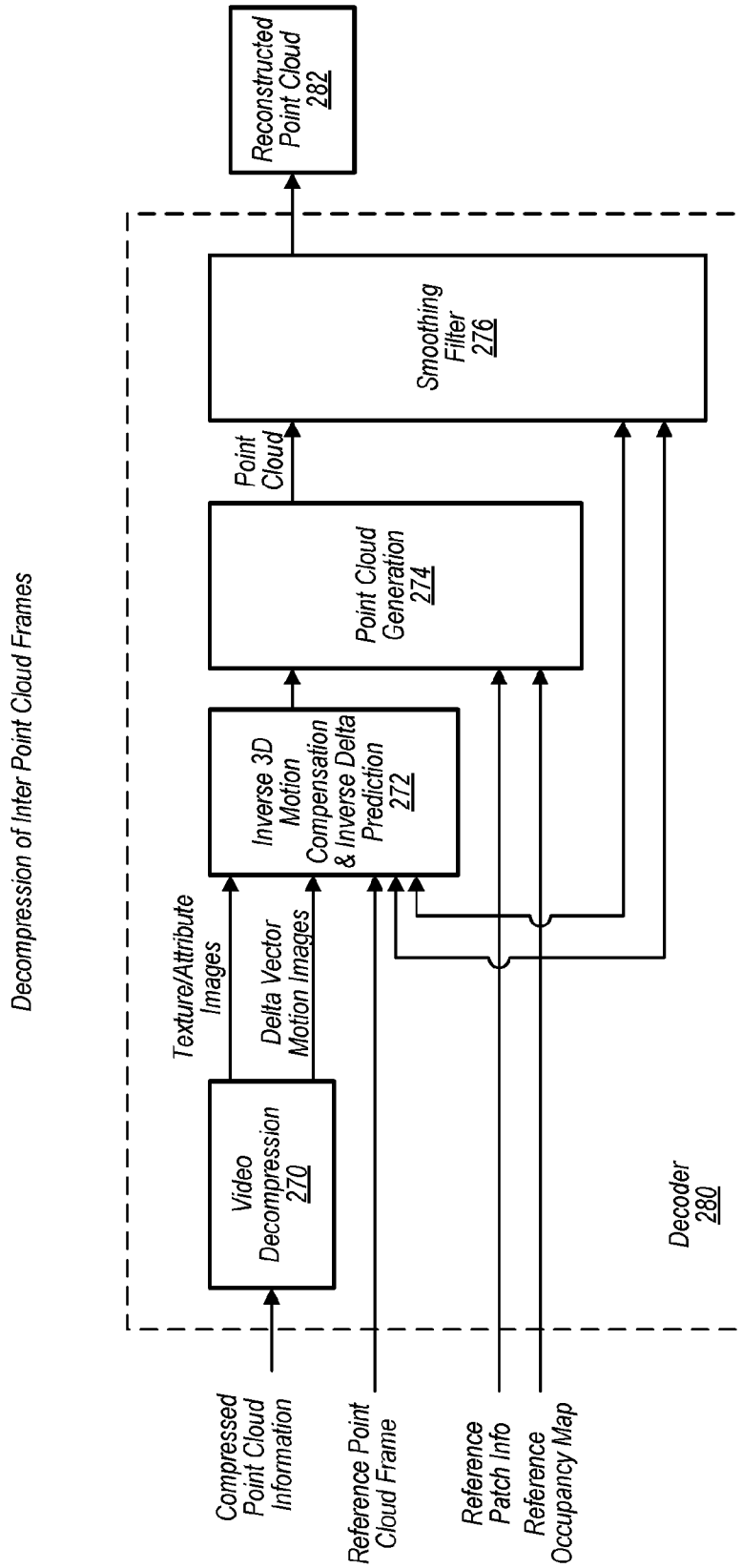

FIG. 2D

6/45

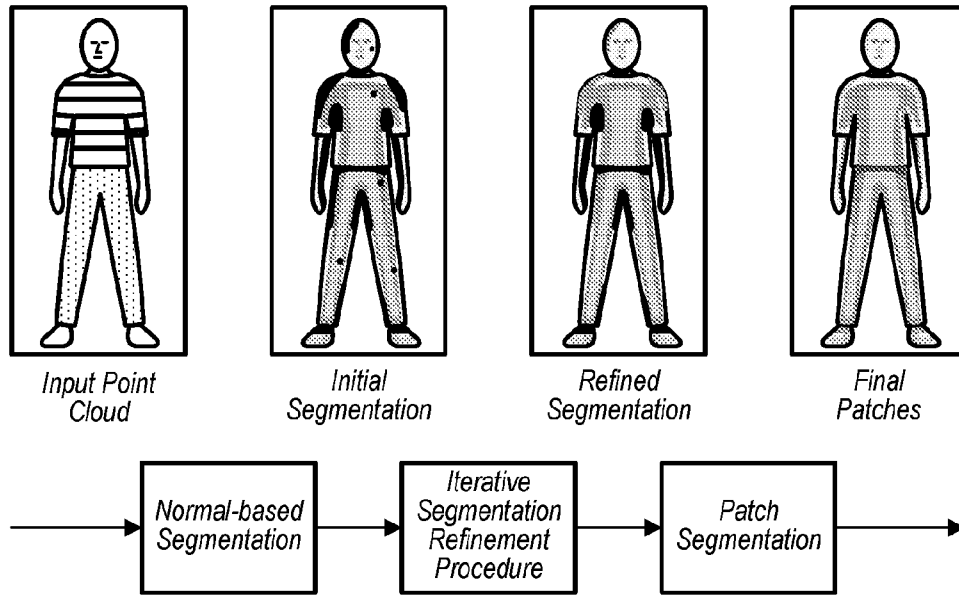

FIG. 3A

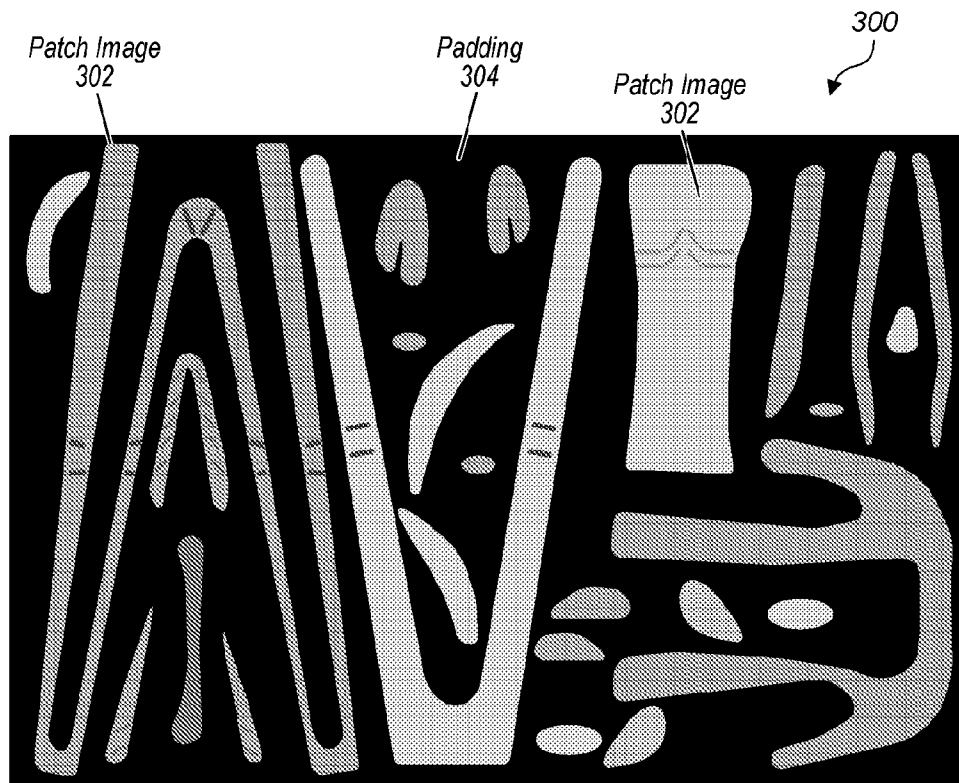

FIG. 3B

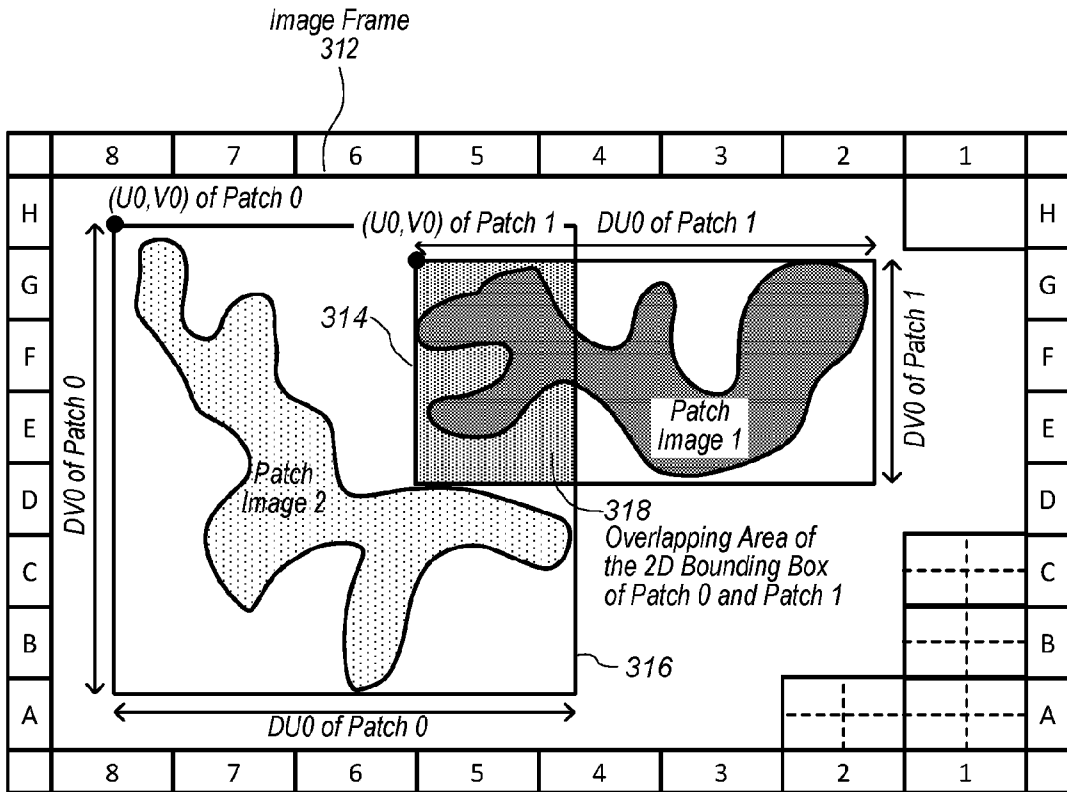

FIG. 3C

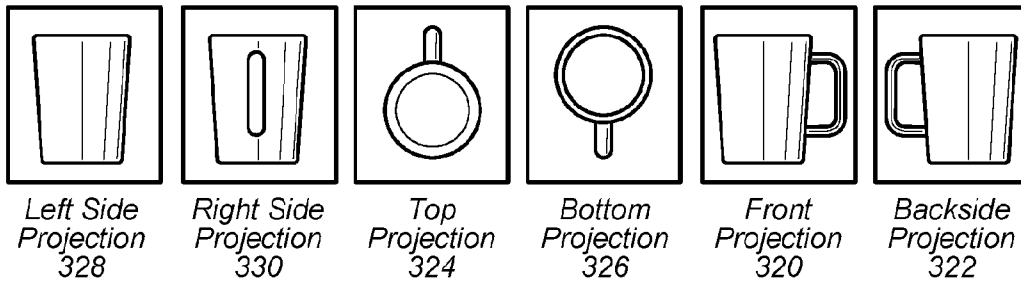

FIG. 3D

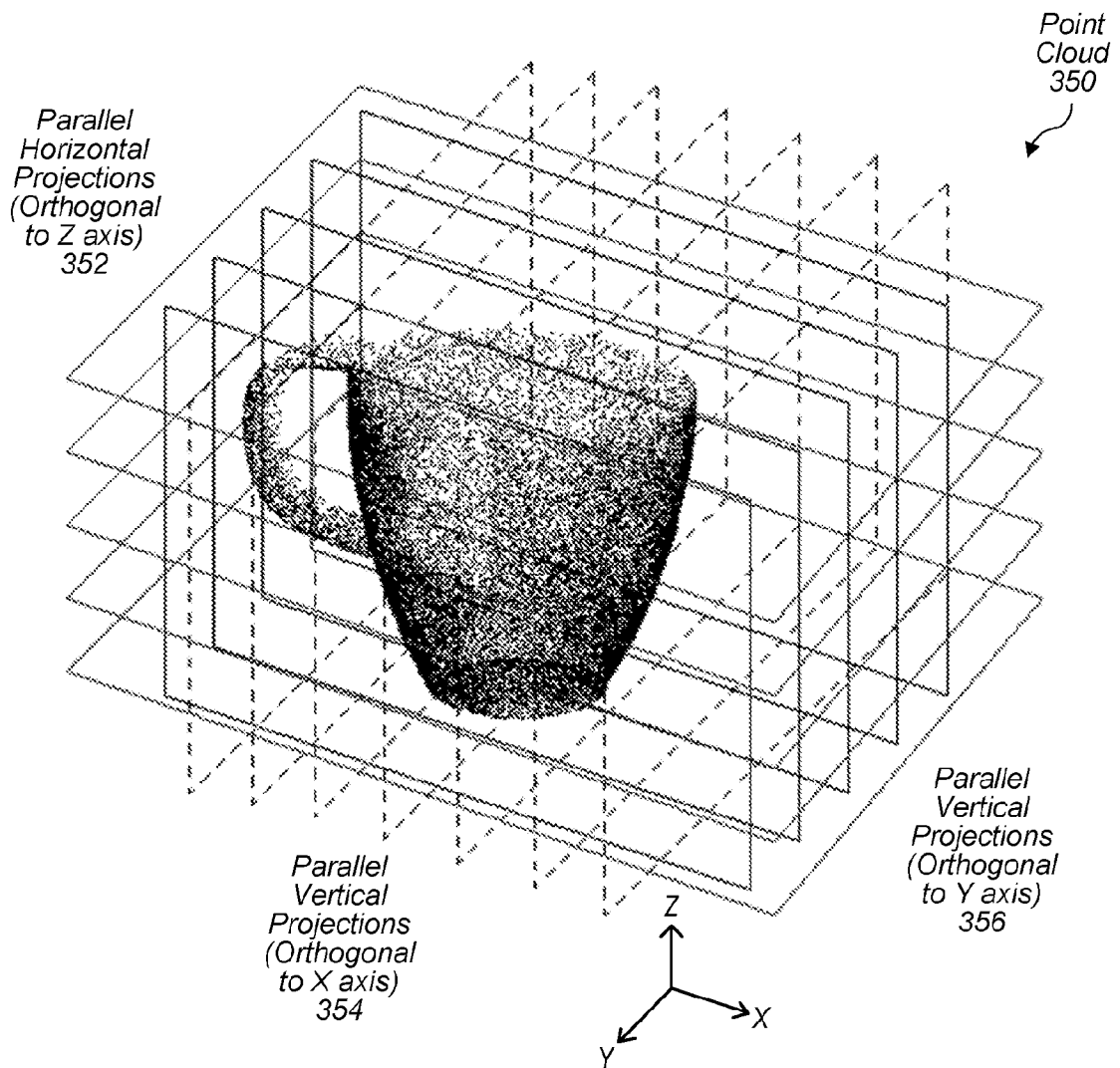

FIG. 3E

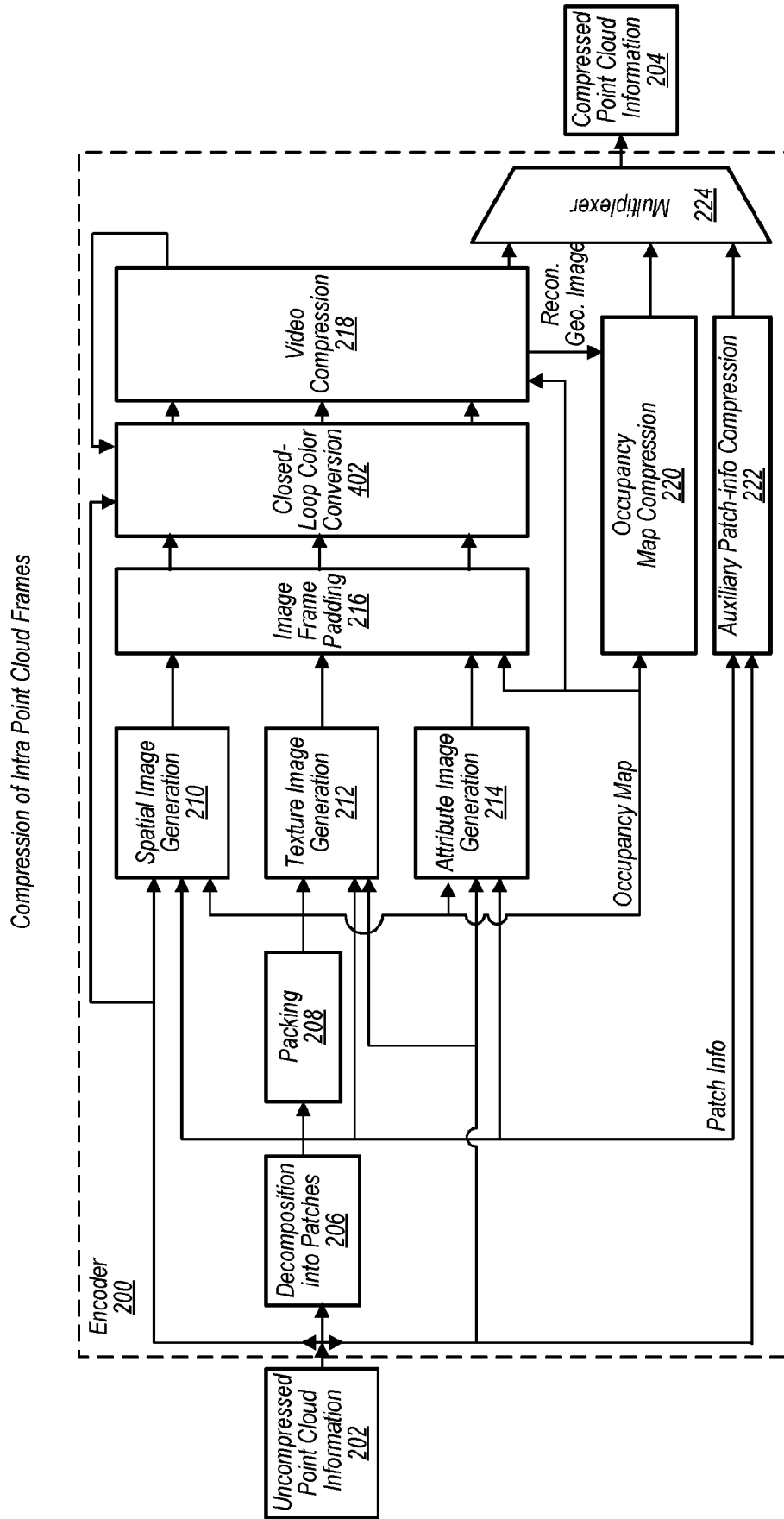

FIG. 4A

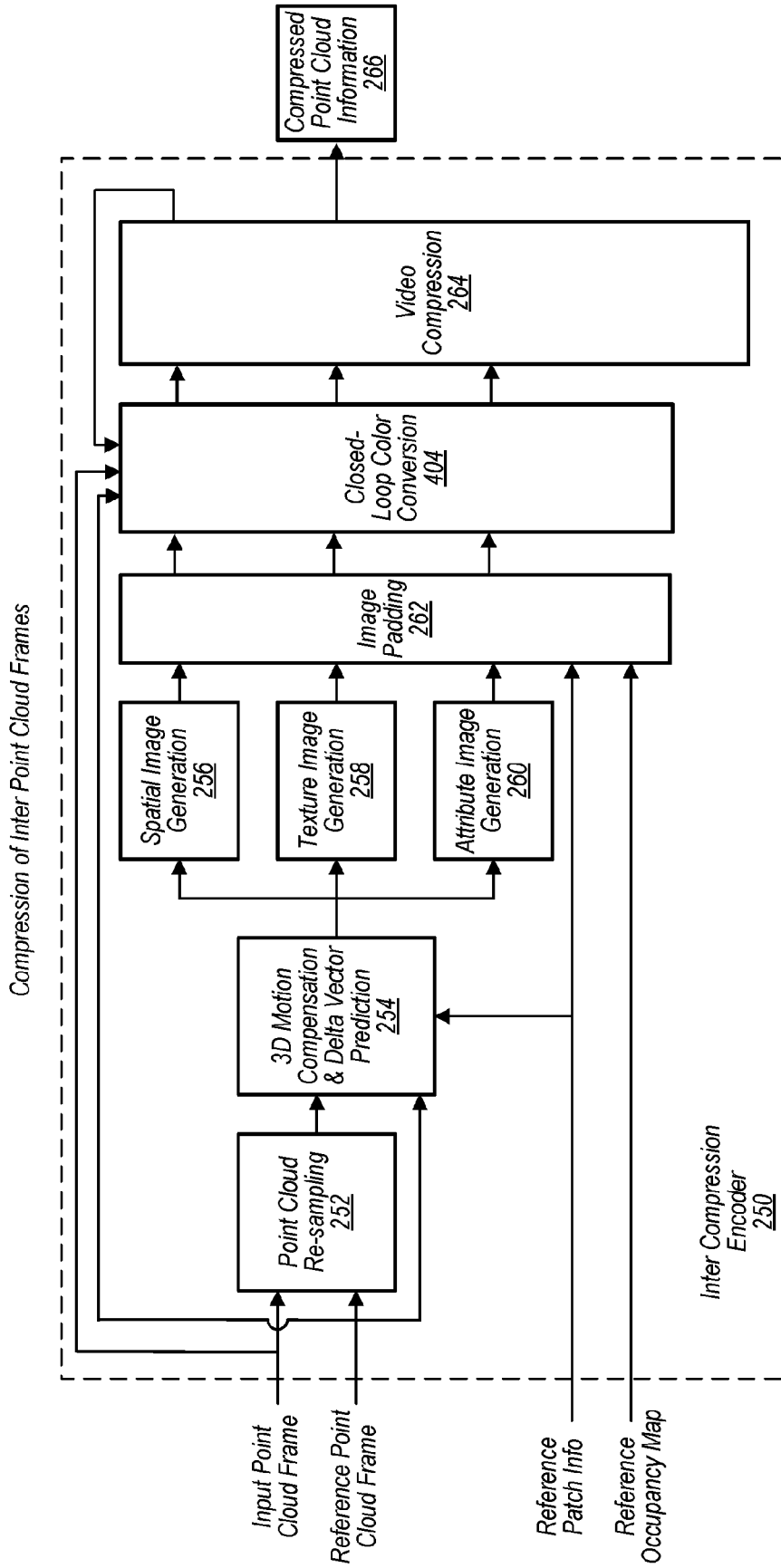

FIG. 4B

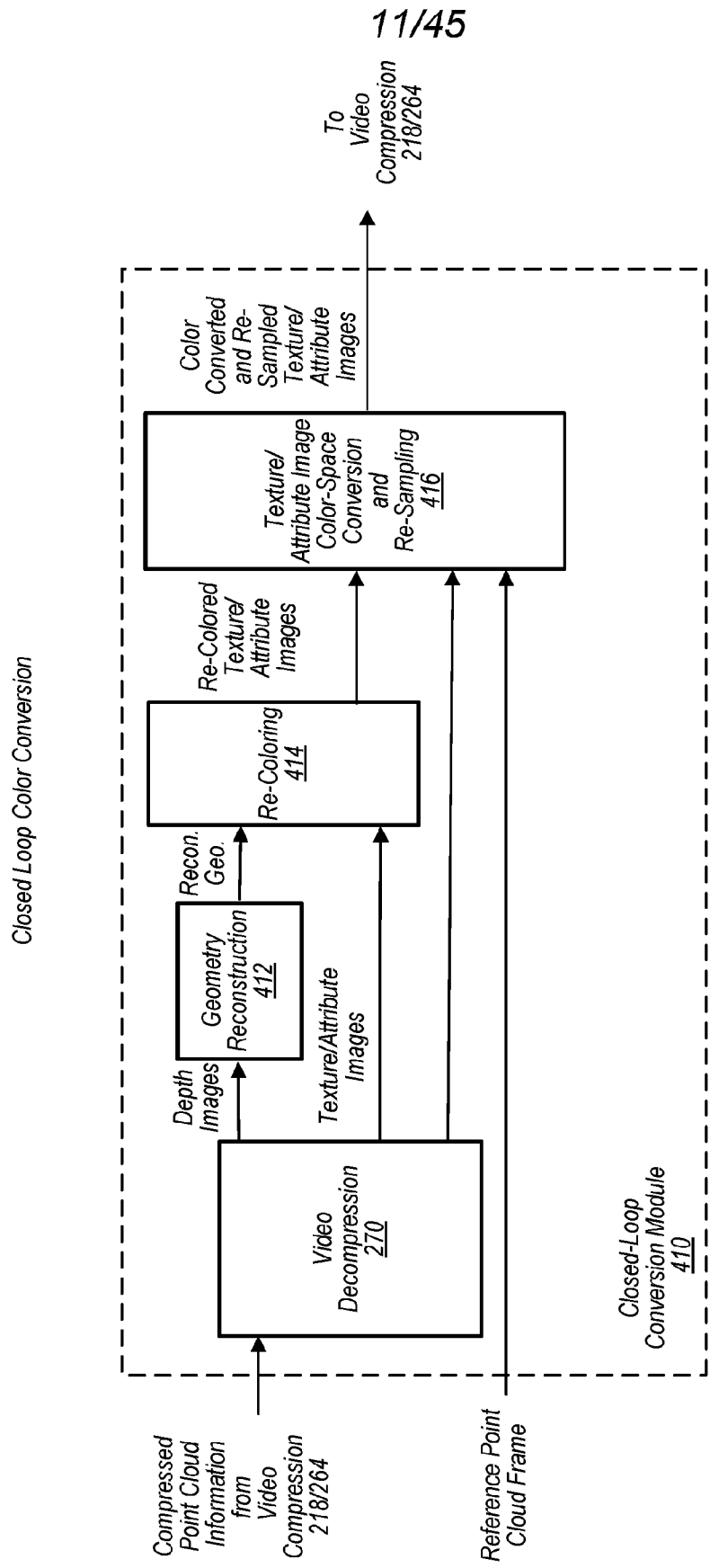

FIG. 4C

12/45

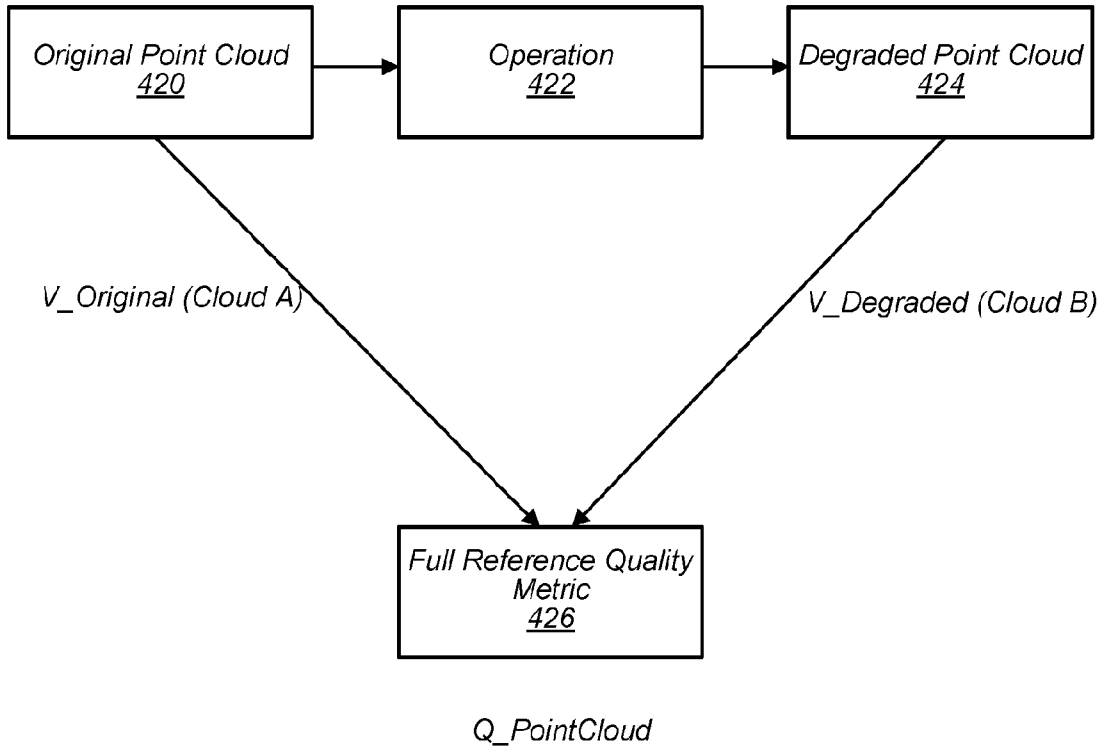

FIG. 4D

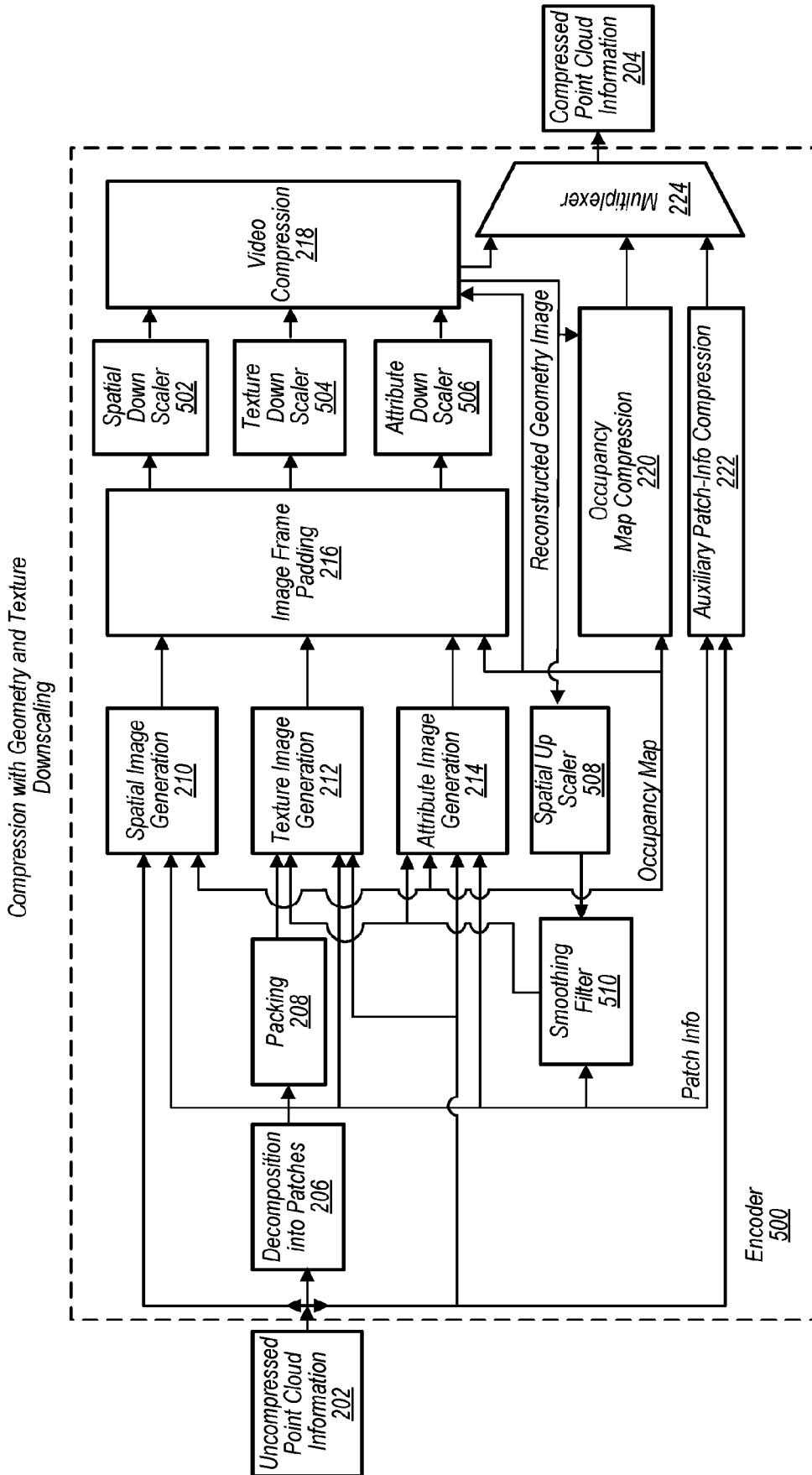

FIG. 5A

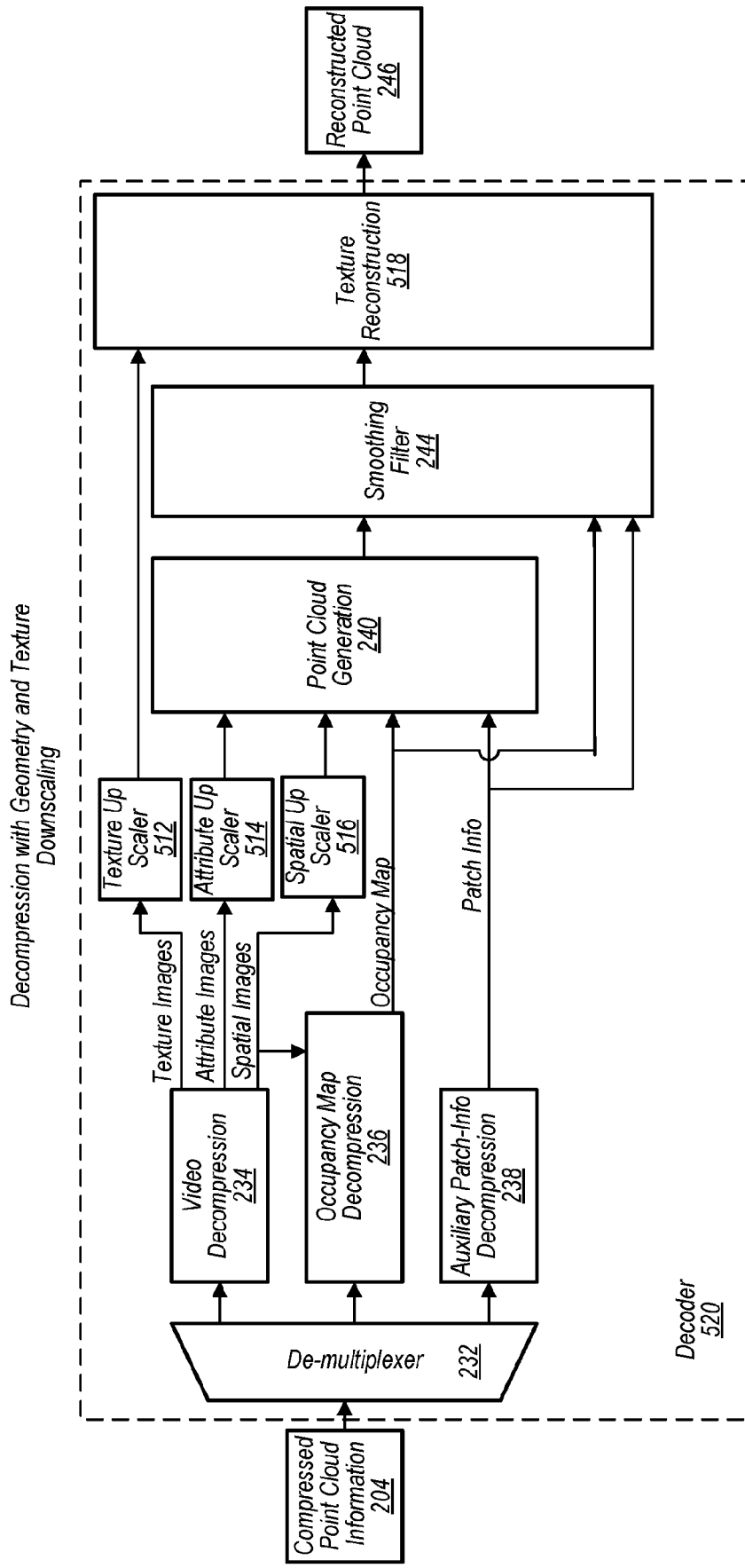

FIG. 5B

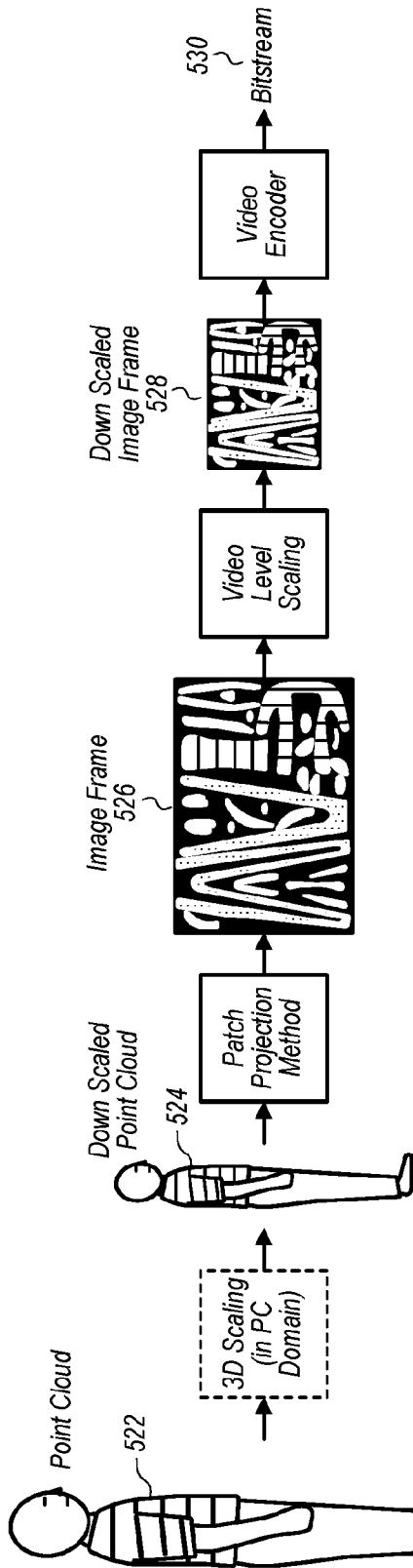

FIG. 5C

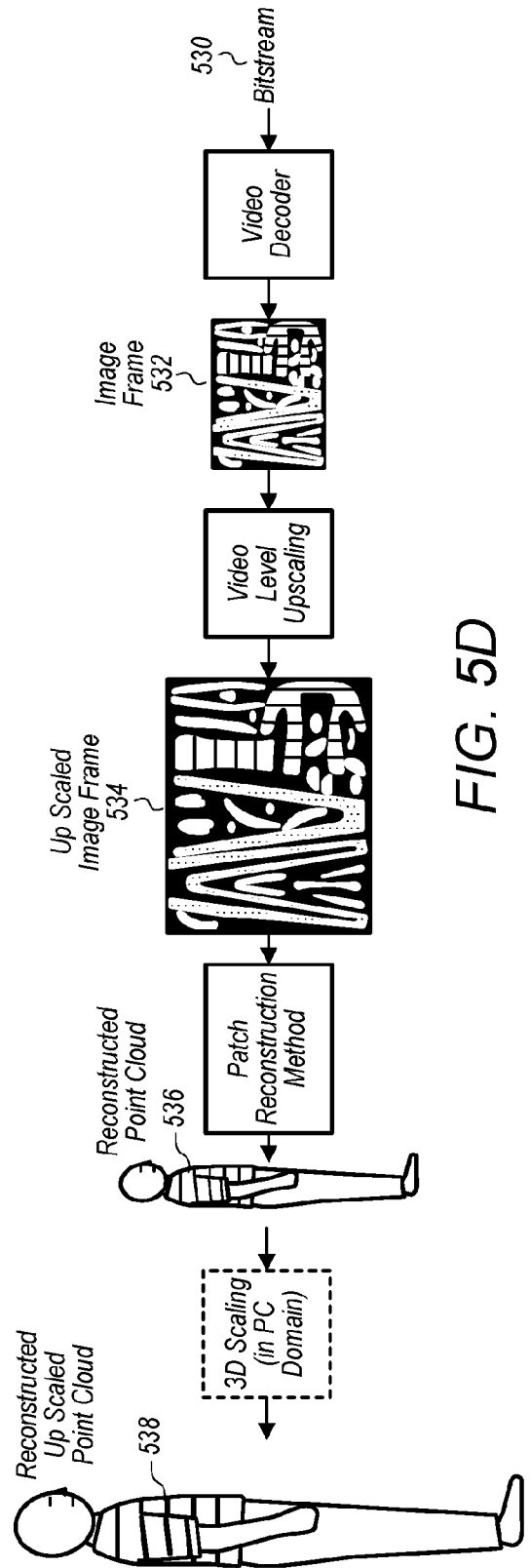

FIG. 5D

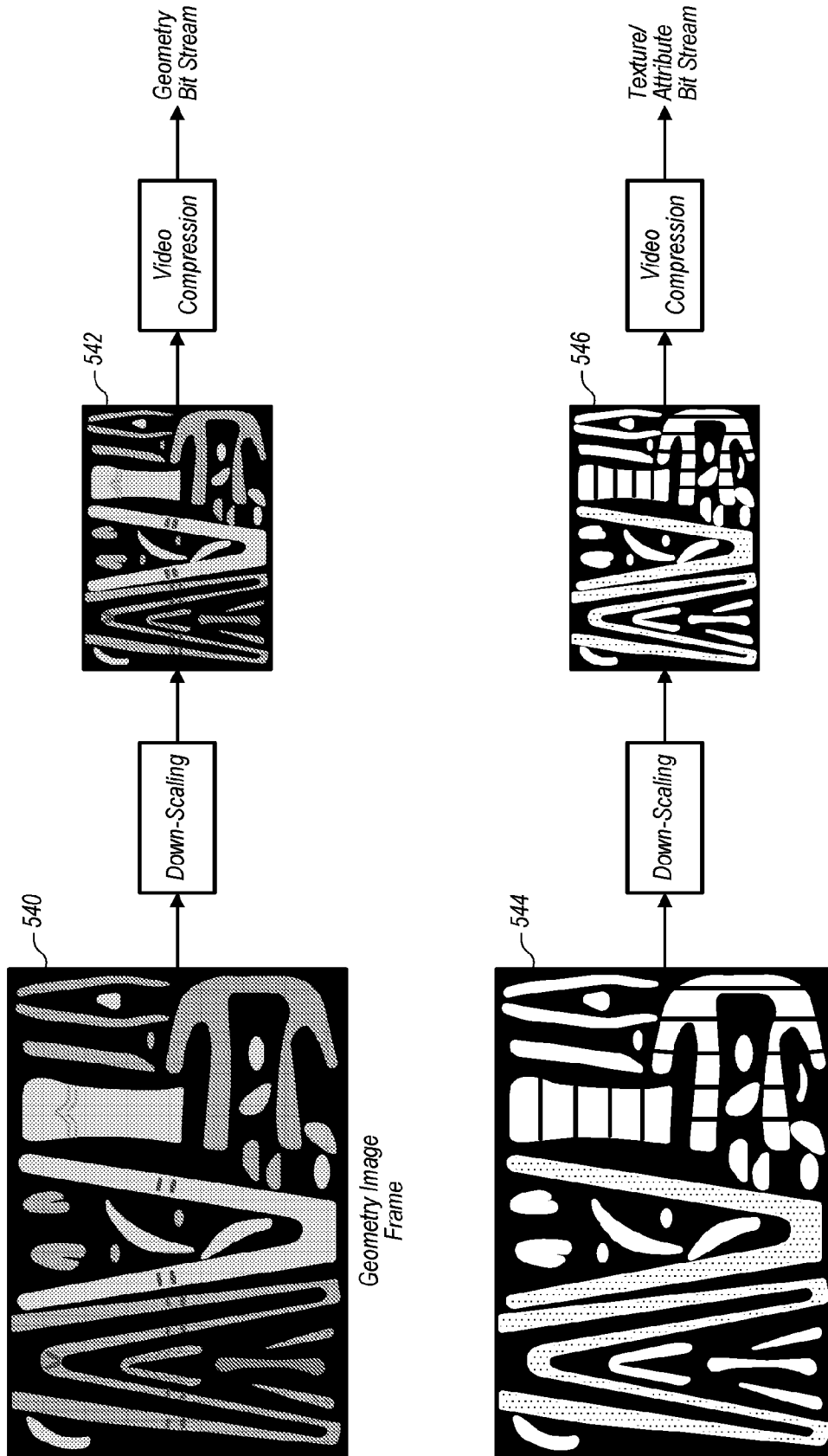

FIG. 5E

Texture/Attribute Image Frame

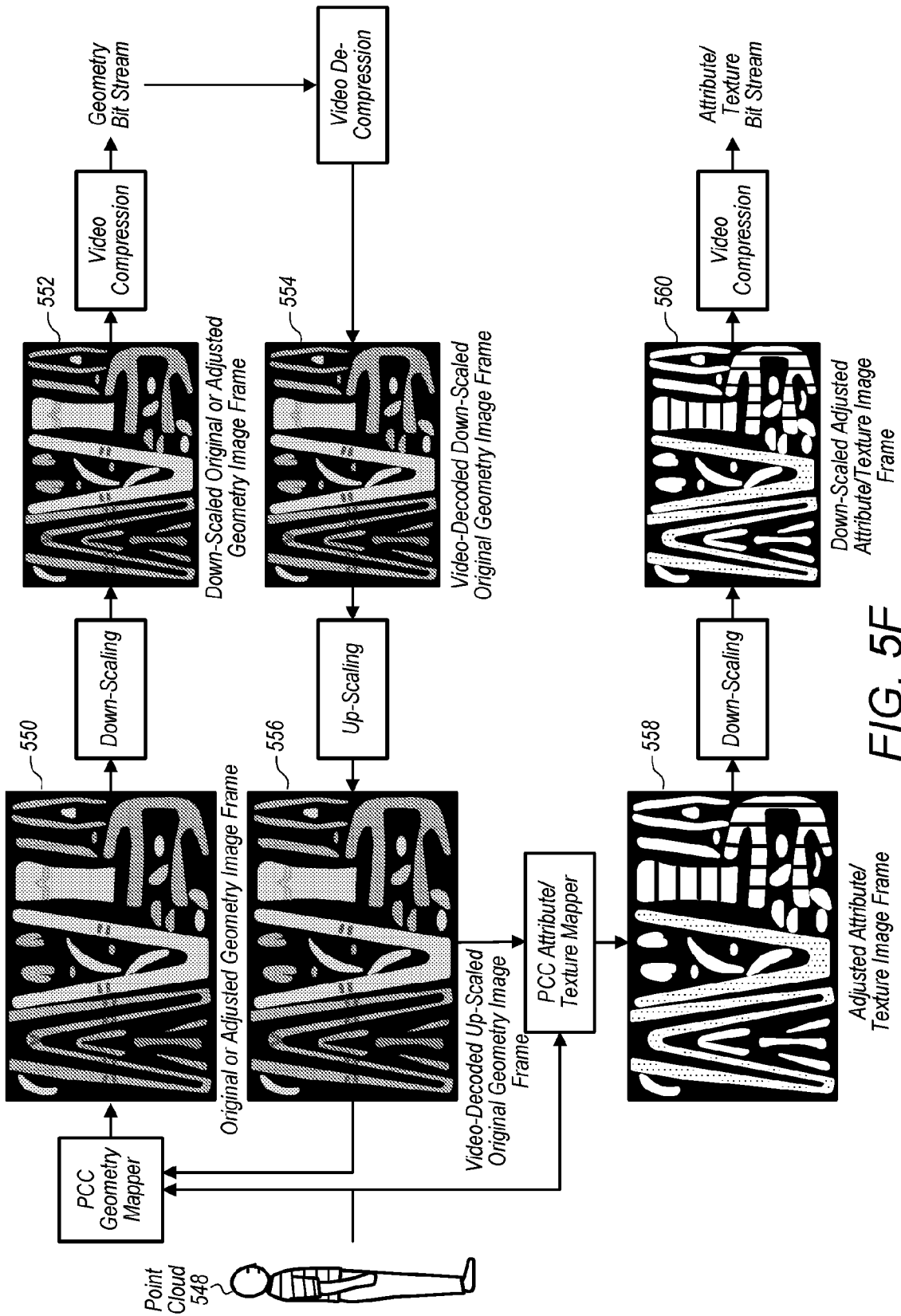

FIG. 5F

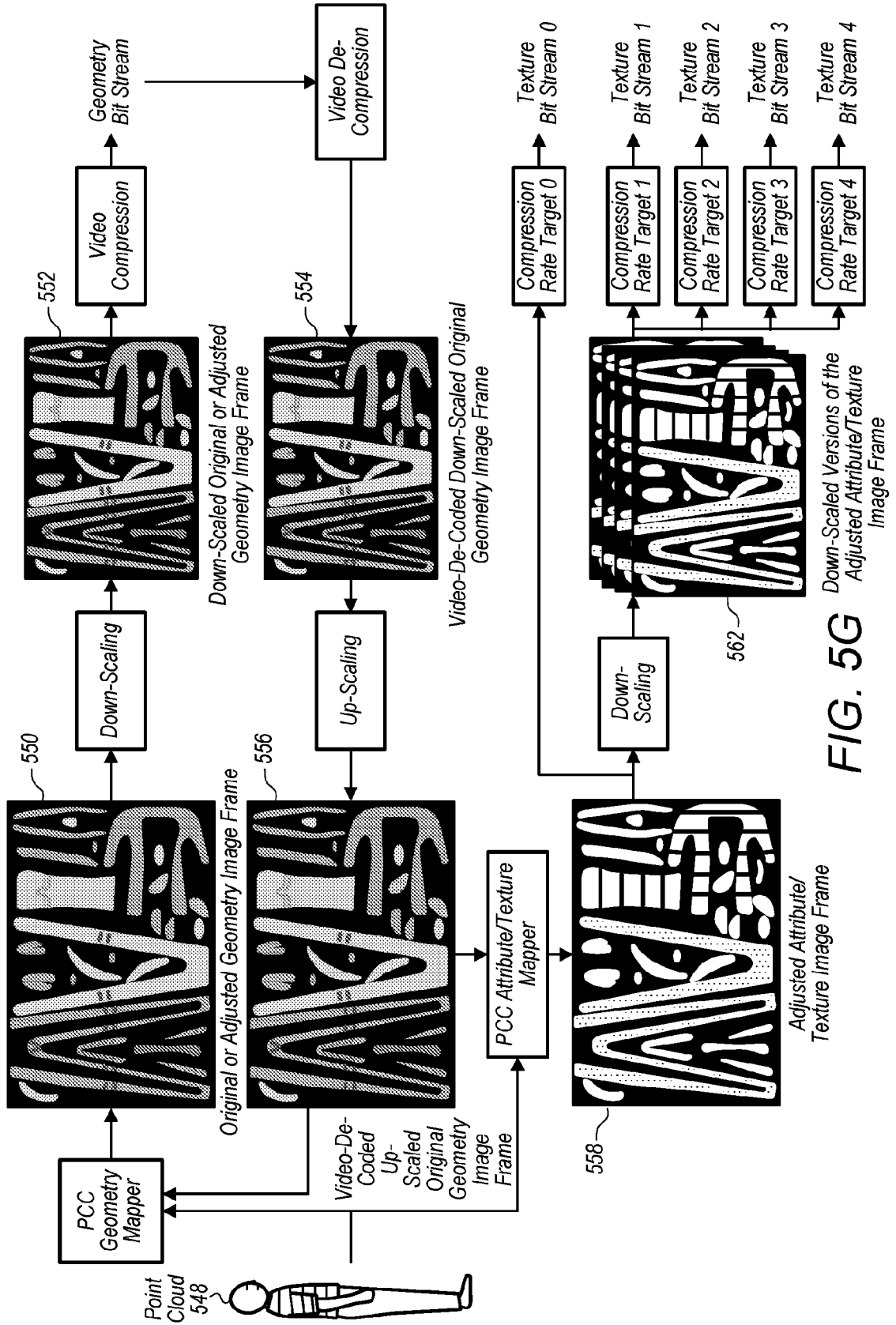

FIG. 5G

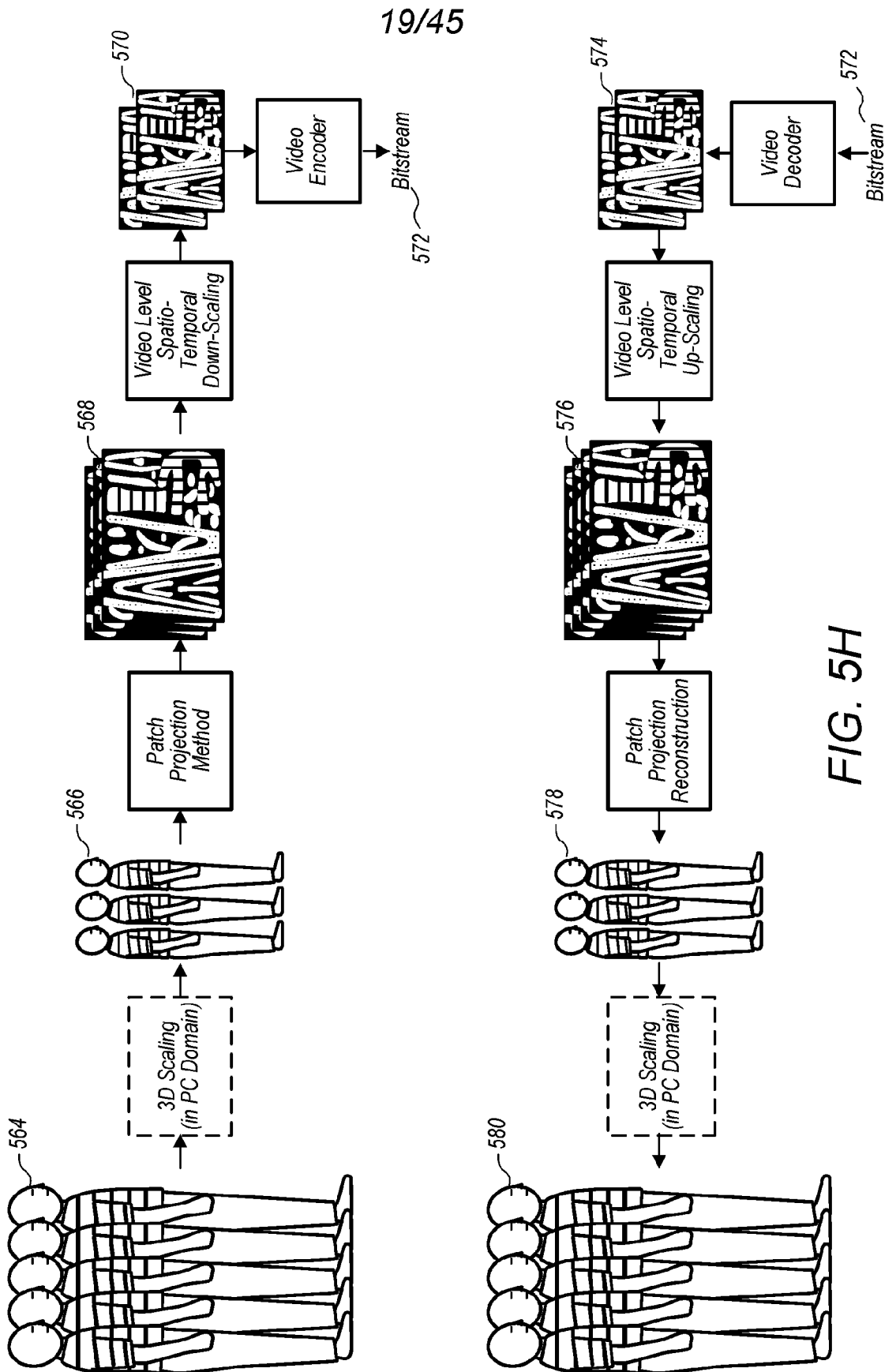

FIG. 5H

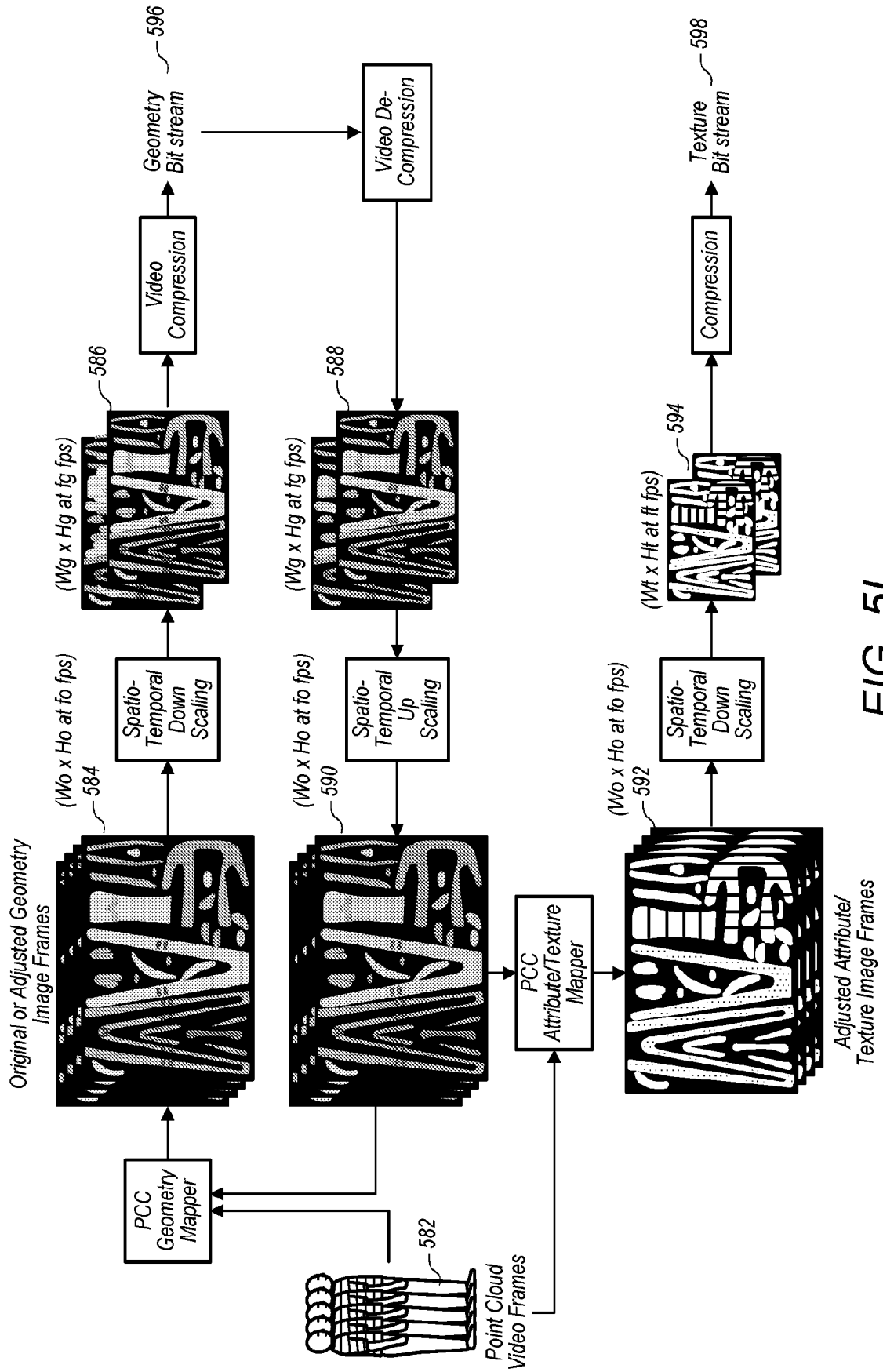

FIG. 5I

21/45

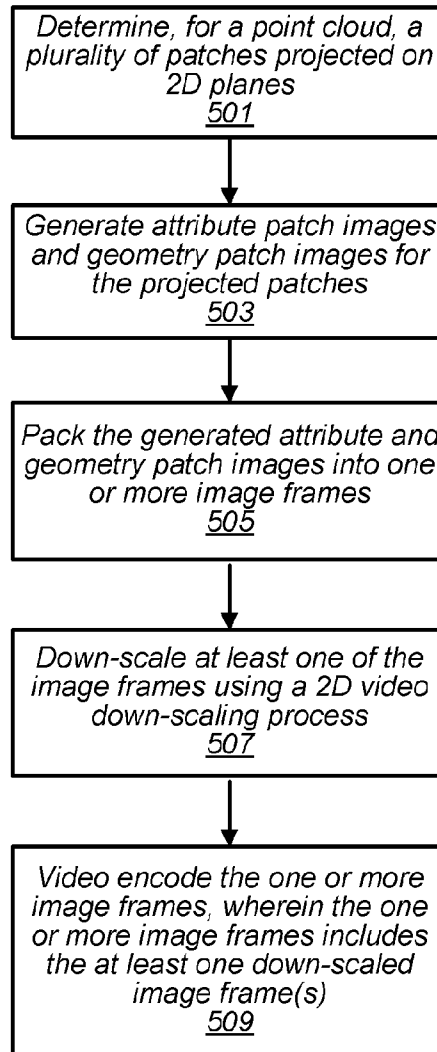

FIG. 5J

22/45

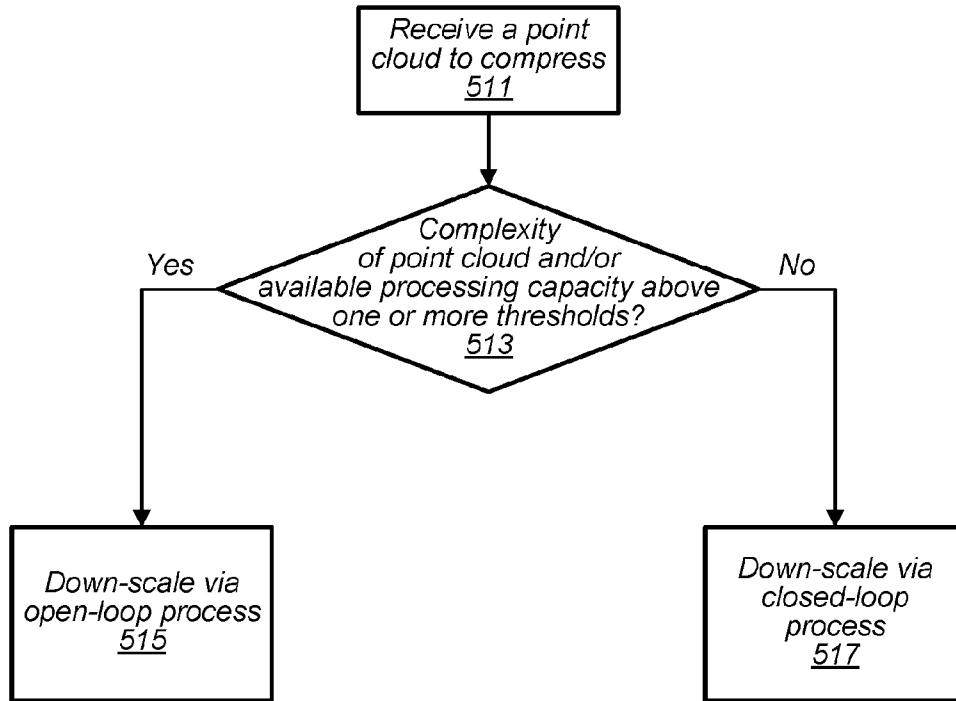

FIG. 5K

23/45

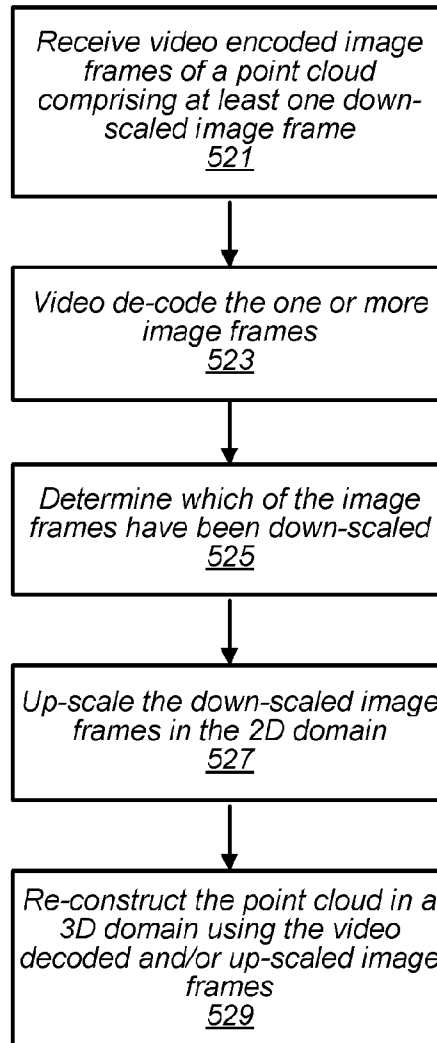

FIG. 5L

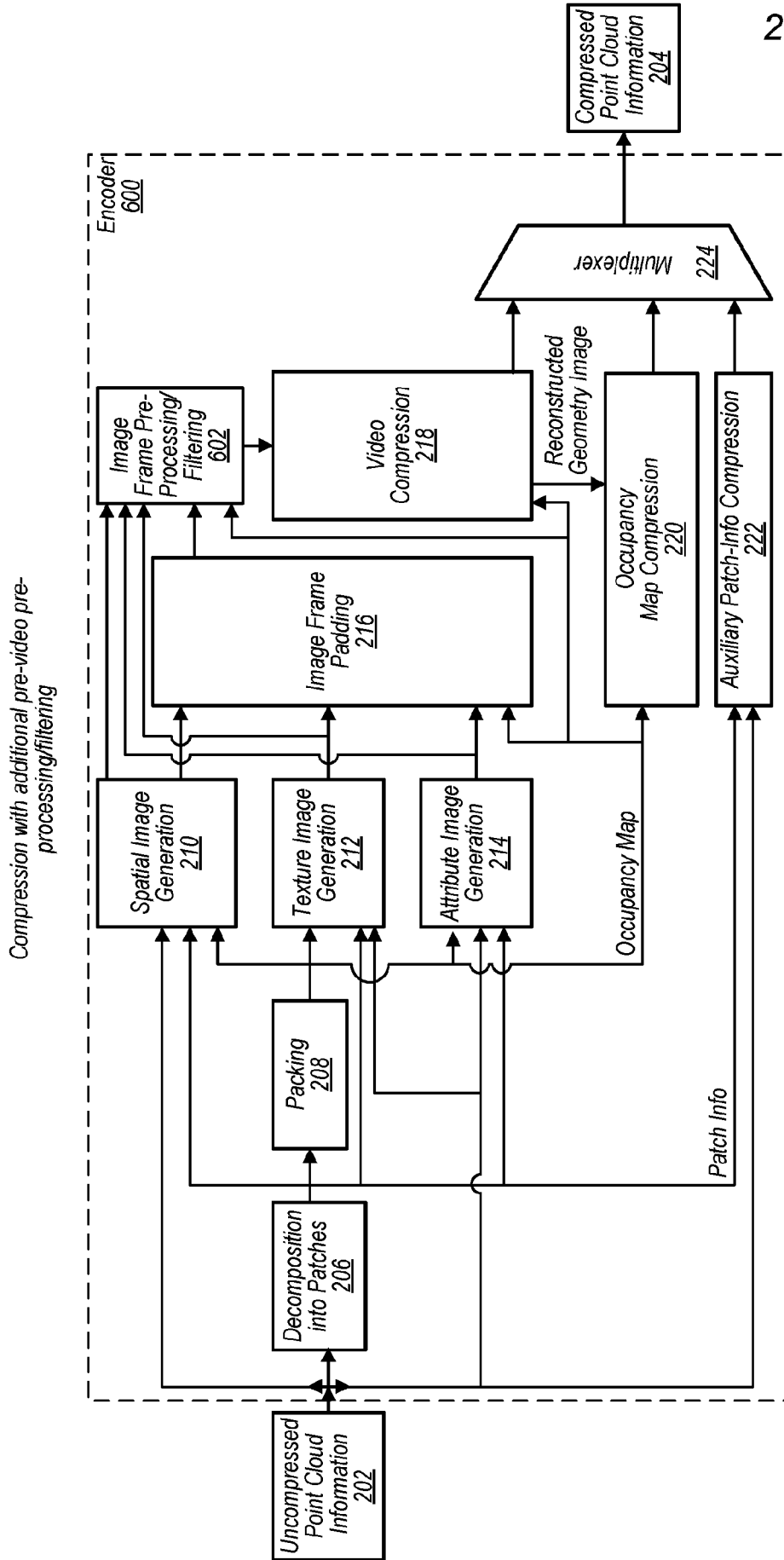

FIG. 6A

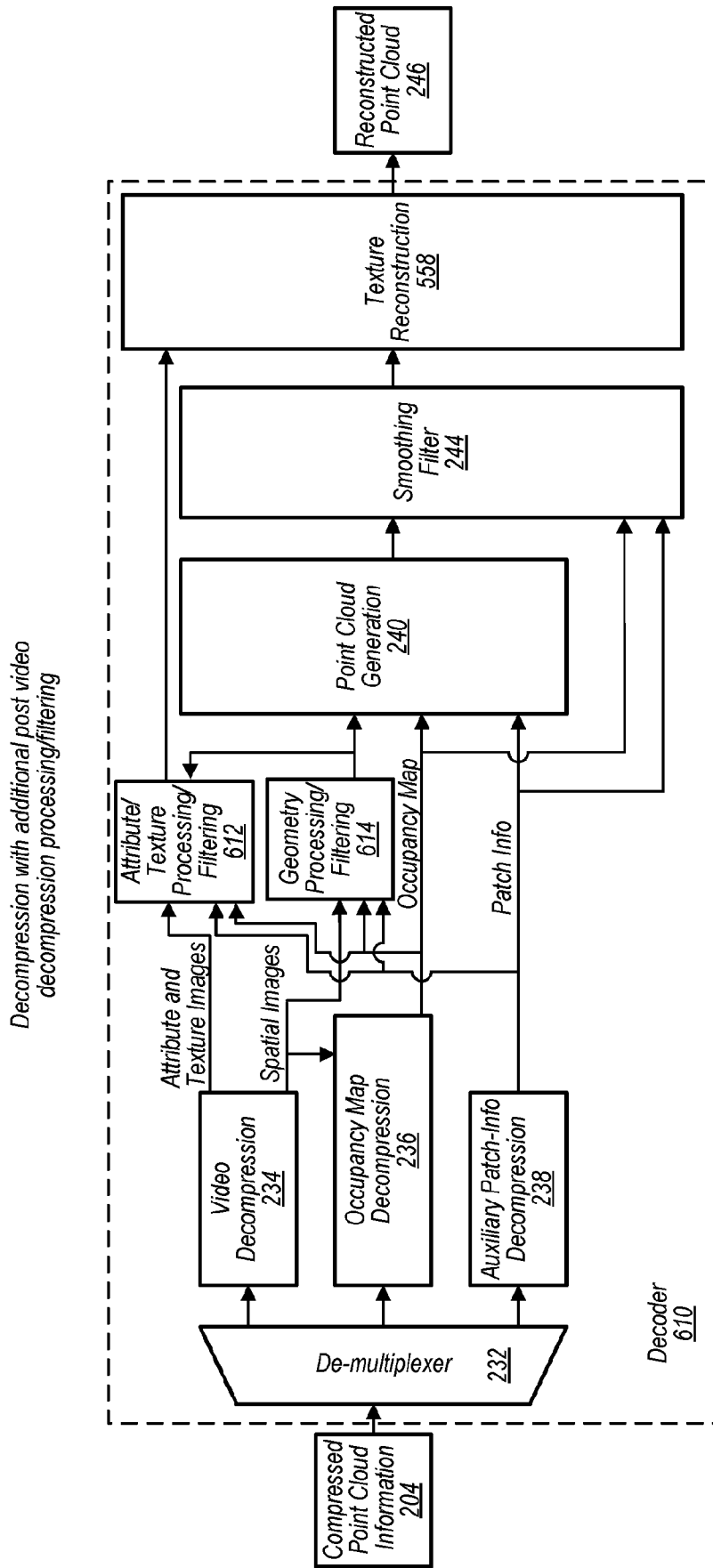

FIG. 6B

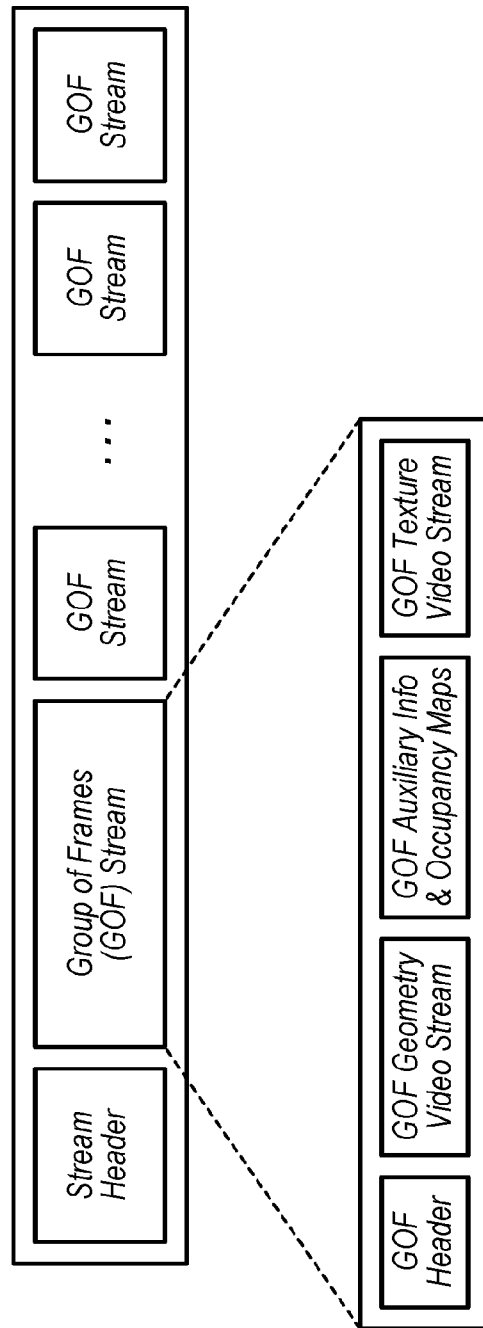

FIG. 6C

27/45

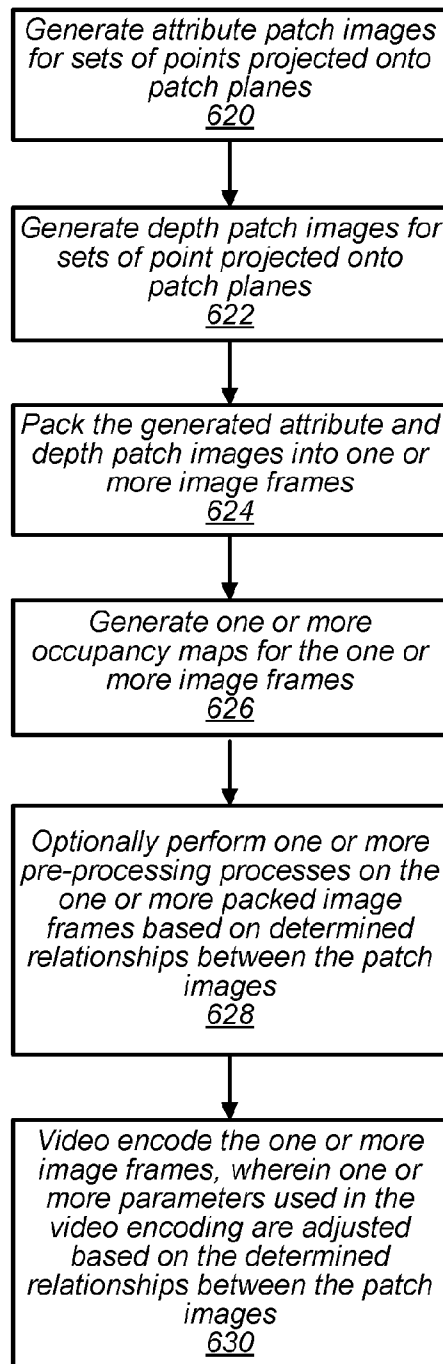

FIG. 6D

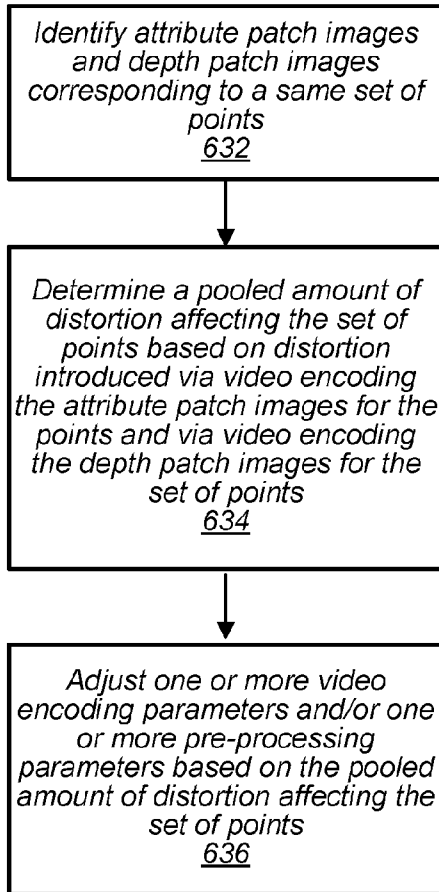

FIG. 6E

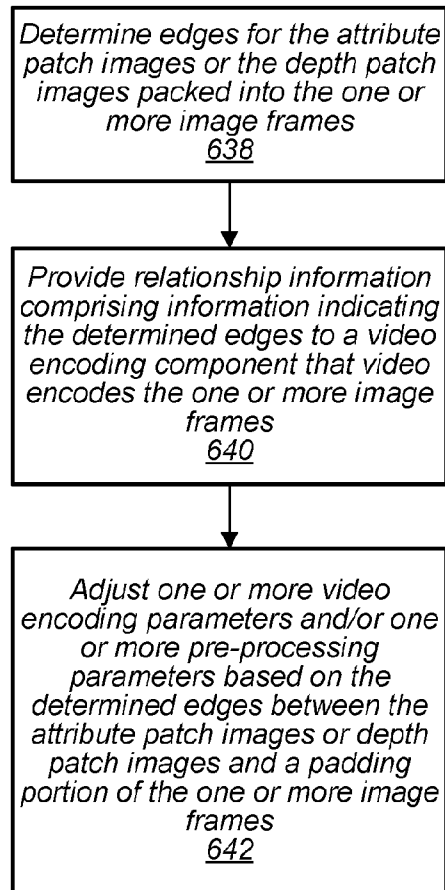

FIG. 6F

29/45

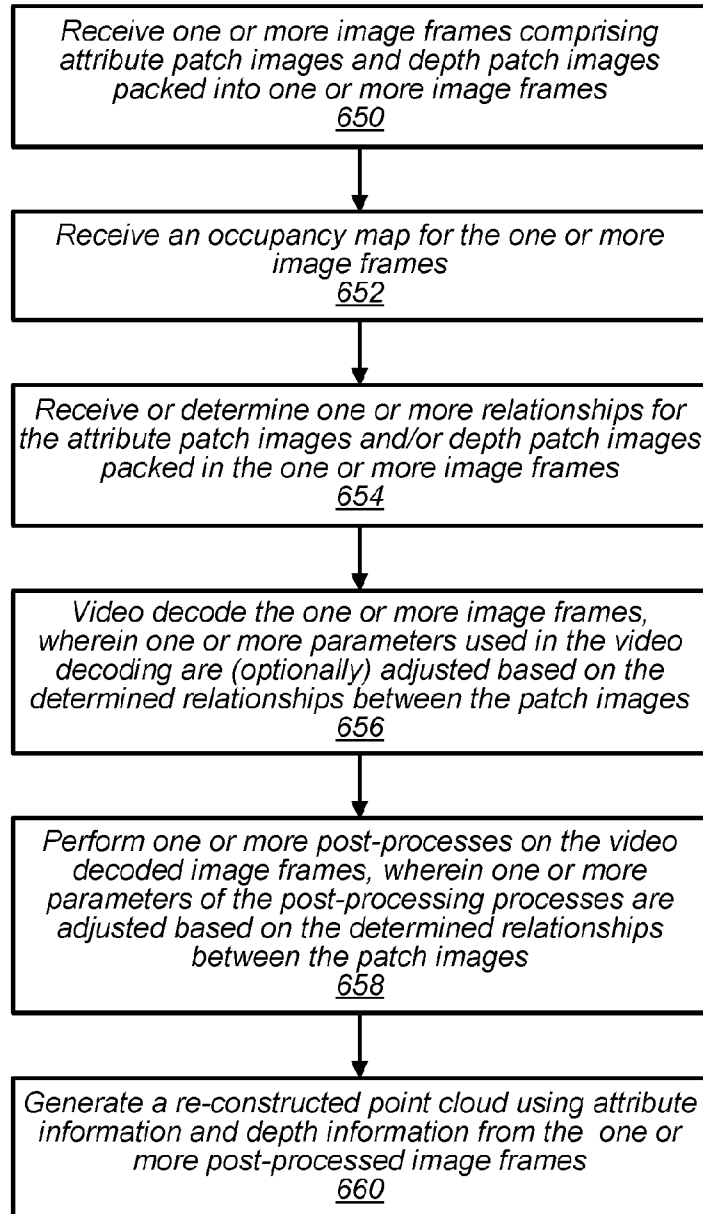

FIG. 6G

30/45

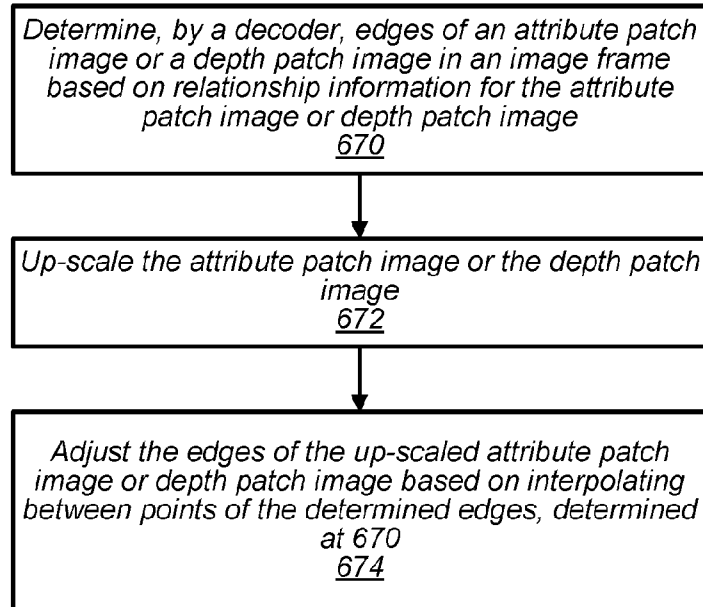

FIG. 6H

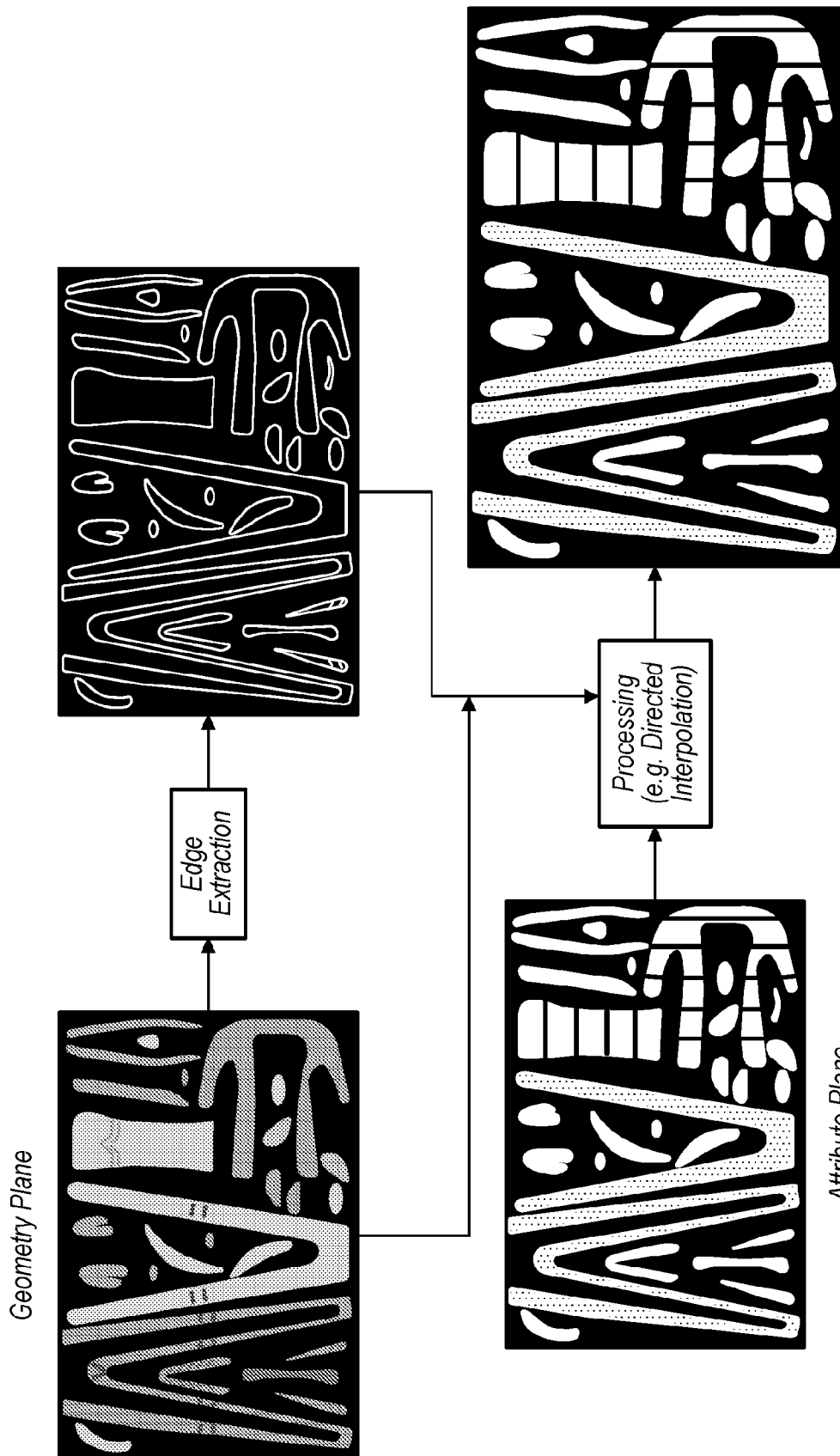

FIG. 6I

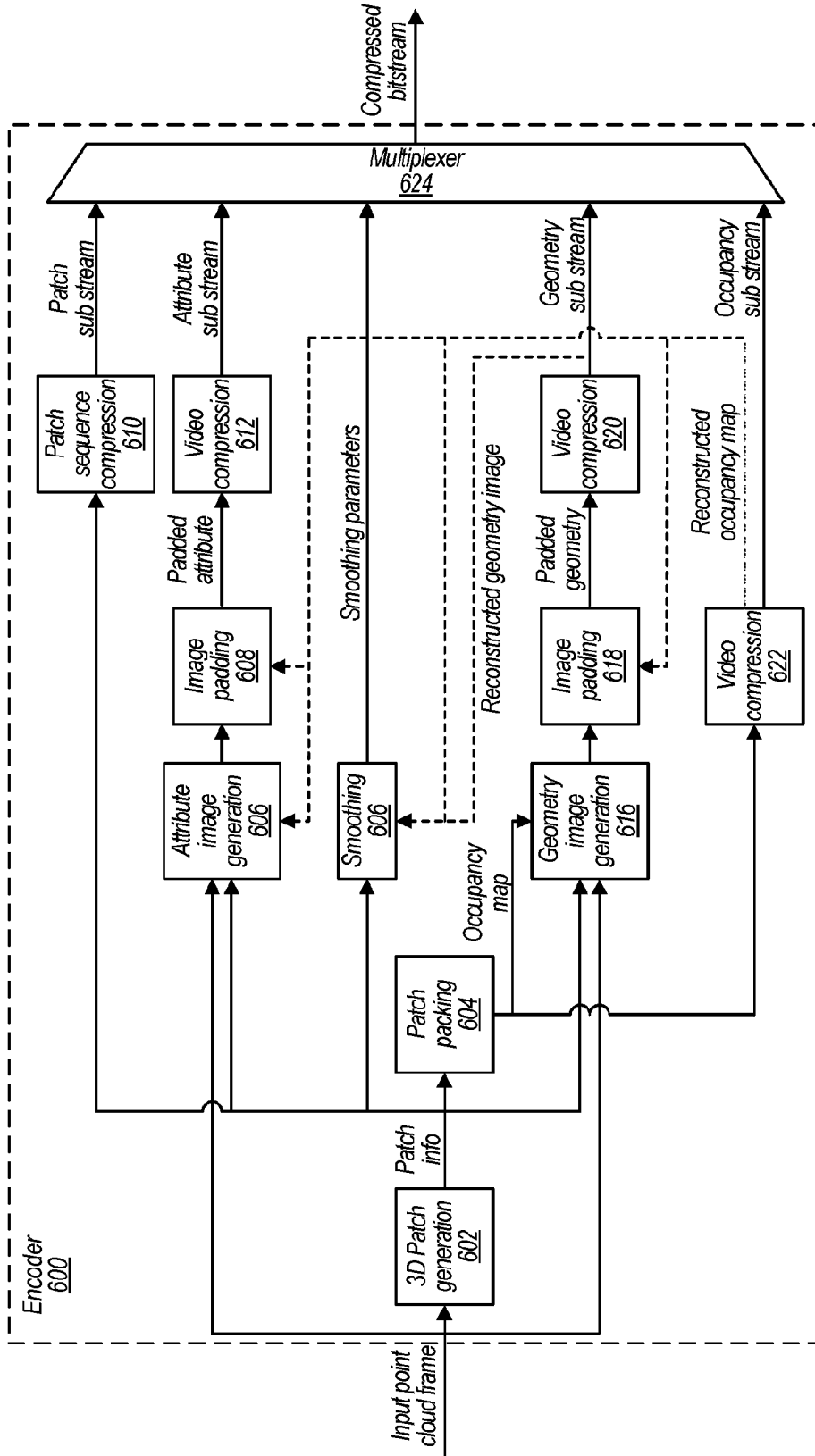

FIG. 6J

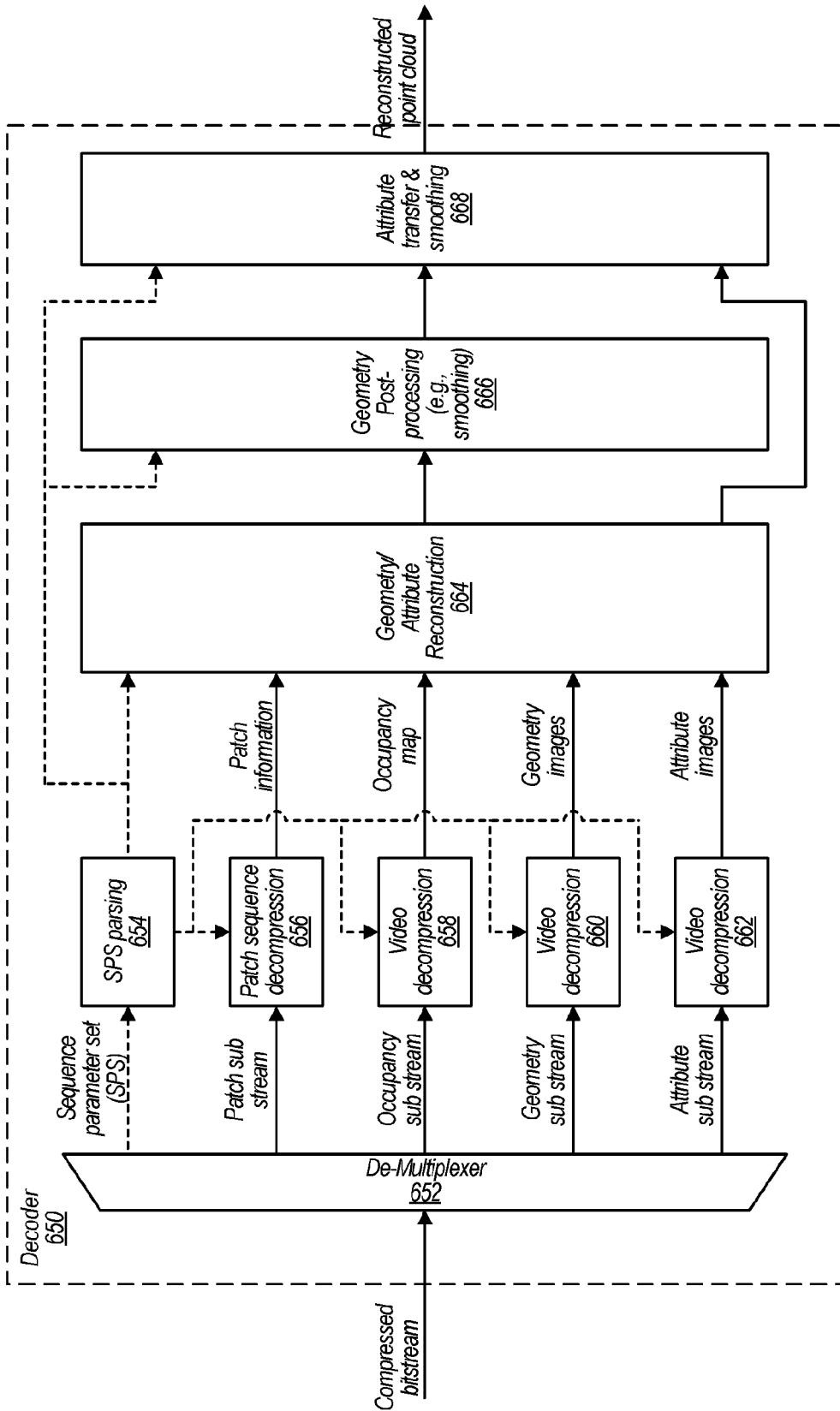

FIG. 6K

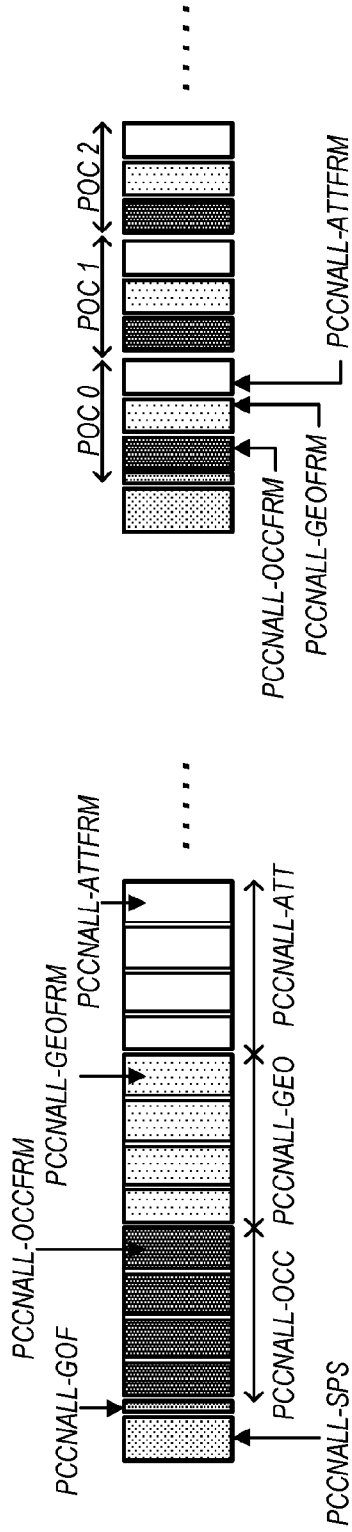

FIG. 7A

FIG. 7B

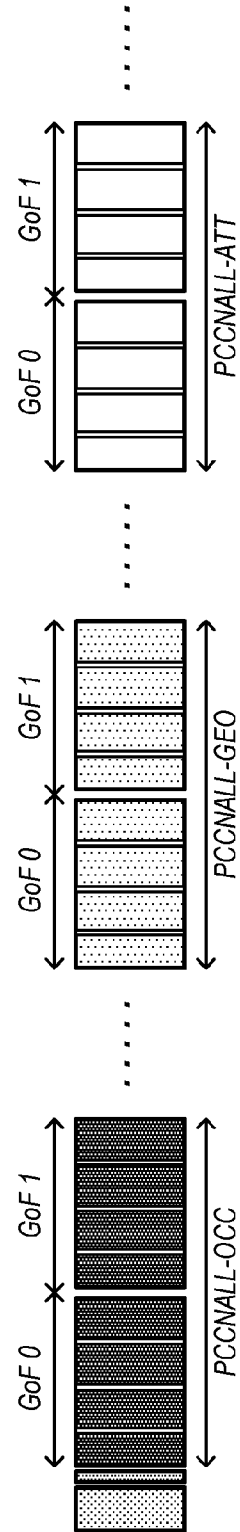

FIG. 7C

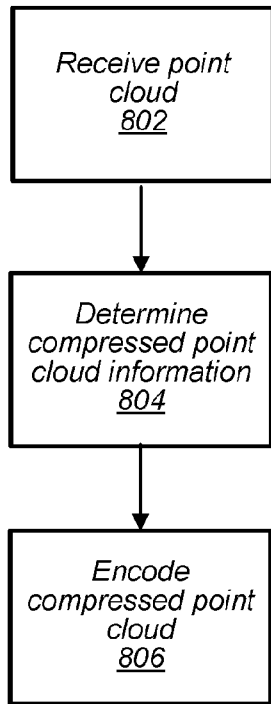

FIG. 8A

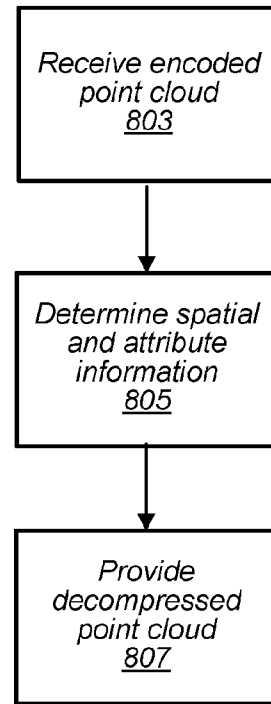

FIG. 8B

36/45

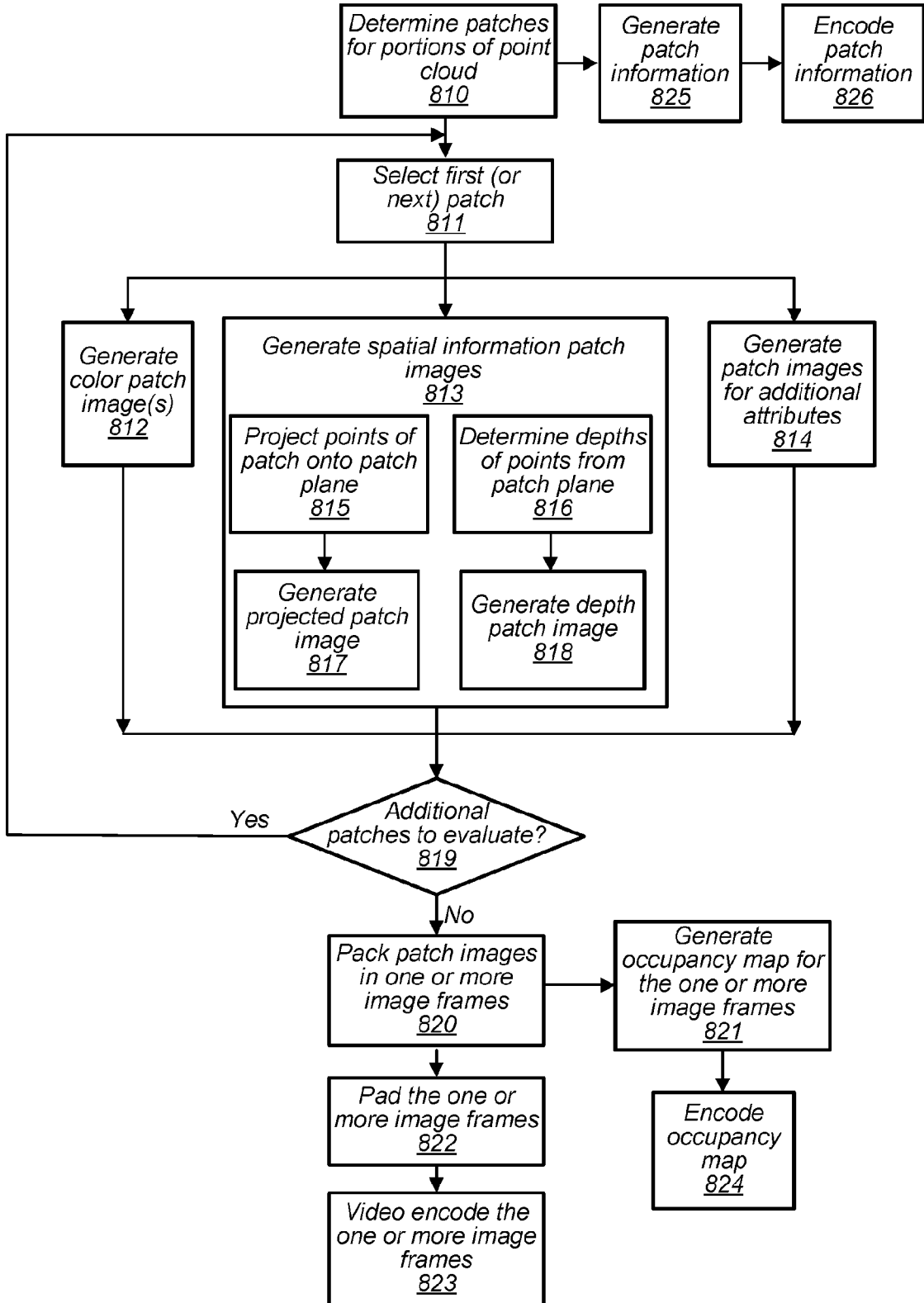

FIG. 8C

37/45

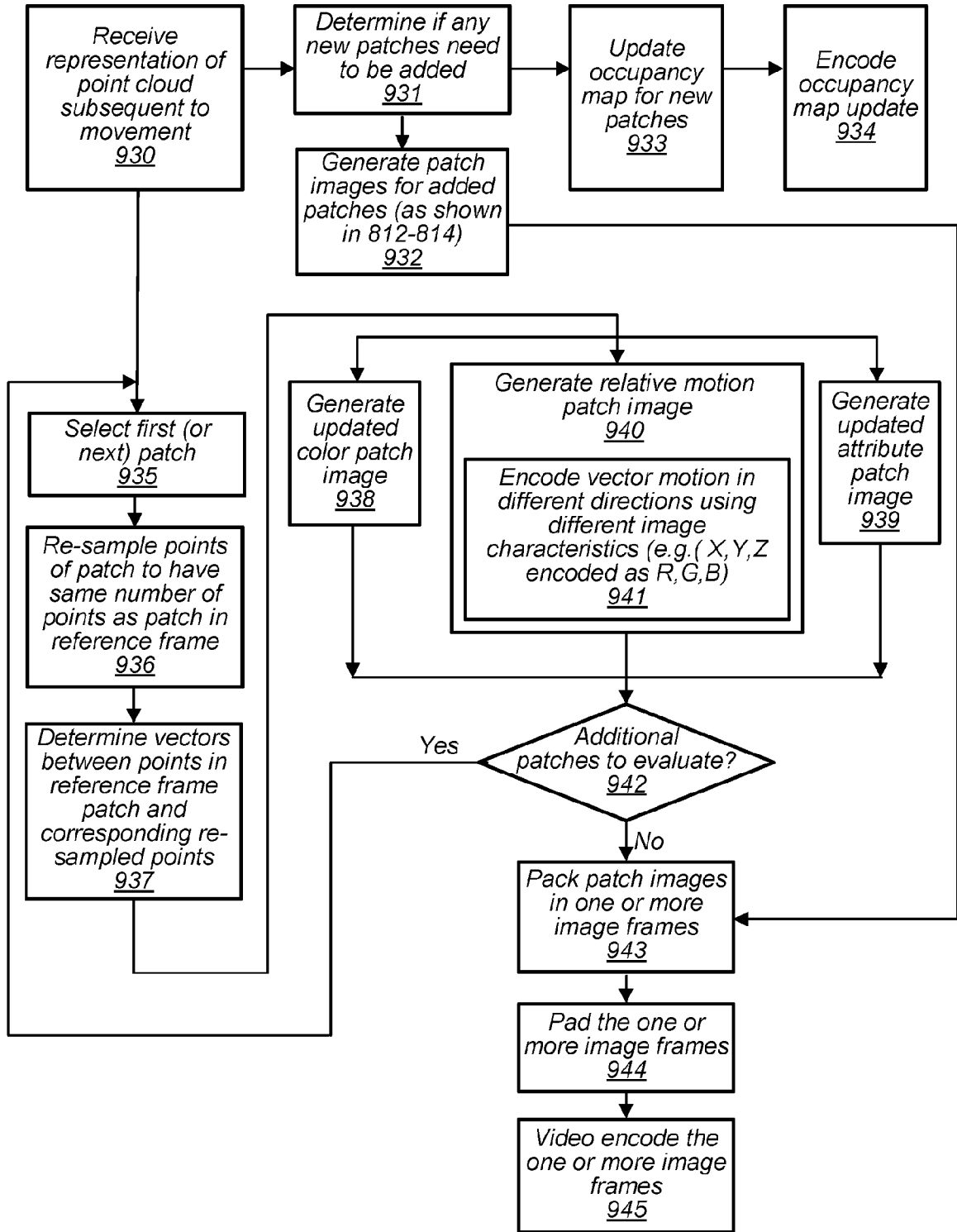

FIG. 9

38/45

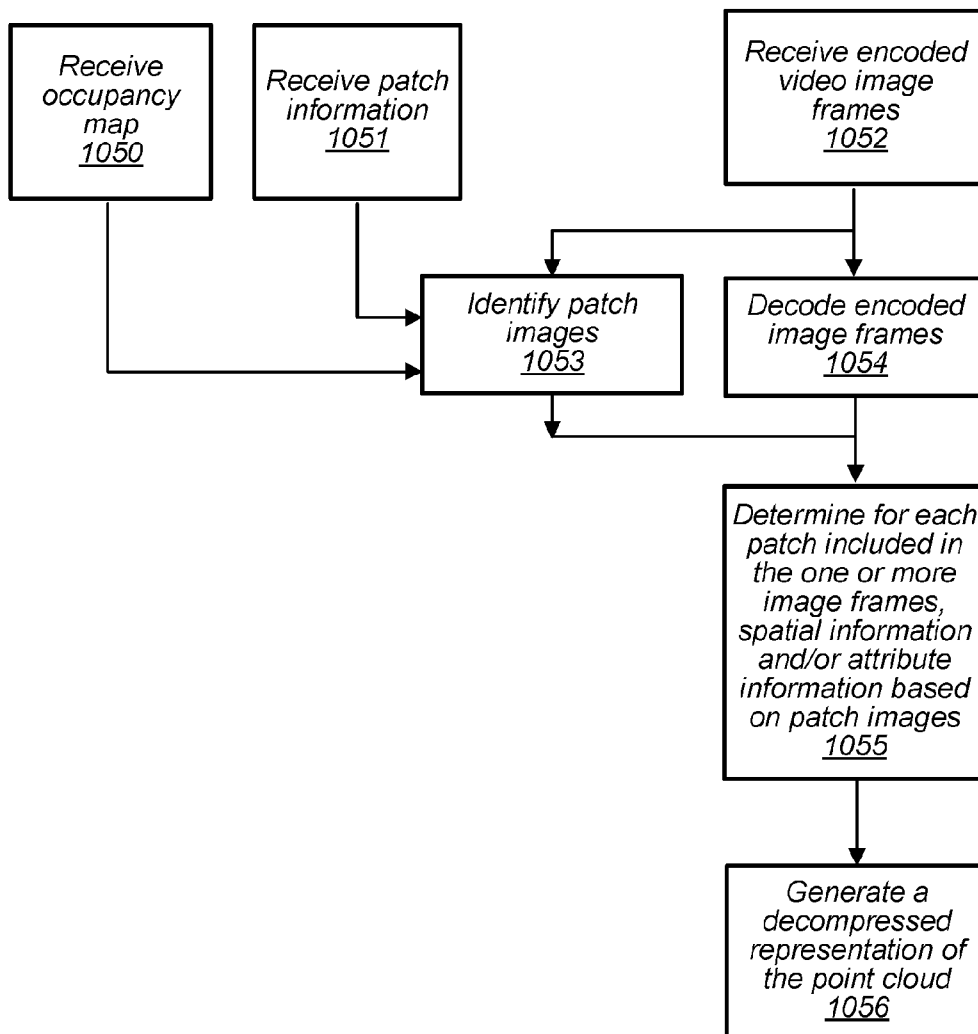

FIG. 10

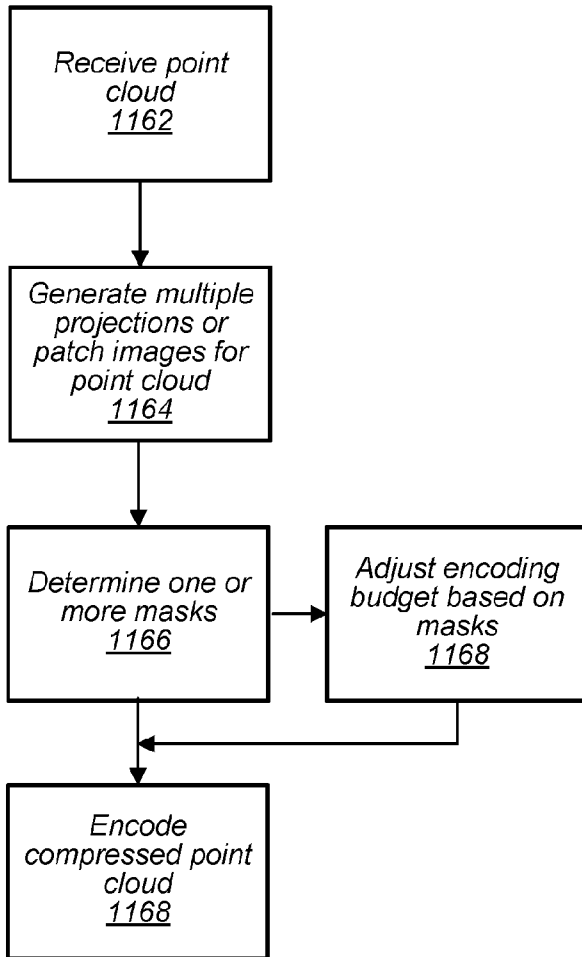

FIG. 11A

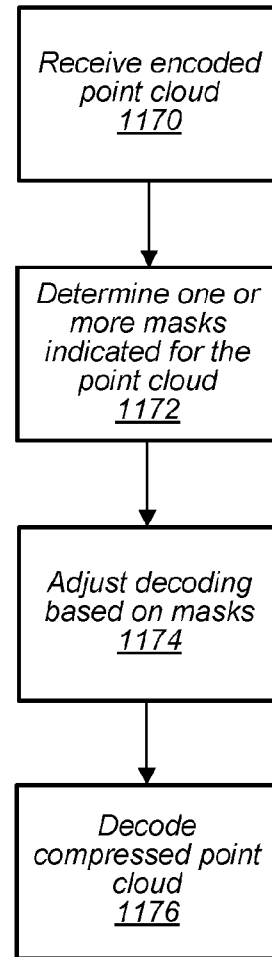

FIG. 11B

40/45

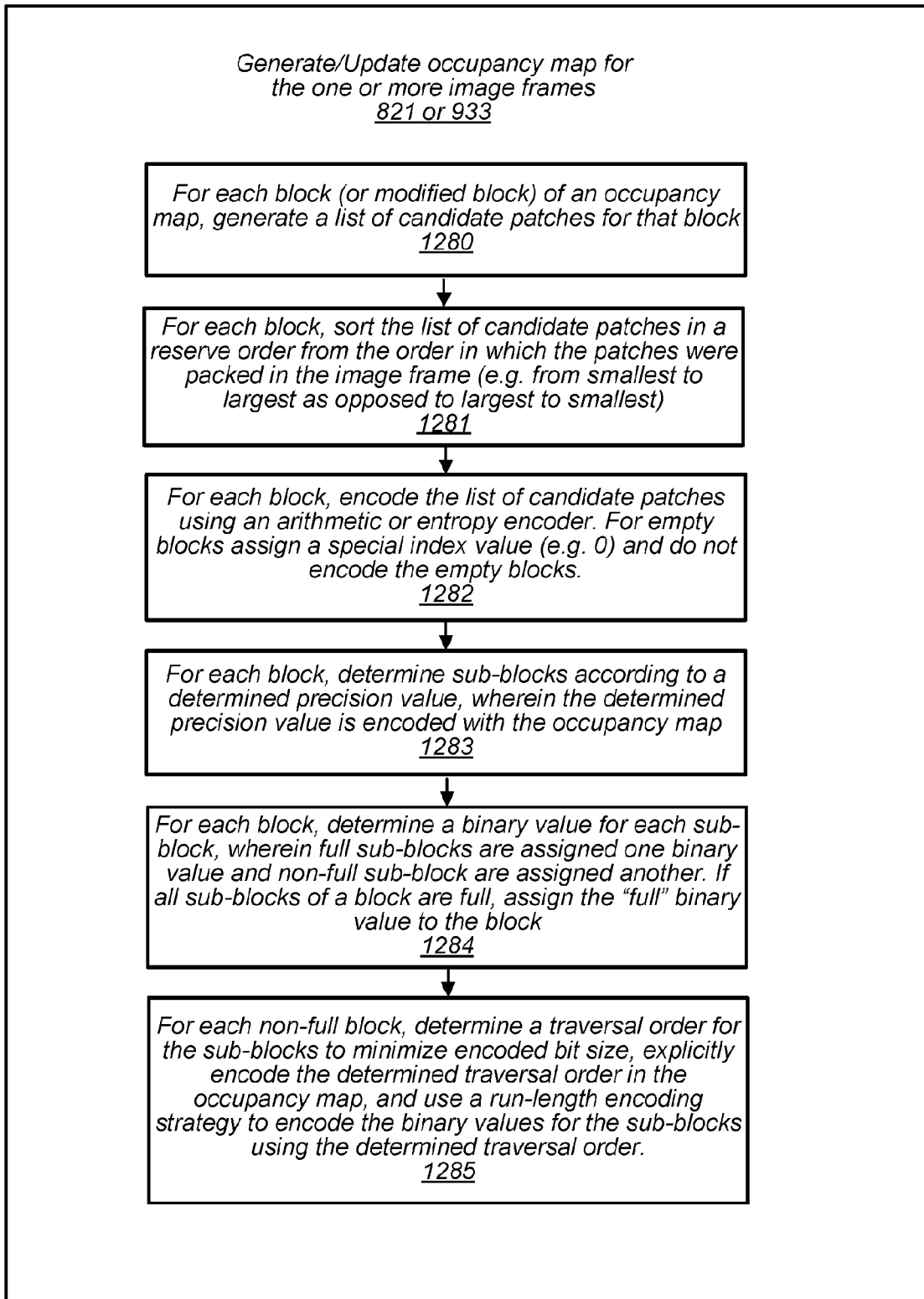

FIG. 12A

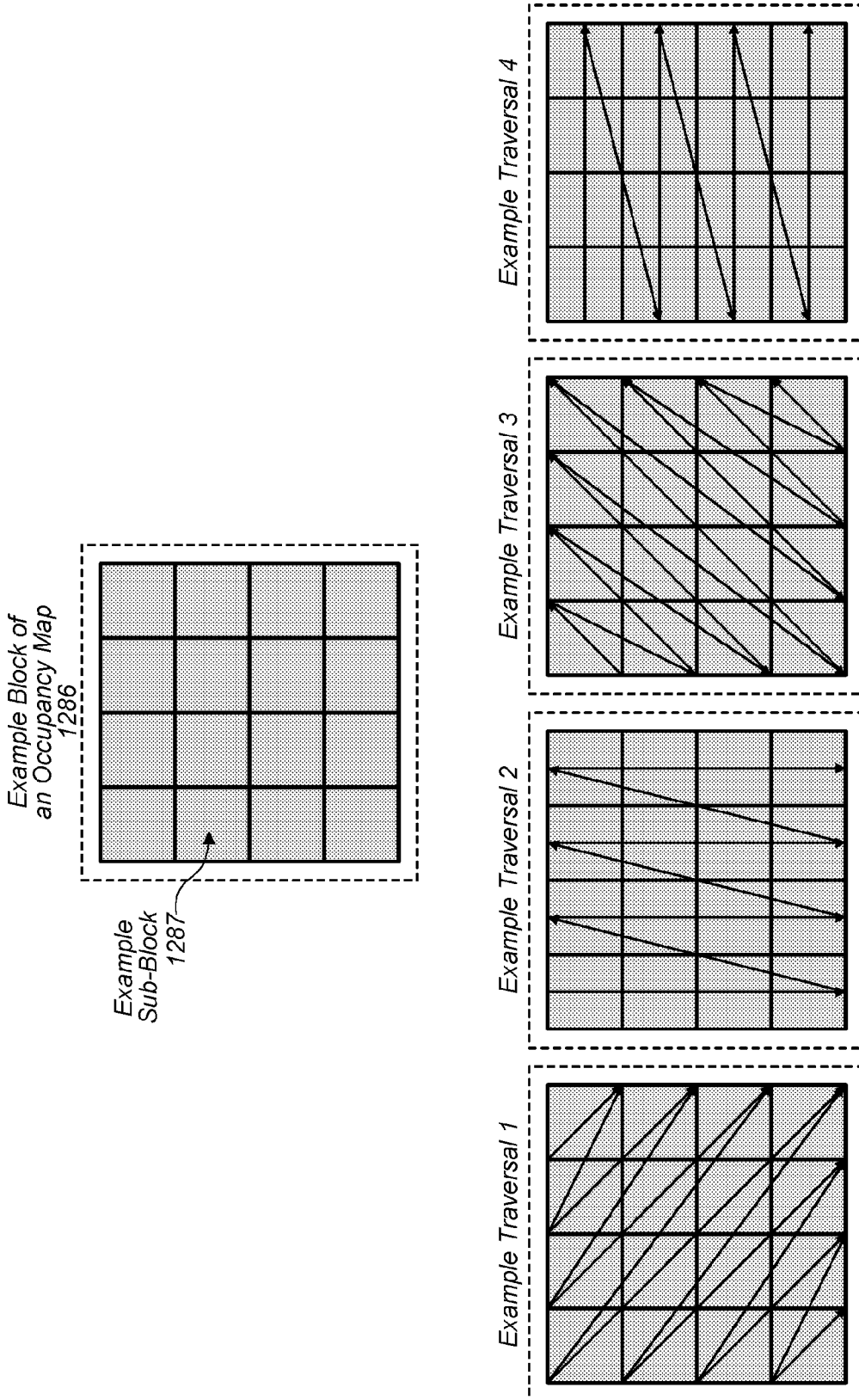

FIG. 12B

42/45

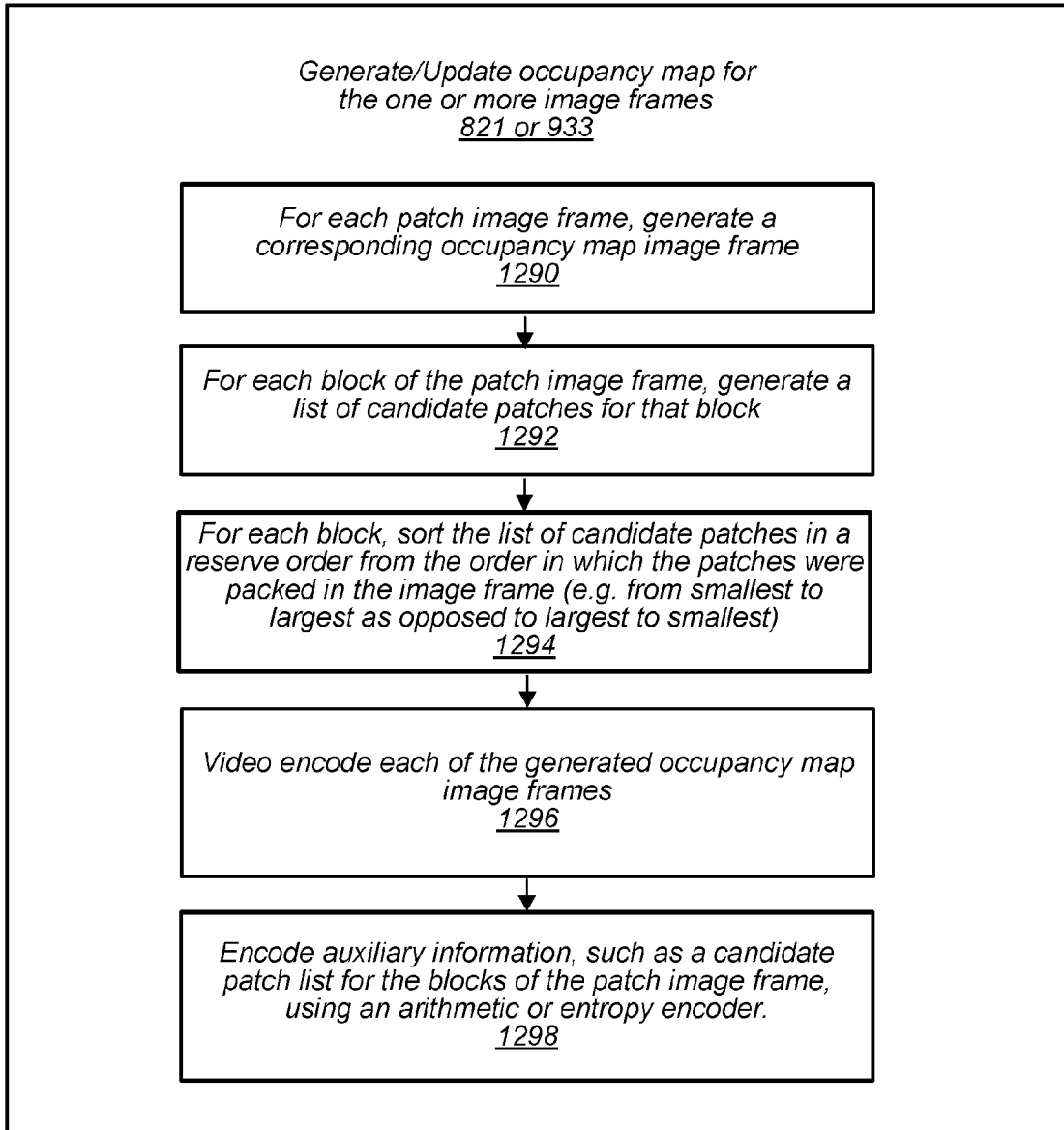

FIG. 12C

43/45

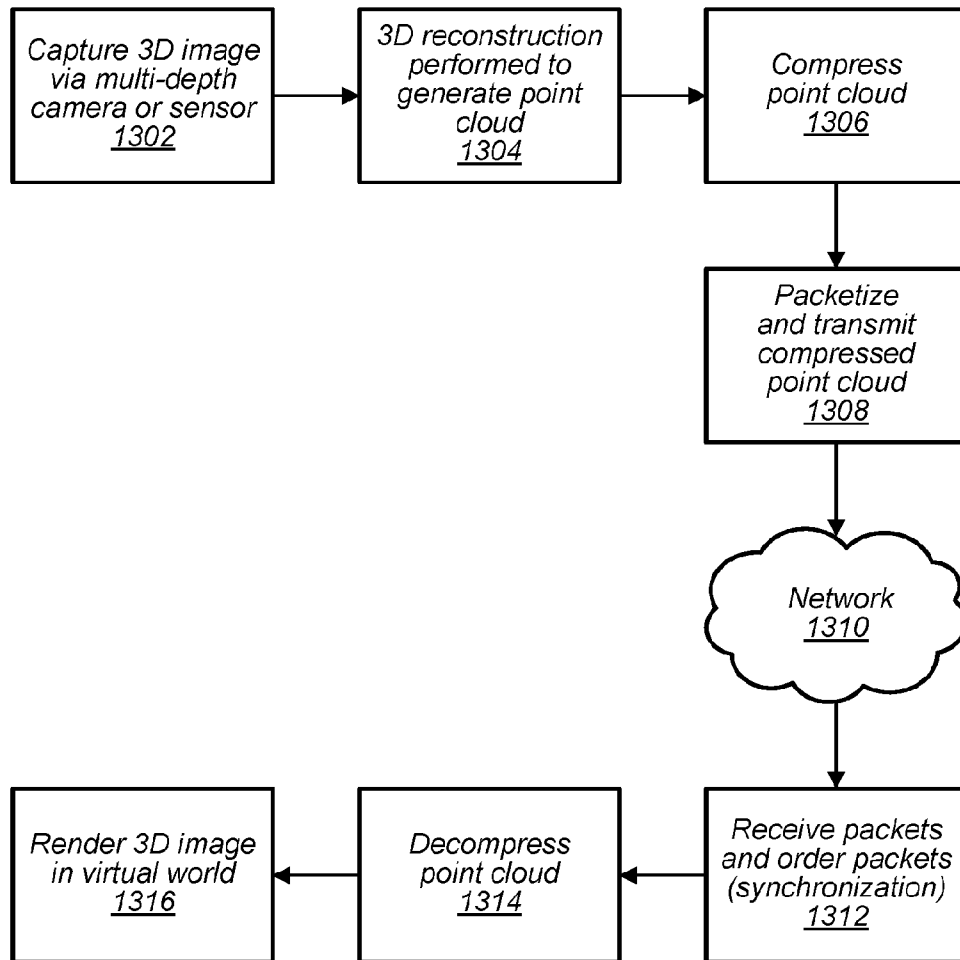

FIG. 13

44/45

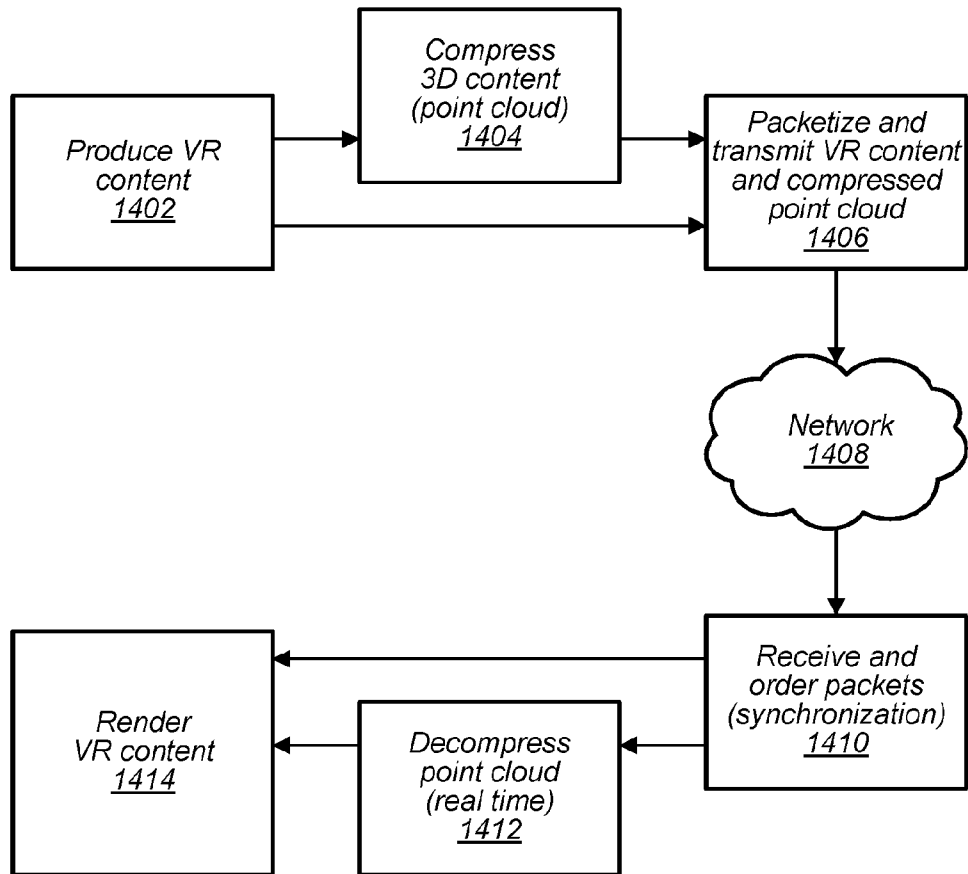

FIG. 14

45/45

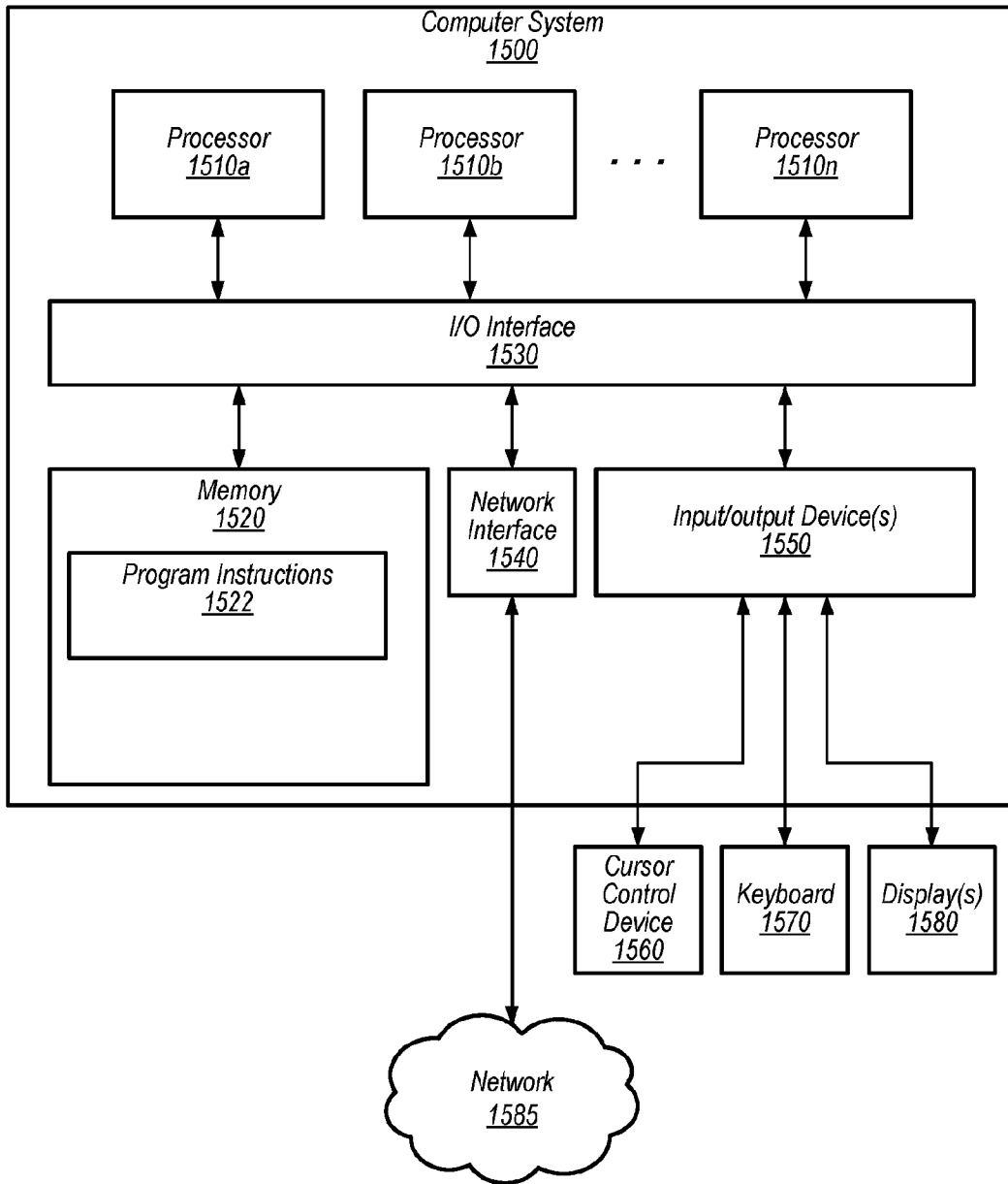

FIG. 15

INTERNATIONAL SEARCH REPORT

International application No PCT/US2020/052900

A. CLASSIFICATION OF SUBJECT MATTER INV. H04N19/597 H04N19/80 ADD.		
According to International Patent Classification (IPC) or to both national classification and IPC		
B. FIELDS SEARCHED Minimum documentation searched (classification system followed by classification symbols) H04N		
Documentation searched other than minimum documentation to the extent that such documents are included in the fields searched		
Electronic data base consulted during the international search (name of data base and, where practicable, search terms used) EPO-Internal		
C. DOCUMENTS CONSIDERED TO BE RELEVANT		
Category*	Citation of document, with indication, where appropriate, of the relevant passages	Relevant to claim No.
X, P	MEHLEM D ET AL: "[V-PCC] Smoothing considerations for V-PCC", 128. MPEG MEETING; 20191007 - 20191011; GENEVA; (MOTION PICTURE EXPERT GROUP OR ISO/IEC JTC1/SC29/WG11), no. m51023 2 October 2019 (2019-10-02), XP030221531, Retrieved from the Internet: URL:http://phenix.int-evry.fr/mpeg/doc_end_user/documents/128_Geneva/wg11/m51023-v1-m51023.zip m51023.docx [retrieved on 2019-10-02] abstract Section 3. Proposed solution Section 4. Extended SEI/EEI messages for geometry and attribute smothing ----- -/--	1-22
<input checked="" type="checkbox"/> Further documents are listed in the continuation of Box C. <input checked="" type="checkbox"/> See patent family annex.		
* Special categories of cited documents :		
"A" document defining the general state of the art which is not considered to be of particular relevance "E" earlier application or patent but published on or after the international filing date "L" document which may throw doubts on priority claim(s) or which is cited to establish the publication date of another citation or other special reason (as specified) "O" document referring to an oral disclosure, use, exhibition or other means "P" document published prior to the international filing date but later than the priority date claimed	"T" later document published after the international filing date or priority date and not in conflict with the application but cited to understand the principle or theory underlying the invention "X" document of particular relevance; the claimed invention cannot be considered novel or cannot be considered to involve an inventive step when the document is taken alone "Y" document of particular relevance; the claimed invention cannot be considered to involve an inventive step when the document is combined with one or more other such documents, such combination being obvious to a person skilled in the art "&" document member of the same patent family	
Date of the actual completion of the international search	Date of mailing of the international search report	
26 November 2020	04/12/2020	
Name and mailing address of the ISA/ European Patent Office, P.B. 5818 Patentlaan 2 NL - 2280 HV Rijswijk Tel. (+31-70) 340-2040, Fax: (+31-70) 340-3016	Authorized officer Hampson, Frances	

INTERNATIONAL SEARCH REPORT

International application No
PCT/US2020/052900

C(Continuation). DOCUMENTS CONSIDERED TO BE RELEVANT		
Category*	Citation of document, with indication, where appropriate, of the relevant passages	Relevant to claim No.
A,P	D. GRAZIOSI ET AL: "An overview of ongoing point cloud compression standardization activities: video-based (V-PCC) and geometry-based (G-PCC)", APSIPA TRANSACTIONS ON SIGNAL AND INFORMATION PROCESSING, vol. 9, 30 April 2020 (2020-04-30), XP055737775, DOI: 10.1017/ATSIP.2020.12 Section III Video-based point cloud compression	1-22
A	----- US 2019/087979 A1 (MAMMOU KHALED [CA] ET AL) 21 March 2019 (2019-03-21) abstract paragraph [0105] paragraph [0259] paragraph [0326] - paragraph [0328] paragraph [0350] - paragraph [0351] paragraph [0608] figures 5a,5b,6a	1-22
A	----- "Continous improvement of Study Text of ISO/IEC CD 23090-5 Video-based Point Cloud Compression", 126. MPEG MEETING; 20190325 - 20190329; GENEVA; (MOTION PICTURE EXPERT GROUP OR ISO/IEC JTC1/SC29/WG11), , no. n18479 8 May 2019 (2019-05-08), XP030208744, Retrieved from the Internet: URL:http://phenix.int-evry.fr/mpeg/doc_end_user/documents/126_Geneva/wg11/w18479.zip w18479 V-PCC_SCD.docx [retrieved on 2019-05-08] Section 8 Decoding process ----- -/--	1-22

INTERNATIONAL SEARCH REPORT

International application No
PCT/US2020/052900

C(Continuation). DOCUMENTS CONSIDERED TO BE RELEVANT		
Category*	Citation of document, with indication, where appropriate, of the relevant passages	Relevant to claim No.
A	<p>"V-PCC Codec description", 127. MPEG MEETING; 20190708 - 20190712; GOTHENBURG; (MOTION PICTURE EXPERT GROUP OR ISO/IEC JTC1/SC29/WG11), , no. n18674 25 September 2019 (2019-09-25), XP030206834, Retrieved from the Internet: URL:http://phenix.int-evry.fr/mpeg/doc_end _user/documents/127_Gothenburg/wg11/w18674 .zip N18674_VPCC_TMv7_AlgorithmDescription_d1.d ocx [retrieved on 2019-09-25] Section 2 Description of coding features and encoding methods figures 1,2</p>	1-22
A	<p>----- SCHWARZ SEBASTIAN ET AL: "Emerging MPEG Standards for Point Cloud Compression", IEEE JOURNAL ON EMERGING AND SELECTED TOPICS IN CIRCUITS AND SYSTEMS, IEEE, PISCATAWAY, NJ, USA, vol. 9, no. 1, 30 March 2019 (2019-03-30), pages 133-148, XP011714044, ISSN: 2156-3357, DOI: 10.1109/JETCAS.2018.2885981 abstract Section VII. Video-based point cloud compression figures 11,12 -----</p>	1-22

INTERNATIONAL SEARCH REPORT

Information on patent family members

International application No
PCT/US2020/052900

Patent document cited in search report	Publication date	Patent family member(s)	Publication date	
US 2019087979	A1	21-03-2019	CN 111133476 A	08-05-2020
			DE 112018005250 T5	18-06-2020
			KR 20200038534 A	13-04-2020
			US 2019087979 A1	21-03-2019
			WO 2019055963 A1	21-03-2019
