



(19) **United States**

(12) **Patent Application Publication**
Chen et al.

(10) **Pub. No.: US 2020/0120019 A1**

(43) **Pub. Date: Apr. 16, 2020**

(54) **APPARATUS AND METHOD FOR COMMUNICATION BETWEEN CHAINS IN A DECENTRALIZED SYSTEM**

(52) **U.S. Cl.**
CPC **H04L 45/44** (2013.01); **H04L 9/3247** (2013.01); **H04L 9/0861** (2013.01)

(71) Applicant: **MOAC BLOCKCHAIN TECH INC,**
Palo Alto, CA (US)

(57) **ABSTRACT**

(72) Inventors: **Xiaohu Chen,** Mountain View, CA (US); **Xinle Yang,** Portland, OR (US); **Zhengpeng Li,** Columbia, MD (US); **Qing Xu,** Palo Alto, CA (US); **Yuechao Ma,** Seattle, WA (US); **Xiannong Fu,** Irvine, CA (US); **Yang Chen,** Bellevue, WA (US)

A packet including a message intended for a smart contract associated with the second subchain and a node identifier is constructed at each of a plurality of nodes associated with the first subchain. The message constructed by the plurality of nodes are identical and may be a transaction request requesting the smart contract to execute on a blockchain. Each of the packets is sent to one or more nodes associated with the second subchain. The packets and messages received by one or more of a plurality of nodes associated with the second subchain are monitored and processed at the second subchain to determine if a consensus on request has been reached from the first subchain. If a consensus on request has been reached from the first subchain, the smart contract associated with the second subchain executes on the blockchain in accordance with the transaction request.

(21) Appl. No.: **16/160,605**



(22) Filed: **Oct. 15, 2018**

Publication Classification

(51) **Int. Cl.**
H04L 12/721 (2006.01)
H04L 9/08 (2006.01)
H04L 9/32 (2006.01)

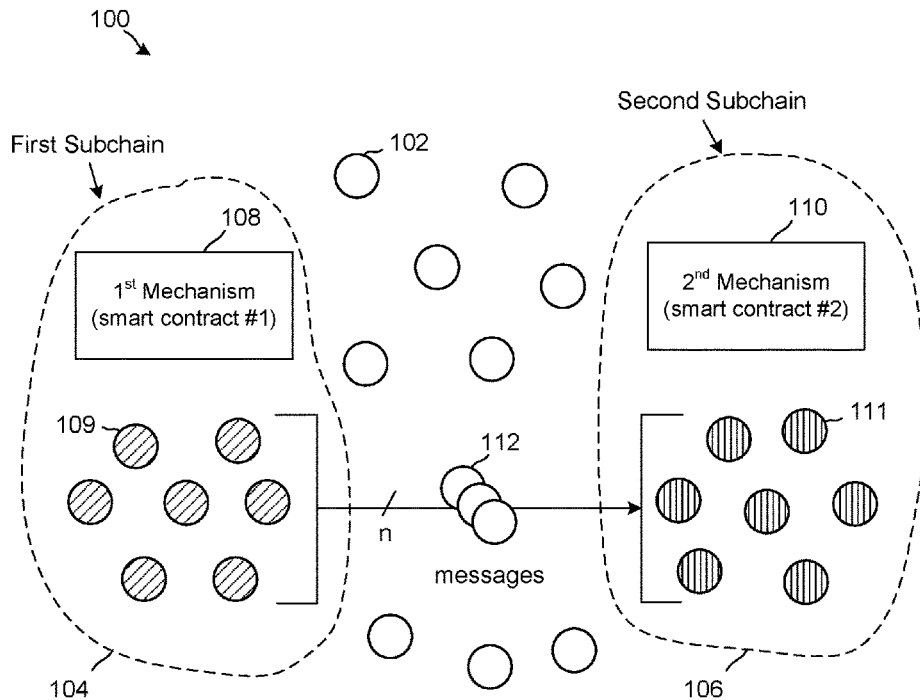
Large-Scale Decentralized Network



-  first subchain node (upper layer)
-  second subchain node (upper layer)
-  lower-layer node

Large-Scale Decentralized Network

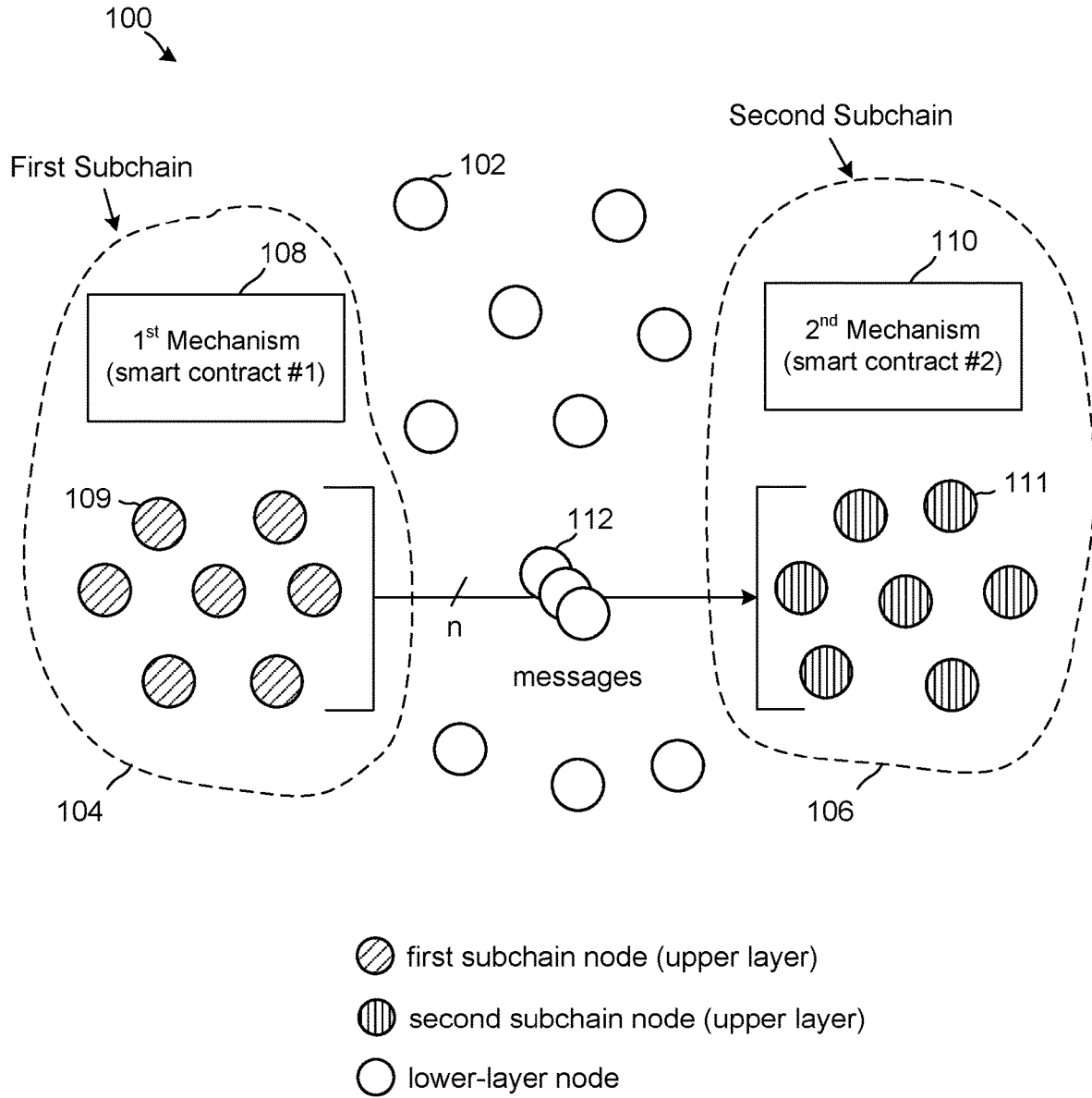

FIG. 1

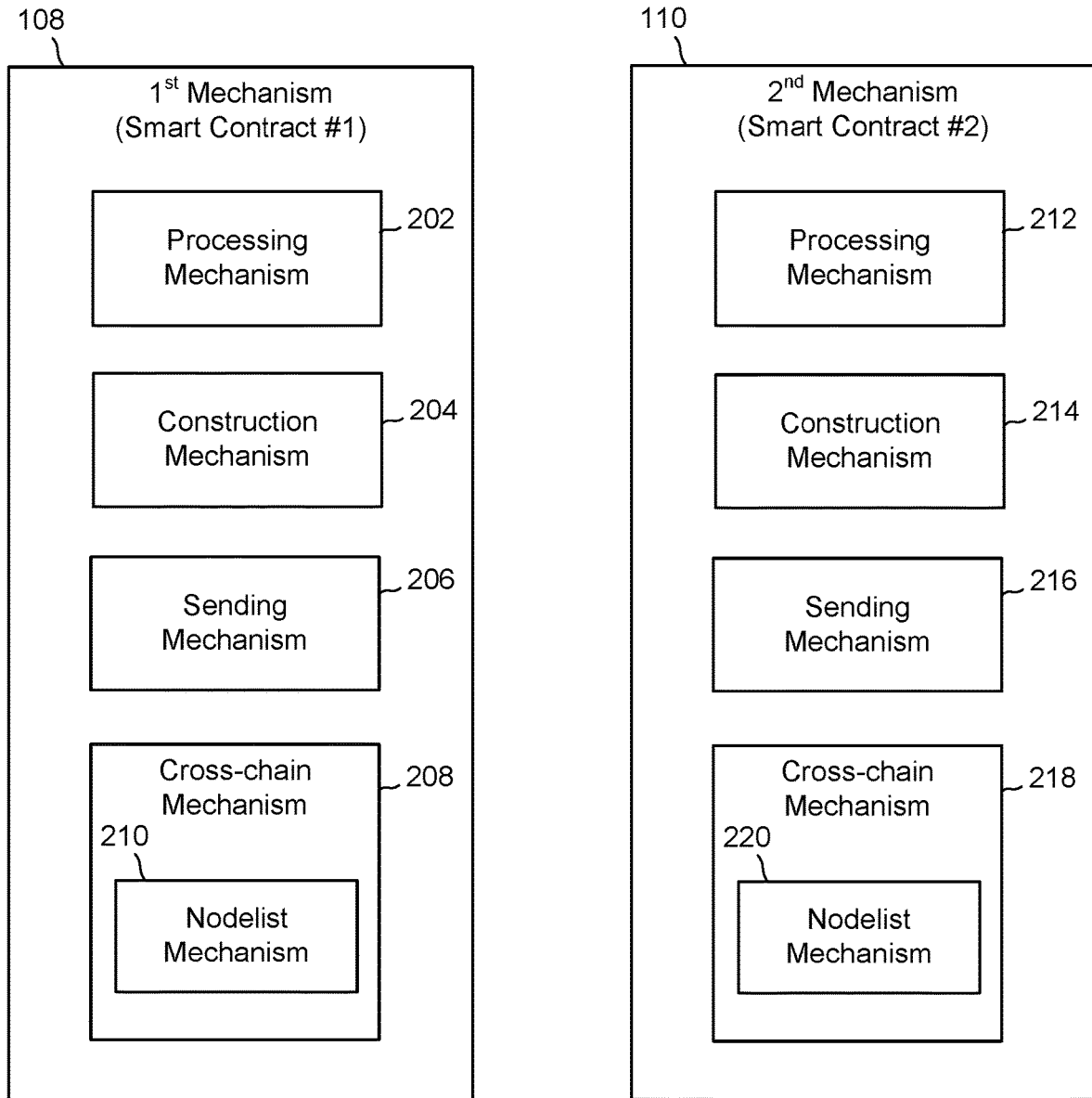

FIG. 2

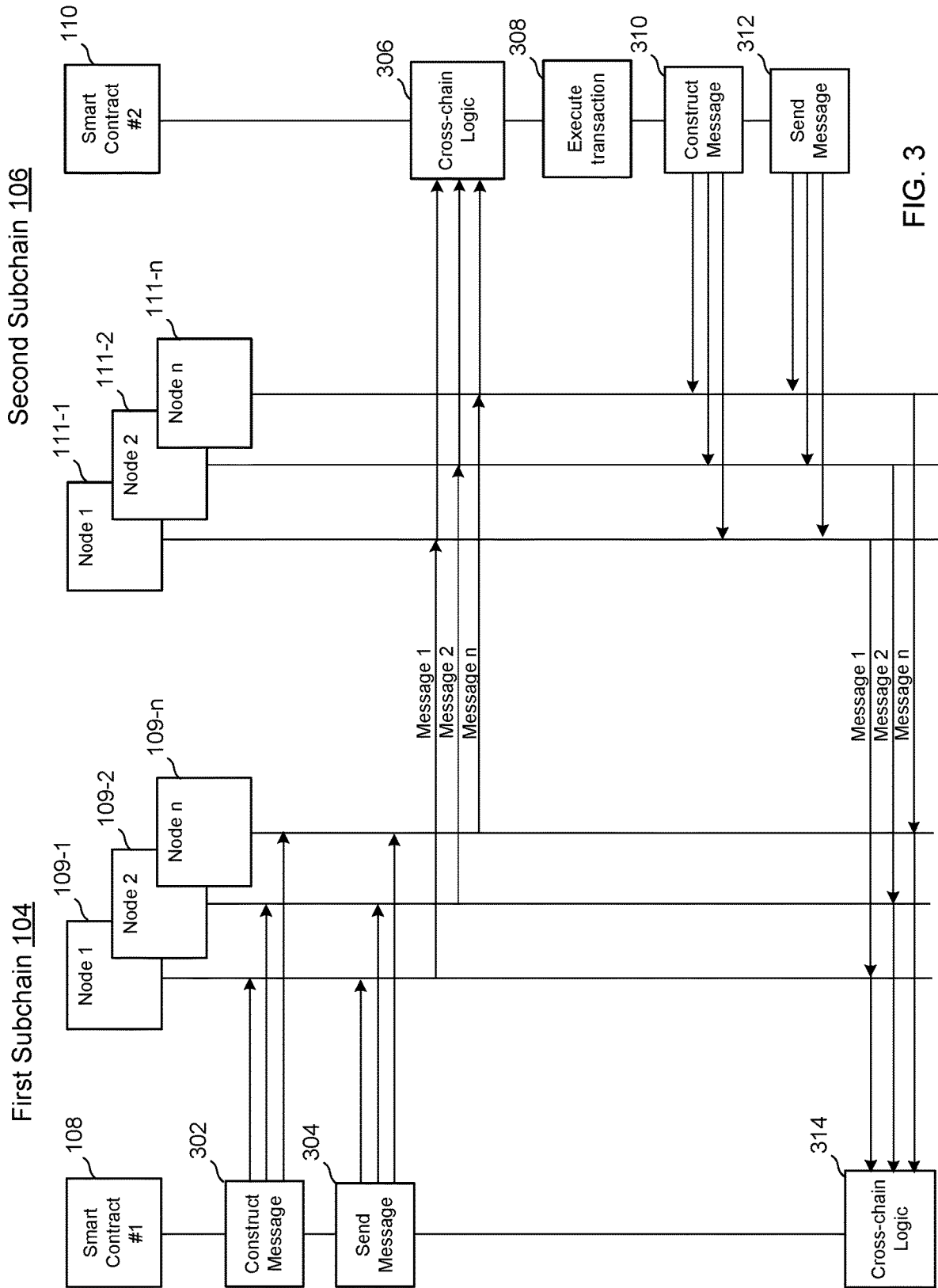

FIG. 3

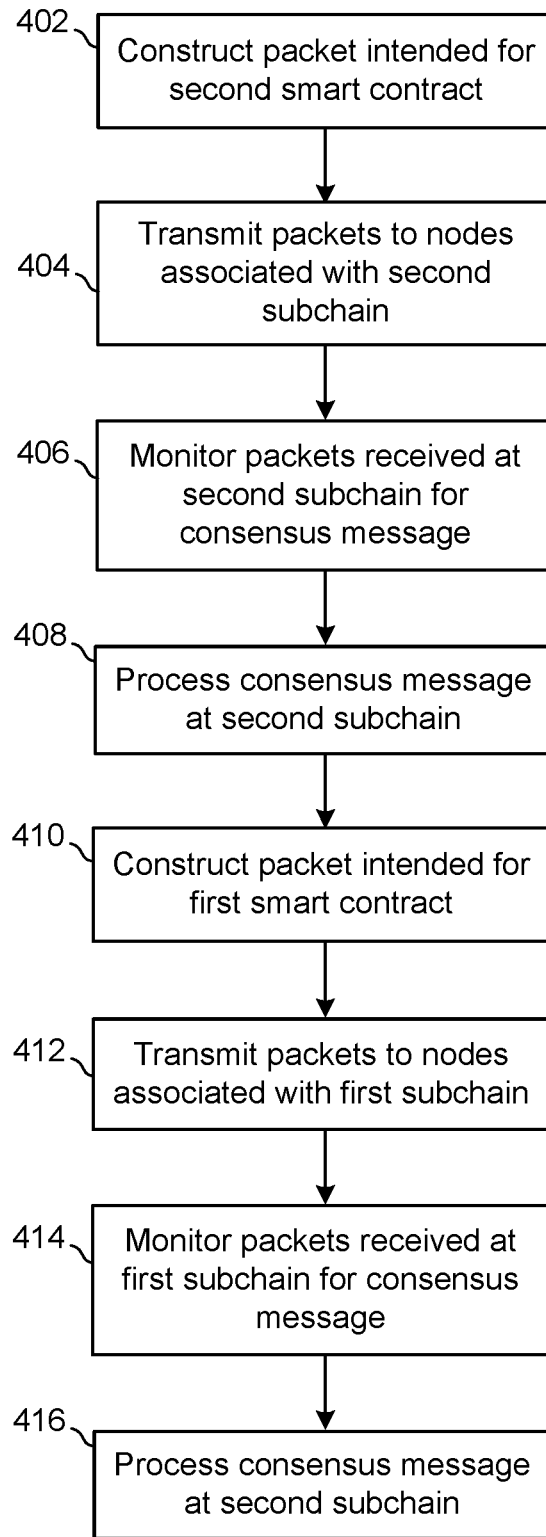

FIG. 4

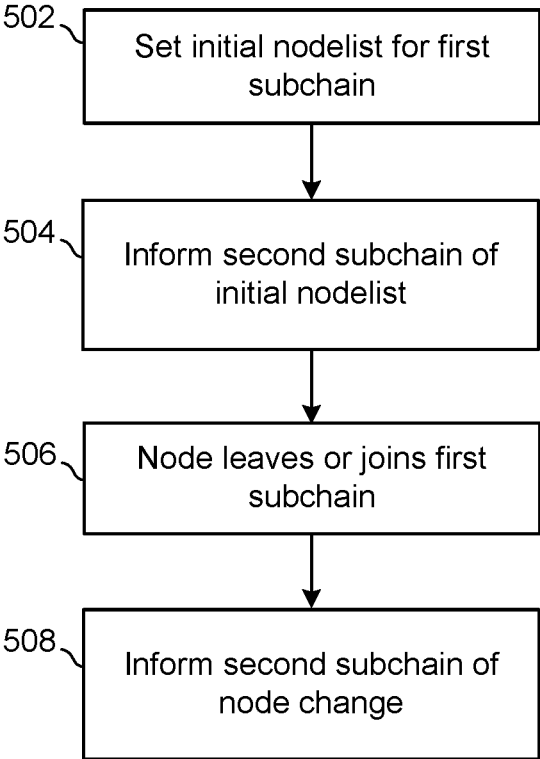

FIG. 5

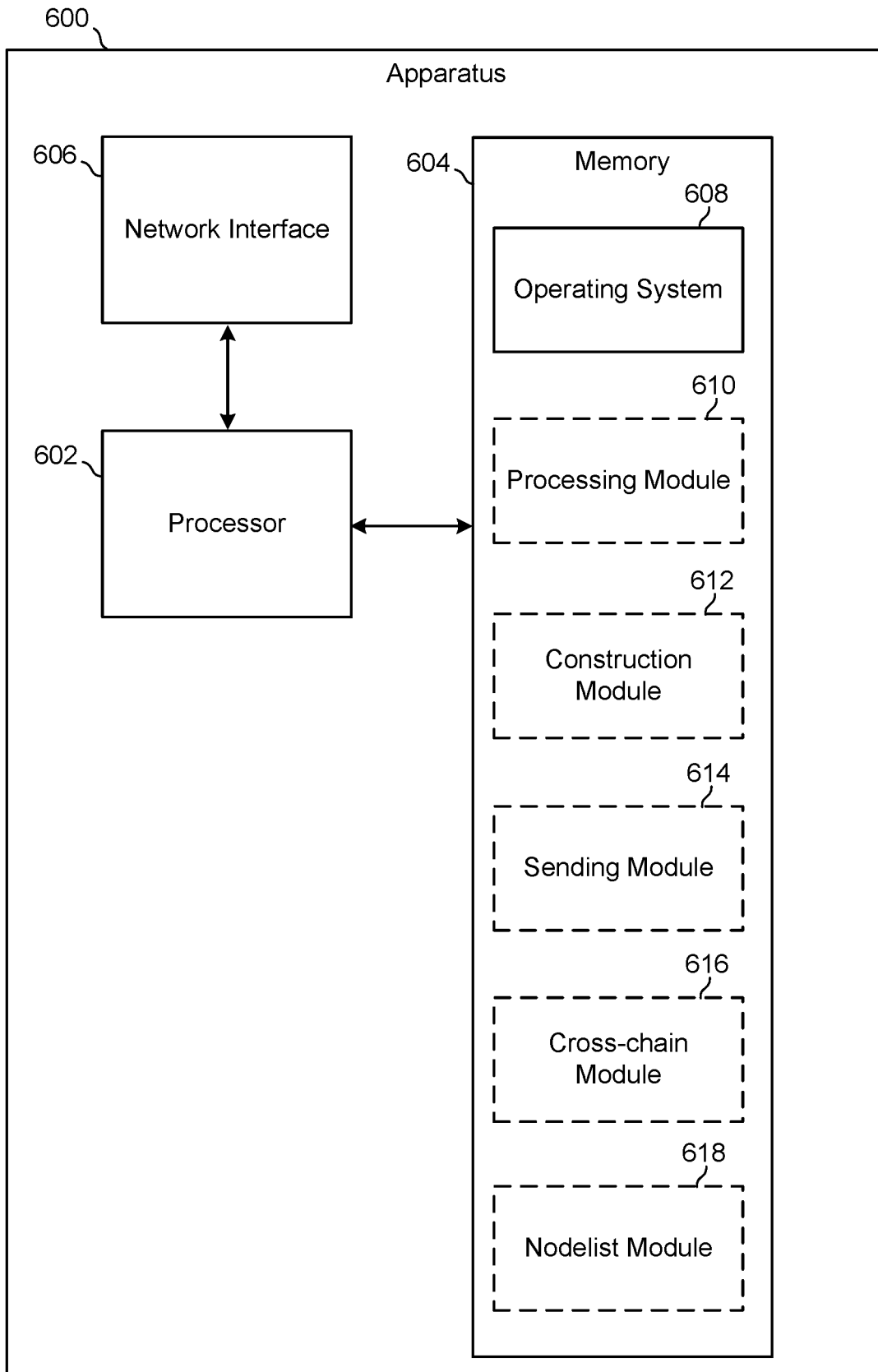

FIG. 6

APPARATUS AND METHOD FOR COMMUNICATION BETWEEN CHAINS IN A DECENTRALIZED SYSTEM

TECHNICAL FIELD

[0001] The present disclosure relates generally to communication over large-scale networks, and more particularly, to apparatuses and methods that provide for communication between subchains in a decentralized system.

BACKGROUND

[0002] A blockchain system may be implemented in peer-to-peer network having a large number of distributed nodes forming a large-scale decentralized network. The number of nodes in a large-scale decentralized network may be, for example, around 10,000. In a decentralized blockchain system, the ability to efficiently process tasks, such as transactions or smart contract calls, is critical. To improve the efficiency and capacity of blockchain, the distributed nodes within the large-scale decentralized network may be divided into multiple groups, each group forming a separate blockchain that handles one task at a time. Each of these separate blockchains is usually called a subchain.

[0003] Typically, each separate blockchain processes a certain application. In the case of complex application involving multiple tasks, it is desirable to be able to divide the tasks among multiple blockchains. Doing so requires the blockchains to communicate with each other to coordinate execution of the various tasks. Communication between blockchains may be implemented using a centralized approach or a decentralized approach.

[0004] In a centralized approach, a node in a first blockchain sends a transaction request message to an address of a node in a second blockchain. A node of the second blockchain executes the requests and sends an execution reply message back to the first blockchain. A drawback of the centralized approach is that for each transmitted request or reply message, the address of the node from which that message originated is a single point of failure. Accordingly, if that address is compromised, the entire blockchain structure may be compromised.

[0005] In a decentralized scenario, transaction request messages and execution reply messages are originated by a smart contract with a consensus protocol that is associated with each respective blockchain. Execution within each blockchain is done by a consensus result, independent of any single node within either blockchain. A smart contract can be identified by an address. However, because the smart contract only resides inside one blockchain, its identity cannot be verified by another blockchain. Thus, direct communication between smart contracts in different blockchains is not possible.

[0006] It is therefore desirable to have decentralized communication between blockchains, wherein the identities of respective smart contracts are verifiable by respective blockchains and direct communication between smart contracts is possible. The concepts disclosed below address this need and others.

SUMMARY

[0007] A mechanism for facilitating communication between a first subchain and a second subchain in a decentralized network includes a construction mechanism and a

sending mechanism. The construction mechanism includes construction logic that initiates the construction of a packet at each of a plurality of nodes associated with the first subchain. The packet includes a message intended for a smart contract associated with the second subchain and a node identifier. The messages constructed by each of the plurality of nodes are identical, and may correspond to one of a transaction request or a transaction reply or other information. The node identifier may correspond to a signature signed by the private key of the node. The sending mechanism including sending logic that causes each node that has constructed a packet, to transmit its packet to one or more nodes associated with the second subchain.

[0008] In an aspect, the mechanism further includes a cross-chain mechanism that includes cross-chain logic that monitors packets received by one or more of the plurality of nodes associated with the first subchain to determine if a consensus on request has been reached from another subchain. The cross-chain mechanism includes nodelist logic that accesses a nodelist that includes node identifiers for a plurality of nodes associated with the other subchain. The other subchain may be the same subchain as the second subchain or it may be a different subchain. The cross-chain logic is configured to determine that a consensus on request is reached when an identical message has been received from a threshold measure of nodes identified in the nodelist. For example, in one embodiment, if an identical message is received from 51% of the nodes identified in the nodelist then a consensus on request is determined to have been reached. If a consensus on request is reached, a processing mechanism processes the identical message (also referred to herein as a consensus message). For example, if the consensus message is a transaction request, the processing mechanism executes the transaction. If the cross-chain logic determines that a consensus on request has not been reached, then the messages received from the other subchain are ignored.

[0009] A smart contract embodied in at least one of a plurality of nodes associated with a first subchain includes logic that causes each of the plurality of nodes associated with the first subchain to construct a packet including a message intended for a smart contract associated with a second subchain and a node identifier. The messages constructed by each of the plurality of nodes are identical, and may correspond to one of a transaction request or a transaction reply or other information. The node identifier may correspond to a signature signed by the private key of the node. The smart contract causes each of the plurality of nodes to transmit its packet to one or more nodes associated with the second subchain.

[0010] In an aspect, the smart contract also includes cross-chain logic that monitors packets received by one or more of the plurality of nodes associated with the first subchain to determine if a consensus on request has been reached from another subchain. The other subchain may be the same subchain as the second subchain or it may be a different subchain. The cross-chain logic of the smart contract includes nodelist logic that obtains a nodelist that includes node identifiers for a plurality of nodes associated with the other subchain, and a consensus on request is determined to have been reached when an identical message has been received from a threshold measure of nodes included in the nodelist. For example, in one embodiment, if an identical message is received from 51% of the nodes identified in the

odelist then a consensus on request is determined to have been reached. If a consensus on request is reached, the smart contract processes the identical message (also referred to herein as a consensus message).

[0011] An apparatus for facilitating communication between a first subchain and a second subchain in a decentralized network includes a network interface, a memory having smart contract logic, and a processor coupled to the network interface and the memory. The processor is configured to execute the smart contract logic to cause each of a plurality of nodes associated with the first subchain to construct a packet including a message intended for a smart contract associated with the second subchain and a node identifier. The messages constructed by each of the plurality of nodes are identical, and may correspond to one of a transaction request or a transaction reply or other information. The node identifier may correspond to a signature signed by the private key of the node. The processor is also configured to execute the smart contract logic to thereby cause each of the plurality of nodes to transmit its packet to one or more nodes associated with the second subchain.

[0012] In an aspect of the apparatus, the processor is further configured to execute the smart contract logic to monitor packets received by one or more of the plurality of nodes associated with the first subchain to determine if a consensus on request has been reached from another subchain. The other subchain may be the same subchain as the second subchain or it may be a different subchain. Nodelist logic of the smart contract obtains a nodelist that includes node identifiers for a plurality of nodes associated with the other subchain, and a consensus on request is determined to have been reached when an identical message has been received from a threshold measure of nodes included in the nodelist. For example, in one embodiment, if an identical message is received from 51% of the nodes identified in the nodelist then a consensus on request is determined to have been reached. If a consensus on request is reached, the processor executes the smart contract logic that processes the identical message (also referred to herein as a consensus message).

[0013] A method of communication between a first subchain and a second subchain in a decentralized network includes constructing a packet at each of a plurality of nodes associated with the first subchain. The packet includes a message intended for a smart contract associated with the second subchain and a node identifier. The messages constructed by each of the plurality of nodes are identical, and may correspond to one of a transaction request or a transaction reply or other information. The node identifier may correspond to a signature signed by the private key of the node. The method also includes sending each packet to one or more nodes associated with the second subchain. The method further includes, at the second subchain, monitoring the packets received by one or more of a plurality of nodes associated with the second subchain to determine if a consensus on request has been reached from the first subchain. The method further includes processing the identical message at the second subchain if a consensus on request has been reached from the first subchain.

[0014] Additional aspects of the method include constructing a packet at each of a plurality of nodes associated with the second subchain, and sending each packet to one or more nodes associated with the first subchain. The packet includes a message intended for a smart contract associated

with the first subchain and a node identifier. The messages constructed by each of the plurality of nodes are identical, and may correspond to one of a transaction request or a transaction reply or other information. The method further includes, at the first subchain, monitoring the packets received by one or more of a plurality of nodes associated with the first subchain to determine if a consensus on request has been reached from the second subchain; and, if a consensus on request has been reached from the second subchain, processing the identical message at the first subchain.

[0015] It is understood that other aspects of mechanisms, nodes, and methods will become readily apparent to those skilled in the art from the following detailed description, wherein various aspects are shown and described by way of illustration.

BRIEF DESCRIPTION OF THE DRAWINGS

[0016] Various aspects of apparatuses and methods will now be presented in the detailed description by way of example, and not by way of limitation, with reference to the accompanying drawings, wherein:

[0017] FIG. 1 is an illustration of a large-scale decentralized network, including a first group of nodes forming a first subchain operating in accordance with a first mechanism and a second group of nodes forming a second subchain operating in accordance with a second mechanism.

[0018] FIG. 2 is a block diagram of the first mechanism and the second mechanism of FIG. 1.

[0019] FIG. 3 is a flow diagram of communication between the first subchain and the second subchain of FIG. 1.

[0020] FIG. 4 is a flowchart of a method of communication between the first subchain and the second subchain of FIG. 1.

[0021] FIG. 5 is a flowchart of a method of maintaining current lists of nodes associated with the first subchain and the second subchain of FIG. 1.

[0022] FIG. 6 is a block diagram of an apparatus configured to implement the methods of FIGS. 3, 4 and 5.

DETAILED DESCRIPTION

[0023] FIG. 1 is an illustration of a peer-to-peer network **100** having a large number of distributed nodes **102** forming a large-scale decentralized network or system. The number of nodes **102** in the large-scale decentralized network **100** may be, for example, around 10,000. Nodes **102** within the large-scale decentralized network **100** are grouped into a first subchain **104** and a second subchain **106**. These groups of nodes **104**, **106** may be described as upper layers of the large-scale decentralized network **100**. Nodes outside of these groupings **104**, **106** represent the lower layer of the large-scale decentralized network **100**. While a large number of nodes **102** and subchains **104**, **106** may be present in a large-scale decentralized network, for ease of illustration, a reduced number of nodes and subchains are shown in FIG. 1.

[0024] The first subchain **104** represents a logical grouping of nodes **109** within the large-scale decentralized network **100**. The node grouping may be based on the needs of an application being run on the nodes **109** in the first subchain **104**. For example, in FIG. 1, a first mechanism **108** for executing blockchain transactions is deployed among a

group of nodes **109** in the first subchain **104**. The first mechanism **108** may be a smart contract deployed in the public blockchain system like Bitcoin and Ethereum, and the nodes **109** in the first subchain **104** may be coordinated to perform certain blockchain tasks through, for example, a consensus mechanism or protocol. The consensus protocol typically takes a round-robin or randomized approach, where each node **109** associated with the subchain **104** has equal weight to determine which node will generate the new, next block in the blockchain for the subchain. The nodes **109** associated with the subchain **104** could change over the time, with some nodes leaving the subchain and new ones joining.

[0025] In addition to executing blockchain transactions, the first mechanism **108** may include other mechanisms that implement a communication protocol between the first subchain **104** and the second subchain **106** that allows the nodes **109** of the first subchain to submit a message to the second subchain. The message may be, for example, a transaction request, a transaction reply, or a conveyer of information. To this end, and with reference to FIG. 2, the first mechanism **108** may include a processing mechanism **202**, a construction mechanism **204**, a sending mechanism **206**, and a cross-chain mechanism **208** with a nodelist mechanism **210**.

[0026] The processing mechanism **202** includes processing logic that executes blockchain transactions. The construction mechanism **204** includes construction logic that initiates construction of data packets by nodes **109** in the first subchain **104**. Each of these packets include a message intended for a remote smart contract associated with another subchain, such as the second subchain **106**, and an identifier of the node **109** that constructed the packet. The message may be a transaction request intended for processing by the remote smart contract or it may be a transaction reply indicating that a transaction request from the remote smart contract was executed. The sending mechanism **206** includes sending logic that causes each node **109** in the first subchain **104** that has constructed a packet to transmit the packet to the other subchain, e.g., the second subchain **106**.

[0027] The cross-chain mechanism **208** includes cross-chain logic that monitors packets received by the nodes **109** of the first subchain **104** to determine if a consensus on request has been reached. The nodelist mechanism **210** includes nodelist logic that maintains a current list of nodes **111** associated with other subchains, such as the second subchain **106**, within the large-scale decentralized network **100**. The list of nodes may be obtained from public information, such as the public wallet address of the other subchains, and updated as needed when the composition of the other subchain changes. As described further below, the cross-chain mechanism **208** uses the nodelist to determine if a consensus on request has been reached by the first subchain **104**. If a consensus corresponding to a transaction request has been reached, the first mechanism **108** executes the transaction in accordance with the processing logic of the processing mechanism **202**.

[0028] Like the first subchain **104**, the second subchain **106** represents a logical grouping of nodes **111** within the large-scale decentralized network **100**. The node grouping may be based on the needs of an application being run on the nodes **111** in the second subchain **106**. For example, in FIG. 1, a second mechanism **110** for executing blockchain transactions is deployed among a group of nodes **111** in the second subchain **106**. The second mechanism **110** may be a

smart contract deployed in the public blockchain system like Bitcoin and Ethereum, and the nodes **111** in the second subchain **106** may be coordinated to perform certain blockchain tasks through, for example, a consensus mechanism or protocol. The consensus protocol typically takes a round-robin approach, where each node **111** associated with the subchain **106** has equal weight to determine which node will generate the new, next block in the blockchain for the subchain. The nodes **111** associated with the subchain **106** could change over the time, with some nodes leaving the subchain and new ones joining.

[0029] In addition to executing blockchain transactions, the second mechanism **110** may include other mechanisms that implement a communication protocol between the second subchain **106** and the first subchain **104** that allows the nodes **111** of the second subchain to submit a message to the first subchain. The message may be, for example, a transaction request, a reply, or a conveyer of information. To this end, and with reference to FIG. 2, the second mechanism **110** may include a processing mechanism **212**, a construction mechanism **214**, a send mechanism **216**, and a cross-chain mechanism **218** with a nodelist mechanism **220**.

[0030] The processing mechanism **212** includes processing logic that executes blockchain transactions. The construction mechanism **214** includes construction logic that initiates construction of data packets by nodes **111** in the second subchain **106**. Each of these packets includes a message intended for a remote smart contract associated with another subchain, such as the first subchain **104**, and an identifier of the node **111** that constructed the packet. The message may be a transaction request intended for processing by the remote smart contract or it may be a transaction reply indicating that a transaction request from the remote smart contract was executed. The send mechanism **216** includes sending logic that causes each node **111** in the second subchain **106** that has constructed a packet to transmit the packet to the other subchain, e.g., the first subchain **104**.

[0031] The cross-chain mechanism **218** includes cross-chain logic that monitors packets received by the nodes **111** of the second subchain **106** to determine if a consensus on request has been reached. The nodelist mechanism **220** includes nodelist logic that maintains a current list of nodes **109** associated with other subchains, such as the first subchain **104**, within the large-scale decentralized network **100**. The list of nodes may be obtained from public information, such as the public wallet address of the other subchains, and updated as needed when the composition of the other subchain changes. As described further below, the cross-chain mechanism **218** uses the nodelist to determine if a consensus on request has been reached by the second subchain. If a consensus corresponding to a transaction request has been reached, the second mechanism **110** executes the transaction in accordance with the processing logic of the processing mechanism **212**.

[0032] Returning to FIG. 1, in one configuration, the lower layer of the large-scale decentralized network **100** includes nodes **102** that relay packets with messages from the nodes **109** in the first subchain **104** to one or more nodes **111** in the second subchain **106**. For example, each node **109** in the first subchain **104** may relay a packet to the second subchain **106** by sending its packet to a node **112** in the lower layer. The lower-layer node **112**, in turn, forwards the packet to a node **111** associated with the second subchain **106**. Each node **109**

in the first subchain **104** may send its packet to a unique one of the lower-layer nodes **112**. Alternatively, a group of nodes **109** in the first subchain **104** may send their packets to the same lower-layer node **112**. In another configuration, packets from nodes **109** in the first subchain **104** may be sent directly to nodes **111** associated with the second subchain **106**.

[0033] The nodes **109** within the first subchain **104** (operating in conjunction with the first mechanism **108**), together with the nodes **111** within the second subchain **106** (operating in conjunction with the second mechanism **110**), enable communication between the subchains **104**, **106** in a way that provides numerous benefits. These benefits include: 1) increased confidence in legitimate communications and transaction processing between the subchains based on the exchange of consensus requests, 2) prompt execution of communications and transaction processing between the subchains based on the exchange of consensus requests, and 3) elimination of the need to manually request communication by a single user with private key signature.

[0034] Having thus described the high level operation of nodes and mechanisms for facilitating efficient and confident communication between a first subchain **104** and a second subchain **106** in a decentralized network **100**, a more details description follows.

[0035] FIG. 3 is a flow diagram of communication between a first subchain **104** and a second subchain **106** in a decentralized network **100**. The flow diagram of FIG. 3 begins at a stage where a first mechanism **108** associated with the first subchain **104** desires to send a messages, e.g., a transaction request, to a second mechanism **110** associated with a second subchain **106**. The mechanisms **108**, **110** may be smart contracts, and in one configuration are configured to execute the same smart contract logic.

[0036] At operation **302**, a first smart contract **108** associated with the first subchain **104** executes local construct logic that initiate the construction of a data packet at each node **109-1** thru **109-n** that is associated with the first subchain **104**. The packet includes a message, e.g., a transaction request, requesting execution of a blockchain transaction by a second smart contract **110** associated with the second subchain **106**. In addition to the transaction request itself, the packet includes an target address that corresponds to the address of the second smart contract **110**, or more specifically the address of a node **111-1** thru **111-n** associated with the second subchain **106**, and an identifier of the node that is constructing the packet. The node identifier may be a signature corresponding to the private key of the node **109-1** thru **109-n**.

[0037] At operation **304**, the first smart contract **108** associated with the first subchain **104** executes sending logic that causes each node **109-1** thru **109-n** that has constructed a packet, to transmit its packet to one or more nodes **111-1** thru **111-n** associated with the second subchain **106**. As previously described, the packets may be relayed through underlying lower-layer nodes **102** (not shown in FIG. 3) or over a common blockchain (not shown), or they may be sent directly to the nodes **111-1** thru **111-n** associated with the second subchain **106**.

[0038] At operation **306**, a second smart contract **110** associated with the second subchain **106** executes cross-chain logic with respect to the messages received by the one or more nodes **111-1** thru **111-n** associated with the second subchain **106**. To this end, the second smart contract **110**

processes the received packets to determine if a consensus on request has been reached from the first subchain. To this end, the second smart contract **110** accesses a nodelist that identifies the nodes **109-1** thru **109-n** that are currently associated with the first subchain **104**, and determines that a consensus on request is reached when an identical message is received from a threshold number of nodes included in the nodelist.

[0039] For example, the second smart contract **110** executing cross-chain logic may: 1) identify messages that were received from a node **109-1** thru **109-n** included in the nodelist as first-subchain messages, 2) count the number of first-subchain messages that are identical, and 3) determine if the count satisfies a threshold criterion. If the threshold criterion is satisfied, the second smart contract **110** concludes that a consensus on request has been reached. The threshold criterion may correspond to a percentage of nodes **109-1** thru **109-n** in the first subchain **104**. For example, a criterion may be set at 51%, in which case the second smart contract **110** concludes a consensus on request has been reached when an identical message is received from 51% or more of the nodes **109-1** thru **109-n** in the nodelist.

[0040] At operation **308**, if a consensus on request has been reached at the second subchain **106**, the second smart contract **110** processes the identical message, i.e., the consensus message, that was received. For example, if the consensus message corresponds to a transaction request, the second smart contract **110** executes the consensus request in accordance with processing logic associated with the smart contract.

[0041] At operation **310**, the second smart contract **110** may begin to repeat the process in the other direction. For example, the second smart contract **110** may execute local construct logic that initiates the construction of a data packet at each node **111-1** thru **111-n** that is associated with the second subchain **106**. The packet may include a messages corresponding to a transaction request requesting execution of a blockchain transaction by a first smart contract **108** associated with the first subchain **104** or it may include a reply to the first subchain **104** informing that its transaction request was executed. In addition to the message, the packet includes a target address that corresponds to the address of the first smart contract **108**, or more specifically the address of a node **109-1** thru **109-n** associated with the first subchain **104**, and an identifier of the node that constructed the packet. The node identifier may be a signature corresponding to the private key of the node **111-1** thru **111-n**.

[0042] At operation **312**, the second smart contract **110** associated with the second subchain **106** executes sending logic that causes each node **111-1** thru **111-n** that has constructed a packet, to transmit its packet to one or more nodes **109-1** thru **109-n** associated with the first subchain **104**. As previously described, the packets may be relayed through underlying lower-layer nodes **102** (not shown in FIG. 3) or over a common blockchain (not shown), or they may be sent directly to the nodes **109-1** thru **109-n** associated with the first subchain **104**.

[0043] At operation **314**, a first smart contract **108** associated with the first subchain **104** executes cross-chain logic with respect to the message received by the one or more nodes **109-1** thru **109-n** associated with the first subchain **104**. To this end, the first smart contract **108** processes the received packets to determine if a consensus on request has been reached from the second subchain. To this end, the first

smart contract **108** accesses a nodelist that identifies the nodes **111-1** thru **111-n** that are currently associated with the second subchain **106**, and determines that a consensus on request is reached when an identical message is received from a threshold number of nodes included in the nodelist.

[0044] For example, the first smart contract **108** executing cross-chain logic may: 1) identify messages that were received from a node **111-1** thru **111-n** included in the nodelist as second-subchain messages, 2) count the number of second-subchain messages that are identical, and 3) determine if the count satisfies a threshold criterion. If the threshold criterion is satisfied, the first smart contract **108** concludes that a consensus on request has been reached. The threshold criterion may correspond to a percentage of nodes **111-1** thru **111-n** in the second subchain **106**. For example, a criterion may be set at 51%, in which case the first smart contract **108** concludes a consensus on request has been reached when an identical request is received from 51% or more of the nodes **111-1** thru **111-n** in the nodelist.

[0045] If a consensus on request has been reached at the first subchain **104**, the first smart contract **108** processes the identical message, i.e., the consensus message. For example, if the consensus message corresponds to a transaction request, the first smart contract **108** executes the consensus request in accordance with processing logic associated with the smart contract. If the consensus message corresponds to a transaction reply, the first smart contract **108** may process the reply and thereby be informed that a transaction request from the first subchain **104** to the second subchain **106** was successfully executed or not successfully executed, whichever the case may be.

[0046] FIG. 4 is a flowchart of an example method of communication between a first subchain **104** and a second subchain **106** in a decentralized network **100**. The method may be performed, for example, by the nodes **109** within the first subchain **104** (operating in conjunction with a first smart contract **108**), together with the nodes **111** within the second subchain **106** (operating in conjunction with a second smart contract **110**). In the example communication in the flowchart of FIG. 4, the direction of communication is from the first subchain **104** to the second subchain **106**, and then back from the second subchain to the first subchain.

[0047] At block **402**, the nodes **109** associated with the first subchain **104** operate in conjunction with the first smart contract **108** to construct, at each of a plurality of nodes associated with the first subchain, a packet including a message, e.g., a transaction request, intended for the second smart contract **110** associated with the second subchain **106**.

[0048] At block **404**, each of the nodes **109** associated with the first subchain **104** operates in conjunction with the first smart contract **108** to transmit its packet to one or more nodes **111** associated with the second subchain **106**.

[0049] At block **406**, one or more nodes **111** associated with the second subchain operate in accordance with the second smart contract **110** to monitor the packets and messages, e.g., transaction requests, included in the packets received by the nodes to determine if a consensus on request has been reached from the first subchain **104**. To this end, the second smart contract **110** accesses a nodelist that identifies the nodes **109-1** thru **109-n** that are currently associated with the first subchain **104**, and determine that a consensus on request is reached when an identical message, i.e., identical transaction request, is received from a threshold number of nodes included in the nodelist.

[0050] More specifically, the second smart contract **110** executing cross-chain logic may: 1) identify requests that were received from a node **109-1** thru **109-n** included in the nodelist as first-subchain requests, 2) count the number of first-subchain requests that are identical, and 3) determine if the count satisfies a threshold criterion. If the threshold criterion is satisfied, the second smart contract **110** concludes that a consensus on request has been reached. The threshold criterion may correspond to a percentage of nodes **109-1** thru **109-n** in the first subchain **104**. For example, a criterion may be set at 51%, in which case the second smart contract **110** concludes a consensus on request has been reached when an identical request is received from 51% or more of the nodes **109-1** thru **109-n** in the nodelist.

[0051] At block **408**, if a consensus on request is reached, the second smart contract **110** processes the identical message, i.e., the consensus message. For example, if the consensus message is a transaction request, the second smart contract **110** executes the transaction in accordance with transaction logic.

[0052] At block **410**, the nodes **111** associated with the second subchain **106** operate in conjunction with the second smart contract **110** to construct, at each of a plurality of nodes associated with the second subchain, a packet including a message, e.g., a transaction request, intended for the first smart contract **108** associated with the first subchain **104**. The message may be, for example, a confirmation that the consensus transaction request sent by the first subchain **104** was processed.

[0053] At block **412**, each of the nodes **111** associated with the second subchain **106** operates in conjunction with the second smart contract **110** to transmit its packet to one or more nodes **109** associated with the first subchain **104**.

[0054] At block **414**, one or more nodes **109** associated with the first subchain **104** operate in accordance with the first smart contract **108** to monitor the packets and messages included in the packets received by the nodes to determine if a consensus on request has been reached from the second subchain **106**. To this end, the first smart contract **108** accesses a nodelist that identifies the nodes **111-1** thru **111-n** that are currently associated with the second subchain **106**, and determine that a consensus on request is reached when an identical transaction request or identical message is received from a threshold number of nodes included in the nodelist.

[0055] More specifically, the first smart contract **108** executing cross-chain logic may: 1) identify requests/messages that were received from a node **111-1** thru **111-n** included in the nodelist as second-subchain requests/messages, 2) count the number of second-subchain requests/messages that are identical, and 3) determine if the count satisfies a threshold criterion. If the threshold criterion is satisfied, the first smart contract **108** concludes that a consensus on request has been reached. The threshold criterion may correspond to a percentage of nodes **111-1** thru **111-n** in the second subchain **106**. For example, a criterion may be set at 51%, in which case the first smart contract **108** concludes a consensus on request has been reached when an identical request or identical message is received from 51% or more of the nodes **111-1** thru **111-n** in the nodelist.

[0056] At block **416**, if a consensus on request is reached, the second smart contract **110** processes the identical message, i.e., the consensus message. For example, if the consensus message is a transaction request, the second smart

contract **110** executes the transaction in accordance with transaction logic. Or, if the consensus message is a confirmation of the processing of a prior transaction request, the second smart contract **110** processes the confirmation accordingly.

[0057] Returning to block **406**, if the second smart contract **110** determines that a consensus on request has not been reached, or the threshold criterion is not met within desired period of time, the second smart contract may proceed directly to blocks **410** and **412** to construct and send a message to the first subchain indicating that a consensus on request was not reached by the second subchain **106**. Likewise, at block **414**, if the first smart contract **108** determines that a consensus on request has not been reached, or the threshold criterion is not met within desired period of time, the first smart contract may proceed directly to blocks **402** and **404** to construct and send a message to the second subchain indicating that a threshold criterion was not met by the first subchain **104**.

[0058] Regarding the nodelists relied upon by the smart contracts in blocks **406** and **414**, FIG. **5** is a flowchart of a method of maintaining current nodelists among the subchains **104**, **106** so the first subchain knows the identities, e.g., public addresses, of the nodes associated with the second subchain and vis versa. As previously described, the makeup of the nodes **109**, **111** that are associated with a subchain may change—with current nodes leaving the subchain and new nodes joining the subchain. Accordingly, to accurately determine the existence of a consensus message, the nodelists referenced during the monitoring of received messages should be up to date. To this end, at block **502**, the nodelist for the first subchain **104** is initially determined based on the set of nodes forming the first subchain. For example, the creator or owner of the first subchain **104** may determine the initial set nodes in the subchain and create an initial nodelist. At block **504**, the first subchain **104** informs the second subchain **106** of the initial nodelist. At block **506**, a node leaves or joins the first subchain **104**, thereby changing the node set forming the first subchain. At block **508**, the first subchain **104** informs the second subchain **106** of the change.

[0059] In blocks **504** and **508**, the first subchain **104** may inform the second subchain **106** of the nodelist or nodelist change in accordance with the cross-chain logic described above. For example, the nodes **109** associated with the first subchain **104** may construct and send packets that includes messages corresponding to the initial nodelist, a node list change, or an updated nodelist to the second subchain **106**. The second subchain **106** may process the packets to determine if a consensus on request has been reached, and process the consensus message to obtain the initial nodelist, the node list change, or updated nodelist.

[0060] FIG. **6** is a schematic block diagram of an apparatus **600**. The apparatus **600** may correspond to one or more nodes configured to enable the method of communication between a first subchain **104** and a second subchain **106** in a decentralized network **100**, as described above with reference to FIGS. **3**, **4** and **5**. The apparatus may be, for example, a node **109** within the first subchain **104** or a node **111** within the second subchain **106**.

[0061] The apparatus **600** may include one or more processors **602** configured to access and execute computer-executable instructions stored in at least one memory **604**. The processor **602** may be implemented as appropriate in

hardware, software, firmware, or combinations thereof. Software or firmware implementations of the processor **602** may include computer-executable or machine-executable instructions written in any suitable programming language to perform the various functions described herein. The processor **602** may include, without limitation, a central processing unit (CPU), a digital signal processor (DSP), a reduced instruction set computer (RISC) processor, a complex instruction set computer (CISC) processor, a microprocessor, a microcontroller, a field programmable gate array (FPGA), a System-on-a-Chip (SOC), or any combination thereof. The apparatus **600** may also include a chipset (not shown) for controlling communications between the processor **602** and one or more of the other components of the apparatus **600**. The processor **602** may also include one or more application-specific integrated circuits (ASICs) or application-specific standard products (ASSPs) for handling specific data processing functions or tasks.

[0062] The memory **604** may include, but is not limited to, random access memory (RAM), flash RAM, magnetic media storage, optical media storage, and so forth. The memory **604** may include volatile memory configured to store information when supplied with power and/or non-volatile memory configured to store information even when not supplied with power. The memory **604** may store various program modules, application programs, and so forth that may include computer-executable instructions that upon execution by the processor **602** may cause various operations to be performed. The memory **604** may further store a variety of data manipulated and/or generated during execution of computer-executable instructions by the processor **602**.

[0063] The apparatus **600** may further include one or more network interfaces **606** that may facilitate communication between the apparatus **600** and one or more other nodes using any suitable communications standard. For example, a LAN interface may implement protocols and/or algorithms that comply with various communication standards of the Institute of Electrical and Electronics Engineers (IEEE), such as IEEE 802.11, while a cellular network interface implement protocols and/or algorithms that comply with various communication standards of the Third Generation Partnership Project (3GPP) and 3GPP2, such as 3G and 4G (Long Term Evolution), and of the Next Generation Mobile Networks (NGMN) Alliance, such as 5G.

[0064] The memory **604** may store various program modules, application programs, and so forth that may include computer-executable instructions that upon execution by the processor **602** may cause various operations to be performed. For example, the memory **604** may include an operating system module (O/S) **608** that may be configured to manage hardware resources such as the network interface **606** and provide various services to applications executing on the apparatus **600**.

[0065] The memory **604** stores additional program modules such as a processing module **610**, a construction module **612**, a sending module **614**, a cross-chain module **616** and a nodelist module **618**, each of which includes functions in the form of logic and rules that support and enable the method of communication between a first subchain **104** and a second subchain **106** in a decentralized network **100**, as described above with reference to FIGS. **3**, **4** and **5**. Although illustrated as separate modules in FIG. **6**, one or more of the modules may be a part of or a submodule of another module.

For example, as shown in FIG. 2, the nodelist module 618 may be a submodule of the cross-chain module 616. Each of the transaction module 610, the construction module 612, the sending module 614, the cross-chain module 616 and the nodelist module 618 includes computer-executable instructions that when executed by the processor 602 cause various operations to be performed, such as the operations described above with respect to FIGS. 3, 4 and 5.

[0066] The apparatus 600 and modules 610, 612, 614, 616, 618 disclosed herein may be implemented in hardware or software that is executed on a hardware platform. The hardware or hardware platform may be a general purpose processor, a digital signal processor (DSP), an application specific integrated circuit (ASIC), a field programmable gate array (FPGA) or other programmable logic component, discrete gate or transistor logic, discrete hardware components, or any combination thereof, or any other suitable component designed to perform the functions described herein. A general-purpose processor may be a microprocessor, but in the alternative, the processor may be any conventional processor, controller, microcontroller, or state machine. A processor may also be implemented as a combination of computing components, e.g., a combination of a DSP and a microprocessor, a plurality of microprocessors, one or more microprocessors in conjunction with a DSP, or any other such configuration.

[0067] Software shall be construed broadly to mean instructions, instruction sets, code, code segments, program code, programs, subprograms, software modules, applications, software applications, software packages, routines, subroutines, objects, executables, threads of execution, procedures, functions, etc., whether referred to as software, firmware, middleware, microcode, hardware description language, or otherwise. The software may reside on a computer-readable medium. A computer-readable medium may include, by way of example, a smart card, a flash memory device (e.g., card, stick, key drive), random access memory (RAM), read only memory (ROM), programmable ROM (PROM), erasable PROM (EPROM), electrically erasable PROM (EEPROM), a general register, or any other suitable non-transitory medium for storing software.

[0068] The various aspects of this disclosure are provided to enable one of ordinary skill in the art to practice the present invention. Various modifications to exemplary embodiments presented throughout this disclosure will be readily apparent to those skilled in the art. Thus, the claims are not intended to be limited to the various aspects of this disclosure, but are to be accorded the full scope consistent with the language of the claims. All structural and functional equivalents to the various components of the exemplary embodiments described throughout this disclosure that are known or later come to be known to those of ordinary skill in the art are expressly incorporated herein by reference and are intended to be encompassed by the claims. No claim element is to be construed under the provisions of 35 U.S.C. § 112, sixth paragraph, unless the element is expressly recited using the phrase “means for” or, in the case of a method claim, the element is recited using the phrase “step for.”

What is claimed is:

1. A mechanism for facilitating communication between a first subchain and a second subchain in a decentralized network, the mechanism comprising:

- a construction mechanism including construction logic that initiates at each of a plurality of nodes associated with the first subchain, a construction of a packet including a message intended for a smart contract associated with the second subchain and a node identifier, where the messages constructed by the plurality of nodes are identical; and
 - a sending mechanism including sending logic that causes each node that has constructed a packet, to transmit its packet to one or more nodes associated with the second subchain.
2. The mechanism of claim 1, wherein the message corresponds to one of a transaction request or a transaction reply.
 3. The mechanism of claim 1, wherein the node identifier corresponds to a signature signed by the private key of the node.
 4. The mechanism of claim 1, further comprising a cross-chain mechanism including cross-chain logic that monitors packets received by one or more of the plurality of nodes associated with the first subchain to determine if a consensus on request has been reached from another subchain, which other subchain may correspond to the second subchain or a third subchain different from the second subchain.
 5. The mechanism of claim 4, wherein the cross-chain mechanism further includes nodelist logic that accesses a nodelist that includes node identifiers for a plurality of nodes associated with the other subchain, and wherein the cross-chain logic is configured to determine that a consensus on request is reached when an identical message has been received from a threshold measure of nodes identified in the nodelist.
 6. The mechanism of claim 5, wherein the threshold measure corresponds to a percentage of the total number of nodes identified in the nodelist.
 7. The mechanism of claim 6, wherein the nodelist logic is configured to receive information relating to the nodes associated with the other subchain and to update the nodelist accordingly.
 8. The mechanism of claim 4, further comprising a processing mechanism including processing logic that processes the message if a consensus on request has been reached from the other subchain.
 9. A smart contract embodied in at least one of a plurality of nodes associated with a first subchain, the smart contract comprising logic that:
 - causes each of the plurality of nodes associated with the first subchain to construct a packet including a message intended for a smart contract associated with a second subchain and a node identifier, where the messages constructed by the plurality of nodes are identical; and
 - causes each of the plurality of nodes to transmit its packet to one or more nodes associated with the second subchain.
 10. The smart contract of claim 9, further comprising cross-chain logic that monitors packets received by one or more of the plurality of nodes associated with the first subchain to determine if a consensus on request has been reached from another subchain, which other subchain may correspond to the second subchain or a third subchain different from the second subchain.
 11. The smart contract of claim 10, wherein the cross-chain logic includes nodelist logic that obtains a nodelist that

includes node identifiers for a plurality of nodes associated with the other subchain, and a consensus on request is determined to have been reached when an identical message has been received from a threshold measure of nodes included in the nodelist.

12. The smart contract of claim **11**, wherein the nodelist logic that obtains the nodelist is configured to receive information relating to the nodes associated with the other subchain and to update the nodelist accordingly.

13. An apparatus for facilitating communication between a first subchain and a second subchain in a decentralized network, the apparatus comprising:

a network interface;

a memory having smart contract logic; and

a processor coupled to the network interface and the memory and configured to execute the smart contract logic to:

cause each of a plurality of nodes associated with the first subchain to construct a packet including a message intended for a smart contract associated with the second subchain and a node identifier, where the messages constructed by the plurality of nodes are identical; and

cause each of the plurality of nodes to transmit its packet to one or more nodes associated with the second subchain.

14. The apparatus of claim **13**, wherein the processor is further configured to execute the smart contract logic to monitor packets received by one or more of the plurality of nodes associated with the first subchain to determine if a consensus on request has been reached from a another subchain, which other subchain may correspond to the second subchain or a third subchain different from the second subchain.

15. The apparatus of claim **14**, wherein the processor is further configured to execute the smart contract logic to obtain a nodelist that includes node identifiers for a plurality of nodes associated with the other subchain, and wherein a consensus on request is determined to have been reached when an identical message has been received from a threshold measure of nodes identified in the nodelist.

16. The apparatus of claim **15**, wherein the smart contract logic that obtains the nodelist is configured to receive information relating to the nodes associated with the other subchain and to update the nodelist accordingly.

17. A method of communication between a first subchain and a second subchain in a decentralized network, the method comprising:

constructing at each of a plurality of nodes associated with the first subchain, a packet including a message intended for a smart contract associated with the second subchain and a node identifier, where the messages constructed by the plurality of nodes are an identical message;

sending each packet to one or more nodes associated with the second subchain; and

at the second subchain, monitoring the packets received by one or more of a plurality of nodes associated with the second subchain to determine if a consensus on request has been reached from the first subchain.

18. The method of claim **17**, further comprising, if a consensus on request has been reached from the first subchain, processing the identical message at the second subchain.

19. The method of claim **17**, further comprising:

constructing at each of a plurality of nodes associated with the second subchain, a packet including a message intended for a smart contract associated with the first subchain and a node identifier where the messages constructed by the plurality of nodes are an identical message;

sending each packet to one or more nodes associated with the first subchain; and

at the first subchain, monitoring the packets received by one or more of a plurality of nodes associated with the first subchain to determine if a consensus on request has been reached from the second subchain.

20. The method of claim **19**, further comprising, if a consensus on request has been reached from the second subchain, processing the identical message at the first subchain.

* * * * *