



(19) **United States**

(12) **Patent Application Publication**
Fisher et al.

(10) **Pub. No.: US 2019/0169836 A1**

(43) **Pub. Date: Jun. 6, 2019**

(54) **STACKABLE EXPANSION JOINT FRAME ASSEMBLY**

(52) **U.S. Cl.**
CPC *E04B 1/6807* (2013.01); *E04B 2103/04* (2013.01); *E04B 5/36* (2013.01); *E04B 1/6813* (2013.01)

(71) Applicant: **InPro Corporation**, Muskego, WI (US)

(72) Inventors: **George Matthew Fisher**, New Berlin, WI (US); **Joel M. Gavlitto**, Waterford, WI (US)

(57) **ABSTRACT**

(21) Appl. No.: **15/831,013**

(22) Filed: **Dec. 4, 2017**

A system for attaching a flexible expansion joint to the surface of a building such as the floor of a building. The system for attaching the joint is configured to secure the joint and provide, in effect, a form up to which a top coat of material such as concrete or asphalt can be applied over an existing floor structure. The system provides a universal base unit upon which common extension units can be attached and stacked to vary the height of the form for the surface coat.

Publication Classification

(51) **Int. Cl.**
E04B 1/68 (2006.01)
E04B 5/36 (2006.01)

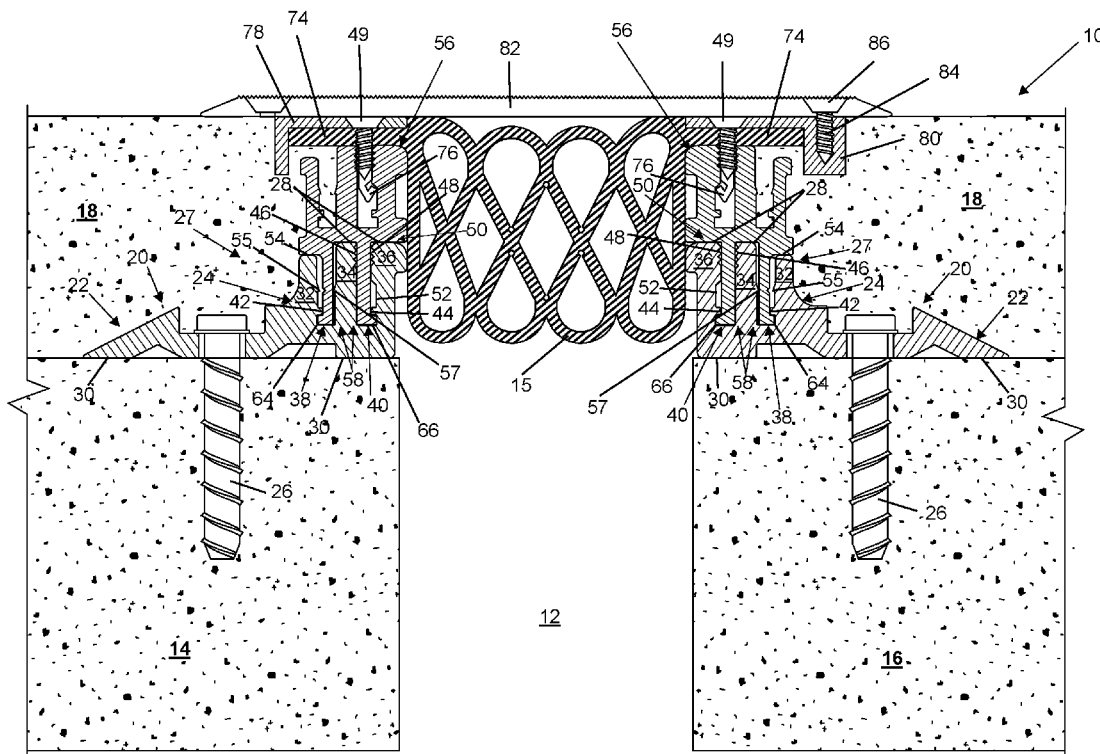

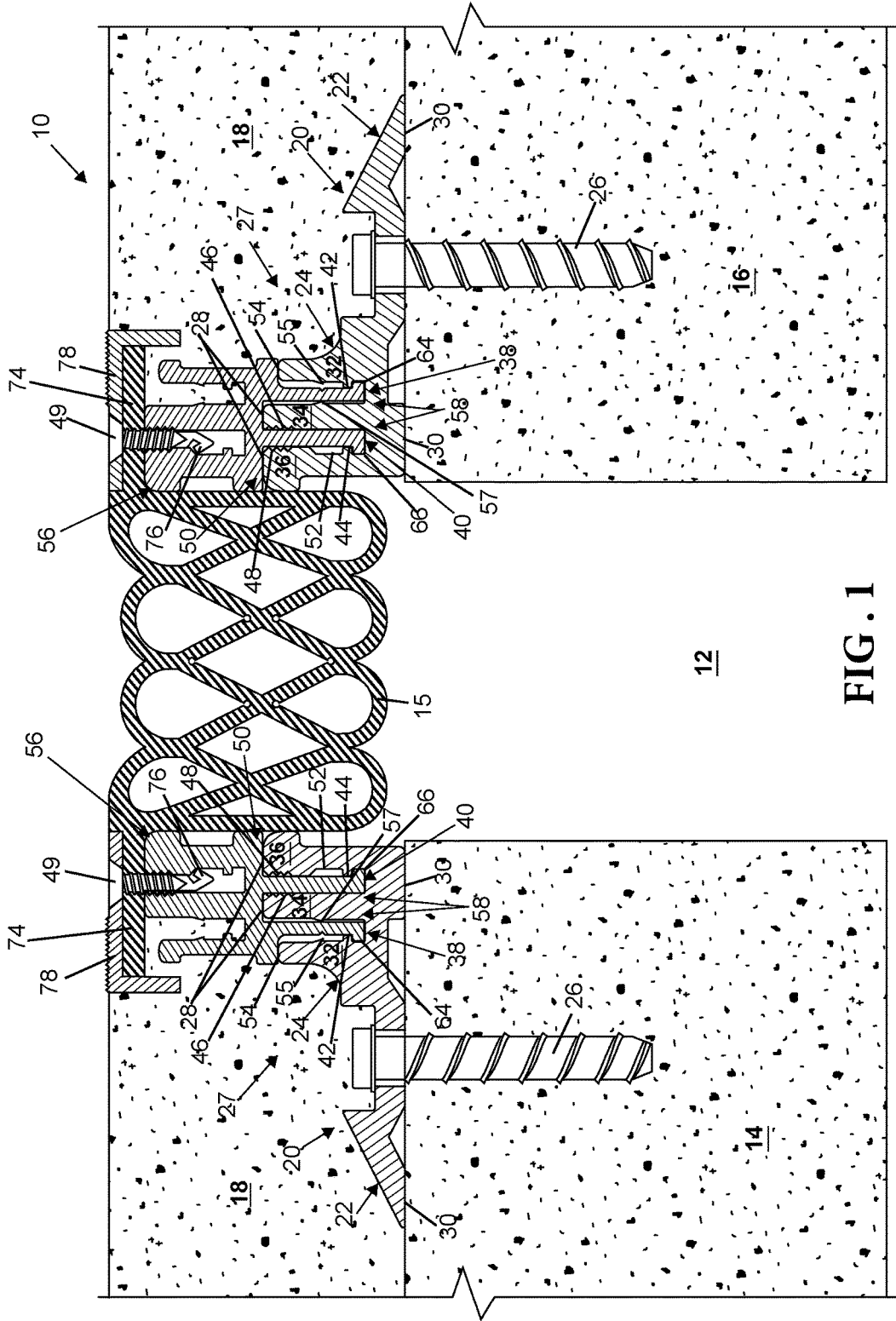

FIG. 1

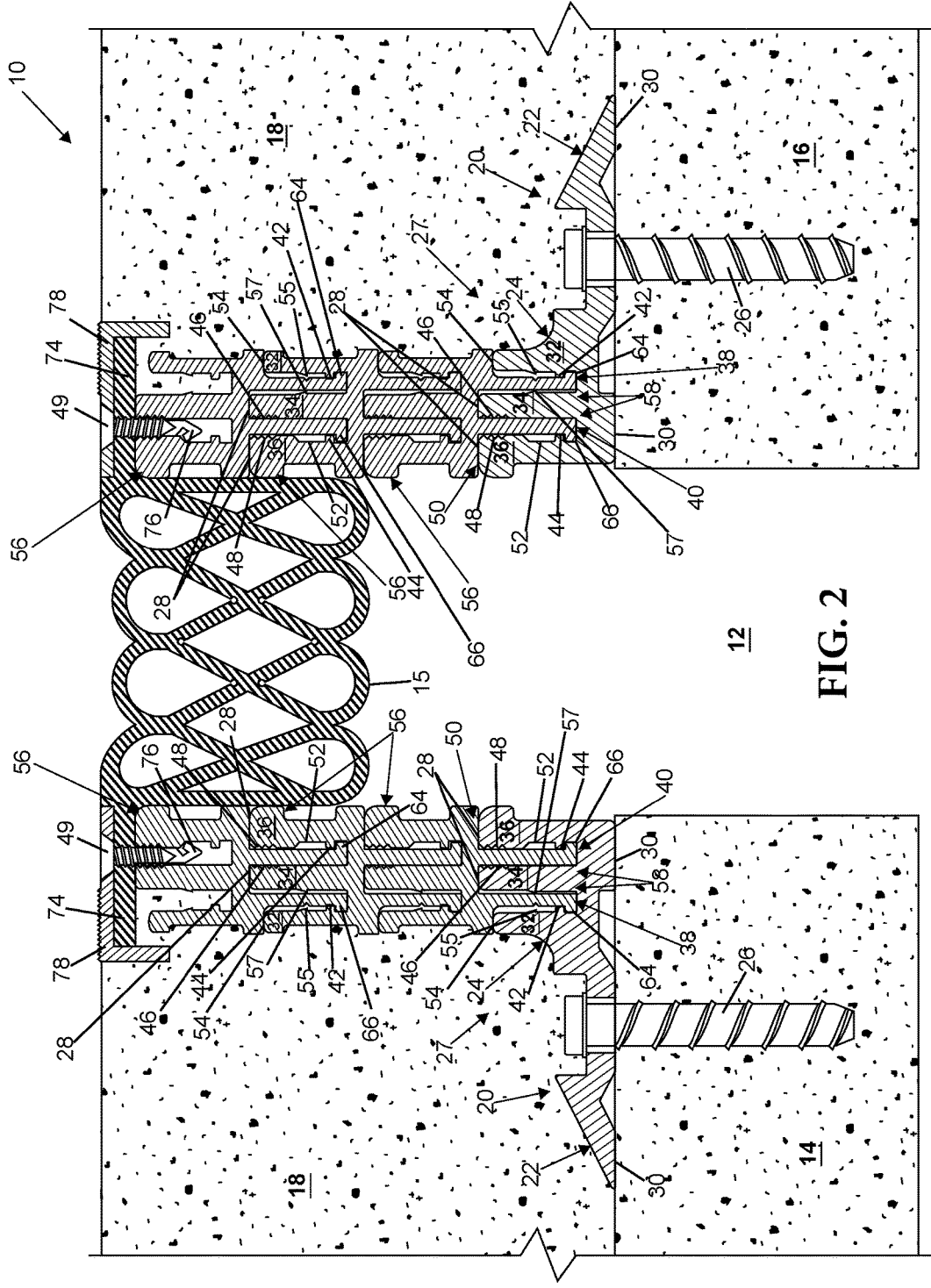

FIG. 2

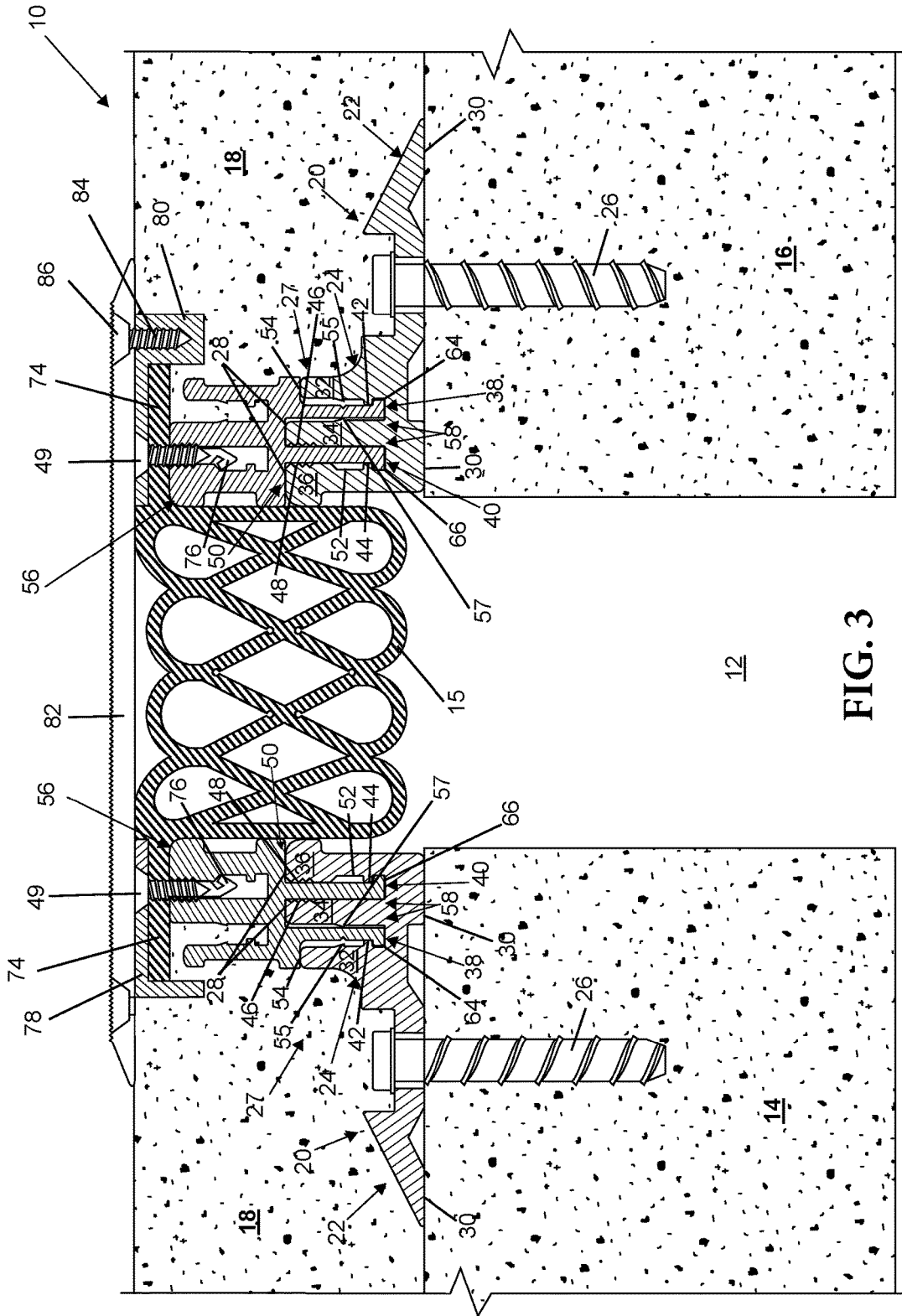

FIG. 3

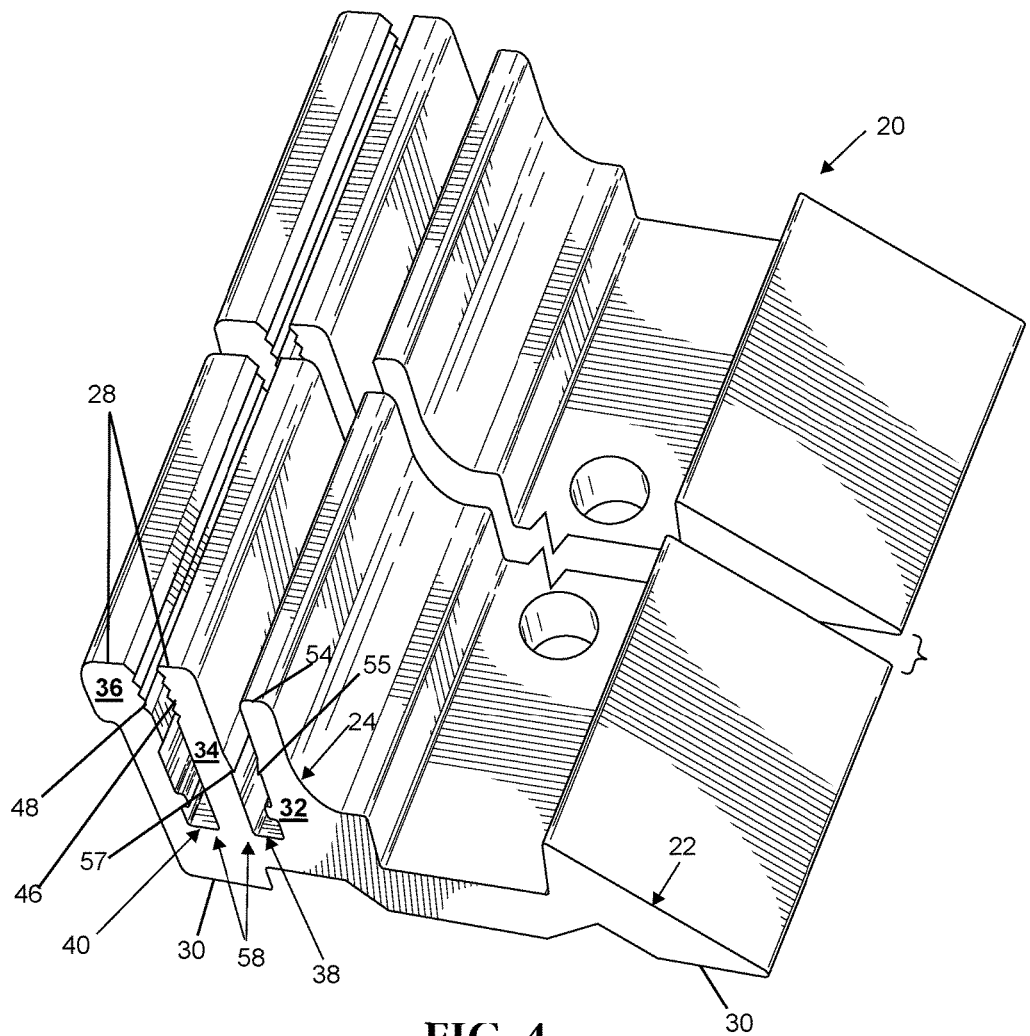

FIG. 4

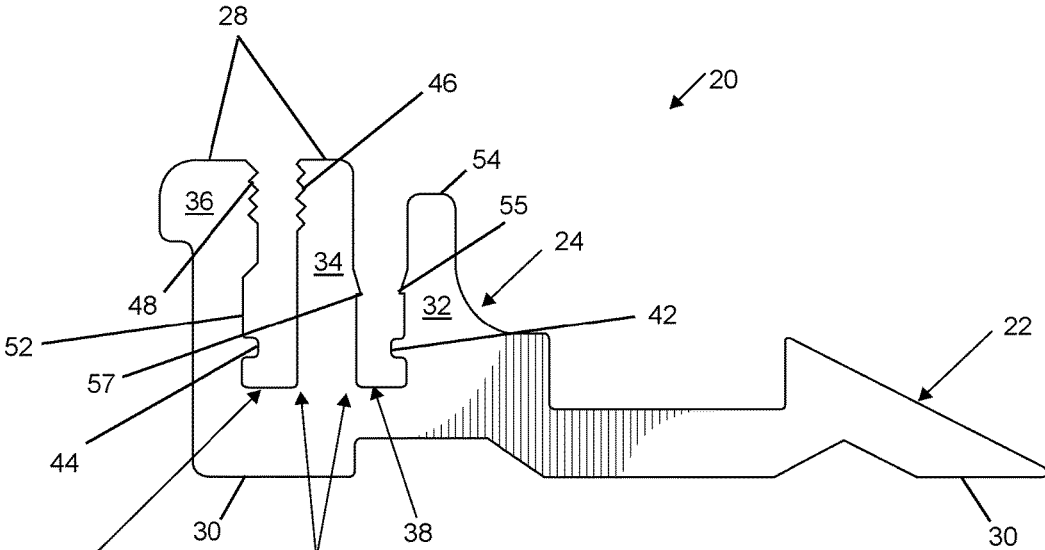

FIG. 5

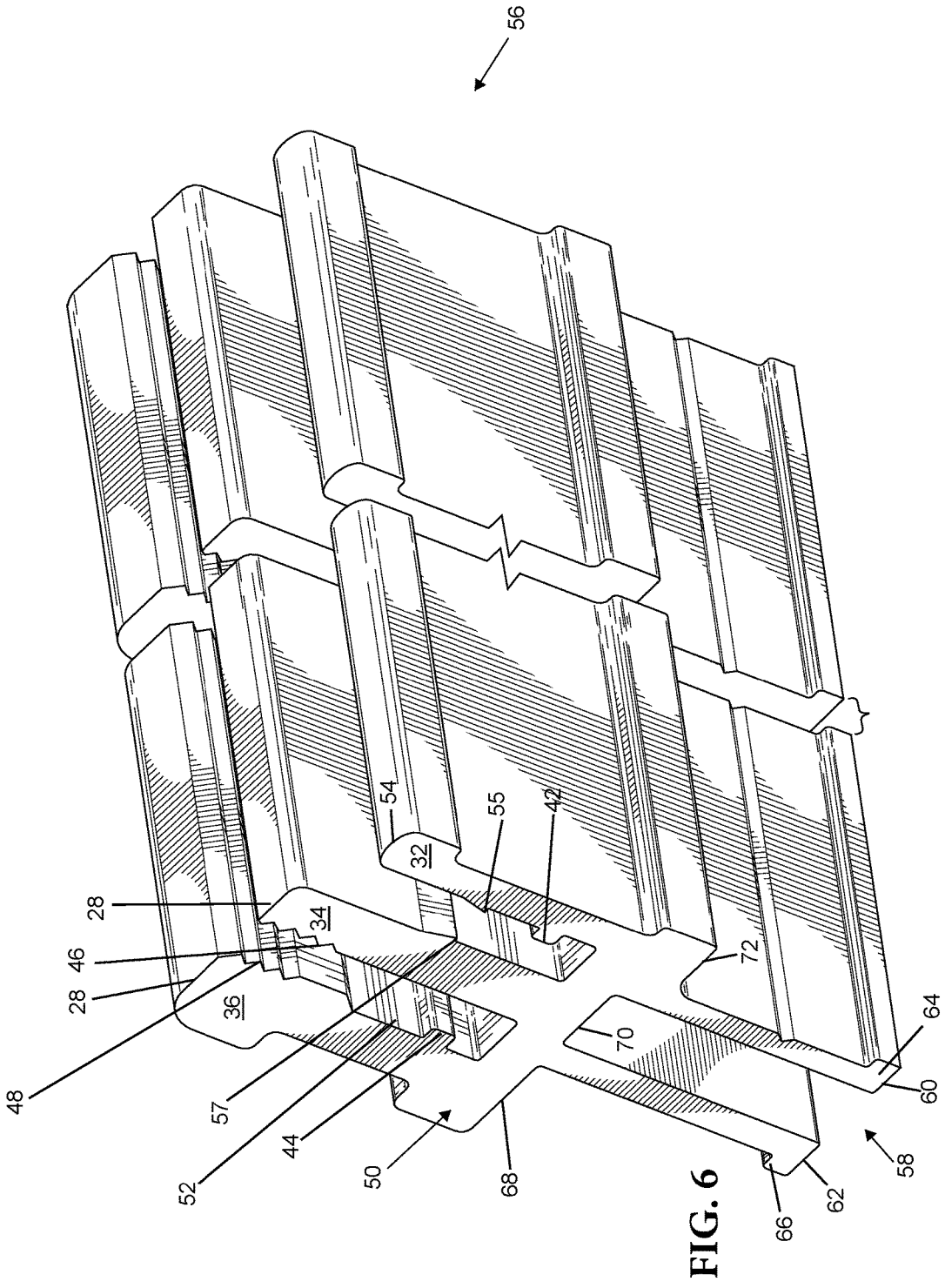

FIG. 6

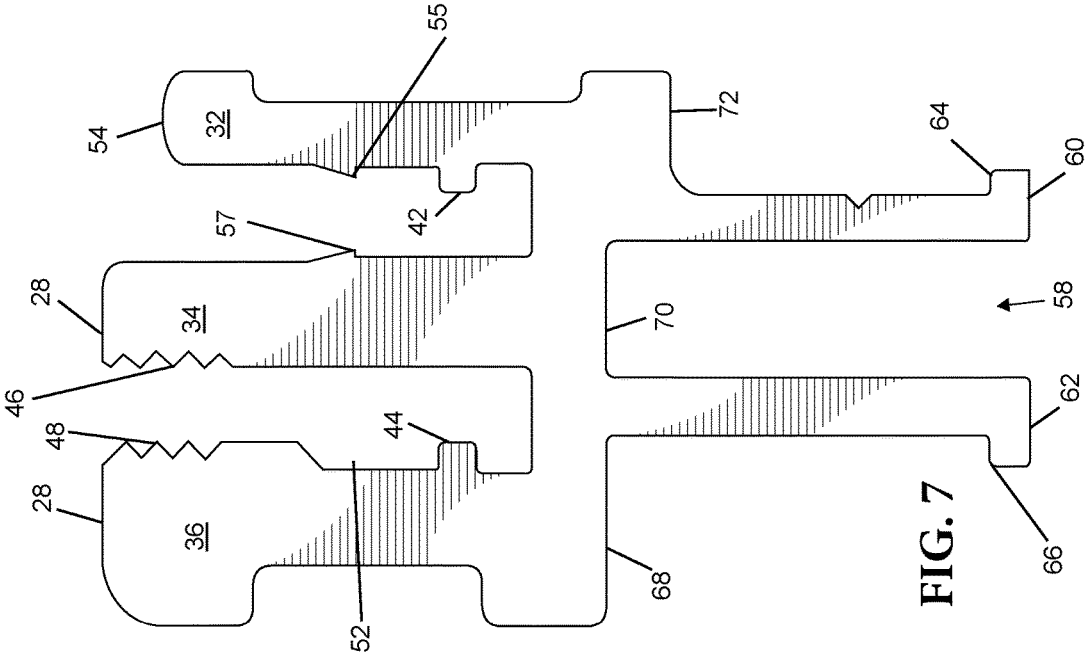

FIG. 7

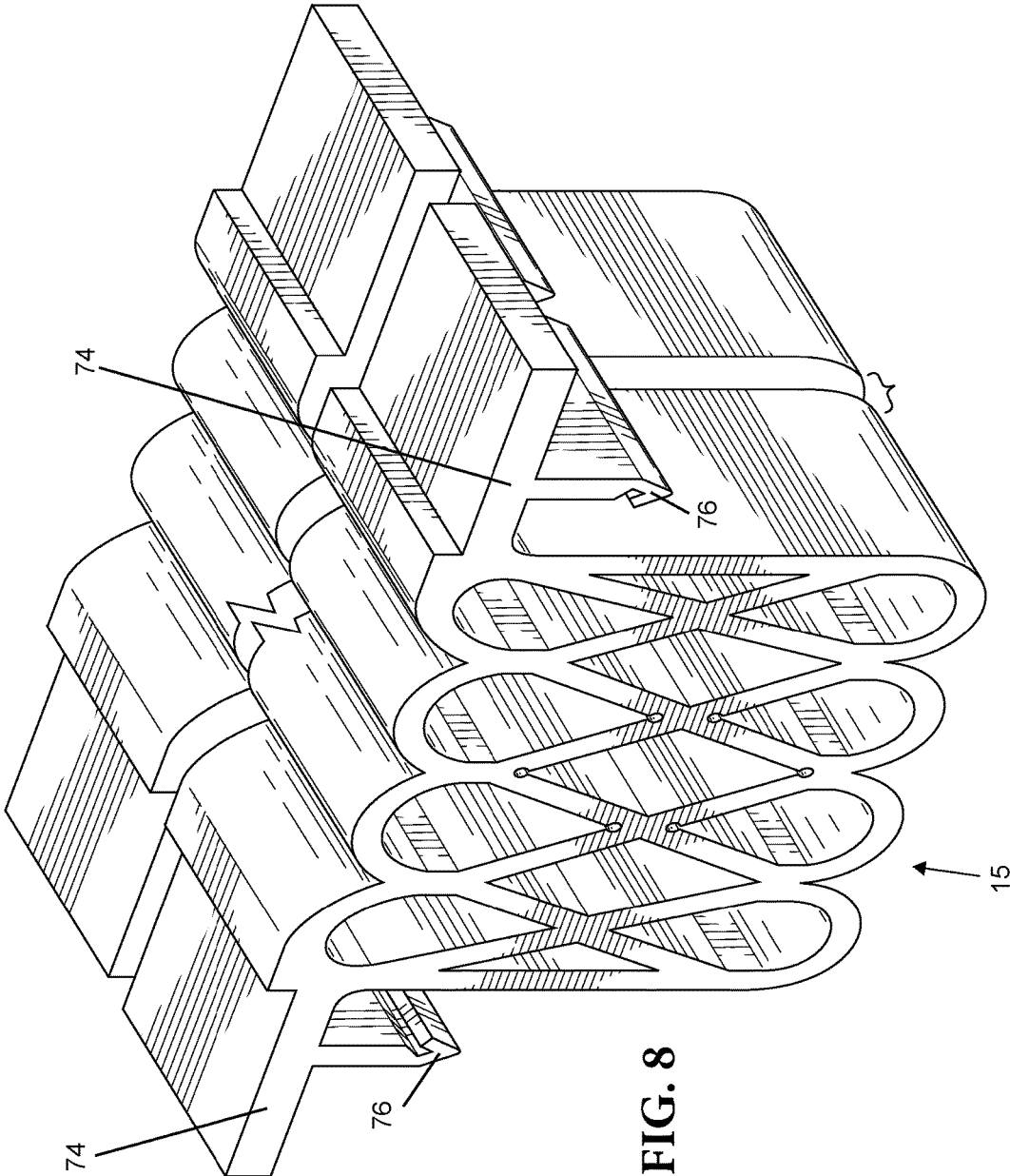

FIG. 8

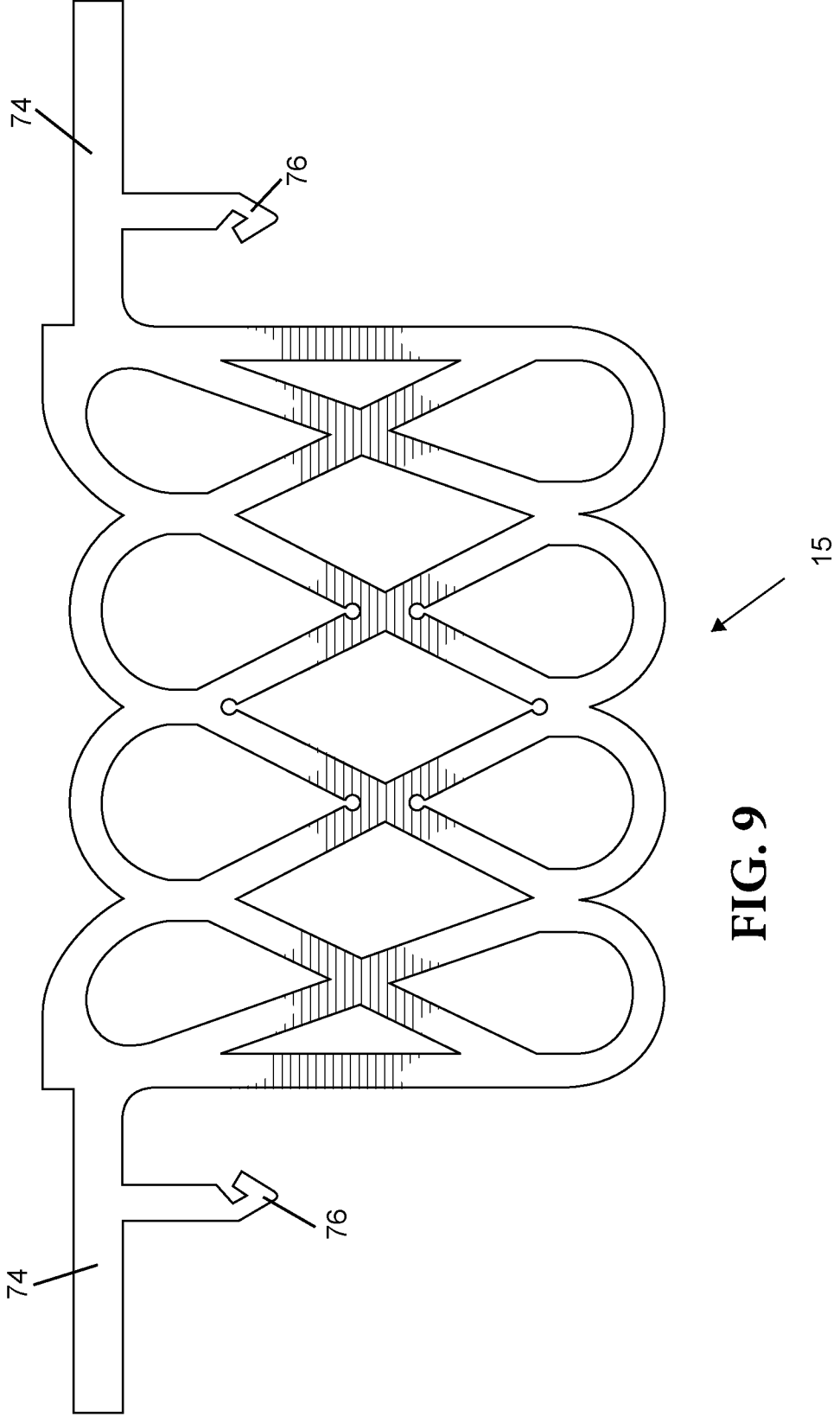

FIG. 9

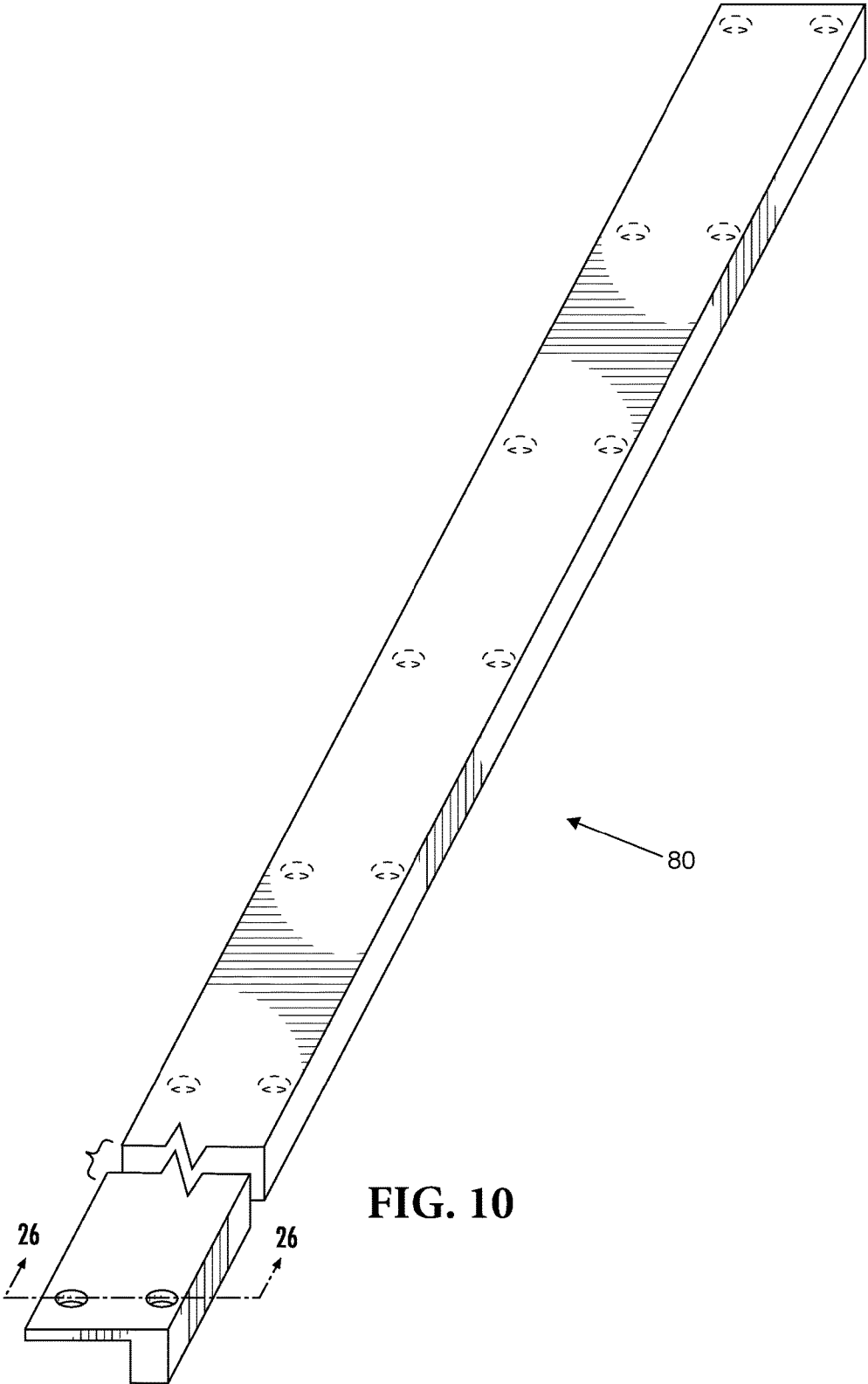

FIG. 10

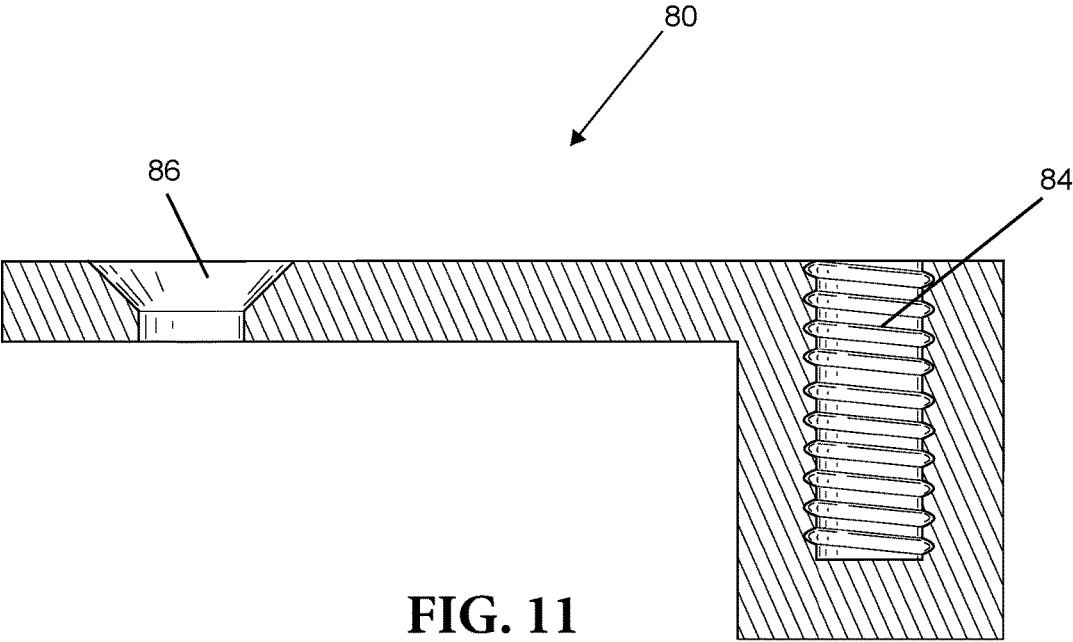

FIG. 11

STACKABLE EXPANSION JOINT FRAME ASSEMBLY

BACKGROUND OF THE INVENTION

[0001] The present invention relates to a system for attaching a flexible expansion joint to the surface of a building such as the floor or roof of a building. In particular, the system for attaching the joint is configured to secure the joint and provide, in effect, a form up to which a top coat of material such as concrete or asphalt can be applied over an existing structure. The system provides a universal base unit upon which common extension units can be attached and stacked to vary the height of the form for the surface coat.

SUMMARY OF THE INVENTION

[0002] One embodiment provides for an adjustable height expansion joint assembly for bridging an expansion gap in a floor or roof. The assembly is attachable to the surfaces of the floor or roof adjacent to the gap. The assembly includes a pair of elongated base supports each including a flange which provides an attachment to a respective surface, and a first interface having a first attachment configuration. Each flange includes a lower surface which rests against and is parallel to a respective surface, with the first interface being displaced from and generally parallel to the lower surface. The assembly further includes at least a pair of elongated extension members each having a first side including a second interface which includes a second attachment configuration which mates with the first interface to join the elongated extension member to the elongated base support. Each elongated extension member also includes a second side opposite to and generally parallel with the first side, with the second side including a third interface having the first attachment configuration. An elongated expansion joint including a pair of flanges is attachable to a respective third interfaces to bridge a gap between the surfaces.

[0003] Another embodiment provides for an assembly for forming the edge of a top coating applied to a floor or roof. The assembly is attachable to a surface at the edge of the floor or roof adjacent to an expansion gap and is configured to support one side of an elongated expansion joint which bridges the expansion gap. The assembly includes an elongated base support including a flange which provides an attachment to a respective surface, and a first interface having a first attachment configuration. The flange includes a lower surface which rests against and is parallel to a respective surface, with the first interface being displaced from and generally parallel to the lower surface at a first distance. The assembly further includes a first elongated extension member having a first side including a second interface which includes a second attachment configuration mated with the first interface to join the elongated extension member to the elongated base support. The elongated extension member includes a second side displaced at a second distance from, opposite to and generally parallel with the first side, with the second side including a third interface having the first attachment configuration. This assembly provides the top coating with a thickness defined by the sum of at least the first and second distances, wherein one side of the expansion joint is attached to the third interface.

[0004] Another embodiment provides for a method for bridging an expansion gap in a floor or roof and forming the edge for a top coating applied to the surface of a respective

floor or roof. The method includes the steps of attaching a flange of an elongated base support to the surface, with the base support having a first interface having a first attachment configuration, the first interface being displaced from and generally parallel to the lower surface at a first distance. The method further includes the step of attaching at least a first elongated extension members to the elongated base, with the elongated extension member having a first side including a second interface which includes a second attachment configuration engaged with the first interface. The elongated extension member also includes a second side displaced at a second distance from, opposite to and generally parallel with the first side, with the second side including a third interface having the first attachment configuration. The method also includes attaching one side of an expansion joint to the third interface, with the top coating having a thickness defined by at least the sum of the first and second distances.

BRIEF DESCRIPTION OF THE DRAWINGS

[0005] This application will become more fully understood from the following detailed description, taken in conjunction with the accompanying figures, wherein like reference numerals refer to like elements in which:

[0006] FIG. 1 is an end view of an adjustable height expansion joint assembly;

[0007] FIG. 2 is an end view of an adjustable height expansion joint assembly which has been expanded to increase the height of the assembly;

[0008] FIG. 3 is an end view of an alternative embodiment of the adjustable height expansion joint assembly which includes a cover plate;

[0009] FIG. 4 is a top perspective view of a base support;

[0010] FIG. 5 is an end view of the base support;

[0011] FIG. 6 is a top perspective view of an extension member;

[0012] FIG. 7 is an end view of the extension member;

[0013] FIG. 8 is a top perspective view of an expansion joint;

[0014] FIG. 9 is an end view of the expansion joint;

[0015] FIG. 10 is a top perspective view of an angle member; and

[0016] FIG. 11 is a cross-sectional view of the angle member of FIG. 10, taken along line 26-26.

DETAILED DESCRIPTION

[0017] Before turning to the figures, which illustrate the exemplary embodiments in detail, it should be understood that the present application is not limited to the details or methodology set forth in the description or illustrated in the figures. It should also be understood that the terminology is for the purpose of description only and should not be regarded as limiting.

[0018] Referring to FIG. 1, an adjustable height expansion joint assembly 10 for bridging an expansion gap 12 in a floor or roof is shown. FIG. 1 is an end view of the assembly 10 and illustrates one embodiment of the shapes of the components of the assembly 10. The majority of the components are elongated sections which are preferably extruded and/or extrusion molded. The assembly 10 is shown attached to 2 concrete floor sections 14 and 16 which are separated by the expansion gap 12. The assembly 10 supports an elastic joint 15 above or partially within gap 12 (depends upon particular

configuration of joint 15 and stacking as discussed below) between sections 14 and 16 and can be used to provide a variable width form for a top coat 18 applied to sections 14 and 16 after assembly 10 is installed. The thickness of the top coat 18 at the assembly 10 is defined by the total height of assembly 10 which can be varied as discussed in further detail below.

[0019] Assembly 10 includes a pair of elongated bases supports 20. Base supports 20 are made from an extruded material which in the preferred embodiment is an extruded aluminum. As shown in FIG. 1, the support 20 resting upon its respective floor section 16 is rotated 180 degrees from the support 20 resting upon floor section 14. Supports 20 include a flange 22, which extends from the body 24 of support 20. Flanges 22 are fastened to the respective floor sections 14 and 16 by a plurality of concrete screws 26 spaced along the length of the respective supports 20 (e.g. every 12 to 24 inches).

[0020] The body 24 includes a first interface 27 having, by way of example, an attachment configuration as shown in FIGS. 1 and 2. The top surfaces 28 are generally parallel with the bottom surfaces 30 of flange 22. In a preferred embodiment body 24 includes at least 3 elongated walls 32, 34 and 36 which are positioned as shown to define a pair of parallel channels 38 and 40 which extend the length of support 20. Each channel 38, 40 includes an engagement flange 42, 44 defined by the respective wall 32, 36. The flanges 42 and 44 may face opposite directions as shown. Walls 34 and 36 also include a plurality of opposed notches or teeth 46, 48 which cooperate to provide a location into which a threaded screw 49 can be engaged. Wall 36 also includes a channel 52. Walls 32 and 34 include respective opposed prongs 55 and 57. The top of walls 34 and 36 are bounded by surfaces 28, and the top of wall 32 is bounded by surface 54 which is parallel to surfaces 28, but offset therefrom. The walls 32, 34 and 36 provide an engagement location 50.

[0021] Located upon and engaged to respective bodies 24 are extension members 56. As shown in FIG. 1, the extension members 56 are rotated 180 degrees when located upon and engaged with their respective bodies 24. Each extension member 56 includes a top engagement formation which has the same configuration as engagement formation 50 and (referring to FIGS. 12-15) each element thereof is numbered with the same number as the engagement formation 50 for bodies 24.

[0022] Extension members 56 also include a bottom interface 58 which interfaces with channels 38 and 40 to hold members 56 in engagement with respective bodies 24. Referring to FIGS. 6 and 7, each interface includes a pair of elongated extension members 60 and 62 which each include an attachment configuration such as a tab/prong 64, 66. In the preferred embodiment the respective tabs 66, 64 are located at the ends of members 60 and 62 to oppose each other. This configuration allows members 60 and 62 to be flexed toward each other when an extension member 56 is engaged with a respective body 24 and, upon full engagement, have tabs 64 and 66 forced/biased into the respective flanges 42 and 44 as shown in FIG. 1. When fully engaged, surfaces 68, 70 and 72 of interface 58 rest upon the respective surfaces 28 and surface 54.

[0023] Elongated elastic expansion joint 15 is configured as shown and includes pair of flanges 74 which each may include a hook member 76. Depending upon the height

chosen for assembly 10 (as discussed in further detail below in reference to FIG. 2) hook members 76 will engage the teeth/notches 46 and channels 52 in walls 36 of an engagement formation 50 of either a body 24 or an extension member 56 stacked upon and engaged with a body 24. This interaction of members 76, notches 46 and channels 52 located and, at least partially, hold joint 15 in place. In addition, an angle member 78 may be located to capture and hold flanges 74 in engagement with a respective body 24 or member 56. Screws 49 are engaged with respective teeth 46, 48 to hold members 78 in place.

[0024] An example of a joint 15 and portions thereof are described in detail in U.S. Pat. No. 9,494,235, the entirety of which is incorporated herein by reference. However, the joint in U.S. Pat. No. 9,494,235 includes a bottom configuration which is a variant of the bottom of joint 15 which includes a more rounded or smoother bottom surface which allows a joint 15 which may compress differently than the joint shown in the 235 patent. Additional examples of expansion joints are shown in U.S. Pat. Nos. D 739,564 and D 781,466, the entirety of which, are incorporated herein by reference.

[0025] Referring now to FIG. 2, the assembly 10 in FIG. 2 is similar to the assembly 10 in FIG. 1 with the exception that the left and right sides of the assembly 10 shown in FIG. 2 include 3 extension members 56 engaged to each other and the respective base support 20. In a preferred embodiment, the distance between surfaces 30 and 28 is about 1 inch, and the distance between surfaces 28 and 68, 70 is about 1 inch. Accordingly, in the assembly configuration of FIG. 1, assembly 10 is about 2 inches high which defines the top coat 18 thickness when combined with the thickness of flange 74 and angle member 78. For the assembly configuration of FIG. 2, assembly 10 has been extended with the addition of 2 extension members 56 on each side to provide a top coat thickness of 4 inches combined with the thickness of flange 74 and angle member 78. The thinnest top coat 18 is provided when assembly 10 does not include an extension member 56. This use of common engagement formations 50 and interfaces 58 provide for a readily expandable/stackable assembly 10 which provides a form and thickness control for top coat 18 which in many cases is a concrete surface formed upon the respective floor sections 14, 16 form the final surface of a building floor or roof surface.

[0026] FIG. 3 illustrates an alternative embodiment of assembly 10. In particular, this embodiment includes a modified angle member 80 and a top plate 82 which provides a ridged cover for rubber joint 15. Such an alternative may be required where the width of expansion gap 12 may be too wide to permit joint 15 to properly support loads on top of gap 12. In this embodiment member 80 replaces angle member 78 to capture and hold flanges 74 in place as discussed above. Screws 49 are also used to hold members 80 in place. Member 80 provides a location at which top plate 82 can be fastened to one side of assembly 12. For example, members 80 include threaded holes 84 which are engaged by screws 86 to fix plate 82 to either an extension member 56 or base support 20 on one side of assembly 12 (see right side of FIG. 3). Plate 82 is not fixed to the other side of assembly 12. Rather, plate 82 only rests upon the top surface of angle member 80 on the other side of assembly 12 (see left side of FIG. 3). This permits plate 82 to slide

relative to assembly **10** on the un-fastened side when the width of gap **12** changes due to building movement/expansion/contraction.

[0027] Referring to FIG. **4**, base support **20** is shown in detail and labeled in accordance with FIGS. **1-3**.

[0028] Referring to FIGS. **6** and **7**, extension member **56** is shown in detail and partially labeled in accordance with FIGS. **1-3**. In particular, to avoid confusion, only the general features of member **56** are labeled in FIGS. **1-3** with the above-described details being labeled in FIGS. **6** and **7**.

[0029] Referring to FIGS. **8** and **9**, joint **15** is shown in detail and labeled in accordance with FIGS. **1-3**.

[0030] Referring to FIGS. **10** and **11**, angle member **80** is shown in detail and labeled in accordance with FIGS. **1-3**.

[0031] Referring to the Figures, and in particular FIGS. **1-3**, the method for installing the assembly **10** and thereby bridging the gap **12** in a building floor **14**, **16** or roof will be described in further detail. Elongated base supports **20** are first fastened to opposing floor sections **14** and **16** using concrete screws engaged with appropriately sized holes drilled into sections **14** and **16**. Based upon the required thickness of top coat **18**, the appropriate number of extension members **56** are stacked and engaged with the respective base supports **20**. By way of example, the top coat **18** thicknesses selected for the embodiments shown in FIGS. **1** and **3** required a single extension member **56** engaged and stacked on each support **20**, whereas for the embodiment shown in FIG. **2**, **3** engagement members **56** were required for each side of assembly **10**.

[0032] Subsequently, the joint **15** is positioned between each side of assembly **10** such that tabs **76** engage the respective teeth **46**, **48**. As discussed in more detail above either angle member **78** or modified angle member **80** is then screwed in place to capture the flanges **74** of joint **15**. After installation of members **78** or **80** the top coat **18** (e.g. concrete, asphalt, etc.) is installed upon floor sections **14** and **16** generally flush with the top surface of the members **78** or **80**.

[0033] If the top plate **82** embodiment is chosen, top plate **82** is positioned on the top of members **80** and the top coat **18** and fixed to one side of assembly **10**.

[0034] In various exemplary embodiments, the relative dimensions, including angles, lengths and radii, as shown in the Figures are to scale. Actual measurements of the Figures will disclose relative dimensions and angles of the various exemplary embodiments. Various exemplary embodiments include any combination of one or more relative dimensions or angles that may be determined from the Figures. Further, actual dimensions not expressly set out in this description can be determined by using the ratios of dimensions measured in the Figures in combination with the express dimensions set out in this description.

[0035] The use of the terms “a” and “an” and “the” and similar referents in the context of describing the invention (especially in the context of the following claims) is to be construed to cover both the singular and the plural, unless otherwise indicated herein or clearly contradicted by context. The terms “comprising,” “having,” “including,” and “containing” are to be construed as open-ended terms (i.e., meaning “including, but not limited to,”) unless otherwise noted. Recitation of ranges of values herein are merely intended to serve as a shorthand method of referring individually to each separate value falling within the range, unless otherwise indicated herein, and each separate value is

incorporated into the specification as if it were individually recited herein. All methods described herein can be performed in any suitable order unless otherwise indicated herein or otherwise clearly contradicted by context. The use of any and all examples, or exemplary language (e.g., “such as”) provided herein, is intended merely to better illuminate the invention and does not pose a limitation on the scope of the invention unless otherwise claimed. No language in the specification should be construed as indicating any non-claimed element as essential to the practice of the invention.

[0036] Further modifications and alternative embodiments of various aspects of the invention will be apparent to those skilled in the art in view of this description. Accordingly, this description is to be construed as illustrative only. The construction and arrangements, shown in the various exemplary embodiments, are illustrative only. Although only a few embodiments have been described in detail in this disclosure, many modifications are possible (e.g., variations in sizes, dimensions, structures, shapes and proportions of the various elements, values of parameters, mounting arrangements, use of materials, colors, orientations, etc.) without materially departing from the novel teachings and advantages of the subject matter described herein. Some elements shown as integrally formed may be constructed of multiple parts or elements, the position of elements may be reversed or otherwise varied, and the nature or number of discrete elements or positions may be altered or varied. The order or sequence of any process, logical algorithm, or method steps may be varied or re-sequenced according to alternative embodiments. By way of specific example, depending upon the application, joint **15** may be extruded from a thermoset or thermoplastic elastic compound such as an appropriate rubber material. Additionally, the preferred embodiments of base supports **20**, extension members **56** and members **78** are extruded aluminum with cross-sections as shown and described herein, there may be design considerations which result in variations in the cross-sectional shapes, and the material used for these components. For example, an appropriate plastic may be used to replace the aluminum in some or all of components **20**, **56** and **78**. Other substitutions, modifications, changes and omissions may also be made in the design, operating conditions and arrangement of the various exemplary embodiments without departing from the scope of the present invention. For example, another example of the mounting elements are a combination of magnets and/or ferromagnetic materials.

1. An adjustable height expansion joint assembly for bridging an expansion gap in a floor or roof, the assembly is attachable to surfaces of the floor or roof adjacent to the gap, the assembly comprising:

a pair of elongated base supports each including a flange which provides an attachment to a respective said surface, and a first interface having a first attachment configuration, each flange including a lower surface which rests against and is parallel to a respective said surface, the first interface being displaced from and generally parallel to the lower surface;

at least a pair of elongated extension members each having a first side including a second interface which includes a second attachment configuration which mates with the first interface to join the elongated extension member to the respective elongated base support, each elongated extension member further including a second side opposite to and generally

- parallel with the first side, the second side including a third interface having a third attachment configuration, the third attachment configuration being the same as the first attachment configuration; and
- an elongated expansion joint including a pair of flanges attachable to a respective said third interfaces to bridge a gap between the surfaces;
- wherein the first attachment configuration includes at least three elongated walls; and
- wherein two opposing walls of the at least three elongated walls include a plurality of opposed notches which cooperate to provide a location into which a threaded screw can be engaged.
2. The expansion joint assembly of claim 1, further comprising:
- a pair of elongated cover members which attach to a respective said third interface to capture a respective flange of said pair of flanges between the respective third interface and the respective elongated cover member.
3. The expansion joint assembly of claim 2, wherein the expansion joint is fabricated from an elastic material.
4. The expansion joint assembly of claim 1, wherein the three elongated walls define a pair of parallel channels extending the length of a respective base support or extension member, each channel including at least one engagement flange.
5. The expansion joint assembly of claim 4, wherein the second attachment configuration includes at least 2 engagement members extendable into a respective said channel and including an engagement member engageable with a respective engagement flange to join and hold the elongated extension member in engagement with a respective said elongated base support.
6. The expansion joint assembly of claim 5, wherein each flange of the expansion joint includes an engagement extension and wherein the plurality of opposed notches are configured for gripping a respective said engagement extension.
7. The expansion joint assembly of claim 1, further comprising a second pair of elongated extension members joinable between respective said elongated base supports and said elongated extension member.
8. An assembly for forming the edge of a top coating applied to a floor or roof and the assembly being attachable to a surface at the edge of the floor or roof adjacent to an expansion gap, the assembly being configured to support one side of an elongated expansion joint which bridges the expansion gap, the assembly comprising:
- an elongated base support including a flange which provides an attachment to a respective said surface, and a first interface having a first attachment configuration, the flange including a lower surface which rests against and is parallel to a respective said surface, the first interface being displaced from and generally parallel to the lower surface at a first distance; and
- a first elongated extension member having a first side including a second interface which includes a second attachment configuration mated with the first interface to join the elongated extension member to the respective elongated base support, the first elongated extension member further including a second side displaced at a second distance from, opposite to and generally parallel with the first side, the second side including a

- third interface having the first a third attachment configuration, the third attachment configuration being the same as the first attachment configuration, the top coating having a thickness defined by at least the sum of the first and second distances, wherein one side of the expansion joint is attached to the third interface;
- wherein the first attachment configuration includes at least three elongated walls; and
- wherein two opposing walls of the at least three elongated walls include a plurality of opposed notches which cooperate to provide a location into which a threaded screw can be engaged.
9. The assembly of claim 8 further comprising a second elongated extension member having the same configuration as the first elongated extension member, wherein the second interface of the second elongated extension member is joined to the third interface of the first elongated extension member with the thickness of the top coating being further defined by the second distance of the second elongated extension member, wherein the one side of the expansion joint is attached to the third interface of the second elongated extension member instead of the third interface of the first elongated extension member.
10. The assembly of claim 9 further comprising a third elongated extension member having the same configuration as the first elongated extension member, wherein the second interface of the third elongated extension member is joined to the third interface of the second elongated extension member with the thickness of the top coating being further defined by the second distance of the third elongated extension member, wherein the one side of the expansion joint is attached to the third interface of the third elongated extension member instead of the third interface of the second elongated extension member.
11. The expansion joint assembly of claim 8, wherein three elongated walls define a pair of parallel channels extending the length of a respective said base support or said extension member, each channel including at least one engagement flange.
12. The expansion joint assembly of claim 11, wherein the second attachment configuration includes at least 2 engagement members extendable into a respective said channel and including an engagement member engageable with a respective engagement flange to join and hold the elongated extension member in engagement with a respective said elongated base support.
13. The expansion joint assembly of claim 12, wherein each flange of the expansion joint includes an engagement extension and at least one of the pair of parallel channels includes a plurality of opposed notches for gripping a respective said engagement extension.
14. The expansion joint assembly of claim 10, wherein the first attachment configuration includes at least 3 elongated walls which define a pair of parallel channels extending the length of a respective said base support or said extension member, each channel including at least one engagement flange.
15. The expansion joint assembly of claim 14, wherein the second attachment configuration includes at least 2 engagement members extendable into a respective said channel and including an engagement member engageable with a respective engagement flange to join and hold the elongated extension member in engagement with a respective said elongated base support.

16. The expansion joint assembly of claim **15**, wherein each flange of the expansion joint includes an engagement extension and wherein the plurality of opposed notches are configured for gripping a respective said engagement extension.

17. A method for bridging an expansion gap in a floor or roof and forming the edge for a top coating applied to the surface of a respective floor or roof, the method comprising:

attaching a flange of an elongated base support to the surface, the base support having a first interface having a first attachment configuration, the first interface being displaced from and generally parallel to the lower surface at a first distance;

attaching at least a first elongated extension members to the elongated base, the elongated extension member having a first side including a second interface which includes a second attachment configuration engaged with the first interface, the elongated extension member further including a second side displaced at a second distance from, opposite to and generally parallel with the first side, the second side including a third interface having the first attachment configuration; and

attaching one side of the expansion joint to the third interface, the top coating having a thickness defined by at least the sum of the first and second distances;

wherein the step of attaching one side of the expansion joint to the third interface comprises:

inserting an engagement extension of a flange of the expansion joint into a channel defined by two elongated walls of the third interface;

positioning an angle member over the flange so that the flange is between the third interface and the angle member; and

inserting a fastener through the angle member and the flange into the same channel as the engagement extension, the fastener engaging a plurality of opposed notches formed into the two elongated walls.

18. The method of claim **17**, further comprising the step of:

attaching a second elongated extension member having the same configuration as the first elongated extension member to the first elongated extension member instead of the expansion joint, wherein the second interface of the second elongated extension member is joined to the third interface of the first elongated extension member; and

attaching one side of the expansion joint to the third interface of the second elongated extension member, the top coating having a thickness defined by at least the sum of the first and second distances.

19. The method of claim **18**, further comprising the step of:

attaching a third elongated extension member having the same configuration as the first elongated extension member to the second elongated extension member instead of the expansion joint, wherein the second interface of the third elongated extension member is joined to the third interface of the second elongated extension member; and

attaching one side of the expansion joint to the third interface of the third elongated extension member, the top coating having a thickness defined by at least the sum of the first and second distances.

20. The method of claim **19** wherein the first and second distances are equal.

21. The expansion joint assembly of claim **1**, wherein the first configuration comprises only three elongated walls, wherein tops of two adjacent elongated walls are offset from and parallel to a top of a third elongated wall.

22. The expansion joint assembly of claim **21**, wherein the plurality of opposed notches on the two opposing walls are located on the two adjacent walls.

23. The expansion joint assembly of claim **1**, further comprising a top plate configured to provide a rigid cover for the expansion joint.

* * * * *