

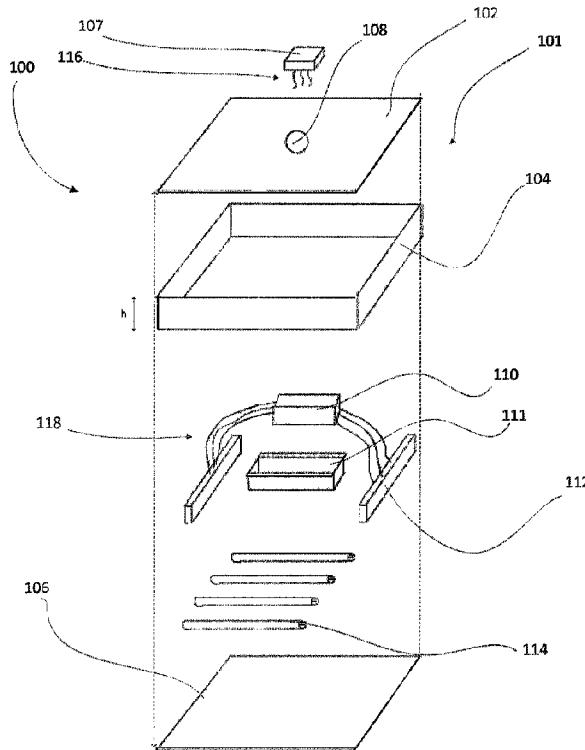

(86) Date de dépôt PCT/PCT Filing Date: 2015/11/11
 (87) Date publication PCT/PCT Publication Date: 2016/05/19
 (45) Date de délivrance/Issue Date: 2023/10/17
 (85) Entrée phase nationale/National Entry: 2017/05/11
 (86) N° demande PCT/PCT Application No.: IB 2015/058719
 (87) N° publication PCT/PCT Publication No.: 2016/075640
 (30) Priorité/Priority: 2014/11/11 (US62/078,161)

(51) Cl.Int./Int.Cl. *H05B 45/357* (2020.01),
F21K 9/00 (2016.01), *F21V 23/06* (2006.01),
H01R 33/22 (2006.01), *H02G 3/08* (2006.01)
 (72) Inventeurs/Inventors:
 TEMPORAO, JOSE, CA;
 BYRON, DAVID, CA
 (73) Propriétaire/Owner:
 INTELLIGENT LIGHTING TECHNOLOGIES INC., CA
 (74) Agent: NORTON ROSE FULBRIGHT CANADA
 LLP/S.E.N.C.R.L., S.R.L.

(54) Titre : ADAPTATEURS D'AMPOULE A DEL ET PROCEDES DE RATTRAPAGE D'AMPOULES A DEL
 (54) Title: LED BULB ADAPTERS AND METHODS OF RETROFITTING LED BULBS



(57) **Abrégé/Abstract:**

A method of retrofitting a fluorescent tube light fixture with an LED bulb adapter is provided. The method comprises removing a lens, a ballast, and a fluorescent tube receptacle from a reflector housing to expose a mains power supply line entry point. A LED bulb adapter comprises a body defining an electrical enclosure, the body having a mounting flange defining a central opening to receive the mains power supply line, the body having a plurality of bulb arms each mounting an Edison socket light-emitting diode (LED) bulb socket. The mains power supply line is then wired to the plurality of Edison socket light-emitting diode (LED) bulb sockets extending from the body of the LED bulb adapter. The mounting flange is then secured on a surface of the reflector housing, a plurality of LED bulbs is threaded into the bulb sockets, and the lens is installed into the housing.

Abstract

A method of retrofitting a fluorescent tube light fixture with an LED bulb adapter is provided. The method comprises removing a lens, a ballast, and a fluorescent tube receptacle from a reflector housing to expose a mains power supply line entry point. A LED bulb adapter comprises a body defining an electrical enclosure, the body having a mounting flange defining a central opening to receive the mains power supply line, the body having a plurality of bulb arms each mounting an Edison socket light-emitting diode (LED) bulb socket. The mains power supply line is then wired to the plurality of Edison socket light-emitting diode (LED) bulb sockets extending from the body of the LED bulb adapter. The mounting flange is then secured on a surface of the reflector housing, a plurality of LED bulbs is threaded into the bulb sockets, and the lens is installed into the housing.

LED BULB ADAPTERS AND METHODS OF RETROFITTING LED BULBS

CROSS-REFERENCE TO RELATED APPLICATIONS

5 [0001] This claims priority from United States provisional application no. 62/078,161, filed on November 11, 2014.

FIELD

[0002] The improvements generally relate to the field of lighting fixtures, and in particular, to LED lighting fixtures.

BACKGROUND

10 [0003] Fluorescent light fixtures are ubiquitous in many applications, such as industrial, commercial and residential buildings, vessels, and the like. Some building technologies are designed around fluorescent light fixtures. For example, some types of suspended ceilings are designed to accommodate fluorescent fixtures of certain standard sizes.

15 [0004] Typical fluorescent light fixtures include a housing and a ballast circuit, adapted to receive standard mains power such as North American standard 120V/60Hz AC power, 347V AC power or 277V AC power, as input, and produce suitable output power for driving fluorescent tubes.

20 [0005] Advances in the lighting industry have led to wide availability of many types of lightbulbs, including traditional incandescent and fluorescent bulbs, as well as light-emitting diode (LED) bulbs.

[0006] LEDs typically provide certain advantages over traditional fluorescent lights. For example, LED lights are typically much more energy efficient and have a longer service life relative to fluorescent and incandescent lights.

25 [0007] Such lights require appropriate fixtures in which to be installed. Unfortunately, some common existing fixture types, such as fluorescent tube fixtures, are not suitable for most LED lights. For example, power delivered fluorescent tube fixtures may not be compatible with most LED lights, and such lights may not produce desirable light distribution

with existing fixtures. Accordingly, retrofitting may be required to take advantage of existing installations.

SUMMARY

[0008] Disclosed herein is a method of retrofitting a plurality of LED bulbs configured for
5 removable connection to an Edison socket bulb receptacle, to a fluorescent tube fixture
having a ballast, a fluorescent tube receptacle for receiving pins of a fluorescent tube, and
an enclosure defined by a reflector housing and a lens. The method comprises: removing
the lens from the reflector housing; disconnecting the ballast from a mains power supply line
and removing the ballast and the fluorescent tube receptacle from the housing; wiring the
10 mains power supply line to a plurality of Edison socket light-emitting diode (LED) bulb
sockets extending from a body defining an electrical junction box, the bulb sockets
configured to distribute light from the LED bulbs across the lens and the reflector; threading
a plurality of LED bulbs into the bulb sockets; mounting the electrical junction box to the
reflector housing; installing the lens to the housing such that the bulb adapter is received in
15 an enclosure defined by the housing and the lens.

[0009] Also disclosed herein is a bulb adapter for retrofitting light-emitting diode (LED)
bulbs to a fluorescent tube fixture having a ballast and an enclosure defined by a reflective
housing and a lens, the bulb adapter comprising: a body defining an electrical junction box; a
plurality of LED bulb sockets extending in different directions from the body to hold LED
20 bulbs in a generally planar arrangement inside the enclosure; a mounting flange defining an
opening in the body for receiving a mains power supply line to connect the mains power
supply line to the LED bulb sockets, the mounting flange for securing the body to the
housing so that the LED bulbs distribute light across the reflective housing and the lens.

[0010] Many further features and combinations thereof concerning embodiments
25 described herein will appear to those skilled in the art following a reading of the instant
disclosure.

DESCRIPTION OF THE FIGURES

[0011] In the figures which illustrate example embodiments,

- [0012] **FIG. 1** is an exploded view of a fluorescent light fixture with tubes;
- [0013] **FIG. 2** is a perspective view of a LED bulb adapter with bulbs;
- [0014] **FIG. 3** is a bottom view of the LED bulb adapter of **FIG. 2**;
- [0015] **FIG. 4** is a cross-sectional view of the LED bulb adapter of **FIG. 3** along line **IV-IV**
5 shown in **FIG. 3**;
- [0016] **FIG. 5** is an exploded view of a light fixture including the LED bulb adapter and bulbs of **FIG. 2**;
- [0017] **FIG. 6** is a perspective view of another LED bulb adapter;
- [0018] **FIG. 7** is a bottom view of the LED bulb adapter of **FIG. 6**;
- 10 [0019] **FIG. 8** is a cross-sectional view of the LED bulb adapter of **FIG. 6** along line **VIII-VIII** shown in **FIG. 7**;
- [0020] **FIG. 9** is a cross-sectional view of the LED bulb adapter of **FIG. 6** along line **IX-IX** shown in **FIG. 7**;
- [0021] **FIG. 10** is an exploded view of another fluorescent light fixture with tubes;
- 15 [0022] **Fig. 11** is an exploded view of a light fixture including the LED bulb adapter of **Fig. 6** with bulbs;
- [0023] **FIG. 12** is a flow chart depicting a method of retrofitting;
- [0024] **FIG. 13** is a bottom view of an LED bulb adapter with diffusers;
- [0025] **FIGS. 14A-14B** are perspective and front views of a diffuser of **FIG. 13**;
- 20 [0026] **FIG 15** is a bottom view of another LED bulb adapter with bulbs;
- [0027] **FIG. 16** is a bottom view of a fixture with the LED bulb adapter of **FIG. 6** and bulbs;

[0028] **FIG. 17** is a perspective view of an example high-pressure sodium wall pack fixture;

[0029] **FIG. 18** is a perspective view of a bulb adapter for installation to the wall pack fixture of **FIG. 17**;

5 [0030] **FIG. 19** is a schematic view of an example high pressure sodium lamp circuit; and

[0031] **FIG. 20** is a schematic view of a bulb arm of an LED bulb adapter.

DETAILED DESCRIPTION

[0032] **FIG. 1** is an exploded view of an example fluorescent light fixture **100** which may, for example, be installed in a commercial or residential building.

10 [0033] Fluorescent light fixture **100** includes an enclosure defined by a housing **101** and a lens **106**. Housing **101** includes a top plate **102** and a plurality of walls **104**. Each of top plate **102** and walls **104** has a reflective internal surface. Lens **106** is mounted to housing **101** opposite top plate **102**. Lens **106** may, for example, be hinged or clipped to walls **104**. Lens **106** may be transparent or translucent to scatter light. Housing **101** may be mounted
15 to a ceiling such as a suspended ceiling (not shown). For example, housing **101** may be received in a recess in a ceiling. Top plate **102** has a hole **108** to receive wiring for driving light fixture **100**. Hole **108** may be aligned with a junction box **107**.

[0034] Fluorescent light fixture **100** may be sized to receive fluorescent tubes of a standard length, and in turn, to be received in a lighting recess of a standard size in a wall or
20 ceiling. For example, fluorescent light fixture **100** may be sized to receive tubes 2, 3, 4 or 8 feet in length, and to be received in a 2 foot by 2 foot, 2 foot by 4 foot, 1 foot by 4 foot, 1 foot by 8 foot, 2 foot by 8 foot or 2 foot by 4 foot recess. Fluorescent fixture 100 may also be surface mounted rather than mounted in a recess. Fluorescent tubes may be cylindrical, as depicted. Alternatively, fluorescent tubes may be U-shaped or circular.

25 [0035] Housing **101** of fluorescent light fixture **100** may have a height **h** defined by walls **104**. Height **h** may be sufficient to so that internal components of light fixture **100** may be

fully enclosed between housing **101** and lens **106**. In an example, height h may be 3.5 inches. In other embodiments, height h may be more or less than 3.5 inches.

[0036] Fluorescent light fixture **100** has a ballast **110** and a plurality of fluorescent tube holders **112**. Fluorescent tubes **114** may be installed in light fixture **100** by mounting in tube holders **112**. Though light fixture **100** has a single ballast **110**, other fixtures may have multiple ballasts, as will be apparent to skilled persons.

[0037] Fluorescent tubes **114** may for example be standard mercury-vapor lamps with single-pin or bi-pin connectors, such as T12, T8 or T5 lamps. In some embodiments, **114** may be rated for wattage of approximately 30-55 watts each. As depicted, four fluorescent tubes **114** are installed in fixture **100**. However, in other embodiments, more or fewer tubes may be present.

[0038] Tubes **114** are elongate, and may for example be approximately 4 feet long and 1-2 inches in diameter. Accordingly, as will be apparent, tubes **114** distribute light throughout housing **101** and lens **106**. The elongate shape of tubes **114**, combined with the reflectivity of the inner surfaces of housing **101** and translucency of lens **106** scatters light emanating from fixture **100** so that a desirable lighting pattern is achieved.

[0039] Ballast **110** is wired to mains power, e.g. North American 120V/60Hz AC household power, or 347V AC power through mains power supply lines **116**. Ballast **110** is wired to tubes **114** through tube holders **112** and ballast output lines **118**. Ballast **110** is enclosed within a ballast cover **111** for safety reasons.

[0040] As is well known to skilled persons, ballast **110** converts and conditions ballast input power to safely drive tubes **114**. For example, ballast **110** provides a start-up voltage to turn on tubes **114** and limits voltage and current through tubes **114** during operation. Tubes **114** typically have contact pins, which creates a relatively high risk of inadvertent short circuit during installation or removal of tubes **114**. The fluctuating voltage delivered by ballast **110** increases the danger associated with such short-circuits and overheating. Safety regulations typically require that lines carrying mains power (e.g. 120V or 347V) be enclosed within ballast cover **111**.

[0041] Ballast **110** typically consumes power during operation. In an example, a ballast **110** for driving T8 fluorescent tubes may consume on the order of 10 W and a ballast **110** for driving T12 fluorescent tubes may consume on the order of 20 W.

[0042] LED lamps may be more efficient than typical fluorescent lamps. For example,
5 some LED lamps may consume on the order of 70% less power than fluorescent lamps to produce a corresponding amount of light.

[0043] It may therefore be desired to use LED tube lamps with fluorescent light fixture **100**. However, electrical characteristics of typical LED tubes differ from those of typical fluorescent tubes. For example, LEDs typically require DC power and different voltage than
10 that required by fluorescent tubes. Thus, use of LED tubes with fixture **100** would require a specific LED driver instead of or in addition to ballast **110**. Such drivers are costly and tend to frequently need replacement.

[0044] **FIG. 2** depicts a perspective view of a lighting assembly **200** configured for retrofitting to fixture **100**. Lighting assembly **200** includes a LED bulb adapter **201** and a
15 plurality of high-efficiency bulbs, such as LED bulbs **220**. Lighting assembly **200** allows for the elimination of ballast **110** or a separate LED driver and permits safe installation, operation and removal of bulbs. Typically, LED bulbs **220** are rated for 25 W or less. LED bulbs **220** may produce more light per unit wattage than incandescent or fluorescent lamps. Using relatively low-wattage LED bulbs (e.g. <25W) may limit risk of overheating issues.
20 Suitable bulbs are available from numerous manufacturers, such as Philips, GE, Sylvania and Cree.

[0045] LED bulb adapter **201** has an electrical enclosure **202** and a plurality of bulb arms **204** which extend away from electrical enclosure **202**. As depicted, electrical enclosure **202** is an electrical junction box, which may be configured and approved to safely house
25 connections between wires carrying mains (e.g. household 120V AC) power. Electrical enclosure **202** is generally rectangular, with four lateral side walls and a top side having a mounting flange **206** defining a central opening **208**. However, other shapes are possible.

[0046] Bulb arms **204** extend in different directions away from electrical enclosure **202**. As depicted in **FIGS. 2-4**, LED bulb adapter has four bulb arms **204**, one extending from each lateral side of the electrical enclosure **202**. Bulb arms **204** may be integrally formed with electrical enclosure **202**, or may be attached thereto.

5 [0047] In an example, electrical enclosure **202** and bulb arms **204** may be formed from a non-flammable and electrically non-conductive material, such as polyvinyl chloride according to Ontario Provincial Standard Specification OPSS 2492. Other suitable materials will be apparent to skilled persons.

[0048] In some embodiments, LED bulb adapter **201** may be safety certified for use as an
10 electrical junction box. For example, LED bulb adapter **201** may carry a certification by UL LLC.

[0049] Bulb arms **204** include metallic bulb sockets **222**. Bulb sockets **222** have internal threads **224** for receiving and releasably retaining bulbs **220**. Bulb sockets **222** electrically engage bulbs **220**. Bulb sockets **222** may be standard Edison sockets, such as ANSI or IEC
15 specified standard screw-type sockets. Such sockets are commonly used for incandescent bulbs. In an example, bulb sockets **222** may be configured to receive bulbs having a standard E26 medium base. Alternatively, bulb sockets **222** may be configured to receive bulbs with other standard or non-standard bases. Edison-socket LED bulbs are widely available in many sizes, shapes, wattage ratings, colours, and other variations. Such LED
20 bulbs typically include integrated drivers within the bulb housings for converting mains (e.g. 120V AC) power to DC power for driving LEDs.

[0050] Bulb sockets **222** may be secured to electrical enclosure **202** by fasteners **216**. Fasteners **216** may be screws or any other suitable fasteners. Fasteners **216** may be received in and engage sockets **227** defined in bulb sockets **222** (see **FIG. 4**). Bulb sockets
25 **222** may also have a plurality of terminals **226** for receiving electrical power. As depicted, bulb sockets **222** have terminals **226** for connection to positive and negative leads.

[0051] Electrical enclosure **202** has a plurality of holes **212** through which wires **209** may be passed for connection to terminals **226**. Electrical enclosure **202** may be positioned with

central opening **208** abutting an electrical connector such as a junction box, and leads from the electrical junction box may be received through central opening **208** and joined to leads connected with terminals **226** through openings **212**. Thus, electrical enclosure **202** may be mounted within a fixture, defining an electrical box within the fixture abutting and extending
5 another electrical box outside the fixture. This is contrary to typical light fixture arrangements, in which the mains connections are enclosed outside the fixture.

[0052] Electrical enclosure **202** is also equipped with a plurality of knock-out panels **210**. Knock-out panels **210** are defined by regions of decreased wall thickness and can be removed from electrical enclosure **202** by manual application of pressure to create windows
10 allowing wires to be passed through.

[0053] For example, wiring of some fluorescent fixtures may require mains power supply lines **116** to be routed other than through a central hole **108** in top panel **102**. In such embodiments, power supply wires may be routed to a knock-out rather than through top opening **208**. A standard electrical connector may be mounted at the knock out to allow for
15 a safe connection, e.g. ½ inch metal or plastic connectors, as are commonly available.

[0054] In an example, an extension ring may be fitted over a junction box, and a cable (e.g. a mechanically protected or armored cable) may be run from the junction box to an electrical connector in a knock-out. Such an arrangement may be referred to as a “whip” and may permit LED bulb adapter **201** to be placed at any location relative to the junction
20 box.

[0055] A plurality of sleeves **214** are defined on the interior of body **214**. Sleeves **214** can receive fasteners, e.g. screws, to secure a bottom panel **225** to electrical enclosure **202**. For the sake of illustration, bottom panel **225** is omitted from **FIGS. 3** and **5**.

[0056] A plurality of mounting holes **207** may be formed in flange **206**. Mounting holes
25 may receive screws or other suitable fasteners for attaching electrical enclosure **202** to a fixture housing, wall or ceiling. In some embodiments, electrical enclosure **202** may be attached using self-tapping screws. Use of such screws may avoid the need to align mounting holes **207** with pilot holes in fixture **100**. Mounting holes **207** may be reinforced by

tabs **218**, formed as regions of flange **206** with increased thickness. When mounted, mounting flange **206** may tightly abut the surface to which LED bulb adapter **201** is attached, namely, top panel **102** of fixture **100**, a wall, a ceiling or the like.

[0057] LED bulb adapter **201** may be used to retrofit fixture **100** to use LED bulbs. **FIG. 5** depicts an exploded view of a fixture **300**, similar to fixture **100** except that ballast **110**, ballast holder **111**, tube holder **112** and fluorescent tubes **114** have been replaced with LED bulb adapter **201** and LED bulbs **220**. Like components of fixtures **100**, **300** are identified with like numerals.

[0058] Mains power supply lines **116** are routed through opening **208** of electrical enclosure **202** and connected with bulb sockets **222** through holes **212**. Conveniently, LED bulb adapter **201** encloses mains power supply lines **116** to protect against shock hazards due to the voltage of mains power supply lines **116**.

[0059] As will be apparent from **FIG. 5**, LED bulb adapter **201** holds LED bulbs **220** so that light emitted by LED bulbs **220** is distributed across housing **101** and lens **106** of fixture **300**. That is, bulb arms **204** extend in different directions such that one LED bulb **220** is held proximate each corner of housing **101**. Thus, light is distributed across the inner surface of housing **101** and reflected toward lens **106**, which further scatters light exiting the fixture. Accordingly, LED bulb adapter **201** may cooperate with housing **101** and lens **106** to achieve light distribution similar to that provided by fluorescent tubes **114**.

[0060] Moreover, while LED bulb adapter holds LED bulbs **220** to cooperate with housing **101** and lens **106** for effective light distribution, the substantially planar configuration of bulb arms **204** limits the height of LED bulb adapter **201** and the associated bulbs **220**, such that they fit entirely within the enclosure defined by housing **101** and lens **106**.

[0061] Bulb arms **204** may be offset from mounting flange **206** to provide spacing of bulbs **220** from the surface to which LED bulb adapter **201** is mounted. Such spacing may be selected to ensure clearance of certain types of LED bulbs **220**, to ensure that such bulbs fit within the enclosure defined by housing **101** and lens **106** of fixture **100**, and to provide a

desired light distribution. In an example, an offset **O** between the top of mounting flange **206** and the midline of bulb arms **204** may be approximately 1 3/16 inches.

[0062] In an example, each side of electrical enclosure **202** may be approximately 4 inches long and electrical enclosure **202** may be approximately 2 4/16 inch thick. Bulb sockets **204** may extend approximately 1 3/4 inch from electrical enclosure **202** and top opening **208** may be approximately 3 inches by 3 inches. The inventors have determined that such dimensions ensure acceptable distribution of light and provide for flexibility of installation.

[0063] LED bulb adapter **201** depicted in **FIGS. 2-4** has four bulb arms **204** for receiving four LED bulbs. Other configurations are also possible.

[0064] For example, **FIGS. 6-7** depict perspective and bottom views, respectively, of a LED bulb adapter **401** having two bulb arms **204** to receive two LED bulbs.

[0065] Bulb arms **204** of LED bulb adapter **401** are identical to bulb arms **204** of LED bulb adapter **201**.

[0066] LED bulb adapter **401** has an electrical enclosure **402**, generally similar to electrical enclosure **202** of LED bulb adapter **201**, but with a narrower rectangular shape. Bulb arms **204** of LED bulb adapter **401** extend from opposing ends of electrical enclosure **402** to hold bulbs in a generally planar arrangement.

[0067] LED bulb adapter **401** is configured for installation to a fluorescent fixture designed to hold two bulbs. In an example, electrical enclosure **402** of LED bulb adapter **401** is suited for installation to a fixture 1 foot by 4 feet, 1 foot by 8 feet, 2 feet by 2 feet, 2 feet by 4 feet or 2 feet by 8 feet.

[0068] Electrical enclosure **402** has a mounting flange **406** defining a top opening **408** for receiving mains power supply lines **116** (**FIG. 1**). Flange **406** has a plurality of mounting holes **407** for receiving fasteners such as screws for fixing electrical enclosure **402** to a fixture, ceiling or wall. Mounting holes are reinforced by tabs **418** formed on flange **406**, having increased wall thickness.

[0069] Opening **408** is sufficiently large to provide significant clearance for passing mains power supply lines **116** into electrical enclosure **402**. Such clearance may provide ease and flexibility of installation, as electrical enclosure **402** need not be precisely aligned.

[0070] Electrical enclosure **402** has holes **412** for routing of wires **409** to terminals **224** of bulb arms **204**. In addition, electrical enclosure **402** has a plurality of knock-out panels **410** defined by regions of decreased wall thickness, substantially similar to knock-out panels **210**.

[0071] In an example, LED bulb adapter **401** may have an offset **O** between mounting flange **406** and the midline of bulb arms **204** of approximately 1 3/16 inches. Electrical enclosure **402** may be approximately 2 1/4 inches wide and 4 inches long and approximately 2 4/16 inches thick (thickness refers to the dimension from mounting flange 206 to bottom panel 225). Top opening **408** may be approximately 3 inches long by 1 1/2 inches wide.

[0072] As noted, LED bulb adapter **401** has a narrower body than that of LED bulb adapter **201** and its bulb arms **204** extend away from each end of electrical enclosure **402**. Thus, LED bulb adapter **401** is well suited for long and narrow fixtures, such as those designed for holding a pair of T12 or T8 fluorescent tubes. **FIG. 10** shows an exploded view of an example fixture **100'**, identical to fixture **100** except that it is sized to hold two, rather than four fluorescent tubes **114**.

[0073] **FIG. 11** shows an exploded view of a fixture **300**, identical to fixture **100'**, except that LED bulb adapter **401** and bulbs **220** are retrofitted in place of ballast **110**, ballast cover **111**, tube holders **112** and fluorescent tubes **114**. LED bulb adapter **401** holds LED bulbs **220** so that light emitted by LED bulbs **220** is distributed across the fixture housing and lens. That is, LED bulb adapter **401** holds an LED bulb proximate each end of such a fixture. Thus, light is distributed across the fixture housing and reflected toward lens 106, which further scatters light exiting the fixture.

[0074] Moreover, the height and generally planar arrangement of LED bulb adapter **401** permits the bulb adapter and associated bulbs **220** to be fully enclosed.

[0075] **FIG. 12** depicts a method **S600** of retrofitting an LED bulb adapter **201, 401** and LED bulbs **220** to a fluorescent light fixture **100, 100'**.

[0076] At block **S602**, lens **106** is removed from housing **101**. Typically, lens **106** is secured to housing **101** by one or more clips, in which case the clips are disengaged.
5 Alternatively, lens **106** may be slid out of housing **101** or fasteners holding lens **106** to housing **101** may be removed. In some embodiments, lens **106** may be hingedly attached to housing **101** and may hang from housing **101** after removal.

[0077] Removal of lens **106** provides access to the interior of housing **101**. Accordingly, at block **S604**, tubes **114** may be removed from tube holders **112**. As noted above, tubes
10 **114** may have a pair of contact pins that are received in tube holders **112**. Typically, each tube **114** is rotated about its longitudinal axis to release its pins from tube holders **112**. Once the pins are released, the tube **114** is lifted from tube holders **112**.

[0078] Tubes **114** are removed one at a time. Removal of tubes **114** provides access to ballast cover **111**.

15 [0079] At block **S606**, ballast cover **111** is removed. In some embodiments, ballast cover **111** is secured to top plate **102** by clips, which may be released to remove ballast cover **111**. Alternatively, ballast cover may be secured to top plate **102** by fasteners such as screws, which may be removed to remove ballast cover **111**. Prior to or following removal of ballast cover **111**, power to the fixture may be disconnected, e.g. at a circuit breaker.

20 [0080] At block **S608**, tube holders **112** are removed from top plate **102** by unfastening screws securing the tube holders to the top plate **102**. Once the tube holders are unscrewed from top plate **102**, tube holders **112** may hang from ballast output lines **118** which may still connect tube holders **112** to ballast **110**.

[0081] At block **S610**, ballast **610** is removed from top plate **102** by releasing one or more
25 clips, removing one or more fasteners, sliding ballast **110** out of a retainer, or a combination thereof. Ballast **110**, output lines **118** and tube holders **112** are then lifted out of housing **101** as an assembly.

[0082] At block **S612**, mains power supply lines **116** are threaded through top opening **208, 408** and connected to wires **209, 409** to provide power to bulb sockets **222** and thus, to bulbs **220**. Connections between mains power supply lines **116** and wires **209, 409** may be made, for example, using wire nuts. In some cases, each mains power supply line **116** may
5 be connected to a corresponding wire **209, 409** of more than one contact assembly **222**.

[0083] If required by the wiring configuration of the fixture to which LED bulb adapter **201, 401** is being retrofitted, a knock-out panel **210, 410** may be removed and a suitable electrical connector installed in the resulting opening. Mains power supply lines **116** may then be routed through the connector and knock-out to connect with wires **209, 409**.

10 [0084] At block **S614**, LED bulb adapter **201, 401** is fastened to the fixture housing by positioning top opening **218, 418** in alignment with hole **108** and inserting fasteners, e.g. screws, through mounting holes **207, 407**.

[0085] At block **S616**, LED bulbs are threaded into bulb sockets **222**.

[0086] At block **S618**, lens **106** is reinstalled to fixture housing **101**.

15 [0087] Conveniently, the above-described method may be performed without requiring skilled labor, and with a minimum of tools.

[0088] Moreover, in some instances, it may be desired to replace LED bulbs **220**. For example, bulbs **220** of different types may be swapped, or defective or inoperative bulbs may be replaced with working bulbs. As will be apparent, such replacements may be
20 inexpensive and may be performed manually without any tools, for example, by a building resident or superintendent, without need for an electrician. Conversely, replacing a ballast **110** in a fluorescent fixture such as fixture **100** may be difficult and expensive and may require specialized tools or training.

[0089] In some embodiments, one or more diffusers may be mounted to LED bulb adapter
25 **201, 401** to further scatter light produced by LED bulbs **220**. **FIG. 12** depicts a bottom view of an example LED bulb adapter **201** with a diffuser **228** mounted to each bulb socket **204** to scatter light produced by each respective LED bulb **220**.

[0090] **FIGS. 14A-14B** depict a diffuser **228** in isometric view and front views, respectively. Diffuser **228** has a baffle portion **230** and a retaining ring **232**. Retaining ring **232** is sized to fit tightly over bulb socket **204**. Retaining ring **232** is formed of a resiliently deformable material, such as UL 5VA polyvinyl chloride (PVC). Retaining ring **232** may thus
5 be deformed slightly to clip over bulb arm **204**, and once clipped over bulb arm **204**, retaining ring may tightly grip bulb arm **204** to secure diffuser **228** thereto.

[0091] Baffle portion **230** is formed in a lattice pattern, with grating **234** defining a grid of apertures **236**. Light produced by LED bulbs **220** may diffract as it passes through apertures **236**, causing scattering of the light. In an example, each aperture **236** is approximately 2
10 mm wide and 5.5 mm long and grating **234** is approximately 2 mm thick.

[0092] Baffle portion **230** may have multiple constituent surfaces, either or both of which may be inclined and which may be angled relative to one another. For example, as best shown in **FIG. 14B**, baffle portion **230** has two surfaces **230-1** and **230-2**, each of which is angled at approximately 15 degrees to horizontal, and which are angled at approximately
15 150 degrees relative to one another. Angling of surfaces **230-1**, **230-2** may improve the diffractive effect of diffuser **228**.

[0093] Grating **236** may have a reflective surface so that light hitting the grating is reflected and further scattered. For example, grating **236** may be formed of a metallic material with a shiny finish, or may be painted or otherwise covered in a white, silver or
20 mirrored coating. Thus, baffle **230** further scatters light produced by LED bulbs **220**, such that when installed in a fluorescent fixture, LED bulb adapter **201**, **401**, LED bulbs **220** and baffles **230** cooperate with the fixture housing and lens to produce a diffuse lighting pattern.

[0094] Retaining ring **232** is configured to hold baffle portion **230** at a specific distance from bulb arm **204** (and thus, LED bulb **220**) to produce the desired diffractive effect. In an
25 example, retaining ring **232** holds baffle portion **230** at a distance of approximately 10 mm below bulb arm **204**.

[0095] Moreover, to ensure that diffuser **228** scatters a sufficient portion of the light produced by LED bulb **220**, baffle portion **230** may extend a specific distance beyond the

end of bulb arm **204**. In an example, baffle portion **230** extends approximately 100 mm past bulb arm **204**.

[0096] Optionally, baffle portion **230** of diffuser **228** may be pivotally mounted to retaining ring **232** to enable selective repositioning of baffle portion **230** relative to bulb are **204** and
5 bulb **220**.

[0097] In some embodiments, baffle portion **230** or grating **236** may be formed in a specific shape, such that diffuser **228** casts a shadow and lighting pattern of corresponding shape. For example, baffle portion **230** or grating **236** may be formed in the shape of a logo, or to create a specific pattern of light and dark regions.

10 [0098] In some embodiments, LED bulb adapters may have hinged bulb arms. For example, **FIG. 15** depicts a bottom view of an LED bulb adapter **201'** similar to LED bulb adapter **201**. LED bulb adapter **201'** has four bulb arms **204'**, each of which has a proximal link **240** and a distal link **242**, connected by a hinge **244**. LED bulbs **220** are received in each distal link **242**. Each distal link **242** can be pivoted about its respective hinge **244** to
15 aim in a desired direction. Thus, LED bulbs **220**, and the light they produce may be aimed. For example, LED bulbs **220** may be aimed based on the fixtures to which they are installed to cooperate with the fixture housing and lens to produce a desired lighting pattern.

[0099] In some embodiments, bulb arms may be extendable along or rotatable about a longitudinal axis. For example, **FIG. 20** depicts a bulb arm **204''** extending from a body **202''**
20 of an LED bulb adapter **201''**. Bulb arm **204''** is pivotable about a hinge **244** in a similar manner to bulb arm **204'**. In addition, bulb arm has telescoping segments **245a**, **245b** which allow bulb arm **204''** to be extended or retracted along its longitudinal axis L. Telescoping segment **245b** is slidably received by telescoping segment **245a**. Segments **245a**, **245b** may be secured relative to one another by a set screw **247** in a guide slot **249**.

25 [00100] Moreover, bulb arm **204''** is pivotably mounted to body **202''** such that the bulb arm **204''** can be rotated around its longitudinal axis L. Bulb arm **204''** may, for example, be attached to body **202''** by a threaded connection, such that the threads can hold bulb arm in a range of possible orientations.

[00101] In some embodiments, rather than being retrofitted to an existing fixture, LED bulb adapters may be provided as part of their own specialized fixtures. **FIG. 16** depicts a bottom perspective view, in partial cutaway, of a fixture **1000** with an LED bulb adapter **401** and bulbs **220**. Fixture **1000** has an arched top plate **1002** and two opposing end walls **1004**.
5 Top plate **1002** and end walls **1004** may be formed of a metallic material such as mild steel and may have reflective inner surfaces. The inner surfaces of top plate **1002** and end walls **1004** may, for example, be painted white or silver, or finished with a mirrored surface.

[00102] Fixture **1002** has an arched lens **1006** defining a light enclosure. Lens **1006** may be formed of a translucent plastic or any other suitable translucent or transparent material.
10 Lens **1006** may be selected to cause refraction of light produced by LED bulbs **220** to produce a diffuse lighting pattern. In the depicted embodiment, fixture **1000** is 2 feet wide by 2 feet long. In other embodiments, fixtures **1000** may have the same outer dimensions as common fluorescent lighting fixtures. Accordingly, fixtures **1000** may be usable in place of fluorescent fixtures in standard ceiling designs, such as standard suspended ceiling
15 patterns.

[00103] In some embodiments, LED bulb adapters and LED bulbs may be installed in high-bay fixtures. For example, some high-bay fluorescent lighting fixtures may be designed to accommodate one or more ballasts, and a large number of tubes (e.g. 8 or more). Moreover, high-bay fluorescent fixtures may be designed to accommodate relatively high-wattage fluorescent tubes, such as 55W T5 tubes. High-bay fluorescent fixtures may be designed to be powered by relatively high mains voltage, e.g. 347V AC. In such
20 embodiments, multiple LED bulb adapters **201**, **401** may be installed in a single fixture.

[00104] LED bulb adapters **201**, **401** may also be installed to fluorescent strip lighting fixtures designed to accommodate exposed fluorescent tubes, i.e. to receive fluorescent tubes without enclosing them behind a lens. In such fixtures, fluorescent tube holders may be mounted directly to a ballast cover. LED bulb adapters **201**, **401** may be retrofitted to such fixtures by removing the tube holders, removing the ballast cover and ballast, wiring an LED bulb adapter **201**, **401** and attaching it to the ballast cover, and re-attaching the ballast cover to the fixture.
25

[00105] In still other embodiments, LED bulb adapters may be installed in high-pressure sodium lamp fixtures. For example, **FIG. 17** shows a typical high-pressure wall pack fixture **2000**. As will be apparent, wall pack fixture **2000** is much shorter than fluorescent tube fixture **100**.

5 [00106] **FIG. 18** shows an example LED bulb adapter **501** configured for installation to wall pack fixture **2000**. LED bulb adapter **501** is similar to LED bulb adapter **401** except that LED bulb adapter **501** has multiple bulb arms **204** extending from a single side of its body **502**, rather than from opposite ends.

[00107] **FIG. 19** shows a schematic diagram of an electrical configuration of a typical high-
10 pressure sodium wall pack fixture, with a high-pressure sodium lamp **2009** driven by a ballast **2001** and starter **2003** connected to and mains supply lines **2005**. To retrofit LED bulb adapter **501**, ballast **2001**, starter **2003** and high-pressure sodium lamp **2009** are disconnected or disconnected and physically removed. Wires of LED bulb adapter **501** are connected to mains supply lines **2005**.

15 [00108] In addition to wall-pack high-pressure sodium fixtures, LED bulb adapters may be configured for installation to high-bay high pressure sodium fixtures. Such fixtures may be designed for mounting in a high elevated location above an area to be illuminated. For example, high-bay fixtures may be mounted at an elevation above a warehouse floor. High-bay fixtures designed for high-pressure sodium bulbs may have, for example downwardly-
20 opening dome, frustoconical or bell shapes and may include a ballast and starter as depicted in **FIG. 19**. LED bulb adapters designed for such fixtures may have bulb arms that extend downwardly and outwardly to match the shape of the fixture.

[00109] In other embodiments, LED bulb adapters may be installed to other types of lighting fixtures, such as signage fixtures, pole lamps, and the like.

25 [00110] The following discussion provides many example embodiments. Although each embodiment represents a single combination of inventive elements, other examples may include all possible combinations of the disclosed elements. Thus if one embodiment

comprises elements A, B, and C, and a second embodiment comprises elements B and D, other remaining combinations of A, B, C, or D, may also be used.

[00111] The term "connected" or "coupled to" may include both direct coupling (in which two elements that are coupled to each other contact each other) and indirect coupling (in which at least one additional element is located between the two elements).

[00112] Although the embodiments have been described in detail, it should be understood that various changes, substitutions and alterations can be made herein.

[00113] Moreover, the scope of the present application is not intended to be limited to the particular embodiments of the process, machine, manufacture, composition of matter, means, methods and steps described in the specification. As one of ordinary skill in the art will readily appreciate from the disclosure of the present invention, processes, machines, manufacture, compositions of matter, means, methods, or steps, presently existing or later to be developed, that perform substantially the same function or achieve substantially the same result as the corresponding embodiments described herein may be utilized. Accordingly, the appended claims are intended to include within their scope such processes, machines, manufacture, compositions of matter, means, methods, or steps

[00114] As can be understood, the examples described above and illustrated are intended to be exemplary only. The invention is defined by the appended claims.

WHAT IS CLAIMED IS:

1. A method of retrofitting a fluorescent tube light fixture with an LED bulb adapter the fluorescent tube fixture originally having a ballast, a fluorescent tube receptacle for receiving pins of a fluorescent tube, and an enclosure defined by a reflector housing and a lens, the method comprising:

removing said lens from said reflector housing;

disconnecting said ballast from a mains power supply line and removing said ballast and said fluorescent tube receptacle from said housing to expose a mains power supply line entry point in the reflector housing;

providing a LED bulb adapter comprising a body defining an electrical enclosure, the body having a mounting flange defining a central opening to receive said mains power supply line, the body having a plurality of bulb arms extending from the body, each bulb arm mounting an Edison socket light-emitting diode (LED) bulb socket;

wiring said mains power supply line to the plurality of Edison socket light-emitting diode (LED) bulb sockets extending from the body of the LED bulb adapter, defining an electrical junction box, said bulb sockets configured to distribute light from said LED bulbs across said lens and said reflector;

securing the mounting flange on a surface of the reflector housing;

threading a plurality of LED bulbs into said bulb sockets;

installing said lens to said housing such that said LED bulb adapter is received in an enclosure defined by said housing and said lens.

2. The method of claim 1, wherein said wiring comprises removing a knock-out panel on said body of the LED bulb adapter and threading a wire through said knock-out panel.

3. The method of claim 1, further comprising attaching said mounting flange to said surface of the reflector housing using self-tapping fasteners.

4. The method of claim 1, comprising attaching a diffuser grate to at least one bulb arm.

5. The method of claim 1, wherein said body defining an electrical junction box is mounted inside said housing, opposing another electrical junction box outside said housing.

6. The method of claim 1, wherein the mounting flange abuts the surface of the reflective housing to position the central opening in alignment with said mains power supply line entry point.

7. A bulb adapter for retrofitting a fluorescent tube light fixture with an LED bulb adapter the fluorescent tube fixture originally having a ballast, a fluorescent tube receptacle for receiving pins of a fluorescent tube, and an enclosure defined by a reflective housing and a lens, said LED bulb adapter comprising:

a body defining an electrical junction box;

a plurality of bulb arms extending in different directions from said body, each bulb arm mounting an LED bulb socket to hold LED bulbs in a generally planar arrangement inside said enclosure;

a mounting flange defining an central opening in said body for receiving a mains power supply line to connect said mains power supply line to said LED bulb sockets, said mounting flange for securing said body on a surface of said reflector housing so that said LED bulbs distribute light across said reflective housing and said lens, wherein said central opening is configured to provide clearance such that said body and mains power supply line need not be aligned, wherein said surface comprises a mains power supply line entry point.

8. The bulb adapter of claim 7, wherein said body comprises at least one knock-out panel removable from said body by manual application of pressure to define a wiring pass-through.

9. The bulb adapter of claim 7, wherein said body is formed from a polymer.

10. The bulb adapter of claim 7, wherein said body is formed from polyvinyl chloride (PVC).

11. The bulb adapter of claim 7, comprising a first pair of bulb arms each mounting an LED bulb socket extending from said body on opposite sides.

12. The bulb adapter of claim 11, comprising a second pair of bulb arms each mounting an LED bulb socket extending from said body on opposite sides, wherein said first pair of bulb arms and said second pair of bulb arms are generally perpendicular to one another.

13. The bulb adapter of claim 7, wherein said bulb sockets are sockets for receiving an LED bulb with a standard medium size threaded base.

14. The bulb adapter of claim 7, comprising a light diffuser mounted to at least one of said bulb arms.

15. The bulb adapter of claim 14, wherein said light diffuser defines a lattice pattern and has a reflective surface.

16. The bulb adapter of claim 14, wherein said light diffuser is releasably attached to said bulb socket with a clip.

17. The bulb adapter of claim 14, wherein said light diffuser has a plurality of inclined diffractive surfaces at an angle to one another.

18. A light fixture comprising the bulb adapter of claim 7, mounted within an enclosure defined by a reflector housing and a lens.

19. The light fixture of claim 18, wherein said body defining an electrical junction box is mounted inside said housing, opposing another electrical junction box outside said housing.

20. The bulb adapter of claim 7, wherein said central opening is configured to abut the surface of the reflective housing to position the central opening in alignment with said mains power supply line entry point.

1/21

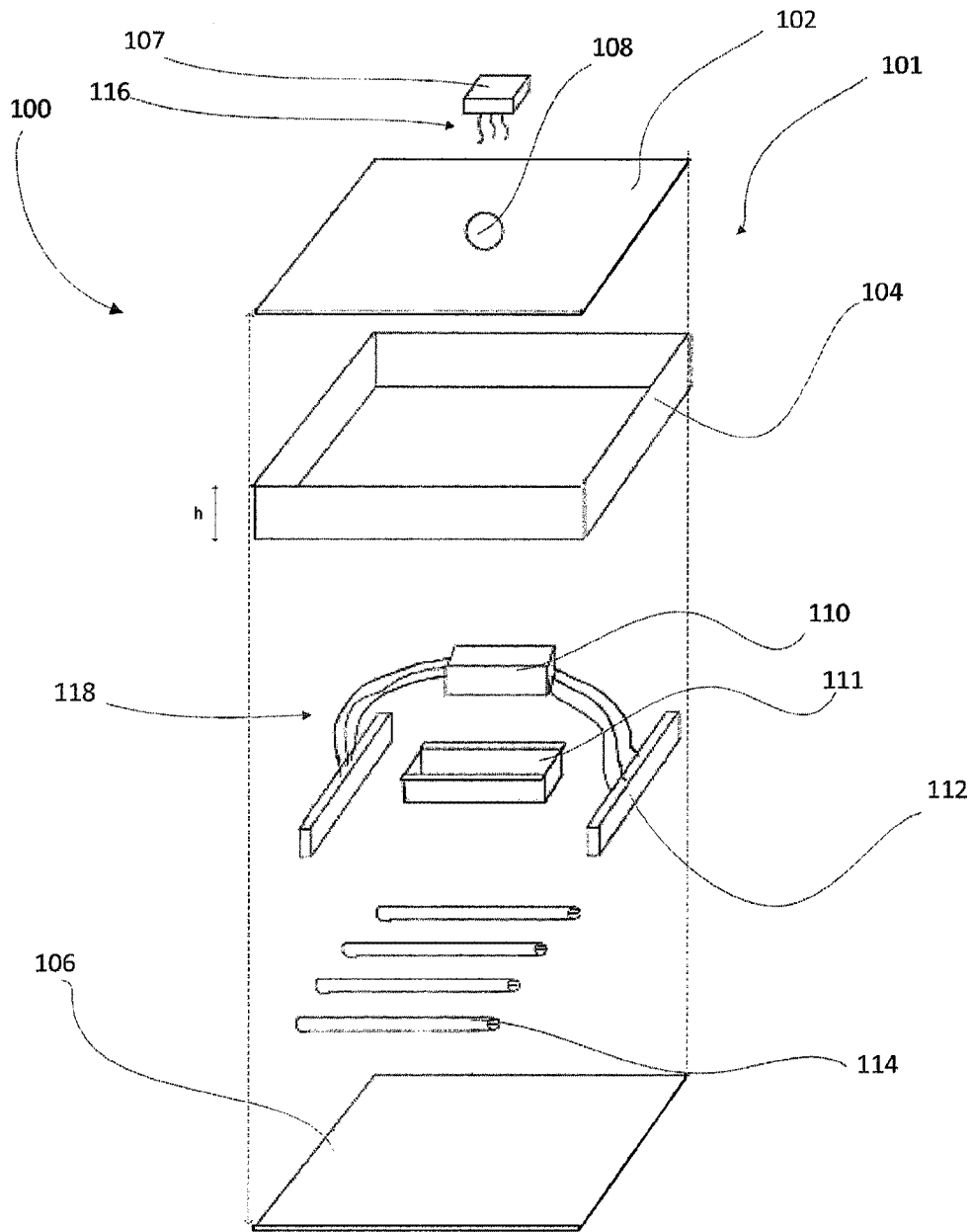

FIG. 1

2/21

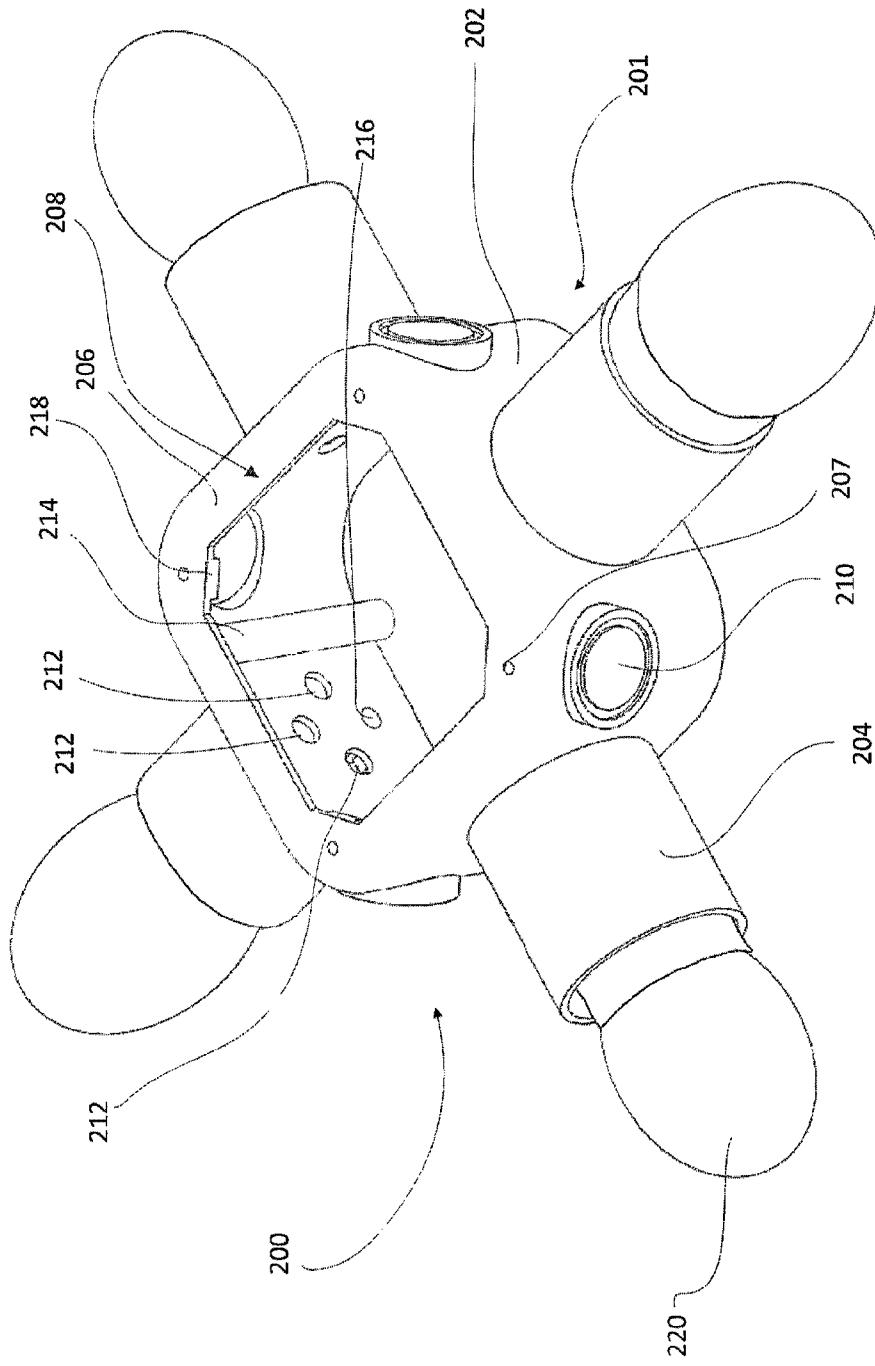

FIG. 2

3/21

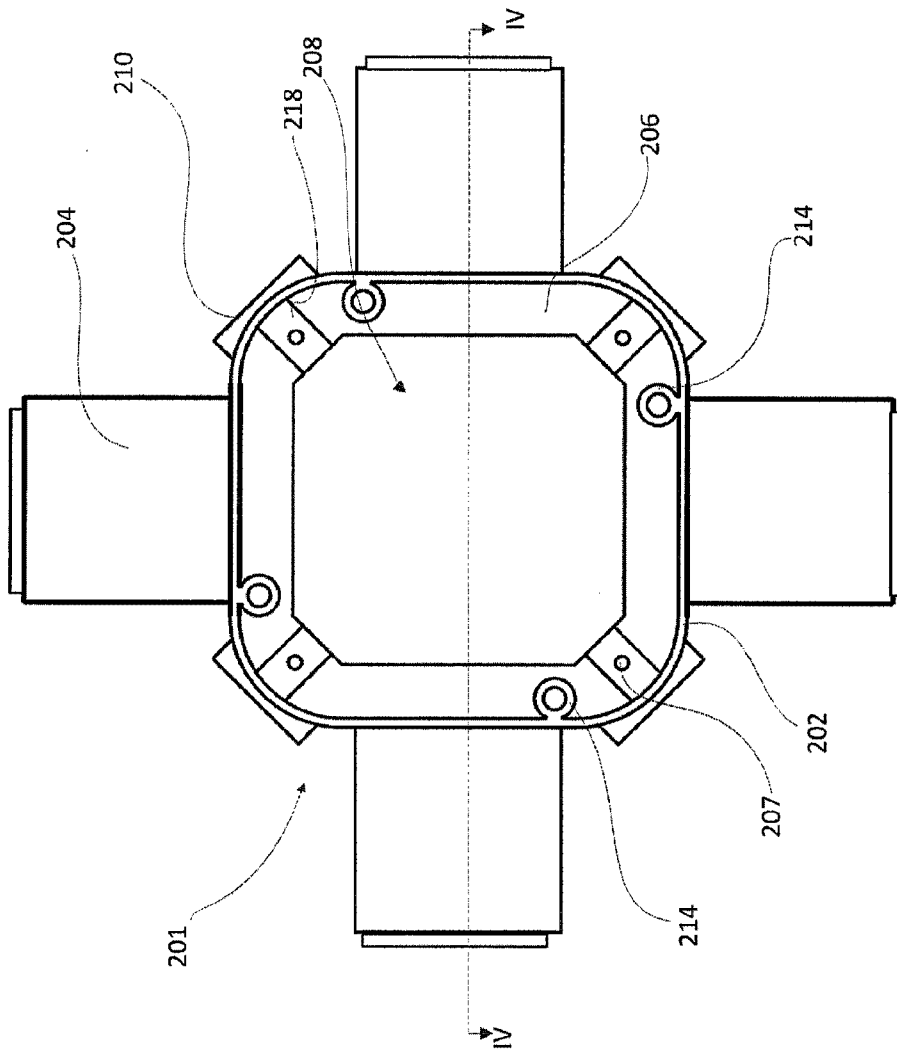

FIG. 3

4/21

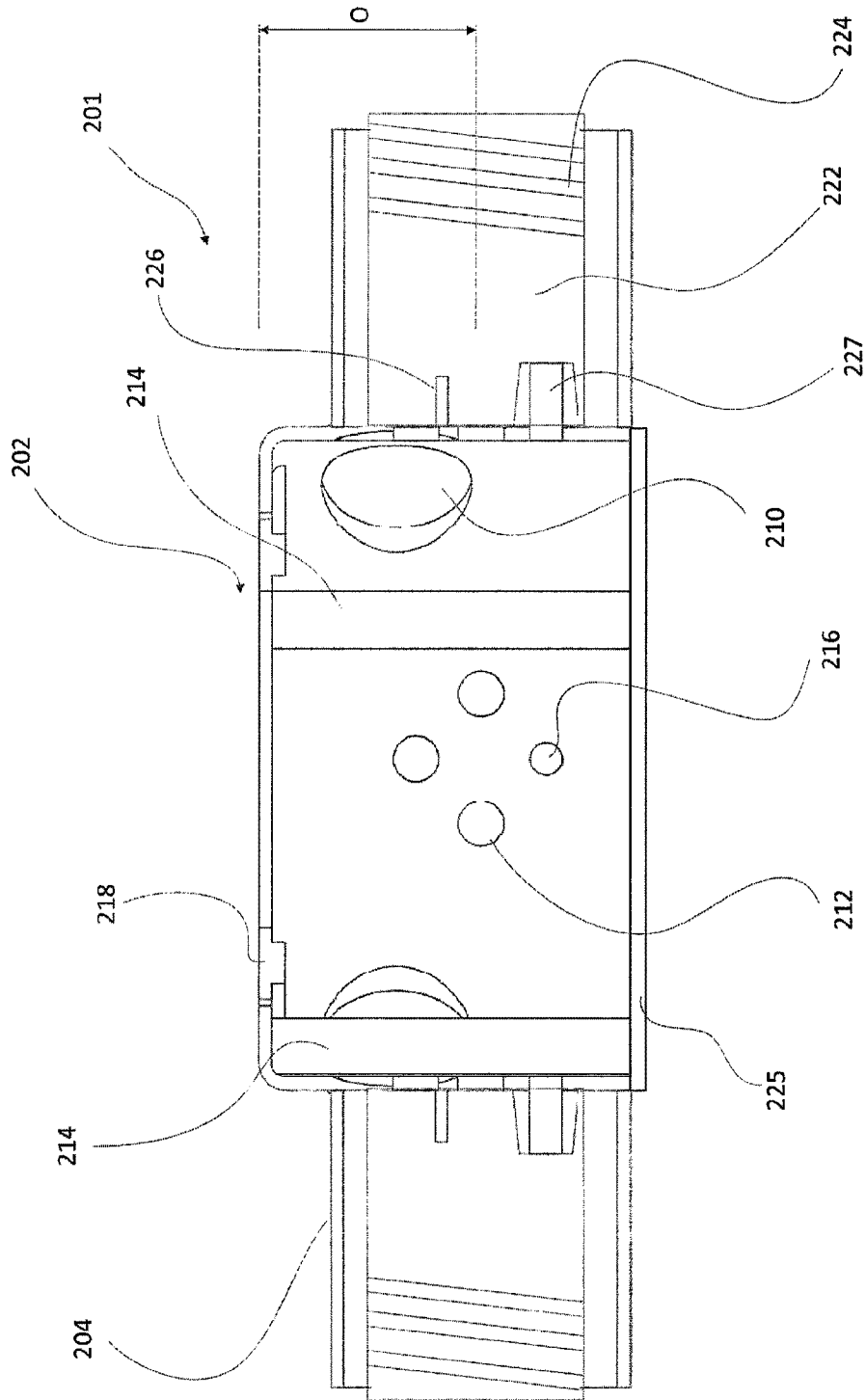

FIG. 4

5/21

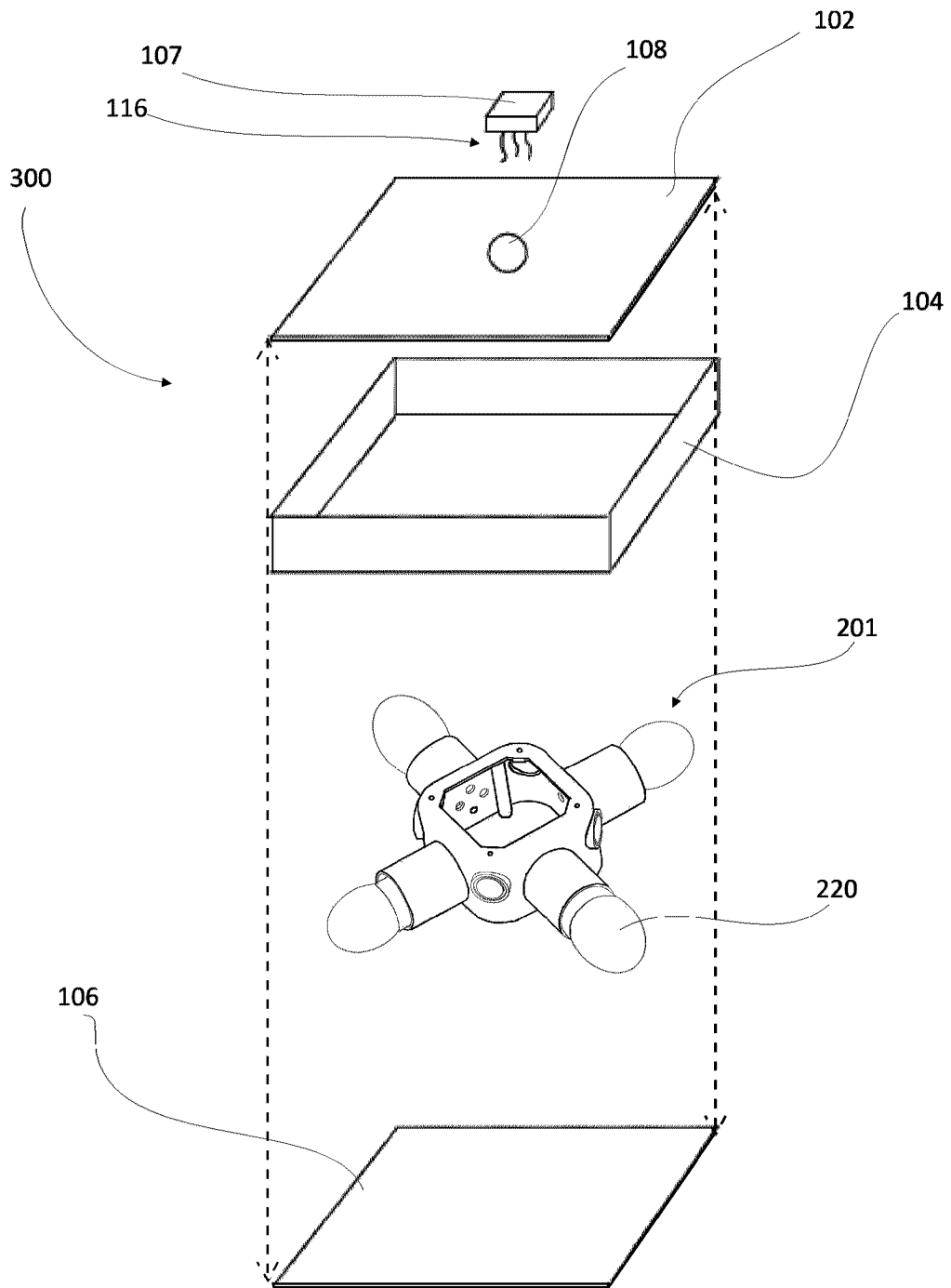

FIG. 5

6/21

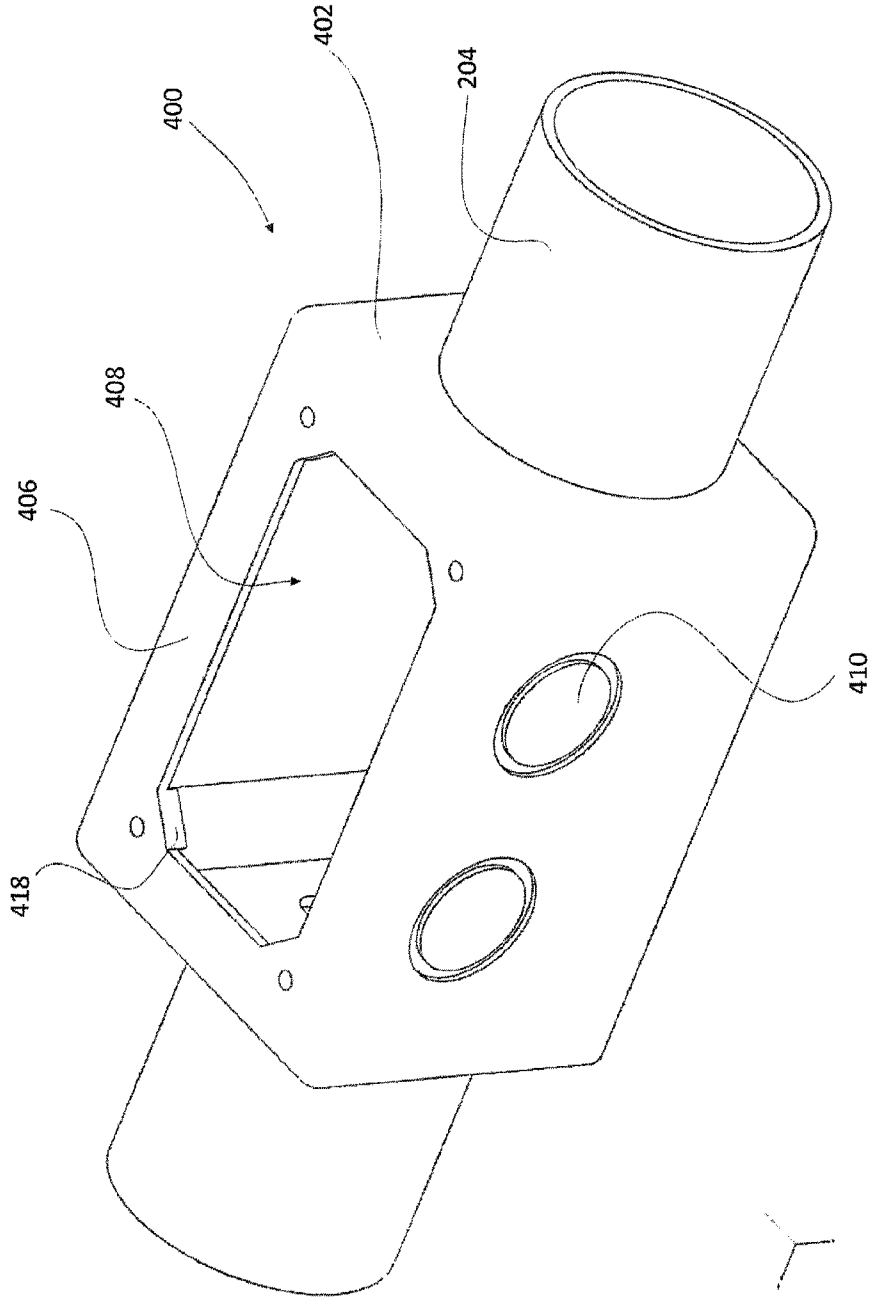

FIG. 6

7/21

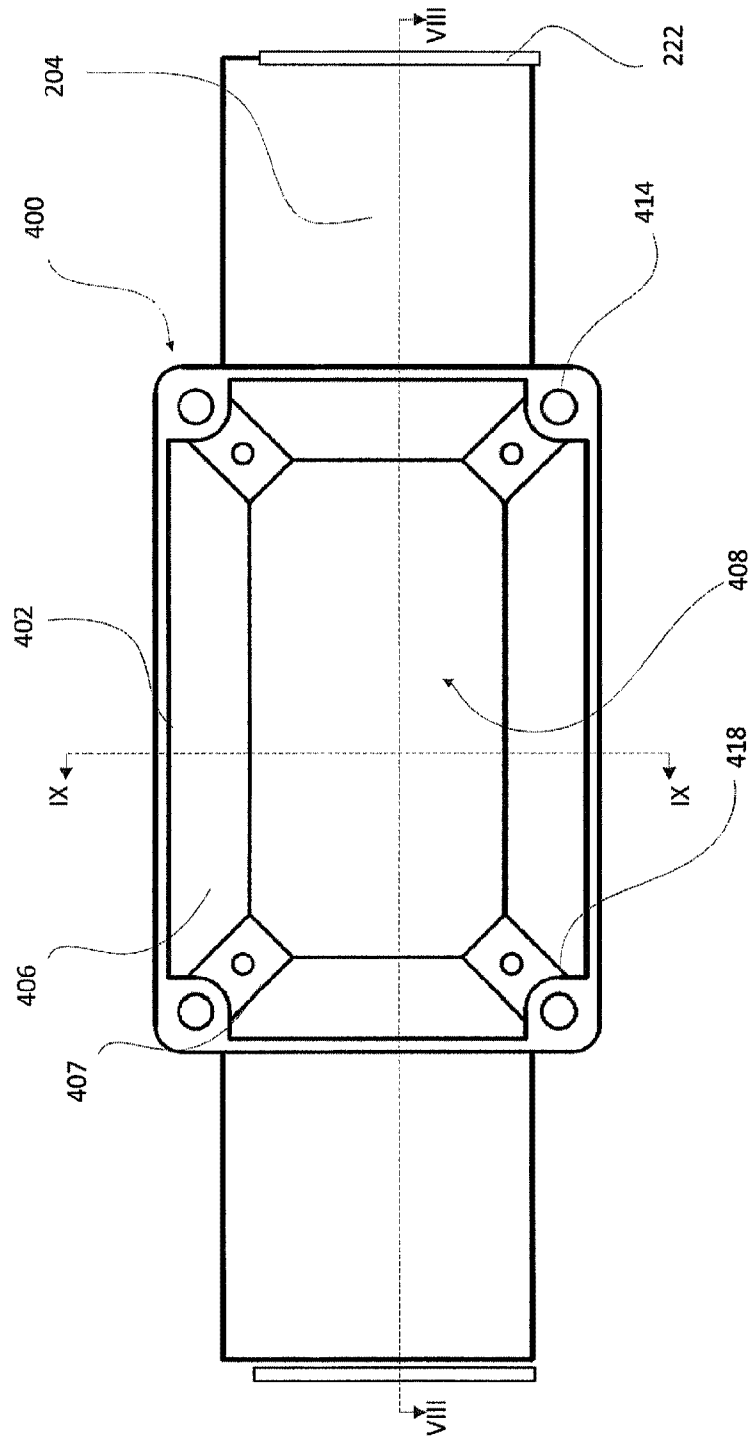

FIG. 7

8/21

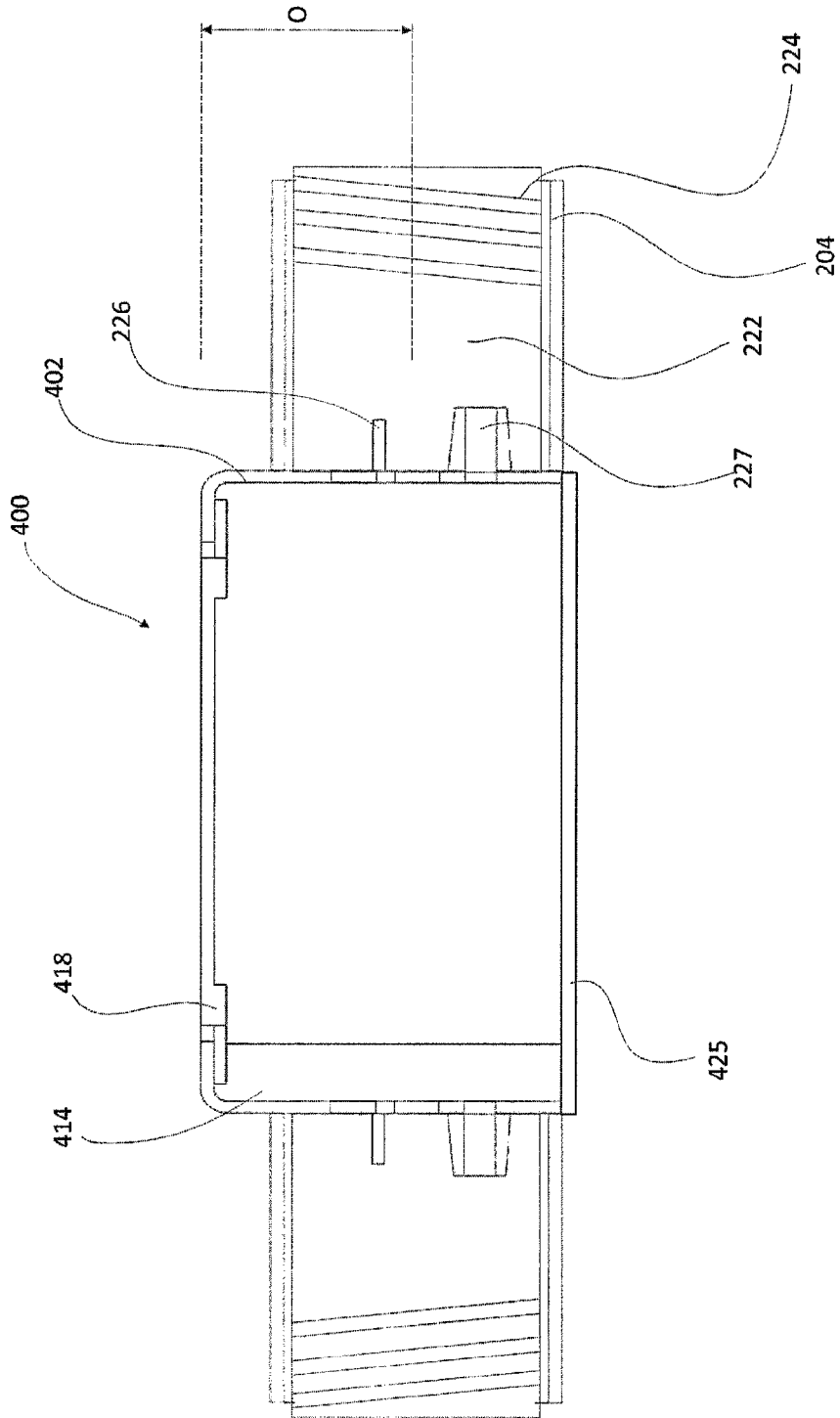

FIG. 8

9/21

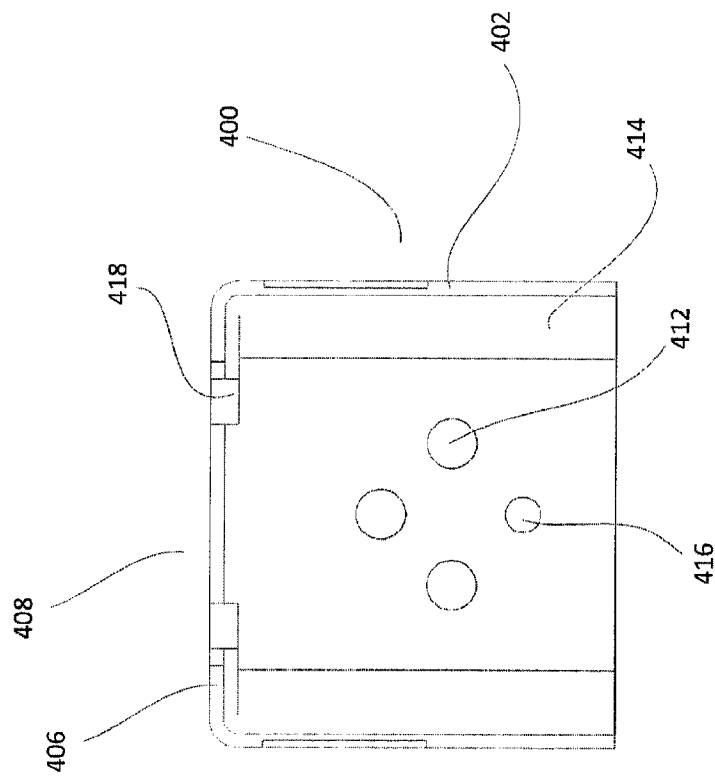

FIG. 9

10/21

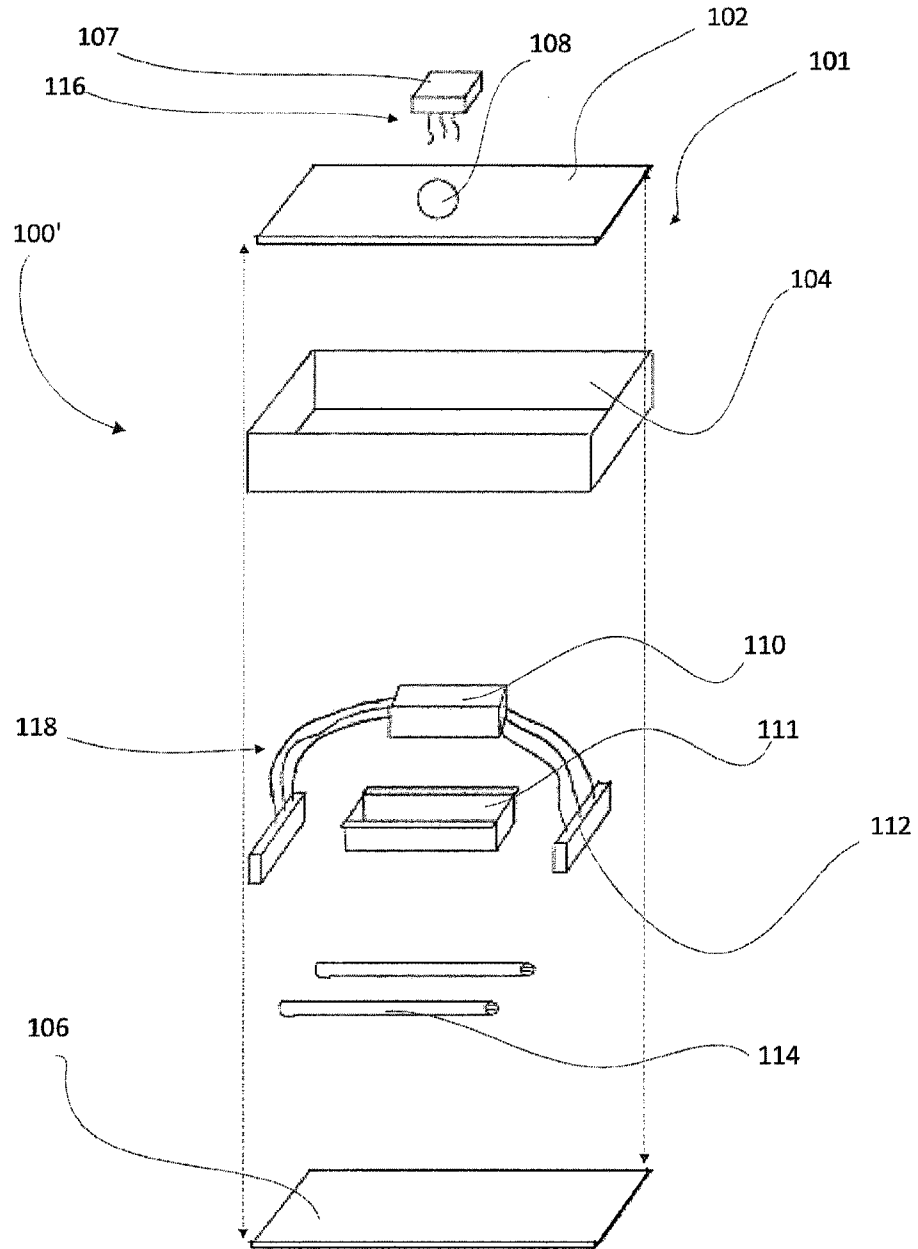

FIG. 10

11/21

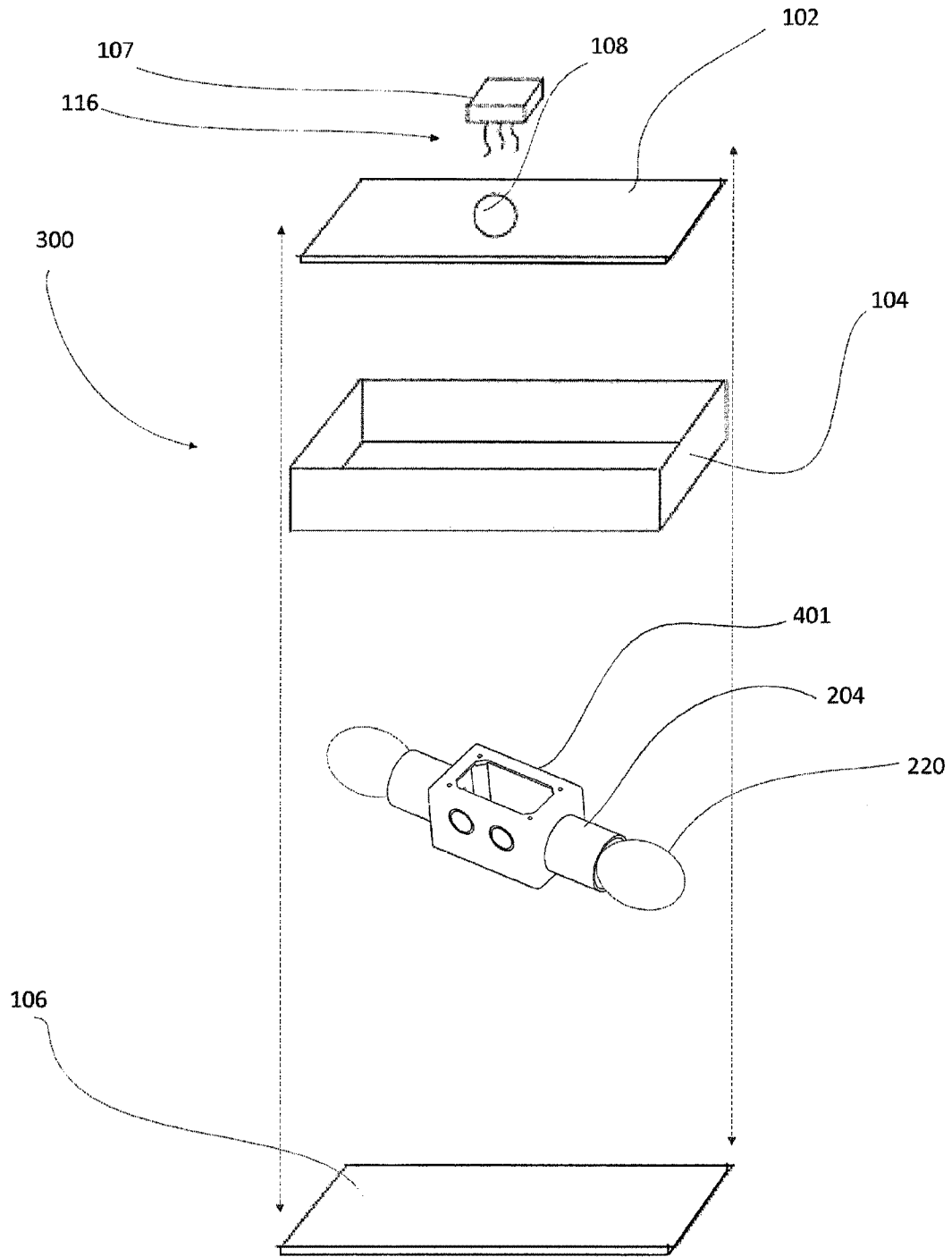

FIG. 11

12/21

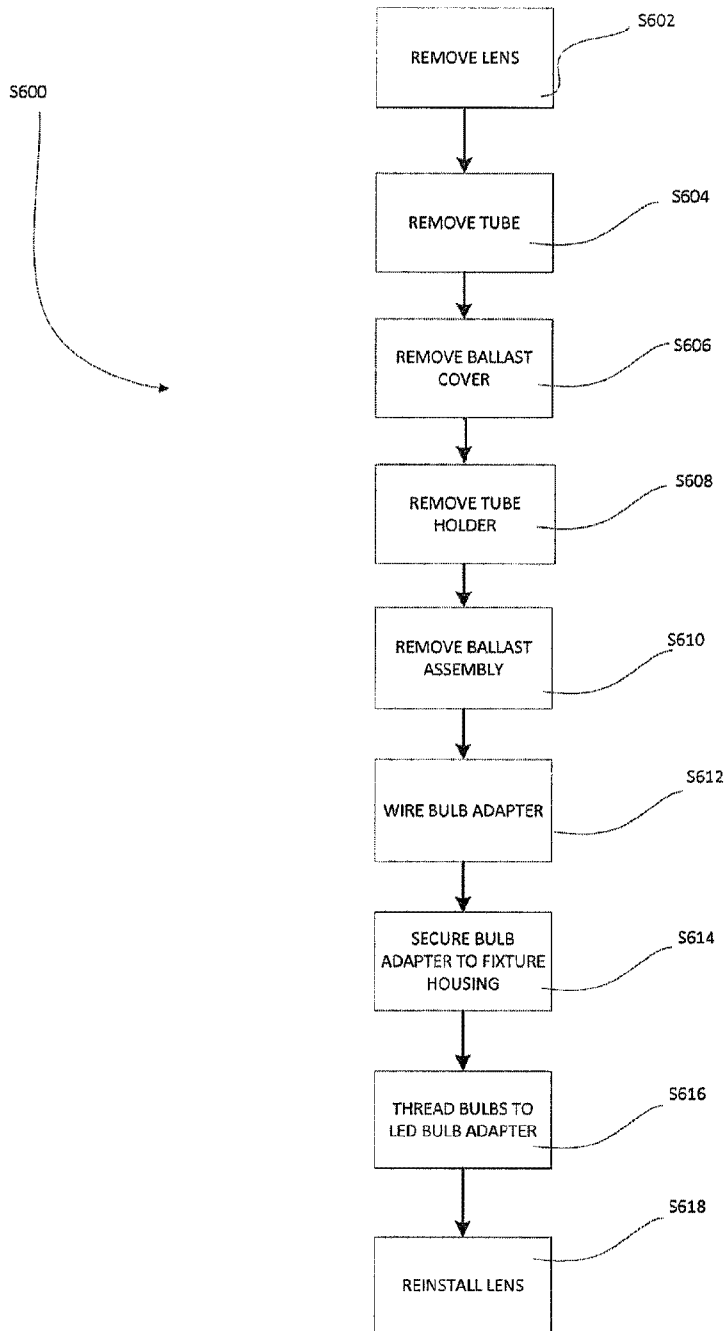

FIG. 12

13/21

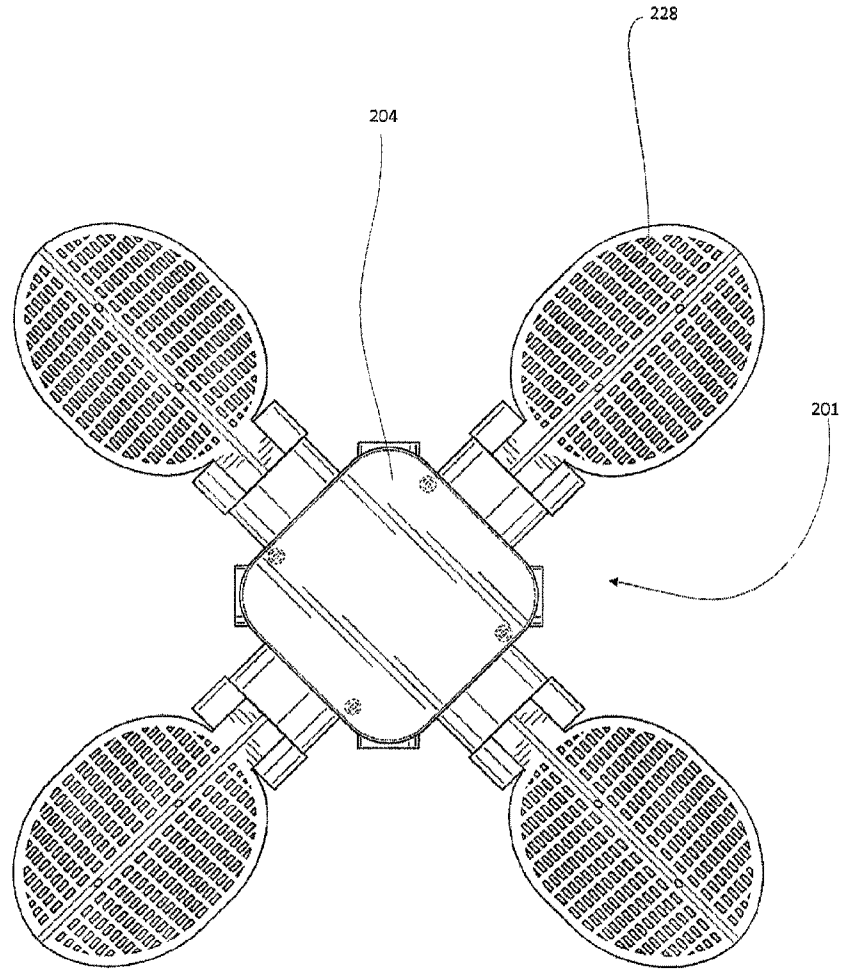

FIG. 13

14/21

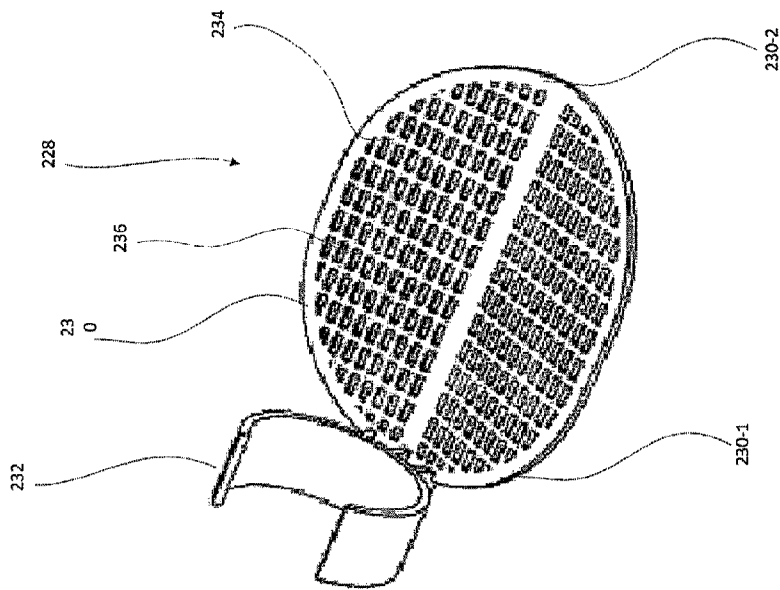

FIG. 14A

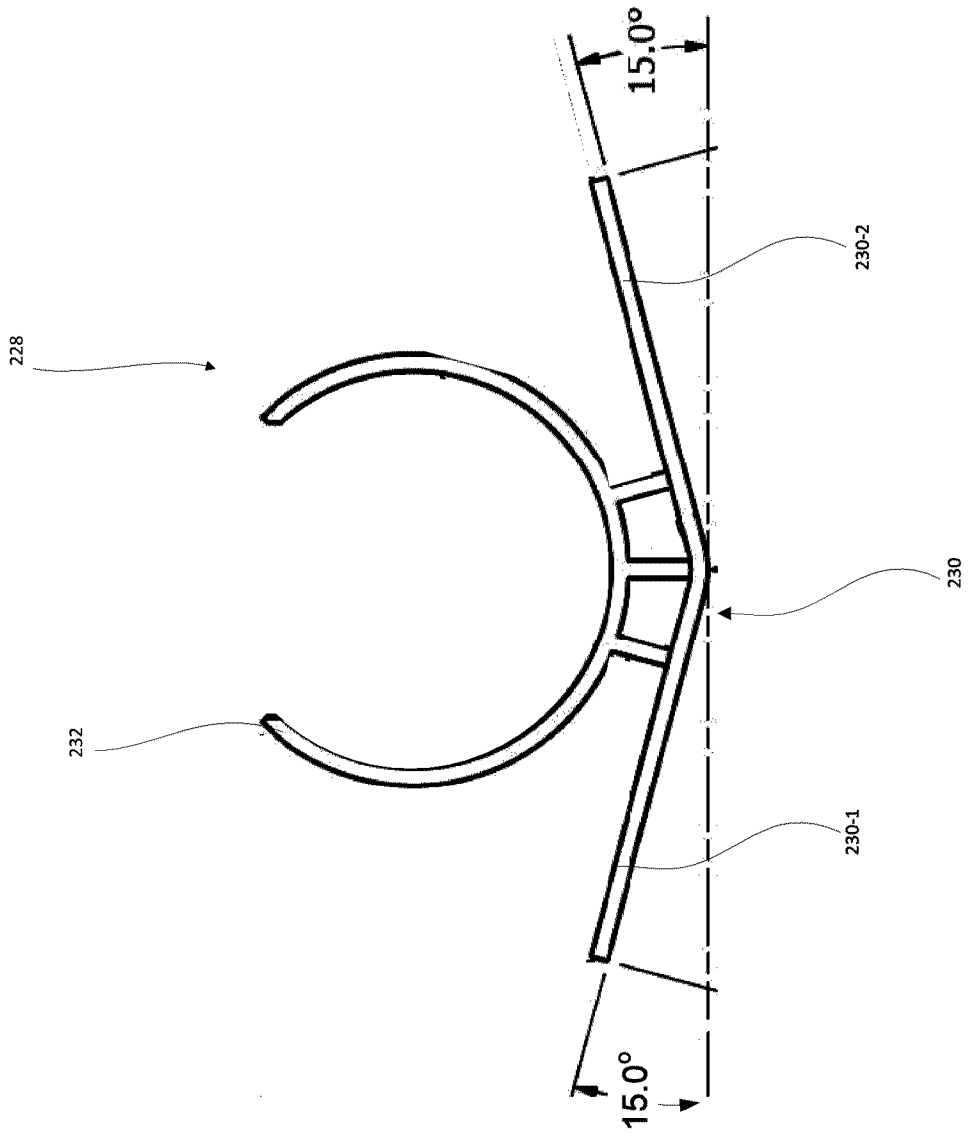

FIG. 14B

16/21

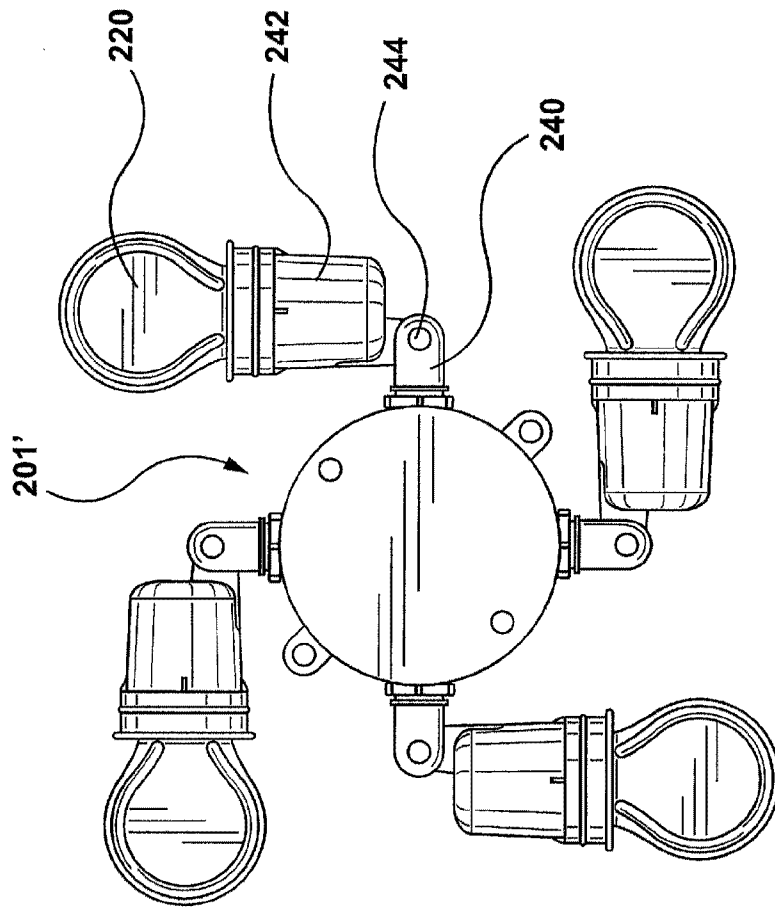

FIG. 15

17/21

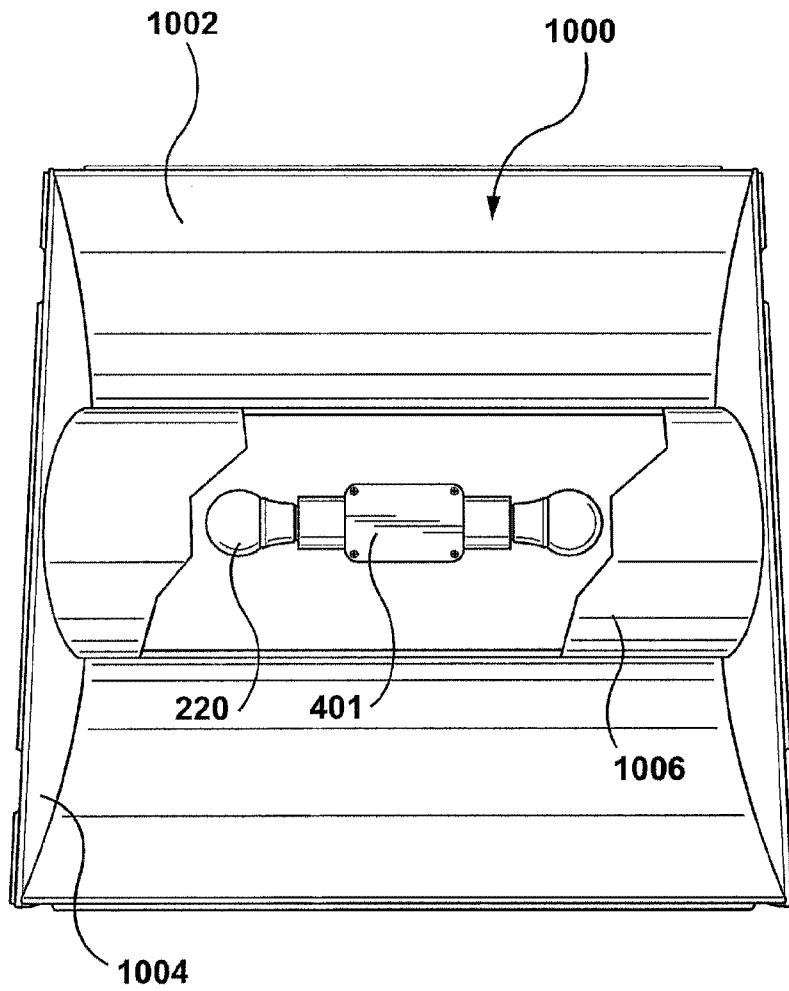

FIG. 16

18/21

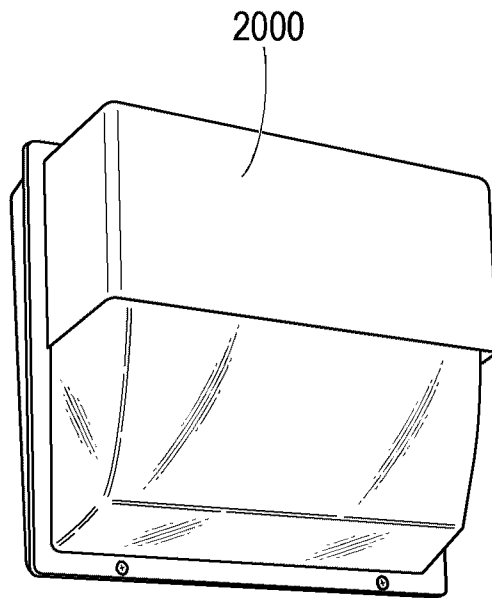

FIG. 17

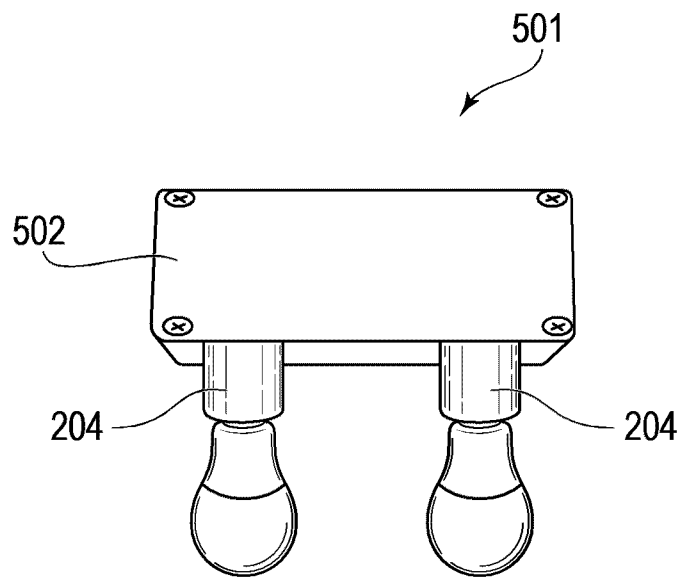

FIG. 18

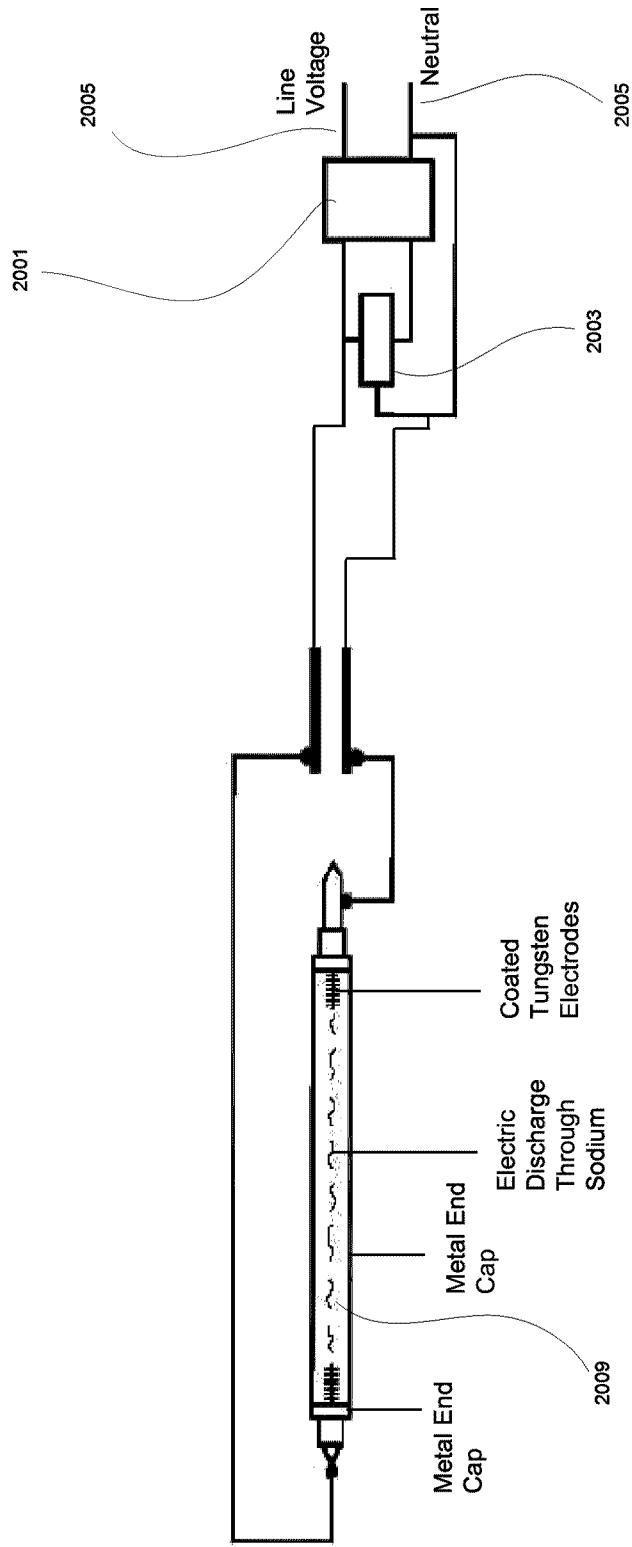

FIG. 19

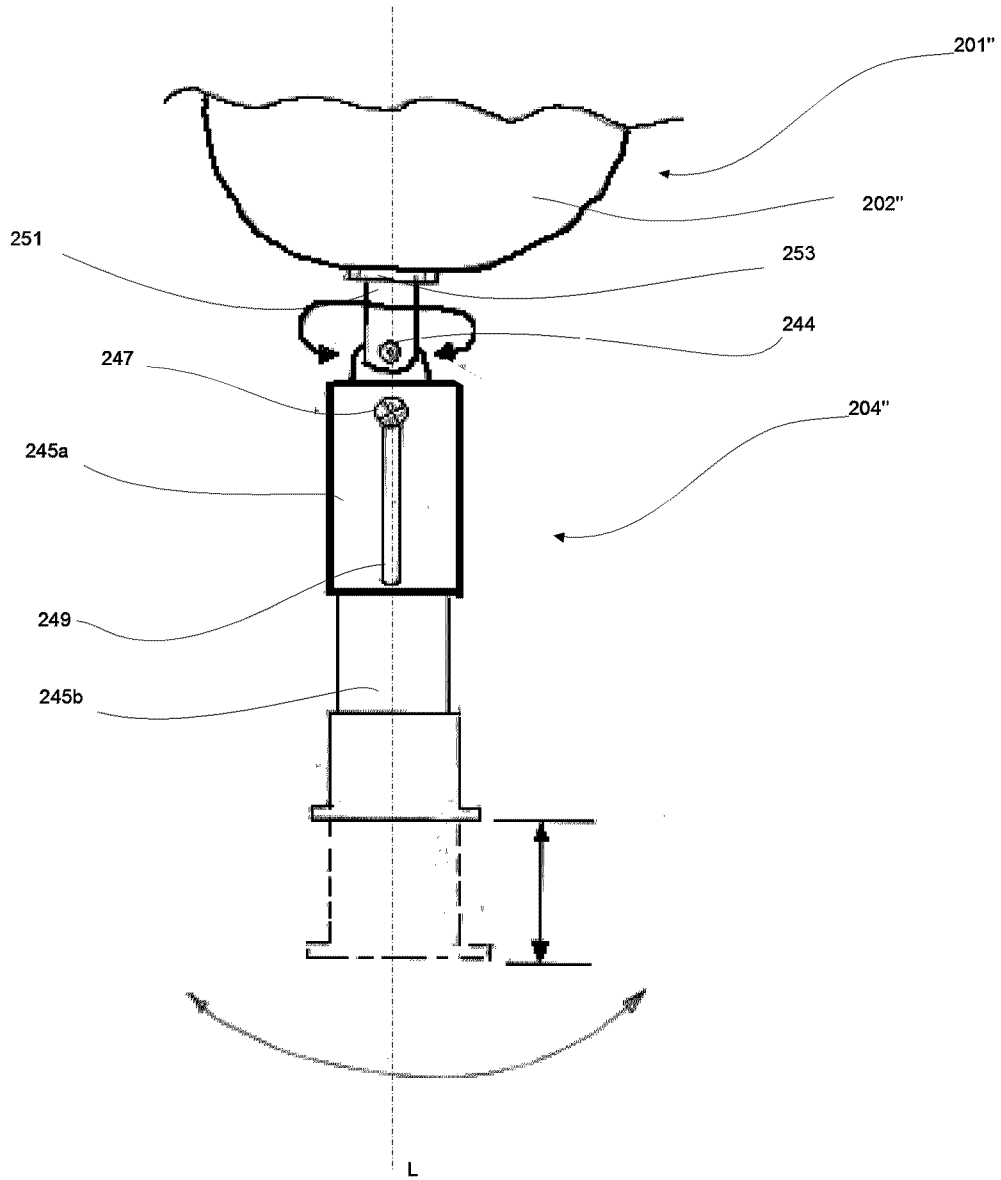

FIG. 20

