



US00D958988S

(12) **United States Design Patent**
Bayan

(10) **Patent No.:** **US D958,988 S**

(45) **Date of Patent:** **** Jul. 26, 2022**

(54) **INNER BLADE HUB**

(71) Applicant: **Nami Bayan**, Shelton, CT (US)

(72) Inventor: **Nami Bayan**, Shelton, CT (US)

(**) Term: **15 Years**

(21) Appl. No.: **29/669,704**

(22) Filed: **Nov. 9, 2018**

Related U.S. Application Data

(63) Continuation-in-part of application No. 15/988,556, filed on May 24, 2018, now abandoned.

(51) **LOC (13) Cl.** **24-02**

(52) **U.S. Cl.**
USPC **D24/146**

(58) **Field of Classification Search**

USPC D28/56, 57, 59, 62, 44, 7, 9; D8/107, D8/14, 98-100, 300, 17, 20, 47, 98-99; D10/126; D23/223; D24/108, 112-115, D24/117-122, 127, 133, 146-149, 151, D24/172-176, 214, 231; D7/649, 669
CPC A61B 10/0266; A61B 17/3205; A61B 17/32053; A61B 2010/0208; A61B 2017/0076; A61B 2090/034; A61B 2090/0811; A61B 2017/00367; A61B 17/06; A61B 17/20; A61B 17/062; A61B 17/00; A61B 17/3211; A61B 2017/00761; A61B 2017/32113; A61B 2018/1422; A61B 5/6833; A61B 17/34; A61B 17/32; A61B 17/16; A61B 2018/00607; A61B 2018/00601; A61B 17/14; A61B 10/0275; A61B 2217/005; A61B 5/150213; A61B 5/150351; A61B 5/150352; A61B 90/11; A61M 37/00; A61M 16/0472; A61M 3/00; A61M 1/0039; A61M 1/0064; A61M 5/20; A61M 5/31; A61M 5/178; A61M 5/3129; A61M 5/3146; A61M 5/3148; A61M

(Continued)

(56) **References Cited**

U.S. PATENT DOCUMENTS

D302,590 S * 8/1989 Trott D24/147
D315,793 S * 3/1991 Trott D24/147
D753,980 S * 4/2016 Arthurs D8/300

(Continued)

OTHER PUBLICATIONS

Biopsy Punch Acu-Excisor Dermal 6x12 mm OR Grade, mckesson.com, [online], [site visited Dec. 16, 2021], Available from internet URL: <https://mms.mckesson.com/product/320297/Acuderm-PE625> (Year: 2021).*

(Continued)

Primary Examiner — Samantha Q Lawrence

Assistant Examiner — Holly M Rodriguez

(57) **CLAIM**

The ornamental design for an inner blade hub, as shown and described.

DESCRIPTION

FIG. 1 is a top perspective view of an inner blade hub; FIG. 2 is a bottom perspective view thereof; FIG. 3 is a top plan view thereof; FIG. 4 is a bottom plan view thereof; FIG. 5 is a left-side elevational view thereof; FIG. 6 is a right-side elevational view thereof; FIG. 7 is a cross-sectional view thereof taken along line 7-7 of FIG. 3; and, FIG. 8 is a top perspective view thereof being integrated into a height-adjustable skin excision biopsy device. The broken line showing of a push tab, a pair of engaging teeth, and a plurality of sliding tabs in FIGS. 1-7, and the broken line showing of an outer hub and a hollow cylindrical handle in FIG. 8 are included for the purpose of showing environmental structure and forms not part of the claimed design.

1 Claim, 8 Drawing Sheets

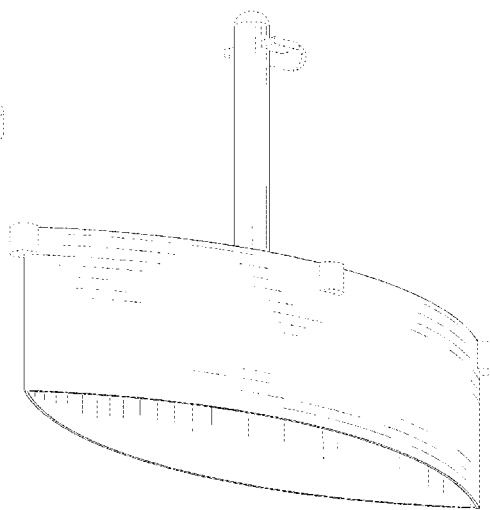
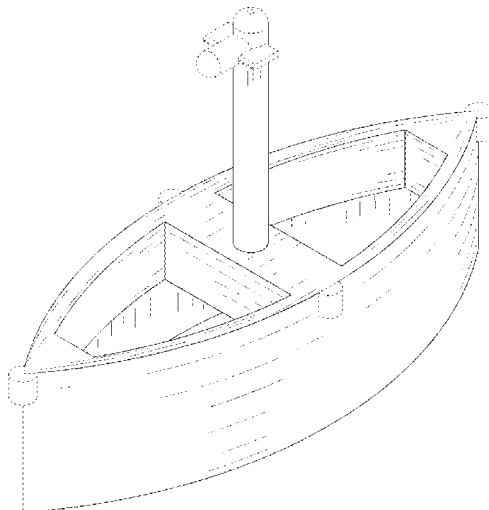

(58) **Field of Classification Search**

CPC 5/3287; A61H 15/00; B26B 5/00; A61F
5/0106; A61F 5/0123

See application file for complete search history.

(56) **References Cited**

U.S. PATENT DOCUMENTS

D926,378 S * 7/2021 Liang D28/57
2019/0110780 A1 * 4/2019 Bayan A61B 17/3205

OTHER PUBLICATIONS

Design of an Elliptical Biopsy Punch a Major Qualifying Project Report, web.wpi.edu [online], [site visited Dec. 16, 2021], Available from internet URL: https://web.wpi.edu/Pubs/E-project/Available/E-project-043009-155135/unrestricted/DSTMQP_Plastipunch.pdf (Year: 2021).*

* cited by examiner

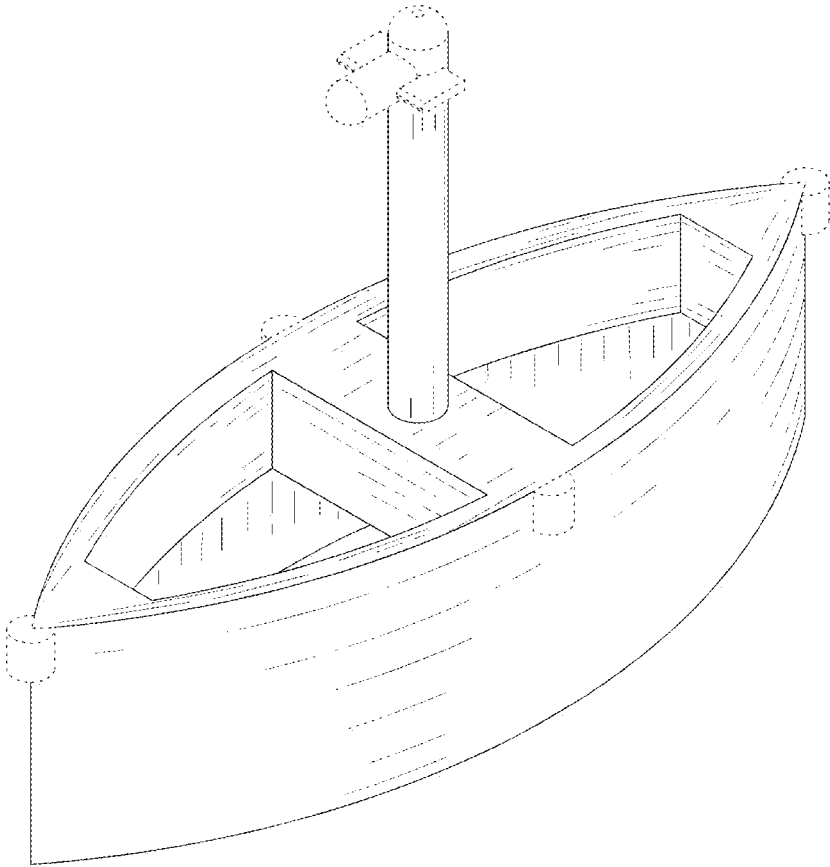

FIG. 1

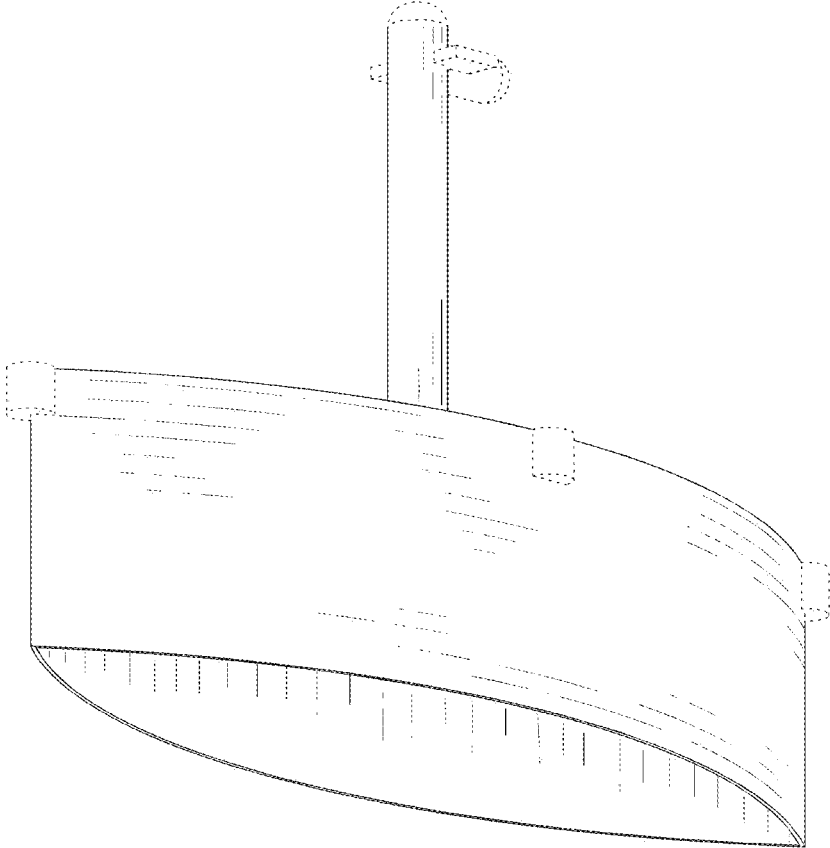

FIG. 2

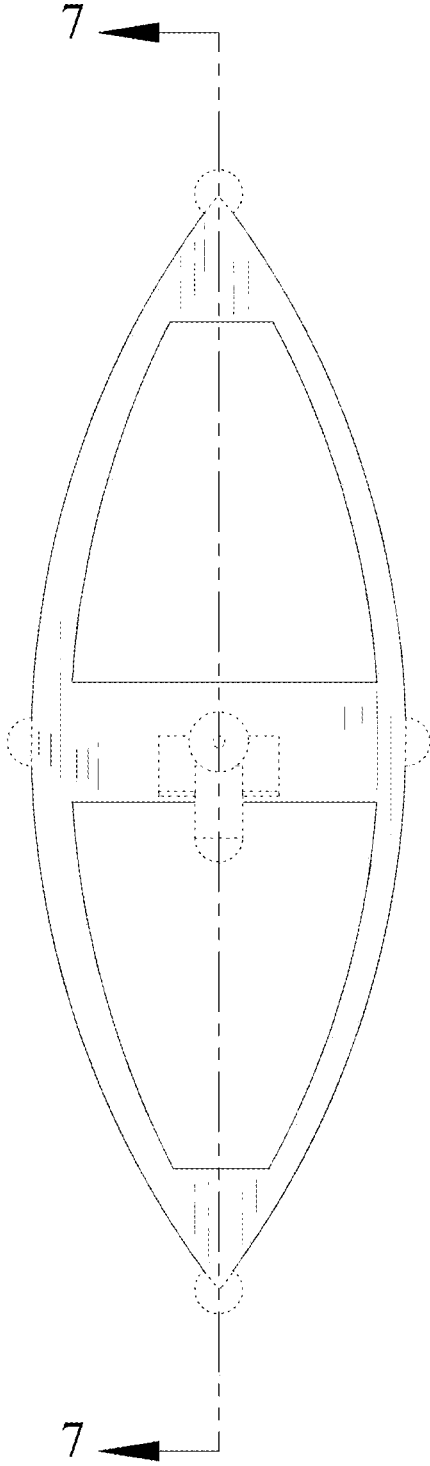

FIG. 3

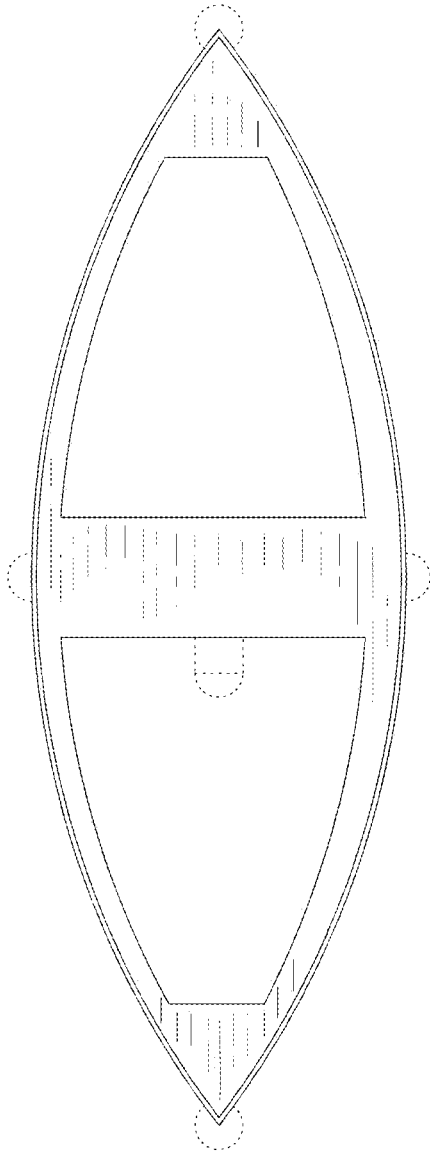

FIG. 4

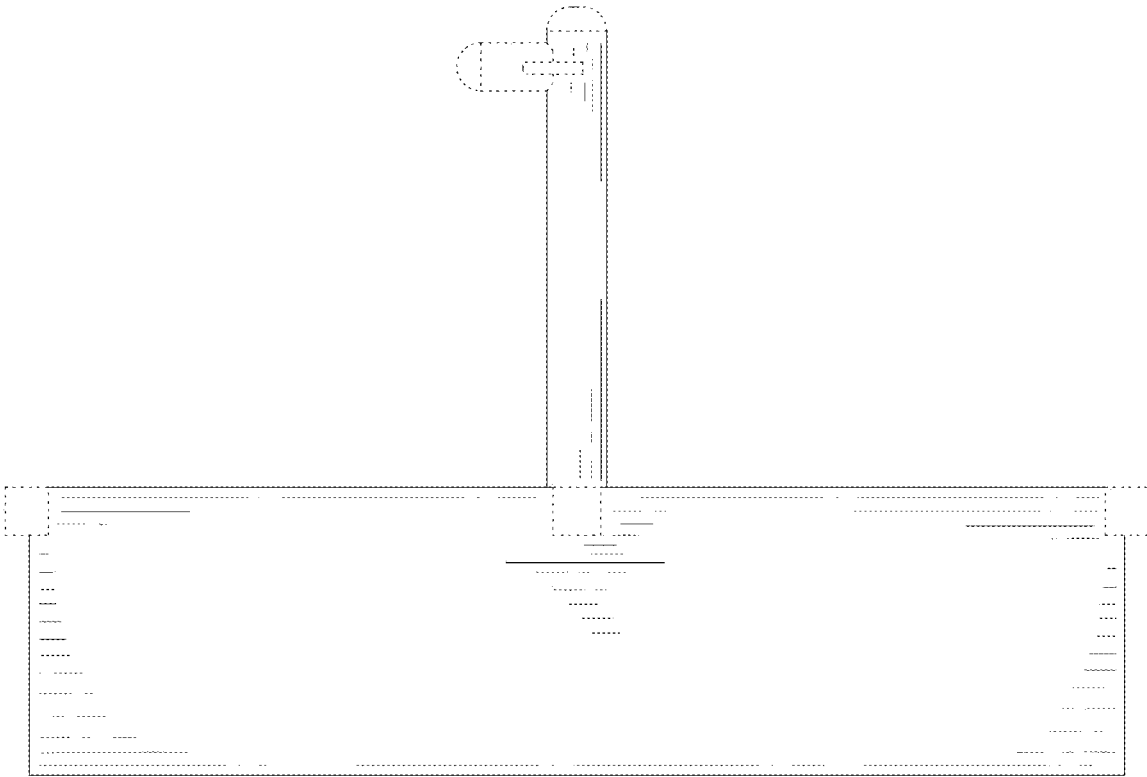

FIG. 5

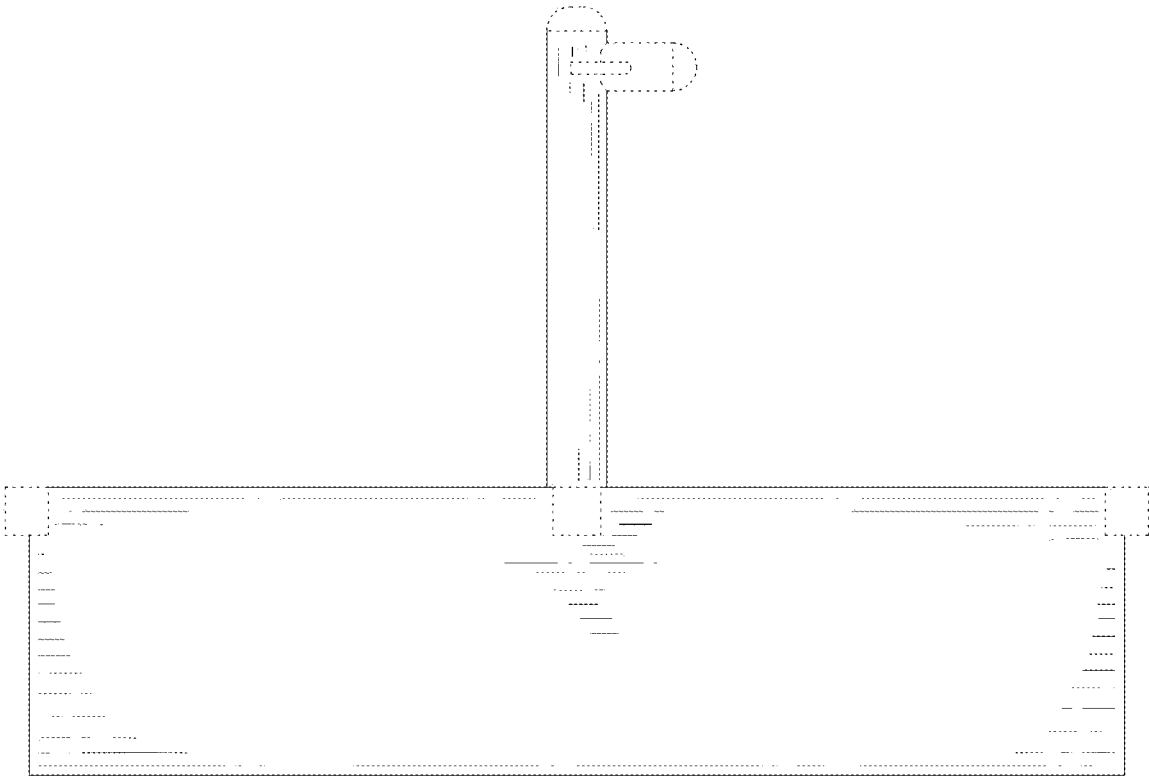

FIG. 6

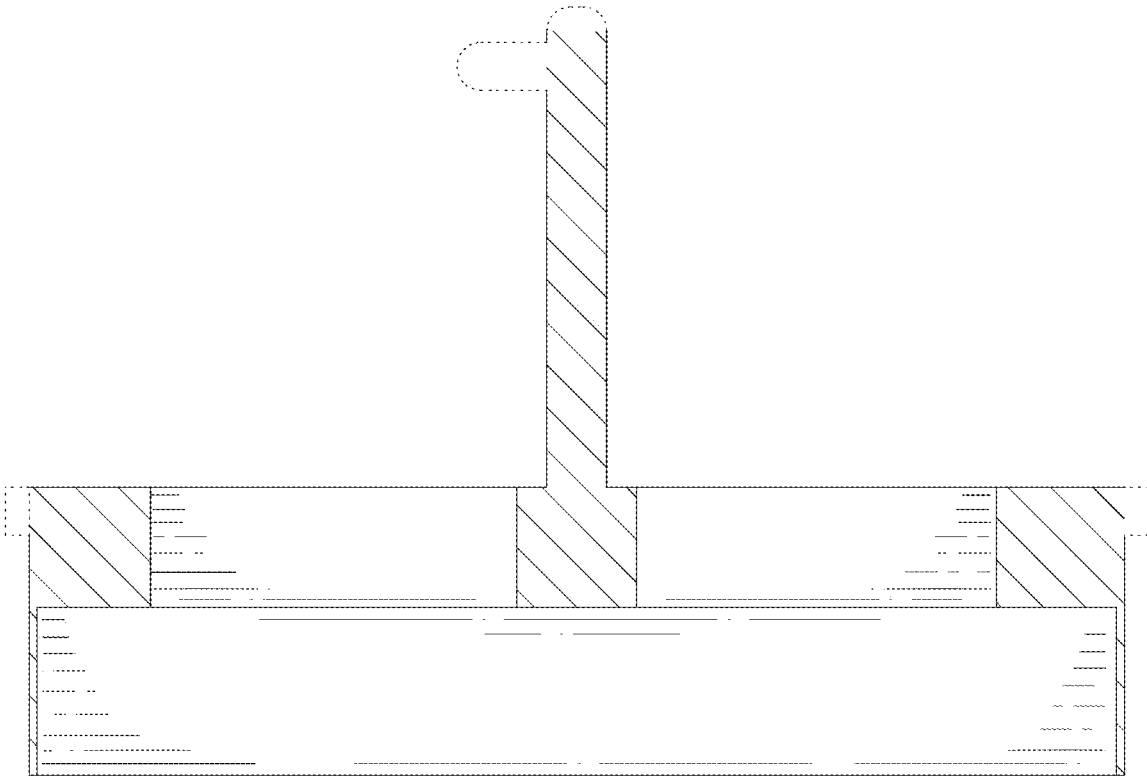

FIG. 7

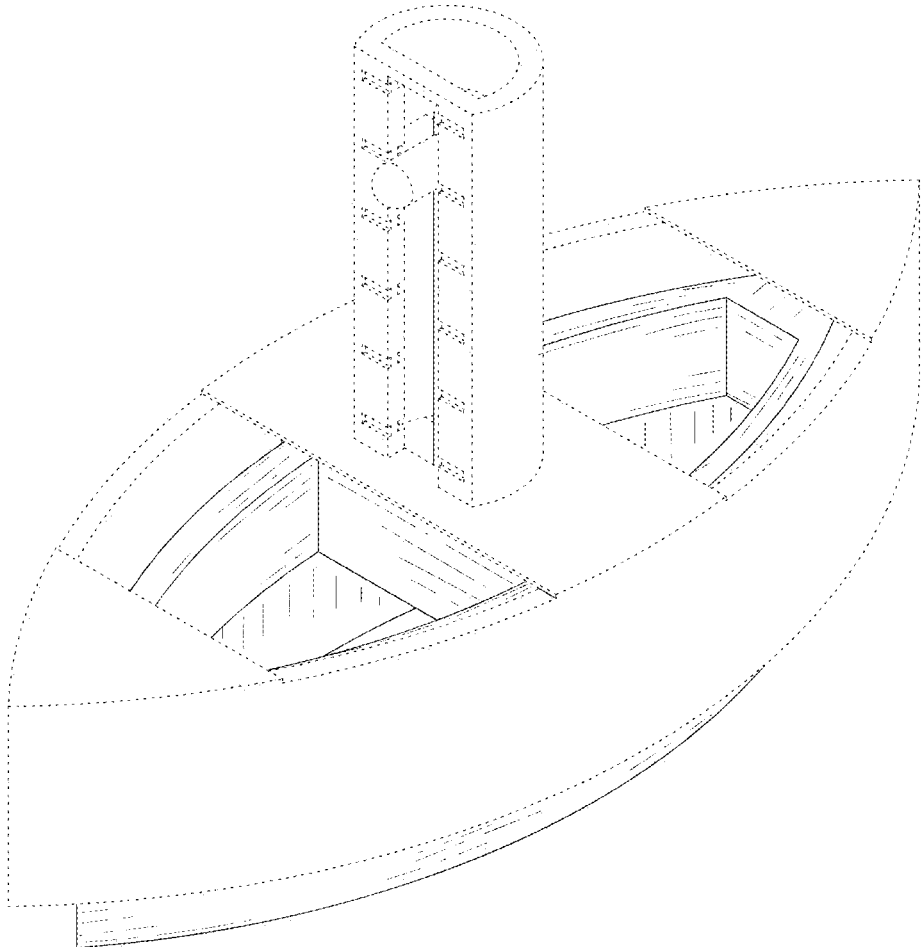

FIG. 8