



(19) **United States**

(12) **Patent Application Publication**  
**Hussell**

(10) **Pub. No.: US 2014/0265809 A1**  
(43) **Pub. Date: Sep. 18, 2014**

(54) **CONNECTOR DEVICES, SYSTEMS, AND RELATED METHODS FOR LIGHT EMITTER COMPONENTS**

(52) **U.S. Cl.**  
CPC ..... *F21V 19/005* (2013.01); *H05K 1/00* (2013.01)  
USPC ..... **313/3**; 174/250; 29/825

(71) Applicant: **CREE, INC.**, Durham, NC (US)

(72) Inventor: **Christopher P. Hussell**, Cary, NC (US)

(21) Appl. No.: **13/839,130**

(22) Filed: **Mar. 15, 2013**

**Publication Classification**

(51) **Int. Cl.**  
*F21V 19/00* (2006.01)  
*H05K 1/00* (2006.01)

(57) **ABSTRACT**

Connector devices and systems for light emitter components and related methods are provided. In some aspects, a connector device includes a body, at least a first trace, and a second trace. In some aspects, connector device can include multiple traces. The first and second traces can be disposed over portions of the body. In some aspects, portions of each of the first and second traces can be electrically and/or physically connectable to each of a first and a second light emitter component via an attachment material.

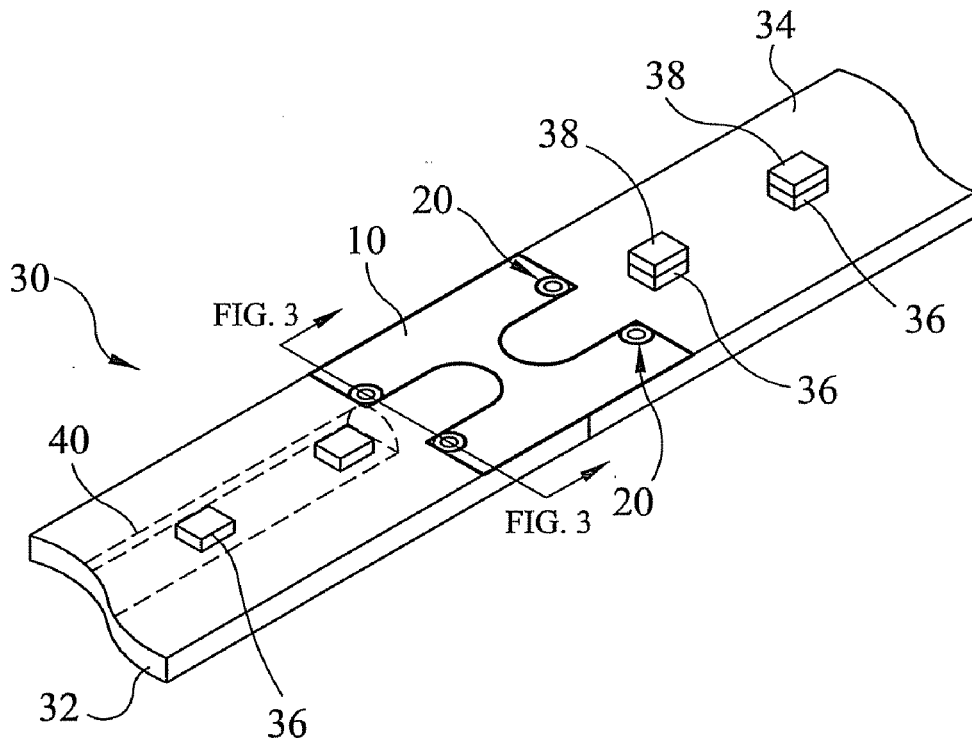

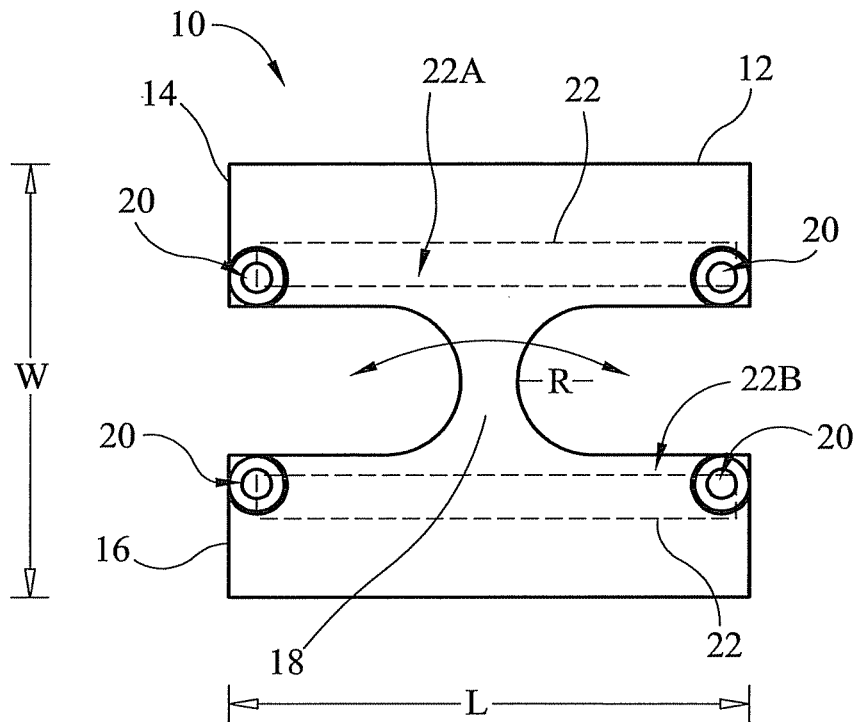

FIG. 1

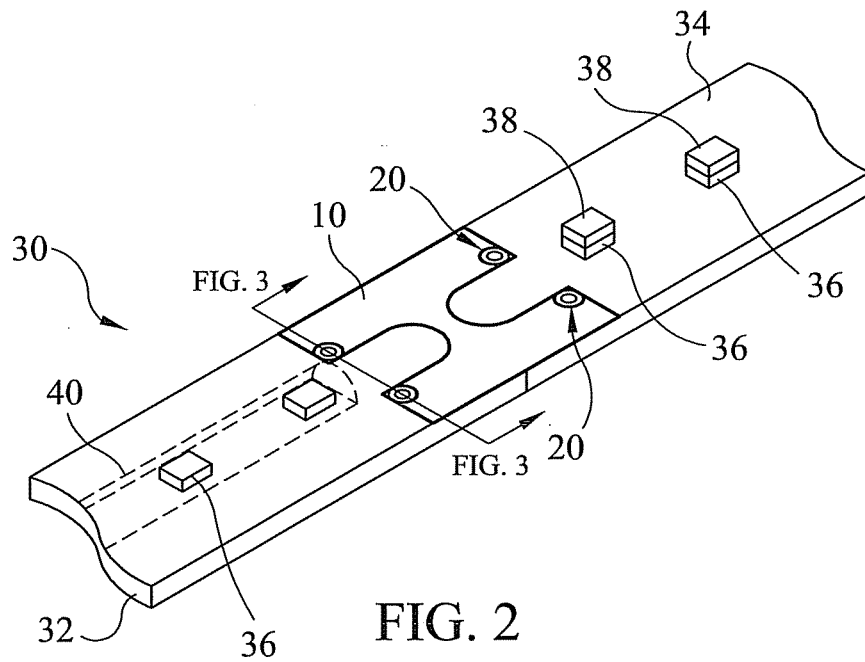

FIG. 2

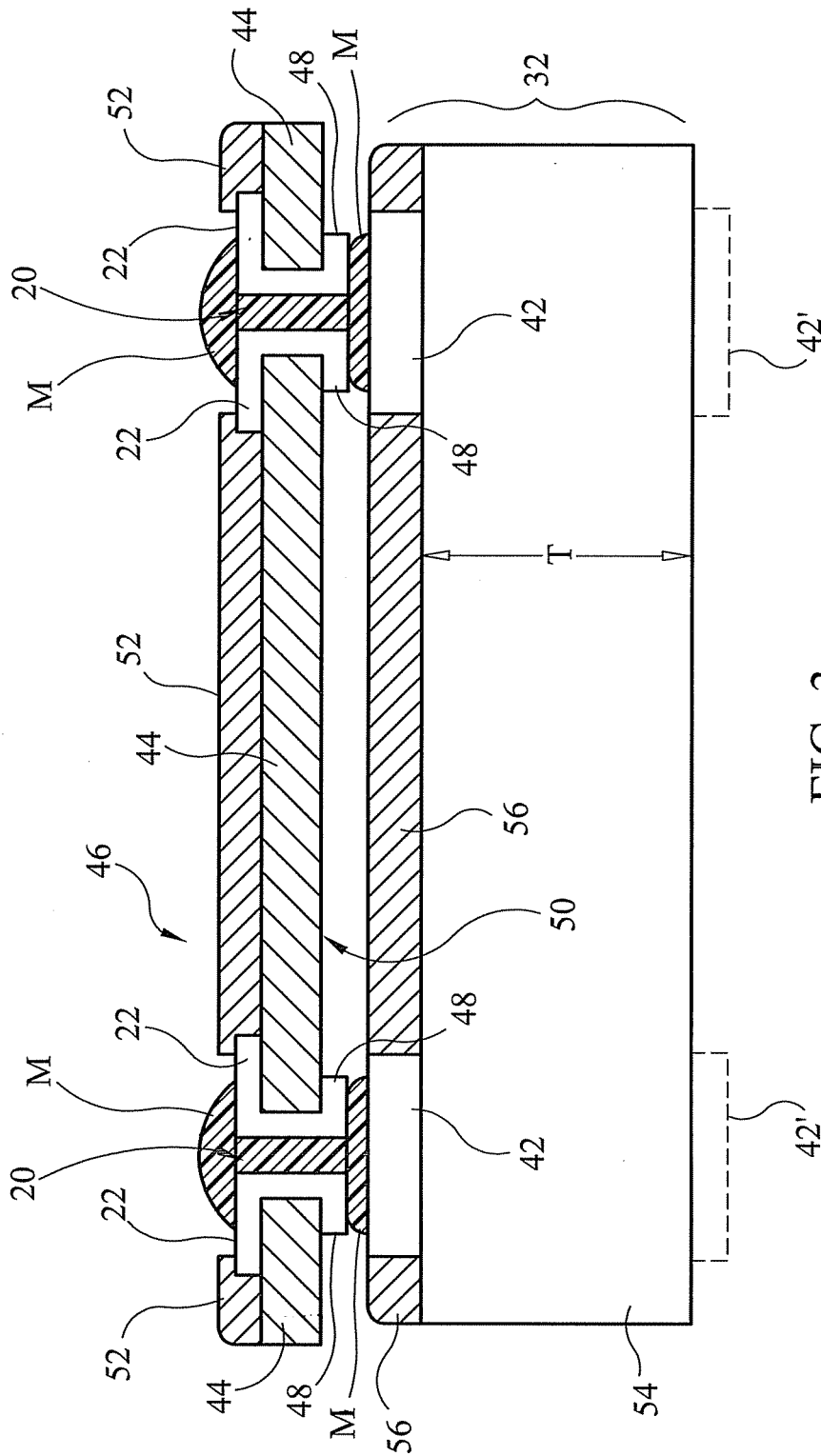

FIG. 3

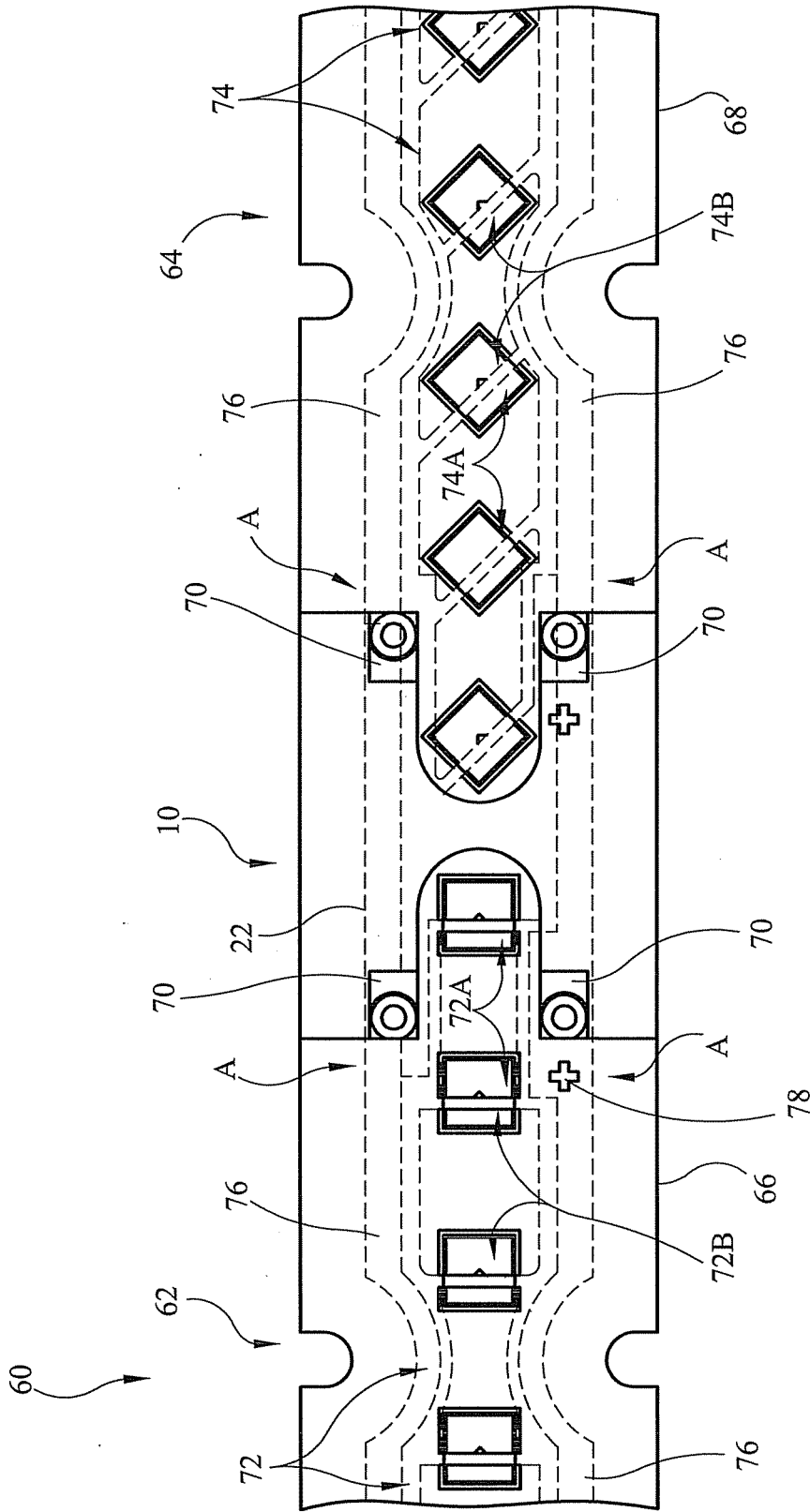

FIG. 4

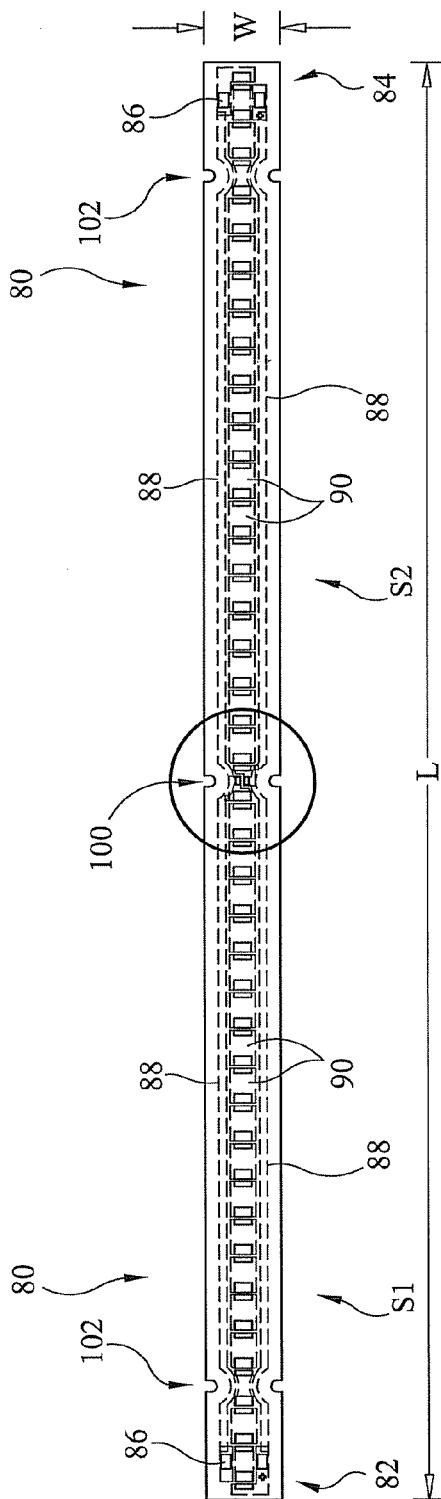

FIG. 5A

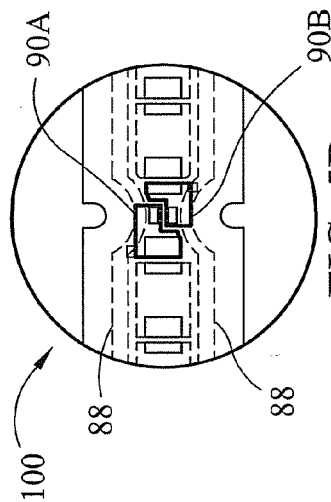

FIG. 5B

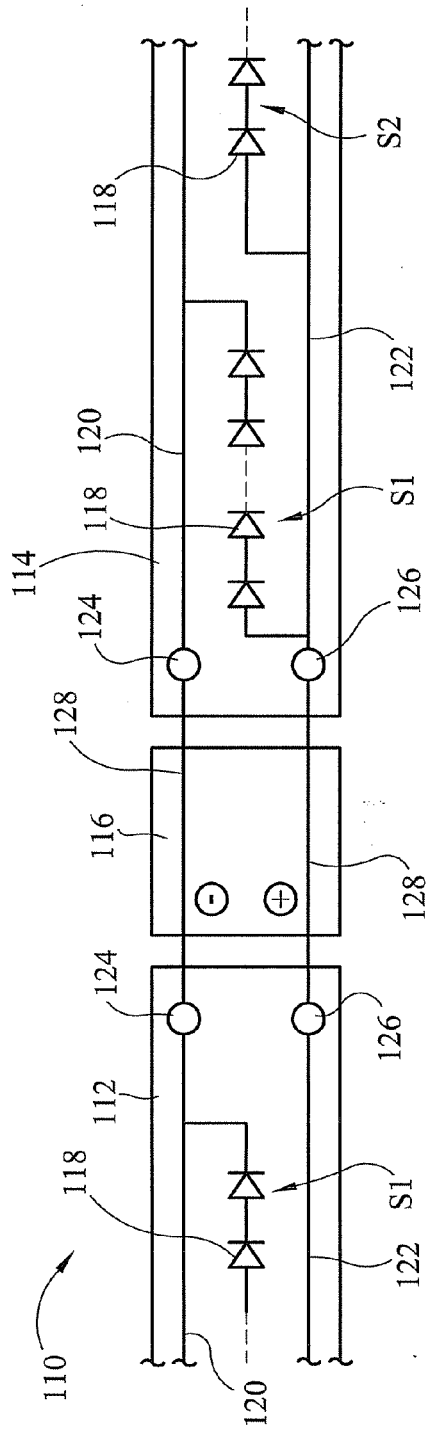

FIG. 6

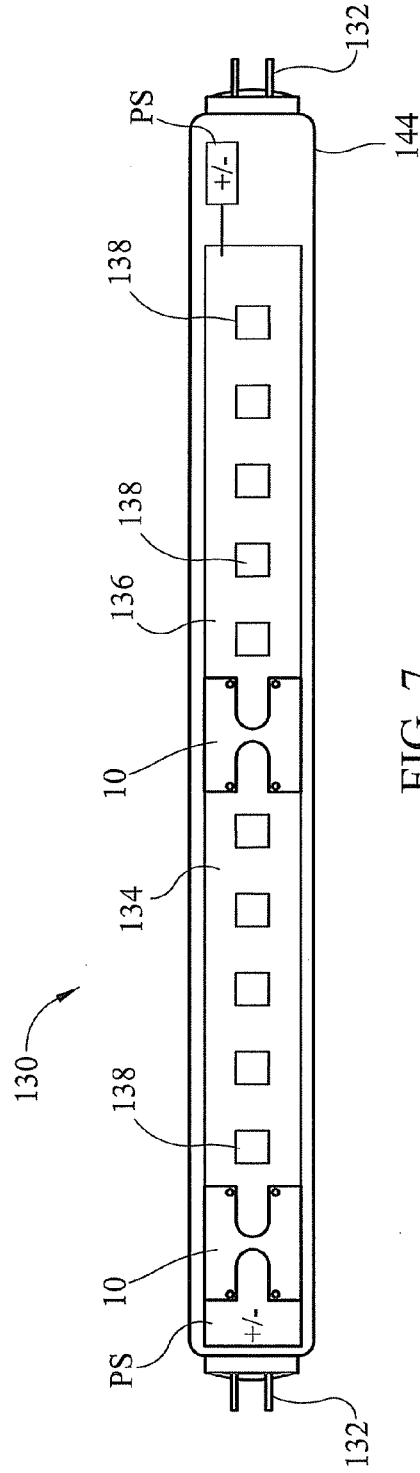

FIG. 7

## CONNECTOR DEVICES, SYSTEMS, AND RELATED METHODS FOR LIGHT EMITTER COMPONENTS

### TECHNICAL FIELD

**[0001]** The subject matter disclosed herein relates generally to connector devices, systems, and methods for use with light emitter components. More particularly, the subject matter disclosed herein relates to physical and/or electrical connector devices and systems for use with light emitting diode (LED) components, and related methods.

### BACKGROUND

**[0002]** Light emitters, such as light emitting diodes (LEDs) or LED chips are solid state devices that convert electrical energy into light. LED chips can be utilized in light emitter components for providing different colors and patterns of light useful in various lighting and optoelectronic applications. For example, light emitter components can be used in various LED light bulb and light fixture applications and used as replacements for incandescent, fluorescent, and metal halide high-intensity discharge (HID) lighting applications.

**[0003]** Currently, one problem associated with conventional substrate based light emitter components which incorporate light emitters, such as LED chips, is that where a lighting system requires multiple components, there is currently not a device or method for electrically coupling or connecting such components other than via soldering multiple thick, bulky electrical wires to each component. Such wires can block, absorb, and/or otherwise interfere with light. Thus, the optical efficiency of the lighting components and/or the lighting system can become compromised. Other connectors that may be available are bulky and add considerable cost to produce devices and systems.

**[0004]** Accordingly, despite the availability of various light emitter components in the marketplace, a need remains for brighter, more cost-effective light emitter components and/or systems which can be efficiently connected via an efficient, cost effect, and/or reflective connector device. Such connector devices and systems can also make it easier for end-users to justify switching to LED products from a return on investment or payback perspective.

### SUMMARY

**[0005]** In accordance with this disclosure, connector devices and systems for light emitter components, and related methods are disclosed herein and have improved performance. For example, connector devices and systems described herein can advantageously provide more efficient electrical and physical connections for light emitter components. Such connector device and systems can also be configured to improve reflection, improve light extraction from emitter components, and/or improve the manufacturability.

**[0006]** These and other objects of the present disclosure as can become apparent from the disclosure herein are achieved, at least in whole or in part, by the subject matter disclosed herein.

### BRIEF DESCRIPTION OF THE DRAWINGS

**[0007]** A full and enabling disclosure of the present subject matter including the best mode thereof to one of ordinary skill

in the art is set forth more particularly in the remainder of the specification, including reference to the accompanying figures, in which:

**[0008]** FIG. 1 is a top plan view illustrating a connector device for light emitter components according to one aspect of the disclosure herein;

**[0009]** FIG. 2 is a top perspective view illustrating a connector system for light emitter components according to one aspect of the disclosure herein;

**[0010]** FIG. 3 is a sectional view illustrating the connector system of FIG. 2;

**[0011]** FIG. 4 is a top plan view illustrating a connector system for light emitter components according to a further aspect of the disclosure herein;

**[0012]** FIGS. 5A and 5B are top plan and detail views illustrating a light emitter component of a connector system according to one aspect of the disclosure herein;

**[0013]** FIG. 6 is a schematic circuit diagram illustrating electrical connectivity within a connector system according to one aspect of the disclosure herein; and

**[0014]** FIG. 7 is a top plan view illustrating a lighting product incorporating connector devices and systems according to one aspect of the disclosure herein.

### DETAILED DESCRIPTION

**[0015]** The subject matter disclosed herein is directed to connector devices, systems, and methods for use with light emitters, such as solid state light emitting devices and light emitting diodes (LEDs) or LED chips. Connector devices, systems, and methods described herein can be adapted to exhibit improved performance, for example, improved efficiency, brightness, light extraction, thermal and/or optical efficiency. In some aspects, each of these improvements contributes to and/or can be provided at a lower cost than conventional components. In some aspects, each of these improvements can be appreciated by using at least one connector device as described herein, where the device is reflective to light, lightweight, and flexible. In some aspects, multiple light emitter components can be electrically and physically connected end-to-end via connector devices described herein.

**[0016]** Reference will be made in detail to possible aspects or embodiments of the subject matter herein, one or more examples of which are shown in the figures. Each example is provided to explain the subject matter and not as a limitation. In fact, features illustrated or described as part of one embodiment can be used in another embodiment to yield still a further embodiment. It is intended that the subject matter disclosed and envisioned herein covers such modifications and variations.

**[0017]** As illustrated in the various figures, some sizes of structures or portions are exaggerated relative to other structures or portions for illustrative purposes and, thus, are provided to illustrate the general structures of the present subject matter. Furthermore, various aspects of the present subject matter are described with reference to a structure or a portion being formed on other structures, portions, or both. As will be appreciated by those of skill in the art, references to a structure being formed "on" or "above" another structure or portion contemplates that additional structure, portion, or both may intervene. References to a structure or a portion being formed "on" another structure or portion without an intervening structure or portion are described herein as being formed "directly on" the structure or portion. Similarly, it will be

understood that when an element is referred to as being “connected”, “attached”, or “coupled” to another element, it can be directly connected, attached, or coupled to the other element, or intervening elements may be present. In contrast, when an element is referred to as being “directly connected”, “directly attached”, or “directly coupled” to another element, no intervening elements are present.

**[0018]** Furthermore, relative terms such as “on”, “above”, “upper”, “top”, “lower”, or “bottom” are used herein to describe one structure’s or portion’s relationship to another structure or portion as illustrated in the figures. It will be understood that relative terms such as “on”, “above”, “upper”, “top”, “lower” or “bottom” are intended to encompass different orientations of the component or component in addition to the orientation depicted in the figures. For example, if the component or component in the figures is turned over, structure or portion described as “above” other structures or portions would now be oriented “below” the other structures or portions. Likewise, if the component or component in the figures are rotated along an axis, structure or portion described as “above”, other structures or portions would be oriented “next to” or “left of” the other structures or portions. Like numbers refer to like elements throughout.

**[0019]** Unless the absence of one or more elements is specifically recited, the terms “comprising”, “including”, and “having” as used herein should be interpreted as open-ended terms that do not preclude the presence of one or more elements.

**[0020]** Light emitter components according to embodiments described herein can comprise group III-V nitride (e.g., gallium nitride (GaN)) based LED chips or lasers. Fabrication of LED chips and lasers is generally known and only briefly described herein. LED chips or lasers can be fabricated on a growth substrate, for example, a silicon carbide (SiC) substrate, such as those devices manufactured and sold by Cree, Inc. of Durham, N.C. Other growth substrates are also contemplated herein, for example and not limited to sapphire, silicon (Si), and GaN. In one aspect, SiC substrates/layers can be 4H polytype silicon carbide substrates/layers. Other SiC candidate polytypes, such as 3C, 6H, and 15R polytypes, however, can be used. Appropriate SiC substrates are available from Cree, Inc., of Durham, N.C., the assignee of the present subject matter, and the methods for producing such substrates are set forth in the scientific literature as well as in a number of commonly assigned U.S. patents, including but not limited to U.S. Pat. No. Re. 34,861, U.S. Pat. No. 4,946,547, and U.S. Pat. No. 5,200,022, the disclosures of which are incorporated by reference herein in their entireties. Any other suitable growth substrates are contemplated herein.

**[0021]** Although various embodiments of LED chips disclosed herein can comprise a growth substrate, it will be understood by those skilled in the art that the crystalline epitaxial growth substrate on which the epitaxial layers comprising an LED chip are grown can be removed, and the freestanding epitaxial layers can be mounted on a substitute carrier substrate or substrate which can have different thermal, electrical, structural and/or optical characteristics than the original substrate. The subject matter described herein is not limited to structures having crystalline epitaxial growth substrates and can be used in connection with structures in which the epitaxial layers have been removed from their original growth substrates and bonded to substitute carrier substrates.

**[0022]** Group III nitride based LED chips according to some embodiments of the present subject matter, for example, can be fabricated on growth substrates (e.g., Si, SiC, or sapphire substrates) to provide horizontal devices (with at least two electrical contacts on a same side of the LED chip) or vertical devices (with electrical contacts on opposing sides of the LED chip). Examples of vertical and horizontal LED chip structures are discussed by way of example in U.S. Publication No. 2008/0258130 to Bergmann et al. and in U.S. Pat. No. 7,791,061 to Edmond et al. which issued on Sep. 7, 2010, the disclosures of which are hereby incorporated by reference herein in their entireties.

**[0023]** One or more solid state light emitters such as LED chips, and notably, portions of components described herein such as portions of the substrate, lens, and/or traces can be at least partially coated with one or more phosphors. The phosphors can absorb a portion of light from the LED chip and emit a different wavelength of light such that the light emitter component emits a combination of light from each of the LED chip and the phosphor. In one embodiment, the light emitter component emits what is perceived as white light resulting from a combination of light emission from the LED chip and the phosphor. In one embodiment according to the present subject matter, a white emitting component can consist of an LED chip that emits light in the blue wavelength spectrum and a phosphor that absorbs some of the blue light and re-emits light in the yellow wavelength spectrum. The component can therefore emit a white light combination of blue and yellow light. In other embodiments, the LED chips emit a non-white light combination of blue and yellow light as described in U.S. Pat. No. 7,213,940. LED chips emitting red light or LED chips covered by a phosphor that absorbs LED light and emits a red light are also contemplated herein.

**[0024]** LED chips can be coated with a phosphor using many different methods, with one suitable method being described in U.S. patent application Ser. Nos. 11/656,759 and 11/899,790, both entitled “Wafer Level Phosphor Coating Method and Devices Fabricated Utilizing Method”, and both of which are incorporated herein by reference in their entireties. Other suitable methods for coating one or more LED chips are described in U.S. Pat. No. 8,058,088 entitled “Phosphor Coating Systems and Methods for Light Emitting Structures and Component Light Emitting Diodes Including Phosphor Coating” which issued on Nov. 15, 2011, and the continuation-in-part application U.S. patent application Ser. No. 12/717,048 entitled “Systems and Methods for Application of Optical Materials to Optical Elements”, the disclosures of which are hereby incorporated by reference herein in their entireties. It is understood that light emitter components and methods according to the present subject matter can also have multiple LED chips of different colors, one or more of which can be white emitting.

**[0025]** FIGS. 1 through 7 are embodiments of connector devices and systems for use with light emitter components, and related methods. Light emitter components can comprise a substrate for supporting light emitters, such as LED chips. Connector devices, systems, and related methods described herein can advantageously be configured for providing more efficient physical and/or electrical connection between light emitter components. Connector devices and systems can also increase reflectivity of light emitter components, which can advantageously improve brightness and light extraction therefrom.



[0026] FIG. 1 illustrates connector device, generally designated 10. As described herein, device 10 can be configured to physically and electrically connect one or more light emitter components to form a connector system. In some aspects, device 10 can comprise a substantially H-shaped body portion 12. However, any shape can be provided. In some aspects, body portion 12 can comprise a first body portion 14, a second body portion 16, and an intermediate body portion 18 disposed therebetween. Notably, device 10 can comprise flexible body and can bend or flex as indicated by the double sided arrow of FIG. 1. In some aspects, one or more portions of device 10 can be pivotal or flexible about intermediate body portion 18.

[0027] In some aspects, device 10 can comprise one or more openings or apertures, generally designated 20. Apertures can be adapted to physically and/or electrically couple device 10 to a light emitter component within a system. In some aspects, apertures 20 can provide an area for solder or other attachment material to settle or flow into when device 10 is physically attached to a component. The attachment material can facilitate physical and/or electrical connection between device 10 and a component (e.g., M, FIG. 3).

[0028] In some aspects, device 10 can be soldered to a light emitter component (FIG. 3). Thus, apertures 20 can provide a conduit for solder and/or other attachment material to flow into and physically connect device 10 to another component upon curing or hardening of the solder. Any attachment method and/or material can be used. For example, one or more pins, rivets, or screws could also be provided at least partially through apertures 20 for physically securing device 10 to another component.

[0029] In some aspects, the inner walls of apertures 20 can be, but do not have to be at least partially plated and/or filled with an electrically conductive coating. That is, in some aspects apertures 20 comprise a through-hole or "via" that can electrically connect an electrically conductive portion of device 10 to another component. Inner walls of apertures 20 can optionally be plated with any suitable electrically conductive material. In some aspects, inner walls of apertures 20 can be plated with one or more thin layers comprising gold (Au), silver (Ag), copper (Cu), nickel (Ni), titanium (Ti), aluminum (Al), tin (Sn), platinum (Pt), palladium (Pd), any alloy thereof, any combination thereof, and/or any other suitable material that is electrically conductive.

[0030] In some aspects, apertures 20 can comprise any size (e.g., diameter), and any shape (e.g., round, non-round). In some aspects, apertures 20 can comprise semi-circular shaped portions disposed proximate opposing outermost ends or edges of body 12. In further aspects, apertures 20 can comprise slots disposed proximate opposing ends of body 12. Any size, shape, configuration, and/or location of apertures 20 can be provided and are contemplated herein. Or in some aspects, attachment areas other than apertures can be provided, which are not required which terminate at an end of device without any hole or slot can be provided.

[0031] Still referring to FIG. 1, in some aspects device 10 can further comprise one or more electrical traces 22 disposed over the body 12 of device. In some aspects, device 10 can comprise at least two electrical traces 22 for electrically connecting a first component to a second component within a connector system (FIG. 2). In some aspects, device 10 can comprise more than two electrical traces 22 (e.g., multiple traces) for physically and electrically connecting multiple devices. Each trace 22 can comprise electrically conductive

material for passing electrical signal or current between components. In some aspects, a first trace 22A can be configured to carry positive electrical signal and a second trace 22B can be configured to carry negative electrical signal, or vice versa. The electrical current or signal can be transferred component-to-component via device 10. Of note, traces 22 are denoted in phantom lines as they can be disposed internally within portions of device 10, and may not be visible from the outside. In some aspects, exterior or exposed traces 22 are contemplated and can be provided. In further aspects, traces 22 can comprise a combination of internal and external or exposed portions within body of device 10.

[0032] In some aspects, traces 22 can extend substantially a full length of the body 12 and/or can extend between portions of apertures 20 at opposing ends of the body. Traces 22 can comprise any suitable electrically conducting material, for example only and not limited to Cu, Au, Ag, Ti, Ni, or any combinations thereof. Traces 22 can be configured to communicate electrical current from a first component to a second component within a system (e.g., FIG. 2).

[0033] Still referring to FIG. 1, device 10 can have any suitable thickness and/or any suitable length or width. In some aspects, device 10 can for example have a thickness of approximately 50  $\mu\text{m}$  or more, approximately 75  $\mu\text{m}$  or more, approximately 100  $\mu\text{m}$  or more, approximately 120  $\mu\text{m}$  or more, or more than 150  $\mu\text{m}$ . Any thickness can be provided.

[0034] Device 10 can for example have a length L of approximately 5 mm or more; approximately 10 mm or more; approximately 15 mm or more, or more than 20 mm. In some aspects, device can have a length of approximately 18 mm. Device 10 can further have a width W of approximately 5 mm or more; approximately 10 mm or more; approximately 15 mm or more; or more than 20 mm. In some aspects, length L can be substantially equal to width W. In other aspects, length L can be different than width W, and optionally a greater or smaller dimension. In some aspects, device 10 can comprise length L and width W of approximately 18 mm $\times$ 15 mm, respectively. In some aspects, body 12 can comprise one or more curved surfaces proximate intermediate body portion 18. The one or more curved surfaces can comprise a radius R of approximately 2.5 mm, or more or less where desired. Other sizes, shapes, and configurations of device 10 can be provided and are contemplated herein.

[0035] FIG. 2 is a perspective view illustrating a connector system, generally designated 30. Connector system 30 can comprise a first light emitter component 32, a second light emitter component 34, and device 10 disposed therebetween. Device 10 can be physically and/or electrically connected to one or more attach surfaces disposed over of first component 32 and to one or more attach surfaces disposed over second component 34. In some aspects, attach surfaces comprise solder pads. In other aspects, attach surfaces can comprise one or more surfaces of a clamp, clip, slot, or aperture configured to attach to one or more apertures 20 or portions of device 10. In some aspects as described in FIGS. 3 and 4, device 10 can be soldered to attach surfaces of each of first and second components 32 and 34, respectively. Notably, device 10 can be adapted to electrically and physically connect to each of first and second devices 32 and 34 via solder or other attachment material (M, FIG. 3). Solder provides an electrical connection between at least one trace (22, FIG. 1) of device 10 and at least one electrically conductive attach surface of each of first and second components 32 and 34, respec-

tively. In some aspects, solder can comprise a physical and electrical point of connection therebetween.

**[0036]** One or more light emitters, such as LED chips **36** can be disposed over each of first and second components **32** and **34**, respectively. Other LED devices other than chips **36**, for example, LED packages can be provided over each of first and second components **32** and **34**. For example, in some aspects LED packages having a submount and optical element or lens can be provided instead of chips **36**. Notably, LED chips **36** can comprise horizontal devices which can directly attach to one or more traces of each of first and second components. This can obviate the need for wirebonded LED chips **36**, which can advantageously obviate the expense and time associated with wirebonding, and can also improve brightness or light extraction as light will not be blocked, absorbed, or otherwise interfered with via wirebonds. In some aspects, each LED chip **36** can comprise two electrical contacts or surfaces (e.g., bond pads) disposed on a bottom surface that can directly attach to traces of first and second components **32** and **34**, respectively. Horizontal light emitters could also be provided, and could be wirebonded to electrical traces of first and second components **32** and **34**. Any structure of LED chip **36** can be provided.

**[0037]** LED chips **36** can be physically and electrically attached to traces of first and second components **32** and **34**, respectively, such as for example via adhesive, solder, epoxy, flux materials, eutectic materials, or via any other suitable attachment material as known in the art. In some aspects, first and second components **32** and **34**, respectively, can comprise a substrate for supporting multiple LED chips **36**. In some aspects, first and second components **32** and **34** can comprise a substrate of FR-4 composite or laminate material having traces provided thereon, a metal core printed circuit board (MCPC), a printed circuit board (PCB), a circuit, a flexible circuit, a ceramic substrate comprising flexible and/or adhesive traces, or a ceramic having electroplated traces. Components **32** and **34** can comprise any suitable substrate which can be capable of supporting one or more LED chips.

**[0038]** In some aspects, a plurality of LED chips **36** can be provided over each component. LED chips **36** can be disposed in a single line or row, an array, or multiple lines or rows. In some aspect, each line or row can comprise at least some serially connected chips extending down a body of each of first and second components **32** and **34**, respectively. In some aspects for example, at least 10 LED chips **36** can be provided over each of first and second components **32** and **34**, respectively. However, more or less than 10 LED chips **36** can be provided and are contemplated herein. LED chips **36** can be arranged in multiple strings of chips and/or LED chips **36** can be arranged in an array or multiple arrays. In some aspects, more than 10 LED chips **36** can be provided per component, in other aspects, more than 15 LED chips **36** can be provided per component **30**, in other aspects, more than 20 LED chips **34** can be provided per component, in some aspects, more than 50 LED chips **36** can be provided per component.

**[0039]** The multiple LED chips **36** provided over each component can comprise a same and/or different colors and/or targeted wavelength range, including for example, being configured to emit light that is primarily red, primarily blue, primarily cyan, primarily green, primarily amber, primarily red-orange, primarily yellow, primarily white, and/or combinations thereof. For example, where multiple LED chips **36** are used per component, LED chips **36** can comprise the

same, similar; and/or, different targeted wavelength bins including red, blue, cyan, green, amber, red-orange, and/or combinations thereof.

**[0040]** LED chips **36** can comprise any suitable dimension, size, structure, and/or shape. For example, square and/or rectangle LED chips **36** having straight cut and/or bevel cut sides are contemplated herein. In one aspect, LED chips **36** can comprise a chip having a length and/or width that is approximately 0.1 mm (e.g., 100  $\mu\text{m}$ ) or more, for example, LED chips **36** can comprise a length and/or width of approximately 0.1 to 0.5 mm; approximately 0.5 to 0.75 mm; approximately 0.75 to 0.85 mm; approximately 0.85 to 0.95 mm; or approximately 1 mm to 2 mm or more. Any sizes and/or shapes of LED chips **36** can be provided and are contemplated herein. In some aspects, first and second light emitter components **32** and **34**, respectively, can comprise a plurality of light emitters that are each an identical size. In other aspects, light emitters of different sizes (large and small) can be used together within each component.

**[0041]** Still referring to FIG. 2 and in some aspects, an optical structure or optical layer **38** can optionally be provided over at least one LED chip **36** of at least one component. In some aspects, LED chips **36** can be disposed directly over components in a chip-on-board (COB) arrangement. In other aspects, LED packages can be provided directly over components described herein. In other aspects, optical layer **38** can be provided over each LED chip **36** in a string of LED chips (e.g., FIG. 6) over each component. In some aspects, optical layer **38** can be disposed over portions of each LED chip providing physical, mechanical, and/or chemical protection thereof. In other aspects, optical layer **36** can also assist in providing a desired color point of light of each component. For example, in some aspects optical layer **38** can comprise a phosphor or lumiphor adapted to absorb some of the light emitted by LED chips **36** and emit light of a different color. In some aspects, light emitted by LED chips **36** and light emitted by optical layer **38** can mix to form a neutral, cool, or white light for use in a lighting fixture. In some aspects, optical layer can comprise a phosphor or lumiphor adapted to emit yellow, red, blue, or green light upon activation by light emitted by LED chips **36**.

**[0042]** In further aspects, other types or configurations of optical layers and/or optical elements can be provided over first and second components **32** and **34**, respectively. For example, optical elements or layers of any size, shape, or material can be provided. In addition to providing color mixing attributes, optical materials can be configured to produce light output of a desired shape, beam pattern, and/or position light in a desired direction (e.g., omnidirectional, unidirectional, etc.), and can comprise a layer of encapsulant, one lens over the string of LED chips **36**, and/or individual lenses over each LED chip **36**.

**[0043]** In some aspects, an optical element **40** can be disposed over a component, where desired, and can comprise a layer of silicone encapsulant dispensed in a bead or row of encapsulant over each LED chip **36** in a given string or strings of LED chips. In some aspects, optical element **40** can comprise any material, such as an epoxy, plastic, glass, and/or silicone material, and can be provided using any method, such as encapsulating or molding. It is understood that optical element **40** can comprise can be at least partially be textured to improve light extraction and/or be coated with or contain

optical conversion, wavelength conversion, light scattering, and/or reflective materials or particles, such as phosphors or light scattering particles.

[0044] In some aspects, at least a portion of optical element 40 can be at least partially concave with respect to the upper surface of each of first and second component 32 and 34, respectively. In some aspects, optical element 40 can be dispensed and then optionally cured upside down to produce the partially concave and/or curved cross-sectional shape. In some aspects, a mold can be used to produce the partially concave and/or curved cross-sectional shape. In some aspects, optical element 40 can comprise a substantially hemispherical, curved, domed, symmetric, or asymmetric shaped cross-section, however, any shape of optical element 40 can be provided. It is further understood that the optical element 40 can be adapted for use with a secondary lens or optics that can be included over optical element 40 by the end user to facilitate beam shaping. These secondary lenses are generally known in the art, with many of them being commercially available. It is further understood that one optical element 40 can be molded or provided over each LED chip 36, where desired.

[0045] In some aspects, where used, wavelength conversion material can be disposed within optical element 40. Wavelength conversion material can comprise one or more binders, phosphors, lumiphors, or a phosphor or lumiphor containing material and/or binder applied via any suitable technique. In one aspect, the wavelength conversion material can absorb at least some of the light emitted from any one of the multiple LED chips 36 and can in turn emit light having a different wavelength such that light emitter component emits a combination of light from one or more LED chips 36 and a phosphor. In some aspects, optical element 40 can be sprayed with phosphor or other wavelength conversion material. In some aspects, optical element 40 can be coated with a phosphor by lamination of a tape cast.

[0046] In one aspect, first and second components 32 and 34, and other light emitter components shown and described herein can emit light that is perceived as white light of approximately 2700 to 7000K, such as cool white (CW) light around 6000K or warm white (WW) light around 3000K. In one aspect, one or more LED chips 36 selected for use can comprise wavelengths targeting CW or WW light upon, for example, mixing with light emitted from the phosphors or a phosphor containing material. Any suitable wavelength bin and/or phosphor combination can be selected depending upon the application and desired light emission. Phosphors can be adapted to emit light that is yellow, green, blue, red, and/or combinations thereof upon absorbing light emitted by one or more LED chips 36. In some aspects, light emitter components shown and described herein such as first and second components 32 and 34, respectively, can be adapted to emit approximately 3500 lumens (lm) at approximately 5000 K and approximately 31 Watts (W). In other aspects, light emitter components shown and described herein can be adapted to emit approximately 2400 lm at approximately 5000K and approximately 18 Watts.

[0047] FIG. 3 illustrates a sectional view of a portion of a portion of first component 32 and device 10 along line 3-3 in FIG. 2. As FIG. 3 illustrates, device 10 can be physically and electrically connected to component 32 via a solder material or other attachment material, generally designated M. Material M can flow into and/or at least partially be disposed within a portion of apertures 20 of device 10. In some aspects,

material M can flow through and/or extend through a portion of apertures 20 and physically and electrically connect device 10 to attachment areas 42 of first component 32.

[0048] Devices and light emitter components described herein can each comprise multiple layers of material. In some aspects, device 10 can comprise a base layer 44 of material. Base layer 44 can comprise any suitable material including, for example, a substantially electrically insulating layer of material, such as a ceramic or dielectric. In some aspects, base layer 44 can comprise a layer of ceramic, glass, FR4 (or FR-4) or related materials, silicon, quartz, plastic, or any other suitable material. In some aspects, FR4 materials can comprise any materials within the accepted international grade designation for fiberglass reinforced epoxy laminates that are flame retardant. In some aspects, base layer 44 can comprise a laminate structure or laminate material.

[0049] In some aspects as discussed with respect to FIG. 1, device 10 can further comprise a layer of electrically conductive material, such as one or more traces 22. In some aspects, trace 22 can extend from apertures 20 disposed at one end of device 10 to apertures 20 extending at a second, opposing end of device 10. By connecting to apertures, multiple components can be physically and electrically coupled via device 10. In some aspects, trace 22 can be disposed on a first side 46 (e.g., a front side) only. In other aspects, device 10 can comprise trace 48 components on a second side 50 as well (e.g., a back side) thereby comprising a two-sided or double-sided connector device 10. Trace 48 on second side 50 can be optional.

[0050] Trace 22 (i.e., and trace 48, where a double-sided device is provided) can comprise any type of electrically conductive material such as a metal or metal alloy. In some aspects, traces 22 and 48 can be adapted to electrically communicate directly with one or more LED components (e.g., first and second components 32 and 34) via solder or other method of physical and/or electrical attachment. At least a portion of traces 22 and 48 can be exposed on a surface of device 10 about apertures 20. In some aspects, traces 22 and 48 can be fully exposed over device 10. Traces 22 and 48 can comprise a layer one or more materials such as, for example, Cu, Ag, Pt, Au, Sn, electroless nickel immersion gold (ENIG), Al, combinations thereof, and/or any other electrically conductive material(s) where desired.

[0051] Still referring to FIG. 3 and in some aspects, an optional non-metallic material 52 can be provided over, about, and/or adjacent portions of each trace 22 and 48, where a double-sided device 10 is provided. In some aspects, non-metallic material 52 can comprise a plastic, thermoplastic, or polymeric material such as a layer of solder mask. In some aspects, non-metallic material 52 can be reflective to light and/or optically reflective. Non-metallic material 52 can comprise a white or silvery white color. Notably, device 10 can be reflective to light, and therefore, have improved properties over existing connecting devices which may block, absorb, or otherwise interfere with light. Device 10 can advantageously improve reflection and, therefore, light extraction per LED component (e.g., first and second components 32 and 34).

[0052] In some aspects, non-metallic material 52 can comprise a liquid curable solder mask material. Non-metallic material 52 can be disposed adjacent portions of traces 22, 48 and apertures 20 and can be disposed over portions of base layer 44. In some aspects, portions of non-metallic material 52 can optionally be covered or layered with an optical con-

version or wavelength conversion material, such as at least one phosphor, lumiphor, and/or more than one phosphoric or lumiphoric material, where desired.

[0053] Still referring to FIG. 3, first component 32 can comprise a substrate having one or more layers of material. In some aspects, first component 32 can comprise a substantially insulating core layer 54 of material, such as a ceramic or dielectric layer of material. Core layer 54 can comprise a layer of ceramic, glass, FR4 (or FR-4), silicon, quartz, plastic, or any other suitable material. In some aspects, core layer 54 can comprise a laminate structure or laminate material. Core layer 54 can comprise any suitable thickness T, for example, approximately 0.1 to 0.5 mm; 0.5 to 1 mm; or more than 1 mm. Any suitable thickness T can be provided.

[0054] In some aspects, component 32 can further comprise an electrically conductive portion or conductive layers of material. In some aspects, conductive layer can comprise one or more traces (FIG. 4) and attachment areas 42. The one or more conductive layers can be provided or disposed over portions of core layer 54 via electroplating techniques, electroless plating techniques, immersion plating techniques, adhesive materials (e.g., such layers can comprise flexible stickers or flexible conductive tape), or any other suitable method of applying metal to a core or base layer. Traces (FIG. 4) and attachment areas 42 can comprise any electrically conductive material or materials such as a metal or metal alloy. In some aspects, attachment areas 42 can be adapted to electrically communicate directly with device 10 via solder or attachment material M. Conductive layers of first component 32, such as traces and/or attachment areas 42 can comprise Cu, Ag, Pt, Au, Sn, electroless nickel immersion gold (ENIG), Al, combinations thereof, and/or any other electrically conductive material(s). Attachment areas 42 and/or traces (FIG. 4) can comprise areas of exposed material, and areas of internally disposed material. Attachment areas 42 and/or traces (FIG. 4) can be at least partially covered with a non-metallic layer of material 56 which can be substantially electrically insulating and reflective to light.

[0055] In some aspects, non-metallic layer of material 56 can comprise a reflective material, such as a solder mask material. Non-metallic layer of material 56 can, for example, comprise a white or silver-white liquid curable material. Non-metallic layer of material 56 can be disposed adjacent portions of attachment areas 42, traces (FIG. 4), and can be disposed over portions of core layer 54. Non-metallic layer of material 56 can further improve the brightness and/or overall optical performance of first component 32 as it can be adapted to reflect light. Portions of non-metallic layer of material 56 and/or attachment areas and traces can optionally be covered or layered with an optical conversion or wavelength conversion material, such as at least one phosphor, lumiphor, and/or more than one phosphoric or lumiphoric material.

[0056] As the broken lines in FIG. 3 illustrate, component 32 can comprise conductive traces or attachment areas 42" on a back side of the component, opposing the side to which device 10 is shown connected. Thus, component 32 can also comprise a double-sided device in some aspects. Attachment areas 42" are indicated in phantom lines, as they are optional. This can be advantageous where a multi-directional and/or omni-directional lighting product is desired. Component 32 could be provided in a lighting fixture or elongated bulb and emit light in more than one direction, as LED chips could be connected to more than one side of component 32.

[0057] Referring now to FIG. 4, a more detailed top plan view of a connector system, generally designated 60, is illustrated. In some aspects, connector system 60 comprise device 10 disposed between a first light emitter component 62 and a second light emitter component 64. First and second light emitter components 62 and 64 can be similar in form, function, and appearance to previously described components 32 and 34, however, LED chips are not shown for convenience and for providing more detail regarding each component.

[0058] Each of first and second components 62 and 64, respectively, can comprise a first and a second panel substrate 66 and 68, respectively, for supporting one or more solid state light emitters, such as one or more LED chips (36, FIG. 2). In some aspects, panel substrates 66 and 68 can comprise a multi-layered substrate comprising a core layer, multiple conductive portions disposed over the core layer, and a reflective non-metallic layer, each of which have been previously described in FIG. 3.

[0059] In some aspects, each panel substrate 66 and 68 can comprise an elongated body adapted for use in strip lighting applications; however, any application and/or any sizes or shapes of substrates 66 and 68 are contemplated and can be provided. In some aspects, multiple LED chips (e.g., 36, FIG. 2) can be supported and provided over portions of each substrate 66 and 68. A plurality, an array, and/or any pattern, design, and/or arrangement of LED chips (not shown) can be provided over each component and respective substrate. LED chips can be arranged in any suitable configuration, such as for example in a substantially straight, linear line configuration, in a diagonal line configuration, in a "checkerboard" arrangement, wherein LED chips alternate above and/or below a substantially straight line, or in a pattern or array. In other aspects, LED chips can be arranged diagonally and/or angled with respect to each other over conductive portions of each substrate 66 and 68. Any configuration or arrangement of LED chips can be provided and is contemplated herein.

[0060] In some aspects, each of first and second components 62 and 64 comprise multiple conductive portions for providing electrical current to LED chips disposed thereon. In some aspects, each of first and second components 62 and 64 comprise attachment areas 70 disposed proximate the ends of components. When connected via device 10, the ends of each of first and second components can substantially abut; however, ends could also be spaced apart. Device can connect to attachment areas 70 via soldering, as previously described. Once physically connected to components via soldering, electrical current can pass from one component, through device 10, and into at least one other component. In some aspects, electrical current can be communicated between multiple devices 10 via traces 22. In some aspects, attachment areas 70 can comprise a solder pad comprising exposed metal, such as exposed Cu, Ag, Pt, Au, tin (Sn), ENIG, Al, combinations thereof, and/or any other electrically conductive material(s). In other aspects, attachment areas 70 can electrically connect with portions of device 10 or with portions of an electrical power source (not shown) for sending current into and out of multiple adjoined light emitter components.

[0061] In some aspects, each of first and second components 62 and 64, respectively, can comprise multiple traces to which multiple LED chips (FIG. 2) can be disposed and/or directly connected. First component 62 can comprise multiple traces, generally designated 72. Second component can comprise multiple traces, such as multiple traces, generally

designated **74**. Each trace **72** and **74** can comprise a pair of traces **72A** and **72B** and **74A** and **74B**. The width of each trace is denoted by the arrows, and each trace **72A**, **72B**, **74A**, and **74B** can comprise internal portions (in phantom lines) and exposed metal portions (solid lines). LED chips are configured to directly attach to exposed portions of traces **72A**, **72B**, **74A**, and **74B**. Each pair of traces can comprise an anode cathode pair for passing electrical current into and out of serially connected LED chips or packages (not shown) attached thereto for causing the illumination thereof. As FIG. 4 illustrates, portions of traces **72** and **74** can be exposed (e.g., in solid lines) on a surface of each component, and other portions of traces **72** and **74** can be internally disposed within a portion of each component, as are indicated in phantom lines.

**[0062]** That is, in some aspects traces **72** and **74** of respective first and second components **62** and **64**, respectively, can comprise an exposed portion designated in solid lines and an internally disposed portion designated in broken lines. The exposed portions can be exposed on an upper (or lower) surface of each respective component. The internally disposed portions are denoted in phantom lines, as they are not visible from outside of the components. Internal portions can be disposed between, for example, a core layer and a non-metallic layer of each component, for example, such as between an FR4 layer and a layer of solder mask as described in FIG. 3. Notably, LED chips (not shown) can be adapted to directly attach to exposed portions of traces **72** and **74** without requiring wirebonds. In some aspects as described further below, LED devices including LED packages (not shown) can be provided over components described herein, and can have back side contacts disposed on a submount or substrate which can be adapted to attach to traces **72** and **74**. In some aspects, LED chips and/or LED devices such as packages can directly attach to traces **72** and **74** via solder, epoxy, flux or eutectic materials, or any other suitable adhesive material.

**[0063]** Notably, electrical current can travel down each component **62** and **64** and into and out of LED chips (not shown) of each of first and second components **62** and **64**, respectively, by passing into and out of pairs of traces, without requiring wirebonds. This can be advantageous, as first and second components **62** and **64** can be more efficient. As FIG. 4 illustrates, traces **72** and **74** can comprise areas over which LED chips (not shown) can be mounted. LED chips can be provided over traces **72** of first component **62** in a substantially linear configuration. LED chips (not shown) can be provided over traces **74** of second component **64** in a substantially angled configuration over substrate **68**, and each chip can be angled with respect to each other. In further aspects as illustrated in FIG. 4, portions of traces **74A** and **74B** can be angled with respect to each other. This can be advantageous as angling light emitters over angled traces **74A** and **74B** can reduce an amount of light blocked by light emitters over substantially linearly arranged, non-angled emitters. Thus, angling emitters and/or respective traces can improve emission from device, and improve luminous intensity provide by respective components.

**[0064]** In some aspects, LED packages, as opposed to chip on board (COB) arrangements of LED chips (e.g., **36**, FIG. 2) can be provided over angled traces **74A** and **74B**. In some aspects, LED packages can comprise a submount or substrate, at least one LED chip disposed over the submount, and an optical element disposed over portions of the LED chip and/or submount. In some aspects, LED packages such as

those disclosed in commonly assigned U.S. patent application Ser. No. 13/649,052, filed on Oct. 10, 2012 can be provided over traces **74A** and **74B**, the disclosure of which is hereby fully incorporated by reference herein. For example, in some aspects LED packages shown in FIGS. 4 and 5 of U.S. application Ser. No. 13/649,052 can be provided over angled traces **74A** and **74B**. Notably, packages can have two bottom contacts adapted to be physically and electrically connected to traces **74A** and **74B**. Such packages can have substantially domed or hemispherical shaped optical elements, or substantially cube shaped optical elements.

**[0065]** In some aspects, each of first and second components **62** and **64**, respectively, can comprise multiple internally disposed bus bars **76**. Bus bars are illustrated in phantom lines, as they may not be visible from the exterior of each of first and second components. In some aspects, bus bars **76** can be adapted to convey electrical current between attachment areas **70** of respective components. That is, bus bars **76** can convey electrical current internally a length of each connector, between respective positive and negative terminals (e.g., positive and negative attachment areas **70** at each end of each component). The electrical polarity of at least one side of each component can be designated by a signal or indicator **78**, such as a "+" or "-" sign. Bus bars **76** can extend between one or more attachment areas **70** of a same polarity for transferring signal to ends of boards (e.g., components), where the ends can be connected to device **10** and/or to a power source (not shown).

**[0066]** Notably, portions of bus bars **76** can be continuous portions of attachment areas **70**, as illustrated by areas A. That is, attachment areas **70** can comprise exposed portions shown in solid lines and can merge with portions of bus bars **76** proximate areas A. Thus, bus bars **76** can physically and electrically communicate with attachment for "bussing" electrical current down sides of each component via bus bars **76** and into and/or between respective attachment areas **70** (e.g., between two areas **70** on the "+" side and two areas **70** the other side). In some aspects, two substantially parallel bus bars **76** can be provided on opposing edges of each component. In some aspects, bus bars **76** can be parallel with a longitudinal axis of component. Each of the parallel bus bars **76** can comprise an opposing electrical polarity, such that together, they form an anode cathode pair communicating signal to respective attachment areas **70** and into strings of LED chips and/or LED devices (e.g., packages).

**[0067]** Referring now to FIG. 5A, a light emitter component, generally designated **80** is illustrated. Component **80** can be similar in form and function to previously described components, however, component **80** can also comprise further novel aspects.

**[0068]** Component **80** can comprise a first end **82** and a second end **84**. One or more exposed attachment areas **86** can be provided at each end. In some aspects, two attachment areas **86** are provided at each end, and each attachment area comprises a different electrical polarity. Thus, a pair of attachment areas **86** at each end can form an anode/cathode pair. Attachment areas **86** can be configured to physically and electrically connect to a power source (not shown) or to portions of a connector device (**10**, FIG. 1) via epoxy, solder, welding, adhesive, or any other suitable materials. As described above with respect to FIG. 4, at least one bus bar **88** can be provided between portions of or more attachment areas **76**. Bus bars **88** can be internally disposed within component **80**, and are illustrated in phantom lines.

[0069] In some aspects, bus bars **88** can be configured to electrically convey or “bus” electrical current from a power source, down a length of each component, and into other components, where desired. In some aspects, two substantially parallel bus bars **88** can be provided per component and can be disposed along opposing edges. In some aspects, bus bars **88** can be substantially parallel to outermost lateral edges of component **80**. In some aspects, traces for one or more strings of LED chips (not shown) can be provided between each substantially parallel bus bar. More than two bus bars **88** can be provided and are contemplated herein.

[0070] In some aspects, multiple traces **90** can be disposed between bus bars **88**. In some aspects, bus bars **88** can be provided proximate outermost edges of component **80**. In some aspects, traces **90** can comprise multiple anode cathode pairs adapted to pass electrical current into and out of LED chips or packages (not shown), which can be directly attached thereto. In some aspects, traces **90** can comprise exposed portions (e.g., illustrated in solid lines) and internal portions disposed between one or more layers of component **80**. The internal portions are illustrated in phantom lines, as they may not be visible from outside component **80**. Together, the internal and external portions of traces **90** comprise a single layer or portion of conductive material. In some aspects, a non-metallic reflector (e.g., a solder mask or plastic material) can be disposed over portions of traces **90**, rendering such portions non-visible from outside of component **80**.

[0071] In some aspects, component **80** can be any suitable size or dimension, for example, any suitable length L and/or any suitable width W. Any suitable thickness can also be provided (e.g., T, FIG. 3). In some aspects for example, component **80** can have a length of approximately 20 millimeters (mm) or more, approximately 100 mm or more, approximately 150 mm or more, approximately 200 mm or more, approximately 250 mm or more, or more than approximately 300 mm in length L. In some aspects, component **80** can have a width W of approximately 5 mm or more, approximately 10 mm or more, approximately 15 mm or more, approximately 20 mm or more, or more than approximately 25 mm. In some aspects, component **80** can have an overall length L and width W of approximately 262.5 mm×15 mm, respectively. Components described herein can have any suitable shape, for example, such as a square shape, a rectangular shape, a non-rectangular shape, a circular shape, a curved shape, a symmetric shape, an asymmetric shape, and/or any other shape. Any size, shape, and/or thickness of components can be provided herein.

[0072] In some aspects, component **80** can comprise a substantially flat upper surface upon which one or more LED chips (not shown) can be linearly disposed along a same planar upper surface of the component substrate. In some aspects, component **80** can be adapted for incorporation into a lighting fixture, bulb, or system, such as a tube light, string light, bi-pin light bulb, or any other directional lighting bulb fixture or system (e.g., FIG. 7). In some aspects, a single component **80** can be used in a fixture or system, in other aspects, multiple, serially or parallel connected components **80** can be used in a fixture or system.

[0073] Still referring to FIG. 5A and notably, one or more of LED chips (not shown) can electrically connect to portions of bus bars at intermediate portions, generally designated **100**. A detailed view of intermediate portion **100** is shown in FIG. 5B. As FIG. 5B illustrates, traces **90** can for example comprise pairs of at least a first trace **90A** and a second trace **90B**.

First and second traces can comprise opposing electrical polarity. In some aspects, as FIG. 5B illustrates, at least one first trace **90A** can physically and/or electrically merge with a portion of one bus bar **88** disposed on one edge of device. The areas where bus bars **88** and traces physically meet are outlined for visibility purposes. In some aspects, the merged can transfer electrical current into and/or terminate electrical current at a first string of LED chips which can be connected in series over as indicated by S1. A second string of LED chips can be connected in series over a second portion of component **80** as indicated by S2. In some aspects, each string can comprise five or more LED chips, 10 or more LED chips, 20 or more LED chips, or more than 20 LED chips. More than two strings (e.g., S1, S2, etc.) of LED chips can be provided per device. In some aspect, each string of LED chips and/or LED packages (not shown) can be electrically connected in series. In other aspects, connecting strings of serially connected LED chips/packages in parallel within component **80** is also contemplated.

[0074] Referring to FIGS. 5A and 5B, one or more attachment regions **102** can be provided along edges of component **80**. In some aspects, attachment members (e.g., screws, bolts, rivets, pins, nails, clips, hooks, etc.) can be configured to become at least partially secured within regions **102** thereby affixing component **80** to a portion of a lighting fixture or device.

[0075] FIG. 6 is a schematic circuit diagram illustrating electrical connectivity of components within a connector system, generally designated **110**. System **110** can comprise a first component **112**, a second component **114**, and a connector device **116** disposed therebetween. As FIG. 6 illustrates, multiple LED devices **118** can be provided and electrically connected in series over each of first and second components **112** and **114**, respectively. LED devices **118** can comprise COB LED chips and/or packaged LED chips. Each component can comprise a first bus bar **120** and a second bus bar **122** of opposing electrical polarity. Bus bars **120** and **122** can convey electrical current between first and second attachment area **124** and **126** of each connector, which also have opposing electrical polarity.

[0076] As FIG. 6 illustrates, connector device **116** can convey electrical current between attachment surfaces **124** and **126** of a same electrical polarity via parallel traces **128** of opposing electrical polarity. As FIG. 6 further illustrates, each component **112** and **114** can comprise multiple strings of LED chips **118** which can terminate between bus bars **120** and **122**. As FIG. 6 illustrates, components can comprise a plurality of strings of LED devices **118**, designated S1 and S2. In some aspects, each string S1 and S2 of LED devices **118** can be connected in parallel between opposing bus bars. In some aspects, each component comprises only a single string S1 of serially connected LED devices **118**. In other aspects, each component comprises more than one and/or more than two strings of LED chips. In some aspects, serially connected strings S1, S2, . . . SN are contemplated.

[0077] FIG. 7 illustrates a light emitter component system comprising a lighting fixture, including but not limited to a bulb (e.g., the T8 fluorescent format) which can be used in overhead lighting. Multiple types of lighting fixtures, bulbs, and/or products can be provided and are contemplated herein. FIG. 7 illustrates another embodiment of a connector system generally designated **130**. Connector system **130** can comprise more than one light emitter component, such as first and second components **134** and **136**. One or more strings of LED

devices **138** (e.g., chips or LED packages) can be provided over each component. Notably, LED devices **138** can directly attach to portions of exposed metal (e.g., exposed portions of traces) disposed on each component, obviating the need for wirebonding the chips. Each elongated component can be disposed end-to-end and connected via a connector device **10**, as previously described. More than two components can be attached end-to-end, or only one component can be used within the fixture, depending upon the size requirements.

**[0078]** Light emitter components **134** and **136** may not be visible from outside of system **130**, in some aspects, a system housing **144** can obstruct the view, however, such components are shown herein for illustration purposes. In some aspects, light emitter components **134** and **136** can be physically and/or electrically coupled as via device **10**. In some aspects, connector system **130** can be disposed within a bulb for use in strip lighting, tube lighting and/or overhead lighting products. System **130** can comprise two pins **132** disposed at each end. Electrical current can pass into system **130** via pins **132**. In some aspects, light emitter components **134** and **136** can receive current by coupling the ends to a positive or negative terminal of a power source PS. In some aspects, power source PS can receive power from pins **132**. Notably, as FIG. 7 illustrates, connector devices **10** can also be provided between outermost portions of at least one component (e.g., **134**) and wherein the component connects to power source PS. In some aspects, emitter components **134** and **136** can be contained within a system or bulb housing **144**. In some aspects, housing **144** can comprise a tube diffuser. For illustration purposes, system **130** is shown as an elongated bulb used in lighting products, however, any other system, bulb, or lighting fixture can be provided.

**[0079]** As described above, novel connector devices and light emitter components can be provided alone and/or in combination for providing components and systems having improved optical performance at a lower cost. Embodiments as disclosed herein may provide one or more of the following beneficial technical effects: improved brightness; improved light extraction; improved efficiency; reduced manufacturing cost of light emitter components and/or systems; improved thermal management (and concomitant improvement of operating life); and/or improved manufacturability of light emitter components.

**[0080]** While the subject matter herein has been described in reference to specific aspects, features, and/or illustrative embodiments, it will be appreciated that the utility of the described subject matter is not thus limited, but rather extends to and encompasses numerous other variations, modifications and alternative embodiments, as will suggest themselves to those of ordinary skill in the field of the present subject matter, based on the disclosure herein. Various combinations and sub-combinations of the structures and features described herein are contemplated and will be apparent to a skilled person having knowledge of this disclosure. Any of the various features and elements as disclosed herein may be combined with one or more other disclosed features and elements unless indicated to the contrary herein. Correspondingly, the subject matter as hereinafter claimed is intended to be broadly construed and interpreted, as including all such variations, modifications and alternative embodiments, within its scope and including equivalents of the claims.

What is claimed is:

1. A connector device for light emitter components, the device comprising:
  - a body;
  - at least a first trace and a second trace disposed over portions of the body; and
  - wherein portions of each of the first and second traces are electrically and physically connectable to each of first and second light emitter components via an attachment material.
2. The device of claim 1, wherein the body is flexible.
3. The device of claim 1, wherein the body is approximately 100  $\mu\text{m}$  or more in thickness.
4. The device of claim 1, wherein the body is substantially H-shaped.
5. The device of claim 1, wherein the body reflects light.
6. The device of claim 1, wherein the body is white.
7. The device of claim 1, wherein the body is coated with a wavelength conversion material.
8. The device of claim 7, wherein the wavelength conversion material comprises a phosphor.
9. The device of claim 1, wherein the body comprises multiple layers of material.
10. The device of claim 1, wherein the body comprises a dielectric layer of material, a conductive layer of material, and a non-metallic reflective layer of material.
11. The device of claim 10, wherein the dielectric layer of material comprises FR-4 or related materials.
12. The device of claim 1, further comprising multiple traces.
13. The device of claim 1, wherein the attachment material comprises solder.
14. A connector system for light emitter components, the connector system comprising:
  - a first light emitter component comprising one or more strings of light emitting diode (LED) devices;
  - a second light emitter component comprising one or more strings of LED devices; and
  - a connector device disposed between the first and second light emitter components, the connector device being physically and electrically connected to each of the first and second light emitter components, and wherein the connector device comprises a dielectric layer of material, a conductive layer of material.
15. The system of claim 14, wherein the connector device further comprises a non-metallic reflective layer of material.
16. The system of claim 14, wherein the first light emitter component comprises two strings of connected LED devices.
17. The system of claim 14, wherein each string of serially connected LED chips is connected in parallel.
18. The system of claim 14, wherein the first light emitter component comprises an elongated substrate.
19. The system of claim 18, wherein first and second opposing bus bars are internally disposed within the elongated body.
20. The system of claim 14, wherein the connector device is flexible.
21. The system of claim 14, wherein the connector device is approximately 100  $\mu\text{m}$  or more in thickness.
22. The system of claim 14, wherein the connector device is substantially H-shaped.
23. The system of claim 14, wherein the connector device reflects light.

**24.** The system of claim **14**, wherein the connector device is coated with wavelength conversion material.

**25.** A light bulb comprising the system of claim **14**.

**26.** The system of claim **14**, wherein the dielectric layer of material comprises FR-4 or related materials.

**27.** A method of connecting light emitter components, the method comprising:

providing a first light emitter component end-to-end and abutting a second light emitter component;

providing a connector device between ends of the first light emitter component and the second light emitter component;

electrically connecting the connector device to each of the first and second light emitter components such that electrical current is conveyed from the first component through the connector device and into the second component.

**28.** The method of claim **27**, wherein providing a first light emitter component comprises providing a plurality of light emitting diode (LED) devices serially connected over a multi-layered substrate.

**29.** The method of claim **27**, wherein providing the connector device comprises providing a reflective connector device.

**30.** The method of claim **27**, further comprising connecting the multiple strings of LED devices in parallel over the first light emitter component.

**31.** The method of claim **30**, further comprising connecting the multiple strings of LED chips in parallel over the second light emitter component.

**32.** The method of claim **27**, wherein providing the connector device comprises providing a multi-layered connector device.

**33.** The method of claim **32**, wherein providing the multi-layered connector device comprises providing a dielectric layer of material, providing a conductive layer of material over the dielectric layer of material, and providing a non-metallic reflective layer of material over the conductive layer of material.

**34.** The method of claim **33**, wherein the dielectric layer of material comprises FR-4 or related materials.

**35.** The method of claim **27**, a substantially H-shaped connector device is provided.

**36.** The method of claim **27**, further comprising placing the connector device and each of the first and second light emitter components within a bulb.

\* \* \* \* \*