



- (51) **International Patent Classification:**  
*G07C 9/00* (2006.01)      *G08B 25/14* (2006.01)  
*G06K 19/07* (2006.01)
- (21) **International Application Number:**  
PCT/US2017/039719
- (22) **International Filing Date:**  
28 June 2017 (28.06.2017)
- (25) **Filing Language:** English
- (26) **Publication Language:** English
- (30) **Priority Data:**  
62/356,209      29 June 2016 (29.06.2016)      US  
15/626,617      19 June 2017 (19.06.2017)      US
- (71) **Applicant: SPECTRUM BRANDS, INC.** [US/US]; 3001 Deming Way, Middleton, Wisconsin 53562 (US).
- (72) **Inventor: BROWN, Troy M.**; 197 Woodcrest Lane, Aliso Viejo, California 92656 (US).
- (74) **Agent: BRUESS, Steven C.**; Merchant & Gould P C., P.O. Box 2903, Minneapolis, Minnesota 55402-0903 (US).
- (81) **Designated States** (*unless otherwise indicated, for every kind of national protection available*): AE, AG, AL, AM, AO, AT, AU, AZ, BA, BB, BG, BH, BN, BR, BW, BY, BZ, CA, CH, CL, CN, CO, CR, CU, CZ, DE, DJ, DK, DM, DO, DZ, EC, EE, EG, ES, FI, GB, GD, GE, GH, GM, GT, HN, HR, HU, ID, IL, IN, IR, IS, JO, JP, KE, KG, KH, KN, KP, KR, KW, KZ, LA, LC, LK, LR, LS, LU, LY, MA, MD, ME, MG, MK, MN, MW, MX, MY, MZ, NA, NG, NI, NO, NZ, OM, PA, PE, PG, PH, PL, PT, QA, RO, RS, RU, RW, SA, SC, SD, SE, SG, SK, SL, SM, ST, SV, SY, TH, TJ, TM, TN, TR, TT, TZ, UA, UG, US, UZ, VC, VN, ZA, ZM, ZW.
- (84) **Designated States** (*unless otherwise indicated, for every kind of regional protection available*): ARIPO (BW, GH, GM, KE, LR, LS, MW, MZ, NA, RW, SD, SL, ST, SZ, TZ, UG, ZM, ZW), Eurasian (AM, AZ, BY, KG, KZ, RU, TJ, TM), European (AL, AT, BE, BG, CH, CY, CZ, DE, DK, EE, ES, FI, FR, GB, GR, HR, HU, IE, IS, IT, LT, LU, LV, MC, MK, MT, NL, NO, PL, PT, RO, RS, SE, SI, SK, SM,

(54) **Title:** PASSIVE RFID DOOR LOCK

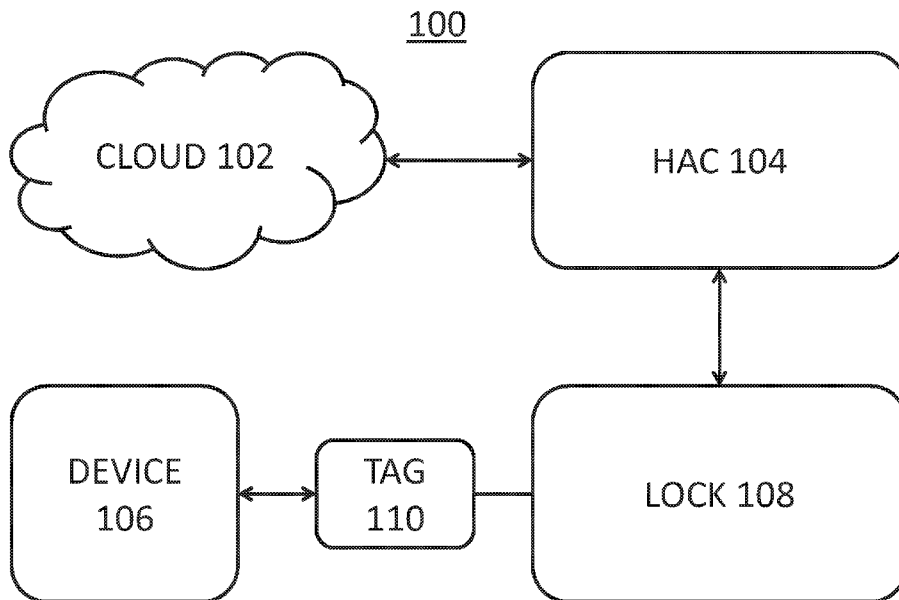

FIGURE 1

(57) **Abstract:** An electronic or non-electronic lockset with a passive RFID tag operating methods and system is described herein. The passive RFID tag is affixed to or near the lockset. Using an application on a mobile device, a user can leverage the mobile device to enable features such as user notifications, home automation control, and home security control. A visitor to a home uses an application on their mobile device to scan the passive RFID to gain entry to a home through verification by a remote homeowner.



TR), OAPI (BF, BJ, CF, CG, CI, CM, GA, GN, GQ, GW,  
KM, ML, MR, NE, SN, TD, TG).

**Declarations under Rule 4.17:**

- *as to applicant's entitlement to apply for and be granted a patent (Rule 4.17(ii))*

**Published:**

- *with international search report (Art. 21(3))*

## PASSIVE RFID DOOR LOCK

Related Applications

[0001] This application claims the benefit of U.S. Provisional Application Serial No. 62/356,209 filed June 29, 2016 for a “Passive RFID Door Lock,” which is hereby incorporated by reference in its entirety.

Technical Field

[0002] The present disclosure relates generally to locking devices; in particular, this disclosure relates to an electronic locking device operable with an affixed passive RFID tag.

Background and Summary

[0003] Locking and security systems are in widespread use in residential and commercial markets. Locking and security systems control ingress through doors to secured areas, such as a building or other secured space, by requiring certain authorized credentials. Existing security systems may include electronic locks which may control mechanical locking assemblies, such as movement of a deadbolt between its extended and retracted positions. Existing security systems that include radio-frequency identification (“RFID”) solutions in the form of RFID tag readers do not incorporate passive RFID tag solutions.

[0004] According to one aspect, this disclosure provides a system comprising a lockset for use with a mobile device. The system comprises a locking device, a passive radio frequency identification (“RFID”) tag and a mobile device. The locking device is movable between a locked position and an unlocked position. The passive RFID tag is affixed to a housing of the locking device. The mobile device comprises a reader and is configured to: scan the passive RFID tag, automatically transmit one or more notifications, and update a cloud service.

[0005] According to another aspect, this disclosure provides a system with a locking device, a passive radio frequency identification (“RFID”) tag, and a mobile device. The locking device is movable between a locked position and an unlocked position. The passive RFID tag is affixed to a housing of the locking device. The mobile device comprises a reader and is configured to: scan the passive RFID tag and issue one or more commands to a home automation controller.

#### Brief Description of the Drawings

[0006] The detailed description makes reference to the accompanying figures in which:

[0007] Figure 1 is a simplified block diagram of an example system for operating the lock hardware according to an embodiment of this disclosure;

[0008] Figure 2 is a side view of an electronic lock and corresponding hardware in accordance with an embodiment of the present disclosure, installed on a door and with the door shown in phantom lines;

[0009] Figure 3 is a flow diagram of an exemplary method of at least one embodiment of the disclosure;

[00010] Figure 4 is a flow diagram of an exemplary method of at least one embodiment of the disclosure;

[00011] Figure 5 is a flow diagram of an exemplary method of at least one embodiment of the disclosure; and

[00012] Figure 6 is a simplified block diagram of an exemplary computing environment in connection with at least one embodiment of the lock assembly of Figure 1.

Detailed Description of the Drawings

[00013] The figures and descriptions provided herein may have been simplified to illustrate aspects that are relevant for a clear understanding of the herein described devices, systems, and methods, while eliminating, for the purpose of clarity, other aspects that may be found in typical devices, systems, and methods. Those of ordinary skill may recognize that other elements and/or operations may be desirable and/or necessary to implement the devices, systems, and methods described herein. Because such elements and operations are well known in the art, and because they do not facilitate a better understanding of the present disclosure, a discussion of such elements and operations may not be provided herein. However, the present disclosure is deemed to inherently include all such elements, variations, and modifications to the described aspects that would be known to those of ordinary skill in the art.

[00014] References in the specification to “one embodiment,” “an embodiment,” “an illustrative embodiment,” etc., indicate that the embodiment described may include a particular feature, structure, or characteristic, but every embodiment may or may not necessarily include that particular feature, structure, or characteristic. Moreover, such phrases are not necessarily referring to the same embodiment. Further, when a particular feature, structure, or characteristic is described in connection with an embodiment, it is submitted that it is within the knowledge of one skilled in the art to affect such feature, structure, or characteristic in connection with other embodiments whether or not explicitly described. Additionally, it should be appreciated that items included in a list in the form of “at least one A, B, and C” can mean (A); (B); (C); (A and B); (A and C); (B and C); or (A, B, and C). Similarly, items listed in the form of “at least one of A, B, or C” can mean (A); (B); (C); (A and B); (A and C); (B and C); or (A, B, and C).

[00015] In the drawings, some structural or method features may be shown in specific arrangements and/or orderings. However, it should be appreciated that such specific arrangements and/or orderings may not be required. Rather, in some embodiments, such features may be arranged in a different manner and/or order than shown in the illustrative figures. Additionally, the inclusion of a structural or method feature in a particular figure is not meant to imply that such feature is required in all embodiments and, in some embodiments, may not be included or may be combined with other features.

[00016] In some embodiments, this disclosure relates to a door lock, either electric or non-electronic, that incorporates a passive RFID tag. The door lock offers RFID benefits without the use of an incorporated RFID tag reader. For example, the passive RFID tag can leverage a user's mobile device, such as a smart phone, a configurable application ("app"), and the Internet (or "cloud"). The passive RFID tag can be in sticker form, printed circuit board ("PCB") form, or other configurations. Embodiments are contemplated in which the computing processing power of a user's device may be leveraged to enable features that would otherwise not be available without more advanced wireless electronics incorporated into the door lock. The term "door lock" is broadly intended to be construed as encompassing any hardware associated with a door, including but not limited to a lock, a door lever, a door knob, a hinge, etc. In some embodiments, the passive RFID tag could be installed on a door separate from the door lock, such as in a nearby position.

[00017] Figure 1 shows an example system configuration 100 for at least one exemplary embodiment. In the example shown, the system includes a cloud server 102, a Home Automation Controller (HAC) 104, a user device 106, a tag 110, and a lock 108. The cloud server 102 may further comprise or be a part of a network, such as a local area network, wide area network, the Internet, or the like. The HAC 104 may be a home security system or automation system connected (wired or wirelessly) to other devices in around the dwelling

associated with the lock 108. The HAC 108 may control the lock 108, and/or other devices (not shown). These devices may include, but are not limited to, lights, entertainment devices, or kitchen appliances, etc. The user device 106 may be a portable user device, such as a smartphone, cell phone, tablet computer, or the like.

[00018] Figure 2 shows an exemplary lock 200, either electronic or non-electronic, mounted to a door 202. In the example shown, the lock 200 includes an interior assembly 204 with a battery holder 206, a turn-piece 208, a bolt 210, a strike 212, a user input 214, an exterior assembly 216, a mechanical locking assembly 218, and a key 220. The exterior assembly 216 may further comprise a passive RFID tag in sticker form, or the like. In some cases, credentials and/or commands may be provided wirelessly to the lock 200, such as disclosed in U.S. Pre-grant Pub. No. 2014/0250956 for an “Electronic Deadbolt” filed February 25, 2014 and U.S. Patent No. 9,024,759 for a “Wireless Lockset With Integrated Antenna, Touch Activation, and Light Communication Method,” filed Mar. 10, 2014, which are hereby incorporated by reference.

[00019] Figure 3 is a simplified flowchart showing an example notification process of use of the door using the software application on the user device 106. A user of the device may initiate the process via the software application. In this example, the method 300 begins with Block 302, in which a user scans the passive RFID tag affixed or in close proximity to the door lock. At Decision Block 304, the software application determines if the tag is recognized. If “NO,” the process ends. If “YES,” the method moves to Block 306 and notifications are sent automatically. Notifications sent include, but are not limited to, SMS text messages, e-mail, or the like. Notifications may also include social network status updates, such as a “tweet” on Twitter® or a status update on Facebook®. The update may be, for example, a status update of “Finally home!” or the like. Notifications to be sent may be pre-configured by the device user via the software application, or the like. The process

then moves to Block 308 and a cloud service (i.e., Cloud 102 of Figure 1) may be notified of the lock tag scan. A cloud service may be configured to track locks scanned along with other information, such as time scanned, audit trail information update, etc. Even further, the cloud service may trigger and/or issue other commands, such as a command to a home automation controller (i.e. HAC 104 of Figure 1). The door use notification process is then considered complete and the process ends.

[00020] Figure 4 is a simplified flowchart showing an example home automation trigger process based on use of the door using the software application on the user device 106. A user of the device may initiate the process via the software application. In this example, the method 400 begins with Block 402, in which a user scans the passive RFID tag affixed or in close proximity to the door lock. At Decision Block 404, the software application determines if the tag is recognized. If “NO,” the process ends. If “YES,” the method moves to Block 406 and commands are launched, issued, or triggered. Commands may be issued via the user device or cloud service 102 to home automation controller (i.e., HAC 104 of Figure 1). Commands issued could include, but are not limited to, disable burglar alarm, set Home Automation Scene to “Evening,” and/or turn on or activate an appliance in the dwelling, such as a coffee maker to brew a pot of coffee. These non-limiting examples are considered exemplary of a myriad of different commands that may be issued to a Home Automation Controller, as is known to one of ordinary skill in the art based on differing capabilities of Home Automation Controllers in use today and beyond. The home automation trigger process is then considered complete and the process ends.

[00021] Figure 5 is a simplified flowchart showing an example home automation door unlock process based on use of the door by a visitor using the software application on the user device 106. A user of the device may initiate the process via the software application. In this example, the method 500 begins with Block 502, in which a user scans the passive



RFID tag affixed or in close proximity to the door lock. At Block 504, a command is issued by the software application to a cloud service. At Decision Block 506, the cloud service determines whether a homeowner's account is linked to the RFID tag that was scanned. If "NO," the process ends. If "YES," the process moves to Block 508 and a message is sent to the homeowner. The message indicates that a visitor is present at the door. The message may be sent via text message, email, or the like. The message may include identifying information of the visitor and the homeowner issues verification information. At Decision Block 510, if a user does not verify the visitor, access is not granted, or do not unlock door, then "NO" and the process ends. If the user does verify and therefore "YES" to Decision Block 510, the process moves to Block 512 and the door is unlocked via the home automation controller 104. The homeowner may send verification via return message, such as via text message, email, or the like. The unlock message may be sent via the cloud service 102 and may include further commands, such as disable burglar alarm, or the like. At Block 514, the visitor may scan the lock tag upon leaving the premises. At Block 516, commands may be triggered via the software application. The commands include, but are not limited to, re-lock the door, re-arm the alarm system and/or transmit a verification message to the homeowner. The home automation door unlock process is then considered complete and the process ends.

[00022] Referring now to Figure 6, a simplified block diagram of an exemplary computing environment 600 for the device 106, in which the door lockset application is realized, is shown. The illustrative implementation 600 includes a device 106, which may be in communication with one or more other computing systems or devices 626 via one or more networks 102. As shown, the device 106 comprises storage media 610.

[00023] The illustrative device 106 includes at least one processor 602 (e.g. a microprocessor, microcontroller, digital signal processor, etc.), memory 604, and an

input/output (I/O) subsystem 606. Although not specifically shown, it should be understood that the I/O subsystem 606 may include, among other things, an I/O controller, a memory controller, and one or more I/O ports. The processor 602 and the I/O subsystem 606 are communicatively coupled to the memory 604. The memory 604 may be embodied as any type of suitable computer memory device (e.g., volatile memory such as various forms of random access memory).

[00024] The I/O subsystem 606 is communicatively coupled to a number of components including one or more user input devices 608 (e.g., a touchscreen, keyboard, virtual keypad, microphone, etc.), one or more storage media 610 that comprises a software application 612, one or more output devices 614 (e.g., speakers, LEDs, etc.), one or more sensing devices 616, 618, 620, one or more camera or other sensor applications 622 (e.g., software-based sensor controls), and one or more network interfaces 624.

[00025] The storage media 610 may include one or more hard drives or other suitable data storage devices (e.g., flash memory, memory cards, memory sticks, and/or others). In some embodiments, portions of systems software (e.g., an operating system, etc.), framework/middleware (e.g., APIs, object libraries, etc.). Portions of systems software or framework/middleware may be copied to the memory 604 during operation of the computing device 106, for faster processing or other reasons.

[00026] The one or more network interfaces 624 may communicatively couple the computing device 106 to a network, such as a local area network, wide area network, personal cloud, enterprise cloud, public cloud, and/or the Internet, for example. Accordingly, the network interfaces 624 may include one or more wired or wireless network interface cards or adapters, for example, as may be needed pursuant to the specifications and/or design of the particular computing system 600. The network interface(s) 624 may provide short-range wireless or optical communication capabilities using, e.g., Near Field Communication

(NFC), wireless fidelity (Wi-Fi), radio frequency identification (RFID), infrared (IR), or other suitable technology. Further, the wireless communications may use the Zigbee or Z-Wave protocols.

[00027] The other computing system(s) 626 may be embodied as any suitable type of computing system or device such as any of the aforementioned types of devices or other electronic devices or systems. For example, in some embodiments, the other computing systems 626 may include one or more server computers used to store portions of the data stored in storage media 610. Further, computing device 626 may further include application 628 to provide an interface for display to a user to implement the embodiments of the disclosure set forth. The computing system 600 may include other components, sub-components, and devices not illustrated in Figure 6 for clarity of the description. In general, the components of the computing system 600 are communicatively coupled as shown in Figure 6 by electronic signal paths, which may be embodied as any type of wired or wireless signal paths capable of facilitating communication between the respective devices and components.

## **EXAMPLES**

[00028] Illustrative examples of the passive RFID lock disclosed herein are provided below. An embodiment of the passive RFID lock may include any one or more, and any combination of, the examples described below.

[00029] Example 1 is a system comprising a lockset for use with a mobile device. The system comprises a network, a locking device, a passive radio frequency identification (“RFID”) tag and a mobile device. The locking device is movable between a locked position and an unlocked position. The passive RFID tag is affixed to a housing of the locking device.

The mobile device comprises a reader and is configured to: scan the passive RFID tag, automatically transmit one or more notifications, and update a cloud service.

[00030] In Example 2, the subject matter of Example 1 is further configured to include a home automation control device communicatively coupled to the mobile device and configured to perform one or more actions based on a message received from the mobile device.

[00031] In Example 3, the subject matter of Example 1 is further configured such that the one or more notifications are automatically transmitted in response to the passive RFID tag being recognized by a software application of the mobile device.

[00032] In Example 4, the subject matter of Example 3 is further configured such that the one or more notifications include a text message or an email.

[00033] In Example 5, the subject matter of Example 3 is further configured such that the one or more notifications include a social network status update.

[00034] In Example 6, the subject matter of Example 1 is further configured such that the cloud service tracks scan time.

[00035] In Example 7, the subject matter of Example 1 is further configured such that the cloud service tracks audit trail information.

[00036] In Example 8, the subject matter of Example 1 is further configured such that the cloud service issues one or more additional commands based on the lock scan.

[00037] In Example 9, the subject matter of Example 8 is further configured such that the one or more additional commands include a command issued to a home automation controller.

[00038] In Example 10, the subject matter of Example 1 is further configured such that the reader is a near-field communications (NFC) reader.

[00039] Example 11 is a system comprising a lockset for use with a mobile device. The system comprises a network, a locking device, a passive radio frequency identification (“RFID”) tag, and a mobile device. The locking device is movable between a locked position and an unlocked position. The passive RFID tag is affixed to a housing of the locking device. The mobile device comprises a reader and is configured to: scan the passive RFID tag and issue one or more commands to a home automation controller.

[00040] In Example 12, the subject matter of Example 11 is further configured such that the one or more commands are issued via a cloud service.

[00041] In Example 13, the subject matter of Example 11 is further configured such that the one or more commands cause one or more appliances to perform one or more operations.

[00042] In Example 14, the subject matter of Example 13 is further configured such that the one or more appliances are communicatively coupled to the home automation controller.

[00043] In Example 15, the subject matter of Example 11 is further configured such that the reader is a near-field communications (NFC) reader.

[00044] Example 16 is a system comprising a lockset for use with a mobile device. The system comprises a network, a locking device, a passive radio frequency identification (“RFID”) tag, and a mobile device. The locking device is movable between a locked position and an unlocked position. The passive RFID tag is affixed to a housing of the locking device. The mobile device comprises a reader and is configured to: scan the passive RFID tag and launch a command to a cloud service. The locking device is unlocked in response to receiving a verification from an owner of the locking device via the cloud service.

[00045] In Example 17, the subject matter of Example 16 is further configured such that the verification is an authorization of a user of the mobile device.

[00046] In Example 18, the subject matter of Example 16 is further configured such that the locking device is locked and a notification is transmitted to the owner in response to a subsequent scan of the passive RFID tag by the mobile device.

[00047] In Example 19, the subject matter of Example 16 is further configured such that the verification is received via text message.

[00048] In Example 20, the subject matter of Example 16 is further configured such that the reader is a near-field communications (NFC) reader.

WHAT IS CLAIMED IS:

1. A system comprising:
  - a locking device movable between a locked position and an unlocked position;
  - a passive radio frequency identification (“RFID”) tag affixed to a housing of the locking device;
  - the mobile device comprising a reader, the mobile device configured to:
    - scan the passive RFID tag;
    - automatically transmit one or more notifications; and
    - update a cloud service.
2. The system of claim 1, further comprising a home automation control device communicatively coupled to the mobile device and configured to perform one or more actions based on a message received from the mobile device.
3. The system of claim 1, wherein the one or more notifications are automatically transmitted in response to the passive RFID tag being recognized by a software application of the mobile device.
4. The system of claim 3, wherein the one or more notifications include a text message and/or an email.
5. The system of claim 3, wherein the one or more notifications include a social network status update.
6. The system of claim 1, wherein the cloud service tracks scan time.
7. The system of claim 1, wherein the cloud service tracks audit trail information.
8. The system of claim 1, wherein the cloud service issues one or more additional commands based on the scan of the RFID tag.

9. The system of claim 8, wherein the one or more additional commands include a command issued to a home automation controller.
10. The system of claim 1, wherein the reader is a near-field communications (NFC) reader.
11. A system comprising comprising:  
a locking device movable between a locked position and an unlocked position;  
a passive radio frequency identification (“RFID”) tag affixed to a housing of the locking device;  
the mobile device comprising a reader, the mobile device configured to:  
scan the passive RFID tag;  
issue one or more commands to a home automation controller.
12. The system of claim 11, wherein the one or more commands are issued via a cloud service.
13. The system of claim 11, wherein the one or more commands cause one or more appliances to perform one or more operations.
14. The system of claim 13, wherein the one or more appliances are communicatively coupled to the home automation controller.
15. The system of claim 11, wherein the reader is a near-field communications (NFC) reader.
16. A system comprising:  
a locking device movable between a locked position and an unlocked position;  
a passive radio frequency identification (“RFID”) tag affixed to a housing of the locking device;  
the mobile device comprising a reader, the mobile device configured to:  
scan the passive RFID tag; and  
launch a command to a cloud service;



wherein the locking device is unlocked in response to receiving a verification from an owner of the locking device via the cloud service.

17. The system of claim 16, wherein the verification is an authorization of a user of the mobile device.

18. The system of claim 16, wherein the locking device is locked and a notification is transmitted to the owner in response to a subsequent scan of the passive RFID tag by the mobile device.

19. The system of claim 16, wherein the verification is received via text message.

20. The system of claim 16, wherein the reader is a near-field communications (NFC) reader.

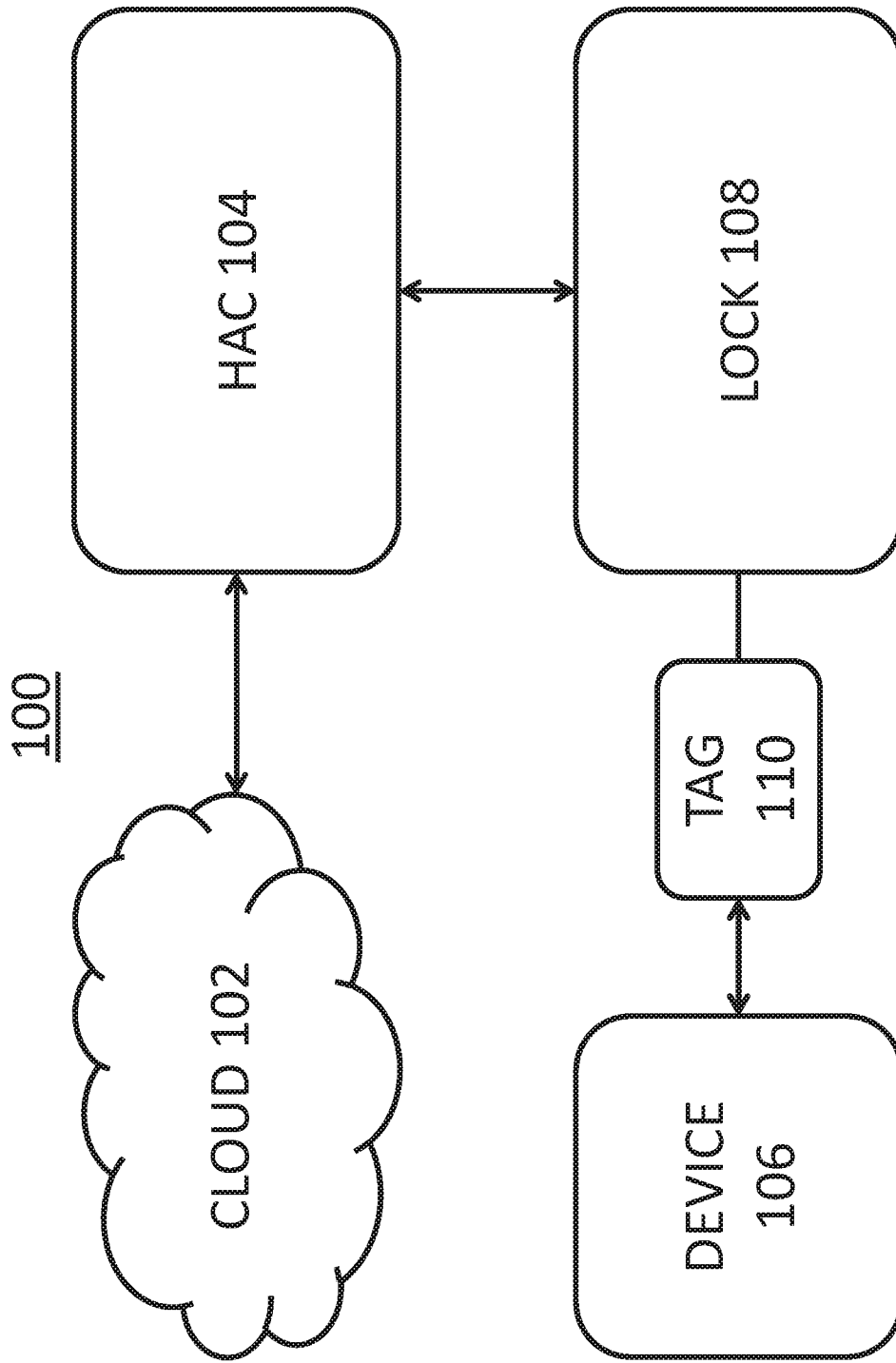

FIGURE 1

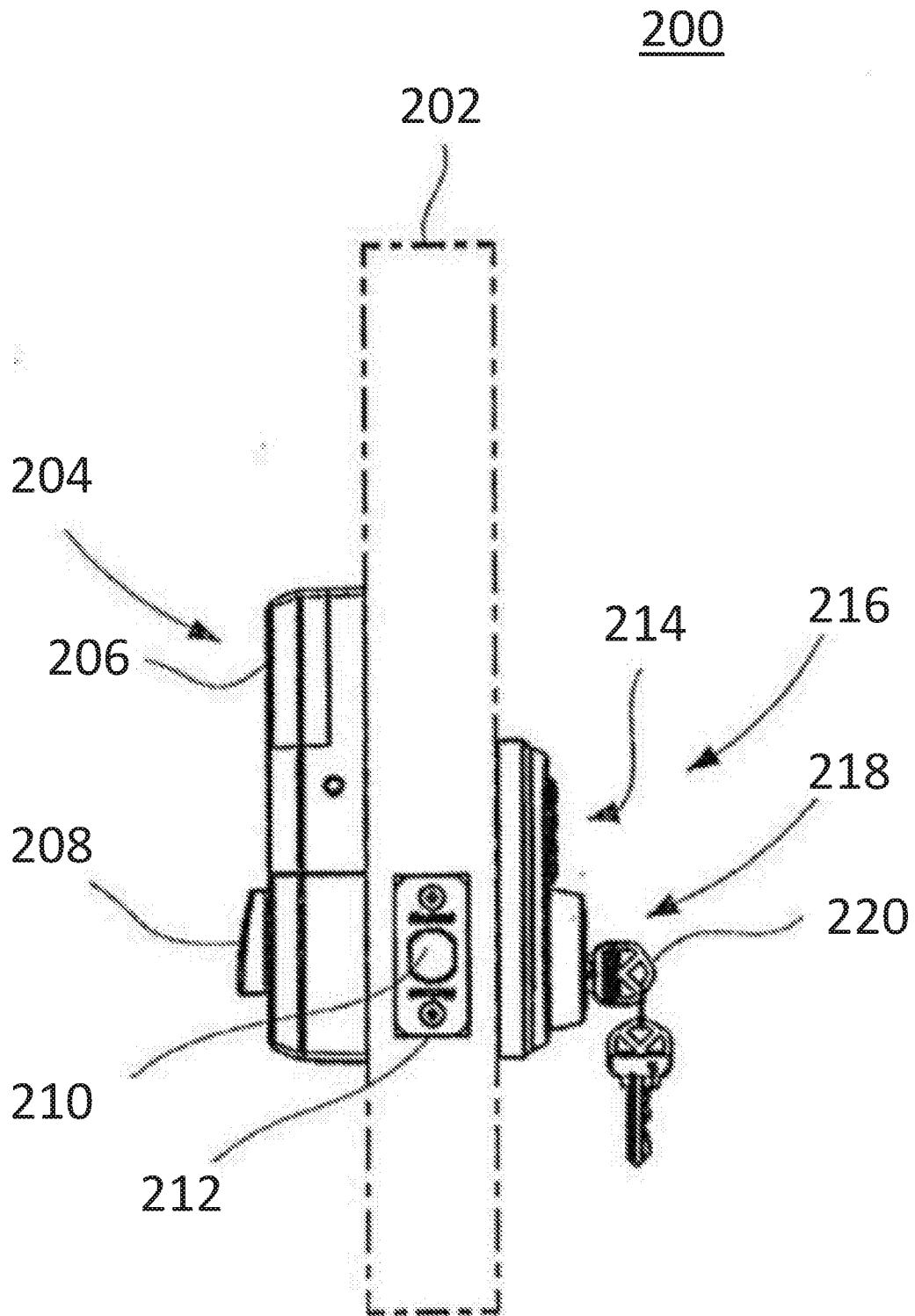

FIGURE 2

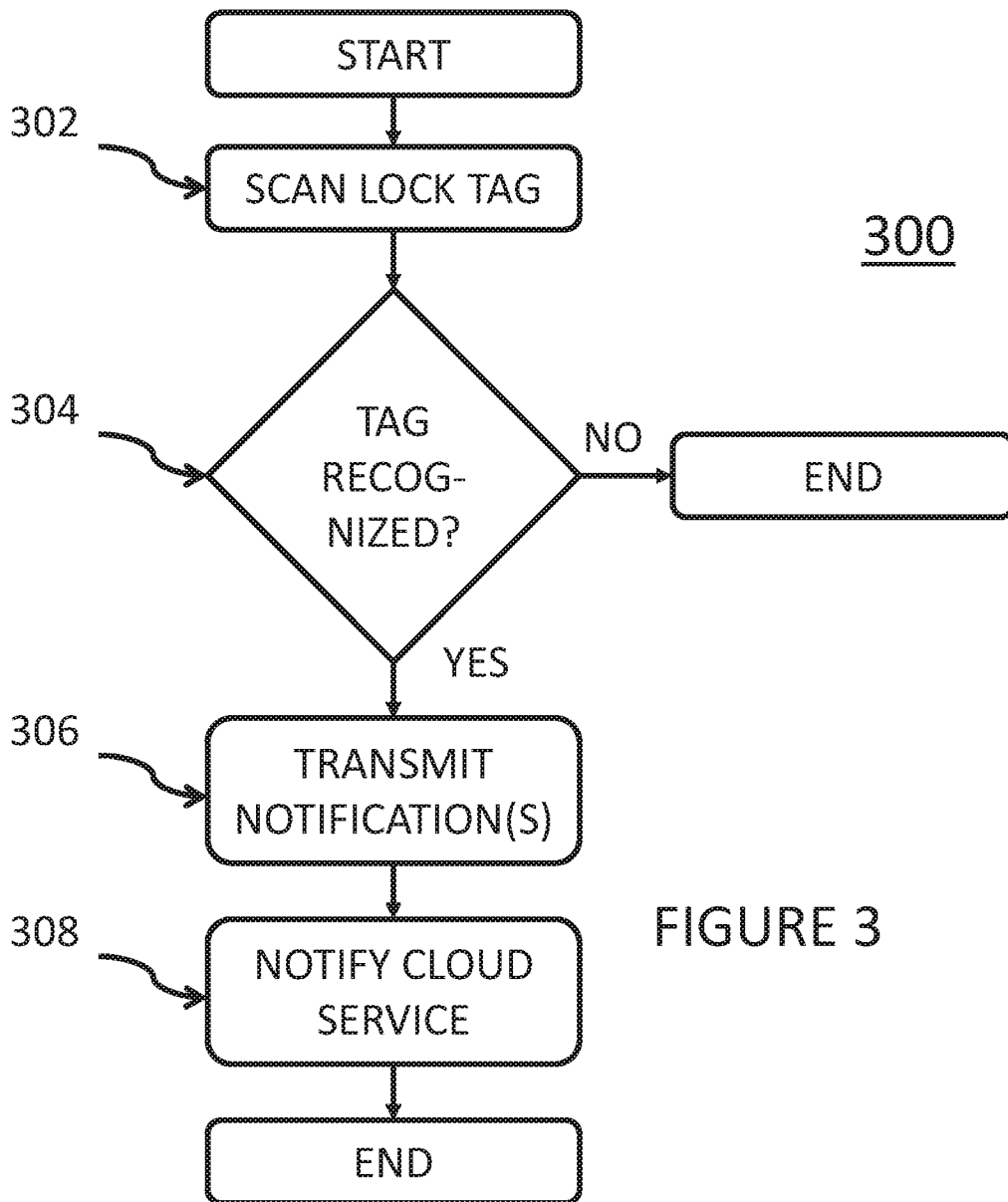

FIGURE 3

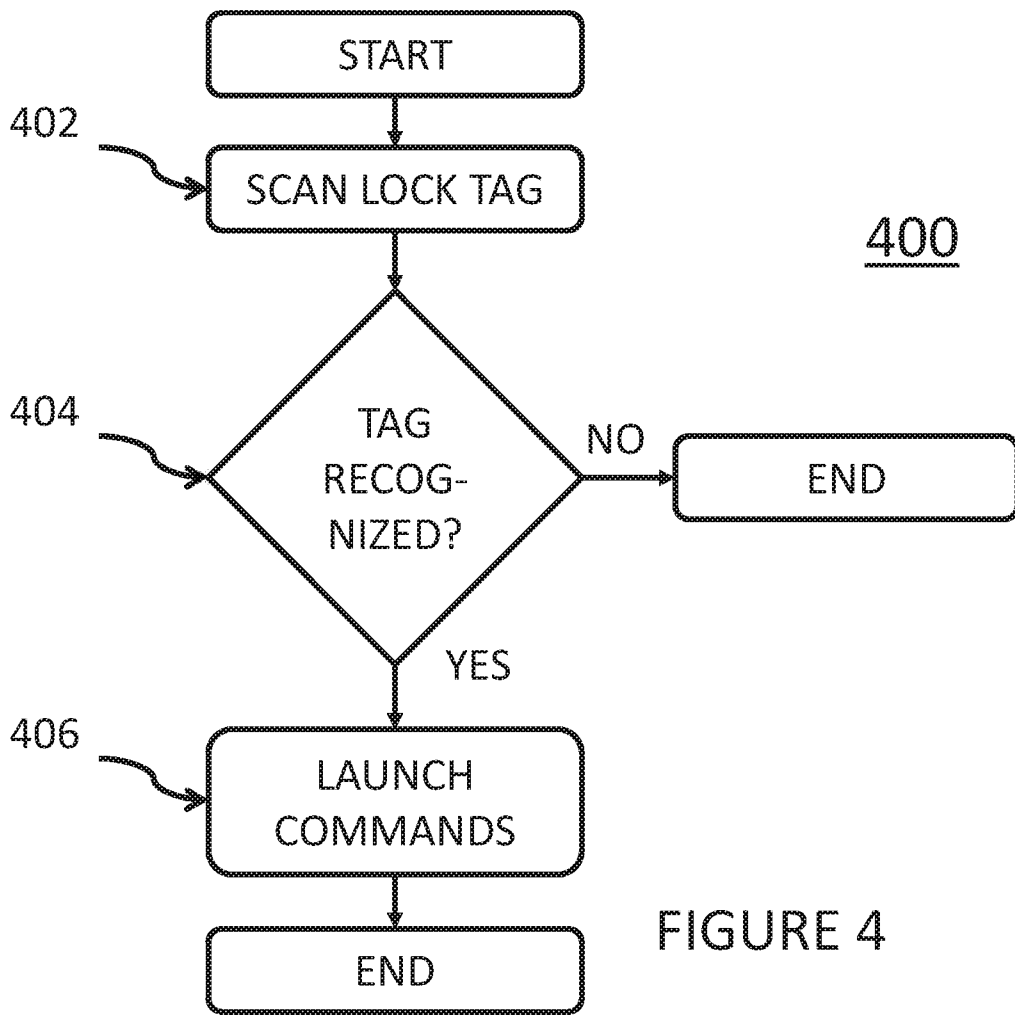

FIGURE 4

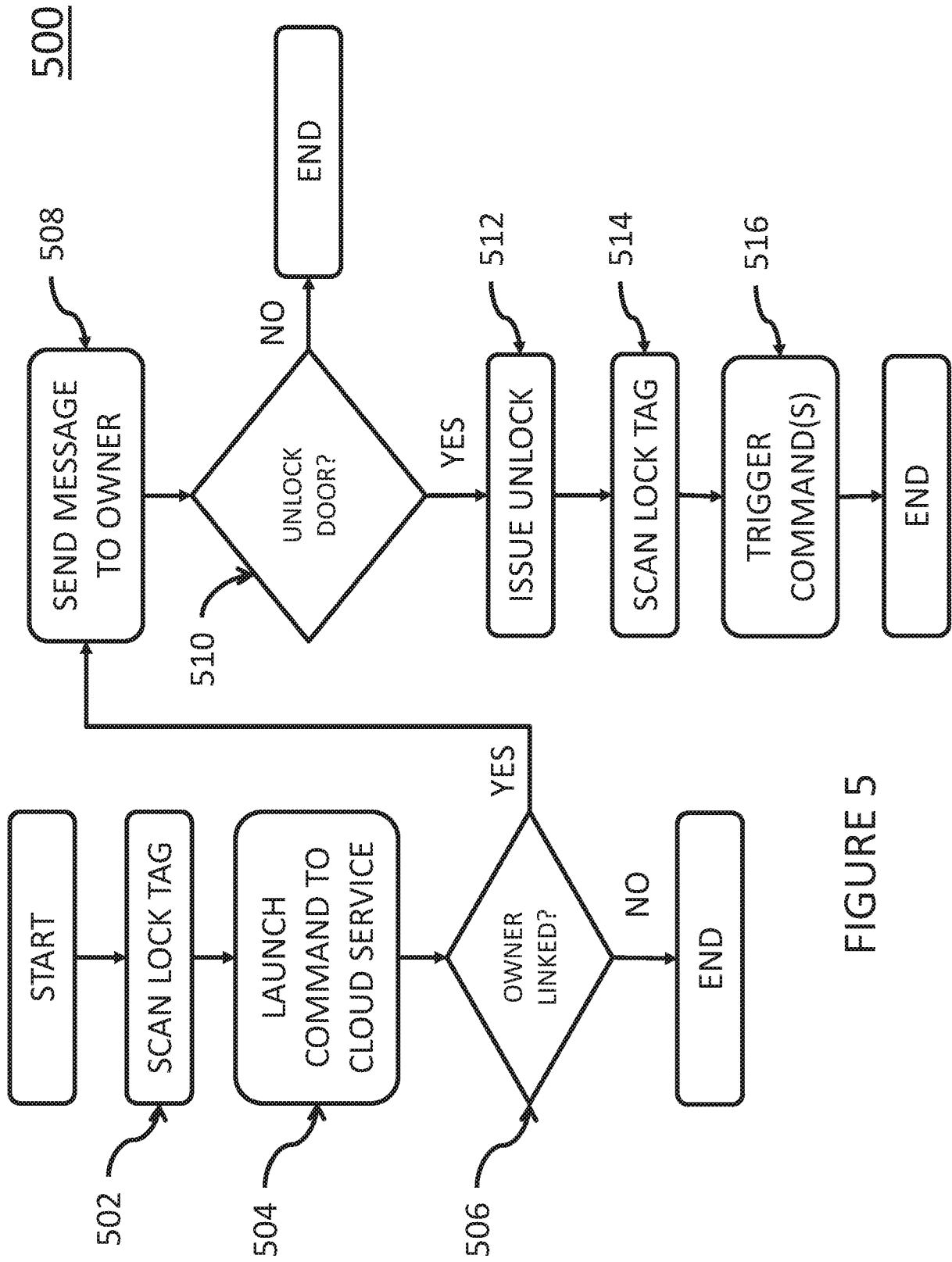

FIGURE 5

600 ↘

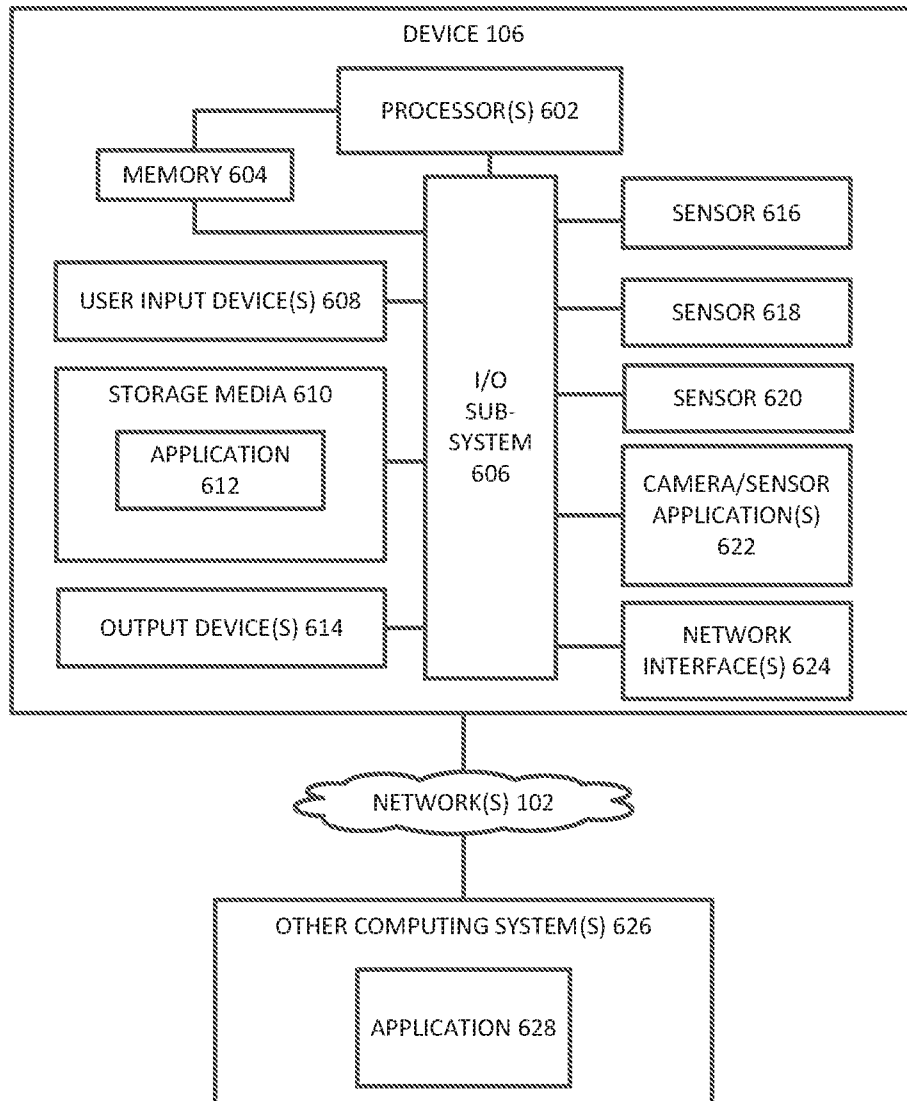



FIGURE 6

<b>A. CLASSIFICATION OF SUBJECT MATTER</b> G07C 9/00(2006.01)i, G06K 19/07(2006.01)i, G08B 25/14(2006.01)i		
According to International Patent Classification (IPC) or to both national classification and IPC		
<b>B. FIELDS SEARCHED</b>		
Minimum documentation searched (classification system followed by classification symbols) G07C 9/00; H04L 9/14; G05B 15/00; G08C 17/02; E05B 47/00; H04W 12/06; G06K 19/07; G08B 25/14		
Documentation searched other than minimum documentation to the extent that such documents are included in the fields searched Korean utility models and applications for utility models Japanese utility models and applications for utility models		
Electronic data base consulted during the international search (name of data base and, where practicable, search terms used) eKOMPASS(KIPO internal) & Keywords: wireless, door, lock, verification, authorization, mobile, tag, scan, cloud		
<b>C. DOCUMENTS CONSIDERED TO BE RELEVANT</b>		
Category*	Citation of document, with indication, where appropriate, of the relevant passages	Relevant to claim No.
Y	US 2015-0101369 A1 (JOSEPH FRANK SCALISI) 16 April 2015 See paragraphs [0060]-[0097], [0111], [0177] and figure 1.	1-20
Y	US 2014-0191848 A1 (KEVIN R. IMES et al.) 10 July 2014 See paragraphs [0014]-[0026] and figures 1-4.	1-20
A	US 2015-0199859 A1 (HONEYWELL INTERNATIONAL INC.) 16 July 2015 See paragraphs [0011]-[0024] and figures 1-2.	1-20
A	US 2015-0269799 A1 (MEGHAN MARTINEZ et al.) 24 September 2015 See paragraphs [0019]-[0036] and figures 1-3.	1-20
A	KR 10-1470747 B1 (S-1 CORPORATION) 08 December 2014 See paragraphs [0021]-[0070] and figures 1-3.	1-20
<input type="checkbox"/> Further documents are listed in the continuation of Box C.		<input checked="" type="checkbox"/> See patent family annex.
* Special categories of cited documents: "A" document defining the general state of the art which is not considered to be of particular relevance "E" earlier application or patent but published on or after the international filing date "L" document which may throw doubts on priority claim(s) or which is cited to establish the publication date of another citation or other special reason (as specified) "O" document referring to an oral disclosure, use, exhibition or other means "P" document published prior to the international filing date but later than the priority date claimed	"T" later document published after the international filing date or priority date and not in conflict with the application but cited to understand the principle or theory underlying the invention "X" document of particular relevance; the claimed invention cannot be considered novel or cannot be considered to involve an inventive step when the document is taken alone "Y" document of particular relevance; the claimed invention cannot be considered to involve an inventive step when the document is combined with one or more other such documents, such combination being obvious to a person skilled in the art "&" document member of the same patent family	
Date of the actual completion of the international search 30 August 2017 (30.08.2017)	Date of mailing of the international search report <b>31 August 2017 (31.08.2017)</b>	
Name and mailing address of the ISA/KR  International Application Division Korean Intellectual Property Office 189 Cheongsa-ro, Seo-gu, Daejeon, 35208, Republic of Korea Facsimile No. +82-42-481-8578	Authorized officer  KIM, Sung Gon  Telephone No. +82-42-481-8746	



**INTERNATIONAL SEARCH REPORT**

Information on patent family members

International application No.

**PCT/US2017/039719**

Patent document cited in search report	Publication date	Patent family member(s)	Publication date
US 2015-0101369 A1	16/04/2015	AU 2014-293304 A1	29/01/2015
		AU 2014-312083 A1	05/03/2015
		CA 2917915 A1	29/01/2015
		CA 2917926 A1	05/03/2015
		CN 105612564 A	25/05/2016
		CN 105684407 A	15/06/2016
		CN 106204974 A	07/12/2016
		CN 106204975 A	07/12/2016
		EP 3025314 A1	01/06/2016
		EP 3039659 A1	06/07/2016
		JP 2010-197264 A	09/09/2010
		JP 5249815 B2	31/07/2013
		US 2011-0311097 A1	22/12/2011
		US 2014-0093123 A1	03/04/2014
		US 2014-0098987 A1	10/04/2014
		US 2015-0027178 A1	29/01/2015
		US 2015-0029008 A1	29/01/2015
		US 2015-0029009 A1	29/01/2015
		US 2015-0029334 A1	29/01/2015
		US 2015-0029335 A1	29/01/2015
		US 2015-0049191 A1	19/02/2015
		US 2015-0054949 A1	26/02/2015
		US 2015-0062337 A1	05/03/2015
		US 2015-0070495 A1	12/03/2015
		US 2015-0077555 A1	19/03/2015
		US 2015-0077567 A1	19/03/2015
		US 2015-0092055 A1	02/04/2015
		US 2015-0109113 A1	23/04/2015
		US 2015-0116490 A1	30/04/2015
		US 2015-0145993 A1	28/05/2015
		US 2015-0228167 A1	13/08/2015
		US 2015-0319411 A1	05/11/2015
		US 2015-0341603 A1	26/11/2015
		US 2015-0371469 A1	24/12/2015
		US 2016-0044287 A1	11/02/2016
		US 2016-0134826 A1	12/05/2016
		US 2016-0258202 A1	08/09/2016
		US 2016-0261824 A1	08/09/2016
		US 2016-0275739 A1	22/09/2016
		US 2016-0284170 A1	29/09/2016
US 2016-0300476 A1	13/10/2016		
US 2016-0330412 A1	10/11/2016		
US 2016-0330413 A1	10/11/2016		
US 2017-0032637 A1	02/02/2017		
US 2017-0084131 A1	23/03/2017		
US 8630447 B2	14/01/2014		
US 8774454 B2	08/07/2014		
US 8780201 B1	15/07/2014		
US 8781157 B2	15/07/2014		

**INTERNATIONAL SEARCH REPORT**

Information on patent family members

International application No.

**PCT/US2017/039719**

Patent document cited in search report	Publication date	Patent family member(s)	Publication date
		US 8823795 B1	02/09/2014
		US 8842180 B1	23/09/2014
		US 8872915 B1	28/10/2014
		US 8937659 B1	20/01/2015
		US 8941736 B1	27/01/2015
		US 8947530 B1	03/02/2015
		US 8953040 B1	10/02/2015
		US 9013575 B2	21/04/2015
		US 9049352 B2	02/06/2015
		US 9053622 B2	09/06/2015
		US 9055202 B1	09/06/2015
		US 9058738 B1	16/06/2015
		US 9060103 B2	16/06/2015
		US 9060104 B2	16/06/2015
		US 9065987 B2	23/06/2015
		US 9094584 B2	28/07/2015
		US 9109378 B2	18/08/2015
		US 9113051 B1	18/08/2015
		US 9113052 B1	18/08/2015
		US 9118819 B1	25/08/2015
		US 9142214 B2	22/09/2015
		US 9160987 B1	13/10/2015
		US 9165444 B2	20/10/2015
		US 9172920 B1	27/10/2015
		US 9172921 B1	27/10/2015
		US 9172922 B1	27/10/2015
		US 9179107 B1	03/11/2015
		US 9179108 B1	03/11/2015
		US 9179109 B1	03/11/2015
		US 9196133 B2	24/11/2015
		US 9197867 B1	24/11/2015
		US 9230424 B1	05/01/2016
		US 9237318 B2	12/01/2016
		US 9247219 B2	26/01/2016
		US 9253455 B1	02/02/2016
		US 9342936 B2	17/05/2016
		US 9508239 B1	29/11/2016
		US 9736284 B2	15/08/2017
		WO 2010-098325 A1	02/09/2010
		WO 2015-013275 A1	29/01/2015
		WO 2015-031812 A1	05/03/2015
		WO 2017-091826 A1	01/06/2017
US 2014-0191848 A1	10/07/2014	US 9716530 B2	25/07/2017
US 2015-0199859 A1	16/07/2015	CA 2876826 A1	10/07/2015
		CN 104778765 A	15/07/2015
		CN 104778765 B	31/05/2017
		EP 2894609 A1	15/07/2015
		IN 81DE2015 A	17/07/2015

**INTERNATIONAL SEARCH REPORT**

Information on patent family members

International application No.

**PCT/US2017/039719**

Patent document cited in search report	Publication date	Patent family member(s)	Publication date
		US 2017-061717 A1 US 9524594 B2	02/03/2017 20/12/2016
US 2015-0269799 A1	24/09/2015	US 2015-0267438 A1 US 2016-0275738 A1 US 9353551 B2 WO 2015-142813 A1	24/09/2015 22/09/2016 31/05/2016 24/09/2015
KR 10-1470747 B1	08/12/2014	None	