



- (51) **International Patent Classification:**
A61B 19/00 (2006.01) B25J 3/00 (2006.01)
- (21) **International Application Number:**
PCT/JP2012/070576
- (22) **International Filing Date:**
6 August 2012 (06.08.2012)
- (25) **Filing Language:** English
- (26) **Publication Language:** English
- (30) **Priority Data:**
61/515,203 4 August 2011 (04.08.2011) US
2012-031959 16 February 2012 (16.02.2012) JP
- (71) **Applicant (for all designated States except US):** OLYMPUS CORPORATION [JP/JP]; 43-2, Hatagaya 2-chome, Shibuya-ku, Tokyo 151-0072 (JP).
- (72) **Inventors; and**
- (75) **Inventors/Applicants (for US only):** INOUE Shintaro [JP/JP]; c/o OLYMPUS CORPORATION, 43-2, Hatagaya

2-chome, Shibuya-ku, Tokyo, 151-0072 (JP). **KISHI Kosuke** [JP/JP]; c/o OLYMPUS CORPORATION, 43-2, Hatagaya 2-chome, Shibuya-ku, Tokyo 151-0072 (JP).

(74) **Agents:** TANAI Sumio et al.; 1-9-2, Marunouchi, Chiyoda-ku, Tokyo, 100-6620 (JP).

(81) **Designated States (unless otherwise indicated, for every kind of national protection available):** AE, AG, AL, AM, AO, AT, AU, AZ, BA, BB, BG, BH, BN, BR, BW, BY, BZ, CA, CH, CL, CN, CO, CR, CU, CZ, DE, DK, DM, DO, DZ, EC, EE, EG, ES, FI, GB, GD, GE, GH, GM, GT, HN, HR, HU, ID, IL, IN, IS, KE, KG, KM, KN, KP, KR, KZ, LA, LC, LK, LR, LS, LT, LU, LY, MA, MD, ME, MG, MK, MN, MW, MX, MY, MZ, NA, NG, NI, NO, NZ, OM, PE, PG, PH, PL, PT, QA, RO, RS, RU, RW, SC, SD, SE, SG, SK, SL, SM, ST, SV, SY, TH, TJ, TM, TN, TR, TT, TZ, UA, UG, US, UZ, VC, VN, ZA, ZM, ZW.

(84) **Designated States (unless otherwise indicated, for every kind of regional protection available):** ARIPO (BW, GH, GM, KE, LR, LS, MW, MZ, NA, RW, SD, SL, SZ, TZ, UG, ZM, ZW), Eurasian (AM, AZ, BY, KG, KZ, RU, TJ,

[Continued on next page]

(54) **Title:** SURGICAL INSTRUMENT AND CONTROL METHOD THEREOF

FIG. 7

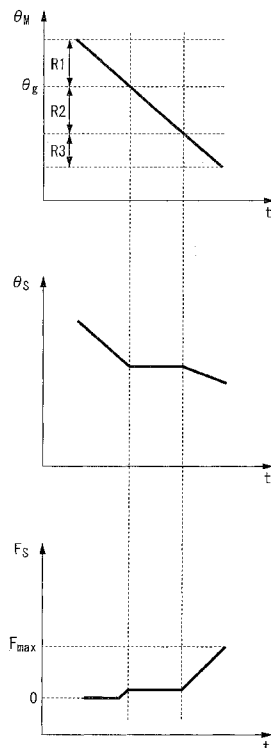

(57) **Abstract:** A surgical instrument includes an end effector that is opened and closed, a manipulation unit that manipulates the end effector in a first direction so that the end effector applies an acting force to a target, a grip detecting unit that acquires an information used to determine whether the end effector applies the acting force to the target, a driving unit that drives the end effector to be opened and closed, and a control unit that controls the driving unit based on the information input to the manipulation unit. When the control unit determines that the end effector is applying the acting force to the target based on the information acquired by the grip detecting unit, the control unit sets an acting force increasing zone of a predetermined range in a first movable range in the first direction of the manipulation unit, sets a neutral zone in a remaining area of the first movable range, controls the driving unit so that the acting force increases with a constant gradient with respect to an amount of manipulation of the manipulation unit in the acting force increasing zone, and controls the driving unit so that the acting force is kept constant regardless of the amount of manipulation of the manipulation unit in the neutral zone.

WO 2013/018935 A1

TM), European (AL, AT, BE, BG, CH, CY, CZ, DE, DK, EE, ES, FI, FR, GB, GR, HR, HU, IE, IS, IT, LT, LU, LV, MC, MK, MT, NL, NO, PL, PT, RO, RS, SE, SI, SK, SM, TR), OAPI (BF, BJ, CF, CG, CI, CM, GA, GN, GQ, GW, ML, MR, NE, SN, TD, TG). **Published:** — *with international search report (Art. 21(3))*

DESCRIPTION

SURGICAL INSTRUMENT AND CONTROL METHOD THEREOF

5 Technical Field

[0001]

The present invention relates to a surgical instrument having an end effector that is opened and closed and a control method thereof.

Priority is claimed on Japanese Patent Application No. 2012-031959, filed
10 February 16, 2012, and U.S. Patent Application No. 61/515203, filed August 4, 2011, the contents of which are incorporated herein by reference.

Background Art

[0002]

15 In the medical field, various surgical instruments are known. A surgical instrument having an end effector that is opened and closed is known as one of such surgical instruments. Since the end effector is used to grip or exclusion body tissue, it is important to appropriately control an acting force such as a gripping force or a displacing force that the end effector applies to the body tissue.

20 [0003]

Patent Document 1 discloses a manipulator system as a surgical instrument in which a gripper as an end effector is driven with a motor. In this manipulator system, a gripping-start angle is recognized on the basis of the output of a gripping-start estimating observer. A control is performed so that the gripping force is increased after gripping is
25 started and a desired gripping force is achieved when the opening angle of the gripper

reaches the most closed angle.

Citation List

Patent Literature

5 [0004]

[Patent Document 1] Japanese Unexamined Patent Application, First
Publication No. 2010-076012

Summary of Invention

10 Problem to be Solved by the Invention

[0005]

In the manipulator system described Patent Document 1, the gripping force is adjusted to reach the maximum gripping force when a trigger of a manipulation unit is pulled to the maximum. Accordingly, when the size of an object to be gripped is
15 changed, there is a problem in that the gradient of the change in gripping force with respect to the amount of manipulation on the gripper varies to change the operational feeling of an operator.

[0006]

The invention is made in consideration of the above-mentioned circumstances
20 and an object thereof is to provide a surgical instrument which can appropriately control an acting force on an end effector without changing the sense of use of an operator and a control method thereof.

Means for solving the Problem

25 [0007]

According to a first aspect of the invention, a surgical instrument including: an end effector that is opened and closed; a manipulation unit configured to manipulate the end effector in a first direction so that the end effector applies an acting force to a target; a grip detecting unit configured to acquire an information used to determine whether the end effector applies the acting force to the target; a driving unit configured to drive the end effector to be opened and closed; and a control unit configured to control the driving unit based on the information input to the manipulation unit, when the control unit determines that the end effector applies the acting force to the target based on the information acquired by the grip detecting unit, the control unit sets an acting force increasing zone of a predetermined range in a first movable range in the first direction of the manipulation unit, sets a neutral zone in a remaining area of the first movable range, controls the driving unit so that the acting force increases with a constant gradient with respect to an amount of manipulation of the manipulation unit in the acting force increasing zone, and controls the driving unit so that the acting force is kept constant regardless of the amount of manipulation of the manipulation unit in the neutral zone.

[0008]

According to a second aspect of the invention, in the first aspect, the acting force increasing zone may be set in an initial area toward the first direction in the first movable range.

According to a third aspect of the invention, in the first aspect or the second aspect, the grip detecting unit may include a camera imaging the end effector.

According to a fourth aspect of the invention, in any one of the first aspect to the third aspect, the grip detecting unit may include a force sensor detecting the acting force.

According to a fifth aspect of the invention, in any one of the first aspect to the fourth aspect, the first movable range of the manipulation unit may be set to be greater

than a movable range of the end effector.

[0009]

According to a sixth aspect of the invention, in the second aspect, the acting force may decrease when the manipulation unit is manipulated in a second direction, and when the manipulation unit may be manipulated in the second direction, the control unit may set an acting force decreasing zone of a predetermined range to an initial area toward the second direction in a second movable range of the second direction of the manipulation unit, and may control the driving unit so that the acting force decreases with a constant gradient with respect to the amount of manipulation of the manipulation unit in the acting force decreasing zone.

[0010]

According to a seventh aspect of the invention, a control method of a surgical instrument having an end effector that is opened and closed and a manipulation unit configured to manipulate the end effector in a first direction so that the end effector applies an acting force to a target, the control method includes: repeatedly determining whether the end effector applies the acting force to the target; when determining that the end effector applies the acting force to the target, setting an acting force increasing zone of a predetermined range in a first movable range in the first direction of the manipulation unit, setting a neutral zone in a remaining area of the first movable range; causing the acting force to increase with a constant gradient with respect to an amount of manipulation of the manipulation unit in the acting force increasing zone; and causing the acting force to be kept constant regardless of the amount of manipulation of the manipulation unit in the neutral zone.

25 Advantageous Effects of Invention

[0011]

According to the surgical instrument and the control method thereof, it is possible to appropriately control an acting force on an end effector without changing the sense of use of an operator.

5

Brief Description of Drawings

[0012]

FIG. 1 is a diagram schematically illustrating the configuration of a medical master-slave manipulator according to a first embodiment of the invention.

10 FIG. 2 is an enlarged view illustrating a grip section of the medical master-slave manipulator.

FIG. 3 is a diagram schematically illustrating the structure of a distal end of a slave arm in the medical master-slave manipulator.

15 FIG. 4 is a block diagram illustrating the functional relation of a manipulator controller, a distal end of a slave arm, and a treatment tool in the medical master-slave manipulator.

FIG. 5 is a diagram illustrating the correspondence of the manipulation on an end effector manipulating part and the movement of an acting part of a treatment tool.

FIG. 6 is a diagram illustrating a state where the acting portion grips a target.

20 FIG. 7 is an example of a graph illustrating the relationship of an opening angle of an opening and closing member, an opening angle of an end effector, and a gripping force in the medical master-slave manipulator.

25 FIG. 8 is a block diagram illustrating the functional relation of a manipulator controller, a distal end of a slave arm, and a treatment tool in a medical master-slave manipulator according to a second embodiment of the invention.

FIG. 9 is an example of a graph illustrating the relationship of an opening angle of an opening and closing member, an opening angle of an end effector, and a gripping force in the medical master-slave manipulator.

FIG. 10 is an example of a graph illustrating the relationship of an opening angle of an opening and closing member, an opening angle of an end effector, and a gripping force in a medical master-slave manipulator according to a third embodiment of the invention.

FIG. 11 is an example of a graph illustrating the relationship of an opening angle of an opening and closing member, an opening angle of an end effector, and a gripping force according to a modified example of the medical master-slave manipulator.

FIG. 12 is a diagram illustrating the correspondence of the manipulation on an end effector manipulating part and the movement of an acting part of a treatment tool in a medical master-slave manipulator according to a fourth embodiment of the invention.

FIG. 13 is a diagram illustrating a state where the acting part presses a target.

FIG. 14 is an example of a graph illustrating the relationship of an opening angle of an opening and closing member, an opening angle of an end effector, and a gripping force in the medical master-slave manipulator.

FIG. 15 is a block diagram illustrating the functional relation of a manipulator controller, a distal end of a slave arm, and a treatment tool in a medical master-slave manipulator according to a modified example of the invention.

Description of Embodiments

[0013]

Hereinafter, a first embodiment of the invention will be described. FIG. 1 is a diagram illustrating a medical master-slave manipulator (hereinafter, simply referred to

as a “master-slave manipulator”) 1 which is a surgical instrument according to this embodiment. The master-slave manipulator 1 includes a master input unit 2 having a master arm 21 and outputting a manipulation command and a slave manipulator 3 having a slave arm 31. The master-slave manipulator 1 remotely controls the slave arm 31 to follow the manipulation of the master arm 21 by an operator (user) Op. The manipulation command from the master arm 21 is transmitted to a master controller 41 of a control unit 4 and is input to a manipulator controller 42. Thereafter, a motion signal is sent from the manipulator controller 42 to the slave manipulator 3 and the slave arm 31 moves.

10 [0014]

As shown in FIG. 1, the slave manipulator 3 is installed in an operating table 100 on which a patient P is placed and includes plural slave arms 31. Each slave arm has plural multi-degree-of-freedom joints and can move multi-axially. The multi-degree-of-freedom joints are individually driven by a power unit not shown. For example, a motor (servo motor) having a servo mechanism including an incremental encoder or a decelerator can be used as the power unit.

[0015]

One of the plural slave arms 31 is provided with observation device not shown such as an endoscope that captures an image of the field of operation related to a manipulation target site and the other slave arm is provided with a treatment tool performing a variety of treatment to be described later. Known observation device can be appropriately selected and used as the observation device. Each slave arm includes a drive source that drives the treatment tool and the like. For example, a servo motor can be used as the drive source. In the following description, the slave arm provided with a treatment tool out of the slave arms may be also referred to as a “slave arm for

20
25

treatment”.

[0016]

The master input unit 2 includes plural master arms 21 to be manipulated by an operator Op and a display unit 22 on which an image acquired by the observation device. Each master arm 21 has a known configuration which can multi-axially move and a grip section (manipulation unit) 21A which is gripped by the operator at a tip end close to the operator Op. The display unit 22 is constructed by a known display or the like and displays an image of a field of operation acquired by the observation device. In this embodiment, two images having a difference corresponding to parallax are projected onto the display unit 22 and the operator Op can stereoscopically view an image through the use of known 3D glasses 101 having a polarizing mechanism, a shutter mechanism, or the like.

[0017]

FIG. 2 is an enlarged view of the grip section 21A. The grip section 21A includes a grip body 25 to be gripped by the operator Op and an end effector manipulating part (manipulation unit) 26 to be opened and closed by the operator.

The operator Op grips the grip body 25 with his or her hand. The joints of the master arm 21 move with the change in the position and the orientation of the grip body 25, when the position and the orientation of the grip section 21A is changed with the movement of a wrist, an elbow, and a shoulder. The degrees of movement of the joints are detected by position detectors disposed around the joints and a manipulation signal corresponding to the degrees of movement is input to the master controller 41.

Thereafter, the slave arm 31 corresponding to the master arm is driven in response to the signal sent from the manipulator controller 42, and the position and the orientation of the end effector of the treatment tool attached to the slave arm correspond to the position and

the orientation of the grip body 25.

The end effector manipulating part 26 includes a base 26a and a pair of opening and closing members 26b and 26c opening and closing with respect to the base 26a at the same angle. The opening angle of the opening and closing members 26b and 26c about the base 26a is detected by detection device such as a encoder not shown and is transmitted to the master controller 41.

[0018]

FIG. 3 is a diagram schematically illustrating the structure of a distal end of the treatment slave arm 31. A treatment tool 50 is attached to the distal end of the treatment slave arm 31. In this embodiment, the treatment tool 50 is detachably attached to the treatment slave arm 31, but may not be attached and detached necessarily.

The treatment tool 50 includes an acting part (end effector) 51, a drive link 52, and a driving part 53 sequentially from the distal end directed to a body cavity of a patient P to the proximal end connected to the treatment slave arm 31. The drive link 52 and the driving part 53 are contained in a cylindrical chassis 54.

The acting part 51 includes, for example, a pair of jaws 51A and 51B that can be opened and closed. When the pair of jaws is closed, the acting part interposes and grips a target such as body tissue or a curved needle therebetween and applies a gripping force (acting force) to the target. The driving part 53 is a rod-shaped member and is connected to a drive rod (to be described later) in the slave arm 31 when the treatment tool 50 is connected to the slave arm 31. The driving part 53 advances or retreats a protopodite of the drive link 52 in the axis direction of the chassis 54 through driving force transmitted from the drive rod. Accordingly, the driving part 53 opens and closes the acting part 51. The drive link 52 connects the acting part 51 and the driving part 53 and a known link mechanism can be used.

[0019]

A drive rod 34, a linear encoder 35, a linear driving mechanism 36, and a motor (driving unit) 37 are disposed at the distal end of the slave arm 31. The linear driving mechanism 36 has a known configuration including a ball screw 36a and a linear driving block 36b and converts the rotational movement of the motor 37 into the advance or retreat movement of the linear driving block 36b, which opens and closes the acting part 51. The proximal end of the drive rod 34 is connected to the linear driving block 36b, advances or retreats in the length direction thereof with the advance or retreat movement of the linear driving block 36b to cause the driving part 53 of the connected treatment tool 50 to advance or retreat. The amount of movement of the drive rod 34 is detected by the linear encoder 35.

[0020]

FIG. 4 is a block diagram illustrating the functional relation of the manipulator controller 42, the distal end of the slave arm 31, and the treatment tool 50. Accordingly, connections to joints other than the manipulator controller 42 and the distal end of the slave arm are not shown.

A camera (grip detecting unit) 61 imaging the state of the acting part 51 of the treatment tool 50 and a motor controller 62 controlling the driving of the motor 37 based on input information input to the grip section 21A are disposed at the distal end of the slave arm 31. The camera 61 and the motor controller 62 are connected to the manipulator controller 42. The camera 61 images the acting part 51 at a predetermined time interval such as several tens of millimeter seconds (msec) and sequentially transmits the acquired images to the manipulator controller 42 as an information used to determine whether the acting part 51 grips a target. The motor controller 62 controls the current value applied to the motor 37 and the current application time in response to a command

from the manipulator controller 42 and controls the magnitude of the driving force generated in the motor 37 and the driving time.

[0021]

The operation of the master-slave manipulator 1 having the above-mentioned
5 configuration will be described below.

An operator Op manipulates a master arm 21 to cause a corresponding treatment
slave arm 31 to move and to cause the acting part 51 of the attached treatment tool 50 to
approach a gripping target such as body tissue or a curved needle. When the operator
grips the opening and closing members 26b and 26c of the end effector manipulating part
10 26 in a state where the gripping target is located between a pair of jaws 51A and 51B of
the acting part 51, the angle (opening angle) formed by the opening and closing members
26b and 26c gradually decreases. This change is transmitted to the master controller 41
and the manipulator controller 42 as a detection value of the detection device. The
manipulator controller 42 creates a control signal to be transmitted to the motor controller
15 62 based on the state of the end effector manipulating part 26 and the image transmitted
from the camera 61, and transmits the created control signal to the motor controller 62.
A mode of creating the control signal to be transmitted to the motor controller 62 will be
described below in detail.

[0022]

20 The manipulator controller 42 sequentially processes the images transmitted
from the camera 61 and repeatedly determines whether a target is gripped between a pair
of jaws 51A and 51B. A control signal to be transmitted to the motor controller 62 is
created so that the amount of manipulation on the end effector manipulating part 26 and
the amount of opening and closing of the acting part 51 have predetermined
25 correspondence until the pair of jaws 51A and 51B comes in contact with the target to

grip the target between the pair of jaws 51A and 51B. As a result, as shown in FIG. 5, the pair of jaws 51A and 51B is closed in accordance with the amount of closing of the opening and closing members 26b and 26c of the end effector manipulating part 26. At this time, the variation in opening angle (hereinafter, also referred to as an
5 “opening-closing member opening angle”) of the opening and closing members 26b and 26c of the end effector manipulating part 26 the variation in opening angle of the pair of jaws 51A and 51B may correspond to each other in a one-to-one manner or may correspond to each other with a predetermined coefficient multiplied thereby.

In this embodiment, the opening angle of the pair of jaws 51A and 51B is
10 controlled by controlling the driving of the motor 37 in response to the control signal to the motor controller 62. Alternatively, the opening angle of the pair of jaws may be controlled through an image process on the image acquired by the camera 61 or the opening angle of the pair of jaws may be controlled based on the detection value of the linear encoder 35.

15 [0023]

As shown in FIG. 6, when the manipulator controller 42 determines that a gripping target Sb comes in contact with the pair of jaws 51A and 51B and is gripped between the pair of jaws 51A and 51B, the manipulator controller 42 switches the mode of creating a control signal to be transmitted to the motor controller 62.

20 The manipulator controller 42 compares the present value of the opening-closing member opening angle with the structural minimum value of the opening-closing member opening angle, sets a gripping force increasing zone of a predetermined range in a movable range (first movable range) in the closing direction (first direction) of the opening and closing members 26b and 26c at the gripping-start time point, and sets a
25 neutral zone in the other range. The above-mentioned minimum value may be negative

when the opening and closing members 26b and 26c can be further manipulated to the closing direction even after the opening and closing members 26b and 26c are parallel to the base 26a.

[0024]

5 The “neutral zone” in the first embodiment of the invention means a zone in which a non-zero gripping force (acting force) applied to a target from the acting part 51 does not vary even when the opening and closing members 26b and 26c are manipulated in the movable range of the opening and closing members 26b and 26c.

10 In this embodiment, a predetermined angle range (for example, 30 degrees) from the minimum value of the opening angle of the opening and closing members is set as the “gripping force increasing zone” in which the opening-closing member opening angle is proportional to the gripping force, and the other angle range, that is, the angle range from the present opening-closing member opening angle to the gripping force increasing zone, is set as the neutral zone.

15 [0025]

 When the opening-closing member opening angle is in the neutral zone, the opening angle (hereinafter, also referred to as an “end effector opening angle”) of the pair of jaws 51A and 51B continues to be controlled and the manipulator controller 42 controls the motor controller 62 so that the opening angle does not vary and the gripping force does not vary. For example, a control signal is created to apply low current of an extent not to increase the gripping force to the motor 37.

[0026]

25 When an operator closes the opening and closing members 26b and 26c and the opening-closing member opening angle enters the gripping force increasing zone, the manipulator controller 42 creates a control signal so that the gripping force increases in

proportion to the variation of the opening-closing member opening angle in the closing direction and the gripping force reaches a predetermined upper limit when the opening-closing member opening angle becomes the minimum value. In this embodiment, the control signal is created so that the current value increases as the opening and closing members 26b and 26c become closed based on the relational expression of a predetermined motor driving current value and the gripping force.

[0027]

FIG. 7 is an example of a graph illustrating the relationship of the opening-closing member opening angle, the end effector opening angle, and the gripping force, where the opening-closing member opening angle θ_M is shown at the upper stage, the end effector opening angle θ_S is shown at the middle stage, and the gripping force F_S is shown at the lower stage. In a first zone R1 before a target is gripped by the acting part 51 ($\theta_M > \theta_g$ at the gripping-start time) out of the movable range of the opening and closing members, the opening-closing member opening angle θ_M is proportional to the end effector opening angle θ_S . In the first zone R1, since a target is not gripped, the gripping force F_S is basically zero. A gripping force is slightly generated before and after the boundary between the first zone R1 in which a target is gripped and the neutral zone R2.

[0028]

In the neutral zone R2 subsequent to the first zone R1, as the opening-closing member opening angle θ_M decreases, the end effector opening angle θ_S is constant and the gripping force F_S does not increase but is kept constant.

[0029]

In the gripping force increasing zone (acting force increasing zone) R3

subsequent to the neutral zone R2, as the opening-closing member opening angle θ_M decreases, the gripping force FS increases with a constant gradient and reaches the maximum gripping force F_{max} at the end of the gripping force increasing zone R3. The behavior of the end effector opening angle θ_S in the gripping force increasing zone R3 varies depending on the rigidity of the gripping target. For example, when the rigidity is high, the target is not deformed and thus the end effector opening angle θ_S has a tendency to hardly vary. However, when the rigidity of the target is low, the target is deformed with the increase in gripping force and thus the end effector opening angle θ_S decreases by a predetermined degree depending on the rigidity.

10 [0030]

As described above, in the master-slave manipulator 1 according to this embodiment, it is determined that the gripping of a target by the acting part 51 is started based on the image from the camera 61. Accordingly, the master controller 41 and the manipulator controller 42 of the control unit 4 controls the motor 37 to control the movement of the acting part 51 so that a predetermined angle range in the movable range of the end effector manipulating part 26 of the master arm 21 in the closing direction at that time is set to the gripping force increasing zone and the other range is set to the neutral zone. As a result, the gripping force applied to the acting part 51 when the end effector manipulating part 26 is manipulated in a predetermined angle range becomes the maximum gripping force F_{max} and the gradient indicating the relationship between the amount of manipulation of the end effector manipulating part 26 and the amount of increase of the gripping force in the gripping force increasing zone is constant, regardless of the size of the gripping target.

Therefore, it is possible to provide a surgical instrument which can be suitably

controlled so that the gripping force applied to the acting part 51 is not excessive and in which the operational feeling of an operator does not vary even when the gripping target is changed.

[0031]

5 In the surgical instrument according to the embodiment of the invention, it is necessary to set the movable ranges of the manipulation unit (the end effector manipulating part 26) and the acting part 51 and the correspondence thereof so as to set the gripping force increasing zone of a predetermined angle range for the manipulation unit even when a possible smallest gripping target is gripped. For example, the
10 movable angle range of the manipulation unit may be set to be greater than the movable range of the acting part 51, or the ratio of the amount of manipulation of the manipulation unit and the amount of opening and closing of the acting part 51 may be adjusted to set the acting part to be opened and closed by a predetermined multiple of the amount of manipulation of the manipulation unit. The specific example thereof is not particularly
15 limited.

[0032]

A second embodiment of the invention will be described below with reference to FIGS. 8 and 9. A master-slave manipulator 71 according to this embodiment is different from the master-slave manipulator 1, in the configuration of the grip detecting unit and
20 the positional relation between the gripping force increasing zone and the neutral zone in the movable range of the manipulation unit. In the following description, the same elements as described above are referenced by the same reference numerals and description thereof will not be repeated.

[0033]

25 FIG. 8 is a block diagram illustrating the functional relation of the manipulator

controller 42, the distal end of the slave arm 31, and the treatment tool 50 in the master-slave manipulator 71. In FIG. 8, similarly to FIG. 4, connections to joints other than the manipulator controller 42 and the distal end of the slave arm are not shown.

In this embodiment, the slave manipulator 31 does not include a camera 61.

5 On the other hand, a force sensor 72 detecting a gripping force applied between a pair of jaws 51A and 51B is provided as the grip detecting unit to the acting part 51 of the treatment tool 50. The value detected by the force sensor 72 is sequentially transmitted to the manipulator controller 42.

[0034]

10 The operation of the master-slave manipulator 71 according to this embodiment will be described below.

The manipulator controller 42 determines that a target is gripped between a pair of jaws 51A and 51B when the force sensor 72 starts detecting of the gripping force (when the gripping force becomes non-zero) with normal reference to the value detected
15 by the force sensor 72.

[0035]

FIG. 9 is an example of a graph illustrating the relationship of the opening-closing member opening angle, the end effector opening angle, and the gripping force in the master-slave manipulator 71, and the display pattern thereof is substantially
20 the same as shown in FIG. 7. In this embodiment, the manipulator controller 42 sequentially sets the gripping force increasing zone R3 and the neutral zone R4 in the closing direction of the opening and closing members 26b and 26c in the movable range (first movable range). Specifically, as shown in FIG. 9, the gripping force increasing zone R3 of a predetermined angle range is set just after the first zone R1. Accordingly,
25 the manipulator controller 42 creates a control signal and transmits the created control

signal to the motor controller 62, so that as the opening-closing member opening angle θ_M decreases after it is determined that a target is gripped between a pair of jaws 51A and 51B, the gripping force F_S increases with a constant gradient and reaches the maximum gripping force F_{max} at the end of the gripping force increasing zone R3. The gripping force applied to the acting part 51 is controlled based on the value detected by the force sensor 72. A known feedback control may be applied to this control.

[0036]

The movable range in the closing direction of the end effector manipulating part 26 after the value of the gripping force F_S reaches F_{max} is the neutral zone R4. In the neutral zone R4, the gripping force F_S is kept F_{max} regardless of the decrease of the opening-closing member opening angle θ_M . Since the manipulator controller 42 controls only the value of the gripping force F_S based on the value detected by the force sensor 72, the manipulator controller does not directly control the end effector opening angle θ_s , but the end effector opening angle θ_s is almost constant in the neutral zone R4.

[0037]

In the master-slave manipulator 71 according to this embodiment, similarly to the master-slave manipulator 1 according to the first embodiment, it is possible to provide a surgical instrument which can be suitably controlled so that the gripping force applied to the acting part is not excessive and in which the operational feeling of an operator Op does not vary even when the gripping target is changed.

[0038]

After it is determined that the gripping of a target is started, the gripping force increasing zone R3 is first set in the movable range in the closing direction of the end effector manipulating part 26. Accordingly, when the operator Op closes the end effector manipulating part 26 after gripping the target, the gripping force applied to the

acting part 51 increases at once. Therefore, the operator Op can perform the manipulation more intuitively.

Since the gripping force F_S in the gripping force increasing zone R3 is controlled based on the value detected by the force sensor 72 disposed in the acting part 51, it is possible to more accurately control the gripping force.

[0039]

In this embodiment, the example in which the control of the gripping force is performed based on the value detected by the force sensor 72 is explained, but this configuration is not necessary. That is, although the accuracy is slightly low, it is possible to control the gripping force by controlling a drive current value of the motor 37, similarly to the first embodiment.

[0040]

A third embodiment of the invention will be described below with reference to FIG. 10. A master-slave manipulator according to this embodiment is different from the above-mentioned embodiments, in that a gripping force increasing zone and a neutral zone are set for the manipulation in addition to a control of the closing direction of the end effector manipulating part.

[0041]

The mechanical structure of the master-slave manipulator according to this embodiment is the same as the master-slave manipulator 71 according to the second embodiment, and the control of the manipulation in the closing direction of the end effector manipulating part 26 is the same as in the second embodiment. In this embodiment, the manipulation in the opening direction (second direction) of the end effector manipulating part 26 is additionally subjected to a predetermined control.

[0042]

FIG. 10 is an example of a graph illustrating the relationship of the opening-closing member opening angle, the end effector opening angle, and the gripping force in the master-slave manipulator according to this embodiment, and the display pattern thereof is substantially the same as shown in FIG. 9. In FIG. 10, the relationship of the opening-closing member opening angle θ_M , the end effector opening angle θ_S , and the gripping force F_S in the manipulation of the opening direction subsequently to the neutral zone R4 in the manipulation of the closing direction is shown.

[0043]

When the gripping force F_S decreases based on the value detected by the force sensor 72, the manipulator controller 42 determines that the manipulation of the end effector manipulating part 26 is performed in the opening direction and applies the control in the opening direction to creating a drive signal to the motor driver 62. As shown in FIG. 10, a gripping force decreasing zone (acting force decreasing zone) R5 of a predetermined range is first set as the initial zone in the opening direction in the movable range (second movable range) in the opening direction. In the gripping force decreasing zone R5, as the opening-closing member opening angle θ_M increases, the gripping force F_S decreases with a constant gradient until the gripping force becomes zero.

[0044]

Subsequently to the gripping force decreasing zone R5, a second zone R6 in which the end effector opening angle θ_S increases with a constant gradient with the increase of the opening-closing member opening angle θ_M is set. In the second zone R6, the acting part 51 is separated from a gripping target and the grip is released. Similarly to the first embodiment, the end effector opening angle θ_S in the second zone R6 is

controlled by controlling the drive current of the motor 37. After the acting part 51 is opened to the maximum, the other movable range in the opening direction of the opening and closing members 26b and 26c is set to a margin zone R7 in which the acting part 51 does not move with the manipulation of the opening and closing members 26b and 26c.

5 [0045]

The angle range of the gripping force decreasing zone R5 varies depending on the state of the end effector manipulating part 26 just before performing the manipulation in the opening direction. In the example shown in FIG. 10, since the end effector manipulating part 26 is manipulated in the closing direction up to the limit of the

10 movable range including the neutral zone R4 and is then manipulated in the opening direction, the angle range of the gripping force decreasing zone R5 is matched with the gripping force increasing zone R3. For example, when the end effector manipulating part 26 is manipulated, for example, by 15 degrees in the closing direction up to the

15 middle of the gripping force increasing zone R3 and is then manipulated in the opening direction, the angle range of the gripping force decreasing zone R5 is set to 15 degrees which is the same as the amount of manipulation in the closing direction in the gripping force increasing zone R2.

The gradient with which the gripping force decreases in the gripping force decreasing zone R5 is set to a value obtained by multiplying the gradient, with which the

20 gripping force increases in the gripping force increasing zone R3, by -1. By employing this configuration, the operational feeling given to the operator Op when increasing and decreasing the gripping force can be made to be constant in both the opening direction and the closing direction of the end effector manipulating part 26.

[0046]

25 In the master-slave manipulator according to this embodiment, similarly to the

master-slave manipulators according to the above-mentioned embodiments, it is possible to provide a surgical instrument which can be suitably controlled so that the gripping force applied to the acting part is not excessive and in which the operational feeling of an operator Op does not vary even when the gripping target is changed.

5 [0047]

The gripping force decreasing zone R5 is set just after the manipulation in the opening direction of the end effector manipulating part 26 is started, and the manipulator controller 42 performs a control so that the variation gradient of the gripping force becomes the value obtained by multiplying the gradient in the gripping force increasing zone by -1. Accordingly, even in the operation of alternately repeating the manipulation in the closing direction and the manipulation in the opening direction to finely adjust the gripping force of the acting part, it is possible to suitably maintain the operator Op' operational feeling.

[0048]

15 In this embodiment, the example in which the gripping force decreasing zone R5 is set just after the manipulation in the opening direction of the end effector manipulating part 26 is started is explained, but the control in the opening direction is not limited to this configuration.

In a modified example shown in FIG. 11, since a neutral zone R8 is set just after the manipulation in the opening direction is started, the gripping force decreasing zone R5 and the second zone R6 are set subsequently thereto, the correspondence of the control details with the opening angle of the opening and closing members 26b and 26c is completely constant in both the closing direction and the opening direction. By employing this control, unlike FIG. 10, even when the manipulation in the opening direction is performed after the end effector manipulating part 26 is closed to the limit,

20

25

the opening-closing member opening angle at the time of releasing the grip and the opening-closing member opening angle at the time of starting the grip are matched with each other. Accordingly, this modified example is suitable for the case where the operator Op prefers the correspondence between the opening-closing member opening angle and the end effector opening angle as the operational feeling.

[0049]

The information of the detection device disposed in the grip section 21A may be used instead of the value detected by the force sensor 72 to detect that the end effector manipulating part 26 is manipulated in the opening direction.

10 [0050]

A fourth embodiment of the invention will be described below with reference to FIGS. 12 to 14. A master-slave manipulator according to this embodiment is different from the master-slave manipulator according to the above-mentioned embodiments, in the use pattern of the attached treatment tool.

15 [0051]

FIG. 12 is a diagram schematically illustrating a treatment tool 80 and an end effector manipulating part 90 in this embodiment. An acting part 81 includes a pair of jaws 81A and 81B similarly to the above-mentioned treatment tool 50, but the pair of jaws 81A and 81B does not grip a target but is used to press and widen the target by opening. In correspondence therewith, a pair of opening and closing members 90b and 90c of the end effector manipulating part 90 is closed in the initial state and the operator Op opens the opening and closing members 90b and 90c to open the pair of jaws 81A and 81B. A hook may be appropriately provided to the pair of opening and closing members 90b and 90c so as to facilitate the opening manipulation.

25 In the master-slave manipulator according to this embodiment having the

above-mentioned treatment tool 80 attached thereto, a pressing force acting on a target is controlled as an acting force by opening the pair of jaws 81A and 81B. Since the pressing force applied to the acting part 81 increases with the manipulation in the opening direction of the end effector manipulating part 90, the opening direction is the first direction.

[0052]

In the master-slave manipulator according to this embodiment, as shown in FIG. 13, when a pressing target Sb1 comes in contact with the outside surfaces in the opening and closing direction of the pair of jaws 81A and 81B, the manipulator controller 42 determines that the pressing on the pressing target Sb1 is started. This determination may be performed using an image acquired with the camera or the like or may be performed based on the value detected by the force sensor or the like. However, since a widening treatment tool such as the treatment tool 80 often starts the pressing manipulation after the pair of jaws in a closed state is inserted into a gap between two tissues coming in contact therewith, it is not easy to determine the pressing start through the image process. Therefore, it is preferable that a reactive force acting on the pair of jaws from the pressing target be detected by the use of a force sensor or the like to determine that the start of the pressing.

[0053]

FIG. 14 is an example of a graph illustrating the relationship of the opening-closing member opening angle, the end effector opening angle, and the gripping force in the master-slave manipulator according to this embodiment. The display pattern thereof is substantially the same as shown in FIG. 9 or the like, but the pressing force F_{S1} which is an acting force is a force acting in the opposite direction of the pressing force F_S and is thus expressed by a negative value.

[0054]

As shown in FIG. 14, the control in the opening direction of the pair of opening and closing members 90b and 90c is substantially the same as the control in the closing direction of the opening and closing members 90b and 90c in the second embodiment.

5 That is, a first zone R1a in which the opening-closing member opening angle θ_M is proportional to the end effector opening angle θ_S , a pressing force increasing zone R9 in which the pressing force increases to the maximum pressing force F_{max} with a constant gradient, and a neutral zone R10 in which the pressing force is maintained in F_{max} regardless of the value of the opening-closing member opening angle θ_M are sequentially
10 set from the side on which the opening angle of the pair of opening and closing members 90b and 90c is the smallest.

Accordingly, when the pair of opening and closing members 90b and 90c is manipulated in the opening direction by a predetermined angle range from the time point at which the pressing is started, the correspondence between the amount of manipulation
15 of the opening and closing members 90b and 90c and the pressing force is controlled so that the value of the pressing force becomes the maximum pressing force F_{max} . As a result, it is possible to maintain a predetermined operational feeling regardless of the type of the pressing target.

[0055]

20 In this way, the surgical instrument and the control method thereof according to the above-mentioned embodiments of the invention can be applied to a surgical instrument having an end effector applying an acting force on a target by opening the end effector.

[0056]

25 In this embodiment, the example in which the control is performed on only the

manipulation in the opening direction in which the acting force increases is explained.

In the same way of the third embodiment, in addition to the opening direction, the control may be performed in the closing direction of the pair of opening and closing members, which is the opposite direction. Similarly to the first embodiment, the order of the neutral zone and the pressing force increasing zone may be inverted.

[0057]

While the embodiments of the invention have been described, the technical scope of the invention is not limited to the embodiments, but various modifications may be added to the elements or may be deleted, or the configurations of the embodiments may be combined without departing from the concept of the invention.

[0058]

For example, as shown in a modified example shown in FIG. 15, both the camera 61 and the force sensor 72 may be provided as the grip detecting unit. In this case, when determining whether the acting part comes in contact with a target, the manipulator controller appropriately selectively uses the image acquired by the camera 61 and the detection value of the force sensor 72 to be used or performs the determination based on both information pieces. Accordingly, it is possible to perform a more appropriate control.

[0059]

Two neutral zones may be set with the acting force increasing zone interposed therebetween. Particularly, when a neutral zone of a small angle range (for example, of about several degrees) is disposed between a zone such as the first zone in which the acting part comes in contact with a target and the acting force increasing zone, the neutral zone serves as a "margin" and a non-gripped state can be smoothly transferred to a gripped state, thereby improving the operational feeling.

[0060]

When the neutral zone precedes the acting force increasing zone after the acting part comes in contact with a target, it may be difficult to see the boundary between the neutral zone and the acting force increasing zone. Accordingly, when the amount of manipulation of the manipulation unit reaches the boundary, a signal which can be recognized by the operator may be sent. The type of the signal is not particularly limited, but all the types of signals such as a visual signal of light or the like, an auditory signal of sound or the like, and a signal for causing the movement of the opening and closing members to be heavier for a quick moment can be used.

Similarly, when the neutral zone is set subsequent to the acting force increasing zone and a signal which can be recognized by an operator is sent at the boundary between the acting force increasing zone and the neutral zone, the operator does not manipulate the manipulation unit to the limit to further increase the acting force even in the neutral zone. As a result, it is possible to suppress an unnecessary manipulation.

[0061]

The surgical instrument according to the embodiments of the invention is not limited to the master-slave manipulators described in the above-mentioned embodiments. The surgical instrument according to the invention may be applied to, for example, a surgical instrument in which the manipulation part and the end effector are disposed in the same body and a remote manipulation is not performed.

[0062]

The manipulation unit is not limited to the configuration having a pair of opening and closing members. For example, a configuration including a manipulation member which can get closer to and be separated from a base and opening and closing the acting part by bringing the manipulation member closer to and separated from the

base may be used. Various manipulations such as a sliding manipulation, a twisting manipulation, and a pushing manipulation in the first direction and the second direction may be employed instead of the closing manipulation and the opening manipulation.

[0063]

5 The maximum value of the acting force may be set to a desired value through the use of various input mechanisms such as a switch or a dial or a user interface displayed on the display unit.

Industrial Applicability

10 [0064]

According to the surgical instrument and the control method thereof, it is possible to appropriately control an acting force on an end effector without changing the sense of use of an operator.

15 Reference Signs List

[0065]

1, 61, 71: MEDICAL MASTER-SLAVE MANIPULATOR

4: CONTROL UNIT

26, 90: END EFFECTOR MANIPULATING PART (MANIPULATION

20 UNIT)

37: MOTOR (DRIVING UNIT)

51, 81: ACTING PART (END EFFECTOR)

61: CAMERA (GRIP DETECTING UNIT)

72: FORCE SENSOR (GRIP DETECTING UNIT)

25 Sb: GRIPPING OBJECT (TARGET)

Sb1: PRESSING OBJECT (TARGET)

FS: GRIPPING FORCE (ACTING FORCE)

FS1: PRESSING FORCE (ACTING FORCE)

R3, R9: ACTING FORCE INCREASING ZONE

5 R2, R4, F8, F10: NEUTRAL ZONE

R5: ACTING FORCE DECREASING ZONE

CLAIMS

1. A surgical instrument comprising:

an end effector that is opened and closed;

5 a manipulation unit configured to manipulate the end effector in a first direction so that the end effector applies an acting force to a target;

a grip detecting unit configured to acquire an information to determine whether the end effector applies the acting force to the target;

a driving unit configured to drive the end effector to be opened and closed; and

10 a control unit configured to control the driving unit based on the information input to the manipulation unit,

wherein when the control unit determines that the end effector applies the acting force to the target based on the information acquired by the grip detecting unit, the control unit

15 sets an acting force increasing zone of a predetermined range in a first movable range in the first direction of the manipulation unit,

sets a neutral zone in a remaining area of the first movable range,

controls the driving unit so that the acting force increases with a constant gradient with respect to an amount of manipulation of the manipulation unit in the acting force increasing zone, and

20 controls the driving unit so that the acting force is kept constant regardless of the amount of manipulation of the manipulation unit in the neutral zone.

2. The surgical instrument according to claim 1, wherein the acting force

25 increasing zone is set in an initial area toward the first direction in the first movable

range.

3. The surgical instrument according to claim 1 or 2, wherein the grip detecting unit includes a camera imaging the end effector.

5

4. The surgical instrument according to any one of claims 1 to 3, wherein the grip detecting unit includes a force sensor detecting the acting force.

5. The surgical instrument according to any one of claims 1 to 4, wherein the first movable range of the manipulation unit is set to be greater than a movable range of the end effector.

6. The surgical instrument according to claim 2, wherein the acting force decreases when the manipulation unit is manipulated in a second direction, and wherein when the manipulation unit is manipulated in the second direction, the control unit

sets an acting force decreasing zone of a predetermined range to an initial area toward the second direction in a second movable range of the second direction of the manipulation unit, and

controls the driving unit so that the acting force decreases with a constant gradient with respect to the amount of manipulation of the manipulation unit in the acting force decreasing zone.

7. A control method of a surgical instrument having an end effector that is opened and closed and a manipulation unit configured to manipulate the end effector in a

first direction so that the end effector applies an acting force to a target, the control method comprising:

repeatedly determining whether the end effector applies the acting force to the target;

5 when determining that the end effector applies the acting force to the target, setting an acting force increasing zone of a predetermined range in a first movable range in the first direction of the manipulation unit,

setting a neutral zone in a remaining area of the first movable range;

causing the acting force to increase with a constant gradient with

10 respect to an amount of manipulation of the manipulation unit in the acting force increasing zone; and

causing the acting force to be kept constant regardless of the amount of manipulation of the manipulation unit in the neutral zone.

FIG. 1

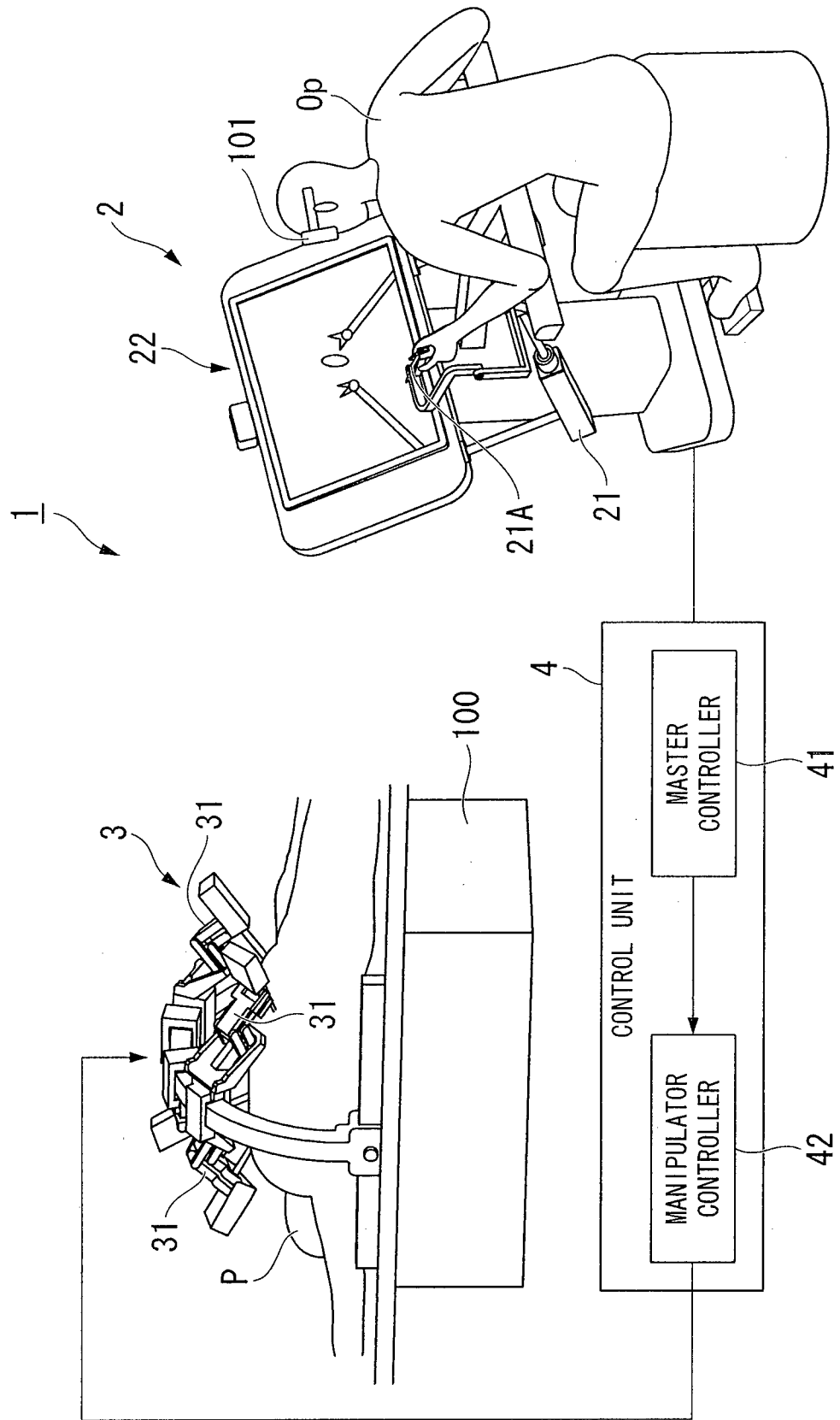

FIG. 2

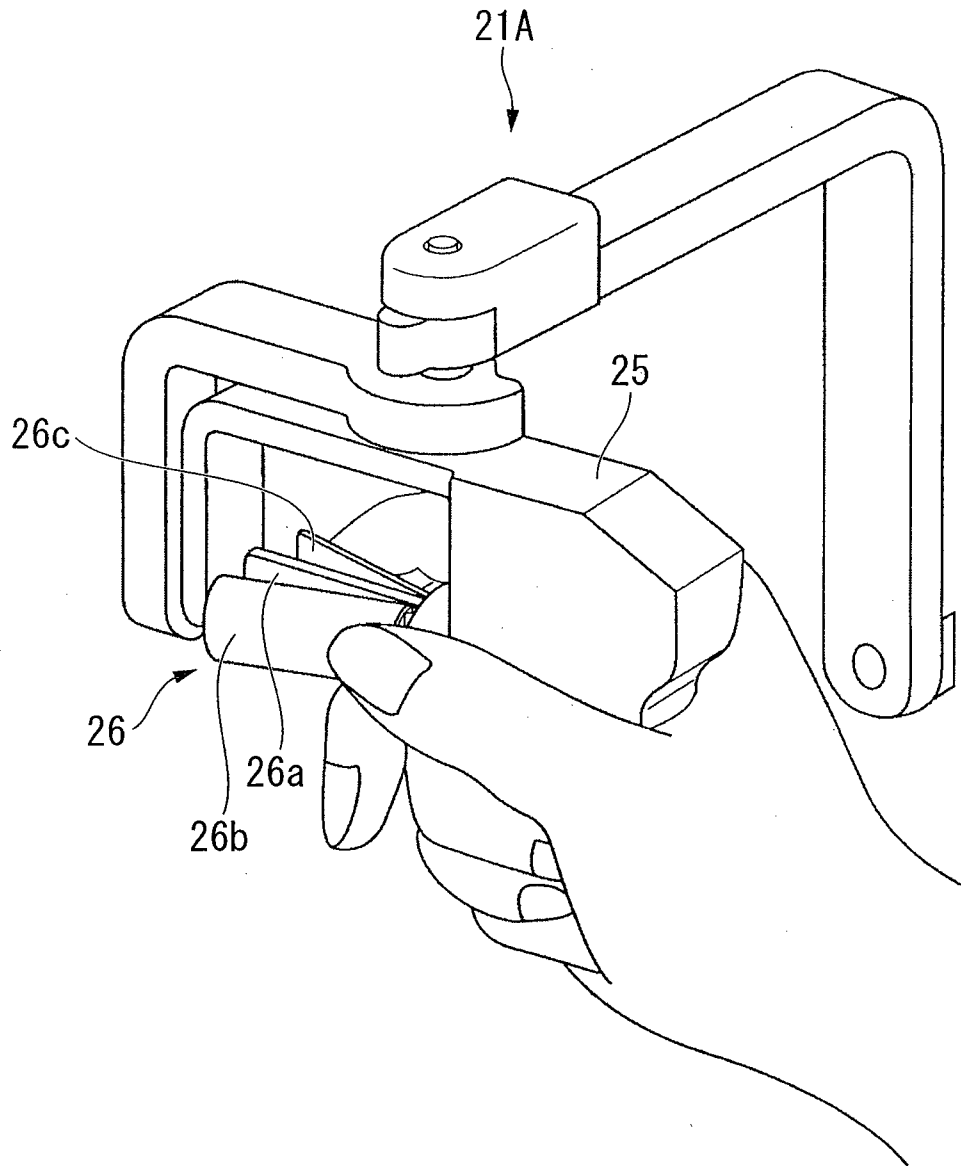

FIG. 3

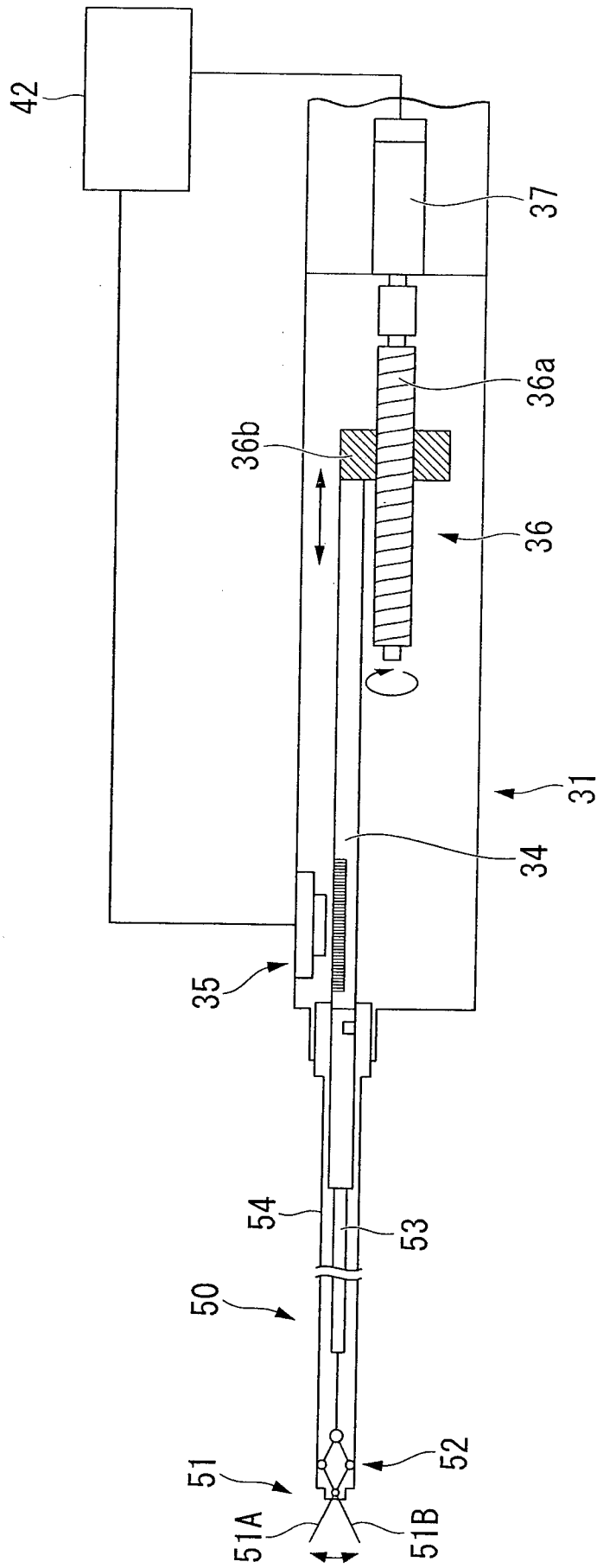

FIG. 4

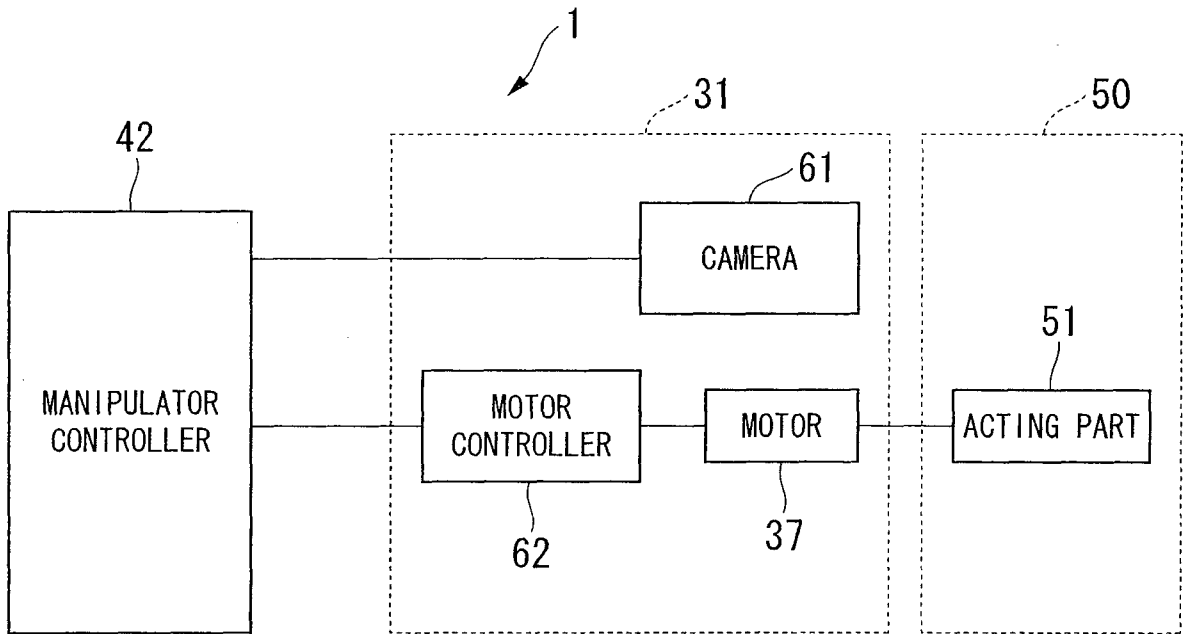

FIG. 5

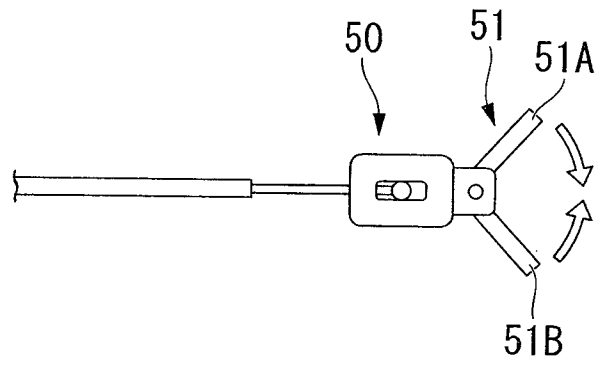
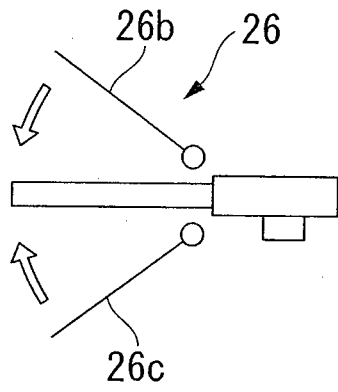

FIG. 6

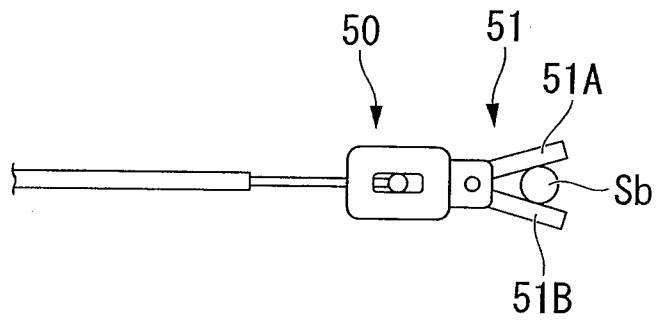

FIG. 7

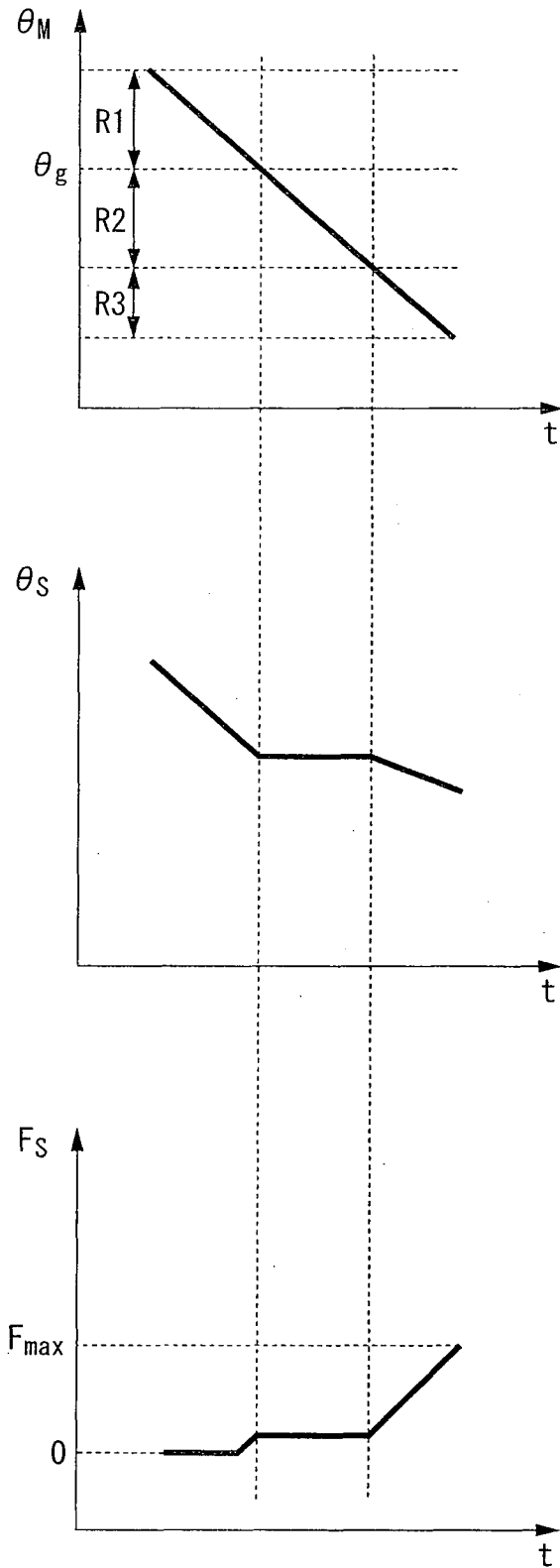

FIG. 8

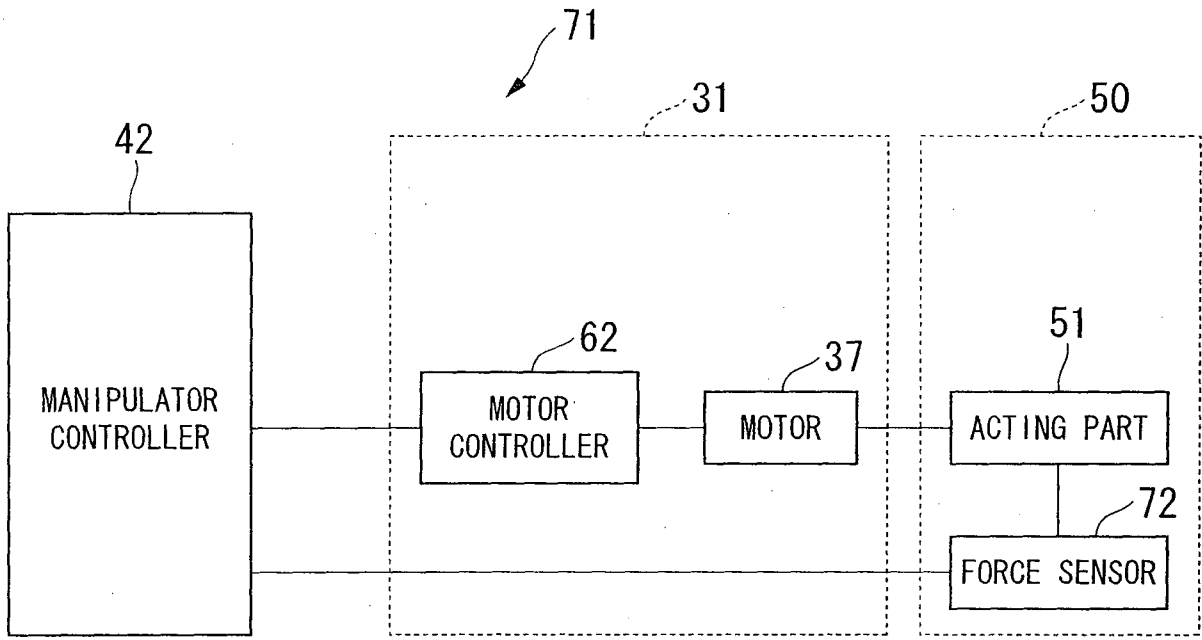

FIG. 9

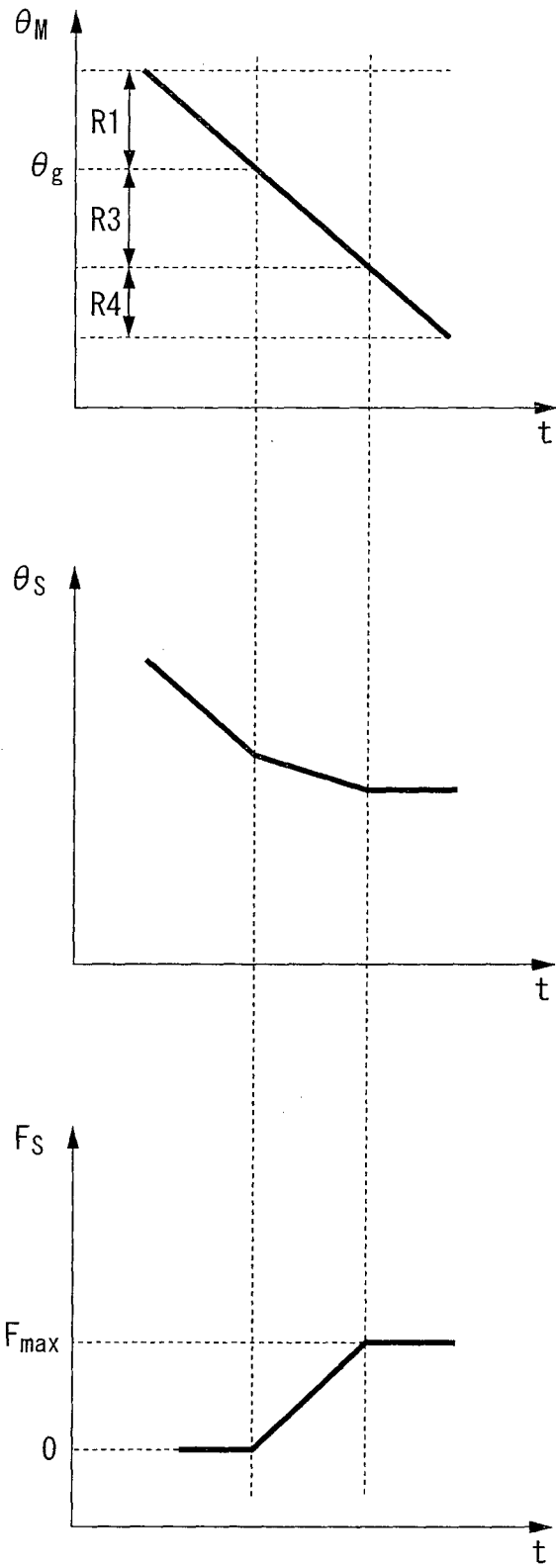

FIG. 10

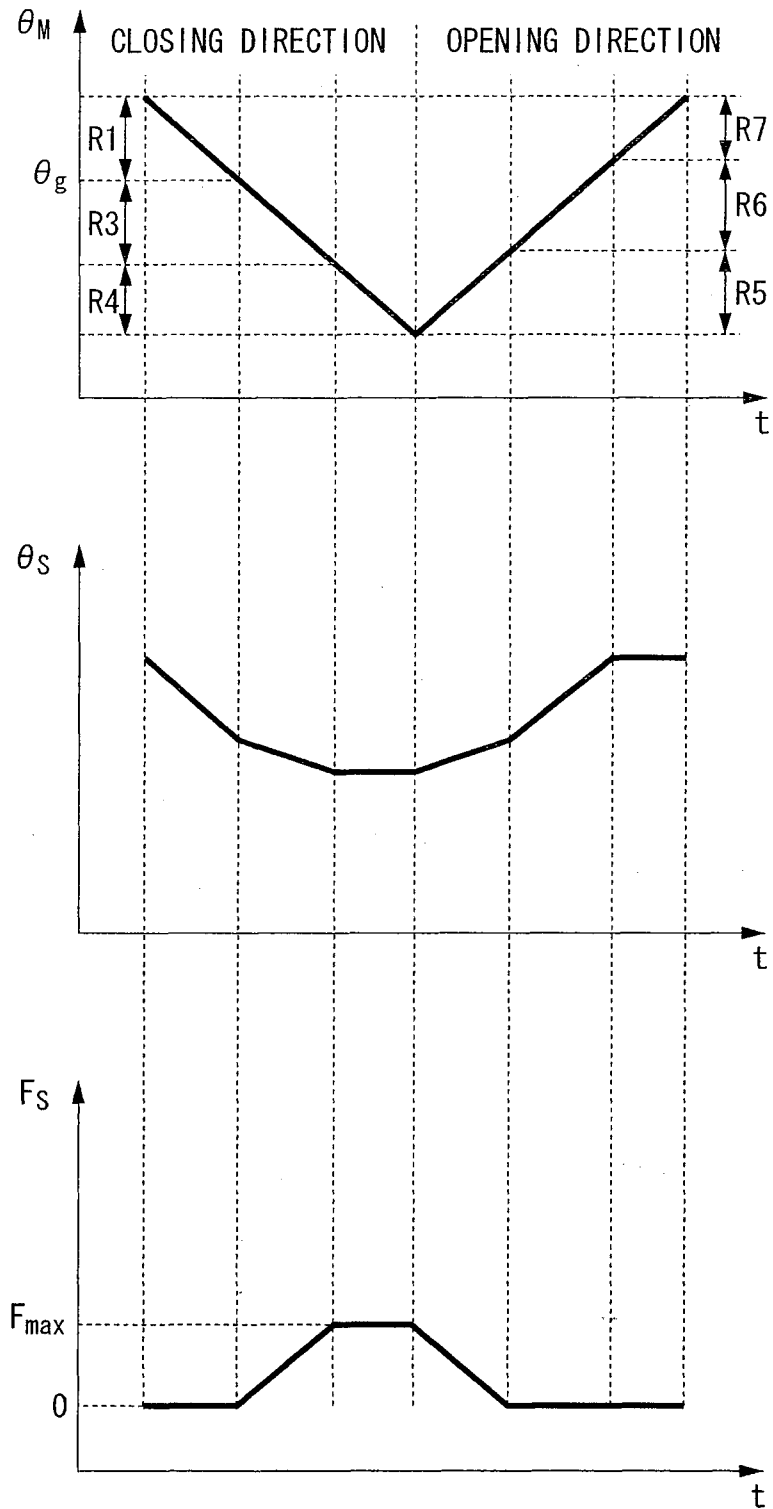

FIG. 11

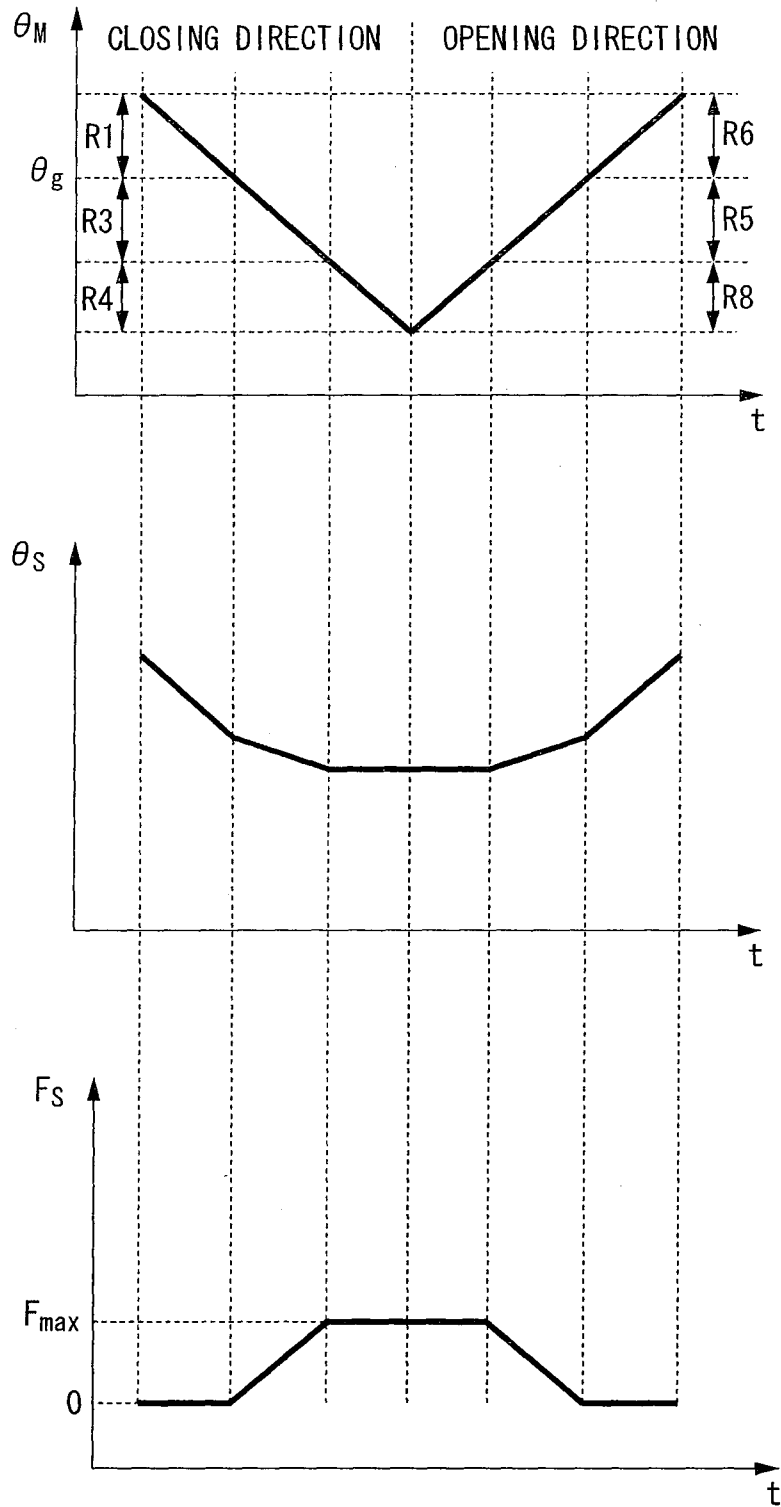

FIG. 12

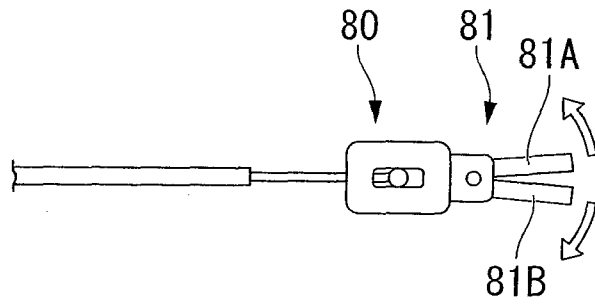
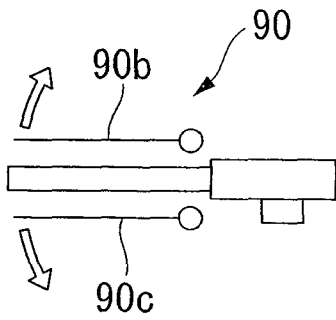

FIG. 13

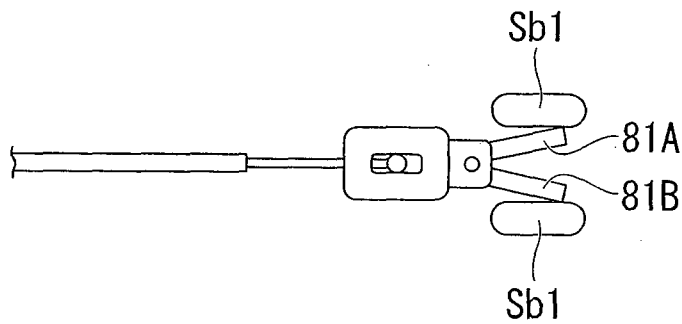

FIG. 14

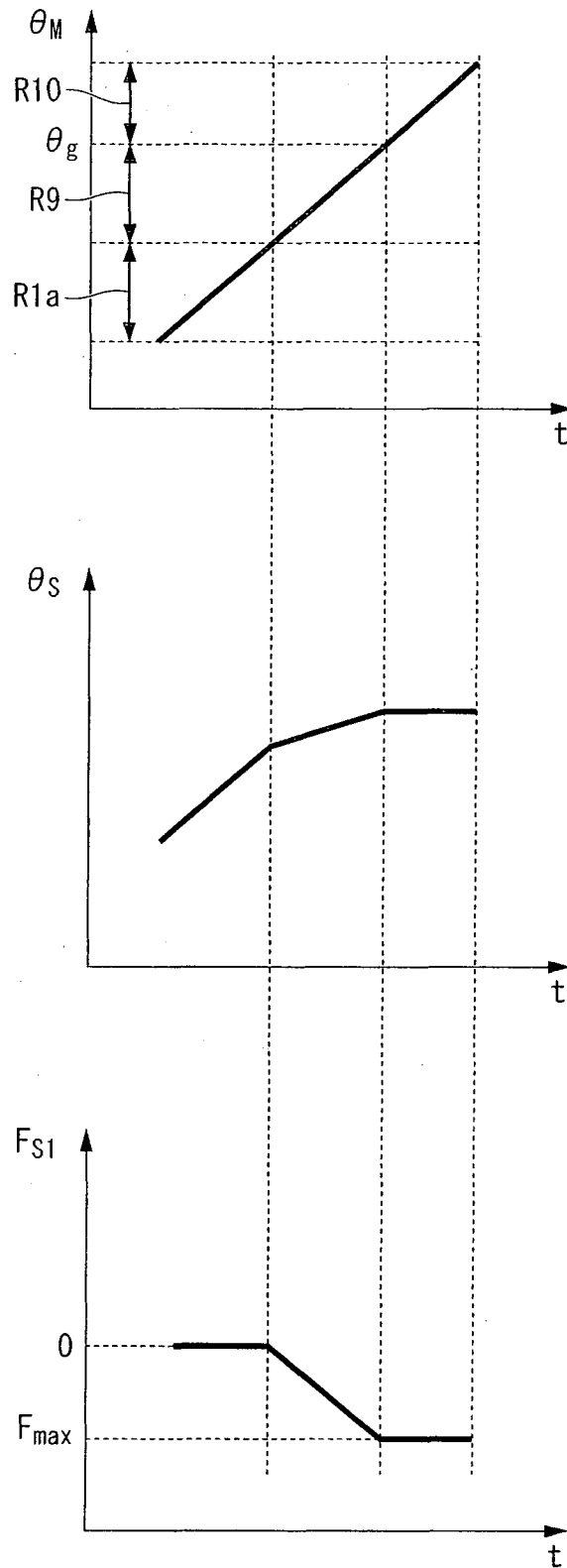
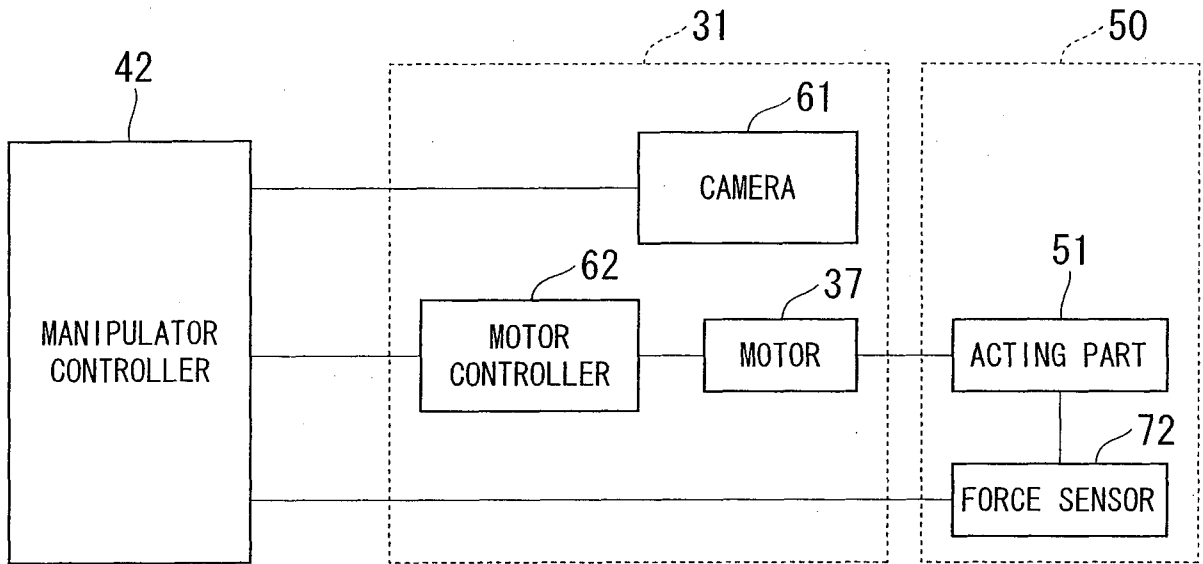

FIG. 15



INTERNATIONAL SEARCH REPORT

International application No.

PCT/JP2012/070576

A. CLASSIFICATION OF SUBJECT MATTER		
Int.Cl. A61B19/00 (2006.01) i, B25J3/00 (2006.01) n		
According to International Patent Classification (IPC) or to both national classification and IPC		
B. FIELDS SEARCHED		
Minimum documentation searched (classification system followed by classification symbols)		
Int.Cl. A61B19/00-19/12, B25J1/00-21/02		
Documentation searched other than minimum documentation to the extent that such documents are included in the fields searched		
Published examined utility model applications of Japan 1922-1996 Published unexamined utility model applications of Japan 1971-2012 Registered utility model specifications of Japan 1996-2012 Published registered utility model applications of Japan 1994-2012		
Electronic data base consulted during the international search (name of data base and, where practicable, search terms used)		
C. DOCUMENTS CONSIDERED TO BE RELEVANT		
Category*	Citation of document, with indication, where appropriate, of the relevant passages	Relevant to claim No.
A	JP 2010-76012 A (TOSHIBA CORP.) 2010.04.08, entire text; all drawings (Family:none)	1-6
A	JP 2006-321027 A (HITACHI LTD.) 2006.11.30, entire text; all drawings & US 2006/0261770 A1 & EP 1724071 A1	1-6
A	WO 2010/109932 A1 (OLYMPUS MEDICAL SYSTEMS CORP.) 2010.09.30, entire text; all drawings & US 2011/0106141 A1 & EP 2305144 A1	1-6
A	JP 2005-511185 A (COMPUTER MOTION INC.) 2005.04.28, entire text; all drawings & WO 2003/049596 A2 & US 2003/0109957 A1	1-6
<input type="checkbox"/> Further documents are listed in the continuation of Box C. <input type="checkbox"/> See patent family annex.		
* Special categories of cited documents: "A" document defining the general state of the art which is not considered to be of particular relevance "E" earlier application or patent but published on or after the international filing date "L" document which may throw doubts on priority claim(s) or which is cited to establish the publication date of another citation or other special reason (as specified) "O" document referring to an oral disclosure, use, exhibition or other means "P" document published prior to the international filing date but later than the priority date claimed "T" later document published after the international filing date or priority date and not in conflict with the application but cited to understand the principle or theory underlying the invention "X" document of particular relevance; the claimed invention cannot be considered novel or cannot be considered to involve an inventive step when the document is taken alone "Y" document of particular relevance; the claimed invention cannot be considered to involve an inventive step when the document is combined with one or more other such documents, such combination being obvious to a person skilled in the art "&" document member of the same patent family		
Date of the actual completion of the international search		Date of mailing of the international search report
31.10.2012		13.11.2012
Name and mailing address of the ISA/JP		Authorized officer
Japan Patent Office		Hirokazu MORIBAYASHI
3-4-3, Kasumigaseki, Chiyoda-ku, Tokyo 100-8915, Japan		31 3025
		Telephone No. +81-3-3581-1101 Ext. 3346

INTERNATIONAL SEARCH REPORT

International application No.

PCT/JP2012/070576

Box No. II Observations where certain claims were found unsearchable (Continuation of item 2 of first sheet)

This international search report has not been established in respect of certain claims under Article 17(2)(a) for the following reasons:

1. Claims Nos.: 7
because they relate to subject matter not required to be searched by this Authority, namely:
The subject matter of claim 7 relates to [a method for treatment of the human or animal body by surgery or therapy], which does not require an international search by the International Searching Authority in accordance with PCT Article 17(2)(a)(i) and [Rule 39.1(iv)].
2. Claims Nos.:
because they relate to parts of the international application that do not comply with the prescribed requirements to such an extent that no meaningful international search can be carried out, specifically:
3. Claims Nos.:
because they are dependent claims and are not drafted in accordance with the second and third sentences of Rule 6.4(a).

Box No. III Observations where unity of invention is lacking (Continuation of item 3 of first sheet)

This International Searching Authority found multiple inventions in this international application, as follows:

1. As all required additional search fees were timely paid by the applicant, this international search report covers all searchable claims.
2. As all searchable claims could be searched without effort justifying additional fees, this Authority did not invite payment of additional fees.
3. As only some of the required additional search fees were timely paid by the applicant, this international search report covers only those claims for which fees were paid, specifically claims Nos.:
4. No required additional search fees were timely paid by the applicant. Consequently, this international search report is restricted to the invention first mentioned in the claims; it is covered by claims Nos.:

Remark on Protest

- The additional search fees were accompanied by the applicant's protest and, where applicable, the payment of a protest fee.
- The additional search fees were accompanied by the applicant's protest but the applicable protest fee was not paid within the time limit specified in the invitation.
- No protest accompanied the payment of additional search fees.