



(51) International Patent Classification:

H04W 72/04 (2009.01) H04W 40/24 (2009.01)
H04W 28/08 (2009.01)

(21) International Application Number:

PCT/EP2019/054127

(22) International Filing Date:

19 February 2019 (19.02.2019)

(25) Filing Language:

English

(26) Publication Language:

English

(71) Applicant: **NOKIA SOLUTIONS AND NETWORKS OY** [FI/FI]; Karakaari 7, 02610 Espoo (FI).

(72) Inventors: **TIIROLA, Esa**; Porttikellonkuja 12, 90450 KEMPELE (FI). **LADDU, Keeth Saliya Jayasinghe**; 68/3/1, Sama Uyana, Kottawa Road, Piliyandala (LK). **KESKITALO, Ilkka**; Varsankuja 3, 90240 Oulu (FI). **KORHONEN, Juha**; Keskiyöntie 12 A, 02210 Espoo (FI).

(74) Agent: **OLIVIER GILDAS MARTINEZ**; PAGE WHITE & FARRER, Bedford House, John Street, London Greater London WC1N 2BF (GB).

(81) Designated States (unless otherwise indicated, for every kind of national protection available): AE, AG, AL, AM, AO, AT, AU, AZ, BA, BB, BG, BH, BN, BR, BW, BY, BZ, CA, CH, CL, CN, CO, CR, CU, CZ, DE, DJ, DK, DM, DO, DZ, EC, EE, EG, ES, FI, GB, GD, GE, GH, GM, GT, HN, HR, HU, ID, IL, IN, IR, IS, JO, JP, KE, KG, KH, KN, KP, KR, KW, KZ, LA, LC, LK, LR, LS, LU, LY, MA, MD, ME, MG, MK, MN, MW, MX, MY, MZ, NA, NG, NI, NO, NZ, OM, PA, PE, PG, PH, PL, PT, QA, RO, RS, RU, RW, SA, SC, SD, SE, SG, SK, SL, SM, ST, SV, SY, TH, TJ, TM, TN, TR, TT, TZ, UA, UG, US, UZ, VC, VN, ZA, ZM, ZW.

(84) Designated States (unless otherwise indicated, for every kind of regional protection available): ARIPO (BW, GH, GM, KE, LR, LS, MW, MZ, NA, RW, SD, SL, ST, SZ, TZ, UG, ZM, ZW), Eurasian (AM, AZ, BY, KG, KZ, RU, TJ, TM), European (AL, AT, BE, BG, CH, CY, CZ, DE, DK, EE, ES, FI, FR, GB, GR, HR, HU, IE, IS, IT, LT, LU, LV, MC, MK, MT, NL, NO, PL, PT, RO, RS, SE, SI, SK, SM,

(54) Title: APPARATUS, METHOD, AND COMPUTER PROGRAM

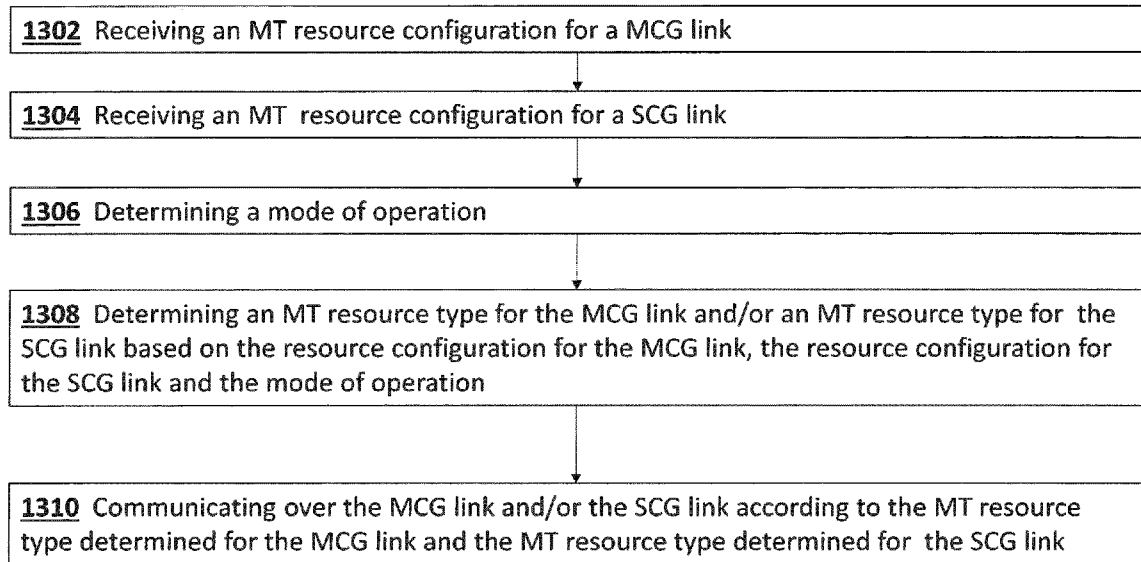

Fig. 13

(57) Abstract: An apparatus comprising: at least one processor; and at least one memory including computer program code; the at least one memory and the computer program code configured to, with the at least one processor, cause the apparatus at least to: receive (1302) a resource configuration for a first cell group link; receive (1304) a resource configuration for a second cell group link; determine (1306) a mode of operation; and determine a resource type for the first cell group link or the second cell group link based on the resource configuration for the first cell group link, the resource configuration for the second cell group link and the mode of operation.



TR), OAPI (BF, BJ, CF, CG, CI, CM, GA, GN, GQ, GW,
KM, ML, MR, NE, SN, TD, TG).

Published:

— *with international search report (Art. 21(3))*

APPARATUS, METHOD, AND COMPUTER PROGRAM

Field of the disclosure

5 The present disclosure relates to an apparatus, a method, and a computer program for communicating over a master cell group link and/or a secondary cell group link by an integrated access and backhaul node.

Background

10

A communication system can be seen as a facility that enables communication sessions between two or more entities such as user terminals, base stations/access points and/or other nodes by providing carriers between the various entities involved in the communications path. A communication system can be provided for example by
15 means of a communication network and one or more compatible communication devices. The communication sessions may comprise, for example, communication of data for carrying communications such as voice, electronic mail (email), text message, multimedia and/or content data and so on. Non-limiting examples of services provided comprise two-way or multi-way calls, data communication or multimedia services and
20 access to a data network system, such as the Internet. In a wireless communication system at least a part of a communication session between at least two stations occurs over a wireless link.

A user can access the communication system by means of an appropriate
25 communication device or terminal. A communication device of a user is often referred to as user equipment (UE) or user device. A communication device is provided with an appropriate signal receiving and transmitting apparatus for enabling communications, for example enabling access to a communication network or communications directly with other users. The communication device may access a
30 carrier provided by a station or access point, and transmit and/or receive communications on the carrier.

The communication system and associated devices typically operate in accordance with a required standard or specification which sets out what the various entities associated with the system are permitted to do and how that should be achieved. Communication protocols and/or parameters which shall be used for the connection are also typically defined. One example of a communications system is UTRAN (3G radio). Another example of an architecture that is known as the long-term evolution (LTE) or the Universal Mobile Telecommunications System (UMTS) radio-access technology. Another example communication system is so called 5G radio or new radio (NR) access technology.

10

Summary

According to an aspect there is provided an apparatus comprising at least one processor and at least one memory including computer code for one or more programs, the at least one memory and the computer code configured, with the at least one processor, to cause the apparatus at least to: receive a resource configuration for a first cell group link; receive a resource configuration for a second cell group link; determine a mode of operation; and determine a resource type for the first cell group link or the second cell group link based on the resource configuration for the first cell group link, the resource configuration for the second cell group link and the mode of operation.

The at least one memory and the computer program code may be configured to, with the at least one processor, cause the apparatus at least to: determine a resource type for the first cell group link and a resource type for the second cell group link based on the resource configuration for the first cell group link, the resource configuration for the second cell group link and the mode of operation.

The resource may be a time domain resource.

30

The resource configuration for the first cell group link may indicate a resource type.

The resource configuration for the second cell group link may indicate a resource type.

The resource type for the first cell group link or the second cell group link may be one of: 'downlink', 'uplink', 'flexible' or 'not available'.

5

The mode of operation may be time division duplexing between the first cell group link and the second cell group link.

10 The at least one memory and the computer program code may be configured to, with the at least one processor, cause the apparatus at least to: determine that the resource configuration for the first cell group link and the resource configuration for the second cell group link form a predefined combination; and determine that the resource type for the first cell group link is 'not available' and the resource type for the second cell group link is 'downlink', 'uplink' or 'flexible'.

15

The predefined combination may be one of: the resource configuration for the first cell group link is 'flexible' and the resource configuration for the second cell group link is 'downlink'; or the resource configuration for the first cell group link is 'flexible' and the resource configuration for the second cell group link is 'uplink'.

20

The resource type for the second cell group link may be 'downlink' or 'uplink' based on the resource configuration of the second cell group link.

25 The at least one memory and the computer program code may be configured to, with the at least one processor, cause the apparatus at least to: determine that the resource configuration for the first cell group link and the resource configuration for the second cell group link form a predefined combination; and determine that the resource type for the first cell group link is 'downlink', 'uplink' or 'flexible' and the resource type for the second cell group link is 'resource not available'.

30

The predefined combination may be one of: the resource configuration for the first cell group link is 'downlink' and the resource configuration for the second cell group link is

'flexible'; or the resource configuration for the first cell group link is 'uplink' and the resource configuration for the second cell group link is 'flexible'.

5 The resource type for the first cell group link may be 'downlink' or 'uplink' based on the resource configuration of the first cell group link.

The mode of operation may be spatial division duplexing or frequency division duplexing between the first cell group link and the second cell group link.

10 The at least one memory and the computer program code may be configured to, with the at least one processor, cause the apparatus at least to: determine that the resource configuration for the first cell group link and the resource configuration for the second cell group link form a predefined combination; and determine that the resource type for the first cell group link is 'downlink', 'uplink' or 'flexible' and the resource type for
15 the second cell group link is 'not available'.

The predefined combination may be one of: the resource configuration for the first cell group link is 'downlink' and the resource configuration for the second cell group link is 'flexible'; or the resource configuration for the first cell group link is 'uplink' and the
20 resource configuration for the second cell group link is 'flexible'.

The resource type for the first cell group link may be 'downlink' or 'uplink' based on the resource configuration of the first cell group link.

25 The at least one memory and the computer program code may be configured to, with the at least one processor, cause the apparatus at least to: determine that the resource configuration for the first cell group link and the resource configuration for the second cell group link form a predefined combination; and determine that the resource type for the first cell group link is 'downlink', 'uplink' or 'flexible' and the resource type for
30 the second cell group link is 'available'.

The predefined combination may be one of: the resource configuration for the first cell group link is 'downlink' and the resource configuration for the second cell group link is 'downlink'; or the resource configuration for the first cell group link is 'uplink' and the resource configuration for the second cell group link is 'uplink'.

5

The resource type for the first cell group link may be 'downlink' or 'uplink' based on the resource configuration of the first cell group link and the resource type for the second cell group link may be 'downlink' or 'uplink' based on the resource configuration of the second cell group link.

10

The time domain resource may comprise a first frequency domain resource for the first cell group link and a second frequency domain resource for the second cell group link.

At least one of the resource configuration for the first cell group link and the resource configuration for the second cell group link may be a semi-static configuration.

The at least one memory and the computer program code may be configured to, with the at least one processor, cause the apparatus at least to: adjust the at least one of the resource type for the first cell group link and the resource type for the second cell group link based on a dynamic downlink control information.

One of the resource configuration for the first cell group link and the resource configuration for the second cell group link may be a semi-static configuration and the other one of the resource configuration for the first cell group link and the resource configuration for the second cell group link may be a dynamic configuration.

The apparatus may be an integrated access and backhaul node.

The apparatus may comprise a single mobile terminal part providing dual connectivity to two integrated access and backhaul parent nodes, wherein the first cell link is a master cell link and the second cell link is a secondary cell link; or two mobile terminal parts each providing single connectivity to a respective integrated access and

backhaul parent node, wherein the first cell link is a master cell link and the second cell link is another master cell link.

The mode of operation may be determined based on an indication received from an integrated access and backhaul parent node or a centralized unit.

According to an aspect there is provided an apparatus comprising circuitry configured to: receive a resource configuration for a first cell group link; receive a resource configuration for a second cell group link; determine a mode of operation; and determine a resource type for the first cell group link or the second cell group link based on the resource configuration for the first cell group link, the resource configuration for the second cell group link and the mode of operation.

The circuitry may be configured to: determine a resource type for the first cell group link and a resource type for the second cell group link based on the resource configuration for the first cell group link, the resource configuration for the second cell group link and the mode of operation.

The resource may be a time domain resource.

The resource configuration for the first cell group link may indicate a resource type.

The resource configuration for the second cell group link may indicate a resource type.

The resource type for the first cell group link or the second cell group link may be one of: 'downlink', 'uplink', 'flexible' or 'not available'.

The mode of operation may be time division duplexing between the first cell group link and the second cell group link.

The circuitry may be configured to: determine that the resource configuration for the first cell group link and the resource configuration for the second cell group link form

a predefined combination; and determine that the resource type for the first cell group link is 'not available' and the resource type for the second cell group link is 'downlink', 'uplink' or 'flexible'.

- 5 The predefined combination may be one of: the resource configuration for the first cell group link is 'flexible' and the resource configuration for the second cell group link is 'downlink; or the resource configuration for the first cell group link is 'flexible' and the resource configuration for the second cell group link is 'uplink'.
- 10 The resource type for the second cell group link may be 'downlink' or 'uplink' based on the resource configuration of the second cell group link.

The circuitry may be configured to: determine that the resource configuration for the first cell group link and the resource configuration for the second cell group link form
15 a predefined combination; and determine that the resource type for the first cell group link is 'downlink', 'uplink' or 'flexible' and the resource type for the second cell group link is 'resource not available'.

The predefined combination may be one of: the resource configuration for the first cell
20 group link is 'downlink' and the resource configuration for the second cell group link is 'flexible'; or the resource configuration for the first cell group link is 'uplink' and the resource configuration for the second cell group link is 'flexible'.

The resource type for the first cell group link may be 'downlink' or 'uplink' based on the
25 resource configuration of the first cell group link.

The mode of operation may be spatial division duplexing or frequency division duplexing between the first cell group link and the second cell group link.

30 The circuitry may be configured to: determine that the resource configuration for the first cell group link and the resource configuration for the second cell group link form a predefined combination; and determine that the resource type for the first cell group

link is 'downlink', 'uplink' or 'flexible' and the resource type for the second cell group link is 'not available'.

The predefined combination may be one of: the resource configuration for the first cell group link is 'downlink' and the resource configuration for the second cell group link is 'flexible'; or the resource configuration for the first cell group link is 'uplink' and the resource configuration for the second cell group link is 'flexible'.

The resource type for the first cell group link may be 'downlink' or 'uplink' based on the resource configuration of the first cell group link.

The circuitry may be configured to: determine that the resource configuration for the first cell group link and the resource configuration for the second cell group link form a predefined combination; and determine that the resource type for the first cell group link is 'downlink', 'uplink' or 'flexible' and the resource type for the second cell group link is 'available'.

The predefined combination may be one of: the resource configuration for the first cell group link is 'downlink' and the resource configuration for the second cell group link is 'downlink'; or the resource configuration for the first cell group link is 'uplink' and the resource configuration for the second cell group link is 'uplink'.

The resource type for the first cell group link may be 'downlink' or 'uplink' based on the resource configuration of the first cell group link and the resource type for the second cell group link may be 'downlink' or 'uplink' based on the resource configuration of the second cell group link.

The time domain resource may comprise a first frequency domain resource for the first cell group link and a second frequency domain resource for the second cell group link.

At least one of the resource configuration for the first cell group link and the resource configuration for the second cell group link may be a semi-static configuration.

The circuitry may be configured to: adjust the at least one of the resource type for the first cell group link and the resource type for the second cell group link based on a dynamic downlink control information.

5

One of the resource configuration for the first cell group link and the resource configuration for the second cell group link may be a semi-static configuration and the other one of the resource configuration for the first cell group link and the resource configuration for the second cell group link may be a dynamic configuration.

10

The apparatus may be an integrated access and backhaul node.

The apparatus may comprise a single mobile terminal part providing dual connectivity to two integrated access and backhaul parent nodes, wherein the first cell link is a master cell link and the second cell link is a secondary cell link; or two mobile terminal parts each providing single connectivity to a respective integrated access and backhaul parent node, wherein the first cell link is a master cell link and the second cell link is another master cell link.

15

The mode of operation may be determined based on an indication received from an integrated access and backhaul parent node or a centralized unit.

20

According to an aspect there is provided an apparatus comprising means for: receiving a resource configuration for a first cell group link; receiving a resource configuration for a second cell group link; determining a mode of operation; and determining a resource type for the first cell group link or the second cell group link based on the resource configuration for the first cell group link, the resource configuration for the second cell group link and the mode of operation.

25

The apparatus may comprise means for: determining a resource type for the first cell group link and a resource type for the second cell group link based on the resource

30

configuration for the first cell group link, the resource configuration for the second cell group link and the mode of operation.

The resource may be a time domain resource.

5

The resource configuration for the first cell group link may indicate a resource type.

The resource configuration for the second cell group link may indicate a resource type.

10 The resource type for the first cell group link or the second cell group link may be one of: 'downlink', 'uplink', 'flexible' or 'not available'.

The mode of operation may be time division duplexing between the first cell group link and the second cell group link.

15

The apparatus may comprise means for: determining that the resource configuration for the first cell group link and the resource configuration for the second cell group link form a predefined combination; and determining that the resource type for the first cell group link is 'not available' and the resource type for the second cell group link is
20 'downlink', 'uplink' or 'flexible'.

The predefined combination may be one of: the resource configuration for the first cell group link is 'flexible' and the resource configuration for the second cell group link is 'downlink; or the resource configuration for the first cell group link is 'flexible' and the
25 resource configuration for the second cell group link is 'uplink'.

The resource type for the second cell group link may be 'downlink' or 'uplink' based on the resource configuration of the second cell group link.

30 The apparatus may comprise means for: determining that the resource configuration for the first cell group link and the resource configuration for the second cell group link form a predefined combination; and determining that the resource type for the first cell

group link is 'downlink', 'uplink' or 'flexible' and the resource type for the second cell group link is 'resource not available'.

5 The predefined combination may be one of: the resource configuration for the first cell group link is 'downlink' and the resource configuration for the second cell group link is 'flexible'; or the resource configuration for the first cell group link is 'uplink' and the resource configuration for the second cell group link is 'flexible'.

10 The resource type for the first cell group link may be 'downlink' or 'uplink' based on the resource configuration of the first cell group link.

The mode of operation may be spatial division duplexing or frequency division duplexing between the first cell group link and the second cell group link.

15 The apparatus may comprise means for: determining that the resource configuration for the first cell group link and the resource configuration for the second cell group link form a predefined combination; and determining that the resource type for the first cell group link is 'downlink', 'uplink' or 'flexible' and the resource type for the second cell group link is 'not available'.

20

The predefined combination may be one of: the resource configuration for the first cell group link is 'downlink' and the resource configuration for the second cell group link is 'flexible'; or the resource configuration for the first cell group link is 'uplink' and the resource configuration for the second cell group link is 'flexible'.

25

The resource type for the first cell group link may be 'downlink' or 'uplink' based on the resource configuration of the first cell group link.

30 The apparatus may comprise means for: determining that the resource configuration for the first cell group link and the resource configuration for the second cell group link form a predefined combination; and determining that the resource type for the first cell

group link is 'downlink', 'uplink' or 'flexible' and the resource type for the second cell group link is 'available'.

5 The predefined combination may be one of: the resource configuration for the first cell group link is 'downlink and the resource configuration for the second cell group link is 'downlink'; or the resource configuration for the first cell group link is 'uplink' and the resource configuration for the second cell group link is 'uplink'.

10 The resource type for the first cell group link may be 'downlink' or 'uplink' based on the resource configuration of the first cell group link and the resource type for the second cell group link may be 'downlink' or 'uplink' based on the resource configuration of the second cell group link.

15 The time domain resource may comprise a first frequency domain resource for the first cell group link and a second frequency domain resource for the second cell group link.

At least one of the resource configuration for the first cell group link and the resource configuration for the second cell group link may be a semi-static configuration.

20 The apparatus may comprise means for: adjusting the at least one of the resource type for the first cell group link and the resource type for the second cell group link based on a dynamic downlink control information.

25 One of the resource configuration for the first cell group link and the resource configuration for the second cell group link may be a semi-static configuration and the other one of the resource configuration for the first cell group link and the resource configuration for the second cell group link may be a dynamic configuration.

The apparatus may be an integrated access and backhaul node.

30

The apparatus may comprise a single mobile terminal part providing dual connectivity to two integrated access and backhaul parent nodes, wherein the first cell link is a

master cell link and the second cell link is a secondary cell link; or two mobile terminal parts each providing single connectivity to a respective integrated access and backhaul parent node, wherein the first cell link is a master cell link and the second cell link is another master cell link.

5

The mode of operation may be determined based on an indication received from an integrated access and backhaul parent node or a centralized unit.

According to an aspect there is provided a method comprising: receiving a resource configuration for a first cell group link; receiving a resource configuration for a second cell group link; determining a mode of operation; and determining a resource type for the first cell group link or the second cell group link based on the resource configuration for the first cell group link, the resource configuration for the second cell group link and the mode of operation.

15

The method may comprise: determining a resource type for the first cell group link and a resource type for the second cell group link based on the resource configuration for the first cell group link, the resource configuration for the second cell group link and the mode of operation.

20

The resource may be a time domain resource.

The resource configuration for the first cell group link may indicate a resource type.

25 The resource configuration for the second cell group link may indicate a resource type.

The resource type for the first cell group link or the second cell group link may be one of: 'downlink', 'uplink', 'flexible' or 'not available'.

30 The mode of operation may be time division duplexing between the first cell group link and the second cell group link.

The method may comprise: determining that the resource configuration for the first cell group link and the resource configuration for the second cell group link form a predefined combination; and determining that the resource type for the first cell group link is 'not available' and the resource type for the second cell group link is 'downlink',
5 'uplink' or 'flexible'.

The predefined combination may be one of: the resource configuration for the first cell group link is 'flexible' and the resource configuration for the second cell group link is 'downlink'; or the resource configuration for the first cell group link is 'flexible' and the
10 resource configuration for the second cell group link is 'uplink'.

The resource type for the second cell group link may be 'downlink' or 'uplink' based on the resource configuration of the second cell group link.

15 The method may comprise:: determining that the resource configuration for the first cell group link and the resource configuration for the second cell group link form a predefined combination; and determining that the resource type for the first cell group link is 'downlink', 'uplink' or 'flexible' and the resource type for the second cell group link is 'resource not available'.

20 The predefined combination may be one of: the resource configuration for the first cell group link is 'downlink' and the resource configuration for the second cell group link is 'flexible'; or the resource configuration for the first cell group link is 'uplink' and the resource configuration for the second cell group link is 'flexible'.

25 The resource type for the first cell group link may be 'downlink' or 'uplink' based on the resource configuration of the first cell group link.

30 The mode of operation may be spatial division duplexing or frequency division duplexing between the first cell group link and the second cell group link.

The method may comprise: determining that the resource configuration for the first cell group link and the resource configuration for the second cell group link form a predefined combination; and determining that the resource type for the first cell group link is 'downlink', 'uplink' or 'flexible' and the resource type for the second cell group link is 'not available'.

The predefined combination may be one of: the resource configuration for the first cell group link is 'downlink' and the resource configuration for the second cell group link is 'flexible'; or the resource configuration for the first cell group link is 'uplink' and the resource configuration for the second cell group link is 'flexible'.

The resource type for the first cell group link may be 'downlink' or 'uplink' based on the resource configuration of the first cell group link.

The method may comprise: determining that the resource configuration for the first cell group link and the resource configuration for the second cell group link form a predefined combination; and determining that the resource type for the first cell group link is 'downlink', 'uplink' or 'flexible' and the resource type for the second cell group link is 'available'.

The predefined combination may be one of: the resource configuration for the first cell group link is 'downlink' and the resource configuration for the second cell group link is 'downlink'; or the resource configuration for the first cell group link is 'uplink' and the resource configuration for the second cell group link is 'uplink'.

The resource type for the first cell group link may be 'downlink' or 'uplink' based on the resource configuration of the first cell group link and the resource type for the second cell group link may be 'downlink' or 'uplink' based on the resource configuration of the second cell group link.

The time domain resource may comprise a first frequency domain resource for the first cell group link and a second frequency domain resource for the second cell group link.

At least one of the resource configuration for the first cell group link and the resource configuration for the second cell group link may be a semi-static configuration.

- 5 The method may comprise: adjusting the at least one of the resource type for the first cell group link and the resource type for the second cell group link based on a dynamic downlink control information.

10 One of the resource configuration for the first cell group link and the resource configuration for the second cell group link may be a semi-static configuration and the other one of the resource configuration for the first cell group link and the resource configuration for the second cell group link may be a dynamic configuration.

The method may be performed by an integrated access and backhaul node.

15

The method may be performed by an apparatus comprising a single mobile terminal part providing dual connectivity to two integrated access and backhaul parent nodes, wherein the first cell link is a master cell link and the second cell link is a secondary cell link; or two mobile terminal parts each providing single connectivity to a respective
20 integrated access and backhaul parent node, wherein the first cell link is a master cell link and the second cell link is another master cell link.

The mode of operation may be determined based on an indication received from an integrated access and backhaul parent node or a centralized unit.

25

According to an aspect there is provided a computer program comprising computer executable code which when run on at least one processor is configured to: receive a resource configuration for a first cell group link; receive a resource configuration for a second cell group link; determine a mode of operation; and determine a resource type
30 for the first cell group link or the second cell group link based on the resource configuration for the first cell group link, the resource configuration for the second cell group link and the mode of operation.

The computer program may comprise computer executable code which when run on at least one processor is configured to: determine a resource type for the first cell group link and a resource type for the second cell group link based on the resource configuration for the first cell group link, the resource configuration for the second cell group link and the mode of operation.

The resource may be a time domain resource.

The resource configuration for the first cell group link may indicate a resource type.

The resource configuration for the second cell group link may indicate a resource type.

The resource type for the first cell group link or the second cell group link may be one of: 'downlink', 'uplink', 'flexible' or 'not available'.

The mode of operation may be time division duplexing between the first cell group link and the second cell group link.

The computer program may comprise computer executable code which when run on at least one processor is configured to: determine that the resource configuration for the first cell group link and the resource configuration for the second cell group link form a predefined combination; and determine that the resource type for the first cell group link is 'not available' and the resource type for the second cell group link is 'downlink', 'uplink' or 'flexible'.

The predefined combination may be one of: the resource configuration for the first cell group link is 'flexible' and the resource configuration for the second cell group link is 'downlink; or the resource configuration for the first cell group link is 'flexible' and the resource configuration for the second cell group link is 'uplink'.

The resource type for the second cell group link may be 'downlink' or 'uplink' based on the resource configuration of the second cell group link.

5 The computer program may comprise computer executable code which when run on at least one processor is configured to: determine that the resource configuration for the first cell group link and the resource configuration for the second cell group link form a predefined combination; and determine that the resource type for the first cell group link is 'downlink', 'uplink' or 'flexible' and the resource type for the second cell group link is 'resource not available'.

10

The predefined combination may be one of: the resource configuration for the first cell group link is 'downlink' and the resource configuration for the second cell group link is 'flexible'; or the resource configuration for the first cell group link is 'uplink' and the resource configuration for the second cell group link is 'flexible'.

15

The resource type for the first cell group link may be 'downlink' or 'uplink' based on the resource configuration of the first cell group link.

20 The mode of operation may be spatial division duplexing or frequency division duplexing between the first cell group link and the second cell group link.

25 The computer program may comprise computer executable code which when run on at least one processor is configured to: determine that the resource configuration for the first cell group link and the resource configuration for the second cell group link form a predefined combination; and determine that the resource type for the first cell group link is 'downlink', 'uplink' or 'flexible' and the resource type for the second cell group link is 'not available'.

30 The predefined combination may be one of: the resource configuration for the first cell group link is 'downlink' and the resource configuration for the second cell group link is 'flexible'; or the resource configuration for the first cell group link is 'uplink' and the resource configuration for the second cell group link is 'flexible'.

The resource type for the first cell group link may be 'downlink' or 'uplink' based on the resource configuration of the first cell group link.

- 5 The computer program may comprise computer executable code which when run on at least one processor is configured to: determine that the resource configuration for the first cell group link and the resource configuration for the second cell group link form a predefined combination; and determine that the resource type for the first cell group link is 'downlink', 'uplink' or 'flexible' and the resource type for the second cell group link is 'available'.
- 10

The predefined combination may be one of: the resource configuration for the first cell group link is 'downlink' and the resource configuration for the second cell group link is 'downlink'; or the resource configuration for the first cell group link is 'uplink' and the resource configuration for the second cell group link is 'uplink'.

15

The resource type for the first cell group link may be 'downlink' or 'uplink' based on the resource configuration of the first cell group link and the resource type for the second cell group link may be 'downlink' or 'uplink' based on the resource configuration of the second cell group link.

20

The time domain resource may comprise a first frequency domain resource for the first cell group link and a second frequency domain resource for the second cell group link.

- 25 At least one of the resource configuration for the first cell group link and the resource configuration for the second cell group link may be a semi-static configuration.

The computer program may comprise computer executable code which when run on at least one processor is configured to: adjust the at least one of the resource type for the first cell group link and the resource type for the second cell group link based on a dynamic downlink control information.

30

One of the resource configuration for the first cell group link and the resource configuration for the second cell group link may be a semi-static configuration and the other one of the resource configuration for the first cell group link and the resource configuration for the second cell group link may be a dynamic configuration.

5

The mode of operation may be determined based on an indication received from an integrated access and backhaul parent node or a centralized unit.

According to an aspect, there is provided a computer readable medium comprising program instructions stored thereon for performing at least one of the above methods.

10

According to an aspect, there is provided a non-transitory computer readable medium comprising program instructions stored thereon for performing at least one of the above methods.

15

According to an aspect, there is provided a non-volatile tangible memory medium comprising program instructions stored thereon for performing at least one of the above methods.

In the above, many different aspects have been described. It should be appreciated that further aspects may be provided by the combination of any two or more of the aspects described above.

20

Various other aspects are also described in the following detailed description and in the attached claims.

25

List of abbreviations

AF:	Application Function
30 AUSF:	Authentication Server Function
AMF:	Access Management Function
BH:	Backhaul

	CP:	Control Plane
	CU:	Centralized Unit
	DC:	Dual Connectivity
	DCI:	Downlink Control Information
5	DL:	Downlink
	DU:	Distributed Unit
	FDM:	Frequency Division Multiplexing
	F:	Flexible
	GNB:	gNodeB
10	GPRS:	General Packet Radio Services
	GSM:	Global System for Mobile communication
	GTP:	GPRS Tunnelling Protocol
	IAB:	Integrated Access and Backhaul
	IP:	Internet Protocol
15	LTE:	Long Term Evolution
	L1:	Layer 1
	L2:	Layer 2
	NEF:	Network Exposure Function
	NR:	New Radio
20	MAC:	Medium Access Control
	MCG:	Master Cell Group
	MN:	Master Node
	MS:	Mobile Station
	MT:	Mobile Terminal
25	MTC:	Machine Type Communication
	NA:	Not Available
	NR:	New Radio
	NG:	Next Generation
	NGC:	Next Generation Core Network
30	PDCCP:	Packet Data Convergence Protocol
	PHY:	Physical
	RAM:	Random Access Memory

	RAN:	Radio Access Network
	RLC:	Radio Link Control
	RLF:	Radio Link Failure
	ROM:	Read Only Memory
5	RRC:	Radio Resource Control
	SC:	Single Connectivity
	SCG:	Secondary Cell Group
	SDM:	Space Division Multiplexing
	SMF:	Session Management Function
10	SN:	Secondary Node
	TDD:	Time Division Duplex
	TDM:	Time Division Multiplexing
	UDM:	User Data Management
	UDP:	User Data Protocol
15	UE:	User Equipment
	UL:	Uplink
	UMTS:	Universal Mobile Telecommunication System
	UP:	User Plane
	UPF:	User Plane Function
20	USB:	Universal Serial Bus
	WI:	Work Item
	WID:	Work Item Description
	3GPP:	3 rd Generation Partnership Project
	5G:	5 th Generation
25	5GC:	5G Core network
	5GS:	5G System
	-U:	User plane
	-C:	Control plane

Brief Description of the Figures

Embodiments will now be described, by way of example only, with reference to the accompanying Figures in which:

5 Figure 1 shows a schematic representation of a 5G system;

Figure 2 shows a schematic representation of a control apparatus;

Figure 3 shows a schematic representation of a terminal;

10

Figure 4 shows a schematic representation of an integrated access and backhaul node connected to an integrated access and backhaul donor node through another integrated access and backhaul node;

15 Figure 5a shows a schematic representation of an integrated access and backhaul node connected to an integrated access and backhaul donor node in a single connectivity scenario;

20 Figure 5b shows a schematic representation of an integrated access and backhaul node connected to integrated access and backhaul donor node in a dual connectivity scenario;

25 Figure 6 shows a schematic representation of an integrated access and backhaul node connected to an integrated access and backhaul parent node and an integrated access and backhaul child node;

30 Figure 7 shows a schematic representation of an integrated access and backhaul node connected to integrated access and backhaul parent nodes and an integrated access and backhaul child node in a dual connectivity scenario;

30

Figure 8 shows a table for enabling an integrated access and backhaul node to determine a resource type for a master cell group link and/or a secondary cell group

link when the master cell group link and the secondary cell group link are time division multiplexed;

5 Figure 9 shows a table for enabling an integrated access and backhaul node to determine a resource type for a master cell group link and/or a secondary cell group link when the master cell group link and the secondary cell group link are space division multiplexed or frequency division multiplexed;

10 Figure 10 shows an alternative table for enabling an integrated access and backhaul node to determine a resource type for a master cell group link and/or a secondary cell group link when the master cell group link and the secondary cell group link are space division multiplexed or frequency division multiplexed;

15 Figure 11 shows a block diagram of a method for enabling an integrated access and backhaul node to determine a resource type for a master cell group link and/or a secondary cell group link when the master cell group link and the secondary cell group link are time division multiplexed;

20 Figure 12 shows a block diagram of a method for enabling an integrated access and backhaul node to determine a resource type for a master cell group link and/or a secondary cell group link when the master cell group link and the secondary cell group link are space division multiplexed or frequency division multiplexed;

25 Figure 13 shows a block diagram of a method for communicating over a master cell group link and a secondary cell group link in a dual connectivity scenario; and

Figure 14 shows a block diagram of a method for communicating over a master cell group link and another master cell group link in a double single connectivity scenario; and

30

Figure 15 shows a schematic representation of a non-volatile memory medium storing instructions which when executed by a processor allow a processor to implement one or more of the aspects of any of Figures 1 and 14.

5 Detailed Description of the Figures

In the following certain embodiments are explained with reference to mobile communication devices capable of communication via a wireless cellular system and mobile communication systems serving such mobile communication devices. Before explaining in detail the exemplifying embodiments, certain general principles of a wireless communication system, access systems thereof, and mobile communication devices are briefly explained with reference to Figures 1 to 3 to assist in understanding the technology underlying the described examples.

Figure 1 shows a schematic representation of a 5G system (5GS). The 5GS may comprise a terminal, a 5G radio access network (5G RAN), a 5G core network (5GC), one or more application function (AF) and one or more data networks (DN).

The 5G RAN may comprise one or more gNodeB (GNB) distributed unit (DU) functions connected to one or more gNodeB (GNB) centralized unit (CU) functions.

The 5GC may comprise an access management function (AMF), a session management function (SMF), an authentication server function (AUSF), a user data management (UDM), a user plane function (UPF) and/or a network exposure function (NEF).

Figure 2 illustrates an example of a control apparatus 200 for controlling a function, such as a function of the 5G RAN or the 5GC as illustrated on Figure 1. The control apparatus may comprise at least one random access memory (RAM) 211a, at least one read only memory (ROM) 211b, at least one processor 212, 213 and an input/output interface 214. The at least one processor 212, 213 may be coupled to the RAM 211a and the ROM 211b. Via the input/output interface 214 may be coupled to other components of the function of the 5G RAN or the 5GC. The at least one processor

212, 213 may be configured to execute an appropriate software code 215. The software code 215 may for example allow to perform one or more steps to perform one or more of the following aspects. The software code 215 may be stored in the ROM 211b. The control apparatus 200 may be interconnected with another control apparatus 200 controlling another function of the 5G RAN or of the 5GC. In some 5 embodiments, each function of the 5G RAN or the 5GC comprises a control apparatus 200. In alternative embodiments, two or more function of the 5G RAN or the 5GC may share a control apparatus.

10 Figure 3 illustrates an example of a terminal 300, such as the terminal illustrated on Figure 1. The terminal 300 may be provided by any device capable of sending and receiving radio signals. Non-limiting examples comprise a user equipment, a mobile station (MS) or mobile device such as a mobile phone or what is known as a 'smart phone', a computer provided with a wireless interface card or other wireless interface 15 facility (e.g., USB dongle), a personal data assistant (PDA) or a tablet provided with wireless communication capabilities, a machine-type communications (MTC) device, an Internet of things (IoT) type communication device or any combinations of these or the like. The terminal 300 may provide, for example, communication of data for carrying communications. The communications may be one or more of voice, 20 electronic mail (email), text message, multimedia, data, machine data and so on.

The terminal 300 may receive signals over an air or radio interface 307 via appropriate apparatus for receiving and may transmit signals via appropriate apparatus for transmitting radio signals. In Figure 3 transceiver apparatus is designated 25 schematically by block 306. The transceiver apparatus 306 may be provided for example by means of a radio part and associated antenna arrangement. The antenna arrangement may be arranged internally or externally to the mobile device.

The terminal 300 may be provided with at least one processor 301, at least one 30 memory ROM 302a, at least one RAM 302b and other possible components 303 for use in software and hardware aided execution of tasks it is designed to perform, including control of access to and communications with access systems and other

communication devices. The at least one processor 301 is coupled to the RAM 211a and the ROM 211b. The at least one processor 301 may be configured to execute an appropriate software code 308. The software code 308 may for example allow to perform one or more of the following aspects. The software code 308 may be stored
5 in the ROM 211b.

The processor, storage and other relevant control apparatus can be provided on an appropriate circuit board and/or in chipsets. This feature is denoted by reference 304. The device may optionally have a user interface such as key pad 305, touch sensitive
10 screen or pad, combinations thereof or the like. Optionally one or more of a display, a speaker and a microphone may be provided depending on the type of the device.

One or more of the following aspects relate to integrated access and backhaul (IAB). More specifically, one or more of the following aspects relate to resource type
15 determination in the case of IAB node in dual connectivity (DC) with an IAB parent node via a master cell group (MCG) link and another IAB parent node via a secondary cell group (SCG) link.

3GPP study item related to IAB (RP-172290, "Study on Integrated Access and
20 Backhaul for NR", AT&T, Qualcomm, Samsung) was finalized and the study item outcome was captured in TR 38.874. In RAN #82 meeting, IAB work item was approved in RP-182882 and it is expected to discuss multi-connectivity to support the route redundancy and route selection. The exact text in the work item description (WID) is as follows:

25

"Specification of IAB-node migration underneath the same IAB-donor (with or without a change of IAB-donor [distributed unit (DU)], and between different IAB-donors. Migration of IAB-node could be network-controlled or could be due to [backhaul (BH)] [radio link failure (RLF)]."

30

Support for route redundancy and route selection based on multi-connectivity (e.g. TR 38.874 clause 9.7), leveraging existing NR solutions as well as NR-NR DC, without additional RAN1 work. (see NOTE1)".

- 5 The objectives related to the radio resource allocation under responsibility of RAN1 were defined as follows:

"Specification of mechanisms for resource multiplexing among backhaul and access links. This includes:

10

- *Specification of semi-static configuration for IAB-node/IAB-donor DU resources in case of TDM operation subject to half-duplex constraint. This shall be forward compatible to allow the support of half-duplex scenarios with [frequency division multiplexing (FDM)] and [space division multiplexing (SDM)] resource sharing among backhaul and access links.*

15

- *Specification of time resource types for the DU's child links: [downlink (DL)] hard, DL soft, [uplink (UL)] hard, UL soft, Flexible hard, Flexible soft, Not Available.*

20

- *Specification of dynamic indication (L1 signalling) of the availability of soft resources for a child IAB-node DU.*

25

- *Specification of required transmission/reception rules for IAB-nodes and associated behaviours regarding time resource utilization as discussed in TR 38.874 clause 7.3.3".*

30

NR may allow network deployment with minimized manual efforts and/or as automated self-configuration as possible. Especially on higher frequency bands the coverage may be problematic and specific capabilities may be needed for NR to enable effortless coverage extensions with minimized (or no) requirements for network (re-)planning in a fast and cost-effective manner. For these reasons, 3GPP is specifying an IAB

solution with capabilities enabling wireless backhauling for NR sites that do not have fixed (e.g. wired or fibre) connection to the core network. Using radio connection for backhauling may eliminate the need for cabling of all sites (which can be very dense) which may dramatically reduce the initial deployment costs.

5

Furthermore, an intention may be to use the same carrier for both backhaul and access links sharing the same radio resources and, in some cases, also radio transceivers. Frequency bands especially applicable for IAB may be those having sufficient capacity (i.e. large enough carrier bandwidths). These carriers may be on mmWave bands
10 which typically are unpaired time division duplexing (TDD) bands (a.k.a. unpaired bands). Therefore, the IAB may consider a half-duplex constraint (i.e. no simultaneous transmission and reception to avoid excessive interference between transmitter and receiver).

15 Yet another requirement for IAB may be the support for multi-hop relaying where an IAB node may provide wireless BH link for the next hop IAB node. The serving IAB node providing the BH connection may be called an IAB parent node. An IAB parent node may either be an IAB donor node (with wired connection to the core network) or another IAB node. The served IAB node may be called a child IAB node. In DC
20 scenario there may be two IAB parent nodes. An IAB parent node may be a master node (MN). Another IAB parent node may be a secondary node (SN).

There are different options for the IAB architecture. Figure 4 shows a high-level architecture for layer 2 (L2) relaying with distributed base station, i.e. gNB, architecture
25 which has been adopted as the basis for normative work in the IAB Work Item (WI)RP-182882.

The architecture comprises an IAB donor node and IAB nodes. The IAB donor node may comprise a CU part and a DU part. The IAB nodes may comprise a DU part and
30 a mobile terminal (MT) part. Via the MT part, the IAB nodes may connect to an upstream IAB node or the IAB donor node. Via the DU part, the IAB nodes may connect to UEs and to MT parts of downstream IAB nodes.

The IAB donor node may host the CU for all IAB nodes. That is, the IAB donor node may run radio resource control (RRC), higher L2 (e.g. packet data convergence (PDCP)) and/or control functions for the subtending IAB topology. DUs may reside at the IAB nodes hosting the lower L2 protocol layers (RLC, MAC) and the physical (PHY) layer. The CU may have two control interfaces to the IAB nodes, namely RRC connection to the IAB-MT and F1-C to the IAB-DU. Hence both RRC signalling and F1-AP may be available for the IAB configuration and control. With this architecture the radio resources usage may have central coordination by the donor CU.

10

TR 38.874 (clause 7.3.3) refers to resource coordination as follows:

“From an IAB-node MT point-of-view, as in Rel. 15, the following time-domain resources can be indicated for the parent link:

- 15
- *Downlink time resource;*
 - *Uplink time resource;*
 - *Flexible time resource.*

From an IAB-node DU point-of-view, the child link has the following types of time resources:

- 20
- *Downlink time resource;*
 - *Uplink time resource;*
 - *Flexible time resource;*
 - *Not available time resources (resources not to be used for communication on the DU child links).*

25 *Each of the downlink, uplink and flexible time-resource types of the DU child link can belong to one of two categories:*

- *Hard: The corresponding time resource is always available for the DU child link;*

- *Soft: The availability of the corresponding time resource for the DU child link is explicitly and/or implicitly controlled by the parent node.*

[...]

In order to support mechanisms for resource allocation for IAB-nodes, semi-static configuration is supported for the configuration of IAB-node DU resources. In addition, dynamic indication (L1 signalling) to an IAB-node of the availability of soft resources for an IAB-node DU is supported. Existing Rel.15 L1 signalling methods as the baseline, while potential enhancements (e.g. new slot formats), rules for DU/MT behaviour in case of conflicts across multiple hops, and processing time constraints at the IAB-node may need to be considered.

Tables 7.3.3-1 and 7.3.3-2 capture the possible combinations of DU and MT behavior. The tables assume an IAB not capable of full-duplex operation. In the tables below the following definitions apply:

- "MT: Tx" means that the MT should transmit if scheduled;
- "DU: Tx" means that the DU may transmit;
- "MT: Rx" means that the MT should be able to receive (if there is anything to receive);
- "DU: Rx" means that the DU may schedule uplink transmissions from child nodes or UEs;
- "MT: Tx/Rx" means that the MT should transmit if scheduled and should be able to receive, but not simultaneously;
- "DU: Tx/Rx" means that the DU may transmit and may schedule uplink transmission from child nodes and UEs, but not simultaneously;
- "IA" means that the DU resource is explicitly or implicitly indicated as available;
- "INA" means that the DU resource is explicitly or implicitly indicated as not available;

- "MT: NULL" means that the MT does not transmit and does not have to be able to receive;
- "DU: NULL" means that the DU does not transmit and does not schedule uplink transmission from child nodes and UEs.

5 Table 7.3.3-1 applies in case of [time division multiplexing (TDM)] operation, where there can be no simultaneous transmission in the DU and the MT, nor any simultaneous reception in the DU and the MT.

Table 7.3.3-1: DU and MT behavior in case of TDM operation

DU Configuration	MT configuration		
	DL	UL	F
DL-H	DU: Tx MT: NULL	DU: Tx MT: NULL	DU: Tx MT: NULL
DL-S	When DU resource: IA DU: Tx MT: NULL	When DU resource: IA DU: Tx MT: NULL	When DU resource: IA DU: Tx MT: NULL
	When DU resource: INA DU: NULL MT: Rx	When DU resource: INA DU: NULL MT: Tx	When DU resource: INA DU: NULL MT: Tx/Rx
UL-H	DU: Rx MT: NULL	DU: Rx MT: NULL	DU: Rx MT: NULL
UL-S	When DU resource: IA DU: Rx MT: NULL	When DU resource: IA DU: Rx MT: NULL	When DU resource: IA DU: Rx MT: NULL
	When DU resource: INA DU: NULL MT: Rx	When DU resource: INA DU: NULL MT: Tx	When DU resource: INA DU: NULL MT: Tx/Rx
F-H	DU: Tx/Rx MT: NULL	DU: Tx/Rx MT: NULL	DU: Tx/Rx MT: NULL
F-S	When DU resource: IA DU: Tx/Rx MT: NULL	When DU resource: IA DU: Tx/Rx MT: NULL	When DU resource: IA DU: Tx/Rx MT: NULL
	When DU resource: INA DU: NULL MT: Rx	When DU resource: INA DU: NULL MT: Tx	When DU resource: INA DU: NULL MT: Tx/Rx
NA	DU: NULL MT: Rx	DU: NULL MT: Tx	DU: NULL MT: Tx/Rx

10 Table 7.3.3-2 applies in case of space division multiplexing (SDM) operation, where there can be simultaneous transmission in the DU and the MT, alternatively simultaneous reception in the DU and the MT.

Table 7.3.3-2: DU and MT behaviour in case of SDM operation

	DL	UL	F
<i>DL-H</i>	<i>DU: Tx MT: NULL</i>	<i>DU: Tx MT: Tx</i>	<i>DU: Tx MT: Tx</i>
<i>DL-S</i>	<i>When DU resource: IA DU: Tx MT: NULL</i>	<i>When DU resource: IA DU: Tx MT: Tx</i>	<i>When DU resource: IA DU: Tx MT: Tx</i>
	<i>When DU resource: INA DU: NULL MT: Rx</i>	<i>When DU resource: INA DU: NULL MT: Tx</i>	<i>When DU resource: INA DU: NULL MT: Tx/Rx</i>
<i>UL-H</i>	<i>DU: Rx MT: Rx</i>	<i>DU: Rx MT: NULL</i>	<i>DU: Rx MT: Rx</i>
<i>UL-S</i>	<i>When DU resource: IA DU: Rx MT: Rx</i>	<i>When DU resource: IA DU: Rx MT: NULL</i>	<i>When DU resource: IA DU: Rx (only if MT is Rx and the DU knows that ahead of time) MT: Rx</i>
	<i>When DU resource: INA DU: NULL MT: Rx</i>	<i>When DU resource: INA DU: NULL MT: Tx</i>	<i>When DU resource: INA DU: NULL MT: Tx/Rx</i>
<i>F-H</i>	<i>DU: Tx/Rx MT: Rx (only if DU is Rx and the parent DU is aware in advance)</i>	<i>DU: Tx/Rx MT: Tx (only if DU is Tx and the parent is aware in advance)</i>	<i>DU: Tx/Rx MT: Tx (only if DU is Tx and the parent DU knows that ahead of time), Rx (only if DU is Rx and the parent DU is aware in advance)</i>
<i>F-S</i>	<i>When DU resource: IA DU: Tx/Rx MT: Rx (only if DU is Rx and the parent DU is aware in advance)</i>	<i>When DU resource: IA DU: Tx/Rx MT: Tx (only if DU is Tx and the parent DU is aware in advance)</i>	<i>When DU resource: IA DU: Tx/Rx MT: Tx (only if DU is Tx and the parent DU knows that ahead of time), Rx (only if DU is Rx and the parent DU is aware in advance)</i>
	<i>When DU resource: INA DU: NULL MT: Rx</i>	<i>When DU resource: INA DU: NULL MT: Tx</i>	<i>When DU resource: INA DU: NULL MT: Tx/Rx</i>
<i>NA</i>	<i>DU: NULL MT: Rx</i>	<i>DU: NULL MT: Tx</i>	<i>DU: NULL MT: Tx/Rx</i>

”

Figure 5a shows a schematic representation of IAB node connected to an IAB donor node in a single connectivity (SC) scenario. In the single connectivity scenario, the MT part of the IAB node may be connected to IAB donor node DU via an MCG IAB parent node.

5

Figure 5b shows a schematic representation of IAB node connected to IAB donor nodes in a DC scenario. In the DC scenario, the MT part of the IAB node may be connected to an IAB donor node via an MCG IAB parent node and via a SCG IAB parent node.

10

DC may enable topological redundancy by providing an alternative link and/or a redundant route to the IAB donor node. This may improve the reliability and robustness for potential link failures.

5

In an in-band IAB scenario both MCG and SCG parent links between the IAB node and the MCG and SCG parent nodes may operate on the same carrier (i.e. intra-frequency dual connectivity). Also, the child links between the IAB node and user equipment may operate on the same carrier. The IAB node may be limited with the
10 half-duplex constraint where the transmission and reception cannot happen at the same time instant.

The IAB node may be a dual-MT IAB node and comprise two (logical) MT part, each having a separate single connectivity to the IAB parent nodes. However, it will be
15 understood that from a resource usage perspective, there may be no difference to DC with a single MT. One or more of the following aspect relate to the single MT case but the principles are similarly applicable for dual-MT case except that there may be two MCGs configured instead of MCG and SCG. There may also be differences in operation and control on higher layers.

20

Figure 6 shows basic connections between the IAB nodes and access UEs. From the middle IAB node perspective, there will be parent BH links as well as child BH and access links, all for both UL and/or DL.

25

As discussed above the IAB node may contain two separate parts: a MT part, which may facilitate parent BH connections between IAB parent nodes and the IAB node; and a DU part, which may facilitate child BH connections between the IAB node and IAB child nodes and/or between the IAB node and UEs (connected to the IAB node
30 via Access link).

Resource configuration may be made by means of separate configurations: separately for DU and MT parts of the IAB node and/or separately for each IAB node.

5 Resource configuration for an MCG link and an SCG link may be made by means of separate configurations: one resource configuration for the MCG link and another resource configuration for the SCG link

10 A challenge may be to ensure that IAB node connected to two IAB parent nodes (e.g. one via an MCG link and another via a SCG link) has a consistent resource configuration for two backhaul links such that: IAB capabilities may be maximally reused, resource conflict due to IAB capability and/or link direction conflict may be avoided, there are sufficient means for CU to adjust/adapt the resources available for the MCG link and the SCG link and/or signalling complexity may be minimized.

15 It should be noted that in the case of DC, connection between the involved DUs may not be available, or if it is available it may be delayed and may have limited capacity. Furthermore, involved DUs may be able to operate separately with minimum amount of coordination.

20 Dual connectivity for UEs is not supported for intra-band scenario in NR Rel-15 (DC is supported only for inter-band scenario, where UE configuration can be fully independent between different cells).

25 One or more of the following aspects relate to the issue of operating an IAB node in the DC scenario where MT resources of the IAB node are configured separately for (at least) two parent nodes, MCG and (at least one) SCG. Two (or more) parent nodes may operate under the same CU or two (or more) parent node may operate under different CUs.

30 An example of the considered scenario is shown in Figure 7. The MCG link and the SCG may be operating at the same frequency band (TDD) or on separate frequency bands.

One or more of the following aspects propose to determine a MT resource type for a MCG link and/ or a MT resource type for a SCG link for a time domain resource based on one or more of the following parameters:

- MT resource configuration corresponding to the MCG link: UL, DL or Flexible;

5 - MT resource configuration corresponding to the SCG link: UL, DL or Flexible;

and

- Duplexing configuration between the MCG link and the SCG link: TDM vs. SDM/FDM.

10 Depending on the duplexing configuration, the MT resource type may be one of the following:

- TDM between the MCG link and the SCG link: MCG link available only or SCG link available only; and

15 - SDM/FDM the MCG link and the SCG link: MCG link and SCG link both available, MCG link available only or SCG link available only.

When operating according to TDM between the MCG link and the SCG link, at least one predefined resource configuration combination (MT resource configuration corresponding to the MCG link and MT resource configuration corresponding to the SCG link) may indicate that the MT resource type is available (i.e. reserved) for the SCG link (and not available for the MCG link). Figure 8 shows an example of a table according to this aspect:

- MCG link Flexible and SCG link DL: SCG link DL;

- MCG link Flexible and SCG link UL: SCG link UL; and

25 - Other combinations: MCG link according to MCG link configuration.

More specifically, when the MT configuration of the MCG link is DL and the MT configuration of the SCG link is DL, the MT resource type of the MCG link may be DL and the MT resource type of the SCG may be not available (NA).

30

When the MT configuration of the MCG link is DL and the MT configuration of the SCG link is UL, the MT resource type of the MCG link may be DL and the MT resource type of the SCG may be NA.

When the MT configuration of the MCG link is DL and the MT configuration of the SCG link is flexible, the MT resource type of the MCG link may be DL and the MT resource type of the SCG may be NA.

5

When the MT configuration of the MCG link is UL and the MT configuration of the SCG link is DL, the MT resource type of the MCG link may be UL and the MT resource type of the SCG may be NA.

10 When the MT configuration of the MCG link is UL and the MT configuration of the SCG link is UL, the MT resource type of the MCG link may be UL and the MT resource type of the SCG may be NA.

15 When the MT configuration of the MCG link is UL and the MT configuration of the SCG link is flexible, the MT resource type of the MCG link may be UL and the MT resource type of the SCG may be NA.

20 When the MT configuration of the MCG link is flexible and the MT configuration of the SCG link is DL, the MT resource type of the MCG link may be NA and the MT resource type of the SCG may be DL.

25 When the MT configuration of the MCG link is flexible and the MT configuration of the SCG link is UL, the MT resource type of the MCG link may be NA and the MT resource type of the SCG may be UL.

25

When the MT configuration of the MCG link is flexible and the MT configuration of the SCG link is flexible, the MT resource type of the MCG link may be NA and the MT resource type of the SCG may be NA.

30 It should be noted that this mode of operation (i.e. TDM between MCG and SCG) can be made available also when IAB node supports FDM or SDM between the MCG link and the SCG link.

When operating according to FDM or SDM between the MCG link and the SCG link, at least one predefined resource configuration combination (MT resource configuration corresponding to the MCG link and MT resource configuration corresponding to the SCG link) may indicate that the MT resource type is available (i.e. reserved) for both the SCG link and the MCG link. Figure 9 shows an example of a table according to this aspect:

- MCG link DL and SCG link DL: MCG link and SCG link DL;
- MCG link UL and SCG link UL: MCG link and SCG link UL; and
- Other combinations: MCG link according to MCG link configuration.

More specifically, when the MT configuration of the MCG link is DL and the MT configuration of the SCG link is DL, the MT resource type of the MCG link may be DL and the MT resource type of the SCG may be DL.

When the MT configuration of the MCG link is DL and the MT configuration of the SCG link is UL, the MT resource type of the MCG link may be DL and the MT resource type of the SCG may be NA.

When the MT configuration of the MCG link is DL and the MT configuration of the SCG link is flexible, the MT resource type of the MCG link may be DL and the MT resource type of the SCG may be NA.

When the MT configuration of the MCG link is UL and the MT configuration of the SCG link is DL, the MT resource type of the MCG link may be UL and the MT resource type of the SCG may be NA.

When the MT configuration of the MCG link is UL and the MT configuration of the SCG link is UL, the MT resource type of the MCG link may be UL and the MT resource type of the SCG may be UL.

When the MT configuration of the MCG link is UL and the MT configuration of the SCG link is flexible, the MT resource type of the MCG link may be UL and the MT resource type of the SCG may be NA.

- 5 When the MT configuration of the MCG link is flexible and the MT configuration of the SCG link is DL, the MT resource type of the MCG link may be flexible and the MT resource type of the SCG may be NA.

- 10 When the MT configuration of the MCG link is flexible and the MT configuration of the SCG link is UL, the MT resource type of the MCG link may be flexible and the MT resource type of the SCG may be NA.

- 15 When the MT configuration of the MCG link is flexible and the MT configuration of the SCG link is flexible, the MT resource type of the MCG link may be flexible and the MT resource type of the SCG may be NA.

- In one implementation, at least one predefined resource configuration combination (MT resource configuration corresponding to the MCG link and MT resource configuration corresponding to the SCG link may indicate that the MT resource type is available (i.e. reserved) for the SCG link also in the FDM or SDM scenario. Figure 10 shows an example of a table according to this aspect:

- MCG link Flex and SCG link DL: SCG link DL; and
- MCG link Flex and SCG link UL: SCG link UL.

- 25 When the MT configuration of the MCG link is DL and the MT configuration of the SCG link is DL, the MT resource type of the MCG link may be DL and the MT resource type of the SCG may be DL.

- 30 When the MT configuration of the MCG link is DL and the MT configuration of the SCG link is UL, the MT resource type of the MCG link may be DL and the MT resource type of the SCG may be NA.

When the MT configuration of the MCG link is DL and the MT configuration of the SCG link is flexible, the MT resource type of the MCG link may be DL and the MT resource type of the SCG may be NA.

- 5 When the MT configuration of the MCG link is UL and the MT configuration of the SCG link is DL, the MT resource type of the MCG link may be UL and the MT resource type of the SCG may be NA.

10 When the MT configuration of the MCG link is UL and the MT configuration of the SCG link is UL, the MT resource type of the MCG link may be UL and the MT resource type of the SCG may be UL.

15 When the MT configuration of the MCG link is UL and the MT configuration of the SCG link is flexible, the MT resource type of the MCG link may be UL and the MT resource type of the SCG may be NA.

20 When the MT configuration of the MCG link is flexible and the MT configuration of the SCG link is DL, the MT resource type of the MCG link may be NA and the MT resource type of the SCG may be DL.

When the MT configuration of the MCG link is flexible and the MT configuration of the SCG link is UL, the MT resource type of the MCG link may be NA and the MT resource type of the SCG may be UL.

- 25 When the MT configuration of the MCG link is flexible and the MT configuration of the SCG link is flexible, the MT resource type of the MCG link may be flexible and the MT resource type of the SCG may be NA.

30 The duplexing operation may be determined based on indication received from CU or IAB parent node. It may depend also on the IAB capability (e.g. based on such as number of antenna panels, baseband processing capability).

The starting point for resource configuration is such that resources may be given as semi-static configuration by CU. The main purpose of SCG link may be to provide redundant link for the case when the quality of the MCG link fails. The redundant link may be utilized for topological robustness to cope with the failure scenarios providing alternative route if either one of the links fail. The other usage may be to balance the load between the BH links as the traffic load varies.

IAB parent node may be able to dynamically adapt the MT resources based on DCI Format 2_0 or based on other DCIs such as dedicated DCI (e.g. DL resource allocation grant, or UL resource allocation grant). If the link having dynamic configuration is the SCG link, this may allow the SCG to use more resources to handle sudden variation of the SCG link's quality.

If even more scheduling opportunities through the SCG link is wanted, the roles of the MCG link and the SCG link may be swapped. For example, if the MCG link fails completely, the SCG link resources may be used to perform the swapping.

When a time resource is configured as "Flexible" by semi-static configuration at an IAB node, an IAB parent node may re-configure it as "DL" or "UL" by dynamic configuration (e.g. DCI 2_0). Separate DCI 2_0 may be defined for both the MCG link and the SCG link. Dynamic DCI indicated via DCI Format 2_0 may override semi-static resource configuration for the involved link (MCG link or SCG link). This provides, for example, possibilities for increasing and/or decreasing the SCG resources dynamically by the scheduling node (via rules discussed above).

For example, an SCG link flexible time resource may be turned to DL or UL by DCI format 2_0. The corresponding time resources may become available for the SCG link, provided that the MCG link is flexible.

In one implementation, only one IAB parent node may use dynamic configurations and the other IAB parent node may use a semi-static configuration. When the MCG link (or SCG link) is having dynamic configuration and the SCG link (or MCG link) is having a

semi-static configuration, the rules discussed above may still hold. Using this approach, the IAB parent node may temporarily pull some time resources from the SCG link to the MCG link (or vice versa).

- 5 It will be understood that for semi-static resource configuration, MT resources for the IAB node may be configured by the CU (e.g. via RRC signalling), separately for the MCG link and the SCG link. The CU may also perform DU configuration, separately for the MCG link and the SCG link.
- 10 For DCI 2_0, the CU may configure DCI 2_0 separately for the MCG link and the SCG link. The DU part of the IAB node may need to be configured accordingly.

Figure 11 shows an example of how to determine MT resource type for an MCG link and an SCG link with given MCG link and SCG link configurations in the case of TDM
15 between the MCG link and the SCG link. This follows operation according to the table of Figure 8.

Figure 12 shows an example of how to determine MT resource type for an MCG link and an SCG link with given MCG link and SCG link configurations in the case of SDM
20 or FDM between the MCG link and the SCG link. This follows operation according to the table of Figure 9.

The proposed principle may be applied in scenarios with multiple SCG links if such extension is specified in future releases of NR. For example, the following operation
25 can be defined for the TDM duplexing scenario: the CU may play with configuration (only the configuration of a selected SCG link is DL or UL, other are Flex); there may be a predefined priority order between the SCG links (e.g. according to an SCG link index). Only the one with the highest priority may be selected.

30 Figure 13 shows a block diagram of a method for communicating over a master cell group link and a secondary cell group link in a dual connectivity scenario. The method may be performed by an IAB node comprising a single MT part providing dual

connectivity to an MCG parent node via an MCG link and to an SCG parent node via an SCG link. It will be understood that the method may also be performed by an IAB node comprising a two MT parts providing dual connectivity to an MCG parent node via an MCG link and to an SCG parent node via an SCG link.

5

In step 1302 the IAB node may receive an MT resource configuration for the MCG link, for example from the MCG parent node. The MT resource configuration for the MCG link may correspond to a selected time resource. The MT resource configuration for the MCG link may be DL, UL or Flexible. The MT resource configuration for the MCG link may be a semi-static RRC configuration, for example received from the MCG IAB parent node, and/or may be dynamically adjusted, for example by the MCG IAB parent node, based on DCI 2_0. The control of semi-static or dynamic configurations may be on CU and the signalling path may go through the MCG link.

15 In step 1304 the IAB node may receive an MT resource configuration for the SCG link, for example from the SCG parent node. The MT resource configuration for the SCG link may correspond to the selected time resource. The MT resource configuration for the SCG link may be DL, UL or Flexible. The MT resource configuration for the SCG link may be a semi-static RRC configuration, for example received from the SCG IAB parent node, and/or may be dynamically adjusted, for example by the SCG IAB parent node, based on DCI 2_0.

The MT resource configuration for the SCG link may be the same as the MT resource configuration for the MCG link or different than the MT resource configuration for the MCG link.

25

In step 1306 the IAB mode may determine a mode of operation (i.e. duplexing configuration) between the MCG link and the SCG link. The mode of operation may be determined for the selected time resource. The mode of operation may be TDM, SDM or FDM. The mode of operation may be determined based on an indication received from the MCG IAB parent node, the SCG IAB parent node, a CU or other.

30

It will be understood that steps 1302, 1302 and 1306 may be performed in a different order.

It will also be understood that the selected time resource may comprise a single
5 frequency resource for the MCG link and the SCG link when the mode of operation is TDM or SDM or two frequency resources for the MCG link and the SCG link when the mode of operation is FDM. Furthermore, the frequency resources may be configured separately for the MCG link and the SCG link.

10 In step 1308 the IAB node may determine an MT resource type for the MCG link and/or an MT resource type for the SCG link based on the MT resource configuration for the MCG link, MT resource configuration for the SCG link and the mode of operation. The MT resource types may be determined for the selected time resource. The MT resource types may be available (i.e. DL, UL or Flexible) or not available. When the
15 mode of operation is TDM, the MT resource types may be determined based on the table of Figure 8 and/or the block diagram of Figure 11. When the mode of operation is SDM or FDM, the MT resource types may be determined based on the table of Figures 9 or 10 and/or the block diagram of Figure 12.

20 In step 1310 the IAB node may share (not mandatory) the MT resource type for the MCG link and/or the MT resource type for the SCG link respectively with the MCG parent node and/or the SCG parent node for scheduling communication over the MCG link and/or the SCG link. The IAB node may communicate over the MCG link and/or the SCG link during the selected time resource according to the MT resource type for
25 the MCG link and the MT resource type for the second MCG link determined in step 1308.

Figure 14 shows a block diagram of a method for communicating over a master cell group link and another master cell group link in a double single connectivity scenario.

30 The method may be performed by an IAB node comprising two MT parts, with an MT part providing single connectivity to a first MCG parent node via a first MCG link and

another MT part providing single connectivity to a second MCG parent node via a second MCG link.

In step 1402 the IAB node may receive an MT resource configuration for the first MCG link, for example from the first MCG parent node. The MT resource configuration for the first MCG link may correspond to a selected time resource. The MT resource configuration for the first MCG link may be DL, UL or Flexible. The MT resource configuration for the first MCG link may be a semi-static RRC configuration, for example received from the first MCG IAB node, and/or may be dynamically adjusted, for example by the first MCG IAB parent node, based on DCI 2_0.

In step 1404 the IAB node may receive an MT resource configuration for the second MCG link, for example from the second MCG parent node. The MT resource configuration for the second MCG link may correspond to the selected time resource. The MT resource configuration for the second MCG link may be DL, UL or Flexible. The MT resource configuration for the second MCG link may be a semi-static RRC configuration, for example received from the second MCG IAB node, and/or may be dynamically adjusted, for example by the second MCG IAB parent node, based on DCI 2_0.

The MT resource configuration for the second MCG link may be the same as the MT resource configuration for the first MCG link or different than the MT resource configuration for the first MCG link.

In step 1406 the IAB mode may determine a mode of operation (i.e. duplexing configuration) between the first MCG link and the second MCG link. The mode of operation may be determined for the selected time resource. The mode of operation may be TDM, SDM or FDM. The mode of operation may be determined based on an indication received from the first MCG IAB parent node, the second MCG IAB parent node, a CU or other.

It will be understood that steps 1402, 1402 and 1406 may be performed in a different order.

It will be understood that the selected time resource may comprises a single frequency resource for the first MCG link and the second MCG link when the mode of operation is TDM or SDM or two frequency resources for the first MCG link and the second MCG link when the mode of operation is FDM. Furthermore, the frequency resource may be configured separately for the MCG link and the SCG link.

10 In step 1408 the IAB may determine an MT resource type for the first MCG link and/or an MT resource type for the second MCG link based on the MT resource configuration for the first MCG link, MT resource configuration for the second MCG link and the mode of operation. The MT resource types may be determined for the selected time resource. The MT resource types may be available (i.e. DL, UL or Flexible) or not
15 available. When the mode of operation is TDM, the MT resource types may be determined based on the table of Figure 8 and/or the block diagram of Figure 11. When the mode of operation is SDM or FDM, the MT resource types may be determined based on the table of Figures 9 or 10 and/or the block diagram of Figure 12.

20 In step 1410 the IAB may share the MT resource type for the first MCG link and/or the MT resource type for the second MCG link respectively with the first MCG parent node and/or the second MCG parent node for scheduling communication over the first MCG link and/or the second MCG link. The IAB node may communicate over the first MCG
25 link and/or the second MCG link during the selected time resource according to the MT resource type for the first MCG link and the MT resource type for the second MCG link.

Figure 15 shows a schematic representation of non-volatile memory media 1500a (e.g. computer disc (CD) or digital versatile disc (DVD)) and 1500b (e.g. universal serial bus (USB) memory stick) storing instructions and/or parameters 1502 which when
30

executed by a processor allow the processor to implement one or more of the aspects of Figures 1 to 14.

It will be understood that one or more of the above aspect may provide some or all of the following advantages:

- Support any number of SCG IAB nodes (i.e. scalability);
- Support both scenarios: MCG link and SCG link have the same or different number of hops;
- Small amount of signalling needed;
- Support dynamic adjustment of resources available for MCG link and/or SCG link;
- Support hybrid operation of TDM, FDM and/or SDM between the MCG link and/ or the SCG link using the same resource configuration framework;
- Supports both TDM and FDM or SDM between Parent BH link and Child access links; and
- May not require coordination between MCG link and SCG link.

It is noted that while the above describes example embodiments, there are several variations and modifications which may be made to the disclosed solution without departing from the scope of the present invention.

The embodiments may thus vary within the scope of the attached claims. In general, some embodiments may be implemented in hardware or special purpose circuits, software, logic or any combination thereof. For example, some aspects may be implemented in hardware, while other aspects may be implemented in firmware or software which may be executed by a controller, microprocessor or other computing

device, although embodiments are not limited thereto. While various embodiments may be illustrated and described as block diagrams, flow charts, or using some other pictorial representation, it is well understood that these blocks, apparatus, systems, techniques or methods described herein may be implemented in, as non-limiting
5 examples, hardware, software, firmware, special purpose circuits or logic, general purpose hardware or controller or other computing devices, or some combination thereof.

The embodiments may be implemented by computer software stored in a memory and
10 executable by at least one data processor of the involved entities or by hardware, or by a combination of software and hardware. Further in this regard it should be noted that any procedures, e.g., as in Figures 11 to 13, may represent program steps, or interconnected logic circuits, blocks and functions, or a combination of program steps and logic circuits, blocks and functions. The software may be stored on such physical
15 media as memory chips, or memory blocks implemented within the processor, magnetic media such as hard disk or floppy disks, and optical media such as for example DVD and the data variants thereof, CD.

The memory may be of any type suitable to the local technical environment and may
20 be implemented using any suitable data storage technology, such as semiconductor-based memory devices, magnetic memory devices and systems, optical memory devices and systems, fixed memory and removable memory. The data processors may be of any type suitable to the local technical environment, and may include one or more of general purpose computers, special purpose computers,
25 microprocessors, digital signal processors (DSPs), application specific integrated circuits (ASIC), gate level circuits and processors based on multi-core processor architecture, as non-limiting examples.

Alternatively or additionally some embodiments may be implemented using circuitry.
30 The circuitry may be configured to perform one or more of the functions and/or method steps previously described. That circuitry may be provided in the base station and/or in the communications device.

As used in this application, the term "circuitry" may refer to one or more or all of the following:

- 5 (a) hardware-only circuit implementations (such as implementations in only analogue and/or digital circuitry);
- (b) combinations of hardware circuits and software, such as:
 - (i) a combination of analogue and/or digital hardware circuit(s) with software/firmware and
 - 10 (ii) any portions of hardware processor(s) with software (including digital signal processor(s)), software, and memory(ies) that work together to cause an apparatus, such as the communications device or base station to perform the various functions previously described; and
- (c) hardware circuit(s) and or processor(s), such as a microprocessor(s) or a portion of a microprocessor(s), that requires software (e.g., firmware) for operation,
15 but the software may not be present when it is not needed for operation.

This definition of circuitry applies to all uses of this term in this application, including in any claims. As a further example, as used in this application, the term circuitry also covers an implementation of merely a hardware circuit or processor (or multiple
20 processors) or portion of a hardware circuit or processor and its (or their) accompanying software and/or firmware. The term circuitry also covers, for example integrated device.

The foregoing description has provided by way of exemplary and non-limiting
25 examples a full and informative description of some embodiments. However, various modifications and adaptations may become apparent to those skilled in the relevant arts in view of the foregoing description, when read in conjunction with the accompanying drawings and the appended claims. However, all such and similar modifications of the teachings will still fall within the scope as defined in the appended
30 claims.

CLAIMS

1. An apparatus comprising:
at least one processor; and
at least one memory including computer program code;
5 the at least one memory and the computer program code configured to, with
the at least one processor, cause the apparatus at least to:
receive a resource configuration for a first cell group link;
receive a resource configuration for a second cell group link;
determine a mode of operation; and
10 determine a resource type for the first cell group link or the second cell group
link based on the resource configuration for the first cell group link, the resource
configuration for the second cell group link and the mode of operation.
2. The apparatus of claim 1, wherein the at least one memory and the computer
15 program code configured to, with the at least one processor, cause the apparatus at
least to:
determine a resource type for the first cell group link and a resource type for
the second cell group link based on the resource configuration for the first cell group
link, the resource configuration for the second cell group link and the mode of
20 operation.
3. The apparatus of any of claims 1 to 2, wherein the resource is a time domain
resource.
- 25 4. The apparatus of any of claims 1 to 3, wherein the resource configuration for
the first cell group link indicates a resource type.
5. The apparatus of any of claims 1 to 4, wherein the resource configuration for
the second cell group link indicates a resource type.

6. The apparatus of any of claims 1 to 5, wherein the resource type for the first cell group link or the second cell group link is one of: 'downlink', 'uplink', 'flexible' or 'not available'.

5 7. The apparatus of any of claims 1 to 6, wherein the mode of operation is time division duplexing between the first cell group link and the second cell group link.

8. The apparatus of any of claim 7, wherein the at least one memory and the computer program code configured to, with the at least one processor, cause the
10 apparatus at least to:

determine that the resource configuration for the first cell group link and the resource configuration for the second cell group link form a predefined combination;
and

15 determine that the resource type for the first cell group link is 'not available' and the resource type for the second cell group link is 'downlink', 'uplink' or 'flexible'.

9. The apparatus of claim 8, wherein the predefined combination is one of:
the resource configuration for the first cell group link is 'flexible' and the resource configuration for the second cell group link is 'downlink'; or
20 the resource configuration for the first cell group link is 'flexible' and the resource configuration for the second cell group link is 'uplink'.

10. The apparatus of any of claims 8 and 9, wherein the resource type for the second cell group link is 'downlink' or 'uplink' based on the resource configuration of
25 the second cell group link.

11. The apparatus of any of claims 7 to 10, wherein the at least one memory and the computer program code configured to, with the at least one processor, cause the apparatus at least to:

30 determine that the resource configuration for the first cell group link and the resource configuration for the second cell group link form a predefined combination;
and

determine that the resource type for the first cell group link is 'downlink', 'uplink' or 'flexible' and the resource type for the second cell group link is 'resource not available'.

- 5 12. The apparatus of claim 11, wherein the predefined combination is one of:
the resource configuration for the first cell group link is 'downlink' and the resource configuration for the second cell group link is 'flexible'; or
the resource configuration for the first cell group link is 'uplink' and the resource configuration for the second cell group link is 'flexible'.

10

13. The apparatus of any of claims 11 and 12, wherein the resource type for the first cell group link is 'downlink' or 'uplink' based on the resource configuration of the first cell group link.

- 15 14. The apparatus of any of claims 1 to 6, wherein the mode of operation is spatial division duplexing or frequency division duplexing between the first cell group link and the second cell group link.

15. The apparatus of claim 15, wherein the at least one memory and the computer program code configured to, with the at least one processor, cause the apparatus at least to:

20 determine that the resource configuration for the first cell group link and the resource configuration for the second cell group link form a predefined combination;
and

- 25 determine that the resource type for the first cell group link is 'downlink', 'uplink' or 'flexible' and the resource type for the second cell group link is 'not available'.

16. The apparatus of claim 15, wherein the predefined combination is one of:
the resource configuration for the first cell group link is 'downlink' and the resource configuration for the second cell group link is 'flexible'; or
30 the resource configuration for the first cell group link is 'uplink' and the resource configuration for the second cell group link is 'flexible'.

17. The apparatus of any of claims 15 and 16, wherein the resource type for the first cell group link is 'downlink' or 'uplink' based on the resource configuration of the first cell group link.

5

18. The apparatus of any of claim 14, wherein the at least one memory and the computer program code configured to, with the at least one processor, cause the apparatus at least to:

10 determine that the resource configuration for the first cell group link and the resource configuration for the second cell group link form a predefined combination; and

determine that the resource type for the first cell group link is 'downlink', 'uplink' or 'flexible' and the resource type for the second cell group link is 'available'.

15 19. The apparatus of claim 18, wherein the predefined combination is one of:

the resource configuration for the first cell group link is 'downlink' and the resource configuration for the second cell group link is 'downlink'; or

the resource configuration for the first cell group link is 'uplink' and the resource configuration for the second cell group link is 'uplink'.

20

20. The apparatus of any of claims 18 and 19, wherein the resource type for the first cell group link is 'downlink' or 'uplink' based on the resource configuration of the first cell group link and the resource type for the second cell group link is 'downlink' or 'uplink' based on the resource configuration of the second cell group link.

25

21. The apparatus of claim 2 and any of claims 14 to 20, wherein the time domain resource comprises a first frequency domain resource for the first cell group link and a second frequency domain resource for the second cell group link.

30 22. The apparatus of any of claims 1 to 21, wherein at least one of the resource configuration for the first cell group link and the resource configuration for the second cell group link is a semi-static configuration.

23. The apparatus of claim 22, wherein the at least one memory and the computer program code configured to, with the at least one processor, cause the apparatus at least to:

5 adjust the at least one of the resource type for the first cell group link and the resource type for the second cell group link based on a dynamic downlink control information.

24. The apparatus of any of claims 1 to 21, wherein one of the resource
10 configuration for the first cell group link and the resource configuration for the second cell group link is a semi-static configuration and the other one of the resource configuration for the first cell group link and the resource configuration for the second cell group link is a dynamic configuration.

15 25. The apparatus of any of claims 1 to 24, wherein the apparatus is an integrated access and backhaul node.

26. The apparatus of claim 25, comprising:

20 a single mobile terminal part providing dual connectivity to two integrated access and backhaul parent nodes, wherein the first cell link is a master cell link and the second cell link is a secondary cell link; or

 two mobile terminal parts each providing single connectivity to a respective integrated access and backhaul parent node, wherein the first cell link is a master cell link and the second cell link is another master cell link.

25

27. The apparatus of any of claims 25 and 26, wherein the mode of operation is determined based on an indication received from an integrated access and backhaul parent node or a centralized unit.

30 28. A method comprising:

 receive a resource configuration for a first cell group link;

 receive a resource configuration for a second cell group link;

determine a mode of operation; and

determine a resource type for the first cell group link or the second cell group link based on the resource configuration for the first cell group link, the resource configuration for the second cell group link and the mode of operation.

5

29. A computer program comprising computer executable instructions which when run on one or more processors perform the steps of any of the method of claim 28.

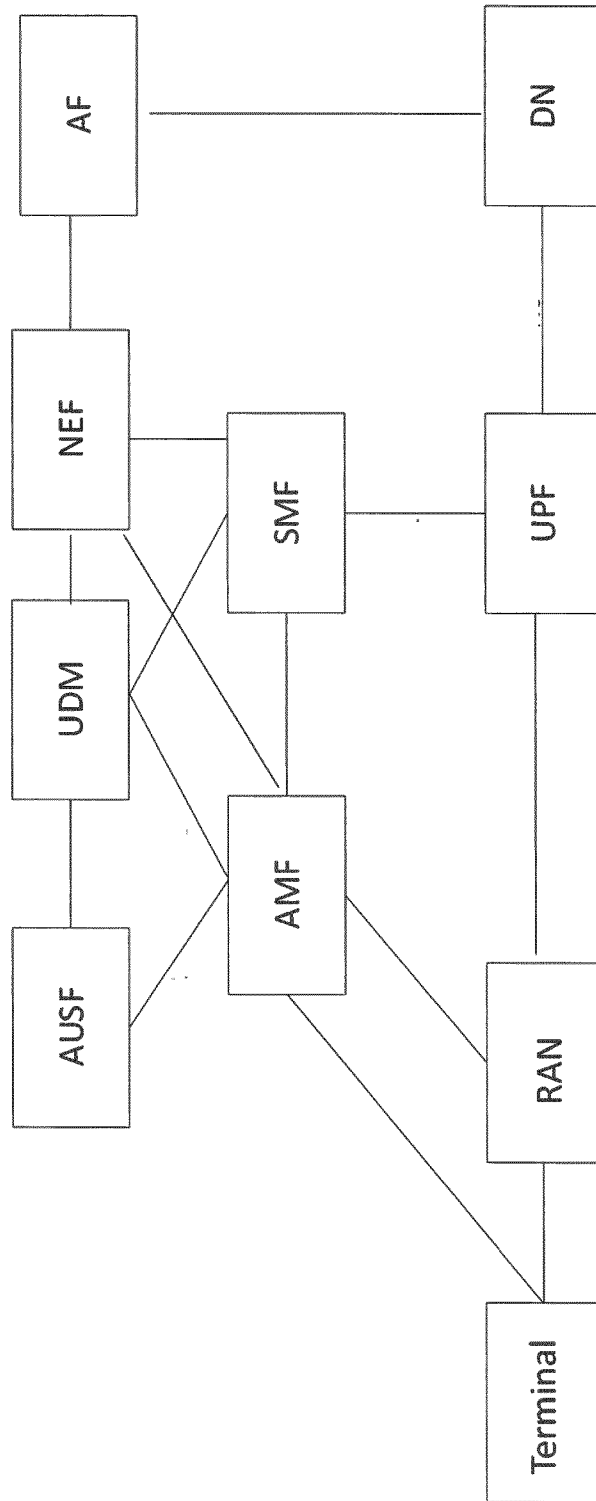

Fig. 1

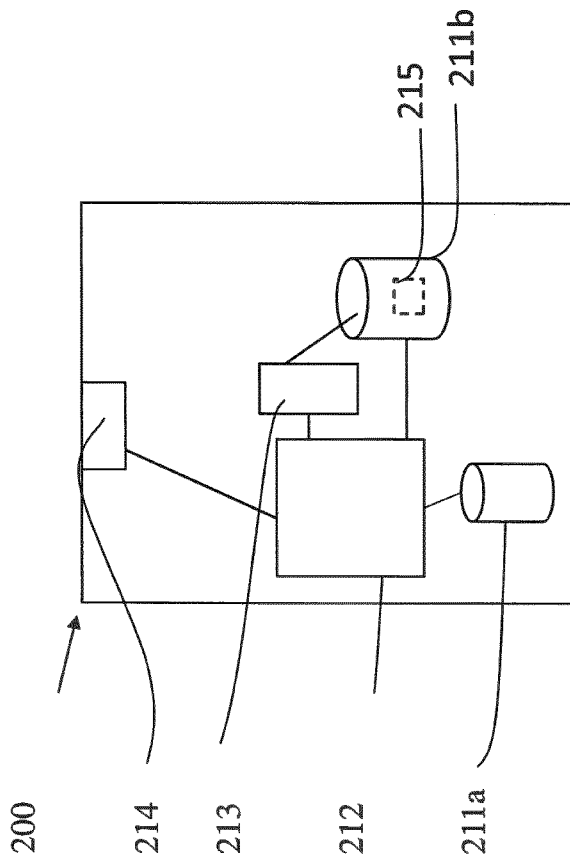

Fig. 2

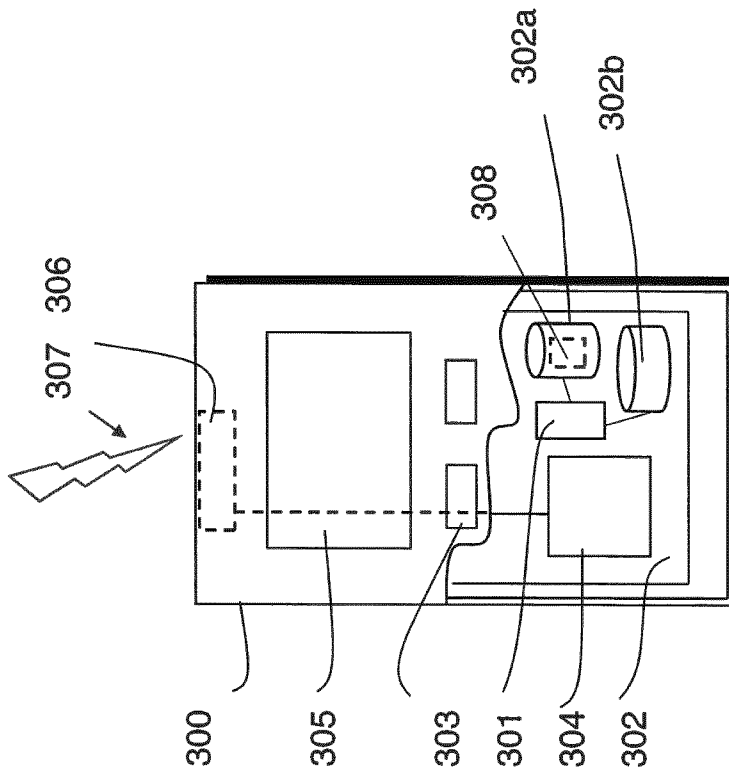

Fig. 3

4/16

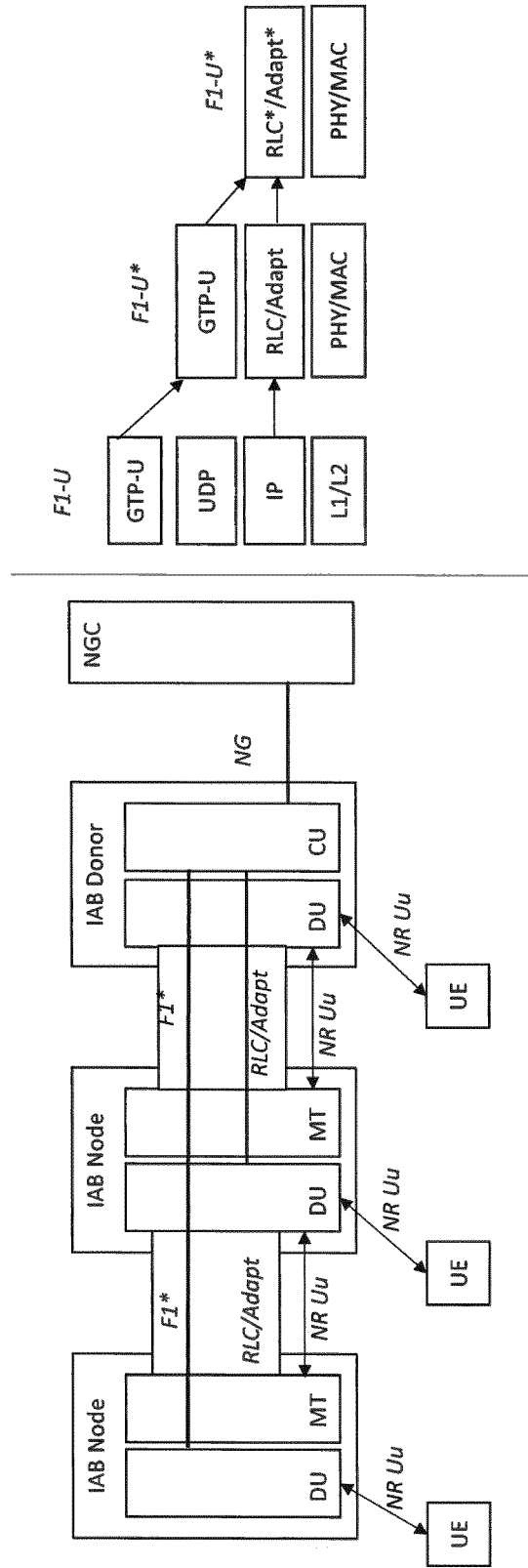

Fig. 4

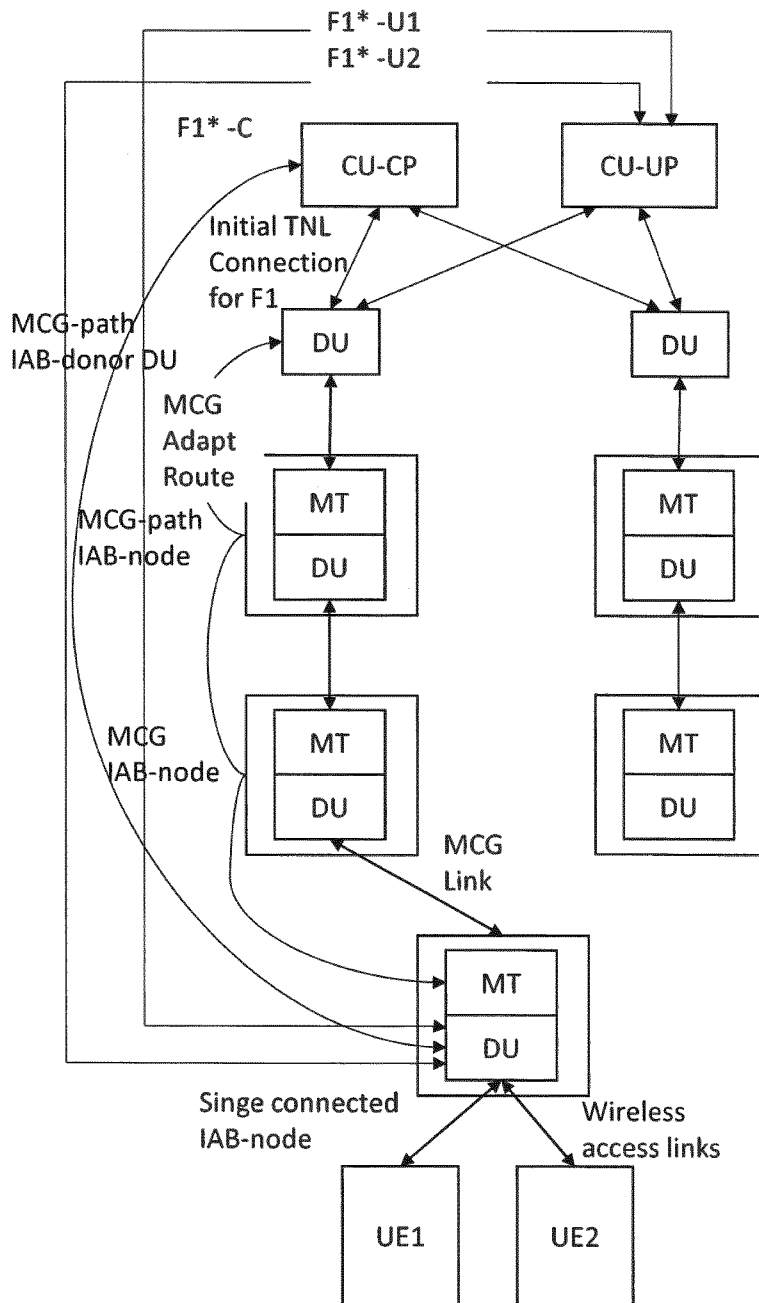

Fig. 5(a)

6/16

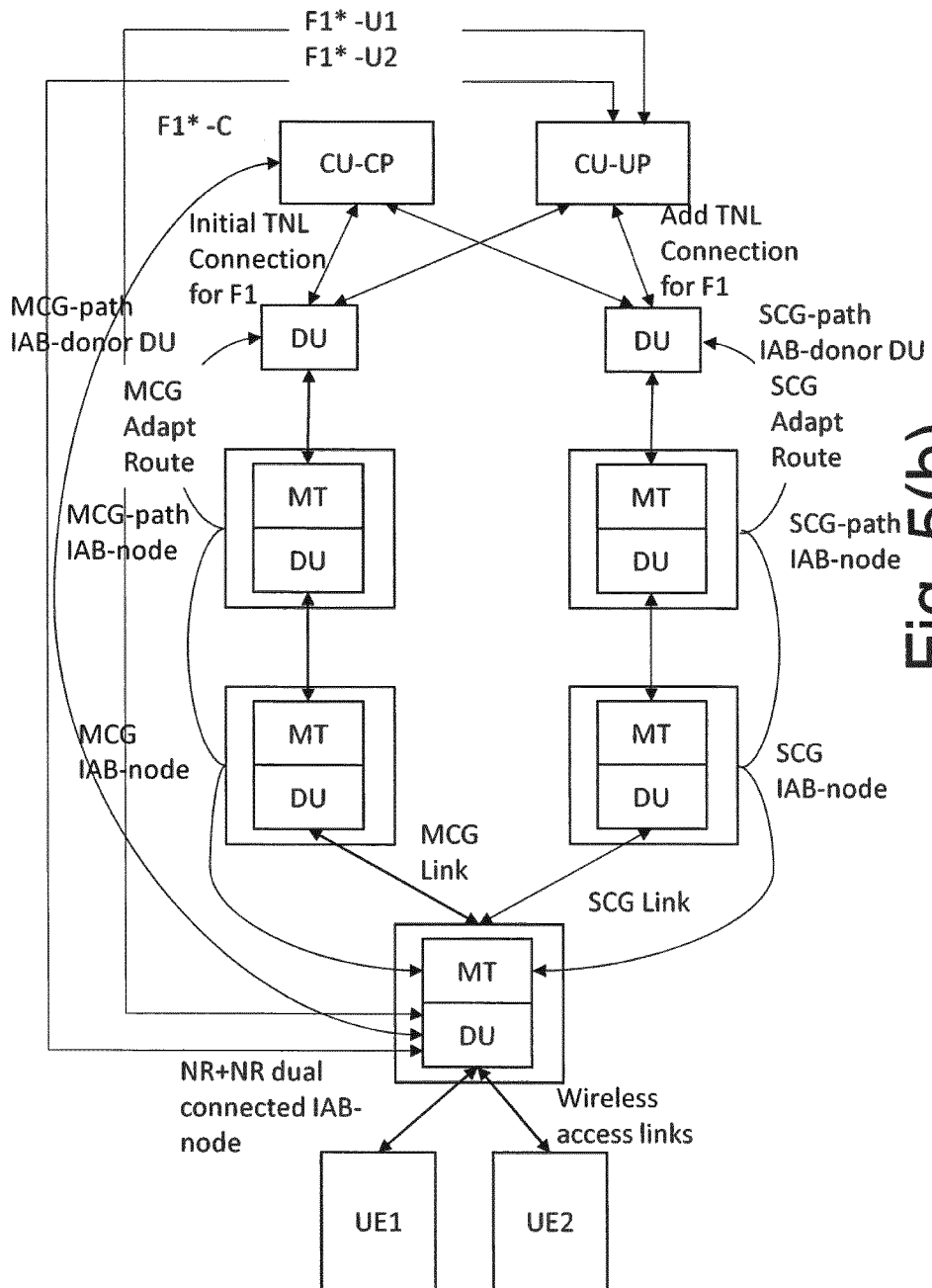

Fig. 5(b)

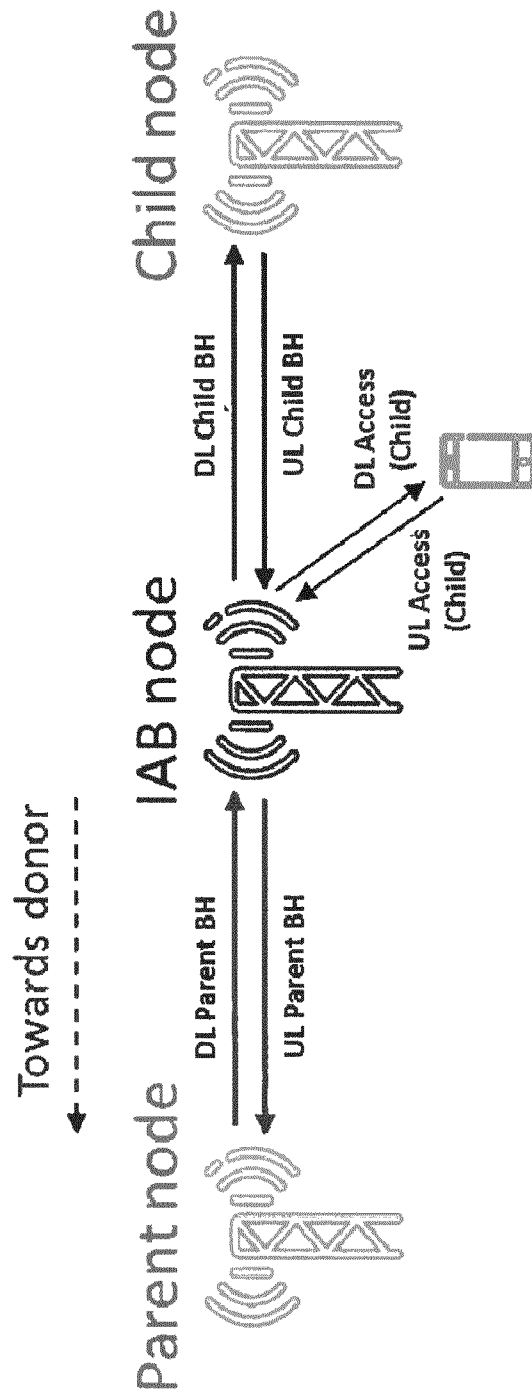

Fig. 6

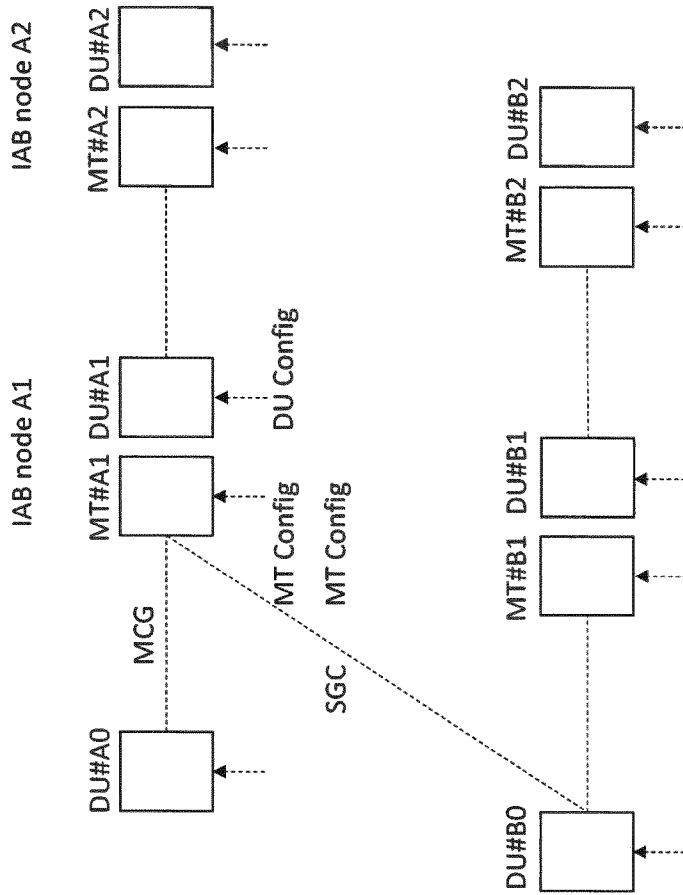

Fig. 7

MCG MT	SCG MT			Flex
	DL	UL	Flex	
DL	MCG -> DL	MCG -> DL	MCG -> DL	MCG -> DL
UL	MCG -> UL	MCG -> UL	MCG -> UL	MCG -> UL
Flex	SCG -> DL	SCG -> UL	SCG -> UL	MCG -> Flex

Fig. 8

MCG MT	SCG MT		
	DL	UL	Flex
DL	Both -> DL	MCG -> DL	MCG -> DL
UL	MCG -> UL	Both -> UL	MCG -> UL
Flex	MCG -> Flex	MCG -> Flex	MCG -> Flex

Fig. 9

MCG MT	SCG MT		
	DL	UL	Flex
DL	Both -> DL	MCG -> DL	MCG -> DL
UL	MCG -> UL	Both -> UL	MCG -> UL
Flex	SCG -> DL	SCG -> UL	MCG -> Flex

Fig. 10

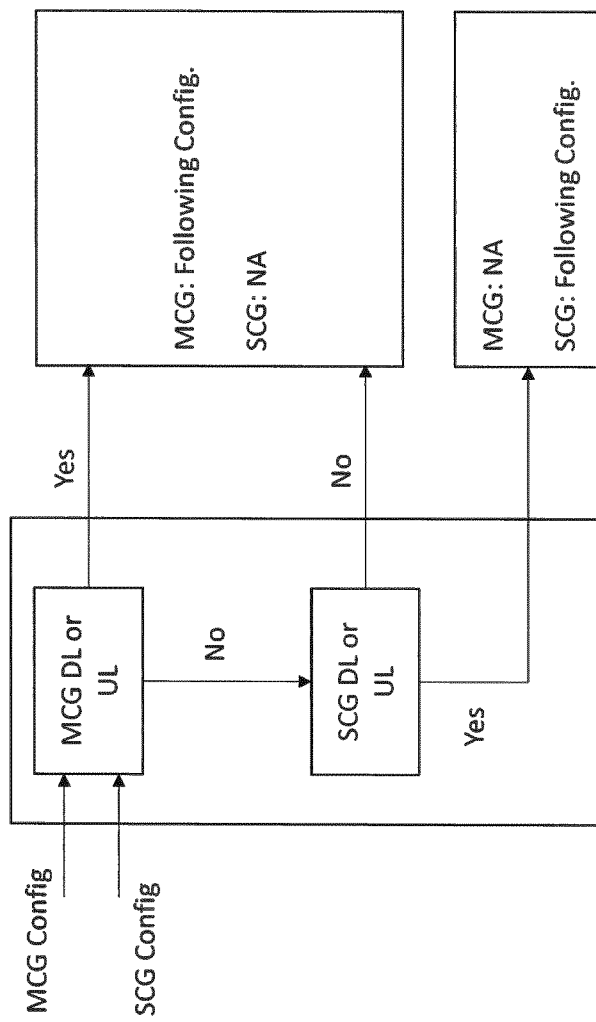

Fig. 11

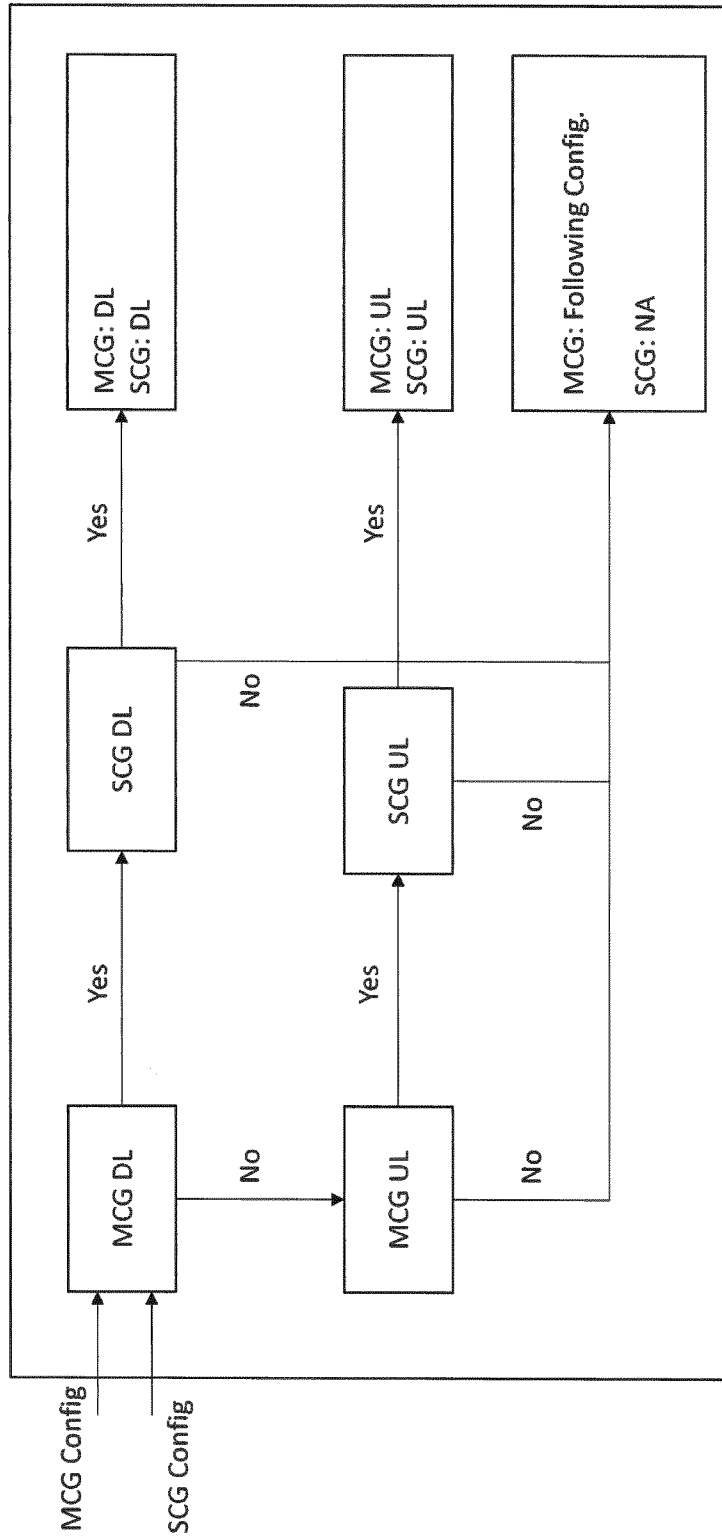

Fig. 12

14/16

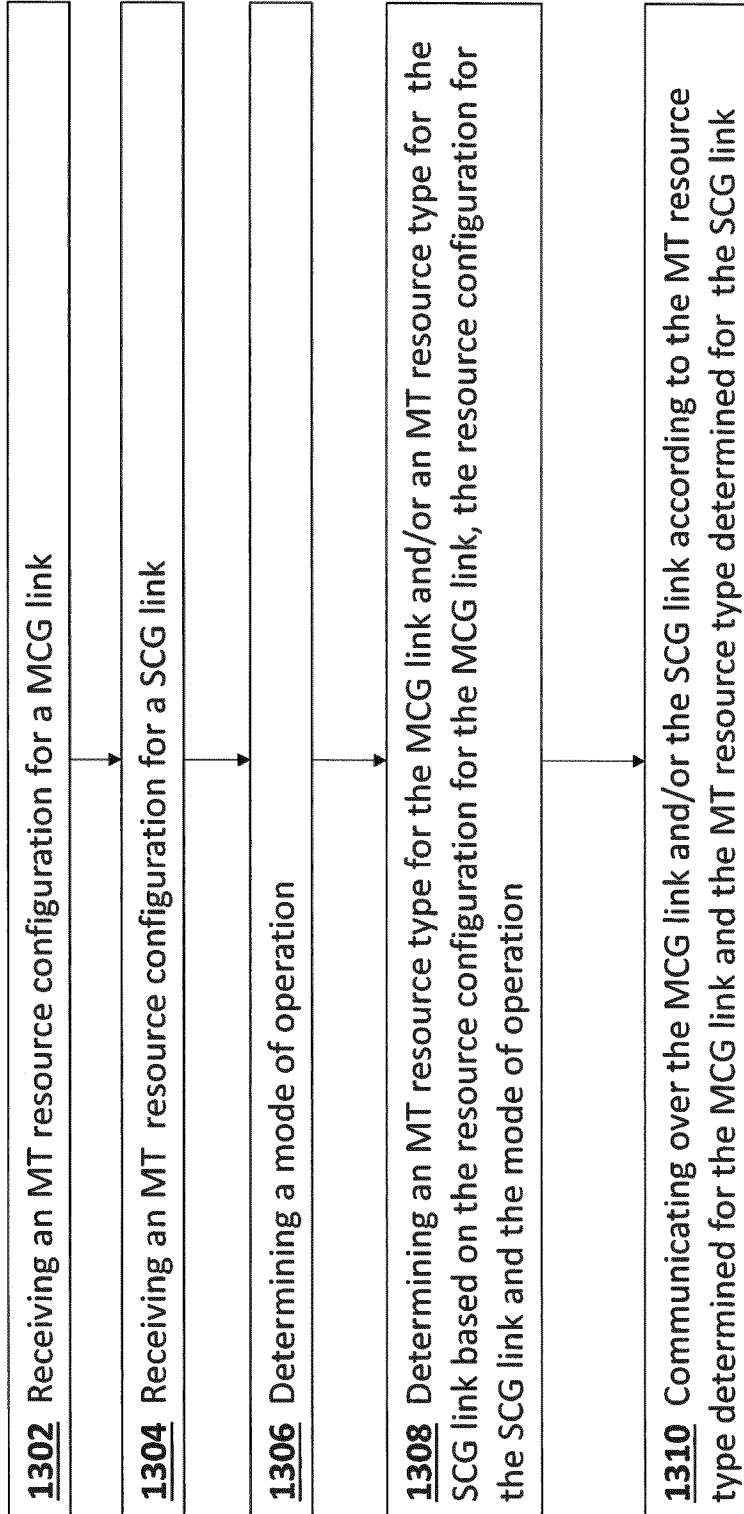

Fig. 13

15/16

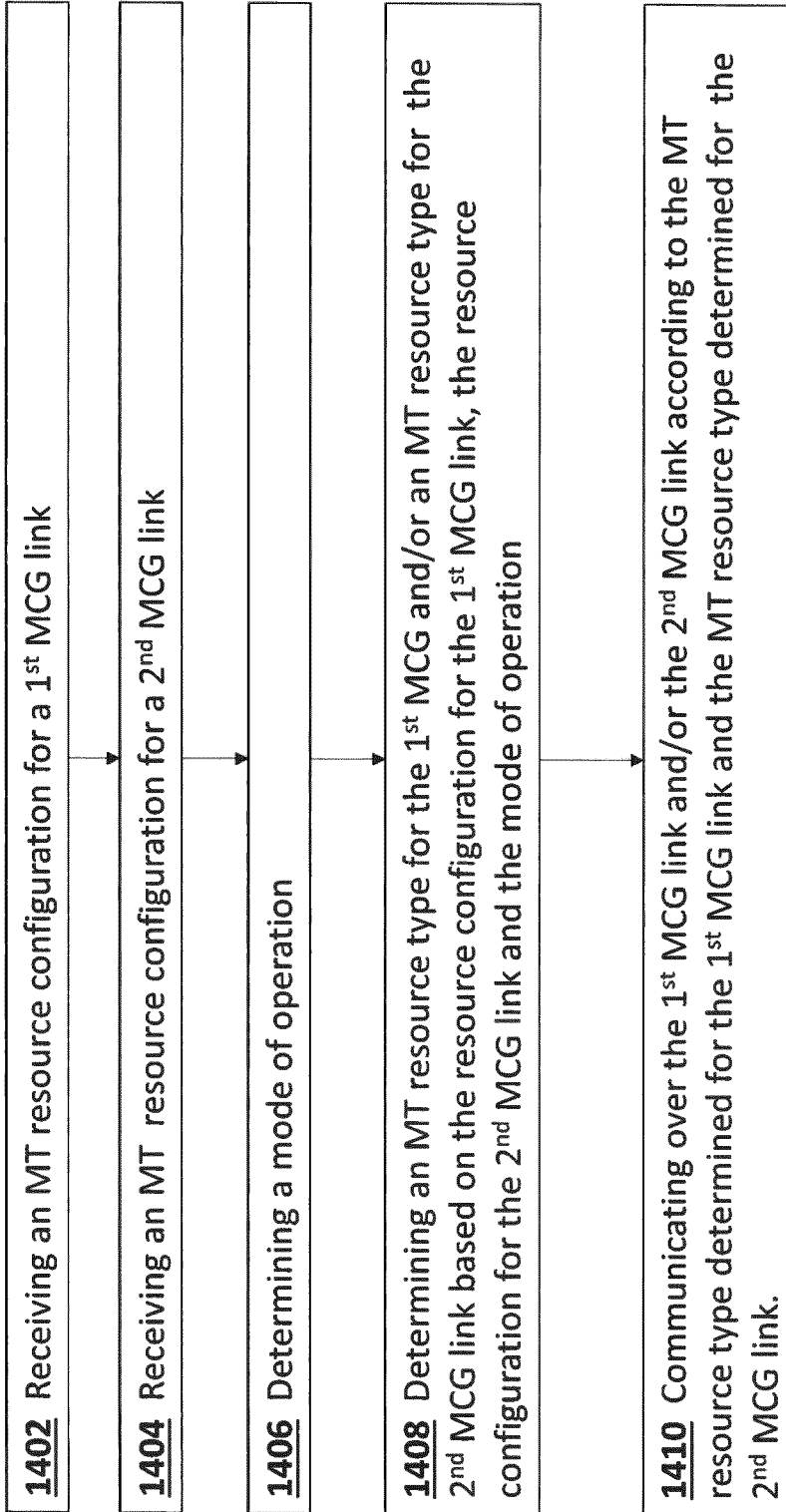

Fig. 14

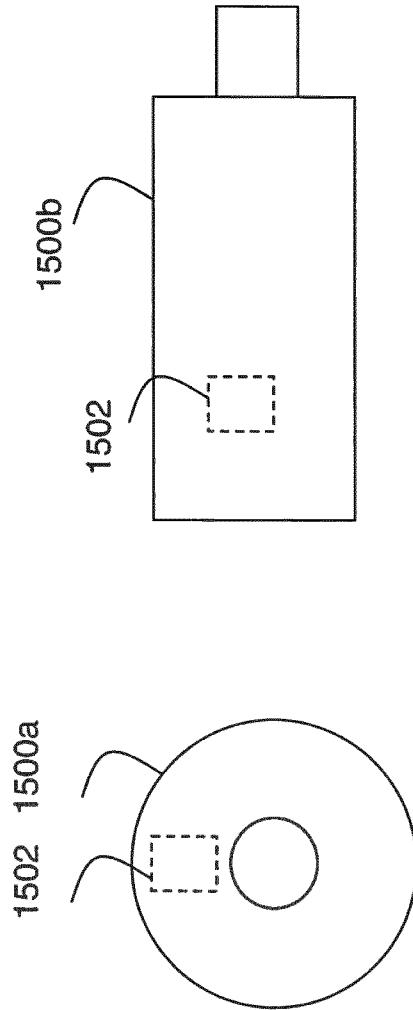

Fig. 15

INTERNATIONAL SEARCH REPORT

International application No
PCT/EP2019/054127

A. CLASSIFICATION OF SUBJECT MATTER
INV. H04W72/04
ADD. H04W28/08 H04W40/24

According to International Patent Classification (IPC) or to both national classification and IPC

B. FIELDS SEARCHED

Minimum documentation searched (classification system followed by classification symbols)
H04W

Documentation searched other than minimum documentation to the extent that such documents are included in the fields searched

Electronic data base consulted during the international search (name of data base and, where practicable, search terms used)
EPO-Internal

C. DOCUMENTS CONSIDERED TO BE RELEVANT

Category*	Citation of document, with indication, where appropriate, of the relevant passages	Relevant to claim No.
X	LG ELECTRONICS: "Discussions on mechanisms to support NR IAB scenarios", 3GPP DRAFT; R1-1810273 DISCUSSIONS ON NR IAB SUPPORT V0, 3RD GENERATION PARTNERSHIP PROJECT (3GPP), MOBILE COMPETENCE CENTRE ; 650, ROUTE DES LUCIOLES ; F-06921 SOPHIA-ANTIPOLIS CEDEX ; FRANCE vol. RAN WG1, no. Chengdu, China; 20181008 - 20181012 29 September 2018 (2018-09-29), XP051517687, Retrieved from the Internet: URL: http://www.3gpp.org/ftp/tsg%5Fran/WG1%5FRL1/TSGR1%5F94b/Docs/R1%2D1810273%2Ezip [retrieved on 2018-09-29]	1-20,28, 29
A	the whole document ----- -/--	22-27

Further documents are listed in the continuation of Box C.

See patent family annex.

* Special categories of cited documents :

- "A" document defining the general state of the art which is not considered to be of particular relevance
- "E" earlier application or patent but published on or after the international filing date
- "L" document which may throw doubts on priority claim(s) or which is cited to establish the publication date of another citation or other special reason (as specified)
- "O" document referring to an oral disclosure, use, exhibition or other means
- "P" document published prior to the international filing date but later than the priority date claimed

- "T" later document published after the international filing date or priority date and not in conflict with the application but cited to understand the principle or theory underlying the invention
- "X" document of particular relevance; the claimed invention cannot be considered novel or cannot be considered to involve an inventive step when the document is taken alone
- "Y" document of particular relevance; the claimed invention cannot be considered to involve an inventive step when the document is combined with one or more other such documents, such combination being obvious to a person skilled in the art
- "&" document member of the same patent family

Date of the actual completion of the international search

7 October 2019

Date of mailing of the international search report

24/10/2019

Name and mailing address of the ISA/

European Patent Office, P.B. 5818 Patentlaan 2
NL - 2280 HV Rijswijk
Tel. (+31-70) 340-2040,
Fax: (+31-70) 340-3016

Authorized officer

Papanikolaou, Eleni

INTERNATIONAL SEARCH REPORT

International application No
PCT/EP2019/054127

C(Continuation). DOCUMENTS CONSIDERED TO BE RELEVANT		
Category*	Citation of document, with indication, where appropriate, of the relevant passages	Relevant to claim No.
X	<p>AT&T: "Enhancements to support NR backhaul links", 3GPP DRAFT; R1-1812859, 3RD GENERATION PARTNERSHIP PROJECT (3GPP), MOBILE COMPETENCE CENTRE ; 650, ROUTE DES LUCIOLES ; F-06921 SOPHIA-ANTIPOLIS CEDEX ; FRANCE</p> <p>, vol. RAN WG1, no. Chengdu, China; 20181008 - 20181012 11 November 2018 (2018-11-11), XP051554822, Retrieved from the Internet: URL:http://www.3gpp.org/ftp/Meetings%5F3GP%5FSYNC/RAN1/Docs/R1%2D1812859%2Ezip [retrieved on 2018-11-11] the whole document</p> <p style="text-align: center;">-----</p>	1-29
X	<p>LG ELECTRONICS: "Discussions on NR IAB support", 3GPP DRAFT; R1-1804583 DISCUSSIONS ON IAB SUPPORT V03, 3RD GENERATION PARTNERSHIP PROJECT (3GPP), MOBILE COMPETENCE CENTRE ; 650, ROUTE DES LUCIOLES ; F-06921 SOPHIA-ANTIPOLIS CEDEX ; FRANCE</p> <p>, vol. RAN WG1, no. Sanya, China; 20180416 - 20180420 15 April 2018 (2018-04-15), XP051426851, Retrieved from the Internet: URL:http://www.3gpp.org/ftp/Meetings%5F3GP%5FSYNC/RAN1/Docs/ [retrieved on 2018-04-15] pages 1-7</p> <p style="text-align: center;">-----</p>	1,3-6, 28,29
A	<p>QUALCOMM INCORPORATED: "Resource Coordination across IAB Topology", 3GPP DRAFT; R2-1804865 RESOURCE COORDINATION ACROSS IAB TOPOLOGY, 3RD GENERATION PARTNERSHIP PROJECT (3GPP), MOBILE COMPETENCE CENTRE ; 650, ROUTE DES LUCIOLES ; F-06921 SOPHIA-ANTIPOLIS CEDEX ; FRANC</p> <p>, vol. RAN WG2, no. Sanya, CHINA; 20180416 - 20180420 14 April 2018 (2018-04-14), XP051428569, Retrieved from the Internet: URL:http://www.3gpp.org/ftp/Meetings%5F3GP%5FSYNC/RAN2/Docs/ [retrieved on 2018-04-14] the whole document</p> <p style="text-align: center;">-----</p> <p style="text-align: center;">-/--</p>	2,7-27
A	<p>QUALCOMM INCORPORATED: "Resource Coordination across IAB Topology", 3GPP DRAFT; R2-1804865 RESOURCE COORDINATION ACROSS IAB TOPOLOGY, 3RD GENERATION PARTNERSHIP PROJECT (3GPP), MOBILE COMPETENCE CENTRE ; 650, ROUTE DES LUCIOLES ; F-06921 SOPHIA-ANTIPOLIS CEDEX ; FRANC</p> <p>, vol. RAN WG2, no. Sanya, CHINA; 20180416 - 20180420 14 April 2018 (2018-04-14), XP051428569, Retrieved from the Internet: URL:http://www.3gpp.org/ftp/Meetings%5F3GP%5FSYNC/RAN2/Docs/ [retrieved on 2018-04-14] the whole document</p> <p style="text-align: center;">-----</p> <p style="text-align: center;">-/--</p>	1-29

INTERNATIONAL SEARCH REPORT

International application No
PCT/EP2019/054127

C(Continuation). DOCUMENTS CONSIDERED TO BE RELEVANT		
Category*	Citation of document, with indication, where appropriate, of the relevant passages	Relevant to claim No.
A	<p>AT&T: "Multi-connectivity Architecture Design for IAB Arch. 1a", 3GPP DRAFT; R3-185153, 3RD GENERATION PARTNERSHIP PROJECT (3GPP), MOBILE COMPETENCE CENTRE ; 650, ROUTE DES LUCIOLES ; F-06921 SOPHIA-ANTIPOLIS CEDEX ; FRANCE</p> <p>, vol. RAN WG3, no. Gothenburg, Sweden; 20180820 - 20180824 28 August 2018 (2018-08-28), XP051528482, Retrieved from the Internet: URL:http://www.3gpp.org/ftp/tsg%5Fran/WG3%5FIu/TSGR3%5F101/Docs/R3%2D185153%2Ezip [retrieved on 2018-08-28] the whole document</p> <p style="text-align: center;">-----</p>	1-29