



US 20240085216A1

(19) **United States**

(12) **Patent Application Publication**

Yedid et al.

(10) **Pub. No.: US 2024/0085216 A1**

(43) **Pub. Date: Mar. 14, 2024**

(54) **OPTICAL-PATH FOLDING-ELEMENT WITH AN EXTENDED TWO DEGREE OF FREEDOM ROTATION RANGE**

(71) Applicant: **Corephotonics Ltd.**, Tel Aviv (IL)

(72) Inventors: **Itay Yedid**, Tel Aviv (IL); **Ephraim Goldenberg**, Tel Aviv (IL); **Gil Bachar**, Tel Aviv (IL); **Gal Barak**, Tel Aviv (IL); **Yiftah Kowal**, Tel Aviv (IL)

(21) Appl. No.: **18/509,353**

(22) Filed: **Nov. 15, 2023**

Related U.S. Application Data

(63) Continuation of application No. 18/337,005, filed on Jun. 18, 2023, now Pat. No. 11,867,535, which is a continuation of application No. 18/299,727, filed on Apr. 13, 2023, now Pat. No. 11,733,064, which is a continuation of application No. 17/984,355, filed on Nov. 10, 2022, now Pat. No. 11,650,080, which is a continuation of application No. 17/829,722, filed on Jun. 1, 2022, now Pat. No. 11,506,513, which is a continuation of application No. 17/013,561, filed on Sep. 5, 2020, now Pat. No. 11,359,937, which is a continuation of application No. 16/615,310, filed on Nov. 20, 2019, now Pat. No. 11,268,829, filed as application No. PCT/IB2019/053315 on Apr. 22, 2019.

(60) Provisional application No. 62/661,158, filed on Apr. 23, 2018.

Publication Classification

- (51) **Int. Cl.**
G01D 5/14 (2006.01)
G01P 13/00 (2006.01)
G02B 7/18 (2006.01)
G02B 7/182 (2006.01)
G02B 13/00 (2006.01)
G03B 17/17 (2006.01)
H01F 7/02 (2006.01)
H04N 23/45 (2006.01)
H04N 23/57 (2006.01)
H04N 23/58 (2006.01)
H04N 23/69 (2006.01)
H04N 23/698 (2006.01)
- (52) **U.S. Cl.**
 CPC *G01D 5/145* (2013.01); *G01P 13/00* (2013.01); *G02B 7/18* (2013.01); *G02B 7/1827* (2013.01); *G02B 13/0065* (2013.01); *G03B 17/17* (2013.01); *H01F 7/02* (2013.01); *H04N 23/45* (2023.01); *H04N 23/57* (2023.01); *H04N 23/58* (2023.01); *H04N 23/69* (2023.01); *H04N 23/698* (2023.01); *H04N 23/55* (2023.01)

(57) **ABSTRACT**

Actuators for rotating an optical-path-folding-element with two, first and second, degrees of freedom in an extended rotation range around two respective rotation axes, folded cameras including such actuators and dual-cameras including a folded camera as above together with an upright camera.

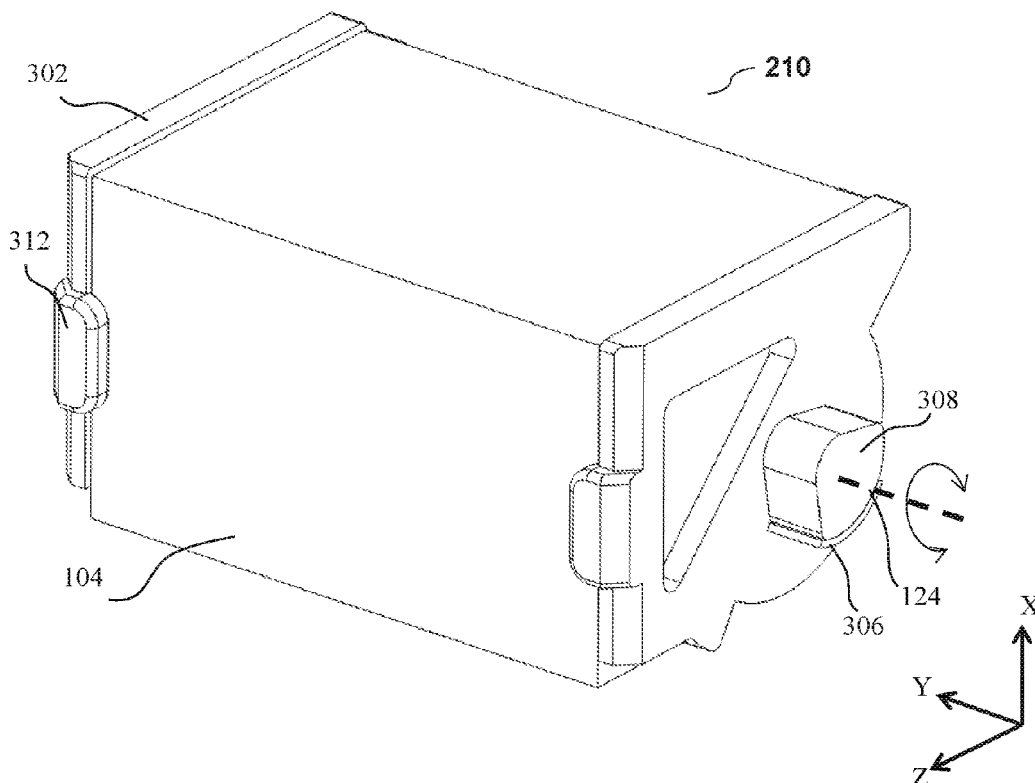

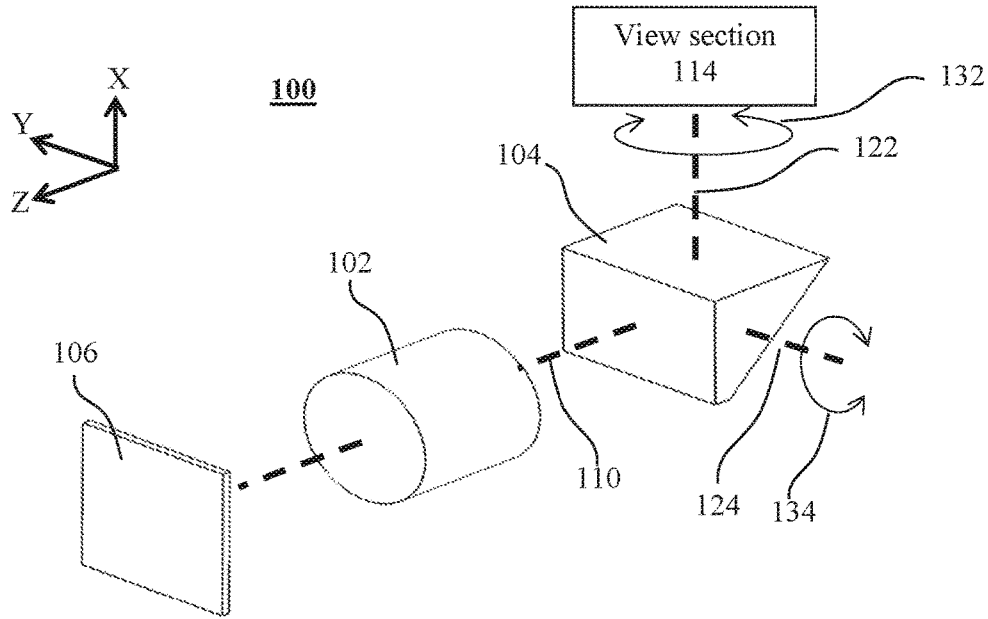

FIG. 1A

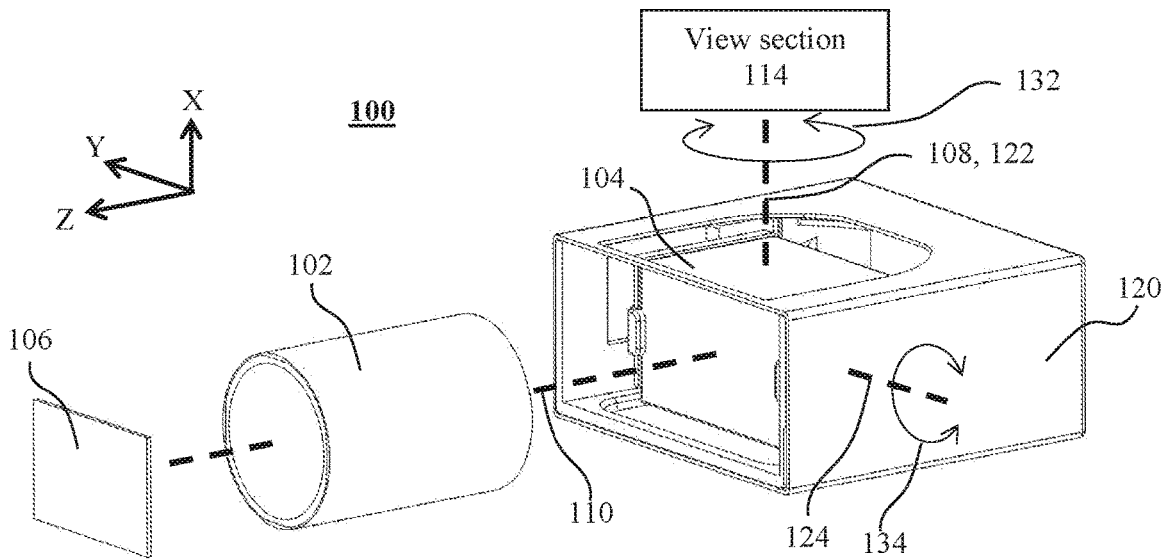

FIG. 1B

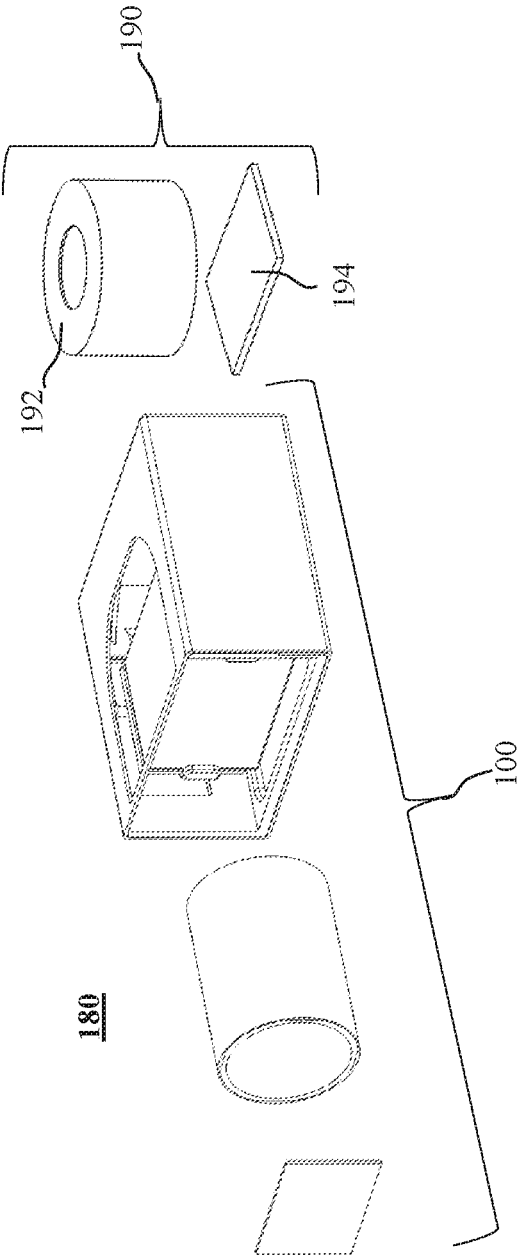

FIG. 1C

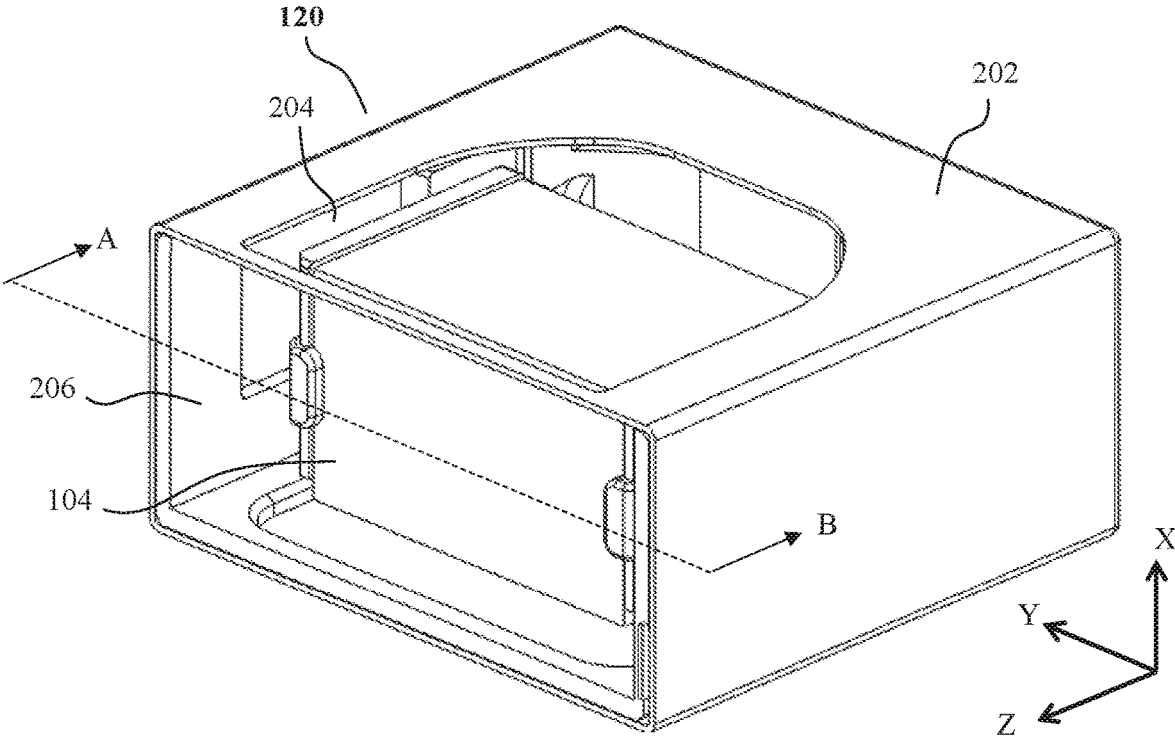
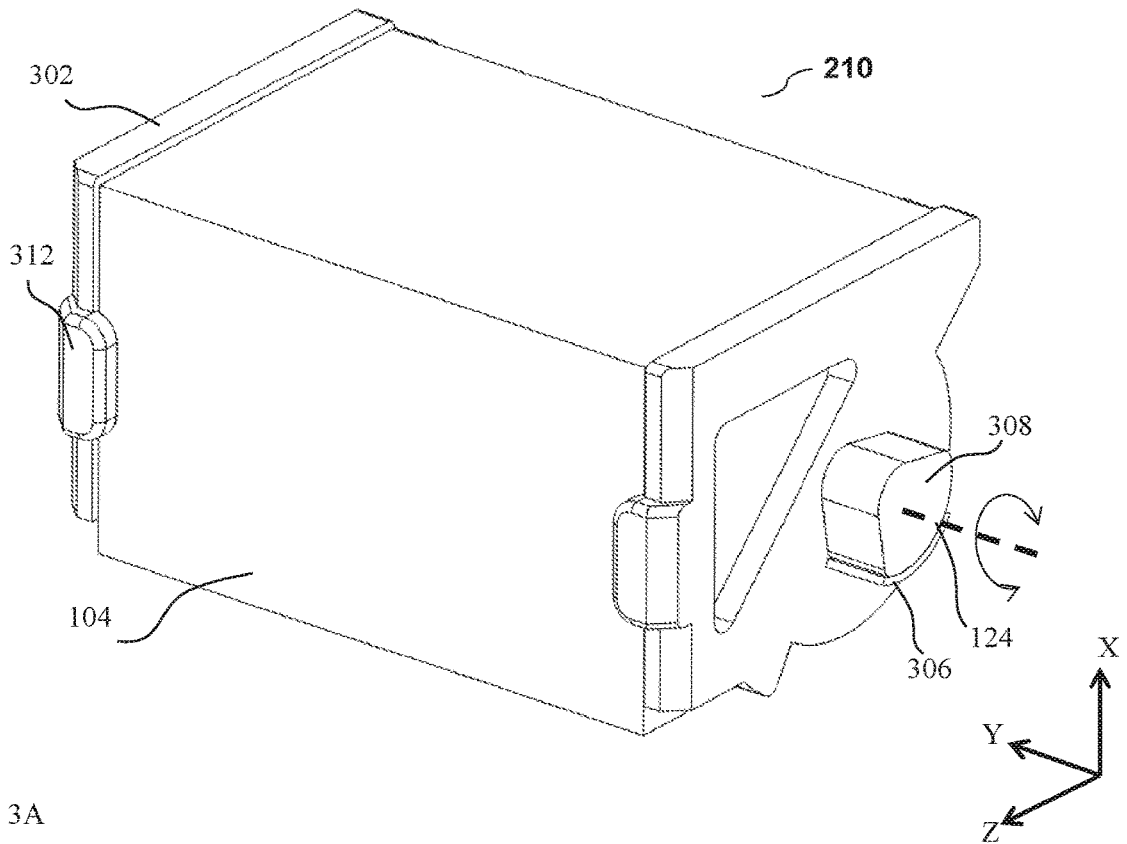
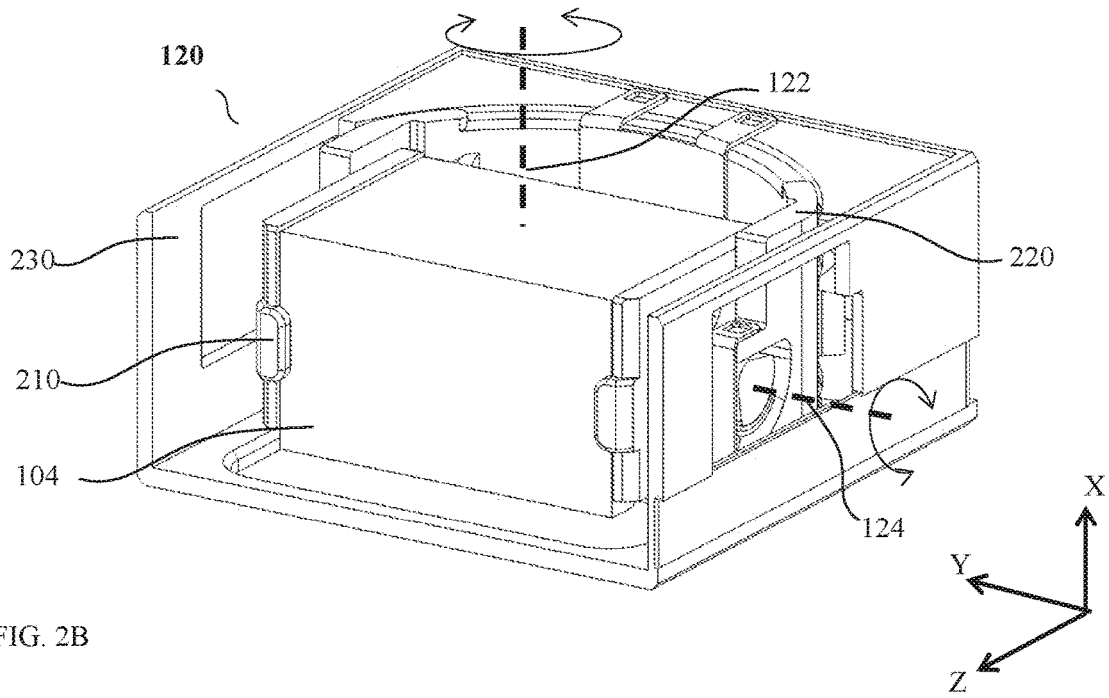

FIG. 2A



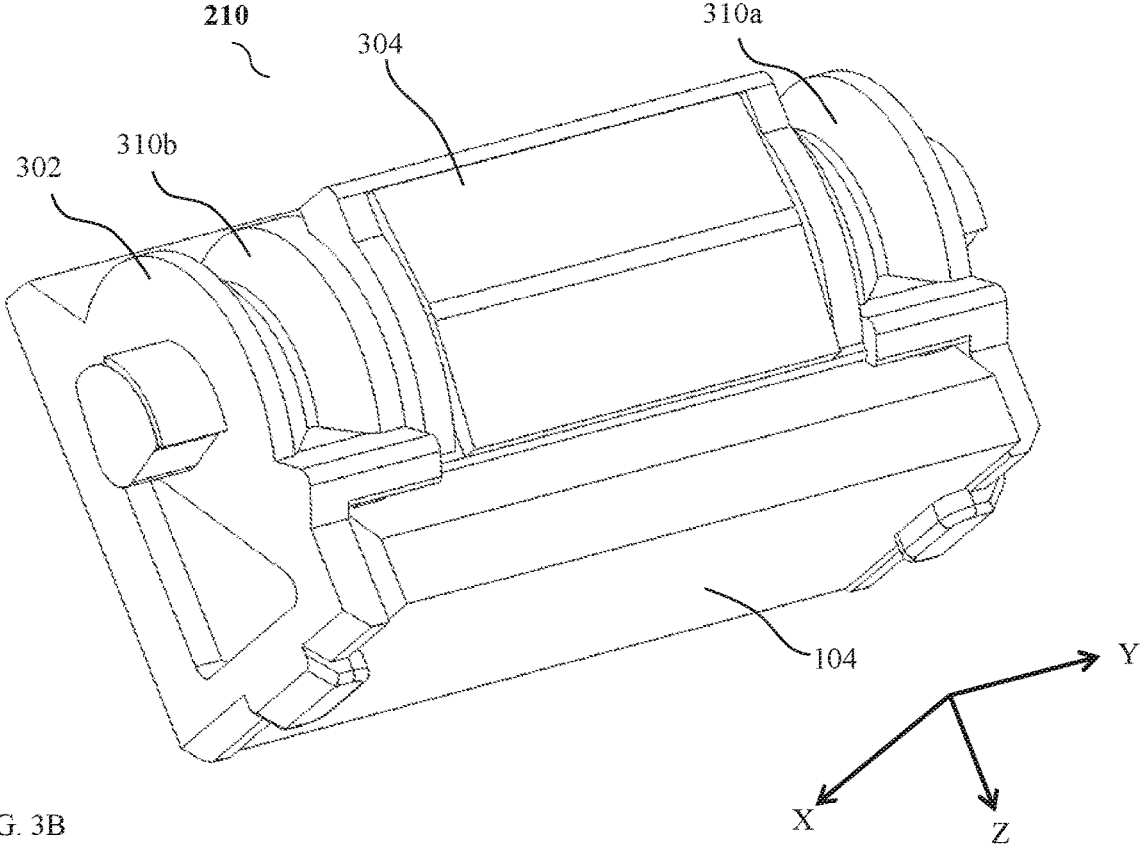

FIG. 3B

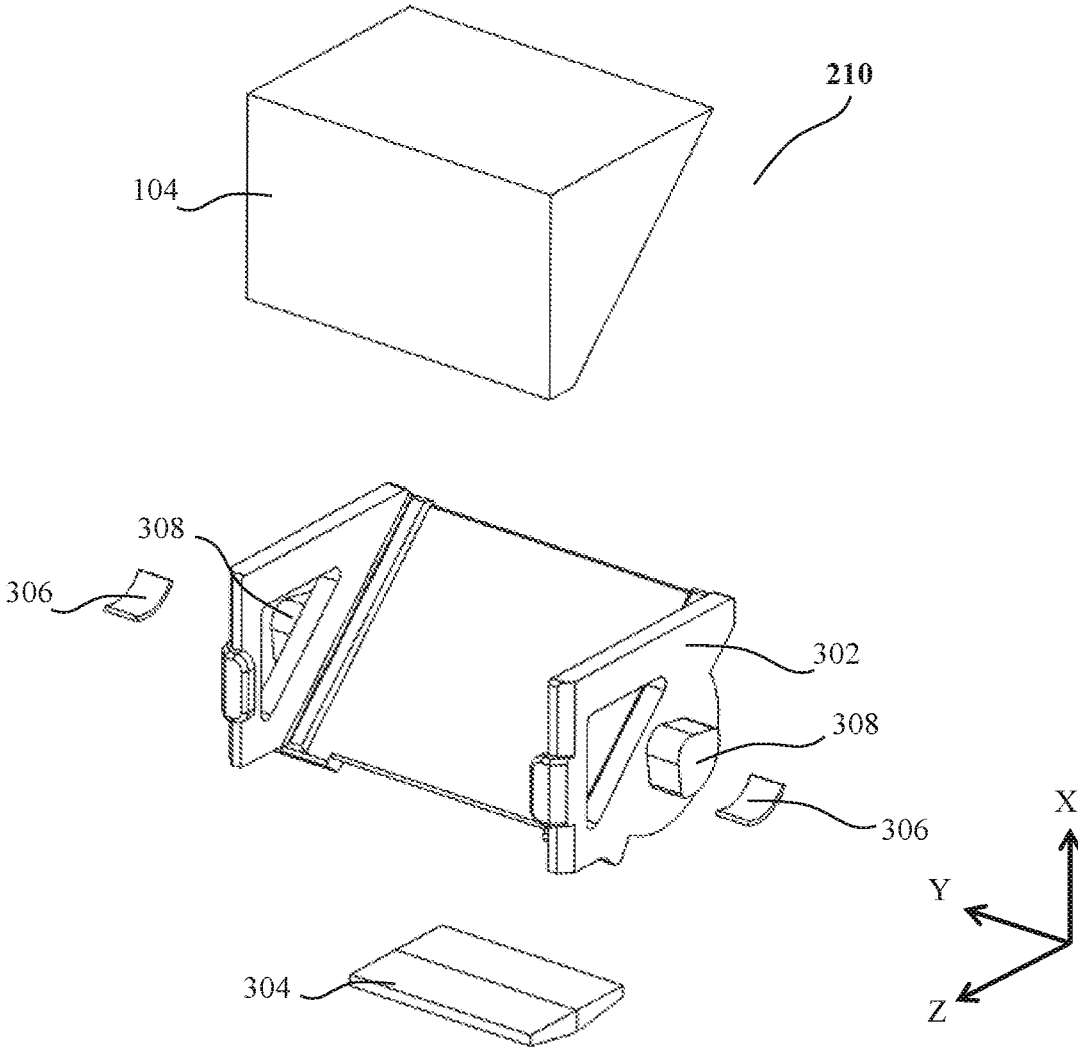

FIG. 3C

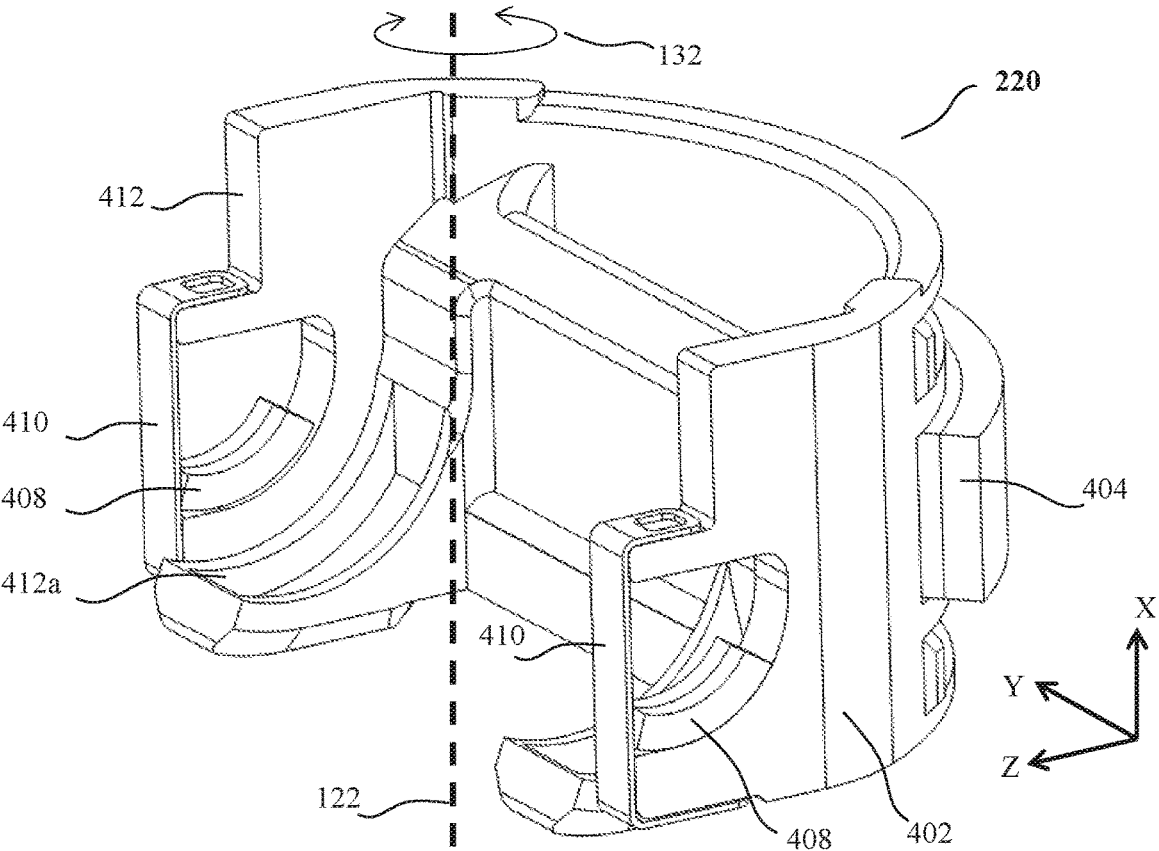

FIG. 4A

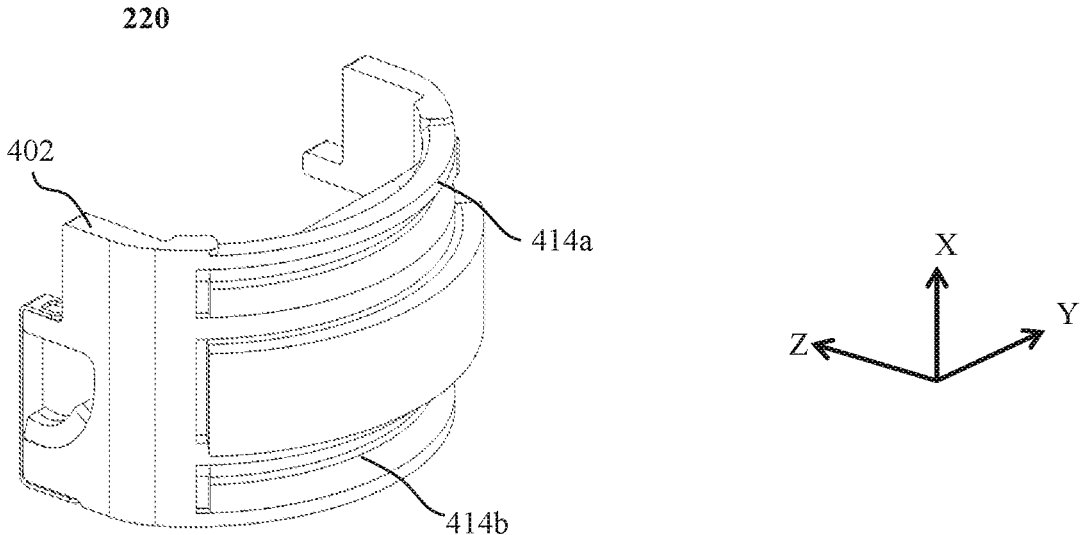

FIG. 4B

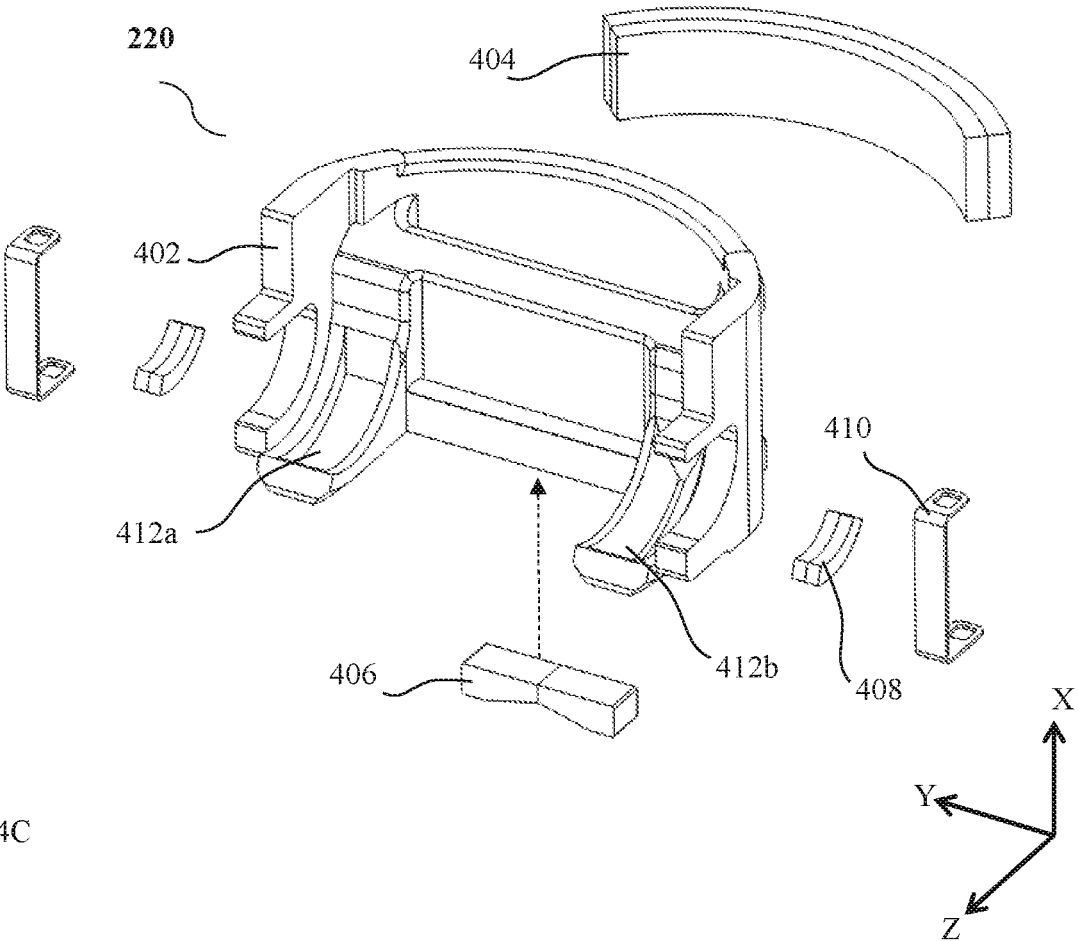

FIG. 4C

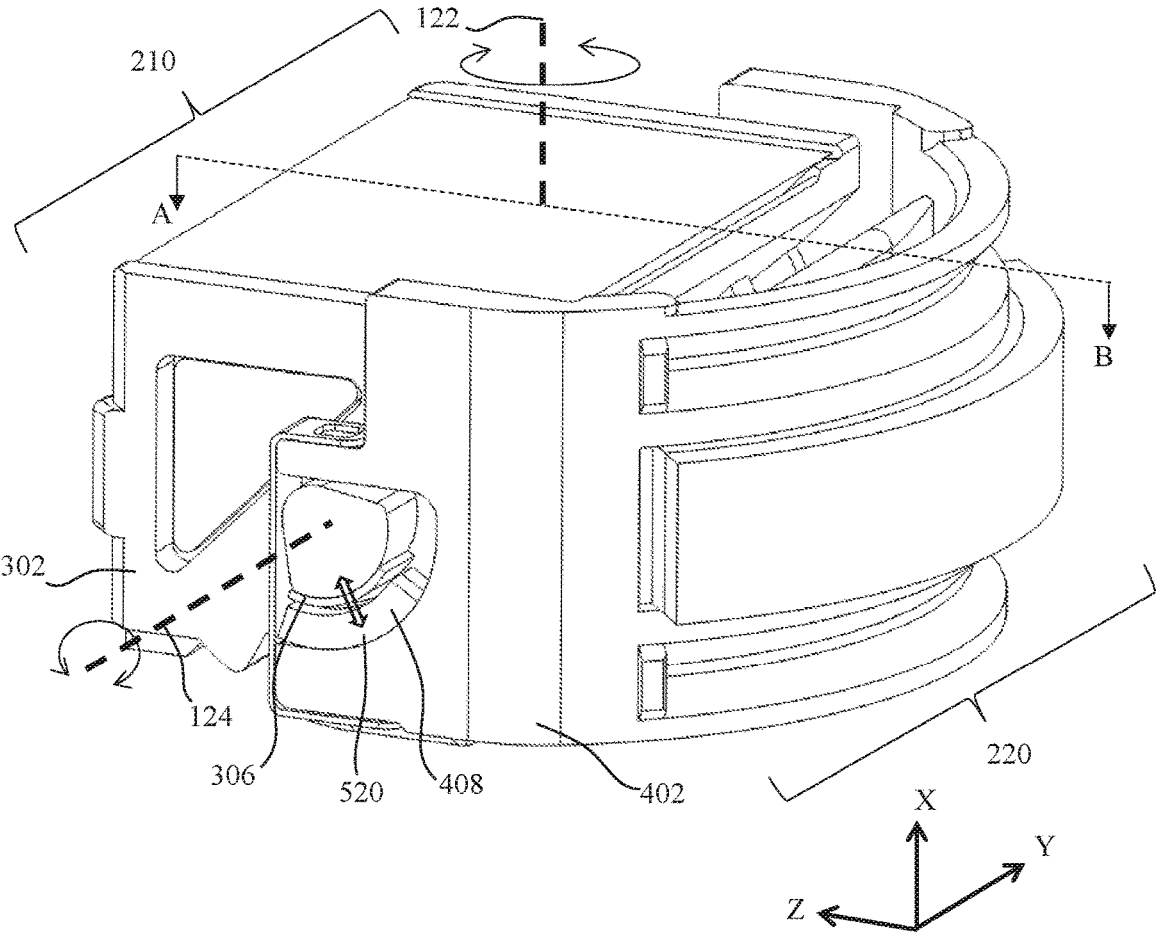

FIG. 5A

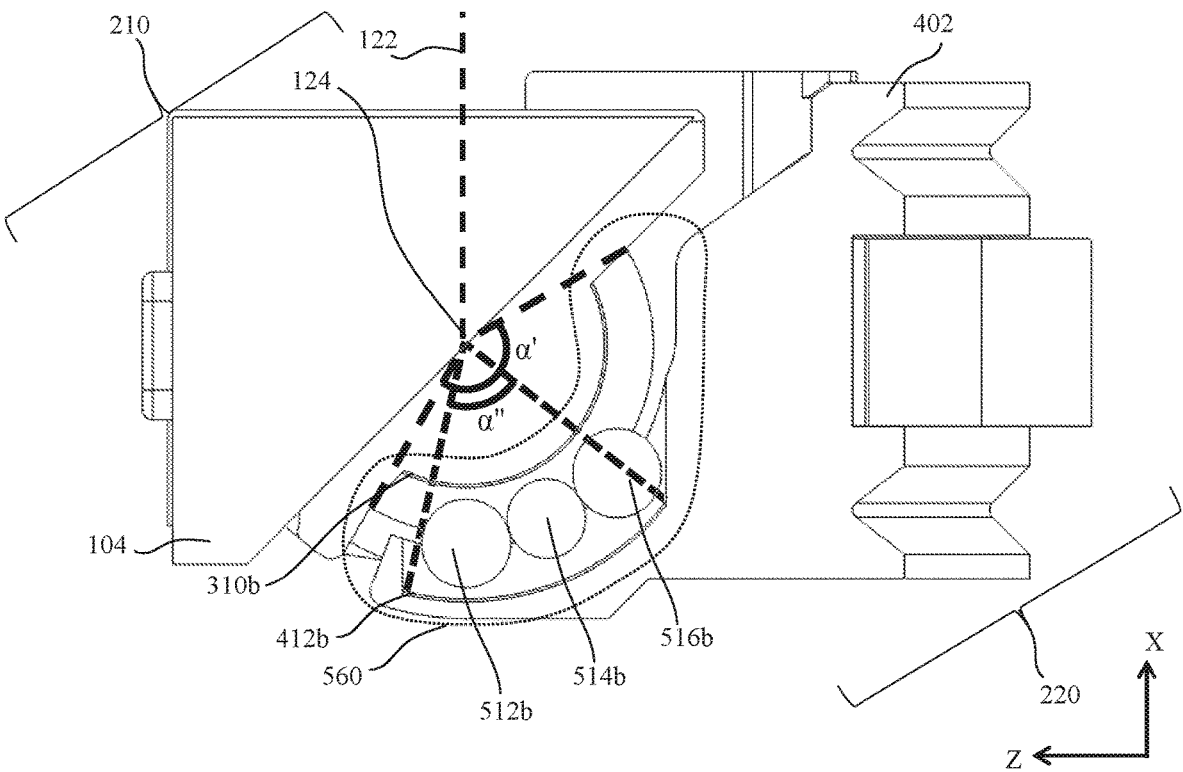

FIG. 5B

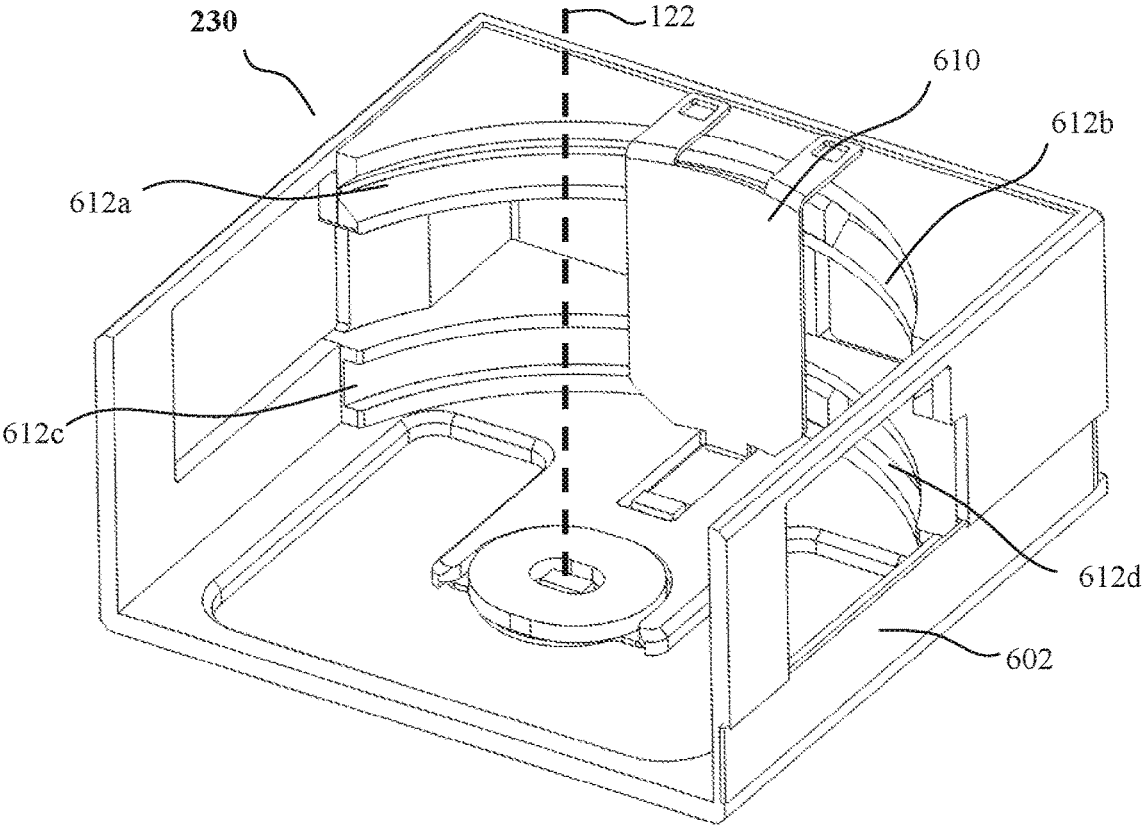

FIG. 6A

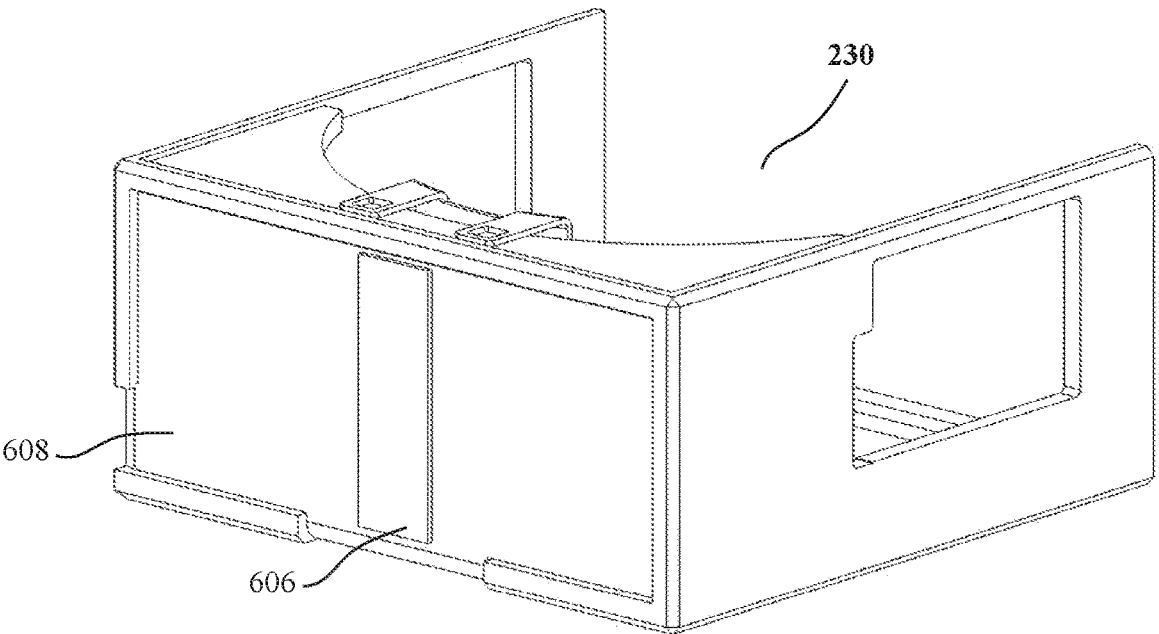

FIG. 6B

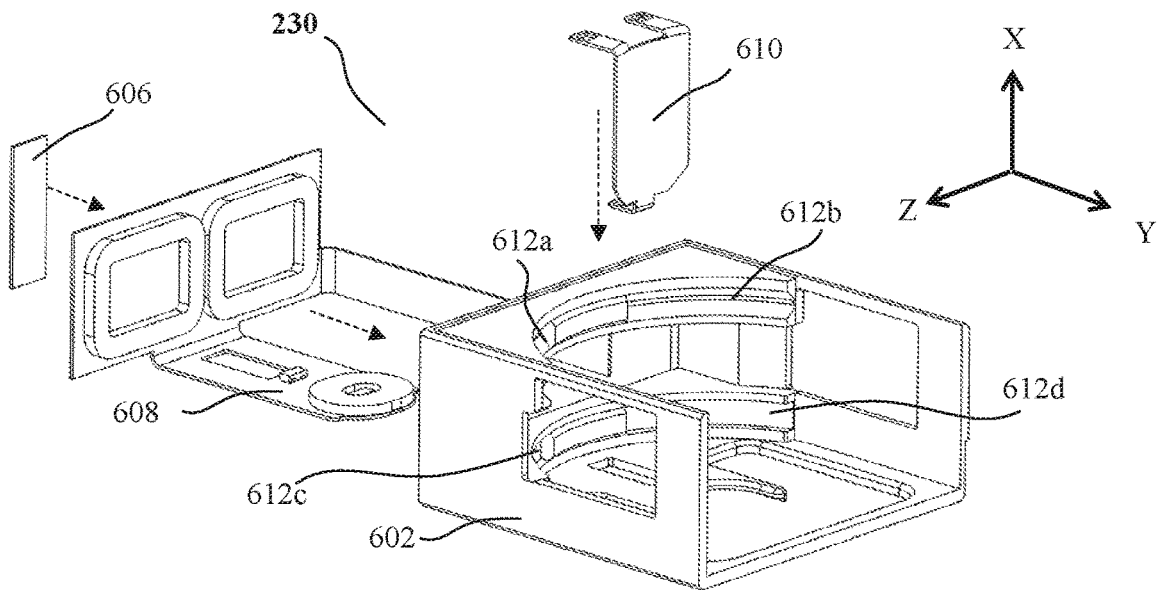

FIG. 6C

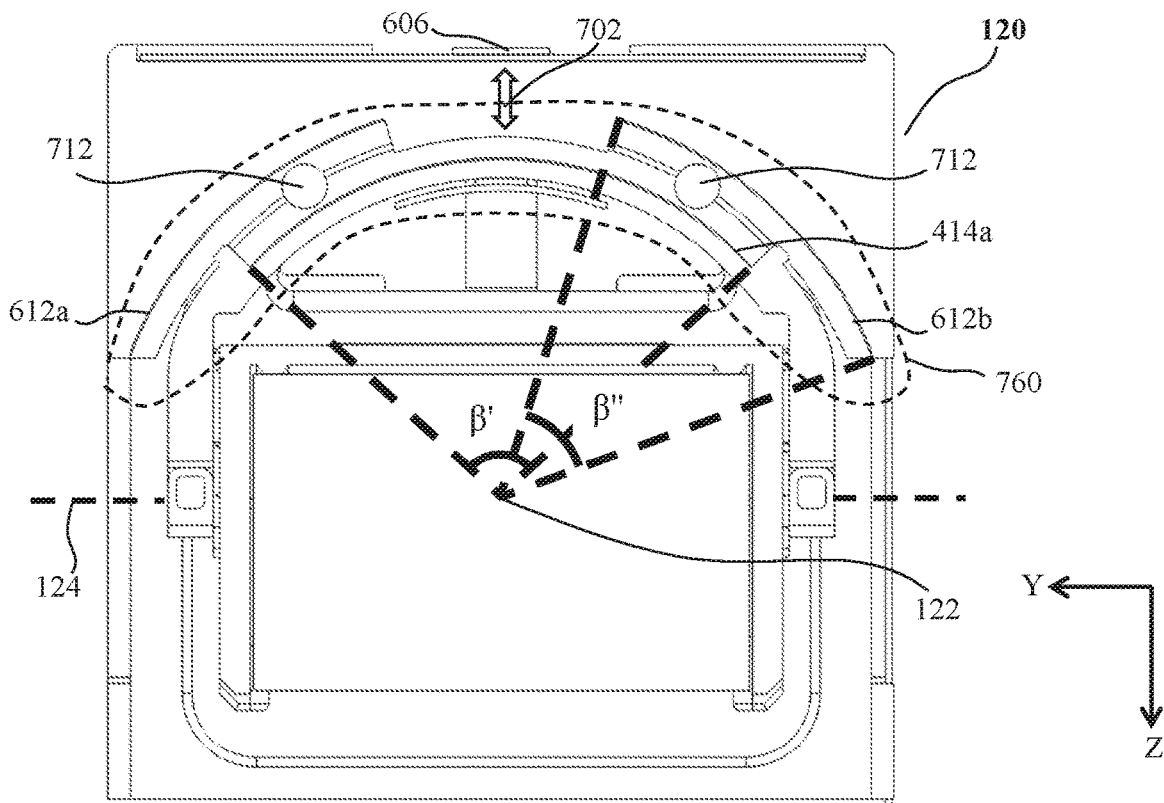

FIG. 7

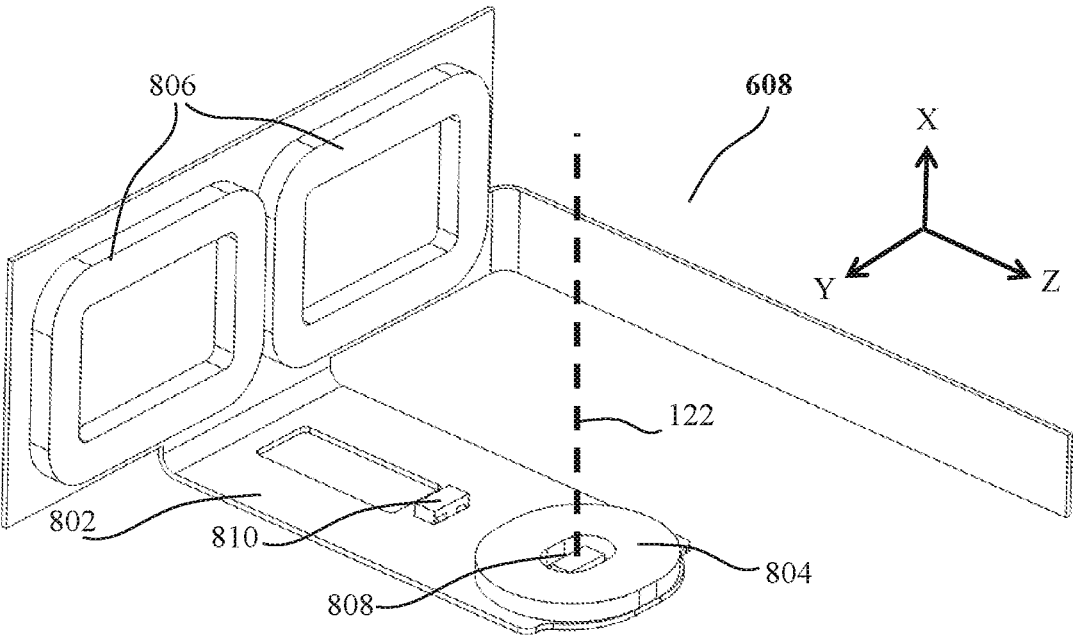

FIG. 8

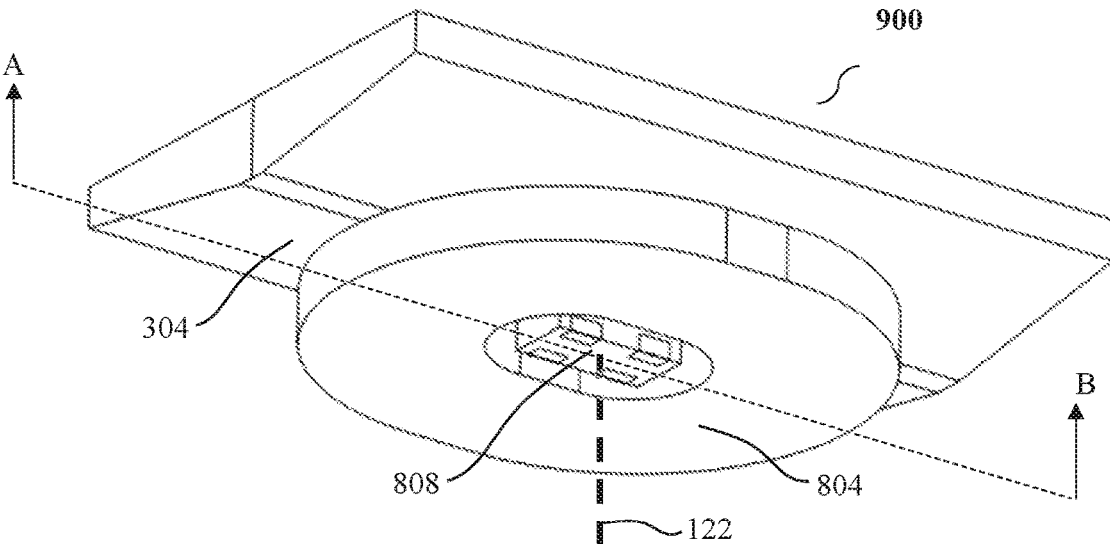

FIG. 9A

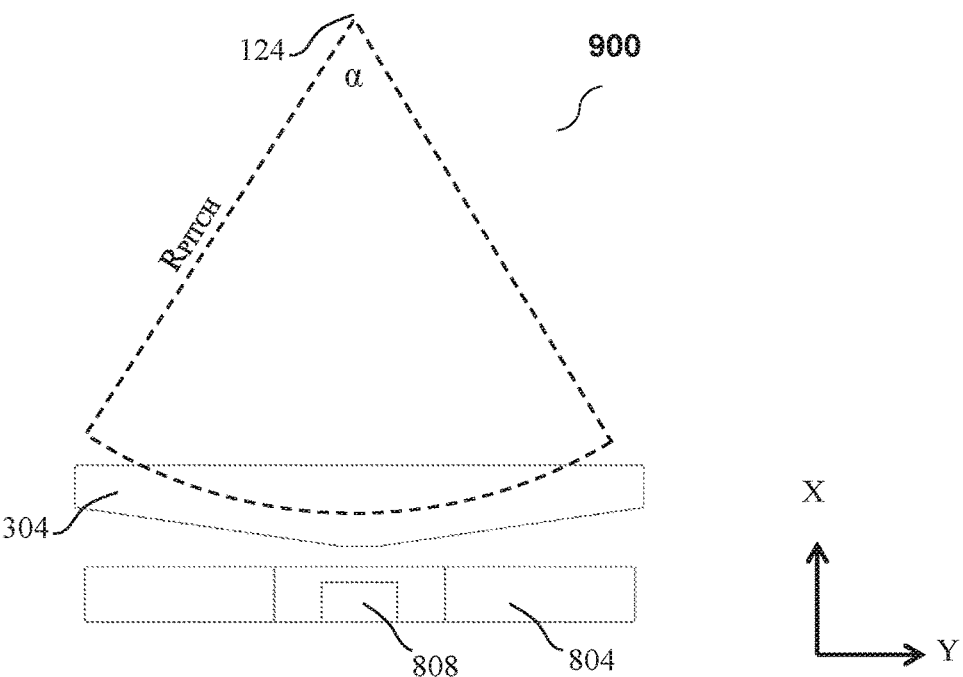

FIG. 9B

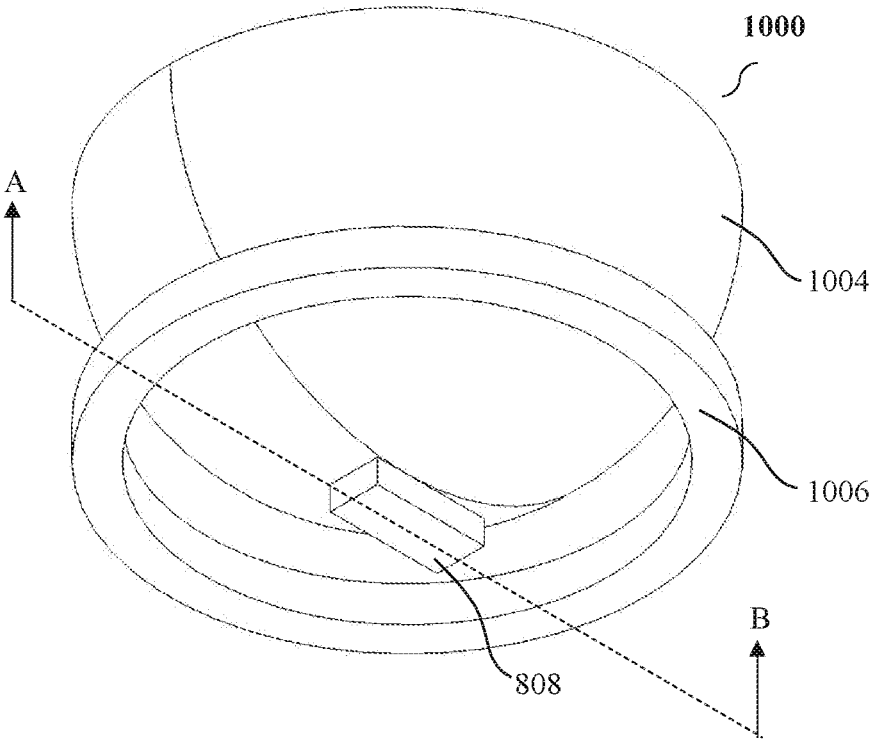

FIG. 10A

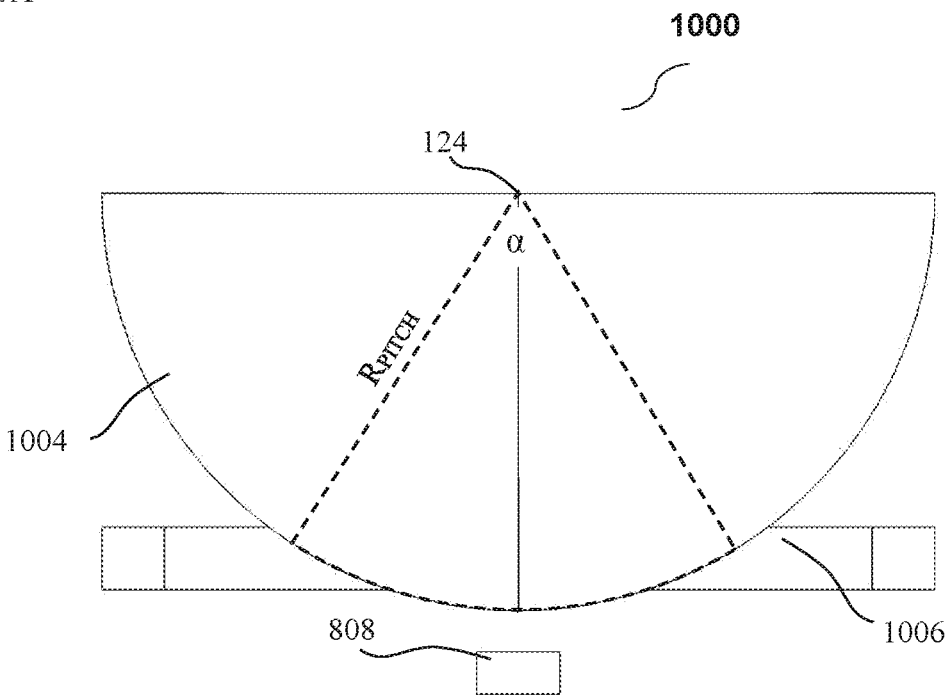

FIG. 10B

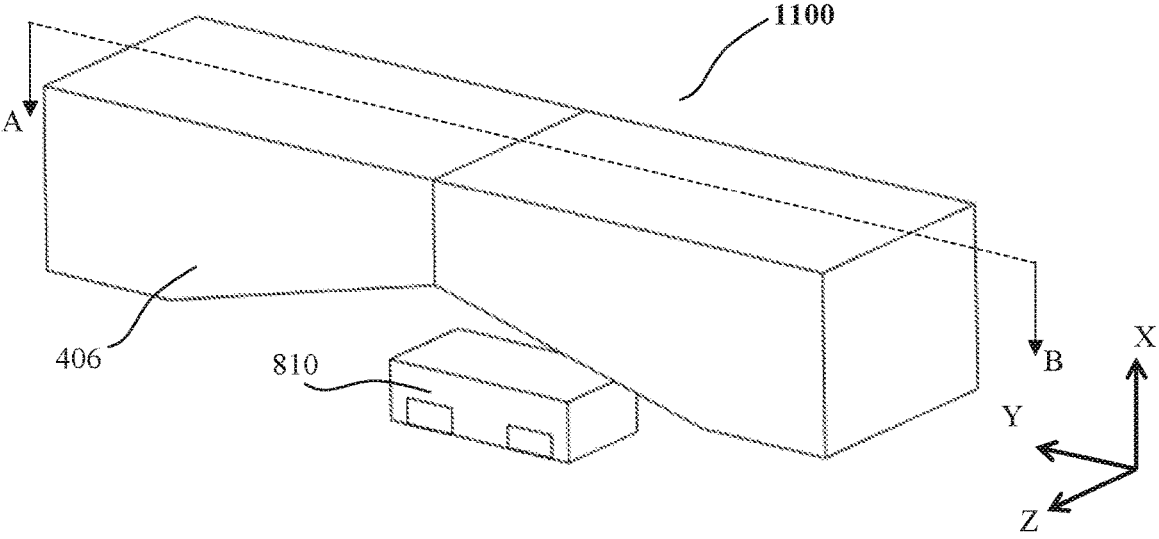

FIG. 11A

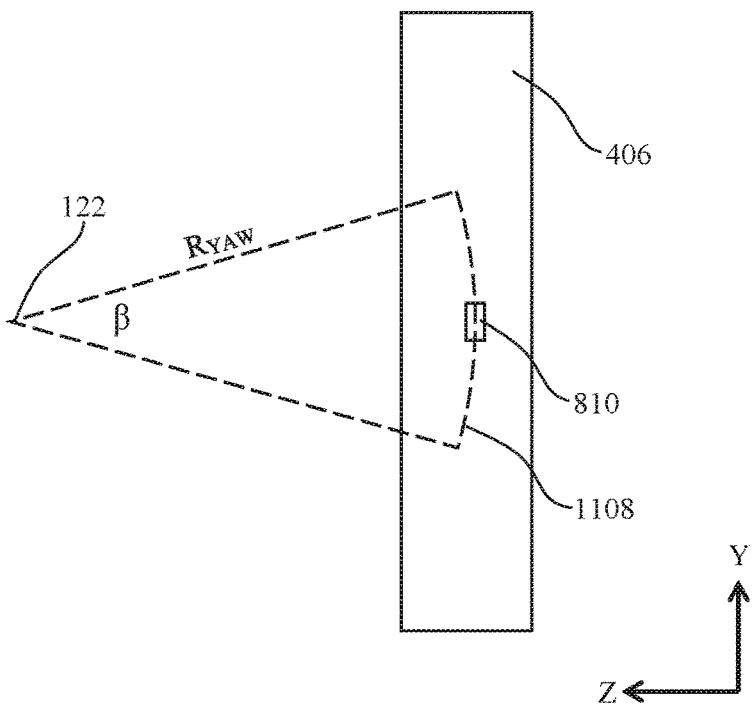

FIG. 11B

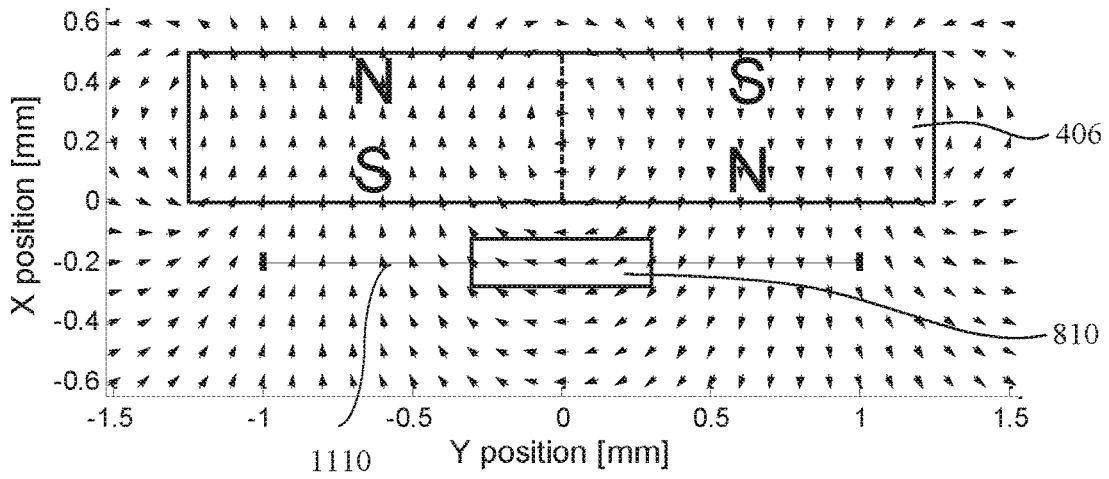

FIG. 11C

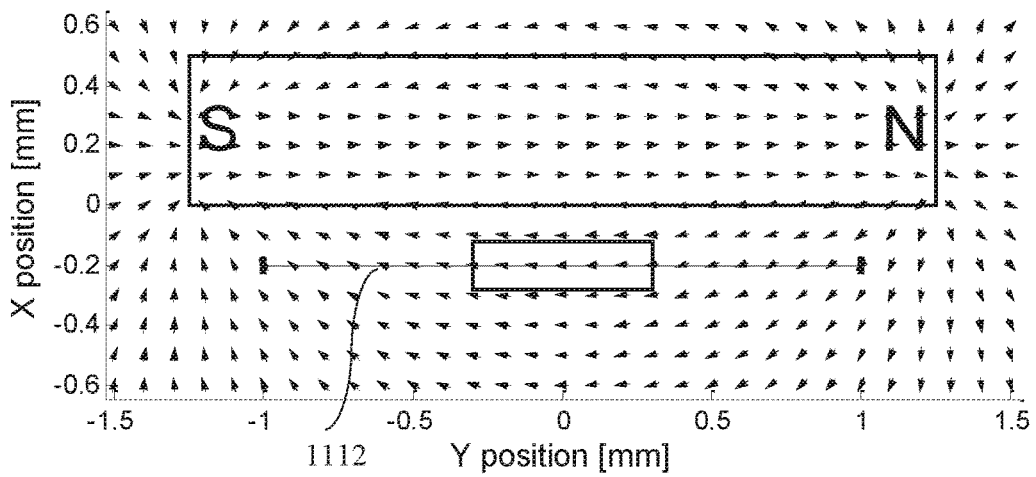

FIG. 11D

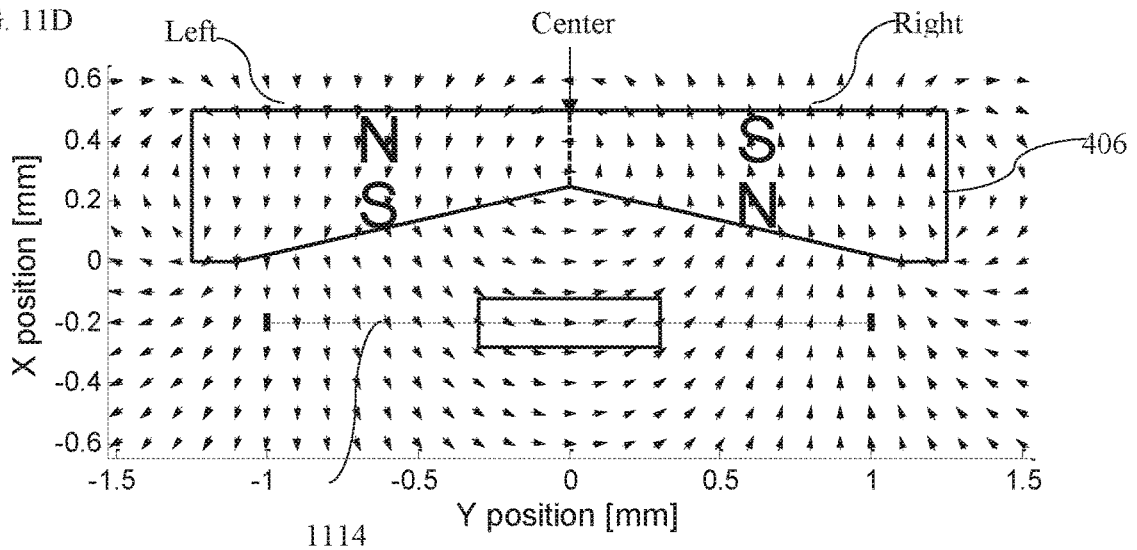

FIG. 11E

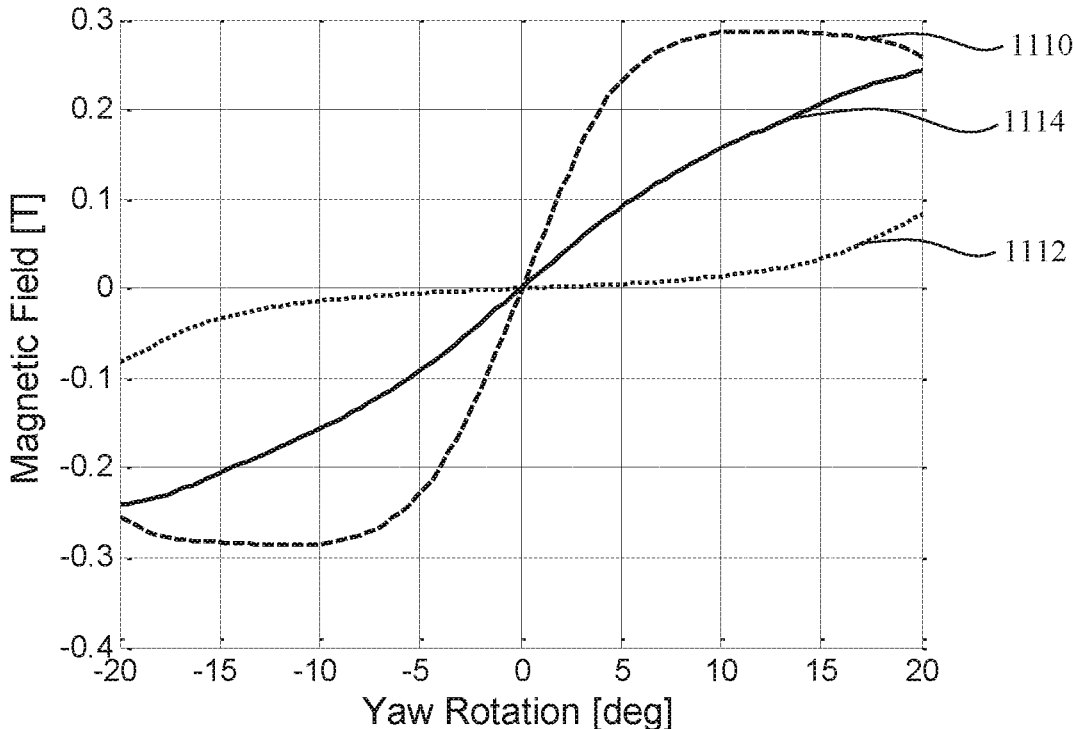

FIG. 11F

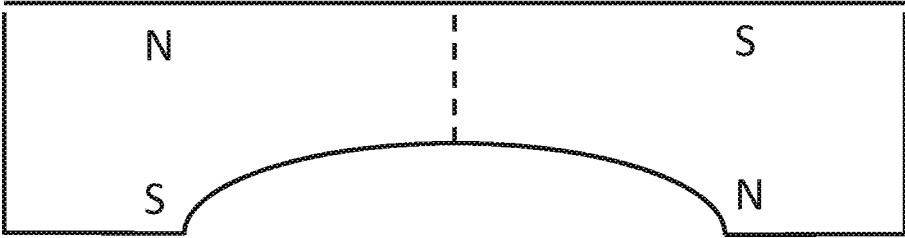

FIG. 11 - i

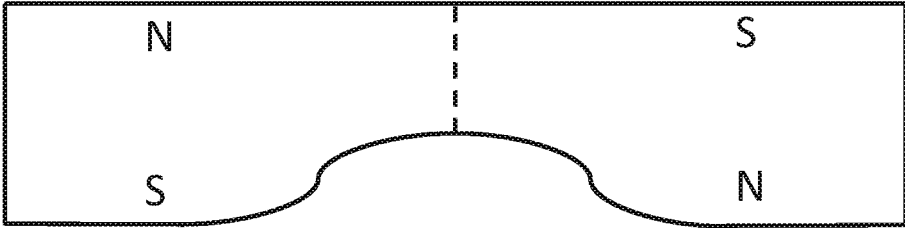

FIG. 11- ii

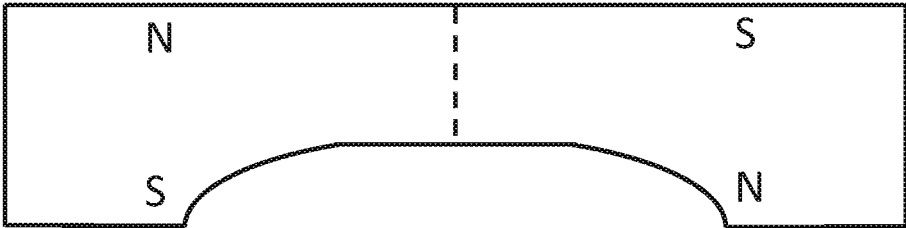

FIG. 11-iii

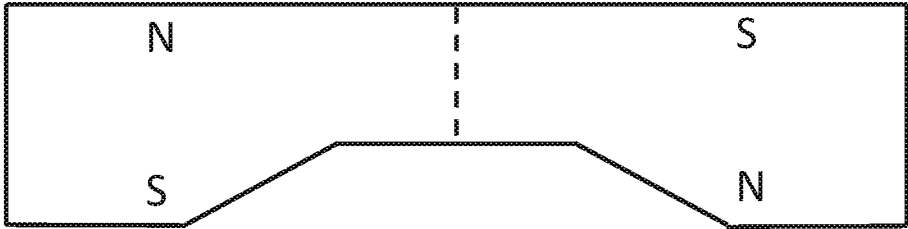

FIG. 11-iv

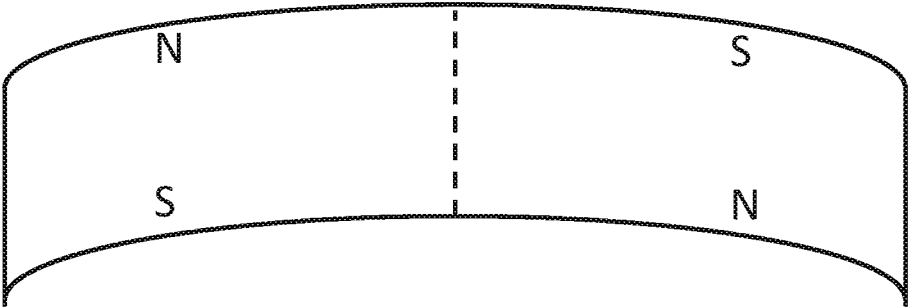

FIG. 11-v

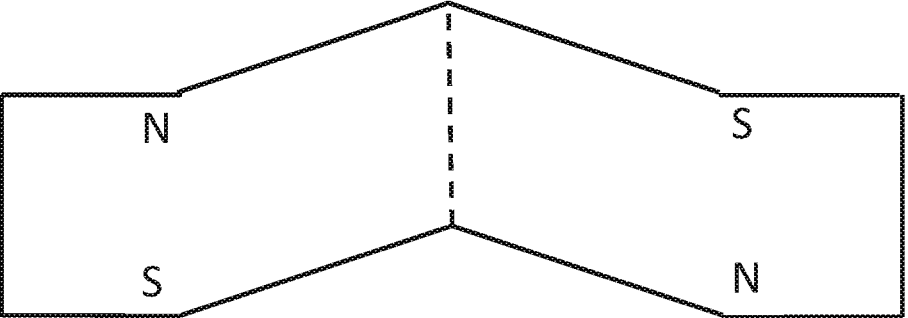

FIG. 11-vi

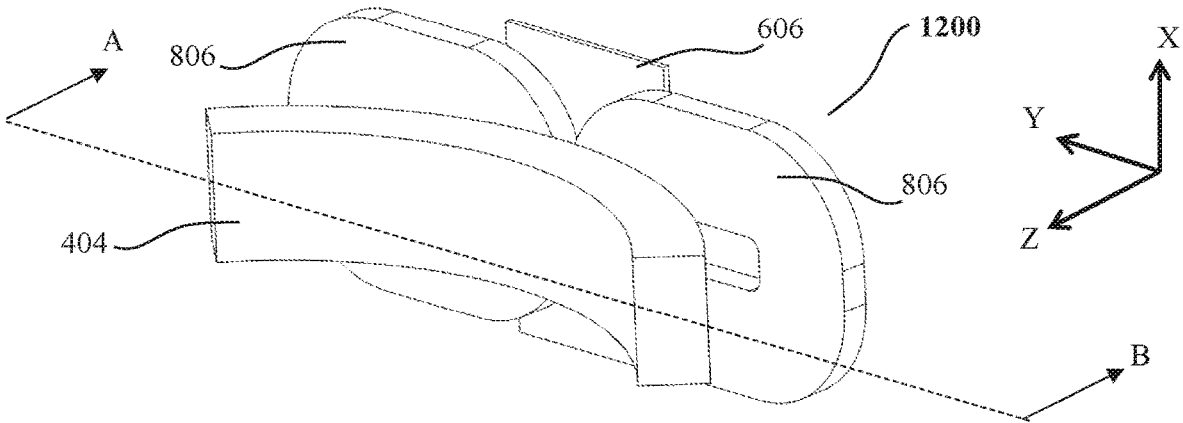

FIG. 12A

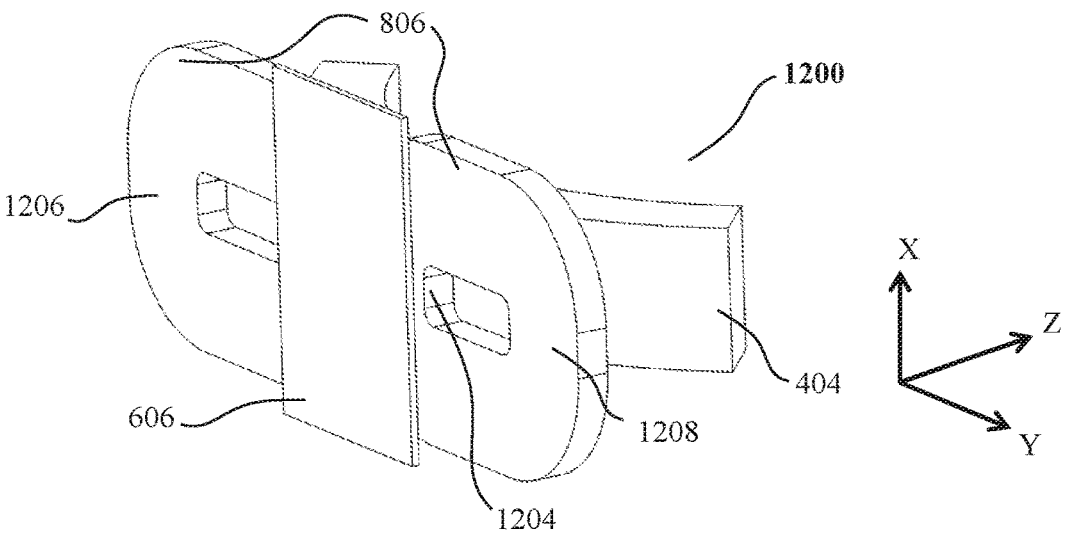

FIG. 12B

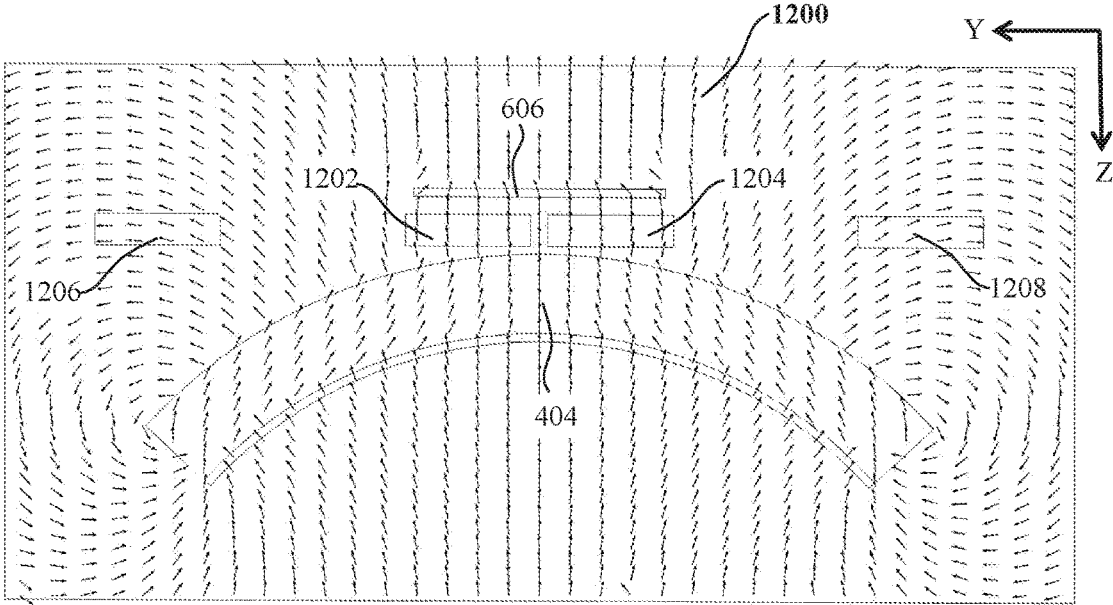

FIG. 12C

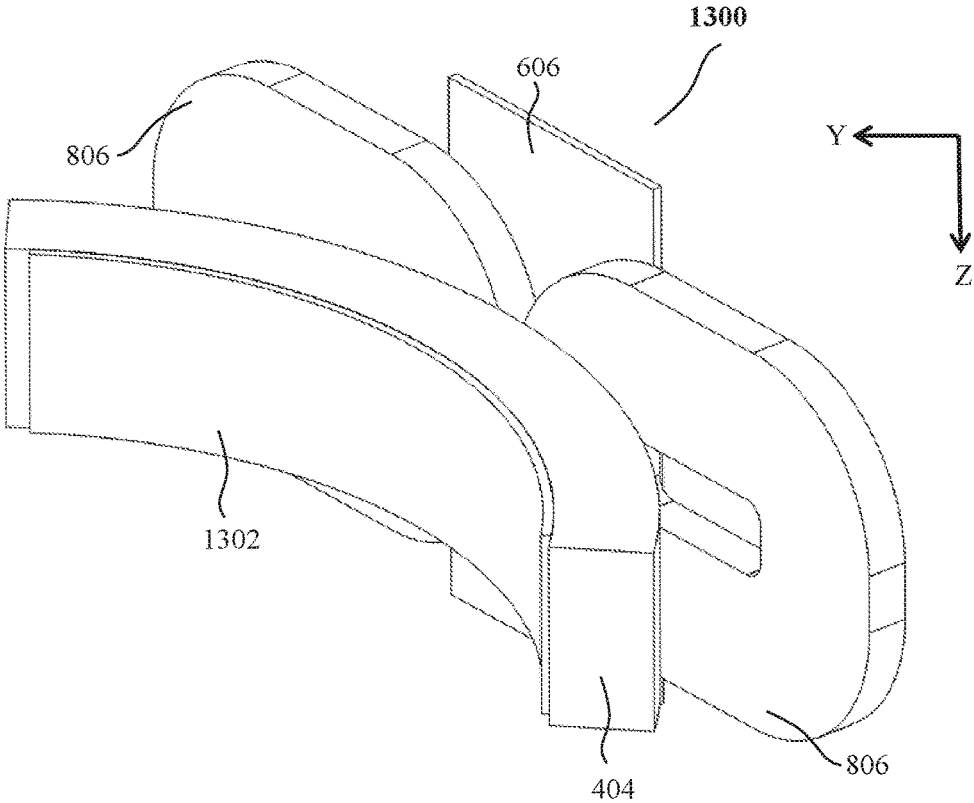

FIG. 13

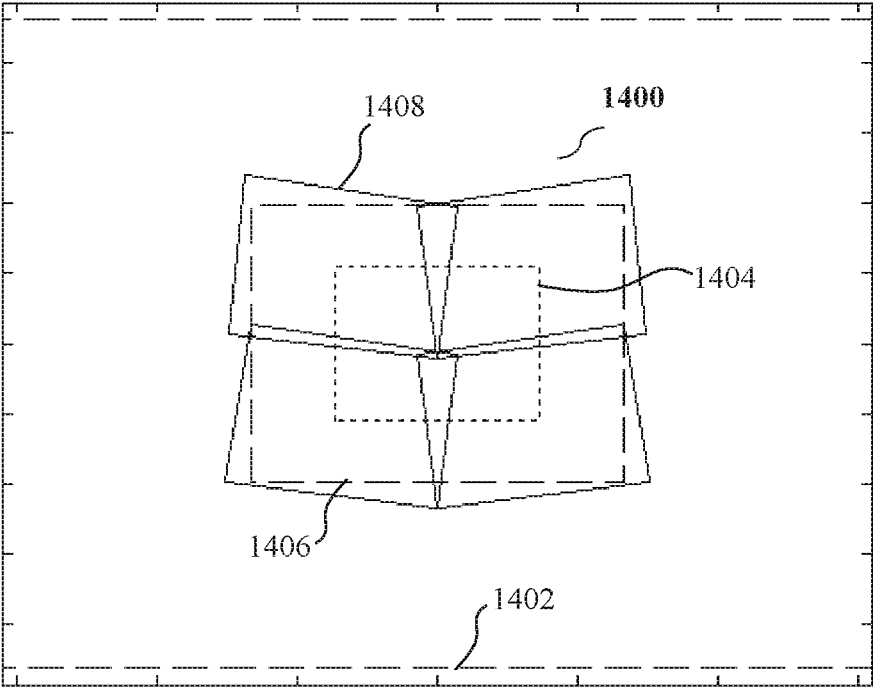

FIG. 14A

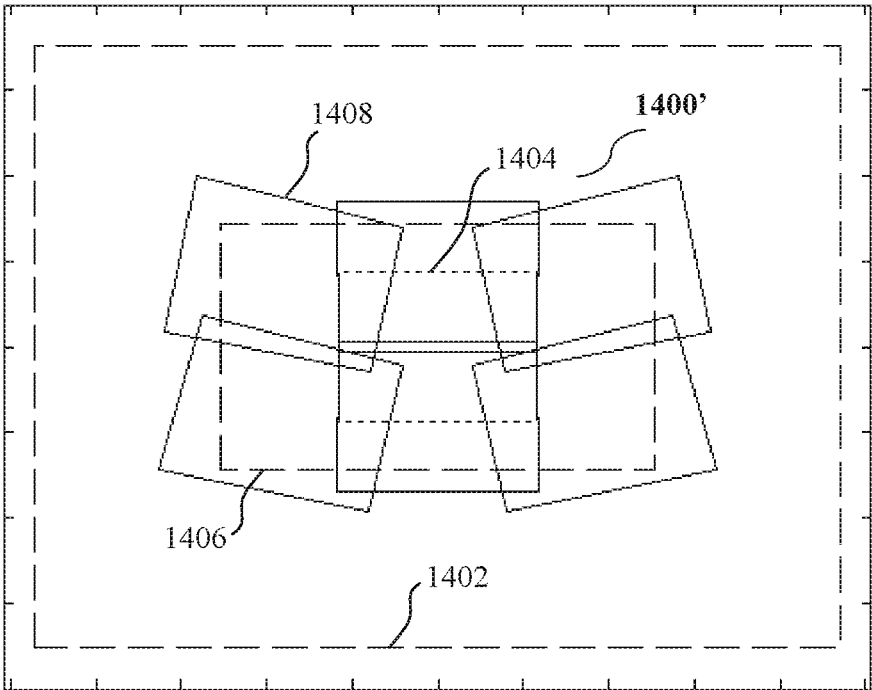

FIG. 14B

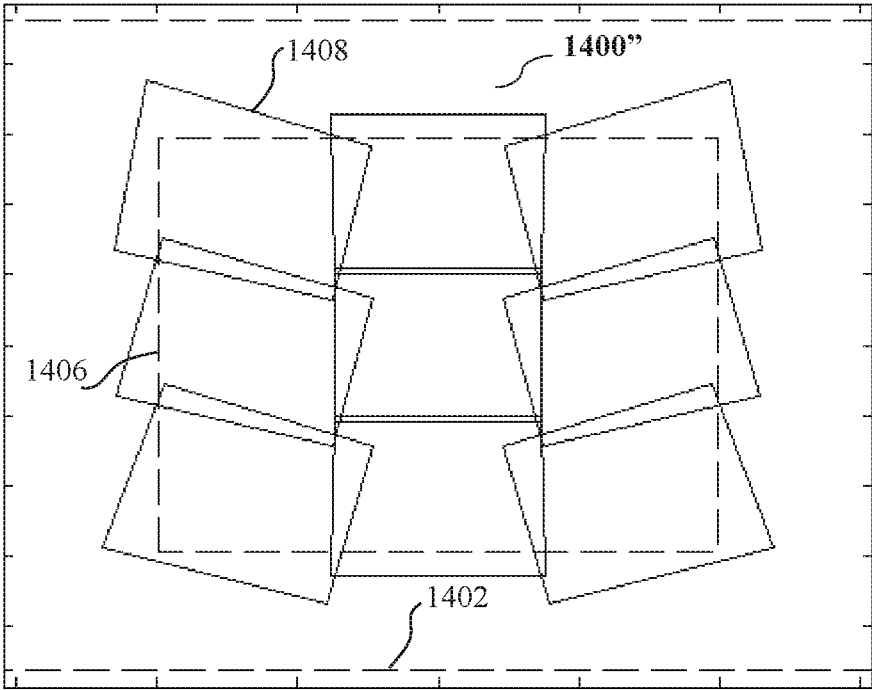

FIG. 14C

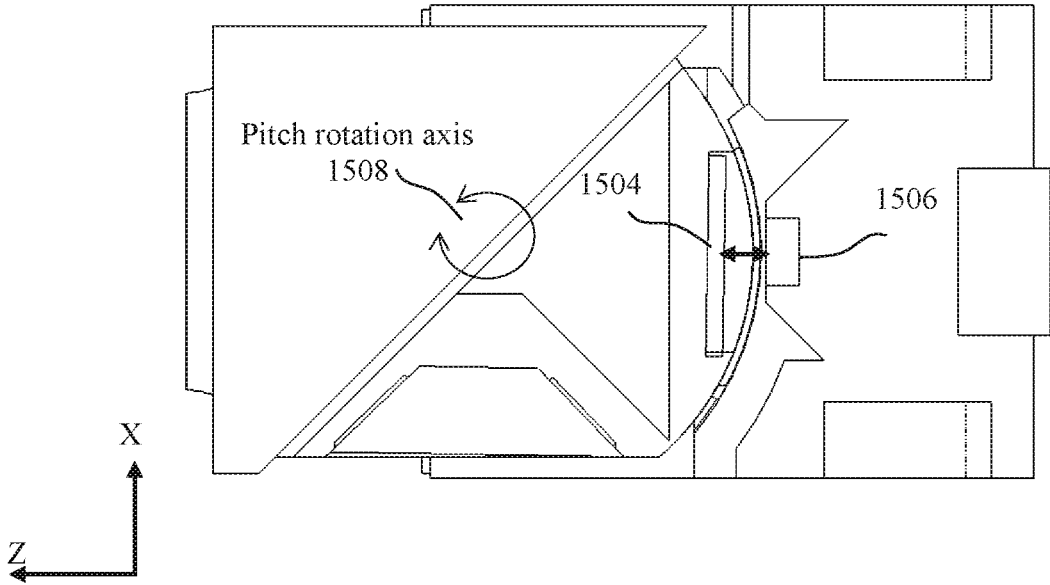

FIG. 15A

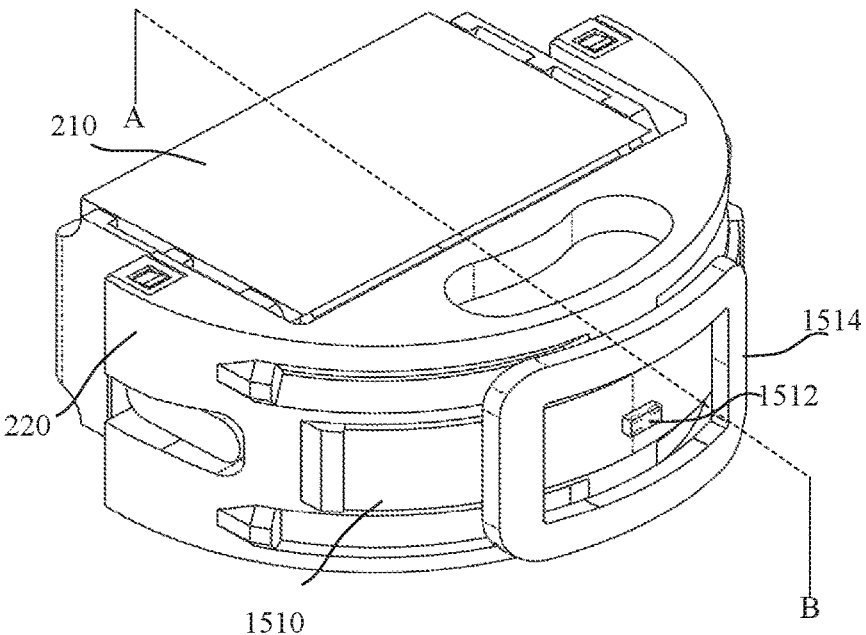

FIG. 15B

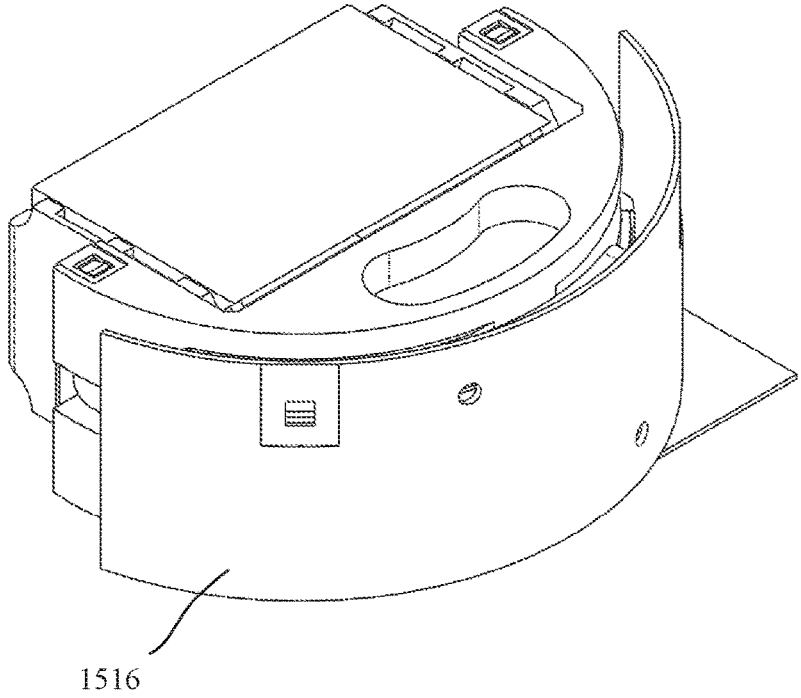

FIG. 15C

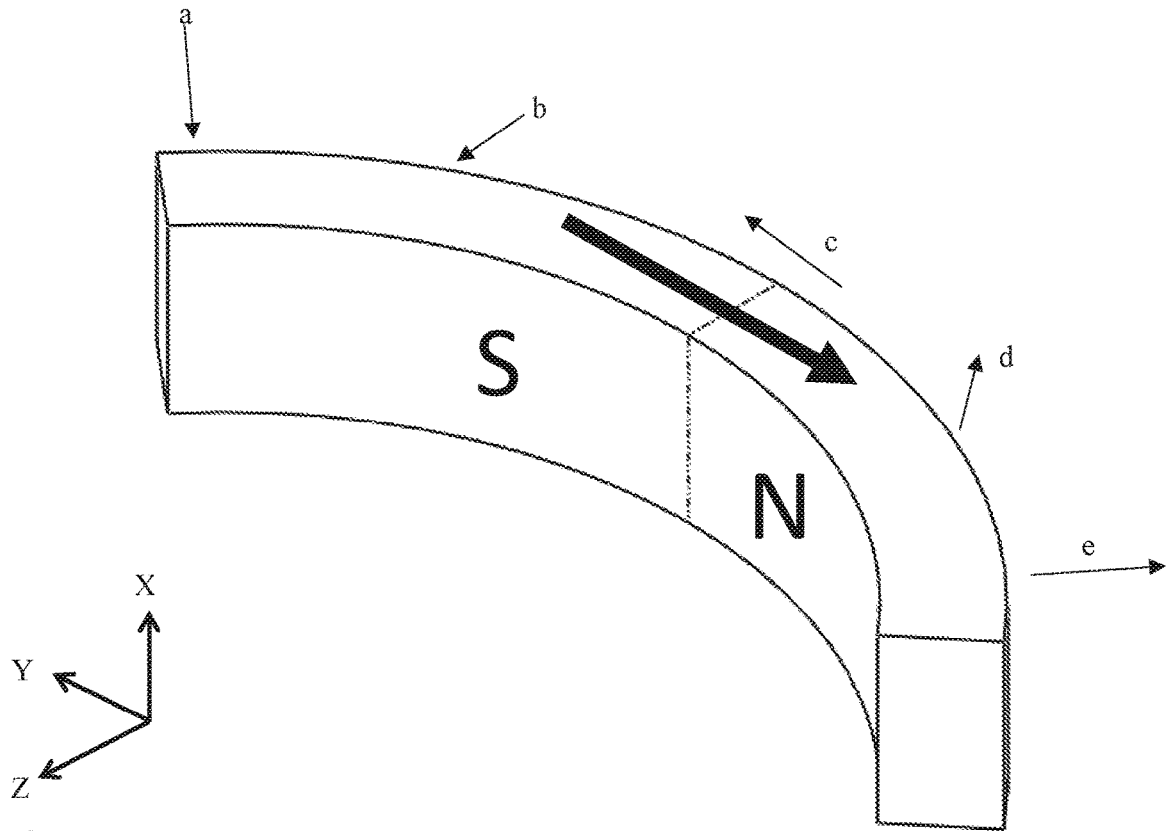

FIG. 15D

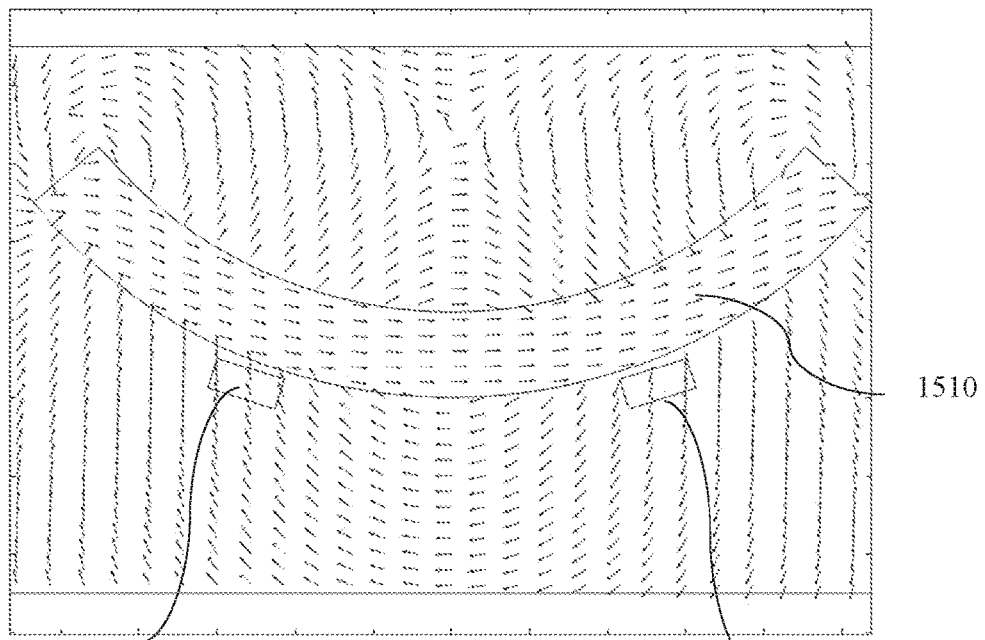

FIG. 15E

One sensor position

Another sensor position

**OPTICAL-PATH FOLDING-ELEMENT WITH
AN EXTENDED TWO DEGREE OF
FREEDOM ROTATION RANGE**

CROSS-REFERENCE TO RELATED
APPLICATIONS

[0001] This is a continuation application from U.S. patent application Ser. No. 18/337,005 filed Jun. 18, 2023 (now allowed), which was a continuation application from U.S. patent application Ser. No. 18/299,727 filed Apr. 13, 2023 (now U.S. Pat. 11,733,064), which was a continuation application from U.S. patent application Ser. No. 17/984,355 filed Nov. 10, 2022 (now U.S. Pat. 11,650,080), which was a continuation application from U.S. patent application Ser. No. 17/829,722 filed Jun. 1, 2022 (now U.S. Pat. No. 11,506,513), which was a continuation application from U.S. patent application Ser. No. 17/013,561 filed Sep. 5, 2020 (now U.S. Pat. No. 11,359,937), which was a continuation application from U.S. patent application Ser. No. 16/615,310 filed Nov. 20, 2019 (now U.S. Pat. No. 11,268,829), which was a 371 application from international patent application PCT/IB2019/053315 filed Apr. 22, 2019, and is related to and hereby claims the priority benefit of commonly-owned and co-pending U.S. Provisional Patent Application No. 62/661,158 filed Apr. 23, 2018, which is incorporated herein by reference in its entirety.

FIELD

[0002] The subject matter disclosed herein relates in general to a folded-lens and to digital cameras with one or more folded lens.

BACKGROUND

[0003] In recent years, mobile devices such as cell-phones (and in particular smart-phones), tablets and laptops have become ubiquitous. Many of these devices include one or two compact cameras including, for example, a main rear-facing camera (i.e. a camera on the back face of the device, facing away from the user and often used for casual photography), and a secondary front-facing camera (i.e. a camera located on the front face of the device and often used for video conferencing).

[0004] Although relatively compact in nature, the design of most of these cameras is similar to the traditional structure of a digital still camera, i.e. it comprises a lens module (or a train of several optical elements) placed on top of an image sensor. The lens module refracts the incoming light rays and bends them to create an image of a scene on the sensor. The dimensions of these cameras are largely determined by the size of the sensor and by the height of the optics. These are usually tied together through the focal length (“f”) of the lens and its field of view (FOV)—a lens that has to image a certain FOV on a sensor of a certain size has a specific focal length. Keeping the FOV constant, the larger the sensor dimensions (e.g. in a X-Y plane), the larger the focal length and the optics height.

[0005] A “folded camera module” structure has been suggested to reduce the height of a compact camera. In the folded camera module structure, an optical path folding element (referred to hereinafter as “OPFE” that includes a reflection surface such as a prism or a mirror; otherwise referred to herein collectively as a “reflecting element”) is added in order to tilt the light propagation direction from a

first optical path (e.g. perpendicular to the smart-phone back surface) to a second optical path, (e.g. parallel to the smart-phone back surface). If the folded camera module is part of a dual-aperture camera, this provides a folded optical path through one lens module (e.g. a Tele lens). Such a camera is referred to herein as a “folded-lens dual-aperture camera” or a “dual-aperture camera with a folded lens”. In some examples, the folded camera module may be included in a multi-aperture camera, e.g. together with two “non-folded” camera modules in a triple-aperture camera.

[0006] A folded-lens dual-aperture camera (or “dual-camera”) with an auto-focus (AF) mechanism is disclosed in Applicant’s US published patent application No. **20160044247**.

SUMMARY

[0007] According to one aspect of the presently disclosed subject matter there is provided an actuator for rotating an OPFE in two degrees of freedom in an extended rotation range a first sub-assembly, a second sub-assembly and a stationary sub-assembly, the first sub-assembly configured to rotate the OPFE relative to the stationary sub-assembly in an extended rotation range around a yaw rotation axis and the second sub-assembly configured to rotate the OPFE relative to the first sub-assembly in an extended rotation range around a pitch rotation axis that is substantially perpendicular to the yaw rotation axis; a first sensor configured to sense rotation around the yaw rotation axis and a second sensor configured to sense rotation around the pitch rotation axis, the first and second sensors being fixed to the stationary sub-assembly, wherein at least one of the first sensor or the second sensor is a magnetic flux sensor; and a voice coil motor (VCM) comprising a magnet and a coil, wherein the magnet is fixedly attached to one of the first sub-assembly or the second sub-assembly, wherein the coil is fixedly attached to the stationary sub-assembly, wherein a driving current in the coil creates a force that is translated to a torque around a respective rotation axis, and wherein the second sensor is positioned such that sensing by the second sensor is decoupled from the rotation of the OPFE around the yaw rotation axis.

[0008] In addition to the above features, the actuator according to this aspect of the presently disclosed subject matter can optionally comprise one or more of features (i) to (xxv) listed below, in any technically possible combination or permutation:

[0009] i. wherein the actuator is adapted to be installed and operable in a folded digital camera for rotating the OPFE within the camera,

[0010] ii. wherein the actuator comprises a first actuation mechanism (including a first VCM) configured to rotate the first sub-assembly around the yaw rotation axis and a second actuation mechanism (including a second VCM) configured to rotate the second sub-assembly around the yaw rotation axis,

[0011] iii. wherein the actuator comprises a first sensing mechanism that comprises the first sensor and a respective first magnet configured to sense the rotation around the yaw rotation axis and a second sensing mechanism that comprises the second sensor and a second magnet configured to sense the rotation around the pitch rotation axis,

- [0012] iv. wherein the yaw rotation axis passes through the second sensor to thereby decouple the second sensor from rotation around the yaw axis,
- [0013] v. wherein the yaw rotation axis passes through a center of the second sensor,
- [0014] vi. wherein the actuator further comprises a first curved ball-guided mechanism operative to enable the rotation around the pitch axis, and a second curved ball-guided mechanism operative to enable the rotation around the yaw axis,
- [0015] vii. wherein the actuator further comprises a curved ball-guided mechanism operative to enable the rotation around the yaw axis, the curved ball-guided mechanism is located on a side of the OPFE which is opposite to side facing an image sensor,
- [0016] viii. wherein the extended rotation range is equal to or greater than ± 5 degrees around the pitch and yaw rotation axes,
- [0017] ix. wherein the extended rotation range is equal to or greater than ± 10 degrees the pitch and yaw rotation axes,
- [0018] x. wherein the extended rotation range is between ± 15 -40 degrees around the pitch and yaw rotation axes,
- [0019] xi. wherein the extended rotation range around the pitch rotation axis is different from the extended rotation range around the second rotation axis,
- [0020] xii. wherein the at least one voice coil motor includes a pitch magnet and a coil dedicated for generating the rotation around the pitch rotation axis and wherein the pitch magnet is designed with a flat surface facing the coil,
- [0021] xiii. wherein the magnetic sensor is a magnetic flux sensor such as a Hall sensor.
- [0022] xiv. wherein the actuator comprises a sensing mechanism that includes the first sensor and a magnet (e.g. yaw sensing magnet), the magnet is shaped or formed such that a central part of the sensing magnet is further away from a projection line of motion of the first sensor, relative to an end of the sensing magnet,
- [0023] xv. wherein the actuator comprises a sensing magnet (e.g. yaw sensing magnet) shaped such that width of a cross section of the sensing magnet increases from a point substantially at its center towards each end of the magnet, thereby resulting in a variable distance between the first sensor and the magnet when relative movement occurs between the sensing magnet and the sensor,
- [0024] xvi. wherein the actuator further comprises a first magnet-yoke pair which pulls the first sub-assembly to the second sub-assembly in a radial direction relative to the pitch rotation axis and a second magnet-yoke pair which pulls the first sub-assembly to the stationary sub-assembly in a radial direction relative to the yaw rotation axis,
- [0025] xvii. wherein the first sub-assembly comprises a middle moving frame, the second sub-assembly comprises an OPFE holder, and the stationary sub-assembly comprises a base; wherein the first magnet-yoke pair pulls the OPFE holder to middle moving frame and the second magnet-yoke pair pulls the middle moving frame to the base,
- [0026] xviii. wherein the first sub-assembly comprises a middle moving frame and the second sub-assembly comprises an OPFE holder, and the stationary sub-assembly comprises a base; wherein rotation around the yaw rotation axis is generated by rotating the middle moving frame relative to the base and rotation around the pitch rotation axis is generated by rotating the OPFE holder relative to the middle moving frame,
- [0027] xix. wherein the actuator comprises a magnet characterized by a cut sphere shape and a coil characterized by a circular shape, the coil is symmetrically positioned around the cut sphere,
- [0028] xx. wherein the actuator comprises a single magnet that is used for creating an actuation force for rotation around the yaw rotation axis, creating a preload force in a magnet-yoke pair for holding together the first sub-assembly and the stationary sub-assembly, and sensing the rotation around the yaw rotation axis.
- [0029] xxi. wherein the actuator comprises only one magnetic flux sensor that is used for sensing rotation around the yaw rotation axis,
- [0030] xxii. wherein the single magnet is a polarization magnet characterized by continuous changes in direction of a magnetic field of the magnet along the magnet's length. wherein the first and second sensing mechanisms are decoupled from each other,
- [0031] xxiii. wherein the actuator is designed to be installed in a folded camera that comprises a lens module accommodating a plurality of lens elements along an optical axis; wherein the OPFE redirects light that enters the folded camera from a direction of a view section along a first optical path to a second optical path that passed along the optical axis,
- [0032] xxiv. wherein the actuator comprises a pitch magnet located at a side of the OPFE that is opposite to the side facing the view section,
- [0033] xxv. wherein the actuator comprises a yaw magnet located at a side of the OPFE that is opposite to the side facing the lens module,
- [0034] According to another aspect of the presently disclosed subject matter there is provided a folded camera comprising the actuator according to the previous aspect.
- [0035] In addition to the above features, the folded camera according to this aspect of the presently disclosed subject matter can optionally comprise one or more of features (i) to (xxv) listed above, in any technically possible combination or permutation.
- [0036] According to yet another aspect of the presently disclosed subject matter there is provided an actuator for rotating an OPFE with a first degree of freedom (DOF) around a first rotation axis and a second DOF around a second rotation axis, comprising:
- [0037] a) a first actuation mechanism for rotation in the first DOF;
- [0038] b) a first sensing mechanism for sensing movement in the first DOF;
- [0039] c) a second actuation mechanism for rotation in the second DOF; and
- [0040] d) a second sensing mechanism for sensing movement in the second DOF;
- [0041] wherein first and second actuation mechanisms are configured to rotate the OPFE around the respective first or second rotation axis in an extended rotation range,
- [0042] and wherein in some examples the first and second actuation mechanism are voice coil motors and

the second sensing mechanism comprises a sensor positioned such that rotation of the OPFE around the first rotation axis is decoupled from the second sensor.

[0043] In addition to the above features, the camera according to this aspect of the presently disclosed subject matter can optionally comprise one or more of features (i) to (xxv) listed above, in any technically possible combination or permutation.

[0044] According to another aspect of the presently disclosed subject matter there is provided a sensing mechanism for sensing rotation movement around a rotation axis, comprising a magnet and a magnetic sensor configured to detect a magnetic flux of the magnet and to determine a relative shift between the magnet and the magnetic sensor based on change in the detected magnetic flux, wherein the magnet is shaped such that a cross section of the magnet has a width that increases from a point substantially at a center of the magnet towards each end of the magnet, thereby increasing a range of detectable change in the magnetic flux and increasing a corresponding detectable range of the relative shift between the magnet and the magnetic sensor.

[0045] In addition to the above features, the actuator according to this aspect of the presently disclosed subject matter can optionally comprise one or more of features (i) to (iv) listed below, in any technically possible combination or permutation:

[0046] i. wherein the detectible range of relative shift between the magnet and the magnetic sensor is of more than 0.8 mm,

[0047] ii. wherein the detectible range of relative shift between the magnet and the magnetic sensor is of more than 1.0 mm,

[0048] iii. wherein the detectible range of relative shift between the magnet and the magnetic sensor is of more than 2.0 mm, and

[0049] iv. wherein the magnetic sensor is a Hall bar sensor.

BRIEF DESCRIPTION OF THE DRAWINGS

[0050] Non-limiting examples of the presently disclosed subject matter are described below with reference to figures attached hereto that are listed following this paragraph. Identical structures, elements or parts that appear in more than one figure may be labeled with the same numeral in the figures in which they appear. The drawings and descriptions are meant to illuminate and clarify embodiments disclosed herein, and should not be considered limiting in any way.

[0051] FIG. 1A illustrates a folded camera with an optical path folding element (OPFE) with an extended 2 degrees-of-freedom (DOF) rotation range, according to some examples of the presently disclosed subject matter;

[0052] FIG. 1B shows the folded camera of FIG. 1A with an OPFE actuator, according to some examples of the presently disclosed subject matter;

[0053] FIG. 1C shows a dual-camera that includes a folded camera as in FIG. 1A together with an upright (non-folded) camera, according to some examples of the presently disclosed subject matter;

[0054] FIG. 2A shows an OPFE actuator of the folded camera of FIG. 1 in an isometric view, according to some examples of the presently disclosed subject matter;

[0055] FIG. 2B shows the actuator in FIG. 2A without a shield, according to some examples of the presently disclosed subject matter;

[0056] FIG. 3A shows a top actuated sub-assembly of the actuator of FIGS. 2A and 2B from one side, according to some examples of the presently disclosed subject matter;

[0057] FIG. 3B shows the top actuated sub-assembly of FIG. 3A from an opposite side, according to some examples of the presently disclosed subject matter;

[0058] FIG. 3C shows the top actuated sub-assembly of FIG. 3A in an exploded view, according to some examples of the presently disclosed subject matter;

[0059] FIG. 4A shows a bottom actuated sub-assembly of the actuator of FIGS. 2A and 2B from one side, according to some examples of the presently disclosed subject matter;

[0060] FIG. 4B shows the bottom actuated sub-assembly of FIG. 4A from an opposite side, according to some examples of the presently disclosed subject matter;

[0061] FIG. 4C shows the bottom actuated sub-assembly in an exploded view, according to some examples of the presently disclosed subject matter;

[0062] FIG. 5A shows the top and bottom actuated sub-assemblies installed together in an isometric view, according to some examples of the presently disclosed subject matter;

[0063] FIG. 5B shows the top and bottom actuated sub-assemblies installed together in a cut along a line A-B shown in FIG. 5A, according to some examples of the presently disclosed subject matter;

[0064] FIG. 6A shows a stationary sub-assembly of the actuator of FIGS. 2A and 2B from one side, according to some examples of the presently disclosed subject matter;

[0065] FIG. 6B shows the stationary sub-assembly of FIG. 6A from an opposite side, according to some examples of the presently disclosed subject matter;

[0066] FIG. 6C shows the stationary actuated sub-assembly in an exploded view, according to some examples of the presently disclosed subject matter;

[0067] FIG. 7 shows the actuator of FIG. 2B along a cut along line A-B shown in FIG. 2A, according to some examples of the presently disclosed subject matter;

[0068] FIG. 8 shows details of an electronic circuitry included in the stationary sub-assembly of FIGS. 6A-6C, according to some examples of the presently disclosed subject matter;

[0069] FIG. 9A shows a pitch actuation and sensing mechanism of the actuator in FIGS. 2A-2B in an isometric view, according to some examples of the presently disclosed subject matter;

[0070] FIG. 9B shows a side cut along a line A-B shown in FIG. 9A of the pitch actuation and sensing mechanism of FIG. 9A, according to some examples of the presently disclosed subject matter;

[0071] FIG. 10A shows a pitch actuation and sensing mechanism of the actuator in FIGS. 2A-2B in an isometric view, according to other examples of the presently disclosed subject matter;

[0072] FIG. 10B shows a side cut of the pitch actuation and sensing mechanism of FIG. 10A along a line A-B shown in FIG. 10A, according to some examples of the presently disclosed subject matter;

[0073] FIG. 11A shows a yaw sensing mechanism of the actuator in FIGS. 2A-2B, according to some examples of the presently disclosed subject matter;

[0074] FIG. 11B shows a yaw rotation range β , a distance R_{YAW} between a yaw Hall bar element and a yaw rotation axis, and a trajectory of a yaw sensing magnet of the yaw

sensing mechanism of FIG. 11A in the Y-Z plane, according to some examples of the presently disclosed subject matter;

[0075] FIG. 11C shows one magnetic configuration for the yaw sensing magnet of FIG. 11B in a cut along a line A-B shown in FIG. 11A, according to some examples of the presently disclosed subject matter;

[0076] FIG. 11D shows another magnetic configuration for the yaw sensing magnet of FIG. 11B in a cut along a line A-B shown in FIG. 11A, according to some examples of the presently disclosed subject matter;

[0077] FIG. 11E shows yet another magnetic configuration for the yaw sensing magnet of FIG. 11B in a cut along a line A-B shown in FIG. 11A, according to some examples of the presently disclosed subject matter;

[0078] FIG. 11F shows the magnetic field as a function of rotation along a given trajectory for the cases presented in FIGS. 11C-E, according to some examples of the presently disclosed subject matter;

[0079] FIG. 11-i to FIG. 11-vi show various possible alternative examples of magnetic configuration for the yaw sensing magnet.

[0080] FIG. 12A shows a yaw magnetic actuation mechanism in an isometric view from one side, according to some examples of the presently disclosed subject matter

[0081] FIG. 12B shows the yaw magnetic actuation mechanism of FIG. 12A in an isometric view from another side, according to some examples of the presently disclosed subject matter;

[0082] FIG. 12C shows magnetic field directions in a Y-Z plane along a cut A-B in FIG. 12A, according to some examples of the presently disclosed subject matter;

[0083] FIG. 13 shows additional magnetic yoke positioned next to yaw magnet, according to some examples of the presently disclosed subject matter;

[0084] FIG. 14A is a schematic illustration of a stitched image generated from four Tele images, according to some examples of the presently disclosed subject matter;

[0085] FIG. 14B is a schematic illustration of a stitched image generated from six Tele images, according to some examples of the presently disclosed subject matter;

[0086] FIG. 14C is a schematic illustration of a stitched image generated from nine Tele images, according to some examples of the presently disclosed subject matter;

[0087] FIG. 15A is a cross section of top actuated sub-assembly and bottom actuated sub-assembly installed together along a cut along line A-B shown in FIG. 15B, according to other examples of the presently disclosed subject matter;

[0088] FIG. 15B is an isometric view of top actuated sub-assembly and bottom actuated sub-assembly installed together of the example shown in FIG. 15A, according to other examples of the presently disclosed subject matter;

[0089] FIG. 15C is an isometric view of top actuated sub-assembly and bottom actuated sub-assembly installed together, showing an external yoke, according to other examples of the presently disclosed subject matter;

[0090] FIG. 15D is a schematic illustration of a single polarization magnet, according to some examples of the presently disclosed subject matter; and

[0091] FIG. 15E is a schematic illustration of the magnetic field lines directions in a Y-Z plane of the single polarization magnet illustrated in FIG. 15D, according to some examples of the presently disclosed subject matter.

DETAILED DESCRIPTION

[0092] For the sake of clarity, the term “substantially” is used herein to imply the possibility of variations in values within an acceptable range as would be known to a person skilled in the art. According to one example, the term “substantially” used herein should be interpreted to imply possible variation of up to 10% over or under any specified value. According to another example, the term “substantially” used herein should be interpreted to imply possible variation of up to 5% over or under any specified value. According to a further example, the term “substantially” used herein should be interpreted to imply possible variation of up to 2.5% over or under any specified value. For example, the phrase substantially perpendicular should be interpreted to include possible variations from exactly 90°.

[0093] FIG. 1A illustrates a folded camera 100 with a 2 degrees-of-freedom (DOF) optical path folding element (OPFE) with an extended rotation range, according to an example of the presently disclosed subject matter. An orthogonal X-Y-Z coordinate (“axis”) system shown applies also to all following drawings. This coordinate system is exemplary only and should not be construed as limiting. In some examples, the term “extended rotation range” used herein is used to describe a rotation range larger than the 2-3 degrees necessary for another application, for example optical image stabilization (OIS). In an example, an extended rotation range may be a range equal to or greater than ± 5 degrees in each DOF relative to an OPFE zero state (as defined below). According to another example, an extended rotation range may be a range equal to or greater than ± 10 degrees in each DOF relative to an OPFE zero state (as defined below). According to yet another example, an extended rotation range may be a range between ± 15 -40 degrees in each DOF relative to an OPFE zero state (as defined below). The extended rotation range may or may not be equal in the two DOF. In an example, the extended rotation range may be twice or more in the yaw DOF than in the pitch DOF, because the optical effect (shift of image on the image sensor) of pitch rotation is double the optical effect of yaw rotation.

[0094] Camera 100 includes a lens assembly or lens module (or simply “lens”) 102, an OPFE 104 and an image sensor 106. In general lens module 102 comprises a plurality of lens elements positioned along an optical axis, for example between 3 to 7 lens elements. In some examples, lens 102 has a fixed focal length “f”. In other examples, lens 102 has a variable focal length (zoom lens). In some examples, lens 102 may be a lens designed for folded cameras described for example in co-owned U.S. Pat. No. 9,392,188. OPFE 104 has a reflection surface (e.g. it may be a mirror or a prism).

[0095] OPFE 104 folds light from a first optical path 108 to a second optical path 110. First optical path 108 extends from the direction of a view section 114 (facing an object or scene) towards OPFE 104 and is substantially parallel to the X axis (in the exemplary coordinate system). Second optical path 110 extends from OPFE 104 towards image sensor 106 and is substantially parallel to the Z axis (in the exemplary coordinate system).

[0096] View section 114 may include, for example, one or more objects, a scene and/or a panoramic view, etc. According to the illustrated example, axis 110 is aligned with the optical axis of lens 102, and therefore is also referred to herein as “lens optical axis”. Image sensor 106 may be

aligned with a plane substantially perpendicular to axis **110** (a plane that includes the X and Y axes). Image sensor **106** may output an output image. The output image may be processed by an image signal processor (ISP—not shown), the processing including for example, demosaicing, white balance, lens shading correction, bad pixel correction and other processes that may be carried out by an ISP. In some embodiments, the ISP (or some functionalities of the ISP) may be part of image sensor **106**.

[0097] It is noted that while the OPFE and some of the parts described below may be configured to rotate in two DOF, all the figures, the description and the directions therein show the OPFE in a “zero” state (without rotation) unless otherwise mentioned.

[0098] For the sake of clarity of the description and by way of a non-limiting example only, it is defined that at zero state the first optical path **108** extending from the direction of view section **114** towards the OPFE **104** is perpendicular to a zero plane. The term “zero plane” as used herein refers to an imaginary plane on which an actuator **202** described below is positioned and is parallel to the lens optical axis. For example, in a mobile phone, the zero plane is a plane **15** parallel to the screen of the phone.

[0099] Furthermore, in zero state the reflecting surface of the OPFE is positioned such that light along the first optical path **108** is redirected to a second optical path **108** that coincides with lens optical axis **110**. Notably, the above definition is assumed to be true for the center of the field of view (FOV).

[0100] Yaw rotation can be defined as rotation around an axis substantially parallel to the first optical path in zero state. Pitch rotation can be defined as rotation around an axis substantially perpendicular to the yaw rotation axis and the lens optical axis.

[0101] In some examples, camera **100** may further include a focus or autofocus (AF) mechanism (not shown), allowing to move (or “shift” or “actuate”) lens **102** along axis **110**. The AF mechanism may be configured to adjust the focus of the camera on view section **114**. Adjusting the focus on view section **114** may bring into focus one or more objects and/or take out of focus one or more objects that may be part of view section **114**, depending on their distance from OPFE **104**. For simplicity, the description continues with reference only to AF mechanisms, with the understanding that it also covers regular (manual) focus.

[0102] An AF mechanism may comprise an AF actuation mechanism. The AF actuation mechanism may comprise a motor that may impart motion such as a voice coil motor (VCM), a stepper motor, a shape memory alloy (SMA) actuator and/or other types of motors. An AF actuation mechanism that comprises a VCM may be referred to as a “VCM actuator”. Such actuation mechanisms are known in the art and disclosed for example in Applicant’s co-owned international patent applications PCT/IB2015/056004 and PCT/IB2016/055308. In some embodiments, camera **100** may include an optical image stabilization (OIS) actuation mechanism (not shown) in addition to, or instead of, the AF actuation mechanism. In some embodiments, OIS may be achieved by shifting lens **102** and/or image sensor **106** in one or more directions in the X-Y plane, compensating for tilt of camera **100** around the Z and Y directions. A three-degrees of freedom (3-DOF) OIS and focus actuation mechanism (which performs two movements for OIS and one for AF) may be of VCM type and known in the art, for example as

disclosed in international patent application PCT/US2013/076753 and in US patent application 2014/0327965. In other embodiments, OIS may be achieved by shifting the lens in one direction (i.e. the Y direction), perpendicular to both the first and second optical paths, compensating for tilt of camera **100** around the Z direction (lens optical axis). In this case, a second OIS operation, compensating for tilt of camera **100** around the Z direction may be done by tilting the OPFE around the Y axis, as demonstrated below. More information on auto-focus and OIS in a compact folded camera may be found in Applicant’s co-owned international patent applications PCT/IB2016/052143, PCT/IB2016/052179 and PCT/IB2016/053335.

[0103] Camera **100** is designed with a capability to rotate OPFE **104** with at least two DOF (2-DOF) in an extended rotation range. Rotation can be done for example using OPFE actuator **120**, seen in FIG. **1B**. Two-DOF rotation may be used to describe rotation of the prism around two axes (each axis being a DOF); in camera **100**, the degrees of freedom are a yaw rotation **132** around yaw rotation axis **122** which is parallel to first optical path **108** (X axis) when in zero state as defined above, and a pitch rotation **134** around a pitch rotation axis **124** which is parallel to the Y axis. In camera **100**, yaw rotation axis **122** and pitch rotation axis **124** may intersect, which may reduce coupling between a pitch sensing mechanism and yaw rotation, as described below with reference to FIG. **9**. In camera **100**, lens optical axis **110** intersects the intersection point of yaw rotation axis **122** and pitch rotation axis **124**. In other embodiments, this may not be the case.

[0104] As shown in FIG. **1C**, camera **100** may be a part of a dual-camera **180**. Dual-camera **180** comprises camera **100** and an upright camera **190**. Upright camera **190** includes a lens **192** and an image sensor **194**. Upright camera **190** may further include other parts such as a shield, a focus or AF mechanism, and/or an OIS mechanism (all of which are not shown), as known in the art. Cameras **100** and **190** may share some or all of respective fields of view (FOVs). According to some examples, camera **190** may have a wider FOV than camera **100**. In such an example, camera **100** will be referred as a “Tele camera”, while camera **190** will be referred as a “Wide camera”. In such an example, a scanning mechanism of camera **100** may be used to cover some or all of the FOV of camera **190**, as explained in the description below of FIGS. **14A-14C**. In other examples, camera **100** may be a part of a multiple aperture camera (multi-camera) comprising more than two cameras, e.g. comprising two or more additional upright and/or two or more additional folded cameras. Notably, while characterized by extended rotation ranges, camera **100** and actuator **120** may also be capable of performing small range (1-2 degree) actuations with high accuracy, which enable OIS around any position in the extended rotation range.

[0105] FIGS. **2A-B** show OPFE actuator **120** with more details according to some non-limiting examples of the presently disclosed subject matter. FIG. **2A** shows OPFE actuator **120** in an isometric view. OPFE actuator **120** may be covered by a shield **202** with an opening **204** through which light can enter into OPFE **104** and an opening **206** through which light can exit from OPFE **104**. FIG. **2B** shows actuator **120** without shield **202**. Actuator **120** further includes a bottom actuated sub-assembly **220** (also referred to herein as “yaw sub-assembly” or “first sub-assembly”), a top actuated sub-assembly **210** (also referred to herein as

“pitch sub-assembly” or “second sub-assembly”), and a stationary sub-assembly 230. Top actuated sub-assembly 210 may be operable to be rotated, and thus rotate OPFE 104, around the pitch rotation axis (parallel to the Y axis) relative to bottom actuated sub-assembly 220 (pitch rotation 134), as described below. Bottom actuated sub-assembly 220 may be operable to be rotated, and thus rotate OPFE 104, around the yaw rotation axis (parallel to the X axis) relative to stationary sub-assembly 230 (yaw rotation 132), as described below.

[0106] As described in more detail below, according to one example, the bottom (yaw) actuated sub-assembly 220 rotates relative to a stationary sub-assembly and the top (pitch) actuated sub-assembly 210 rotates relative to the bottom sub-assembly, thus the bottom sub-assembly acts as a master and the top sub-assembly acts as a slave. Applicant has found that this design, with the bottom actuated sub-assembly used for yaw rotation and the top actuated sub-assembly used for pitch rotation, and with the bottom actuated sub-assembly serving as a master and the top actuated sub-assembly serving as a slave, enables to maintain a lower overall height of the actuator and thus to mitigate a penalty on the folded camera height.

[0107] FIGS. 3A-C show top (pitch) actuated sub-assembly 210 with more details in an isometric view from one side (FIG. 3A), an isometric view from another side (FIG. 3B), and an exploded view (FIG. 3C), according to some non-limiting examples of the presently disclosed subject matter. Top actuated sub-assembly 210 includes an OPFE holder (or carrier) 302 that can be made, for example, by a plastic mold that fits the shape of OPFE 104. Top actuated sub-assembly 210 further includes a permanent (fixed) pitch magnet 304. Pitch magnet 304, as well as all other magnets in this application, can be for example a permanent magnet, made from a neodymium alloy (e.g. $\text{Nd}_2\text{Fe}_{14}\text{B}$) or a samarium-cobalt alloy (e.g. SmCo_5), and can be made by sintering. According to one example, pitch magnet 304 is fixedly attached (e.g. glued) to OPFE carrier 302 from below (negative X direction in FIG. 3A). Hereinafter, the term “below” used with reference to the position of OPFE 104 refers to a side of the OPFE opposite to the side facing the view section (in the negative X direction relative to the view). Details of pitch magnet 304 and its operation are given below. In some examples, OPFE carrier 302 includes (e.g. is molded with) two pins 308.

[0108] Sub-assembly 210 may further include two ferromagnetic yokes 306. Ferromagnetic yokes 306 may be attached (e.g. glued) to OPFE holder 302 on pins 308. Ferromagnetic yokes 306 may be made of a ferromagnetic material (e.g. iron) and have an arced (curved) shape with a center on pitch rotation axis 124. Ferromagnetic yokes 306 are pulled by pitch-pull magnets 408 (see FIGS. 4A, 4C) to attach top actuated sub-assembly 210 to bottom actuated sub-assembly 220 as described below with reference to FIGS. 5A-5C. OPFE holder 302 may further include (e.g. is molded with) two parallel arc-shaped (curved) grooves 310a and 310b (FIG. 3B) positioned at two opposite sides of OPFE holder 302, each arc-shaped groove having an angle $\alpha > \alpha$, where angle α is a desired pitch stroke, as defined by optical needs. Angle α' is shown in FIG. 5B. Arc-shaped grooves 310a and 310b have a center of curvature on pitch rotation axis 124 (see FIGS. 3A, 5A, 5B). OPFE holder 302 further includes (e.g. is molded with) two stoppers 312 (FIG.

3A) positioned at two opposite sides of OPFE holder 302. Stoppers 312 are used to stop OPFE 104 in a required position.

[0109] FIGS. 4A-C show bottom (yaw) actuated sub-assembly 220 with more details in an isometric view from one side (FIG. 4A), an isometric view from another side (FIG. 4B), and an exploded view (FIG. 4C). Bottom actuated sub-assembly 220 includes a middle moving frame 402 which can be made, for example, by a plastic mold. Bottom actuated sub-assembly 220 further included four permanent (fixed) magnets: a yaw actuation magnet 404, a yaw sensing magnet 406, and two pitch-pull magnets 408. All magnets are fixedly attached (e.g. glued) to middle moving frame 402. Notably, yaw magnet 404 is located on a side of the OPFE that is opposite to the side facing lens module 102 in camera 100. Details of all magnets and their operation are given below.

[0110] Bottom actuated sub-assembly 220 further includes two stoppers 410, made for example from a non-magnetic metal. Stoppers 410 are fixedly attached (e.g. glued) to middle moving frame 402. Stoppers 410 help to prevent top actuated sub-assembly 210 from detaching from bottom actuated sub-assembly 220 in case of a strong external impact or drop, as described in more detail below. Middle moving frame 402 includes (i.e. is molded with) two parallel arc-shaped (curved) grooves 412 (FIG. 4A) positioned at two opposite sides of middle moving frame 402, each arc-shaped groove having an angle $\alpha' > \alpha$. Angle α' is shown in FIG. 5B. Arc-shaped grooves 412 have a center of curvature on yaw rotation axis 122 (FIG. 5B) in common with arc shaped grooves 310. Middle moving frame 402 further includes (e.g. is molded with) two parallel arc-shaped (or “curved”) grooves 414 (FIG. 4B) positioned at a back side of middle moving frame 402 (negative Z axis), each arc-shaped groove having an angle $\beta' > \beta$, where angle β is a required yaw stroke, as defined by optical needs. Angle β' is shown in FIG. 7. Arc-shaped grooves 414 have a center of curvature on yaw rotation axis 122 (FIG. 7).

[0111] FIGS. 5A-B show top actuated sub-assembly 210 and bottom actuated sub-assembly 220 installed together. FIG. 5A shows an isometric view and FIG. 5B shows a cut along line A-B in FIG. 5A. The figures also show various elements described above. FIG. 5B shows actuator 120 with three balls 512a, 514a and 516a positioned in the space between grooves 310a and 412a, and three balls 512b, 514b and 516b positioned in the space between grooves 310b and 412b. FIG. 5B shows only balls 512b, 514b and 516b and grooves 310b and 412b, while balls 512a, 514a and 516a and grooves 310a and 412a are not seen (being in the unseen back side of the drawing), with understanding of them being symmetric along plane Z-Y. The number of balls (here 3) shown in the drawing is for the sake of example only and should not be construed as limiting. In other embodiments, an actuator such as actuator 120 may have more or fewer of three balls (e.g. 2-7 balls) in the space between adjacent grooves. The balls may be made of Alumina, another ceramic material, metal, plastic or other suitable materials. The balls may have for example a diameter in the range of 0.3-1 mm. In actuator 120, grooves 310a, 301b, 412a, 412b and balls 512a, 512b, 514a, 514b, 516a and 516b form a curved ball-guided mechanism 560 operative to impart a rotation or tilt movement to an optical element (e.g. OPFE 104) upon actuation by the VCM actuator (see below). More details on ball-guided mechanisms in actuators may be

found in co-owned international patent applications PCT/IB2017/052383 and PCT/IB2017/054088.

[0112] In some embodiments, balls having different sizes (e.g. two different ball sizes) may be used to provide smoother motion. The balls can be divided into a large diameter (LD) group and a small diameter (SD) group. The balls in each group may have the same diameter. LD balls may have for example a 0.1-0.3 mm larger diameter than SD balls. A SD ball may be positioned between two LD balls to maintain the rolling ability of the mechanism. For example, balls 512b and 516b may be LD balls and ball 514b may be a SD ball (and similarly for balls 512a-516a). As described above, two metallic ferromagnetic yokes 306 that may be fixedly attached to OPFE holder 302 face two pitch-pull magnets 408 that may be attached to middle frame 402. Ferromagnetic yokes 306 may pull magnets 408 (and thus pull top actuated sub-assembly 210 to bottom actuated sub-assembly 220) by magnetic force and hold a curved ball-guided mechanism 560 from coming apart. The magnetic force (e.g. acting between yoke 306 and magnets 408) that is used for preventing two parts of a moving mechanism to be detached is referred to herein as “pre-load force”. A pitch-pull magnet 408 and its respective yoke 306 may be referred to as “first magnet-yoke pair”. Ferromagnetic yokes 306 and pitch-pull magnets 408 both have arc shapes, with a center on pitch rotation axis 124. The magnetic direction of pitch-pull magnets 408 is along pitch rotation axis 124, e.g. with a north pole toward OPFE 104 and a south pole away from OPFE 104. Due to the geometric and magnetic design presented, the magnetic force (pre-load force) between ferromagnetic yokes 306 and pitch-pull magnets 408 is kept substantially in a radial direction 520 with a center on pitch rotation axis 124, and negligible tangent force, at all rotation positions, as can be seen in FIG. 5A.

[0113] Balls 512a-516a and 512b-516b prevent top actuated sub-assembly 210 from touching bottom actuated sub-assembly 220. Top actuated sub-assembly 210 is thus confined with a constant distance from bottom actuated sub-assembly 220. Curved ball-guided mechanism 560 further confines top actuated sub-assembly 210 along pitch rotation axis 124. Top actuated sub-assembly 210 can only move along the path defined by curved ball-guided mechanism 560, namely in a pitch rotation 134 around pitch rotation axis 124.

[0114] FIGS. 6A-C show stationary sub-assembly 230 with more details, in an isometric view from one side (FIG. 6A), an isometric view from another side (FIG. 6B) and an exploded view (FIG. 6C). Stationary sub-assembly 230 includes a base 602 that can be made, for example, by plastic mold. Stationary sub-assembly 230 further includes electronic circuitry 608 attached to base 602, shown in FIG. 6C. Details of electronic circuitry 608 are given below with reference to FIG. 8. Stationary sub-assembly 230 further includes a ferromagnetic yoke 606. Ferromagnetic yoke 606 is made by ferromagnetic material (e.g. iron) and is pulled by yaw actuation magnet 404 (see FIGS. 6B and 7C) to attach bottom actuated sub-assembly 220 to stationary sub-assembly 230 as described in more detail below. Ferromagnetic yoke 606 and yaw actuation magnet 404 may be referred to as “second magnet-yoke pair”.

[0115] Stationary actuated sub-assembly 230 further include a stopper 610. Stopper 610 is made for example from a non-magnetic metal. Stopper 610 is attached (e.g. glued) to base 602. Stopper 610 helps to prevent bottom

actuated sub-assembly 220 from detaching from base 602 in case of a strong external impact or drop, as described in more detail below. In some examples, base 602 includes (i.e. is molded with) two parallel arc-shaped (curved) grooves 612a-d (FIG. 6A), each arc-shaped groove having an angle $\beta'' > \beta$, where angle β is a required tilt stroke, as defined by optical needs. Angle β'' is shown in FIG. 7. Arc-shaped grooves 612a-d may further include a center of curvature on yaw rotation axis 122 (FIG. 2C, 6A and 7), in common with arc-shaped grooves 414a-b.

[0116] FIG. 7 shows actuator 120 without the shield along a cut along line A-B seen in FIG. 2A. Grooves 612a-d are shown to share a center with grooves 414a-b on yaw rotation axis 122 (612c and 612d, which are shown in FIGS. 6B and 6C are hidden in FIG. 7). Angles β' and β'' are demonstrated. Grooves 612a-b are adjacent to groove 414a while grooves 612c-d are adjacent to groove 414b. Four balls 712 (two are shown in FIG. 7) are positioned between adjacent groove pairs 612a and 414a, 612b and 414a, 612c and 414b, and 612d and 414b, one ball between each adjacent groove pair. In other embodiments, actuator 120 may have more than one ball pair in each adjacent groove pair, e.g. in the range of 1-4 balls. The considerations for size and materials of all balls are similar to those described above. Grooves 414a-b, 612a-d and balls 712 form a second curved ball-guided mechanism 760 of actuator 120. As shown in FIG. 6 and FIG. 7, the second curved ball-guided mechanism is situated such that the grooves 612 for rotating around the yaw axis are located behind OPFE 104 i.e. in the positive direction along the Z axis relative to OPFE 104 (a side opposite to the side facing the lens module).

[0117] As described above, ferromagnetic yoke 606 is fixedly attached to base 602 facing magnet 404 (illustrated for example in FIG. 4a and FIG. 4c). Ferromagnetic yoke 606 pulls magnet 404 (and thus pulls bottom actuated sub-assembly 220) to stationary sub-assembly 230 by magnetic force 702 (pre-load force) and thus holds curved ball-guided mechanisms 760 from coming apart. The direction of magnetic force 702 is marked in FIG. 7 as the Z direction. Balls 712 prevent bottom actuated sub-assembly 220 from touching stationary sub-assembly 230. Bottom actuated sub-assembly 220 is thus confined with a constant distance from stationary sub-assembly 230. Second curved ball-guided mechanism 760 further confines bottom actuated sub-assembly 220 along the Y-axis. Bottom actuated sub-assembly 220 can only move along the path defined by the curved ball-guided mechanism 760, namely in a yaw rotation around yaw rotation axis 122.

[0118] The curved ball-guided mechanisms 560 and 760 disclosed herein provides flexibility when defining the pitch and yaw rotation axes respectively, as the curve can be adapted to the required rotation axis. Furthermore, curved ball-guided mechanisms 560 and 760 enable to execute movement of the top actuated sub-assembly and the bottom actuated sub-assembly by rolling over the balls confined within the grooves (rails) along the path prescribed by the grooves, and thus help to reduce or eliminate friction that may otherwise exist during movement between the balls and the moving parts.

[0119] FIG. 8 shows electronic circuitry 608 with more details, according to some examples of the presently disclosed subject matter. Electronic circuitry 608 includes a printed circuit board (PCB) 802 and may include processing circuitry. PCB 802 allows sending input and output currents

to coils **806** and **804** and to Hall bar elements **808** and **810** (described below), the currents carrying both power and electronic signals needed for operation. PCB **802** may be connected electronically to host camera (camera **100** or similar cameras) or host device (e.g. phone, computer, not shown) e.g. by wires (not shown). PCB **802** may be a flexible PCB (FPCB) or a rigid flex PCB (RFPCB) and may have several layers (e.g. 2-6) as known in the art. Electronic circuitry **608** further includes three coils, a pitch coil **804** and two yaw coils **806**. Electronic circuitry **608** further includes two Hall bar sensing elements, a pitch Hall bar element **808** and a yaw Hall bar element **810**. Coils **804** and **806** and Hall bar elements **808** and **810** are all connected (e.g. soldered) to PCB **802**. In actuator **120**, pitch coil **804** and pitch Hall bar element **808** are positioned below pitch magnet **304**. Notably, some of the components mentioned as part of the electronic circuitry are also considered as part of an actuation and sensing mechanism.

[0120] Notably, yaw rotation axis **122** is positioned as closely as possible to the pitch sensor (e.g. Hall bar element **808**). According to one example, yaw rotation axis **122** passes through pitch sensor **808**, in order to decouple the sensing of the pitch sensor from the rotation around the yaw axis. When decoupled, the influence on the sensing of the pitch sensor by rotation around the yaw axis is reduced or eliminated. More specifically, according to one example, yaw rotation axis **122** passes through the center of pitch sensor **808**. By positioning the yaw rotation axis so it passes through the center of the pitch sensor, the influence of yaw rotation on the sensing of pitch sensor can be completely eliminated. In addition, in some designs, yaw rotation axis **122** may optionally pass through the center of pitch coil **804**.

[0121] FIGS. 9A-B show an example of a pitch actuation and sensing mechanism (PAASM) **900** that includes pitch magnet **304**, pitch coil **804** and pitch Hall bar element **808**. PAASM **900** may be included in actuator **120**. In some embodiments, PAASM **900** may be used only for actuation (acting as an actuation mechanism for one DOF). FIG. 9A shows PAASM **900** in an isometric view and FIG. 9B shows a side cut of pitch magnet **304** along a line A-B. According to one example, pitch magnet **304** may be symmetric along a plane that includes pitch rotation axis **124** and first optical axis **108**. In an example, pitch magnet **304** may be fabricated (e.g. sintered) such that it has a changing magnetic field direction along its mechanical symmetry plane, e.g. a north magnetic field facing the positive X direction on the left side and a north magnetic field facing the negative X direction on the right side. Pitch magnet **304** may have a length R_{PITCH} of a few millimeters (for example 2-6 mm) in parallel to pitch rotation axis **124** and substantially longer than pitch coil **804**, such that its magnetic field on most lines parallel to pitch rotation axis **124** may be considered constant. Upon driving a current in pitch coil **804**, a Lorentz force is created on pitch magnet **304**; a current in a clockwise direction will create force in the positive Z direction (along the Z axis), while a current in counter clockwise direction will create a force in the negative Z direction. Any force on pitch magnet **304** is translated to torque around pitch rotation axis **124**, and thus top actuated subassembly **210** will rotate relative to bottom actuated sub-assembly **220**.

[0122] Pitch Hall bar element (sensor) **808**, which is positioned inside pitch coil **804**, can sense the intensity and direction of the magnetic field of pitch magnet **304** radially directed away from pitch rotation axis **124**. In other words,

for any pitch orientation of top actuated sub-assembly **210**, pitch Hall bar measures the intensity of the magnetic field directed in the X direction only. Since yaw rotation axis **122** passes through pitch Hall bar element **808**, the effect of the yaw rotation of bottom actuated sub-assembly **220** on the magnetic field in the X direction applied by pitch magnet **304** is reduced (e.g. eliminated) and thus any change on the measurement of pitch Hall bar element **808** is reduced (e.g. eliminated) as well. By positioning the Hall bar element **808** such that the yaw rotation axis **122** passes through its center, the effect of the yaw rotation of bottom actuated sub-assembly **220** on the magnetic field in the X direction applied by pitch magnet **304** is reduced (e.g. minimized) and thus any change on the measurement of pitch Hall bar element **808** is mitigated. Pitch Hall bar element **808** can thus measure the respective pitch rotation of top actuated sub-assembly **210** while being unaffected by the yaw rotation of bottom actuated sub-assembly.

[0123] FIGS. 10A-B show another exemplary embodiment of a PAASM numbered **1000**, similar to PAASM **900**. PAASM **1000** may be included in actuator **120**, to replace PAASM **900**. According to one example, a pitch magnet **1004** replaces pitch magnet **304**. Pitch magnet **1004** is a cut of a sphere with its center positioned substantially on the intersection point of yaw rotation axis **122** and pitch rotation axis **124**. According to one example, a pitch coil **1006** that replaces pitch coil **804** has a circular shape with a center substantially on yaw rotation axis **122** (in some examples the yaw rotation axis passes exactly through the center of the coil). Pitch coil **1006** may be made (fabricated) with similar considerations presented above for pitch coil **804**. Due to the symmetry of the pitch magnet around yaw rotation axis **122**, any yaw rotation will not influence the magnetic field of the pitch coil and thus will not change the force applied by pitch coil **1006** on pitch magnet **1004**. Having a constant force for various yaw positions may facilitate and simplify pitch position control (close loop control or open loop control). As mentioned above, yaw rotation axis passes through sensor **808** to thereby reduce the effect of yaw rotation of bottom actuated sub-assembly **220** on the magnetic field in the X direction applied by pitch magnet **1004**.

[0124] FIG. 11A shows a yaw sensing mechanism numbered **1100**. Yaw sensing mechanism **1100** includes yaw sensing magnet **406** and yaw Hall bar element **810**. Yaw Hall bar element **810** can measure the intensity and direction of the magnetic field of yaw sensing magnet **406** directed along yaw rotation axis **122**. In other words, Hall bar element **810** measures the intensity of magnetic field directed in the X direction only.

[0125] FIG. 11B shows a yaw rotation range β , a distance R_{YAW} between yaw Hall bar element **810** and yaw rotation axis **122**, and a trajectory **1108** of yaw sensing magnet **406** in the Y-Z plane. In some examples, yaw rotation range β is more than 10 degrees. The distance R_{YAW} is e.g. in the range of 2-5 mm. As an example, a case in which $\beta=40^\circ$ (meaning $\pm 20^\circ$ from the "zero" position) and $R_{YAW}=2.75$ mm is analyzed in FIGS. 11C-F below. As bottom actuated sub-assembly **220** is yaw-rotated, trajectory **1108** is in the Y-Z plane. Trajectory **1108** has an arc projection in the Y-Z plane (FIG. 11B) with length $\beta \times R_{YAW}$, where β is calculated in radians. Trajectory **1108** has a line shape projection on the X-Y plane (FIGS. 11C-E) with length $2 \times R_{YAW} \times \cos(\beta)$.

[0126] Yaw sensing magnet **406** is designed such that it has dimensions along Z-Y directions and such that it covers

trajectory **1108** from the top view (Y-Z plane). Yaw sensing magnet **406** can have different configurations.

[0127] FIGS. 11C-E show three different examples of magnetic configurations for yaw sensing magnet **406** in a cross section along X-Y plane of yaw sensing mechanism **1100**. In the configuration of FIG. 11C, yaw sensing magnet **406** has a rectangular cross section and the magnetic field of yaw sensing magnet **406** changes direction in the middle, e.g. the north magnetic field facing the positive X direction on the left side and the north magnetic field facing the negative X direction on the right side. In the configuration of FIG. 11D, yaw sensing magnet **406** has a rectangular cross section, and the magnetic field of yaw sensing magnet **406** is directed in the Y direction.

[0128] In the configuration shown in FIG. 11E, yaw sensing magnet **406** is characterized, along the Y direction, by a thinner cross section (the Y-X plane) in the middle and a thicker cross section on the sides. The varying width results in a varying distance between the sensor and the magnet positioned near the magnet (the sensor is located towards the negative X direction relative to the magnet) and thus a varying magnetic field along a projection of trajectory **1108** (line **1114**) on the Y-X plane. In some examples, the variation around the magnetic field is symmetrical around its center such that the thickness of the cross section of the magnet increases from a point substantially at its center towards each end of the magnet. Various examples of magnets constructed according to this principle are illustrated in FIGS. 11-i to 11-vi.

[0129] In addition, in some examples of the configuration of FIG. 11E (or any one of FIGS. 11-i to 11-vi), the magnetic field of yaw sensing magnet **406** changes direction in the middle, e.g. the north magnetic field faces the positive X direction on the left side and the north magnetic field faces the negative X direction on the right side. This results in zero magnetic field in the X direction in yaw hall bar element **810** facing the center of magnet **406** (along the center line).

[0130] FIG. 11F shows the magnetic field as a function of rotation along trajectory **1108**, for the 3 cases presented in FIGS. 11C-E. The projection of trajectory **1108** on plane X-Y (representing a lateral shift component of the magnet shift relative to the sensor) is shown by line **1110** in FIG. 11C, line **1112** in FIG. 11D and line **1114** in FIG. 11E. For line **1110**, the maximal magnetic field change along ± 20 degrees trajectory is ± 0.28 Tesla. However, most of the magnetic field change is obtained in a ± 7 degrees trajectory and the magnetic field gradient at higher yaw angles is lower than at lower yaw angles. This limits the ability to sense changes with high accuracy in high yaw angles. For projection line **1112**, the magnetic field gradient is more uniform along the trajectory of ± 20 , comparing to projection line **1110**. However, the magnetic field total change is limited to under ± 0.08 Tesla. For projection line **1114** the magnetic field gradient is more uniform than for both lines **1110** and **1112**, and the total magnetic field change is ± 0.25 Tesla, which can give high accuracy for position measurements. Thus, the magnetic configuration presented in FIG. 11E is superior for position sensing at large strokes, relative to the distance between the Hall bar and the corresponding magnet (e.g. in 1-4 mm range) using changes in magnetic field. Thus, by shaping the magnet with a variable thickness as shown in FIGS. 11E and 11-i to 11-vi, the range of detectable change in magnetic flux is increased. Accord-

ingly, the corresponding detectable range of relative (lateral) shift of the magnet and sensor is increased as well.

[0131] FIG. 12A-C shows a yaw magnetic actuation mechanism numbered **1200**. This actuation mechanism is for a second DOF. FIG. 12A show isometric view from one side, FIG. 12B shows isometric view from another side. Yaw magnetic actuation mechanism **1200** include yaw actuation magnet **404**, yaw coils **806** and ferromagnetic yoke **606**. FIG. 12C shows the magnetic field directions is Y-Z plane, along a cut A-B in FIG. 12A. Yaw actuation magnet **404** may be sintered such that its magnetic field is pointed toward negative Z direction. Each of coils **806** has one part (**1202**, **1204**) which is positioned in close proximity to yaw actuation magnet **404** (e.g. distance of 100-300 μm), and one part (**1206**, **1208**) which is further apart from yaw magnet **404**. Coils **806** may be connected in serial, such that the current in the two coil is equal. When current in **1202** is in the positive X direction the current in **1204** is also in the positive X direction, and the current in parts **1206** and **1208** is in the negative X direction. Upon driving a current in Yaw coils **806**, a Lorentz force is created on the yaw magnet **404**, according to $d\vec{F} = Id\vec{T} \times \vec{B}$. The direction of the magnetic field is demonstrated in FIG. 12C. The Lorentz force is translated into torque around yaw rotation axis **122**.

[0132] In some examples, an additional magnetic yoke **1302** may be located next to yaw magnet **404**. This yoke may increase the intensity of the magnetic field in coils **806** and increase the torque created by yaw magnetic actuation mechanism **1200**. FIG. 13 shows this case.

[0133] In some examples, rotation of the reflecting element around one or two axes moves the position of the camera FOV, wherein in each position a different portion of a scene is captured in an image having the resolution of the digital camera. In this way a plurality of images of adjacent camera FOVs (e.g. partially overlapping FOVs) are captured and stitched together (also referred to as “composite”) image having an overall image area of an FOV greater than digital camera FOV.

[0134] In some examples the digital camera can be a folded Tele camera configured to provide a Tele image with a Tele image resolution, the folded Tele camera comprising a Tele image sensor and its Tele lens assembly is characterized with a Tele field of view (FOV_T).

[0135] According to some examples, the folded Tele camera is integrated in a multiple aperture digital camera that comprises at least one additional upright Wide camera configured to provide a Wide image with a Wide image resolution, being smaller than the Tele image resolution, the Wide camera comprising a Wide image sensor and a Wide lens module with a Wide field of view (FOV_w); wherein FOV_T is smaller than FOV_w, wherein rotation of the OPFE moves FOV_T relative to FOV_w, for example as shown in of co-owned international patent applications PCT/IB2016/056060 and PCT/IB2016/057366.

[0136] The description of these PCT applications includes a Tele camera with an adjustable Tele field of view. As described in PCT/IB2016/056060 and PCT/IB2016/057366, rotation of the reflecting element around one or two axes moves the position of Tele FOV (FOV_T) relative to the Wide FOV (FOV_w), wherein in each position a different portion of a scene (within FOV_w) is captured in a “Tele image” with higher resolution. According to some examples, disclosed in PCT/IB2016/056060 and PCT/IB2016/057366, a plurality of Tele images of adjacent non-overlapping (or partially

overlapping) Tele FOVs are captured and stitched together to form a stitched (also referred to as “composite”) Tele image having an overall image area of an FOV greater than FOV_T . According to some examples, the stitched Tele image is fused with the Wide image generated by the Wide camera.

[0137] Digital camera **100** can further comprise or be otherwise operatively connected to a computer processing circuitry (comprising one or more computer processing devices), which is configured to control the operation of the digital camera (e.g. camera CPU). The processing circuitry, can comprise for example a controller operatively connected to the actuator of the rotating OPFE configured to control its operation.

[0138] The processing circuitry can be responsive to a command requesting an image with a certain zoom factor and control the operation of the digital camera for providing images having the requested zoom. As mentioned in applications PCT/IB2016/056060 and PCT/IB2016/057366, in some examples a user interface (executed for example by the processing circuitry) can be configured to allow input of user command being indicative of a requested zoom factor. The processing circuitry can be configured to process the command and provide appropriate instructions to the digital camera for capturing images having the requested zoom.

[0139] In some cases, if the requested zoom factor is a value between the FOV_w of a wide camera and FOV_T of a tele camera, the processing circuitry can be configured to cause the actuator of the reflecting element to move the reflecting element (by providing instruction to the controller of the actuator) such that a partial area of the scene corresponding to the requested zoom factor is scanned and a plurality of partially overlapping or non-overlapping Tele images, each having a Tele resolution and covering a portion of the partial area, are captured. The processing circuitry can be further configured to stitch the plurality of captured imaged together in order to form a stitched image (composite image) having Tele resolution and an FOV greater than the FOV_T of the digital camera. Optionally the stitched image can then be fused with the Wide image.

[0140] FIG. 14A is a schematic illustration of an example of a stitched image **1400** generated by scanning, capturing and stitching together four Tele images with FOV_T , compared to the FOV_w of a Wide camera, as in the example of FIG. 1C, where camera **190** represents a Wide FOV camera with a FOV_w coupled to folded Tele camera **100** with a FOV_T . In FIG. 14A, **1402** denotes FOV_w , **1404** denotes FOV_T at the center of FOV_w , and **1406** indicates the size of the requested zoom factor. In the illustrated example, four partially overlapping Tele images **1408** are captured.

[0141] Notably, the overall area of captured Tele images **1408** is greater than the area of the zoom image **1406** in the requested zoom. The central part of the captured Tele images is extracted (e.g. by the computer processing circuitry as part of the generation of the stitched image) for generating stitched image **1400**. This helps to reduce the effect of image artefacts resulting from transition from an image area covered by one image to an image area covered by a different image.

[0142] FIG. 14B is a schematic illustration of an example of a stitched image **1400'** generated by capturing and stitching together six Tele images. FIG. 14C is a schematic illustration of an example of a stitched image **1400''** generated by capturing and stitching together nine Tele images. The same principles described with reference to FIG. 14A

apply to FIGS. 14B and 14C. Notably, the output image resulting from the stitching can have a different width to height ratio than the single image proportion. For example, as illustrated in FIG. 14B, a single image can have a 3:4 ratio and the output stitched image can have a 9:16 ratio.

[0143] It is noted that image stitching per se is well known in the art and therefore it is not explained further in detail.

[0144] An alternative design of the top and bottom actuated sub-assemblies described above is now described with reference to FIGS. 15A-15E. Notably, as would be apparent to any person skilled in the art, unless stated otherwise, some of the details described above with reference to the previous figures can also be applied to the example described with reference to FIGS. 15A-15E.

[0145] According to this design, a single magnet **1510** serves for three purposes: 1) as a pre-load magnet in magnet-yoke pair, dedicated for fastening the bottom actuated sub-assembly to the stationary sub-assembly; 2) as a yaw actuation magnet dedicated for generating yaw movement of bottom actuated sub-assembly; and 3) as a yaw sensing magnet for sensing yaw movement.

[0146] FIG. 15A shows a magnet **1506** and a yoke (e.g. a ferromagnetic plate such as iron) **1504**, where the magnet and yoke are pulled together by pre-load force (indicated by black double head arrow) and thus fasten top actuated sub-assembly **210** to bottom actuated sub-assembly **220**. In some examples, magnet **1506** and yoke **1504** are positioned substantially at the center (relative to the Y axis direction) of the top actuated sub-assembly. Pitch rotation axis relative to the bottom actuated sub-assembly is demonstrated by the circular arrow **1508**.

[0147] FIG. 15B shows top and bottom actuated sub-assemblies in isometric view. FIG. 15B illustrates magnet **1510** located at the internal part of bottom actuated sub-assembly, sensor **1512** and a coil **1514**, which is located at the back of bottom actuated sub-assembly (in the positive Z direction relative to magnet **1510**). According to one example, a single coil can be used for actuation.

[0148] As shown in FIG. 15C, yoke **1516**, is fastened to the stationary sub-assembly. Magnet **1510** and yoke **1516** are attracted by pre-load force to thereby fasten bottom actuated sub-assembly **220** to stationary sub-assembly **230**. Coil **1514** is positioned in close proximity to yaw actuation magnet **1510** (e.g. distance of 100-300 μm). When current is applied in coil **1514**, a Lorentz force is created on yaw magnet **1510** according to $d\vec{F} = Id\vec{T} \times \vec{B}$, where the Lorentz force is translated into torque around yaw rotation axis **122** (not shown) as explained above.

[0149] Magnet **1510** moves along the yaw direction as part of the bottom actuated sub-assembly. In addition of being more compact, this type of yaw actuation mechanism also provides better efficiency, as it does not generate force in the opposite direction to the desired yaw movement.

[0150] As explained above, in some examples top actuated sub-assembly **210** includes an OPFE holder (or carrier) **302** and bottom actuated sub-assembly includes a middle moving frame **402**. According to an example, yoke **1504** is attached (e.g. glued) to the holder and the first magnet-yoke pair (**1506-1504**) pulls the OPFE holder to the middle moving frame. Alternatively, the position of the magnet and yoke can be switched. The stationary sub-assembly includes a base and the yoke is attached to the based in a manner that the second magnet-yoke pair (**1510-1516**) pulls the middle

moving frame to the base. Also, in an example coil **1514** and sensor **1512** are fixed (e.g. glued) to the base.

[0151] According to some examples of the presently disclosed subject matter yaw magnet **1510**, which also serves as yaw sensing magnet, is made to have an increased detection range. To this end, magnet **1510** is made to have a single magnetic polarization direction as indicated by the back arrow extending from the south pole to the north pole of magnet **1510** shown in FIG. **15D**. The directions of the magnetic field lines are indicated by arrows a-e in FIG. **15D** and in more detail in FIG. **15E**, which is a top view of magnet **1510**. As indicated by arrows a-e, as a result of the single magnetic polarization direction of magnet **1510**, the angle of the magnetic field relative to the magnet surface changes continuously along the length of magnet. The illustration shows the angle changing from being substantially perpendicular in the positive direction at one end, to being in a parallel direction at the magnet center and to being substantially perpendicular in the negative direction at the other one. Since the relative changes (e.g. of magnetic flux) are detectable at each of the points where change in the direction of the magnetic field occurs, yaw movement of the magnet relative to sensor **1512** can be detected over an increased range. The increased detection range of the yaw magnet as disclosed herein enables to use the same magnet for both actuation and sensing, eliminating the need for two separate magnets.

[0152] Note that unless stated otherwise terms such as “first” and “second” as used herein are not meant to imply a particular order but are only meant to distinguish between two elements or actions in the sense of “one” and “another”.

[0153] While this disclosure has been described in terms of certain embodiments and generally associated methods, alterations and permutations of the embodiments and methods will be apparent to those skilled in the art. The disclosure is to be understood as not limited by the specific embodiments described herein, but only by the scope of the appended claims.

[0154] All references mentioned in this specification are herein incorporated in their entirety by reference into the specification, to the same extent as if each individual reference was specifically and individually indicated to be incorporated herein by reference. In addition, citation or identification of any reference in this application shall not be construed as an admission that such reference is available as prior art to the present application.

What is claimed is:

1. A folded camera, comprising:
 an optical path folding element (OPFE),
 an image sensor; and
 a pitch actuation and sensing mechanism configured to rotate the OPFE over an extended rotation range around a pitch rotation axis relative to the image sensor,
 wherein the pitch actuation and sensing mechanism includes a pitch magnet,
 wherein the pitch magnet has a mechanical symmetry plane, and
 wherein the pitch magnet is fabricated such that a magnetic field direction changes along the mechanical

symmetry plane, and wherein the pitch magnet has a non-rectangular shape in at least one dimension.

2. The folded camera of claim 1, wherein the pitch actuation and sensing mechanism includes a pitch coil and a pitch Hall bar.

3. The folded camera of claim 1, wherein the extended rotation range is equal to or greater than ± 5 degrees.

4. The folded camera of claim 1, wherein the extended rotation range is equal to or greater than ± 10 degrees.

5. The folded camera of claim 1, wherein the extended rotation range is between ± 15 -40 degrees.

6. The folded camera of claim 1, wherein the pitch actuation and sensing mechanism is included in an actuator, and wherein the actuator is configured to rotate the OPFE over an extended rotation range around a second rotation axis relative to the image sensor.

7. The folded camera of claim 6, wherein the extended rotation range around the pitch rotation axis is different from the extended rotation range around the second rotation axis.

8. The folded camera of claim 6, wherein the extended rotation range is equal to or greater than ± 5 degrees around the pitch rotation axis and the second rotation axis.

9. The folded camera of claim 6, wherein the extended rotation range is equal to or greater than ± 10 degrees around the pitch rotation axis and the second rotation axis.

10. The folded camera of claim 6, wherein the extended rotation range is between ± 15 -40 degrees around the pitch rotation axis and the second rotation axis.

11. The folded camera of claim 6, further comprising a lens module accommodating a plurality of lens elements along a lens optical axis, wherein the OPFE redirects light that enters the folded camera from the direction of a view section along a first optical path toward a second optical path along the lens optical axis, and wherein the actuator further comprises a pitch magnet located at a side of the OPFE that is opposite to a side facing the view section.

12. The folded camera of claim 1, wherein the folded camera also includes a lens module, and wherein the lens module comprises 3 to 7 lens elements.

13. The folded camera of claim 1, wherein the folded camera has a fixed focal length.

14. The folded camera of claim 1, wherein the folded camera is an auto-focus camera.

15. The folded camera of claim 1, wherein the extended rotation range is used for performing optical image stabilization (OIS).

16. The folded camera of claim 1, wherein the OPFE is a prism.

17. The folded camera of claim 1, included in a mobile device.

18. The folded camera of claim 17, wherein the mobile device also includes an upright camera.

19. The folded camera of claim 17, wherein the mobile device is a smartphone.

20. The folded camera of claim 17, wherein the mobile device is a tablet.

* * * * *