



US 20240124342A1

(19) **United States**

(12) **Patent Application Publication**
MASTEN, JR.

(10) **Pub. No.: US 2024/0124342 A1**

(43) **Pub. Date: Apr. 18, 2024**

(54) **APPARATUS FOR FORMING SHAPED GLASS**

Publication Classification

(71) Applicant: **James William MASTEN, JR.,**
Everett, WA (US)

(72) Inventor: **James William MASTEN, JR.,**
Everett, WA (US)

(21) Appl. No.: **18/392,563**

(22) Filed: **Dec. 21, 2023**

(51) **Int. Cl.**
C03B 18/16 (2006.01)
C03B 23/025 (2006.01)
C03B 23/035 (2006.01)
C03B 25/02 (2006.01)
C03B 27/044 (2006.01)

(52) **U.S. Cl.**
CPC *C03B 18/16* (2013.01); *C03B 23/0252*
(2013.01); *C03B 23/0357* (2013.01); *C03B*
25/025 (2013.01); *C03B 27/044* (2013.01)

Related U.S. Application Data

(63) Continuation of application No. 17/942,096, filed on Sep. 9, 2022, now Pat. No. 11,851,357, which is a continuation-in-part of application No. 17/866,422, filed on Jul. 15, 2022, now Pat. No. 11,821,689, which is a continuation-in-part of application No. 17/525,818, filed on Nov. 12, 2021, now Pat. No. 11,390,552.

(60) Provisional application No. 63/242,350, filed on Sep. 9, 2021, provisional application No. 63/242,186, filed on Sep. 9, 2021.

(57) **ABSTRACT**

A sheet of glass can be formed in a batch process by introducing molten glass onto a layer of molten tin within a tank. The tank may be outfitted with infrared emitters to control the amount of heat delivered to the tank while the sheet of glass is formed. A lower surface of the tank can have a three-dimensional shape, and the molten tin may be removed from the tank while the sheet of glass is ductile so that the sheet of glass is molded by the three-dimensional shape, thereby producing a shaped sheet of glass. The delivery of infrared energy to the tank may be facilitated by one or more ceramic glass surface.

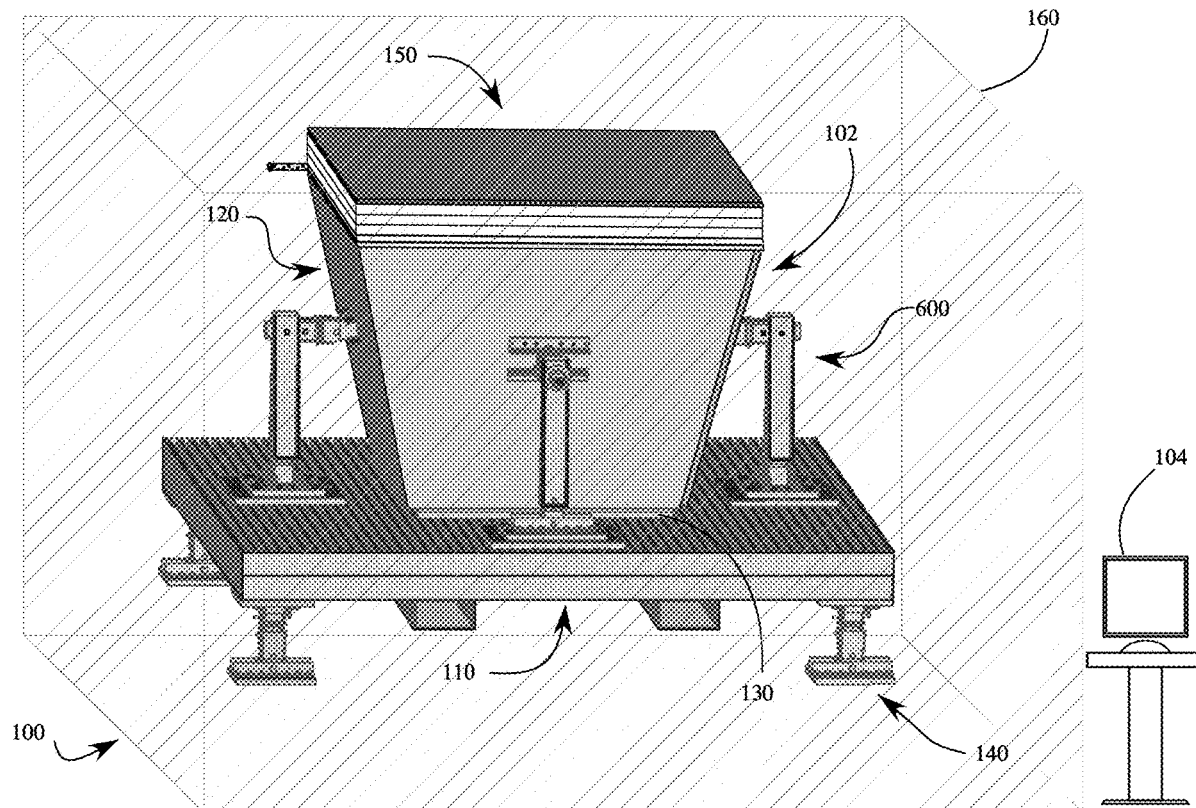

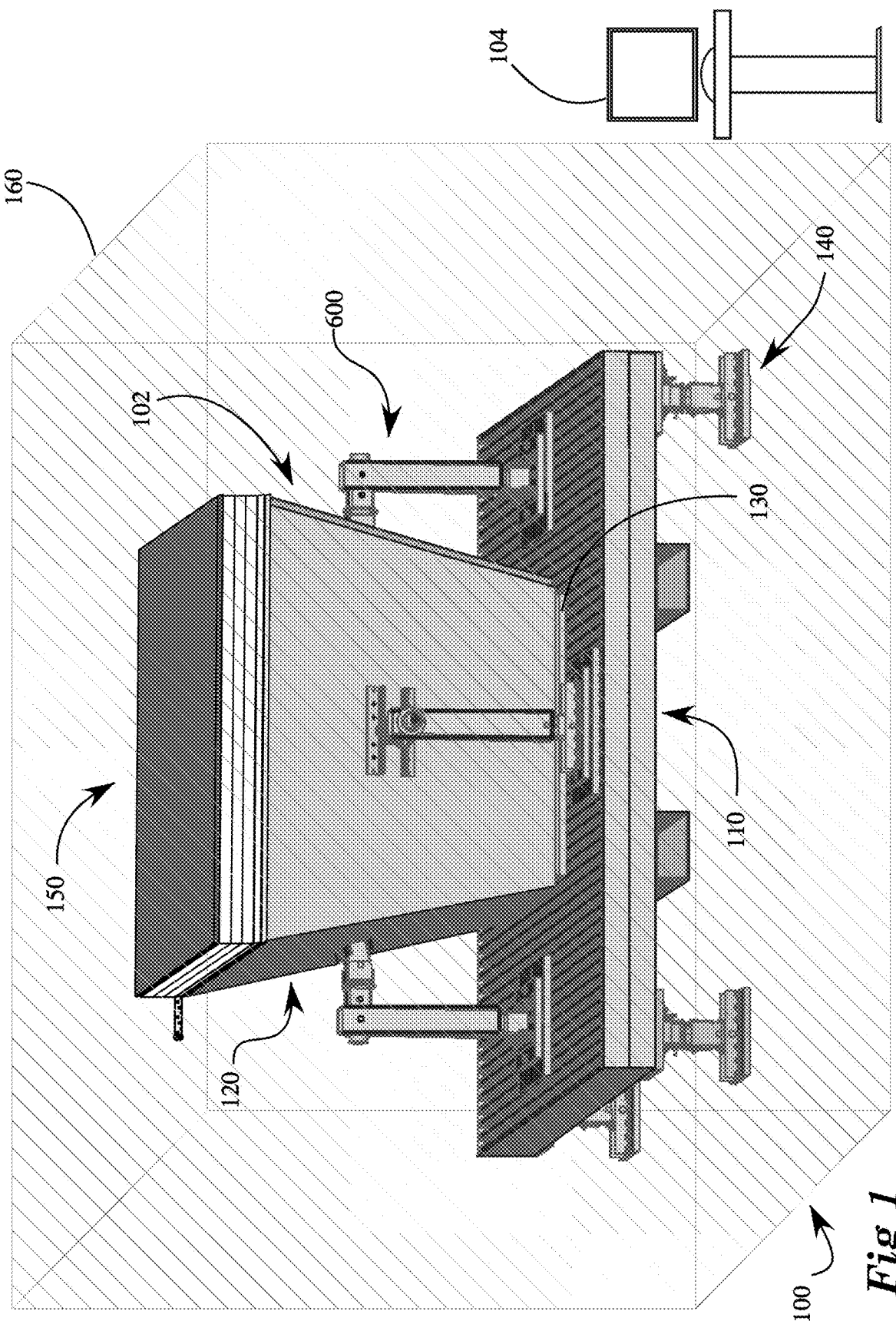

Fig 1

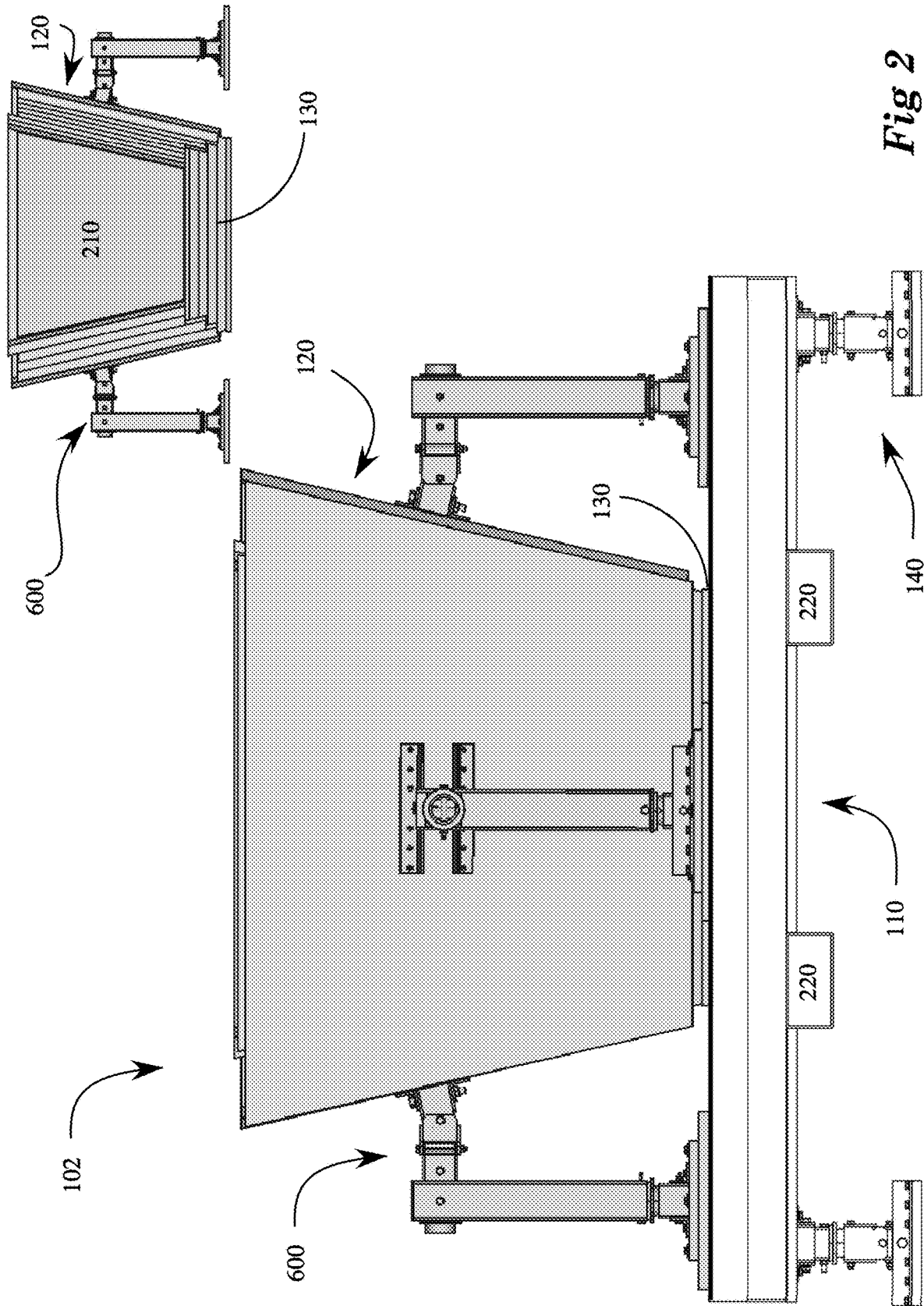
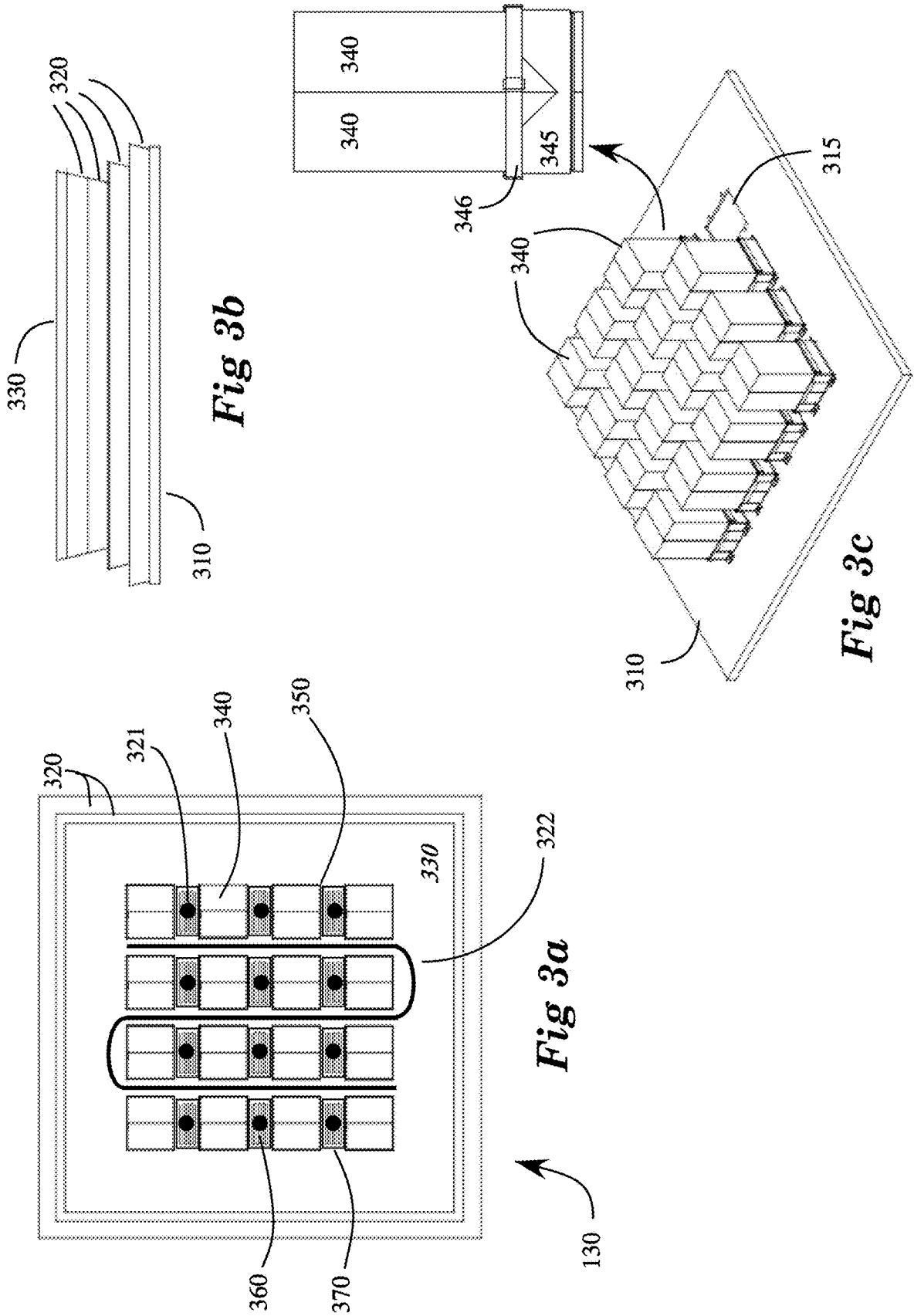
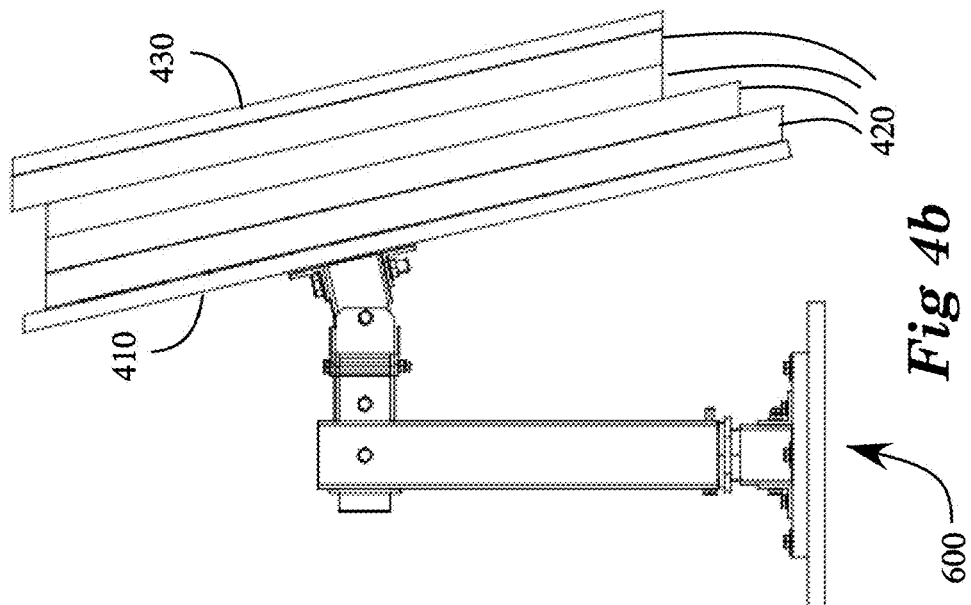
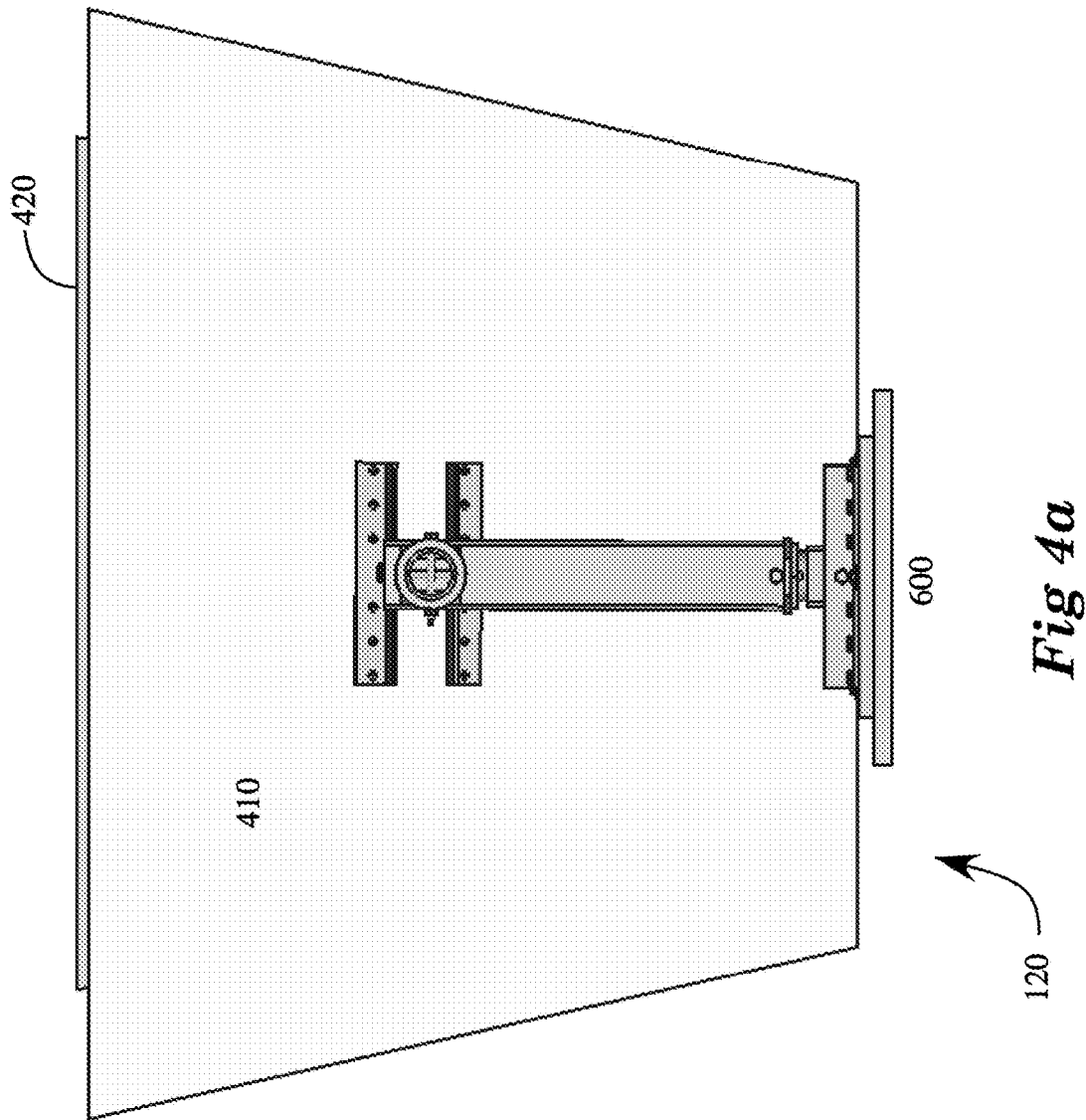

Fig 2





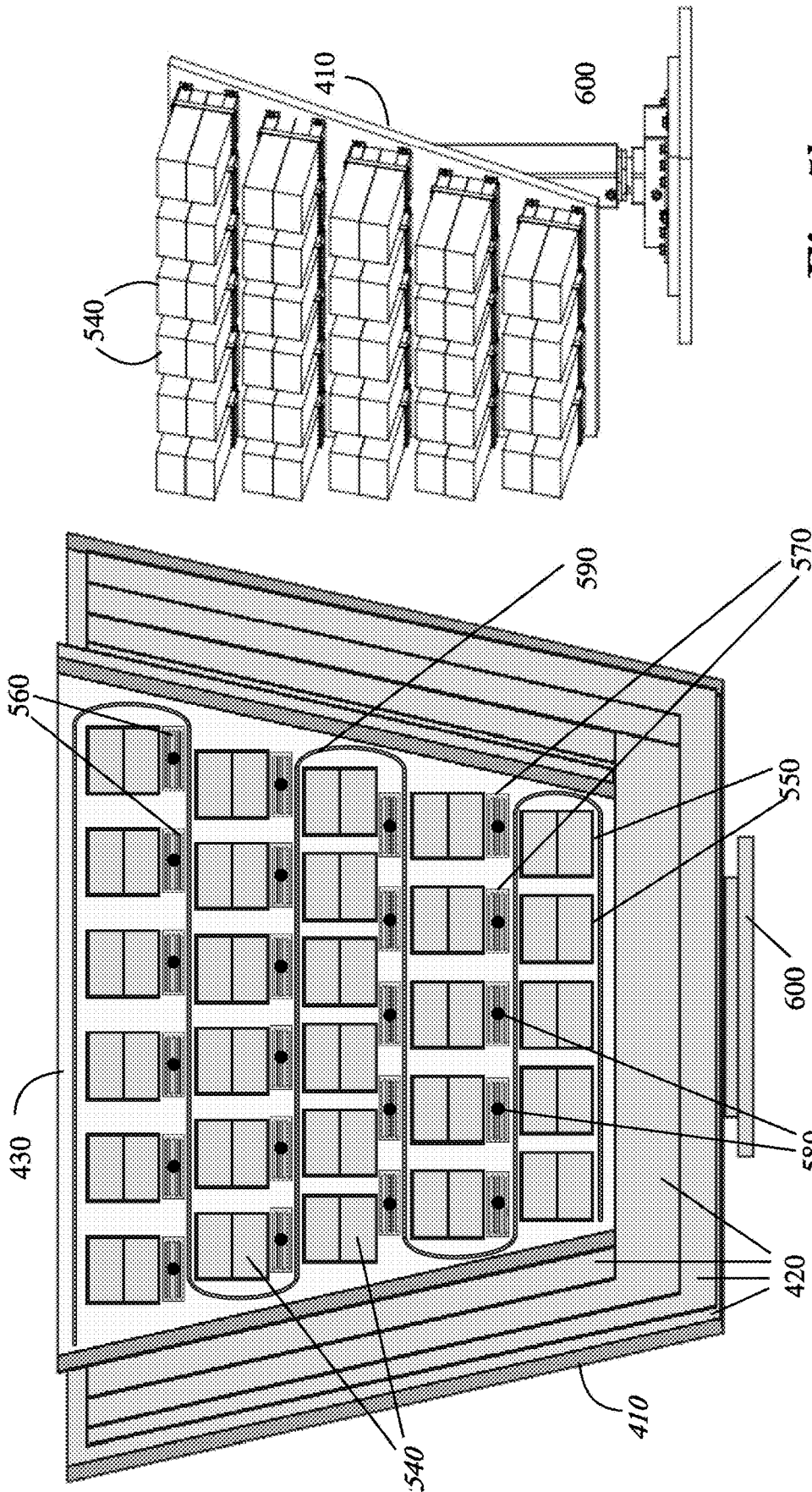
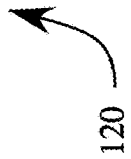

Fig 5b

Fig 5a



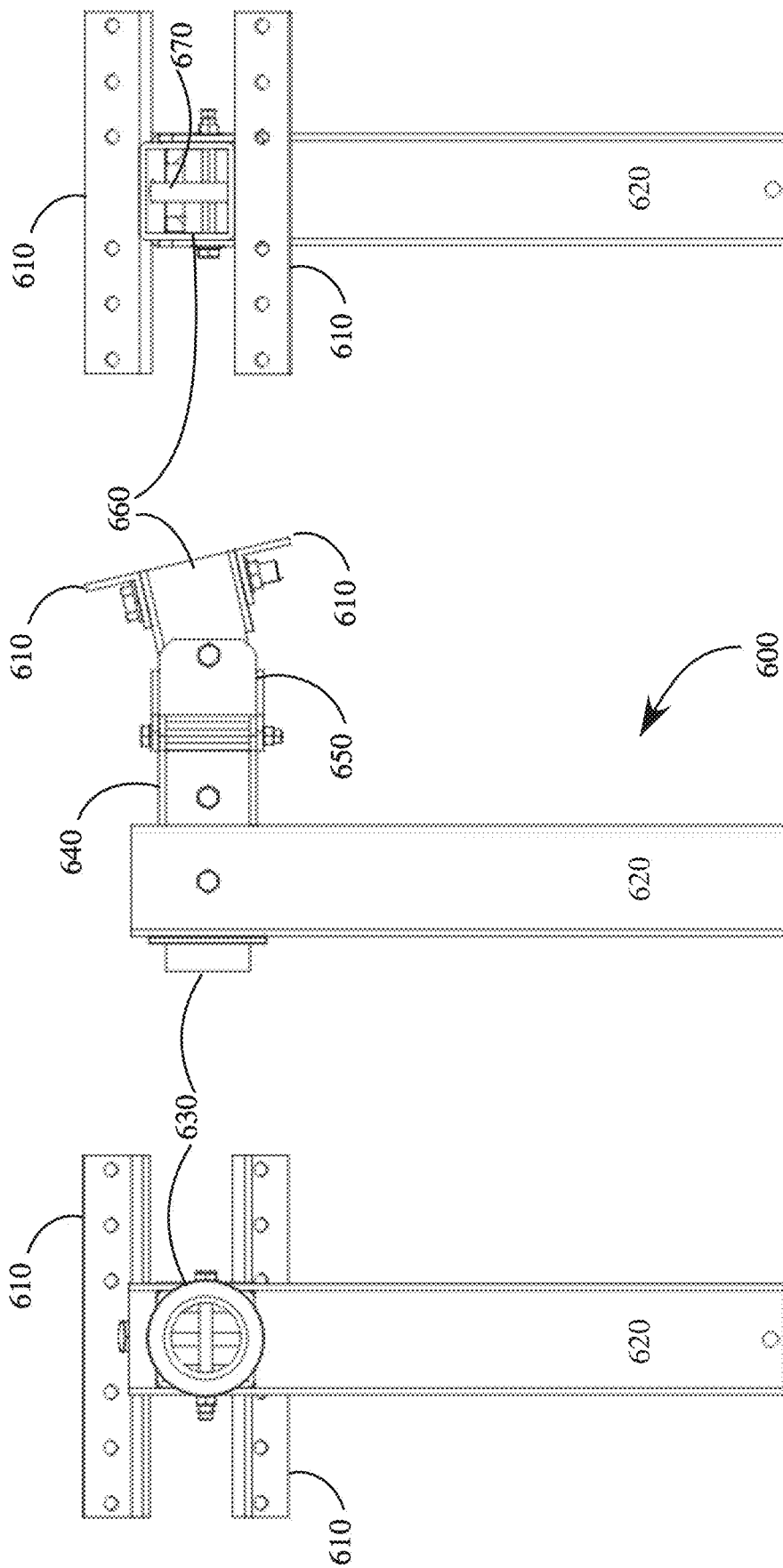

Fig 6c

Fig 6b

Fig 6a

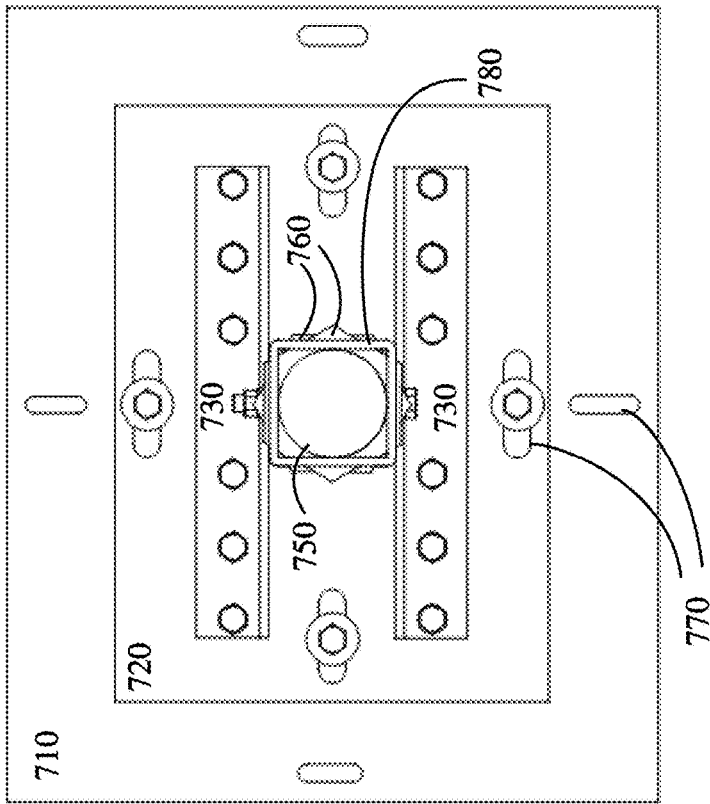

Fig 7c

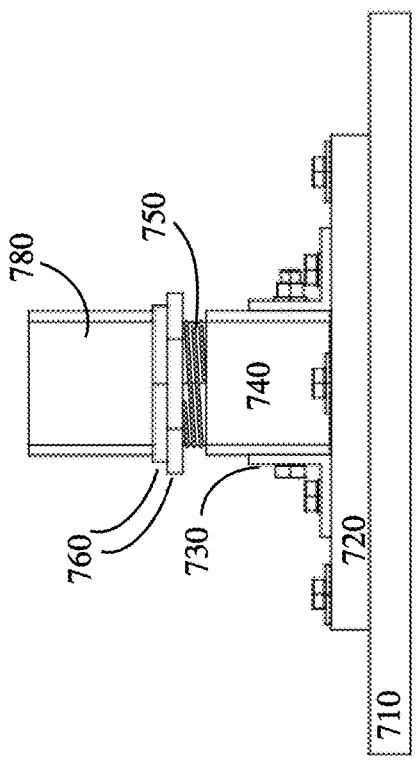

Fig 7a

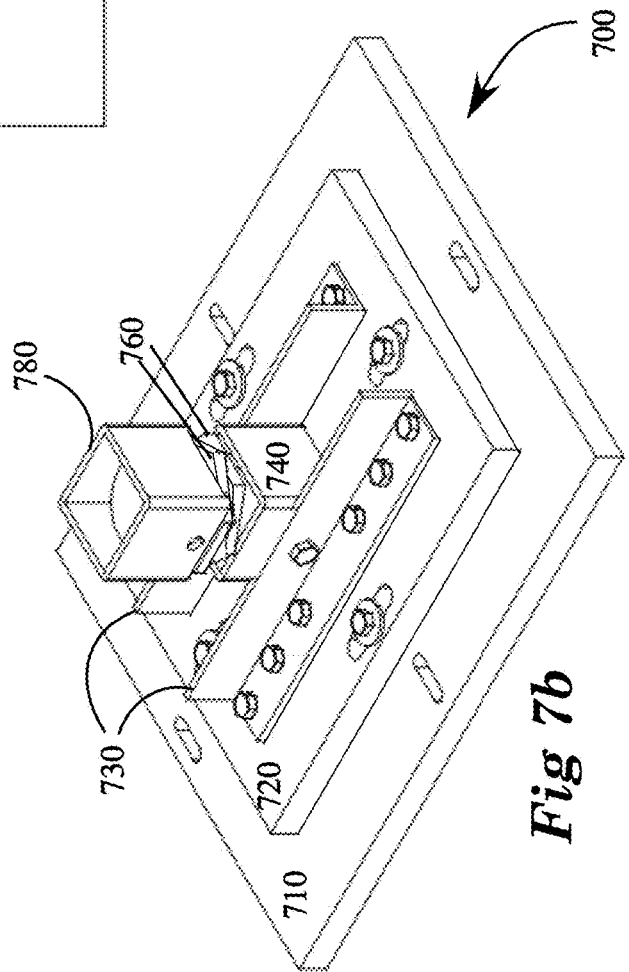
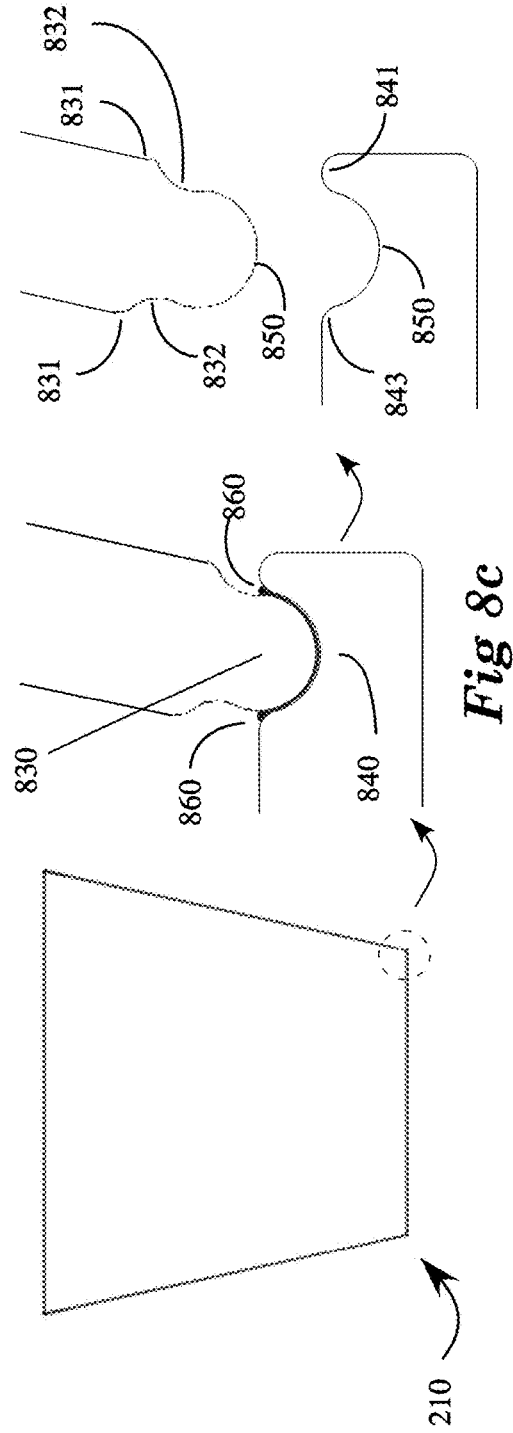
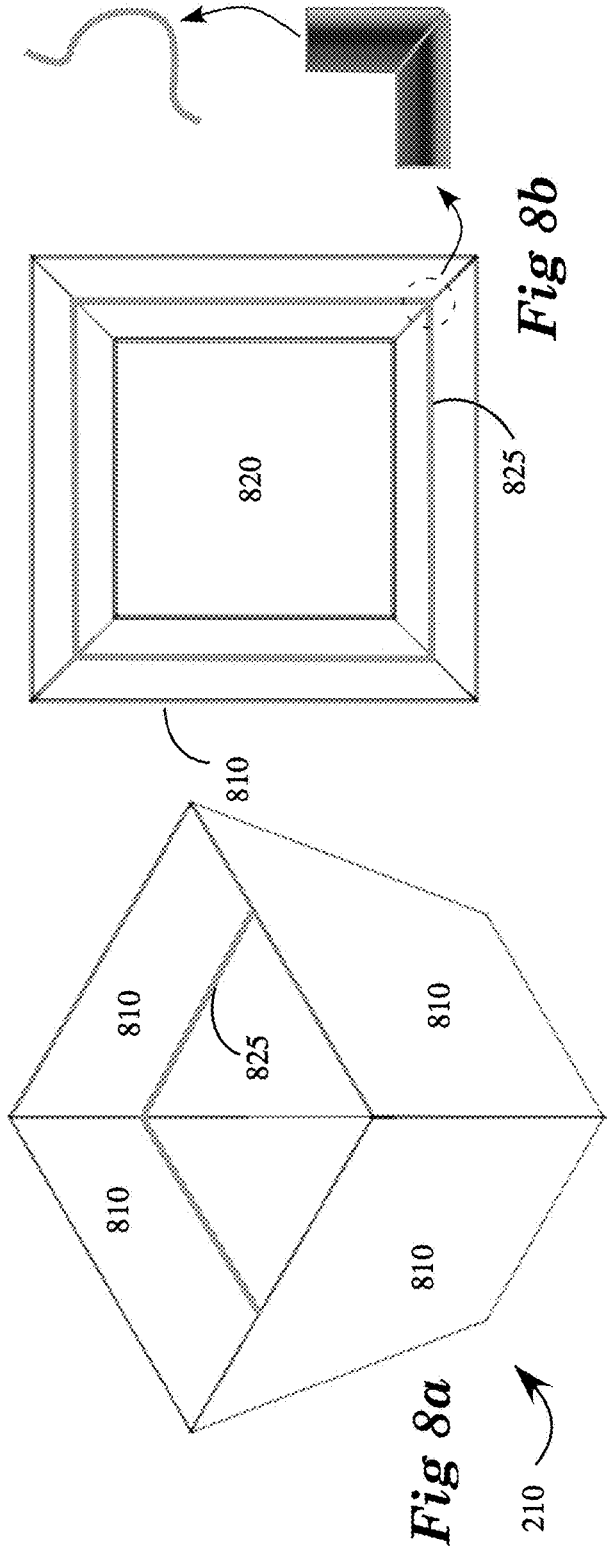

Fig 7b



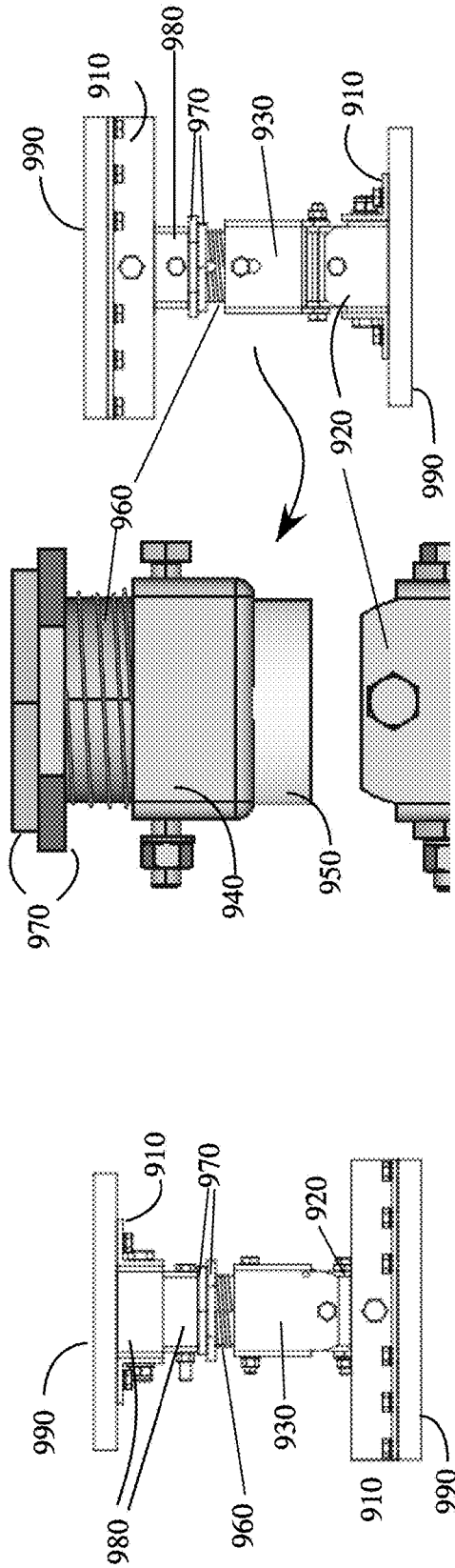

Fig 9b

Fig 9a

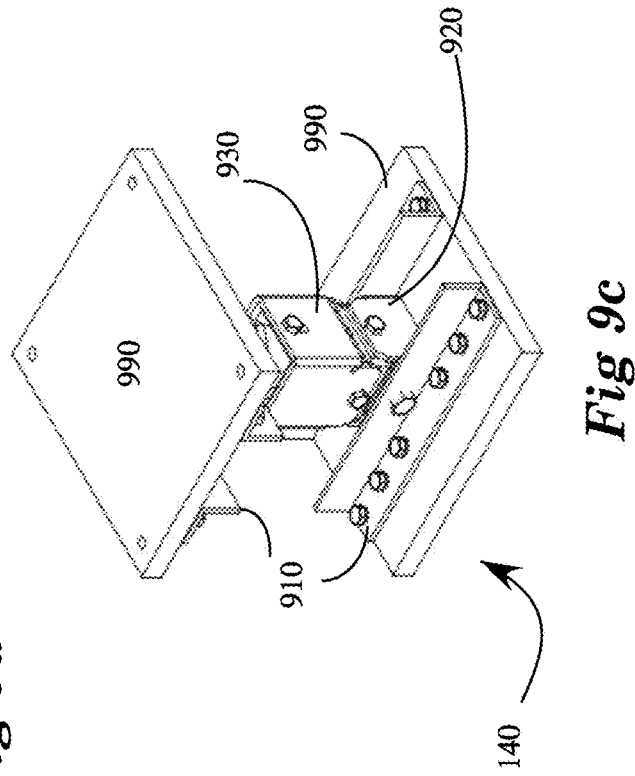

Fig 9c

140

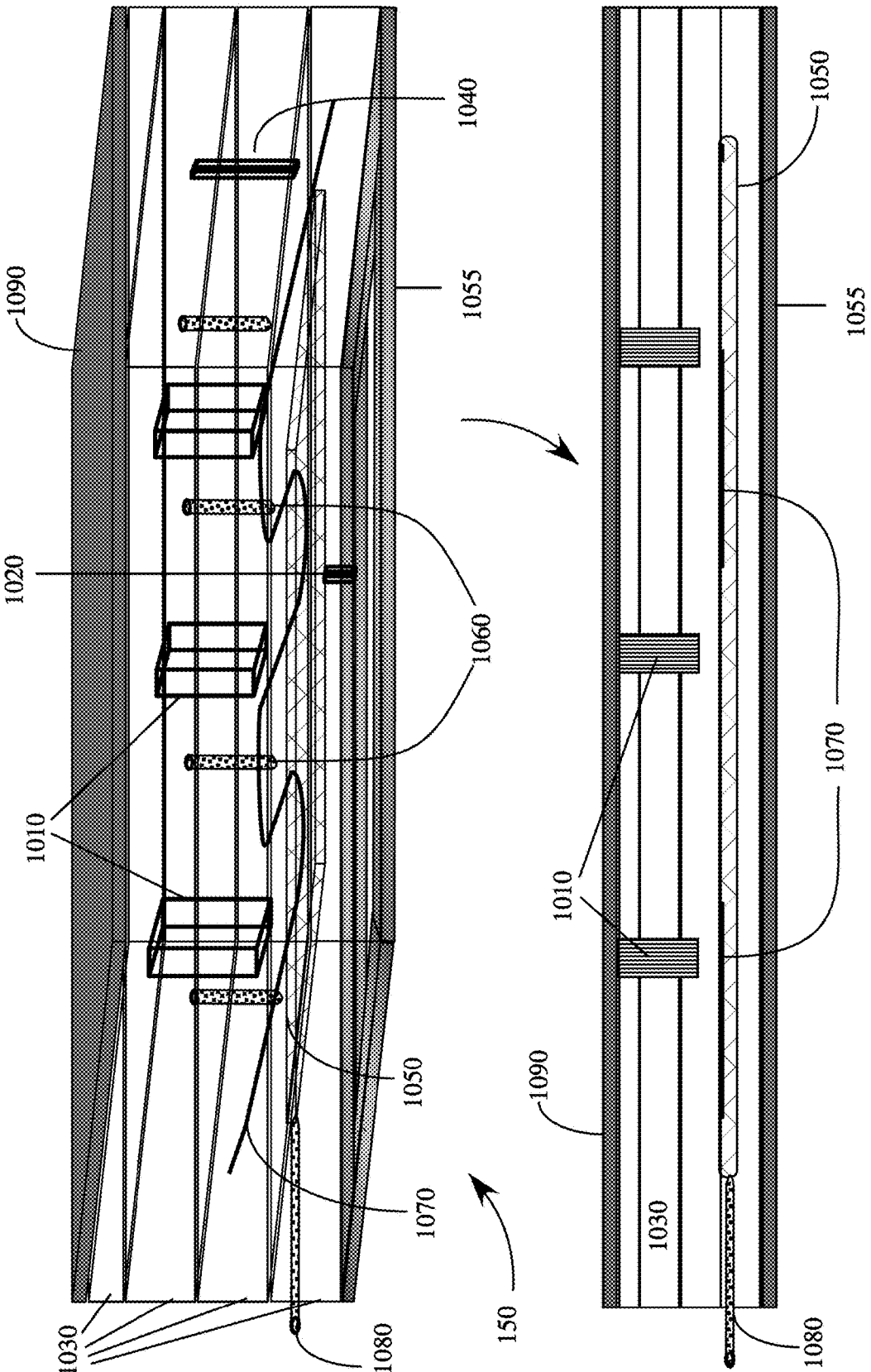

Fig 10

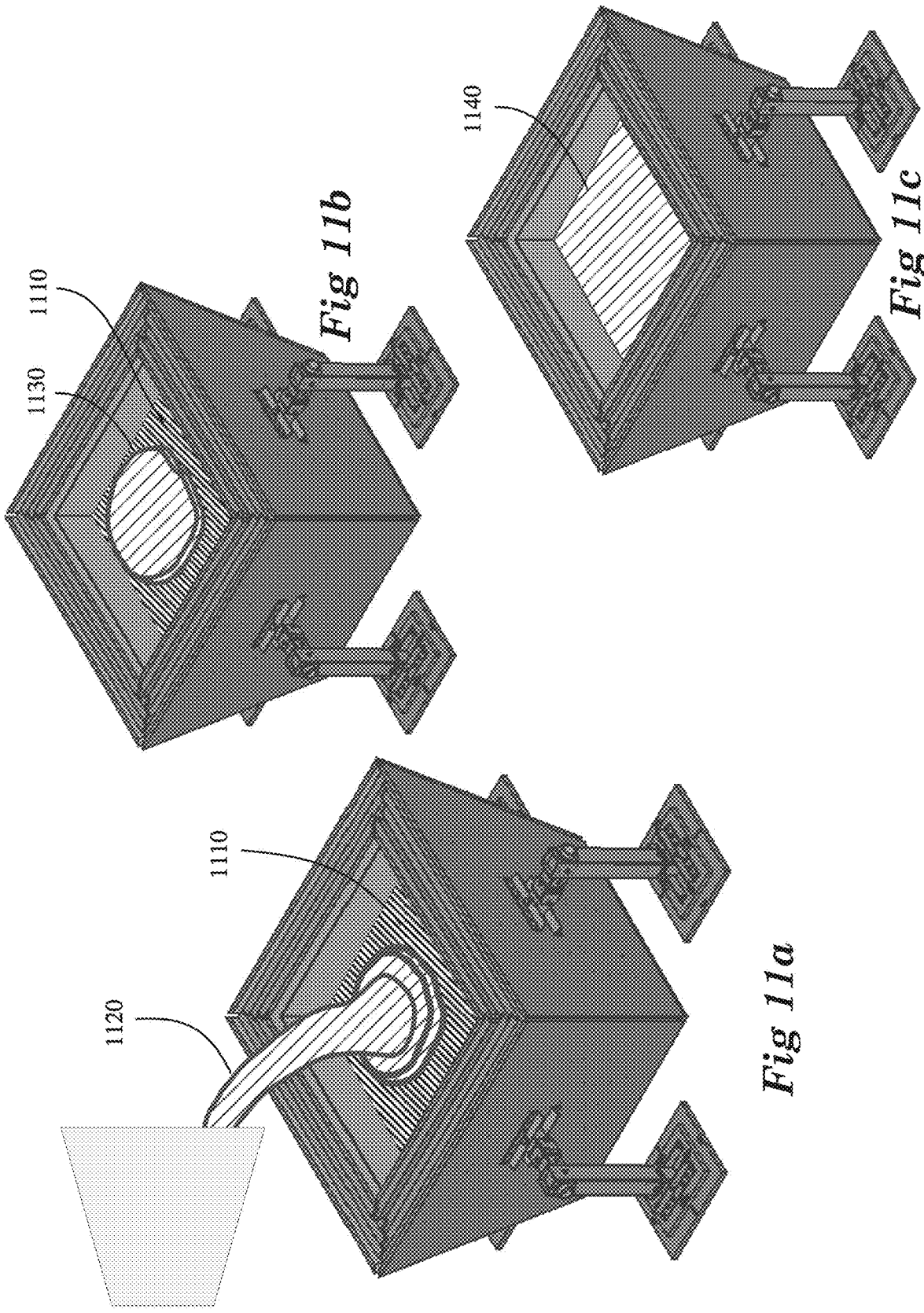

Fig 11b

Fig 11c

Fig 11a

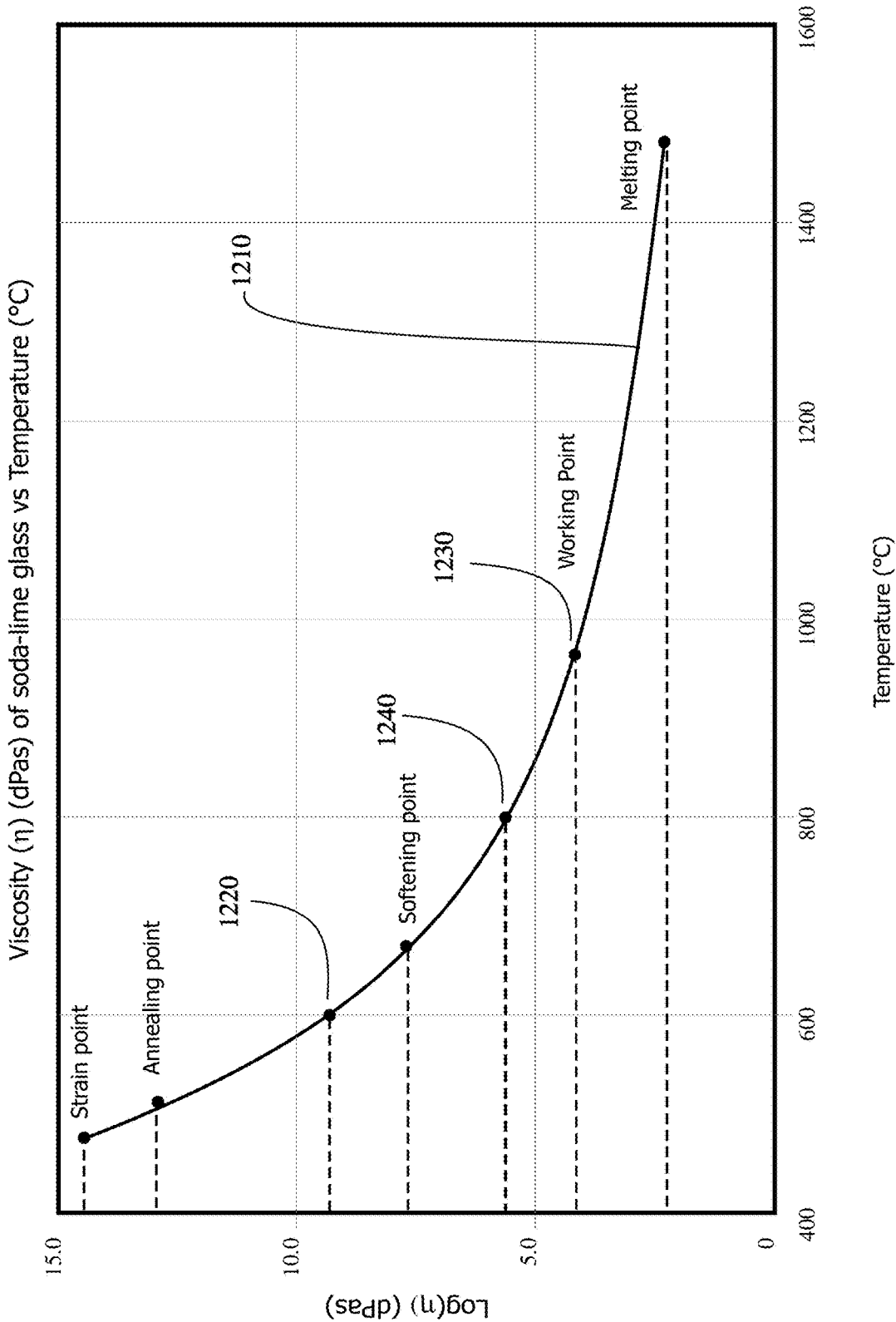

Fig 12

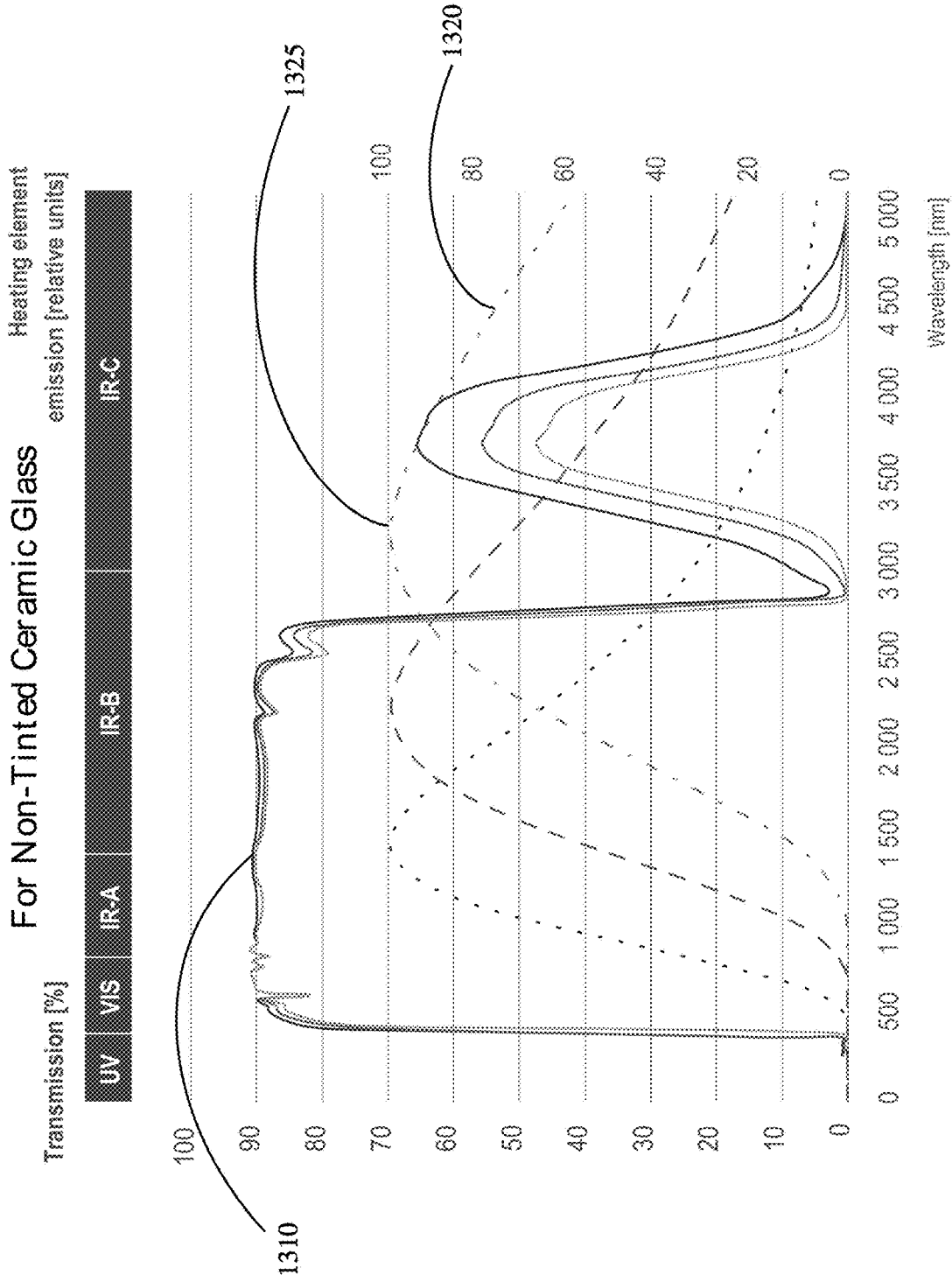

Fig 13

For Opaque Ceramic Glass

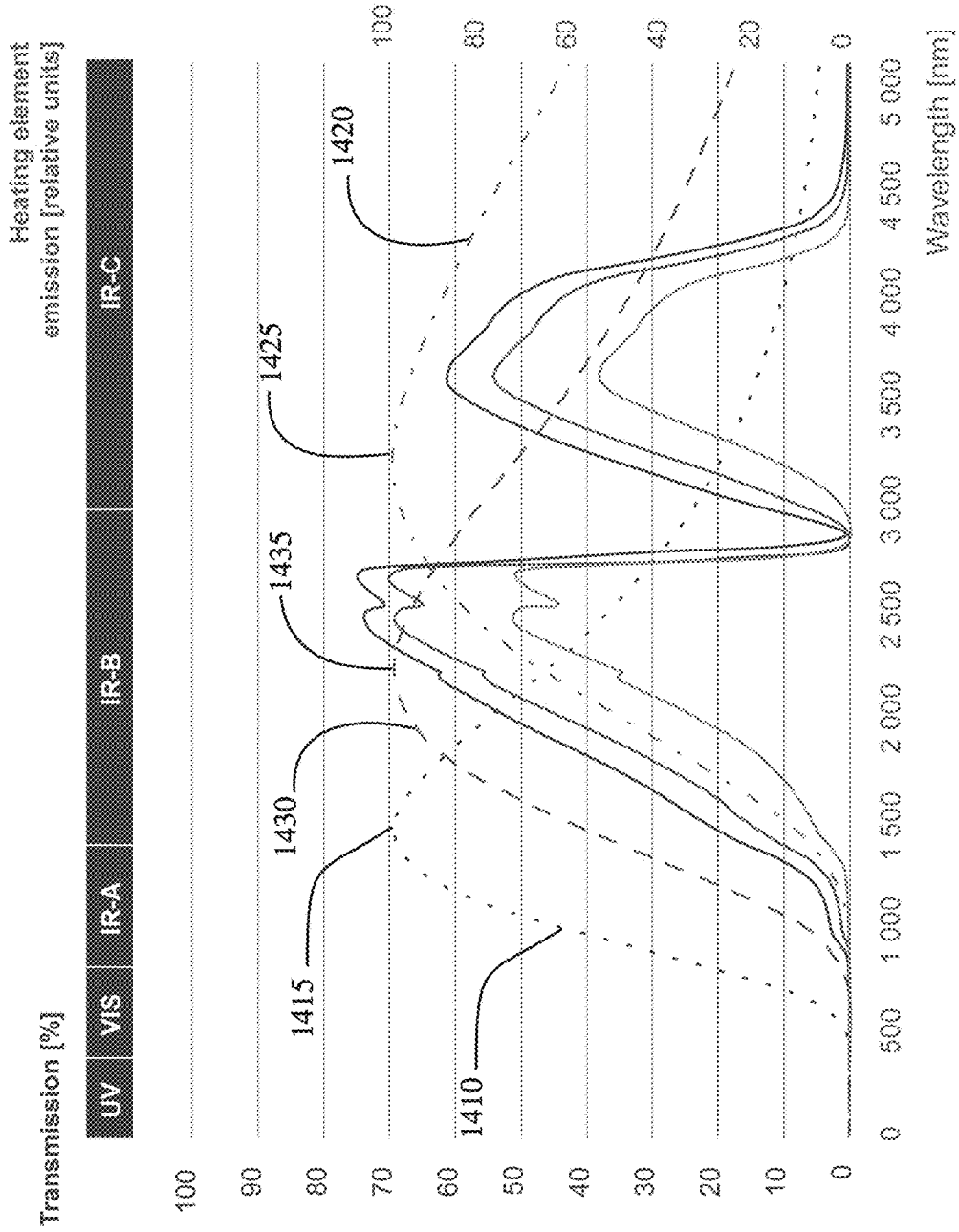

Fig 14

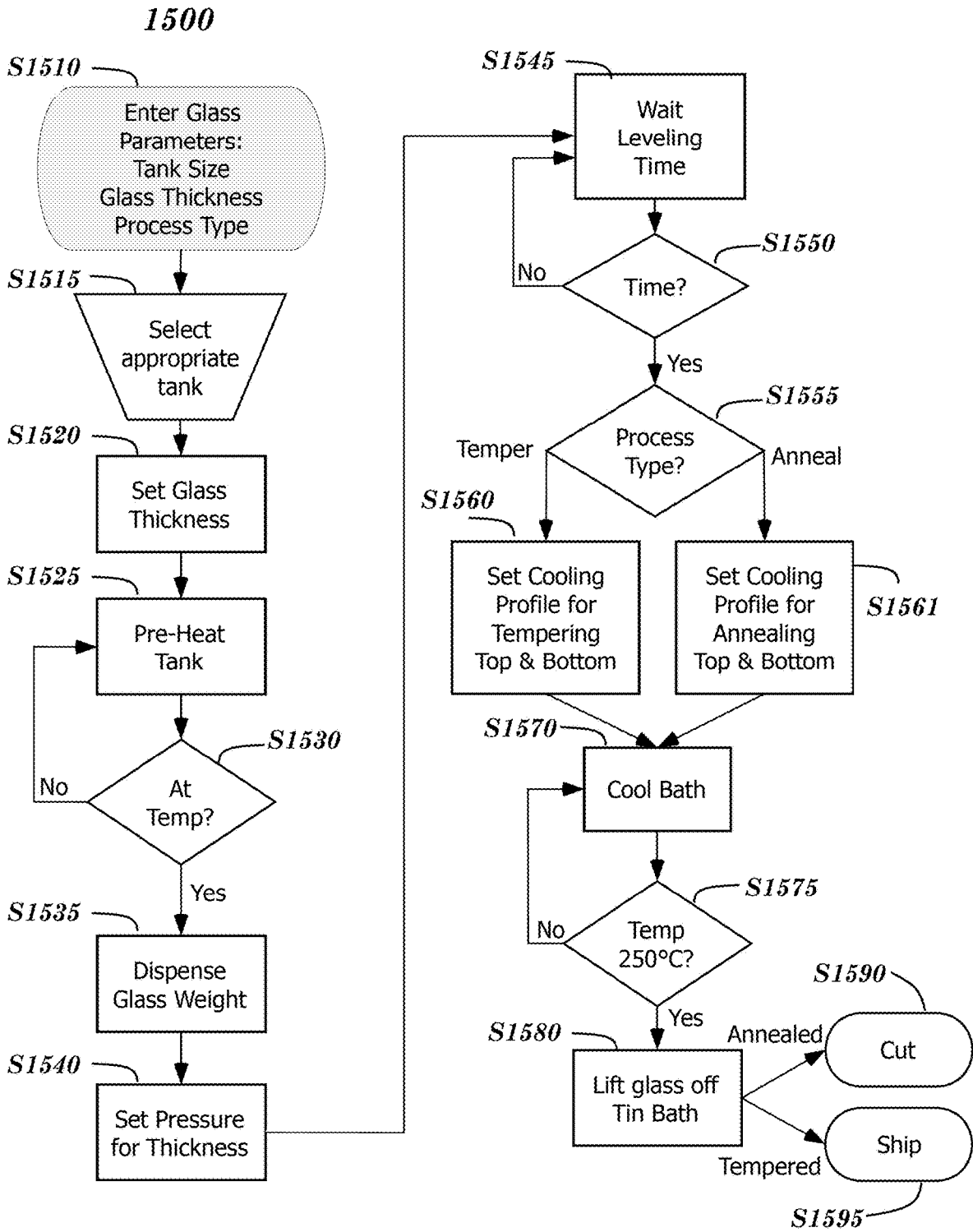

Fig 15

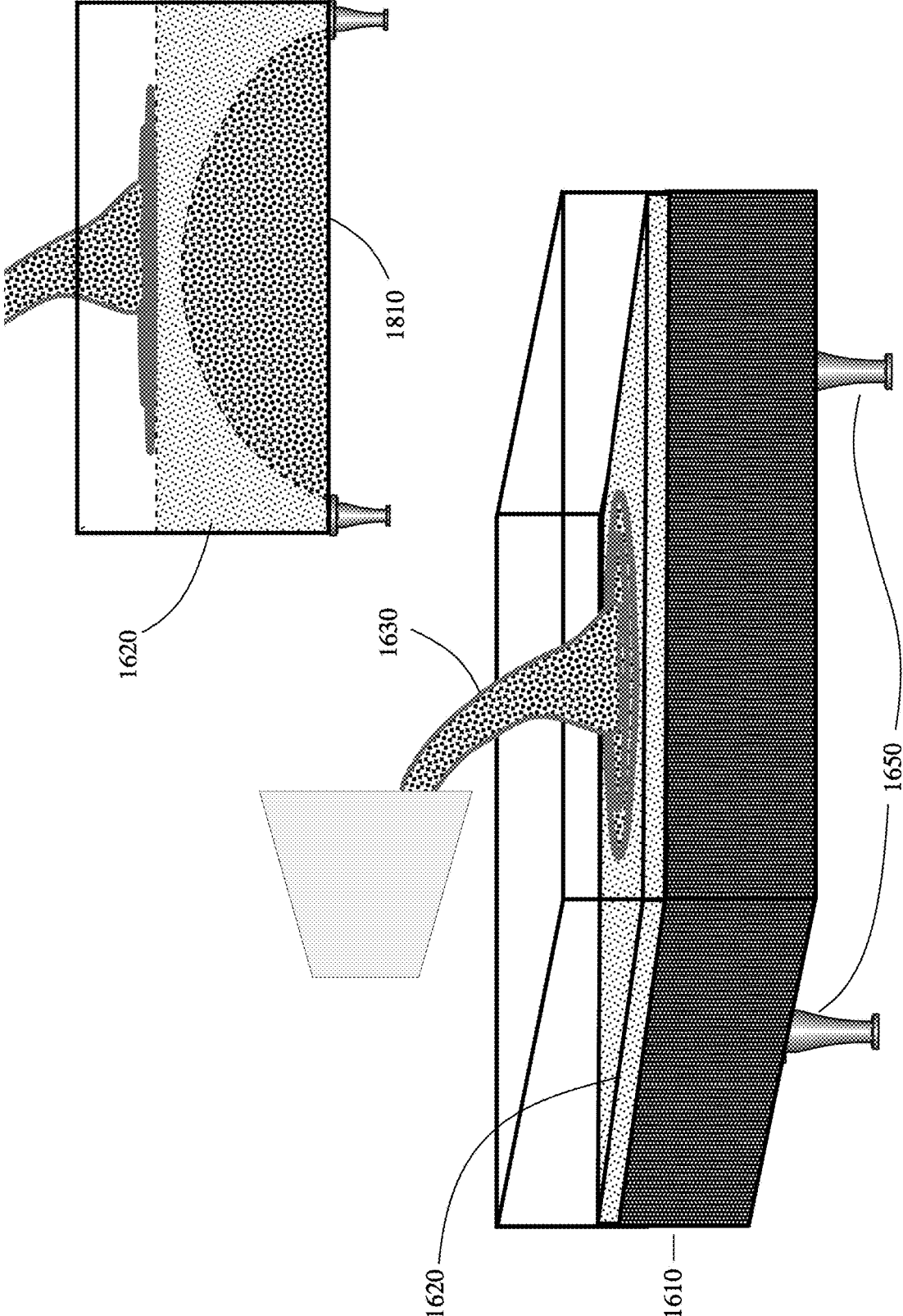

Fig 16

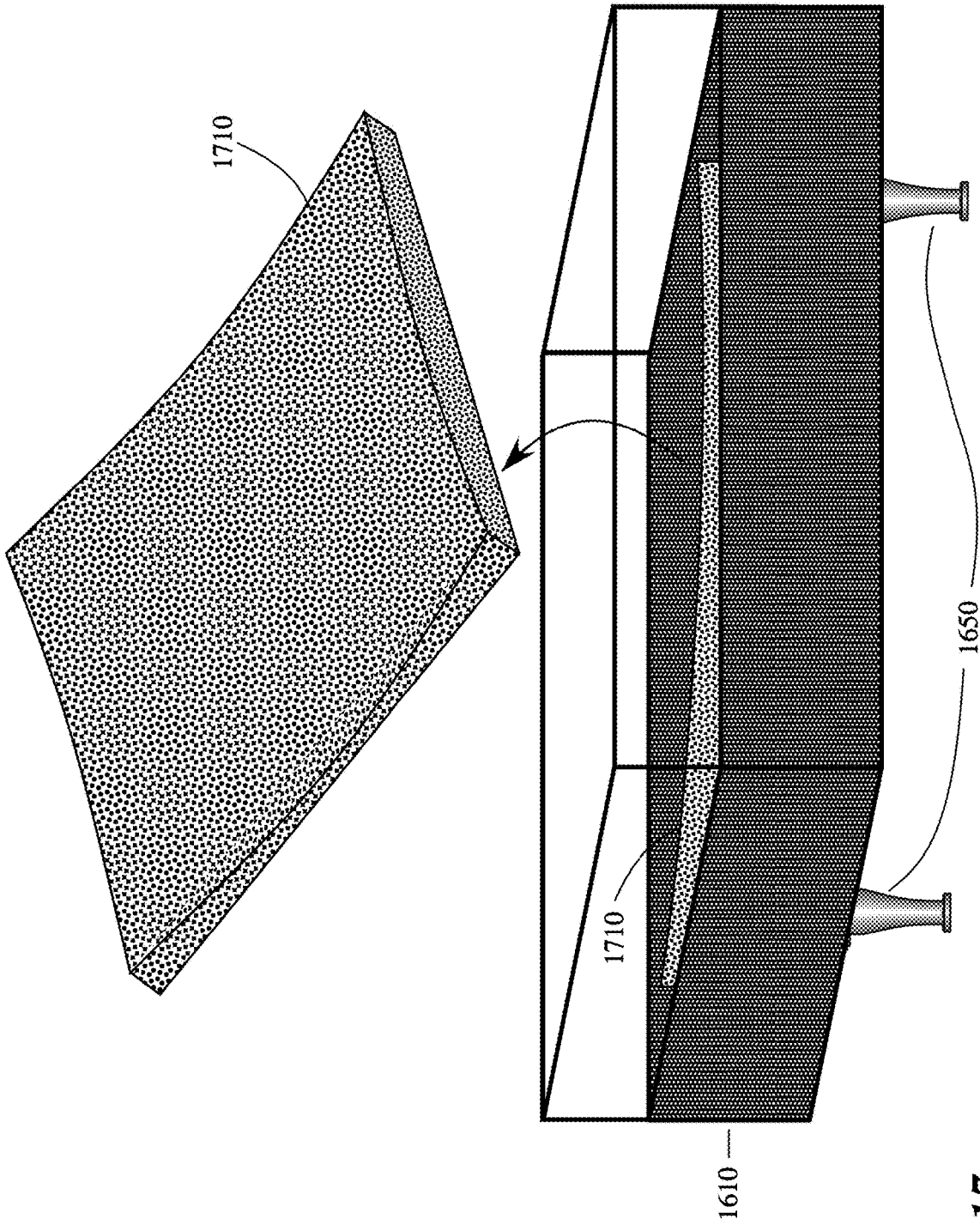

Fig 17

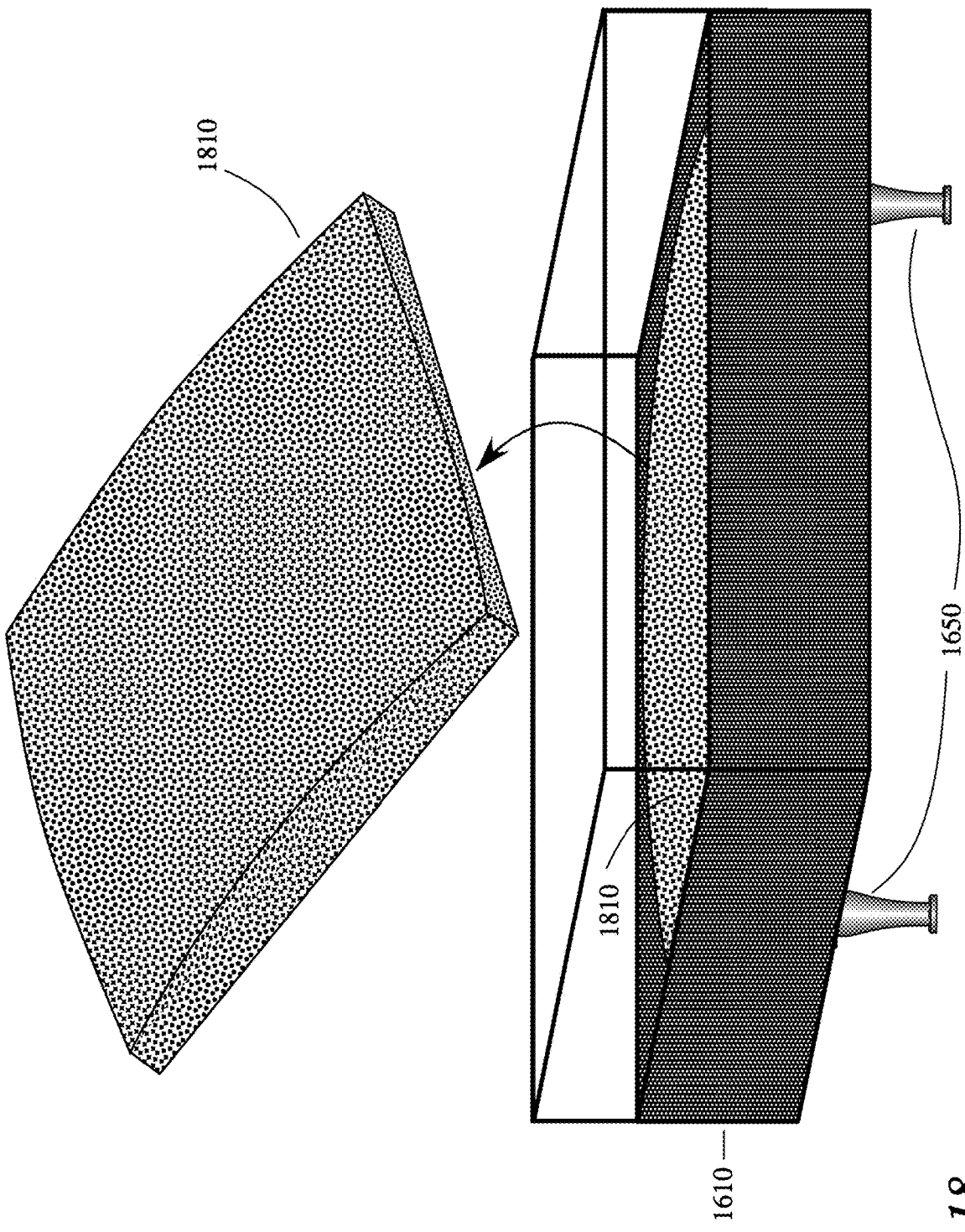

Fig 18

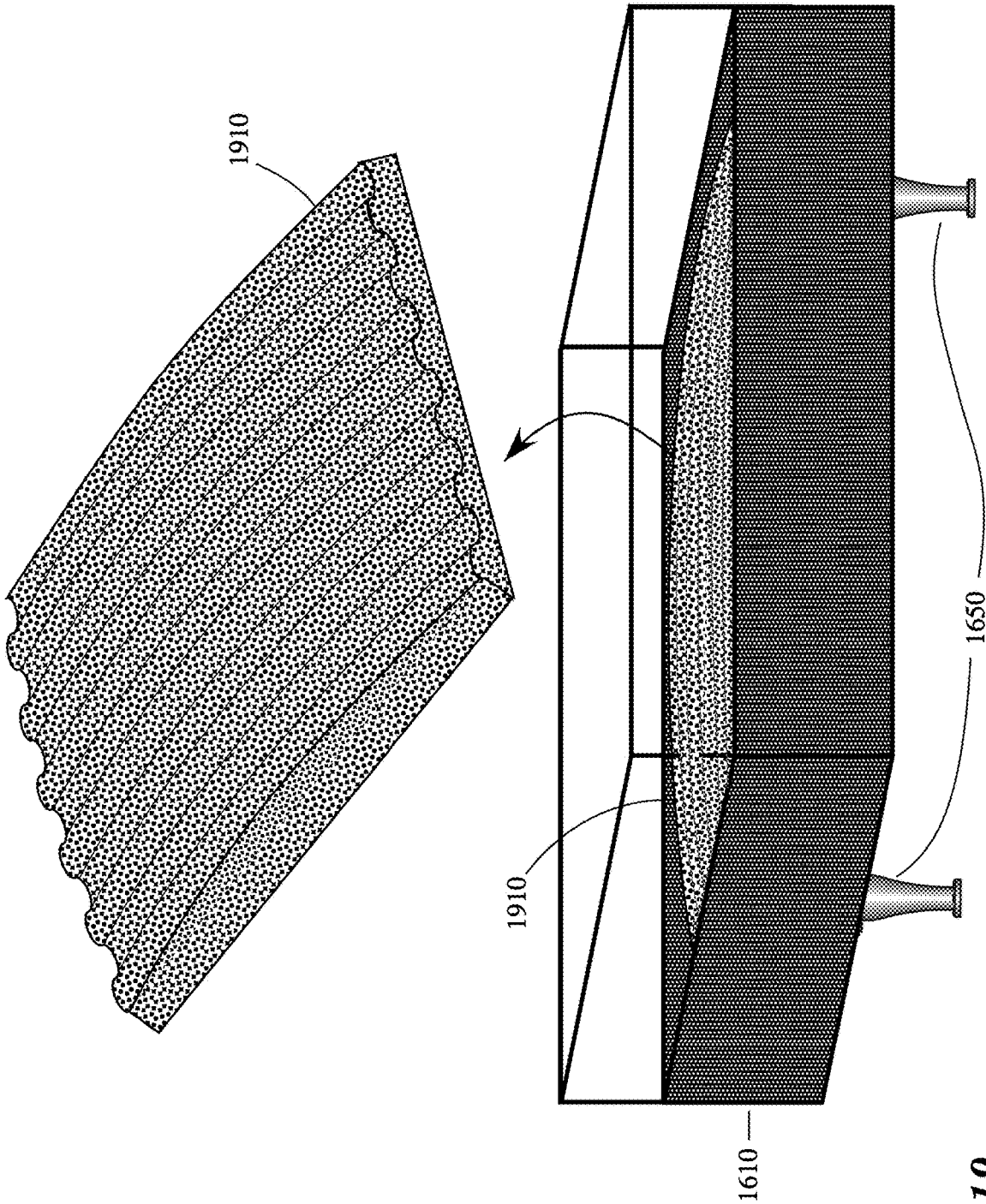
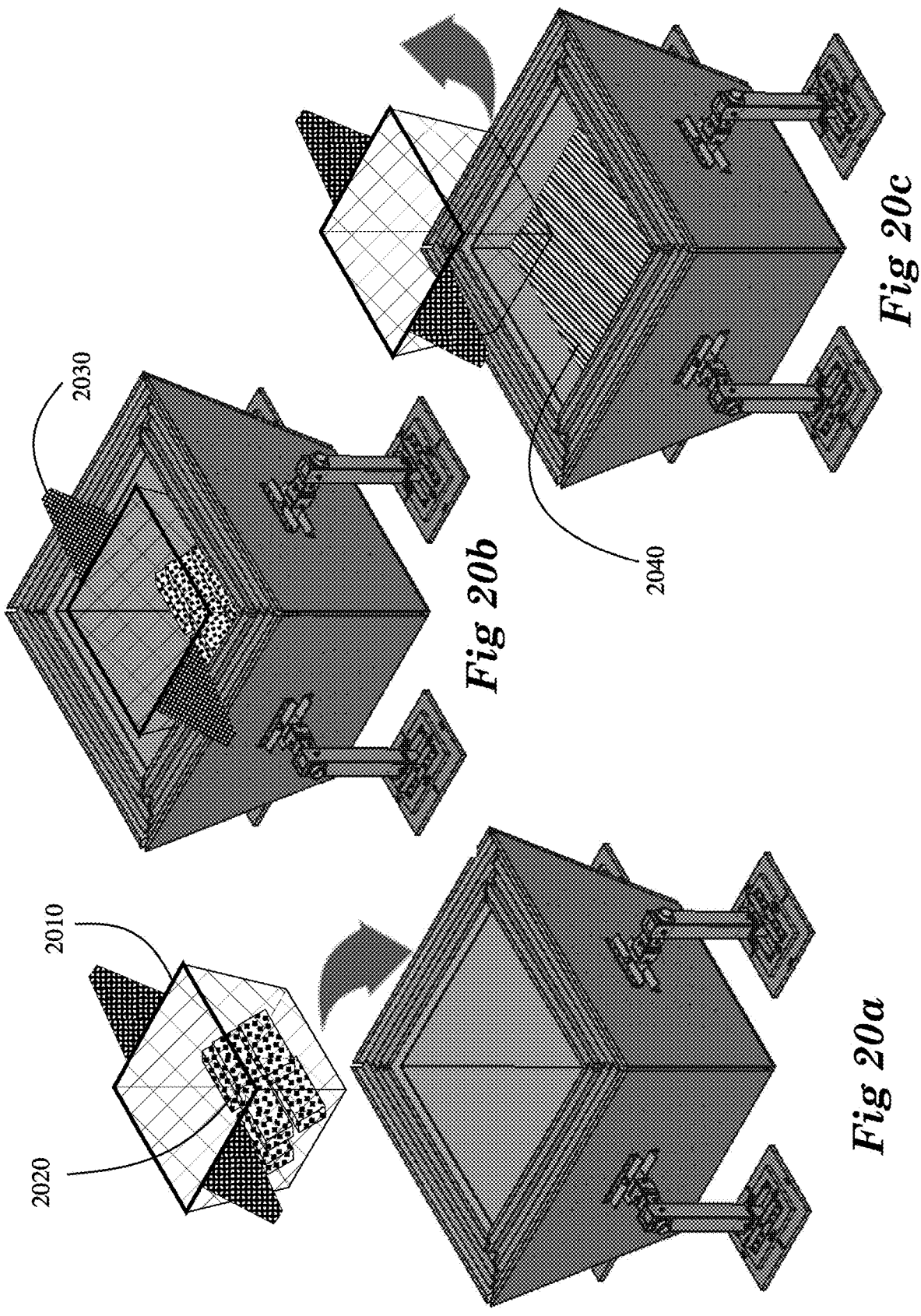

Fig 19



APPARATUS FOR FORMING SHAPED GLASS

CROSS-REFERENCE TO RELATED APPLICATIONS

[0001] This application is a continuation of U.S. patent application Ser. No. 17/942,096 filed Sep. 9, 2022, now U.S. Pat. No. 11,851,357 issued Dec. 26, 2023, which is a continuation in part of U.S. patent application Ser. No. 17/866,422, filed Jul. 15, 2022, now U.S. Pat. No. 11,821,689 issued Nov. 21, 2023, which is a continuation in part of U.S. patent application Ser. No. 17/525,818 filed Nov. 12, 2021, now U.S. Pat. No. 11,390,552 issued Jul. 19, 2022. This application claims benefit of Provisional Application No. 63/242,186 filed Sep. 9, 2021, and Provisional Application No. 63/242,350, filed Sep. 9, 2021, the contents of which are incorporated herein.

BACKGROUND

[0002] Industrial heating processes, such as processes for melting glass and metals, are largely unchanged from the way they were practiced in the last century. Sheet glass is still produced using a lehr, which is heated to its operating temperature by burning natural gas. The operating temperature is maintained for years at a time, even when glass is not being actively produced. Most of the heat in a lehr is transferred to the glass by the internal atmosphere by conduction, and the amount of atmosphere in the lehr is substantial to accommodate conveyance equipment. Air is a poor conductor.

[0003] Processes used to melt metal for applications such as aluminum casting are typically continuously operated since it takes a considerable amount of time to reach and stabilize operating temperature. The inefficiencies associated with this constraint make it impractical to melt materials with relatively high melting points in small batches, and add substantial cost and greenhouse gas emissions.

[0004] Near the middle of the twentieth century, a process was developed to make glass nearly perfectly flat by pouring the liquid glass on liquid tin. Liquids at rest near the surface of the earth take on the surface curvature of the earth, as can be recognized by the distance to the horizon on the ocean or large lakes. Because tin is denser than glass, the glass floats on the tin and spreads out to be nearly perfectly flat, with the top of the glass and the bottom of the glass nearly perfectly parallel. For a float line, a glass furnace is typically on the order of ~150 ft long by 30 ft wide and holds around 1200 tons of glass. To achieve chemical homogeneity, the glass is heated to about 1550-1600° C. in the furnace, and brought to about 1100-1200° C. in a forehearth. From there, the glass flows through a channel onto a tin bath that is maintained at a temperature of 600° C.

[0005] Because tin remains liquid at temperatures at which glass has become a solid, the glass is allowed to cool on top of the tin as a production process. To speed production, the glass is pulled along the top of the liquid tin as a continuous process by rollers at a continuous speed. As new glass is poured on the beginning of the float line, the amount of which is controlled by a tweel, cooler glass is pulled off the end of the tin pool.

[0006] This pulling process creates significant stress on the glass, causing strain deformation within the glass. The glass must go through a significant annealing process in

order to relieve the strain which, if not removed, affects the optical clarity of the glass and renders the glass fragile and subject to damage under moderate temperature and mechanical forces.

[0007] The tin bath is traditionally constructed as a cementitious refractory tank heated using combustion of petrochemical fuels (or rarely electric heating) with the heat source situated above the tin bath. This renders the process very inefficient. Additionally, since most glass is made using heat generated by combustion of petrochemical fuels, a significant amount of CO₂ is emitted.

BRIEF SUMMARY

[0008] The present disclosure describes an apparatus and method for heating materials using infrared energy.

[0009] A method of forming a sheet of shaped glass includes providing a predetermined volume of tin to a tub in a tank with a lower surface having a three-dimensional shape, activating a first plurality of infrared emitters to heat the tin to a molten state, introducing molten glass onto the molten tin; cooling the molten glass to form a solid sheet, removing the molten tin from the tank so that the solid sheet of glass contacts the lower surface of the tank, and removing the sheet of glass from the tub. The method may further include placing a top cover over the tub, wherein the top cover includes the first plurality of infrared emitters. A gas may be introduced into a space between the top cover and the glass, and the gas may pressurize the space between the top cover and the glass and presses the solid sheet of glass against the lower surface of the tank.

[0010] In an embodiment, the lower surface of the tank is a removable mold having the three-dimensional shape. The heated tin may be removed through at least one nozzle coupled to an opening in the lower surface of the tank. A vacuum may be applied through the at least one nozzle to pull the solid sheet of glass against the lower surface of the tank.

[0011] The method may further include cooling the solid sheet of glass at a rate sufficient to anneal the glass. The solid sheet of glass may be cooled at a rate sufficient to temper the glass. The glass may be cooled by providing a gas to at least one of a side assembly, a bottom assembly, and a top cover of the tank.

[0012] In an embodiment, cooling the molten glass includes providing a heat exchange fluid to a fluid channel disposed in at least one of a side assembly, a bottom assembly, and a top cover of the tank. The tin may be heated to a temperature of at least 600° C., or a temperature of at least 800° C. The glass may be removed from the tank by removing a top cover from the tank, lowering a suction device into contact with the sheet of glass and applying suction, and lifting the sheet of glass out of the tank.

[0013] The process may be a batch process which includes melting a predetermined amount of glass to provide the molten glass that is introduced onto the heated tin in a single batch. The three-dimensional shape may be a curve to form curved glass.

[0014] In an embodiment, a heating apparatus comprises a tank with a bottom assembly and four side assemblies. The bottom assembly may have at least one bottom radiant emitter and a bottom ceramic glass material on an inner surface of the tank, the bottom radiant emitter being configured to deliver infrared energy to the bottom ceramic glass material. The four side assemblies may each have at

least one side radiant emitter and a side ceramic glass material on an inner surface of the tank, the side radiant emitters being configured to deliver infrared energy to the respective side ceramic glass materials. In an embodiment, the tank includes additional side assemblies such as a fifth or sixth side assembly.

[0015] The heating apparatus may have an operating temperature of at least 600° C., or at least 950° C. The bottom ceramic glass material and the side ceramic glass material may transmit at least 30% of energy in a first frequency of the infrared spectrum. The bottom ceramic glass material and the side ceramic glass material transmit from 20 to 80% of infrared energy across a wavelength band of at least 500 nm. The wavelength band may lie between 1000 nm and 4500 nm.

[0016] In an embodiment, the bottom ceramic glass material and the side ceramic glass material transmit from 20 to 80% of infrared energy across a wavelength band of at least 1000 nm, and an upper limit of the wavelength band is below 5000 nm. The bottom ceramic glass material and the side ceramic glass material may transmit from 30 to 70% of infrared energy across a wavelength band of at least 500 nm, and an upper limit of the wavelength band may be below 5000 nm.

[0017] The heating apparatus may have a top cover assembly, the top cover assembly including at least one top radiant emitter configured to deliver infrared energy into the tank. The top cover assembly may be configured to deliver at least 90% of infrared energy across wavelengths from 1000 to 4000 nm to media disposed within the tank.

[0018] In an embodiment, the ceramic glass material of the bottom assembly includes grooves fitted to corresponding protrusions of the ceramic glass material of the four side assemblies. Inner surfaces of the four sides of the tank may have a trapezoidal shape. The tank may be mounted on a base, and the four sides of the tank are coupled to the base by adjustable mechanical assemblies. The heating apparatus may include a sealed environmental chamber enclosing the tank.

[0019] The present disclosure describes an apparatus and method for producing float glass by floating molten glass on liquid tin. The apparatus and method presented here significantly improve the efficiency of heating the tin and reduce the stress on glass as it is being processed, because a ribbon of glass is not pulled over the tin bath. The reduced stress may minimize or eliminate a process for annealing the glass. In addition, the apparatus provides a method to shape the cooling glass during the same process, allowing a single-step process for producing a curved or shaped glass product.

[0020] In an embodiment, a method of forming a sheet of float glass includes providing a predetermined volume of tin to a tub in a tank, the tub comprising a material with a transmissivity of at least 30% in a first frequency of the infrared spectrum, activating a first plurality of infrared emitters to transmit infrared energy in the first frequency to heat the tin to a temperature above 600° C., introducing molten glass onto an exposed surface of the heated tin, cooling the molten glass to a solid state, and removing the solid glass sheet from the tub. The molten tin may be removed from the tub while the glass is held at the working point (or above its softening point) so that the shape of the glass conforms to one or more contour in the base of the tub that was submerged in molten tin prior to its removal. The shape of the glass may conform to the shape of the base of

the tub or mold by the force of gravity, and a negative pressure may be applied under the glass to support the molding process.

[0021] The method may include placing a top cover over the tub, the top cover comprising a second plurality of infrared emitters, and activating the second plurality of infrared heaters to provide heat to the molten glass. The top cover may be a sealed or gas-tight cover.

[0022] In an embodiment, the method includes filling an environmental chamber containing the tank with a non-oxidizing gas. The method may further include pressurizing the environmental chamber using the non-oxidizing gas to spread the molten glass over the heated tin. Pressurizing the environmental chamber may thin a puddle of the molten glass, thereby reducing the thickness of a sheet of glass. Cooling the molten glass may include at least one of providing a gas to at least one of a side assembly, a top assembly, and a top cover of the tank, or providing a heat exchange fluid to a fluid channel disposed in at least one of a side assembly, a top assembly, and a top cover of the tank.

[0023] Removing the solid sheet of glass may include removing a top cover from the tank, moving a mechanical apparatus including a suction device over the tank, lowering the suction device into contact with the sheet of glass and applying suction, and lifting the sheet of glass out of the tank. The tin may be heated to a temperature of at least 800° C., or at least 900° C. The molten glass may be cooled at a rate sufficient to anneal or temper the glass. In an embodiment, a depth of the tin is no more than six inches when the tin is at a temperature of 650° C.

[0024] A groove may be disposed in a side of the tub at a position that corresponds to a location of an edge of the molten glass after the molten glass has spread over the surface of the heated tin. The edges of the molten glass may cool to have a shape of the groove, and a depth of the groove may be less than an amount of shrinkage experienced by the solid glass sheet so that when the solid glass sheet is removed, the solid glass sheet has finished edges. The method may be a batch process. In an embodiment, the method includes melting a predetermined amount of glass to provide the molten glass that is introduced onto the heated tin in a single batch.

[0025] In an embodiment, a method of forming a sheet of float glass includes melting a predetermined volume of tin in a tub within a tank, the tub comprising a material with a transmissivity of at least 30% in a first frequency of the infrared spectrum, activating a first plurality of infrared emitters to transmit infrared energy in the first frequency to heat the tin to a temperature above 600° C., introducing molten glass onto an exposed surface of the heated tin, placing a top cover over the tub, the top cover comprising a second plurality of infrared emitters, activating the second plurality of infrared heaters to provide heat to the molten glass, and after the molten glass has spread over the exposed surface of the heated tin, cooling the molten glass to a solid state and removing the solid glass sheet from the tub. The method may include removing the tin from under the glass and allowing the glass to drape over and take the shape of the bottom of the tank, which may be shaped as a simple or complex curved surface. The material of the tub, which may include the shaped bottom of the tub, may have a passband corresponding to the first frequency.

[0026] The method may include filling an environmental chamber containing the tank with a non-oxidizing gas, and

pressurizing the environmental chamber using the non-oxidizing gas to spread the molten glass over the heated tin. Pressurizing the environmental chamber may cause the molten glass to spread across the surface of the heated tin, thereby reducing a thickness of the molten glass. Cooling the molten glass may include one or both of providing a gas to at least one of a side assembly, a top assembly, and a top cover of the tank, and providing a fluid to at least one of a side assembly, a top assembly, and a top cover of the tank. The molten glass may be cooled at a rate sufficient to temper the glass.

BRIEF DESCRIPTION OF THE DRAWINGS

[0027] The accompanying drawings are intended to convey concepts of the present disclosure and are not intended as blueprints for construction, as they are not necessarily drawn to scale: the drawings may be exaggerated to express aspects of unique detail. The figures merely describe example embodiments of the present disclosure, and the scope of the present disclosure should not be construed as limited to the specific embodiments described herein. The foregoing aspects and many of the attendant advantages of embodiments of this disclosure will become more readily appreciated by reference to the following detailed descriptions, when taken in conjunction with the accompanying drawings, wherein:

[0028] FIG. 1 is a front perspective view of an embodiment of a glass processing system, showing a molten tin-handling tank assembly and cover mounted on a platform, surrounded by support arms positioning insulating bricks, infrared emitters and refractory layers against a ceramic glass tub, all of which is housed within an environmental chamber.

[0029] FIG. 2 shows an elevation view of an embodiment of a tank assembly, with a tank platform, bottom mount and support arms, without a top cover equipment or environmental containment chamber.

[0030] FIG. 2 also includes an inset with a cross-sectional view to show the interior tub and refractory layers.

[0031] FIGS. 3a, 3b and 3c are various views of an embodiment of a tank bottom assembly. FIG. 3a is a top view showing the top layer of refractory and the bricks and infrared emitters mounted in it. FIG. 3b is an elevation view of the tank bottom showing the mount plate and its plurality of refractory layers on which the tub rests. FIG. 3c shows a front perspective view with the refractory layers, gas jets, heat-removing coils and emitters removed to show positioning of insulating bricks. An inset shows detail of an insulating brick pair with sheet metal wrap, conceptually removed from its mounting plate.

[0032] FIGS. 4a and 4b show various views of an embodiment of a tank side assembly. FIG. 4a is a front elevation view, showing the attachment of a support arm subassembly to the side of the tank. FIG. 4b is a side elevation view showing a plurality of refractory layers which will be pressed up against the side of the tub resisting the gravitational forces against the tin.

[0033] FIGS. 5a and 5b are two more views of an embodiment of a side of the tank. FIG. 5a is a cut-away view showing components of the tank side including insulating bricks and emitters. FIG. 5b shows a side perspective view of the side without refractory layers, infrared emitters, cooling jets and heat-removing coils to show the positioning of the insulating bricks.

[0034] FIGS. 6a, 6b and 6c are various views of an embodiment of a side support assembly that supports a side of the tank. FIG. 6a is a back view, FIG. 6b is a side view, and FIG. 6c is a view of the face of the arm which attaches to the mount plate of the tin tank side support assembly.

[0035] FIGS. 7a, 7b and 7c are various views of an embodiment of a mount foot of the side support assembly. FIG. 7a is a front elevation view of the mount foot, showing various adjustment components for raising or lowering the side support. FIG. 7b is a top perspective view of the mount foot. FIG. 7c is a top view of the mount foot, showing various attachment components and a pivoting axle.

[0036] FIGS. 8a, 8b and 8c are various views of an embodiment of a ceramic glass tub. FIG. 8a is a top perspective view of the tub. FIG. 8b is a top view straight down into the mouth of the tank with insets which show an edge mold cut into the sides of the tub to receive the edge of the liquid glass. FIG. 8c is an elevation view of the tub, with insets showing the interface between two sheets of ceramic glass forming a lower corner of the tub.

[0037] FIGS. 9a, 9b and 9c show various views of an embodiment of a load cell foot. FIG. 9a is a front elevation view. FIG. 9b shows a side elevation view, including an inset with a magnified view showing a load cell and load cell attachment. FIG. 9c shows a top perspective view of the platform support foot.

[0038] FIG. 10 is a front perspective view of an embodiment of a top cover showing a general orientation of some components. The inset shows a cross-sectional elevation view indicating the relationship of refractory layers, ceramic glass plate, emitters and temperature sensor in the embodiment.

[0039] FIGS. 11a, 11b and 11c show an embodiment of a process of pouring liquid glass into a tank. FIG. 11a shows a top perspective view of the tank as the glass is being poured in. FIG. 11b shows the glass spreading out and thinning as it pours. FIG. 11c shows the glass as it reaches its equilibrium thickness.

[0040] FIG. 12 shows a graph of viscosity of amorphous silicates and significant physiological points in glass manufacturing. Of note is the viscosity difference of the glass between 600° C. and 950° C.

[0041] FIG. 13 is a transmission vs. wavelength plot for non-tinted second-generation ceramic glasses plotted along with various tuning plots for an infrared emitter.

[0042] FIG. 14 is a transmission vs. wavelength plot for opaque second-generation ceramic glasses plotted along with various tuning plots for an infrared emitter.

[0043] FIG. 15 is a flow chart showing an embodiment of a process of producing float glass.

[0044] FIG. 16 shows a front perspective view of an embodiment of a tank with a layer of melted tin on which molten glass is being poured for cooling and shaping. The top part of the tank is made transparent in this figure, and those following, to provide a view of the tin bath within the tank. The nozzles below the tin allow the tin to be drained out after the glass has cooled enough to become viscous yet still movable by gravity and/or gas pressure.

[0045] FIG. 16 includes an inset showing an elevation view, conceptually made transparent, showing the disposition of the tin around the mold inside the tub.

[0046] FIG. 17 is an embodiment of the tank in FIG. 16 with the melted tin drained to show a curved mold to form

a radius of curvature. The inset shows the curved mold with a complex concave curve in two axes.

[0047] FIG. 18 is an embodiment of the tank in FIG. 16 with the melted tin drained to show a curved mold to form a radius of curvature. The inset shows the curved mold with a complex convex curve in two axes.

[0048] FIG. 19 is an embodiment of the tank in FIG. 16 with the melted tin drained to show a complex mold to form a series of ripples. The inset shows the mold with a sinusoidal curved surface.

[0049] FIGS. 20a, 20b and 20c show an embodiment of a heating process using a basket to lower media into a tank.

FIG. 20a shows a top perspective view of the tank without a top cover as the basket is ready to lower into the tank. FIG. 20b shows the basket in place inside the tank, and FIG. 20c shows an empty basket being removed from the tank after the media has been melted.

DETAILED DESCRIPTION

[0050] The following list provides specific descriptions and examples of items that are present in the embodiments illustrated by the figures. The descriptions in the list are illustrative of specific embodiments, and should not be construed as limiting the scope of this disclosure.

Numerals	Description
100	Float glass system
102	Tank
104	Controller
110	Tank platform
120	Tank side assembly
130	Tank bottom assembly
140	Tank platform load cell foot
150	Tank roof or top cover assembly
160	Environmental chamber
210	Tub
220	Forklift pocket
310	Bottom plate
315	Shallow placement pocket in bottom plate
320	Bottom refractory layer
321	Cooling gas jet in tank bottom assembly
322	Fluid channel in tank bottom assembly
330	Innermost bottom refractory layer
340	Insulating brick
345	Sheet metal wrap forming hollow pocket to hold insulating brick
346	Sheet metal band or retainer
350	Hole in refractory for brick mounting in bottom assembly
360	Infrared radiant emitter in bottom assembly
370	Hole in refractory for infrared radiant emitter in bottom assembly
410	Side plate
420	Side refractory layer
430	Innermost side refractory layer
540	Insulating brick in tank side assembly
550	Hole in refractory for brick mounting in tank side assembly
560	Infrared radiant emitter in tank side assembly
570	Hole in refractory for emitter mounting in tank side assembly
580	Cooling gas jets in tank side assembly
590	Fluid channel in tank side assembly
600	Side Support assembly
610	Side Support heat brace
620	Side Support post
630	Side Support rotator collar
640	Side Support articulator
650	Side Support mount pivot
660	Side Support heat brace mount
670	Mounting bolt and pivot axle
700	Side support base
710	Support mount providing north-south adaptability
720	Support base providing east-west adaptability
730	Tank leg brace
740	Tank support foot
750	Height adjust shaft
760	Height adjust nut
770	Slotted mounting holes
780	Tank Support Collar
810	Ceramic glass side plate
820	Ceramic glass bottom plate
825	Groove in sides of tub walls
830	Protrusion ground into edge, comprising curves which minimize stress on the glass
831	First side radius of curvature of protrusion 830
832	Second side radius of curvature of protrusion 830
840	Groove ground near edge functioning as a receiver for protrusion 830
841	First side radius of curvature of groove 840
843	Second side radius of curvature of groove 840

-continued

Numeral	Description
850	Matching radius of curvature between protrusion 830 and groove 840, the load-bearing and sealing element of the ceramic glass-constructed tank assembly
860	Ceramic adhesive sealant at joints between sheets of ceramic glass
910	Heat brace
920	Connecting support/pivot
930	Load support
940	Load cell housing
950	Load cell
960	Height adjustment shaft
970	Height adjustment nut
980	Ankle attachment/pivot
990	Mounting plate
1010	Tunable high intensity infrared emitter
1020	Optical two-wavelength emissivity compensating temperature sensor
1030	Machined very low thermal conductivity ceramic fiber refractory
1040	Radio frequency proximity sensor configured to measure range to the tin pool
1050	Ceramic glass tank cover plate
1055	Metal lip on bottom of tank cover assembly
1060	Non-oxidizing cooling gas jet in tank cover assembly
1070	Fluid channel in tank cover assembly
1080	Thermocouple temperature sensor
1090	Mounting plate for tank cover
1110	Tin pool surface
1120	Liquid glass being poured into tin tank
1130	Glass spreading out on tin bath
1140	Glass as it reaches equilibrium thickness at the edge of the tub
1210	Viscosity vs temperature curve for soda-lime glass
1220	Conventional tin pool temperature of 600° C. indicating a log viscosity of about 9
1230	Tin pool temperature for receiving glass with a viscosity log of about 4.2
1240	Tin pool temperature for receiving glass with a viscosity log of about 5.8
1310	Identifies the upper and highly transmissive passband for an example second generation non-tinted translucent ceramic glass at a selected wavelength
1320	Output curve for infrared heater tuned to peak of about 3250 nm
1325	Peak of output curve at about 3250 nm
1410	Output curve for infrared heater tuned to peak of about 1500 nm
1415	Peak of output curve at about 1500 nm
1420	Output curve for infrared heater tuned to peak of about 3250 nm
1425	Peak of output curve at about 3250 nm
1430	Output curve for infrared heater tuned to peak of about 2250 nm
1435	Peak of output curve at about 2250 nm
1610	Tank of a glass molding apparatus
1620	Tin pool within tub
1630	Molten glass being poured into molding tub
1650	Nozzle at bottom of molding tub to drain melted tin
1710	Molten glass mold for making complex curved glass, concave in two axes
1810	Molten glass mold for making complex curved glass, convex in two axes
1910	Molten glass mold for making complex curved glass, with series of sinusoidal curves
2010	Basket
2020	Media to be heated
2030	Handles on basket 2010 for managing movement and resting on edge of tank
2040	Melted media

[0051] Embodiments of the present disclosure include a system that heats tin or other materials by exposure to high-intensity infrared energy from the sides and the bottom of a tank through ceramic glass that is highly transmissive at certain infrared wavelengths. This physical construction enables a high level of control and responsiveness in temperature management.

[0052] The ceramic glass material may have one or more passband in which portions of certain infrared frequencies are passed through the glass at relatively high transmittance, while other frequencies outside the passbands have lower transmittance. The use of ceramic glass with passbands allows infrared energy to partially penetrate the ceramic glass material while also being partially absorbed by the material, resulting in an efficient thermal transfer along the depth of a sheet of ceramic glass. In contrast, conventional

ceramic materials tend to reflect most infrared energy, while glass materials tend to pass infrared energy.

[0053] Some embodiments of the present disclosure are directed to a process and apparatus for producing sheets of glass using a tin bath. A tin bath can be heated to temperatures such as 950° C. where the viscosity of the glass is reduced by more than four orders of magnitude over conventional processes where the tin is kept at approximately 600° C. Because tin has a thermal conductivity that is an order of magnitude higher than glass, the tin can be used to control the glass temperature by heating or cooling the tin externally.

[0054] The embodiment of a tin bath illustrated by the figures comprises a tub **210** in which at least a bottom surface is ceramic glass, surrounded on each of four sides by tank side support assemblies **120**, and supported from below by a bottom assembly **130**. These tank side support assem-

blies and bottom assembly contain insulating bricks **340**, **540** mounted on an aluminum plate **310**, **410** to support the ceramic glass plates **810**, **820** comprising the tub and minimize the load stresses applied to the ceramic glass. The insulating bricks may have a compression strength that is an order of magnitude higher than a ceramic fiber insulating refractory material that fills voids between the working components of the containment system.

[0055] The plate **410** of the tank side support assembly is supported by a 6-degree of freedom alignment mechanism (side support arm assembly **600**) that supports a precise fit between the ceramic glass tank components. This fit is aided by the sort of ball and socket or rod and trough edge treatment of the ceramic glass in the embodiment shown in FIG. **8C**. Additionally, the entire tank assembly of tub **210**, tank side support assemblies **120**, and bottom assembly **130** is mounted on a tank platform and support **110** which includes platform load cell feet **140** which incorporate a series of load cells **950** enabling the measurement and precise delivery of glass to the float process. This minimizes down-stream processing and product waste recycling where appropriately sized tin baths can produce near-finished products.

[0056] This high level of control enables a return to the batch processes of previous generations of plate glass manufacturing but with an improved float glass product. Such a process enables highly efficient short startup and cool down times, as well as precise production on demand.

[0057] In a traditional float glass process, the tin bath has a significant volume to assist in stabilizing the temperature of the bath which is heated from above. The goal of the traditional float glass control process is to keep the tin bath at the same temperature all the time. For this reason, float glass production lines run 24x7 for years until the line is replaced by new equipment.

[0058] Traditional float glass processes mechanically pull the cooling glass along the tin bath. This pulling introduces significant stresses into the glass. The edges of the glass where the tractor cleats interface with the glass create strain deformation which is routinely cut off and recycled as part of the ongoing production process, thus reducing overall efficiency. The glass is typically at a temperature that is greater than 1,200° C. when it is poured onto the tin bath. The 600° C. temperature of the tin bath also causes significant stress on the glass since the glass surface in contact with the tin, or lower side, cools more quickly than the exposed upper side of the glass.

[0059] The strain deformation within the float glass product is relieved by the next step in a conventional production process line, called a Lehr oven. Lehrs can be up to and greater than 1,000 feet in length. They are usually gas fired and are used to anneal the glass by elevating the glass up to near 800° C. for an extended period of time, after which the glass is allowed to slowly cool. The product from the Lehr process is annealed float glass.

[0060] In contrast, an embodiment of the present disclosure operates with a minimal tin bath volume. Molten tin is typically several times the density of molten glass, so it is possible to float a layer of glass on a layer of tin that is thinner than the floated glass. Accordingly, in some embodiments, the layer of molten tin on which the glass is floated may be 0.1 mm, 1 mm, 1 cm, 2 cm, 3 cm, 5 cm, or greater.

[0061] Embodiments are suitable for producing window glass, which is typically about 6.3 mm thick, and for

producing interior cores of electrochromic glass, which may have a thickness below 5 mm, 1 mm, or 0.5 mm, for example. While greater thicknesses of tin provide a larger thermal mass that may reduce fluctuations in temperature, lower thicknesses of tin can be heated and cooled more quickly, and require less energy to heat.

[0062] In an embodiment, infrared energy can be provided fast enough that the tin can be heated to as much as 950° C. or more to minimize the thermal shock of the glass being poured onto the surface of the tin. Significantly, the stresses introduced are much less than would exist if the tin were at a lower temperature, such as the 600° C. temperature of conventional processes. Additionally, because the stresses introduced by the thermal shock are smaller, they are more quickly relieved from the glass because the viscosity of the glass is more than four orders of magnitude lower at 950° C. than it is at 600° C., and more than 2 orders of magnitude smaller at 800° C. Accordingly, a process of the present disclosure may heat the tin to a temperature that is greater than 600° C. or 950° C. Finally, because the glass is not pulled along the surface of the tin and the temperature of the tin is much higher than the traditional float glass process, an annealing time may be reduced to seconds or minutes instead of hours.

[0063] In a process of the present disclosure, the tin may be both heated and cooled to control its temperature, and thereby control the temperature of the bottom surface of glass floating on the molten tin. Simultaneously, the top of the glass may be heated or cooled to maintain a desired temperature. The temperature of the upper surface of the glass may be controlled to be close to the temperature of the tin and the bottom of the float glass—for example, the temperature of the upper surface of the glass may be controlled to be within 10° C., 50° C. or 100° C. of the temperature of the tin. Temperature sensors **1020** and **1080** may be employed to measure the temperature of the upper surface of the glass. In an embodiment, temperature sensor **1080** is configured to measure the temperature of ceramic glass sheet **1050** or refractory layers **1030**, and temperature sensor **1020** is configured to measure the temperature of material in the tank.

[0064] The temperature of the tin may be monitored simultaneously with the temperature of the ceramic glass containing the tin bath. The apparatus heating the tin using the incorporated tunable infrared emitter **360**, **560** which can pass infrared thermal energy through the ceramic glass **810**, **820** also employs non-oxidizing gas jets **321**, **580** and conduction fluid heat exchangers **322**, **590** on the surface of the ceramic glass to cool the tin **1110** by cooling the ceramic glass. The ceramic glass is in contact with the tin which is cooled by conduction. Accordingly, an embodiment of a float glass system **100** may control an amount of energy provided to infrared emitters **360**, **560**, a frequency of infrared energy emitted by emitters, a supply and temperature of gas provided by gas jets **321**, **580**, and an amount and temperature of fluid flowing through fluid heat exchangers **322**, **590** to precisely control the temperature of molten tin and a temperature of a bottom surface of glass floating on the layer of molten tin.

[0065] The top of the product glass undergoing the annealing/cooling process may be temperature controlled using a similar mechanism. The tank cover **150** may also incorporate tunable infrared emitters **1010**, non-oxidizing gas cooling jets **1060** and a conduction fluid heat exchanger **1070**.

The position of the tank cover **150** may be determined using radio frequency proximity sensors **1040** to enable the positioning of the top ceramic glass **1050** at a precision that is within as little as fractions of a millimeter to provide effective non-contact heating and cooling of the surface of the glass being formed. The volume between the upper surface of floating glass and the lower surface of the tank cover **150** may be controlled so to minimize space between the tank cover and the glass, which increases the efficiency of the system, while providing sufficient volume to circulate gas to control the temperature of the upper surface of the glass. Therefore, the space between the molten glass in the tank and elements of the tank cover disposed over the glass may be less than 1 cm, less than 2 cm, less than 5 cm, or less than 10 cm, for example. In an embodiment, no ceramic glass layer is present in the tank cover **150**, and cooling jets can blow directly onto a surface of the glass layer. In another embodiment, holes are present in a ceramic glass layer so that the cooling jets can blow a cooling gas directly onto the float glass.

[0066] In an embodiment, the entire forming apparatus is enclosed in an environmental chamber **160** to enable the management of a pressurized, non-oxidizing atmosphere which keeps the tin from oxidizing and the glass surfaces clean. The gas used for the atmosphere may be, for example, a forming gas, a reducing gas in general with some amount of hydrogen, or an inert gas such as argon or nitrogen, or a blend of inert gasses. The system may include a controller that is configured to control the pressurized bath from a low of less than 1 Torr to a maximum of more than 5,000 Torr. The ability to control the pressure on the tin bath enables the manipulation of the equalization of the forces acting on the glass to arrive at an “equalization thickness” and thus, along with the control of the size of the tin bath, the temperature of the tin bath and the temperature of the glass, the thickness of a sheet of glass produced by the forming apparatus can be controlled to be from a millimeter to tens of centimeters. See, e.g., processes **S1510**, **S1515**, **S1520** in FIG. 15, where the type of glass being created is input to the system so that the process can be configured to produce and treat the glass according to the input parameters.

[0067] When the glass under process is cooled to a temperature of approximately 250° C., per the cooling profile accessed in **S1561**, it is a nearly finished glass product. The product glass can be lifted from the tin bath **1110** using silicon suction cup devices to lift the glass from the surface of the tin. This product can be scored and cut to a finished size and provided as an annealed glass.

[0068] Alternatively, if the rate of controlled cooling is accelerated, a finished tempered glass sheet is produced and can similarly be lifted off of the liquid tin or a shaped mold that was in position under the liquid tin, as a finished product.

[0069] Individually and in combination, the technologies revealed in this disclosure may reduce the process times to make a finished float glass or a finished tempered glass product from hours to minutes and reduce the energy requirement for either process by orders of magnitude.

[0070] Embodiments of the present disclosure will now be described with respect to the features illustrated by the figures. Referring to FIGS. 1 and 2, an embodiment of a float glass system **100** includes a tank **102** that is configured to retain and heat molten tin and glass in a float glass process. The tank **102** includes four side support assemblies **120** and

a tank cover **150** that encloses the tank. The tank **102** is supported by a platform **110** that supports the weight of the tank. As seen in FIG. 2, the platform **110** may include forklift pockets **220** for ease of portability. The platform may have tracks, guides, or similar structures other than forklift pockets **220** that can facilitate transportation of the tank **102**. In another embodiment, the tank **102** may be stationary and permanently mounted to a floor or base.

[0071] FIG. 2 shows a set of load cell feet **140** disposed under the lower surface of the platform **110**. The load cell feet **140** are mechanical assemblies that incorporate load cells **950**, which measure the mass of materials that are placed in the tank **102**. In particular, the load cells **950** may be used to measure an amount of tin and an amount of glass that is introduced into the tank **102** in a float glass manufacturing process. In an embodiment, values from the load cells are provided to a controller **104** to accurately control the amount of glass that is introduced into the tank **102**, and to confirm that the tank contains a desired amount of tin, glass, or both.

[0072] The tank **102** further comprises a bottom assembly **130**. Together, the bottom assembly **130** and side support assemblies **120** support bottom and side surfaces of a tub **210** that is in turn configured to support molten tin and molten glass that is poured onto the molten tin. Accordingly, the tub **210** is a vessel for creating float glass. Although the tub **210** illustrated by the present figures uses separate pieces of material for the sides and bottom of the tub, in another embodiment, the tub may be formed of a single piece of material. For example, the tub **210** may comprise a single piece of ceramic material that is cast, sintered, or machined to have a net shape of a tub which may include curved surfaces that serve as a mold.

[0073] FIGS. 3a, 3b and 3c illustrate an embodiment of a bottom assembly **130**. The assembly includes a bottom plate **310** which is an exterior surface of the tank **102**, and may be a metal material such as aluminum or steel. As seen in FIGS. 3a and 3c, a plurality of insulating bricks **340** may be mounted directly to the plate **310**, and infrared emitters **360** are disposed in spaces between the bricks **340**. One or more layer of refractory material **320** is stacked on the bottom plate **310**, and the refractory layers **320**, **330** are perforated with holes **350** that have the same shape as the bricks **340**. In this way, the bricks **340** maintain the refractory layers **320** in a desired orientation while a majority of the volume between the bottom of the tub **210** and the bottom plate **310** is occupied by refractory material.

[0074] In an embodiment, a sheet metal wrap structure **345** is formed and placed over a set of refractory insulating bricks **340** already situated within a shallow placement pocket **315** in the bottom plate **310**. The sheet metal wrap structure **345** is mechanically secured to the plate **310** and a metal band or similar retaining mechanism **346** is placed around the wrap structure and the two pieces of insulating bricks. In this way, a plurality of insulating bricks **340** can be mechanically coupled to bottom plate **310** in a fixed orientation. Although the bricks **340** are illustrated as having square cross-sectional shapes, other shapes are possible, such as rectangular or circular. In other embodiments, the bricks **340** may be fixed to the plate **310** in a different way from the mechanical assembly described above. In addition, in some embodiments, the bricks **340** comprise a single piece of refractory material or more than two pieces of refractory material.

[0075] As illustrated in FIG. 3*b*, a set of refractory layers 320 are stacked on the bottom plate 310. In an embodiment, the refractory layers may be ceramic refractory board materials of standard thickness, e.g. ½, 1, or 2 inches thick. Edges of the refractory layers 320 may be beveled at an angle that matches the angle at which sides of the tank 102 are oriented so that refractory layers 320 of the base fit snugly against front faces of refractory layers 420 of side support assemblies 120. The interfaces may be sealed with a ceramic paste material in a final assembly.

[0076] One or more of refractory layer 320, 330 may include a fluid channel 322 that transports a heat-exchange fluid. The fluid channel 322 may include temperature resistant tubing and be thermally coupled to a ceramic glass layer that forms the bottom surface 820 of the tub 210. In an embodiment, the refractory layer 330 that contacts the bottom of tub 210 is a 1-inch-thick layer of material, and the fluid channel 322 is disposed in that layer. In a different embodiment the fluid channel 322 is spaced apart from the bottom surface 820 of tub 210 to reduce the temperature to which the fluid channel is exposed.

[0077] A plurality of infrared emitters 360 are disposed in pockets 370 in one of the refractory layers. The emitters may be placed as close as is practical to the bottom surface 820 of the tub 210, and depending on the height of the emitters 360, the emitters may penetrate one, two or more of the refractory layers 320 and 330. Wiring for the infrared emitters 360 may be disposed in holes that are provided in the refractory layers 320. In another embodiment, wiring for the emitters 360 is routed through the bricks 340.

[0078] In an embodiment, one or more cooling jet 321 is disposed in the bottom support assembly 130. The cooling jet 321 may be configured to provide a jet of cooling gas to the bottom support assembly 130. In an embodiment, the cooling jets 321 have both a supply and a return orifice to supply cool gas and receive hot gas, thereby displacing heat from the bottom support assembly 130. Although FIG. 3*a* shows the cooling jets 321 as located in the same general area as the emitters 360, embodiments are not restricted to that location. In addition, vent channels may be provided in one or more of the refractory layers 320 to provide a return path to receive heated gas displaced by cooler gas from the cooling jets 321.

[0079] Although FIG. 2 shows tub 210 as being relatively deep compared to its width, the relative depth of embodiments may be much shallower. Energy efficiency of the system can be increased by minimizing the amount of space between the upper surface of a layer of floating molten glass and the lowest surface of the tank cover 150, and by minimizing the amount of tin in the tub 210. Accordingly, the tub 210 may have a depth of from less than one tenth of an inch to one inch to several inches, or several tens of centimeters, for example. The width of the tub 210 may be sized to create a desired size of glass sheet, which may be several feet in both dimensions. Edges of a sheet of float glass may be scored and removed after being formed, so the tub 210 may have a width and length that are larger than the size of a final glass product. In some examples, the width and length are from one foot to ten or twenty feet or more.

[0080] FIGS. 4*a* and 4*b* illustrate an embodiment of a tank side support assembly 120. Interior components of the side support assembly 120 are similar to the components of the bottom assembly 130 discussed above—for example, the side support assembly includes a side plate 410 that may be

a metal material as an outer surface, a plurality of refractory layers 420 disposed over the side plate, and an innermost refractory layer 430 that is thinner than the other refractory layers 420. However, this arrangement is simply one exemplary embodiment, and other materials and thicknesses are possible.

[0081] Lower edges of the refractory layers 420 are disposed at different elevations, and are configured to interface with corresponding edges of refractory layers 320 of the bottom assembly 130. Similarly, side edges of at least some of the refractory layers 420 are inset from one another as they move inward, so that the total width of the innermost refractory layers is less than the width of the outermost layers. The location of upper edges of the refractory layers 420, 430 may be staggered to allow refractory layers 1030 and metal lip 1055 of tank cover 150 to seat into a recessed area of the refractory layers for secure fitment and to shield the metal lip from direct exposure to the infrared emitters.

[0082] The side assembly 120 includes a side support assembly 600 that holds a side of the tank 102 in place. In an embodiment, each side of a tank 102 is held in position by a side support assembly 600 that can be adjusted with multiple degrees of freedom to provide precise alignment for each side of the tank with respect to the bottom and other sides.

[0083] FIGS. 5*a* and 5*b* are front and perspective views of a tank side assembly 120. The embodiments shown in these views include a plurality of refractory brick structures 540, which may be the same or similar to the bricks 340 discussed above. The bricks 540 may be coupled to side plate 410 by an interface with a metal component that is welded or threaded into the side plate. In addition, the side assembly 120 may include a fluid channel 590, radiant emitters 560, and gas jets 580. The refractory layers may have holes 570 which accommodate and expose radiant emitters 560, and holes 550 that accommodate bricks 540.

[0084] In other embodiments, the arrangement, size and density of these structures may be different from the configuration shown in FIG. 5*a*. For example, in some embodiments, none of the components including emitters, fluid channels, bricks and gas jets are present. In such an embodiment, the refractory layers may extend uninterrupted across the width of the tank walls. In another embodiment, one or more brick or similar structure is present to retain refractory layers, but no radiant emitters, gas jets or fluid channels are present. In some embodiments, the upper and lower radiant emitters 360 and 1010 are in close proximity to the molten materials in the tank—for example, radiant emitters may be within 6, 12, 18 or 24 inches of a lower surface of the molten tin or an upper surface of molten glass.

[0085] In some embodiments the depth of the tin and glass is only a few inches or less, so only one or two rows of emitters 560 are present in a side of the tank. In another embodiment, no emitters are present, but fluid channels 590 and/or gas jets 580 are present in the sides of the tank to assist with cooling materials in the tank. Other variations are possible.

[0086] FIGS. 6*a*, 6*b* and 6*c* show three different views of a side support assembly 600. The side support assembly 600 in these figures can be adjusted with six degrees of freedom, but other embodiments may use a side support with more or less capability for adjustment than the embodiment shown here.

[0087] In the embodiment shown in FIGS. 6a-6c, the side support assembly 600 includes a side support post 620 with adjustable vertical travel, and braces 610 that couple the side support assembly 600 to sides of the tank. A rotator collar 630 may adjust horizontal position of the braces 610, and horizontal and vertical angles may be changed by adjusting the pivot 650, articulator 640 and heat brace mount 660. For example, pivot axle 670 may serve as a pivot axis for adjusting the vertical angle. In combination, the structures of support assembly 600 provide a mechanism for aligning sides of a tank 120 to interface with one another and with tank bottom assembly 130 with a high degree of precision to stably support a ceramic glass tub 210 in a float glass process.

[0088] FIGS. 7a, 7b and 7c are views of a base 700 of the side support assembly 600. The base includes two plates 710 and 720 with slots 770 that can be adjusted in respective horizontal axes, a brace 730 that supports a foot 740, and a height adjusting nut 760 between the foot 740 and collar 780 that can adjust vertical travel. The collar 780 may be coupled to support arm 620. Accordingly, the base 700 can be adjusted in several different ways to change the location of side support 600 with respect to X, Y and Z axis travel and rotate the side support.

[0089] FIGS. 8a, 8b and 8c illustrate several views of a tub 210 that is configured to retain a bath of molten tin and a layer of molten glass floating on the molten tin. The tub illustrated in these figures has trapezoidal sides 810 and a square bottom 820. In the embodiment shown in these figures, the tub 210 is constructed of five separate plates whose edges are fitted together and supported by tank side assembly 120 and side support arms 600.

[0090] FIG. 8c shows a detail of an embodiment of one possible mechanical interface between a bottom plate 820 and side plate 810. In the example shown in FIG. 8c, bottom sheet 820 has a semi-circular groove 840 that with a radius 850 transitions to first and second radii 841 and 843. The groove 840 has a radius 850 that is the same as the radius of protrusion 830, so that the protrusion has a positive fit with groove 840. The protrusion 830 of the side plate 810 transitions to a first inset radius 832, which in turn transitions to the nominal thickness of the plate by radius 831.

[0091] Accordingly, in the embodiment shown in FIG. 8c, no sharp corners are present in an interface, reducing the chance that the edges would break under thermal and physical forces. In addition, the interface of radius 850 provides a snug fit with a relatively large surface area that can be maintained even if the side plate 830 rotates, which could accommodate displacement at temperature due to thermal expansion. The interface between groove 840 in the bottom plate 820 and the protrusion 830 on side plate 810 may be enhanced by a sealing material 860 such as a ceramic adhesive material, e.g. an alumina paste or putty to seal the joint.

[0092] The tub 210 may further include a groove 825 in the side plates 810. The groove 825 may be disposed at a height corresponding to an elevation of a floating glass layer, so that edges of the float glass terminate at the groove 825. The groove 825 may be a curved groove so that edges of the glass are curved, which could reduce or eliminate the need for finishing edges of a sheet of float glass, and reduce the amount of stress that is captured at the edges of the sheet of glass. The reduction in stress at the edges of a sheet of glass

may be especially helpful when the cooling process is controlled to temper a sheet of product glass.

[0093] The second arrow in FIG. 8b points to a profile of the shape of an embodiment of a groove 825. Float glass may have a higher coefficient of thermal expansion (CTE) than other materials of the tank, so edges of the glass may withdraw from contact with the side plates 810 as the glass cools. Accordingly, it is possible to provide an undercut in the groove 825 that would not prevent a sheet of float glass from releasing from the tub 210. The shape of groove 825 can have a curved shape that is different from the shape shown in FIG. 8b.

[0094] FIGS. 9a, 9b and 9c illustrate several views of an embodiment of a foot 140 that is disposed under the tank platform 110. As seen in FIG. 1, an embodiment of a float glass system 100 may include four feet 140 that are disposed under corners of a platform 110 on which a tank 102 sits. The number of feet 140 may vary depending on the size and mass of the tank 102. Each of the feet 140 may be height adjustable, and include a load cell 950. The load cell 950 can be used to determine the mass of materials placed in a tank 102, including an amount of tin and an amount of glass that are placed in the tank. Accordingly, an embodiment may provide a degree of precision and accuracy to float glass manufacturing that is not available in conventional manufacturing processes.

[0095] In the embodiment of FIGS. 9a-9c, the feet 140 include a mounting plate 990 as a base, heat bracing 910 that braces a vertical support part of the feet, and a connecting support member 920 that may include a pivot axis about which load support 930 can pivot. The open face of load cell element 950 may interface with a corresponding surface of load support 930, support member 920, or directly on the base plate 990. Load cell 950 may be mounted to load cell housing 940, which is coupled to height adjustment shaft 960 and nut 970. The location of nut 970 may be adjusted against an ankle member 980 to adjust the height of the foot.

[0096] However, these specific components are only one example of a foot 140, and other embodiments are possible. For example, in another embodiment, a foot 140 may only be adjustable in the vertical dimension, and may or may not incorporate a load cell 950. In another embodiment, load cells 950 may be located between a tank platform 110 and an upper surface of a foot 140, or not present at all.

[0097] FIG. 10 illustrates an embodiment of a top cover 150 of a tank 102. The top cover 150 includes several refractory layers 1030 that are disposed over a cover plate 1090, which may be a metal material such as aluminum or steel. The top cover 150 may include a plurality of emitters 1010, one or more temperature sensor 1020, one or more proximity sensor 1040 and one or more fluid channel 1070. In an embodiment, the glass-facing surface of the top cover 150 is a layer of ceramic glass 1050. However, in another embodiment, no ceramic glass sheet 1050 is present. The top cover 150 may be removed to introduce glass into the tank, and to extract product glass from the tank. In an embodiment in which a material is present between the emitters 1010 and the interior of the tank, the material may transmit at least 80% or at least 90% of infrared energy in a spectrum of from 1000 nm to 4000 nm. The material may be substantially transparent to infrared energy in a spectrum of from 1000 nm to 4000 nm.

[0098] One or more contact or non-contact thermocouple 1080 may be present in the top cover 150 and configured to

measure a temperature of a ceramic glass sheet **1050** (if present), air temperature, fluid temperature, temperature of a refractory material, etc. A separate temperature sensor **1020** may be configured to measure the temperature of gas within the tank **102** when the top cover **150** covers the tank, or a temperature of radiant emissions from the emitters **1010**. In an embodiment, the temperature sensor **1020** is an optical two-wavelength emissivity compensating temperature sensor, but embodiments are not limited to that specific type of sensor.

[0099] Components in the cover **150** including the emitters and gas jets **1060** may be directly or indirectly coupled to the cover plate **1090**, so that the cover plate provides physical support for the components. In an embodiment, the refractory layers **1030** are suspended from the cover plate as described, for example, in U.S. application Ser. No. 17/347,428, the contents of which are incorporated herein by reference. In addition to or as an alternative to a suspension system, the refractory layers **1030** may be mechanically retained by mechanical elements disposed on sides of the cover **150**. In one embodiment, a ceramic glass layer **1050** is retained by a mechanical coupling to the cover **1090**, so that the ceramic glass layer **1050** retains the refractory layers **1030** in position and a metal lip **1055** enhances the fit of the cover to the refractory layers **420**, **430** of the tank side assembly **120**. In another embodiment, no ceramic glass layer **1050** is present, and the refractory layers are suspended from plate **1090**.

[0100] FIGS. **11a**, **11b** and **11c** show several stages of a float glass process. FIG. **11a** shows molten glass **1120** being poured onto a pool of molten tin **1110**, FIG. **11b** shows a puddle of molten glass **1130** floating on the molten tin, and FIG. **11c** shows a layer of glass **1140** that has spread to reach an even thickness across the surface of the tin. In an embodiment, the spreading between FIG. **11b** and FIG. **11c** may be enhanced by applying an elevated pressure to the glass.

[0101] FIG. **12** illustrates a viscosity and temperature curve **1210** of soda-lime glass, including several transition points. For example, point **1220** is at the temperature at which conventional tin baths are maintained, which is 600° C., and indicates a log viscosity of about 9 at that temperature. An embodiment of the present disclosure may operate at different temperatures for different phases of a process, at a temperature of 800° C. at point **1240**, having a log viscosity of about 5.8, or a higher temperature of 950° C., which has a log viscosity of about 4.2, as indicated by point **1230**. Since the viscosity of glass decreases rapidly with temperatures above 600° C., float glass will level substantially faster when temperatures are elevated even as low as 50° C. or 100° C. above the conventional temperature of 600° C.

[0102] FIGS. **13** and **14** show embodiments of two types of ceramic glass that could be used for a tub **210**. The ceramic glass in FIG. **13** has two passbands—the lower passband **1310** is a large passband that spans visible frequencies, and an upper passband is centered between 3500 and 4000 nm wavelengths. Also shown in that figure are multiple infrared output curves **1320** that represent different tunings of IR emitters **360**, **560**, **1010**. FIG. **14** illustrates IR transmissions for opaque ceramic glass which has two passbands, each of which are smaller than the passbands of the non-tinted glass of FIG. **13**. FIG. **14** also shows three IR output curves **1410**, **1420** and **1430**, which represent differ-

ent tunings that can be applied to an IR emitter to align IR from the emitter with passbands of the ceramic glass.

[0103] FIG. **15** illustrates an embodiment of a process **1500** for manufacturing float glass. In an automated system, parameters for a desired type of glass are input into a controller at **S1510**. The parameters may be time and temperature parameters for various phases of the process, or more generally, a desired type of glass or characteristics of a desired glass such as a desired thickness, size or heat treatment. An appropriate tank may be selected at **S1515** when multiple different tanks are available to select a size of a glass sheet, and a thickness may be selected at **S1520**. The selected thickness may be achieved by providing a predetermined amount of glass to a specific size of tank, and in some embodiments, by applying a predetermined amount of pressure when forming the glass. Accordingly, embodiments of the present application may be used to form sheets of glass with thicknesses that are less than one quarter of an inch, e.g. glass that is less than 6 mm, 5 mm, 4 mm 3 mm or 2 mm thick.

[0104] The tank **102** is heated at **S1525**. Heating the tank **102** may include activating radiant emitters in the tank to heat tin in the tank to a temperature of 600° C. or more, 650° C. or more, 700° C. or more, 750° C. or more, 800° C. or more, 850° C. or more, 900° C. or more, or 950° C. or more. An advantage of using resistive radiant heaters is the ability to heat materials rapidly and efficiently in the tank **102** to high temperatures. Efficiency is greatly enhanced compared to a lehr oven due to the highly directional heating provided by the radiant emitters, their relatively close proximity to the materials that are heated, and the relatively low mass of tin used by an embodiment of the present disclosure. Accordingly, a mass of tin that is sufficient to create float glass in a tank **102** may be heated to temperatures of 950° C. or more in several minutes or less, while it can take a day or more for a lehr to bring the tin bath to a temperature of 600° C. The tin may be heated using one or more of radiant emitters **360** in the bottom assembly **130** of the tank, radiant emitters **560** in side assemblies **120** of the tank, and radiant emitters **1010** in the top cover **150**.

[0105] Molten glass is introduced into the tank **102** at **S1535**. The molten glass may be introduced to an open top of the tank **102** with the top cover **150** removed, or introduced into an orifice that is provided in the top cover **150** or an upper portion of the side assemblies **120**. The mass of glass introduced into the tank may be measured by load cells **950**. In an embodiment, glass may be melted in a batch process by measuring an amount of solid materials appropriate for the desired size of glass sheet, melting those materials as a single batch, and introducing the melted batch of glass into the tank.

[0106] After the glass has been introduced into the tank at **S1535**, a predetermined pressure may be applied to the environmental chamber **160** by introducing or removing non-oxidizing gas from the chamber. The glass is allowed to spread to an even thickness at **S1545/S1550**. The glass is then cooled to a solid state. The rate of cooling may be chosen at **S1555** based on whether a tempered or an annealed glass is desired. In the case of tempered glass, the glass is cooled rapidly at **S1570**. Cooling the glass may include removing heat using fluid in one or more of fluid channels **322**, **590** and **1070**, and/or introducing gas into one or more of gas jets **321**, **580** and **1060**. The glass may be

cooled to a temperature of about 250° C., at which the glass can be grasped by a suction system and lifted from the tank.

[0107] After it has been removed from the tank, the sheet of glass may be set aside and allowed to cool to room temperature. Depending on the desired size of a sheet of glass and the condition of edges of the sheet, edges of the sheet of glass may be trimmed at S1590.

[0108] FIGS. 16, 17, 18 and 19 illustrate embodiments of an apparatus for producing a curved or otherwise shaped sheet of glass. The reduced viscosity of the glass and the control of the temperature of the tin enable the ability to remove the molten tin 1620 through nozzles 1650 and to allow the glass 1630 to drape over a submerged mold or shape constraint 1710, 1810, 1910 that will be used to shape the glass by gravity or by gas pressure. By controlling the rate of cooling, an annealed or tempered curved glass product can be produced in a single step. This process can produce a curved annealed or tempered glass product using up to 90% less energy as compared to a conventional curved, tempered glass process where the glass is heated at least three times.

[0109] The mold at the base of the tank 1610 may have any of a variety of three-dimensional shapes. For example, as illustrated in FIG. 17, the mold may have a face with convex curves that extend in two orthogonal axes. In the embodiment of FIG. 18, the mold 1810 has concave curves oriented in two orthogonal axes, while FIG. 19 illustrates an embodiment in which the mold is shaped with a set of sinusoidal curves. Of course, these shapes are merely examples, and embodiments of the mold may have any number of shapes or contours in three dimensions, including shapes with multiple or compound curves and angled flat surfaces.

[0110] Forming a sheet of shaped glass using a mold 1810 in a tank 1610 may include introducing molten glass 1630 onto a layer of molten tin 1620 and cooling until the glass solidifies while still retaining sufficient heat to be deformed. In an embodiment, the glass is cooled to a temperature at which it conforms to the shape of the mold 1810 under the force of gravity. For more challenging geometries, conforming to the mold 1810 may be assisted by applying a gas to a space above the glass to force the glass against the mold, and/or applying a negative pressure to a space between the glass and the mold 1810 by applying a vacuum through one or more nozzles 1650. The glass sheet may be cooled passively, or actively, as described above. When the glass is actively cooled, the rate of cooling may be controlled to anneal or temper the molded sheet of glass within the tank 1610.

[0111] Forming a sheet of shaped glass may include providing a predetermined volume of tin to a tub in a tank with a lower surface having a three-dimensional shape. The predetermined volume of tin may be selected to provide sufficient tin to cover the mold to present a flat surface onto which molten glass 1630 is introduced. The tin may be heated by a first plurality of infrared emitters to heat the tin to maintain a molten state while the glass sheet cools to a solid state on the surface of the tin. The tin may be introduced in a molten state, or in alternatively in a solid state, in which case the tin is heated to a molten state before introducing the molten glass 1630.

[0112] Although the figures illustrate two nozzles 1650, embodiments may have a larger number of nozzles depending on the size and shape of the glass being produced. For

example, for a mold 1910 with a sinusoidal curved surface, one or more nozzle 1650 may be disposed at the base of the mold trough for each of the curves. Nozzles 1650 may be arranged to remove a majority of the liquid tin from the tank 1610. In an embodiment, the base of tub 1610 has a manifold system which provides a flow path between the base of a mold 1810 and one or more nozzle 1650 for the removal of liquid tin 1620. A manifold system has the benefit of facilitating replacing molds 1810 from a tank 1610 while using the same set of nozzles 1650 that can be fixed to a base of the tank 1610.

[0113] The nozzles 1650 may comprise a material that retains sufficient engineering properties at the temperature of liquid tin. For example, the nozzles 1650 may comprise a metal or ceramic material. The nozzles 1650 may be equipped with or coupled to a mechanical system to switch between open and closed states. In an embodiment, the nozzle has a ceramic component that interfaces with the mold.

[0114] In addition, the nozzles 1650 may be coupled to a vacuum system to apply a negative pressure to the space beneath the sheet of glass in a thermoforming operation. In addition, or as an alternative, a positive pressure may be applied to the space above a sheet of heated glass to press the glass into position against the mold 1810. In such an embodiment, the top cover 150 of the tank 1610 may be sealed to the tank.

[0115] Although FIGS. 16-19 show simplified views of a tank 1610, the tank 1610 may have the same features of tank 102 discussed above. For example, the tank 1610 may have one or more wall that comprises a ceramic glass material, and infrared emitters 360, 560 and 1010 may be incorporated into one or more of the base, sides and cover of the tank.

[0116] The mold 1810 may be a removable component that can be replaced within a tank 1610 to form different shapes of glass using the same tank. In another embodiment, the mold 1810 is integrated with the tub 210 as the bottom face of the tub.

[0117] The mold 1810 may be a ceramic material. For example, the mold may be a ceramic glass material that is partially absorptive of infrared radiation as described above. In such an embodiment, the infrared emitters 360 transfer heat through the thickness of the mold material, and the mold material conductively transfers heat to the tin, and after the tin is removed, the mold transfers heat conductively to the sheet of glass. In another embodiment, the mold is a ceramic or glass material that is transparent to infrared frequencies to allow a greater amount of the infrared radiation from emitters below the tub 210 to reach the tin.

[0118] In another embodiment, a tank 102 may be used for a general heating process, such as melting a metal material. The tank used to melt metal materials may have components of the tanks described above, including ceramic glass surfaces and a plurality of infrared radiant emitters directed towards the interior of the tank and radiating through the ceramic glass material. The physical construction of the tank provides a high level of control and responsiveness in the management of the temperature of the liquid metal bath.

[0119] As noted above, the tank 102 may be heated to temperatures above 950° C. Accordingly, the tank can be used to melt a variety of metals, including zinc, tin, aluminum, lead, and silver, alloys and blends such as brass, and various composite materials. In some embodiments, the tank

may be used to melt copper and gold. Metals that are melted by the tank may be loaded into the tank in the form of ingots.

[0120] FIGS. 20a, 20b and 20c illustrate an embodiment of a process for melting a material according to embodiments of the present disclosure. An apparatus within the scope of the present disclosure is capable of high precision control for heating, cooling, and load measurements, and can be heated to a target temperature within a wide range of temperatures with much higher speed and precision than conventional processes. Accordingly, embodiments provide highly efficient short startup and cool down times as well as precise production on demand.

[0121] Referring to FIG. 20a, a heating or melting process may include introducing media 2020 to be heated into a tank. The media may be loaded into a basket 2010, and then the basket may be placed inside the tank. In an embodiment, the basket includes a plurality of perforations. The perforations reduce thermal mass and facilitate heat transfer between the tank and the media 2020. For example, the basket may comprise a wire mesh that is constructed to have minimal surface area while retaining sufficient strength to transport the media 2020. The basket 2010 material may be a material that retains physical properties at elevated temperatures, such as a ferrous or non-ferrous metal alloy, molybdenum, or a ceramic, while lower temperature processes can use a basket with lower cost materials.

[0122] The basket 2010 may have two or more handles 2030 that protrude from the sides of the basket. As indicated in FIG. 20b, the handles 2030 may extend over an upper rim of the tank to keep the bottom of the basket 2010 raised above the lower surface or bottom plate 820 of the tank when the media is loaded into the tank. In such an embodiment, when the media 2020 is heated, the media may melt and flow through perforations in the base of the basket, and the basket may be removed from the tank without touching surfaces of ceramic glass material of the tank. The number and shape of handles 2030 may vary between embodiments—for example, four handles may be present, and in another embodiment, the handle may be a single piece of material that extends across the entire width of the basket 2010.

[0123] Sides of the tank may be shaped to accommodate the handles 2030 so that the handles do not interfere with a top cover 150 when it is positioned over the tank. Similarly, the top cover 150 may be shaped to accommodate protrusions of the basket. In another embodiment, the basket 2010 may be fastened to the top cover 150 so that the basket is loaded into the tank when the top cover is placed over the tank.

[0124] In an embodiment, the liquid metal may be both heated and cooled to control its temperature. The temperature of the liquid metal may be monitored simultaneously with the temperature of the ceramic glass containing the liquid metal bath. The apparatus heating the liquid metal using incorporated tunable infrared emitters 360, 560 which can pass infrared thermal energy through the ceramic glass 810, 820 may also employ non-oxidizing gas jets 321, 580 and conduction fluid heat exchangers 322, 580 on the surface of the ceramic glass to cool the liquid metal 2010 by cooling the ceramic glass. The ceramic glass is in contact with the liquid metal which is cooled by conduction.

[0125] In still another embodiment, at least a portion of basket 2010 is a non-perforated material. For example, at least a lower part of basket 2010 may comprise a single

contiguous piece of net-shape formed or machined ceramic material that is free of gaps or seams and retains media 2020 after it has been melted. Such an embodiment may be useful for rapidly loading, melting, and unloading batches of media 2020 while the tank remains in a stationary position. In another embodiment, the basket 2010 may be assembled from non-perforated sheets of ceramic glass material in a similar manner to the assembled plates described above with respect to FIGS. 8a-8c, for example.

[0126] In still another embodiment, media 2020 is loaded directly into a tank without being placed in a basket 2010.

[0127] Returning to FIG. 20c, when a perforated basket 2010 is used, the basket may be removed, leaving a pool of melted media 2040 in the tank. Subsequently, the melted media 2040 may be scooped or poured from the tank in the molten state to facilitate, e.g., a casting process. In another embodiment, the melted media 2040 is allowed to cool, and is removed in a solid state, which may be useful when forming an alloy from a blend of various media 2040.

[0128] Embodiments of the present disclosure have several advantages over conventional processes. In traditional natural gas furnace technologies, the liquid metal bath has a significant volume to assist in stabilizing the temperature of the bath which is heated from above. Such technologies are designed to maintain a continuous temperature—the heating process is relatively slow, and after the target temperature is reached, it is maintained for as long as possible. Accordingly, such technologies are typically run at a melt temperature of the target media for days, weeks, or longer to avoid the substantial cost of time and energy associated with cooling and heating using natural gas.

[0129] In contrast, embodiments of the present disclosure can efficiently deliver heat from infrared emitters to a media primarily through radiation and conduction from partially absorptive ceramic glass materials, thereby raising media to its melting point within seconds or minutes, depending on the volume of media and amount of energy delivered. Accordingly, embodiments of the present disclosure can operate intermittently and be used efficiently for small batch processes. Furthermore, due at least in part to the highly directed and efficient energy transfer, the amount of energy consumed by embodiments of the present disclosure can be much lower than processes that rely on natural gas, and can result in drastically lower greenhouse gas emissions.

[0130] For some applications, a melt process can operate with a minimal molten media bath volume. The control is fast enough that metals can be heated and cooled on demand to temperatures above 950° C. to adapt the pool to meet process or production needs.

[0131] In an embodiment, the location of the top surface of liquid media 2040 in the tank may be controlled with respect to the location of the cover assembly 150. As illustrated in FIG. 10, the cover assembly 150 may incorporate tunable infrared emitters 1010, non-oxidizing gas cooling jets 1060 and a conduction fluid heat exchanger 1070.

[0132] The position of the top apparatus 150 may be adapted using radio frequency proximity sensors 1040 to enable the positioning of the top ceramic glass 1050 within distances of, for example, fractions of a millimeter to provide effective non-contact heating and cooling of the surface of the liquid media 2040 in the tank. In such an embodiment, a gap may be present between the cover assembly 150 and side assemblies 120 of the tank 102 to

accommodate raising and lowering of the cover assembly. The location of the cover assembly **150** may be changed throughout the melting process to maintain a very close distance to the media as it melts and expands and contracts in accordance with a coefficient of thermal expansion. In another embodiment, the tank may be sealed when the cover assembly **150** is placed onto the tank **102**.

[0133] In an embodiment, the entire liquid metal thermal management apparatus is enclosed in an environmental chamber **160** which may provide a variable pressure non-oxidizing or reducing atmosphere which can be regulated between very small absolute pressures of 1 Torr and large pressures up to and greater than 5,000 Torr, for example. In an embodiment, the chamber **160** may be evacuated, flushed with a forming gas, and re-evacuated to reduce or eliminate the chance of oxidation of melted media **2040**.

[0134] In one implementation, an apparatus for producing float glass comprises a tank, and the tank comprises a tub with a bottom and four sides, the tub having a usable temperature of at least 950° C., four side assemblies, a bottom assembly including a first plurality of infrared emitters directed towards the tub, and a top cover assembly including a second plurality of infrared emitters directed towards the tub. The bottom of the tub may comprise a material with a transmissivity of at least 30% in a first frequency of the infrared spectrum, and the infrared emitters emit radiation in frequencies corresponding to the first frequency. The material of the tub may pass at least 50% of infrared energy in the first frequency. Emitters of the first plurality of infrared emitters may be disposed in openings in a layer of refractory material included in the bottom assembly.

[0135] In the implementation, an outer surface of each of the side assemblies is a sheet of metal or ceramic material, and a side support assembly is coupled to each respective sheet. Each side support assembly may be configured to hold the respective side assembly in place against adjacent side assemblies and the bottom assembly. The side support assemblies may have at least three degrees of freedom of adjustability.

[0136] In the implementation, each of the side assemblies comprises a plurality of layers of refractory material that are fitted over protrusions that are fixed to a side plate that is an outer layer of the side assembly. The bottom assembly may include a plurality of layers of refractory material that are fitted over structures that protrude from a bottom plate of the bottom assembly. The implementation may further include an environmental chamber surrounding the tank, and the side assemblies may have trapezoidal shapes in which the width of the trapezoidal shapes increases with height. A depth of the tub may be no more than 16 inches in an embodiment.

1. (canceled)

2. A heating system configured to form a sheet of glass with a three-dimensional shape, the heating system comprising:

four side interior surfaces;

a bottom interior surface with the three-dimensional shape;

at least one radiant emitter configured to deliver infrared energy to an interior of the heating system; and

at least one drain nozzle respectively coupled to at least one opening in the bottom interior surface.

3. The heating system of claim 2, wherein one or more radiant emitter of the at least one radiant emitter is below the bottom interior surface and oriented to deliver infrared energy towards the bottom interior surface.

4. The heating system of claim 2, wherein the bottom interior surface comprises a ceramic glass material.

5. The heating system of claim 4, wherein the bottom interior surface is integral to a tub of the heating system.

6. The heating system of claim 4, wherein the bottom interior surface is defined by a removable mold.

7. The heating system of claim 3, further comprising at least one vacuum nozzle coupled to a vacuum system and configured to apply a negative pressure to the interior of the heating system.

8. The heating system of claim 2, further comprising a manifold system which provides a flow path between the one or more opening and the drain nozzle.

9. The heating system of claim 2, further comprising a mechanical system configured to switch between open and closed states of the drain nozzle.

10. The heating system of claim 2, further comprising four side assemblies, each of the side assemblies including at least one side radiant emitter and a side ceramic glass material providing the four side interior surfaces, each side radiant emitter being configured to deliver infrared energy through the respective side ceramic glass material.

11. The heating system of claim 10, wherein the four sides of the tank are coupled to a base by adjustable mechanical assemblies.

12. The heating system of claim 2, wherein the four side interior surfaces have trapezoidal shapes.

13. The heating system of claim 2, further comprising a base with adjustable mechanical assemblies.

14. The heating system of claim 2, further comprising a sealed environmental chamber enclosing the tank.

15. The heating system of claim 2, further comprising a top cover assembly, the top cover assembly including at least one top radiant emitter configured to deliver infrared energy to the interior of the heating system.

16. The heating system of claim 2, wherein at least one of the four side interior surfaces comprise a ceramic glass material that transmits at least 30% of energy in a first frequency of the infrared spectrum, and the at least one radiant emitter is configured to deliver the energy in the first frequency of the infrared spectrum through the ceramic glass material.

17. The heating system of claim 2, wherein the bottom interior surface comprises a ceramic glass material that transmits at least 30% of energy in a first frequency of the infrared spectrum, and the at least one radiant emitter is configured to deliver the energy in the first frequency of the infrared spectrum through the bottom interior surface.

18. A heating system comprising:

four side interior surfaces;

a bottom interior surface with the three-dimensional shape, the bottom interior comprising a ceramic glass material;

a bottom radiant emitter configured to deliver infrared energy through the bottom interior surface; and

at least one drain nozzle respectively coupled to at least one opening in the bottom interior surface.

19. The heating system of claim 18, further comprising: four side radiant emitters configured to respectively deliver infrared energy through the four side interior

surfaces, wherein the four side interior surfaces comprise the ceramic glass material.

20. The heating system of claim **19**, wherein the ceramic glass material transmits at least 30% of energy in a first frequency of the infrared spectrum, and the infrared energy delivered by the bottom radiant emitter and the four side radiant emitters includes energy in the first frequency of the infrared spectrum.

21. A heating system with a tank, the tank comprising:
a bottom assembly including at least one bottom radiant emitter and a bottom ceramic glass material, the bottom radiant emitter being configured to deliver infrared energy through the bottom ceramic glass material; and
four side assemblies, each of the side assemblies including at least one side radiant emitter and a side ceramic glass material on an inner surface of the tank, the side radiant emitters being configured to deliver infrared energy through the respective side ceramic glass materials,

wherein a bottom interior surface of the tank has a three-dimensional shape.

* * * * *