



US 20210208032A1

(19) **United States**

(12) **Patent Application Publication** (10) **Pub. No.: US 2021/0208032 A1**

Page et al. (43) **Pub. Date: Jul. 8, 2021**

(54) **LIQUID TO LIQUID BIOLOGICAL PARTICLE CONCENTRATOR WITH DISPOSABLE FLUID PATH**

(71) Applicant: **InnovaPrep LLC**, Drexel, MO (US)

(72) Inventors: **Andrew Edward Page**, Smithton, MO (US); **Zachary A. Packingham**, Drexel, MO (US); **David Scott Alburty**, Drexel, MO (US); **Alec D. Adolphson**, Raymore, MO (US)

(21) Appl. No.: **17/209,434**

(22) Filed: **Mar. 23, 2021**

Related U.S. Application Data

(63) Continuation of application No. 15/431,655, filed on Feb. 13, 2017, now Pat. No. 10,955,316, which is a continuation of application No. 14/191,205, filed on Feb. 26, 2014, now Pat. No. 9,574,977, which is a continuation-in-part of application No. 14/084,385, filed on Nov. 19, 2013, now Pat. No. 9,593,359, which is a continuation of application No. 12/882,188, filed on Sep. 14, 2010, now Pat. No. 8,584,535.

(60) Provisional application No. 61/769,672, filed on Feb. 26, 2013, provisional application No. 61/276,737, filed on Sep. 17, 2009.

Publication Classification

(51) **Int. Cl.**
G01N 1/10 (2006.01)
G01N 1/34 (2006.01)
G01N 1/40 (2006.01)
G01N 1/14 (2006.01)
(52) **U.S. Cl.**
CPC *G01N 1/10* (2013.01); *G01N 1/34* (2013.01); *G01N 2001/4088* (2013.01); *G01N 1/14* (2013.01); *G01N 1/4077* (2013.01)

(57) **ABSTRACT**

Highly efficient and rapid filtration-based concentration devices, systems and methods are disclosed with sample fluidic lines and a filter packaged in a disposable tip which concentrate biological particles that are suspended in liquid from a dilute feed suspension. A sample concentrate or retentate suspension is retained while eliminating the separated fluid in a separate flow stream. The concentrate is then dispensed from the disposable tip in a set volume of elution fluid. Suspended biological particles include such materials as proteins/toxins, viruses, DNA, and/or bacteria in the size range of approximately 0.001 micron to 20 microns diameter. Concentration of these particles is advantageous for detection of target particles in a dilute suspension, because concentrating them into a small volume makes them easier to detect. A single-use pipette tip includes fluid ports for aspirating the sample and connecting to a concentrating unit.

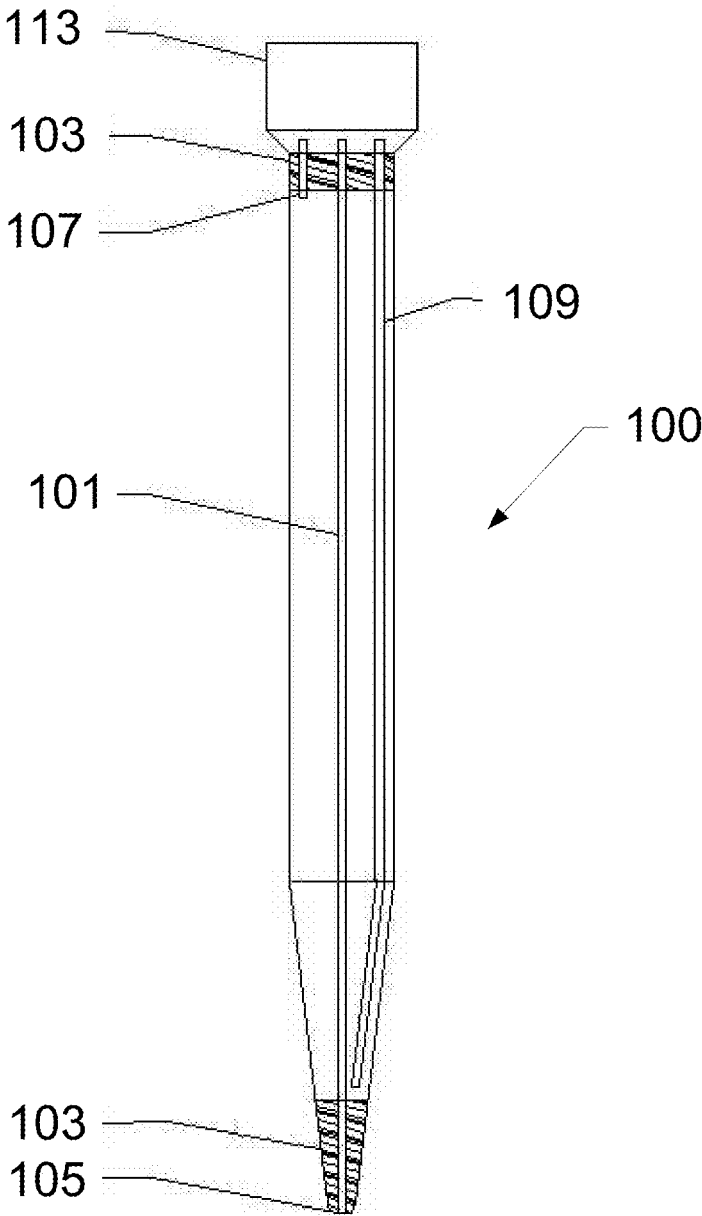

FIG. 1A

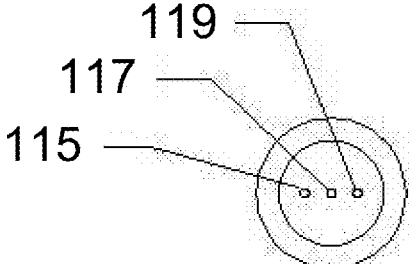

FIG. 1B

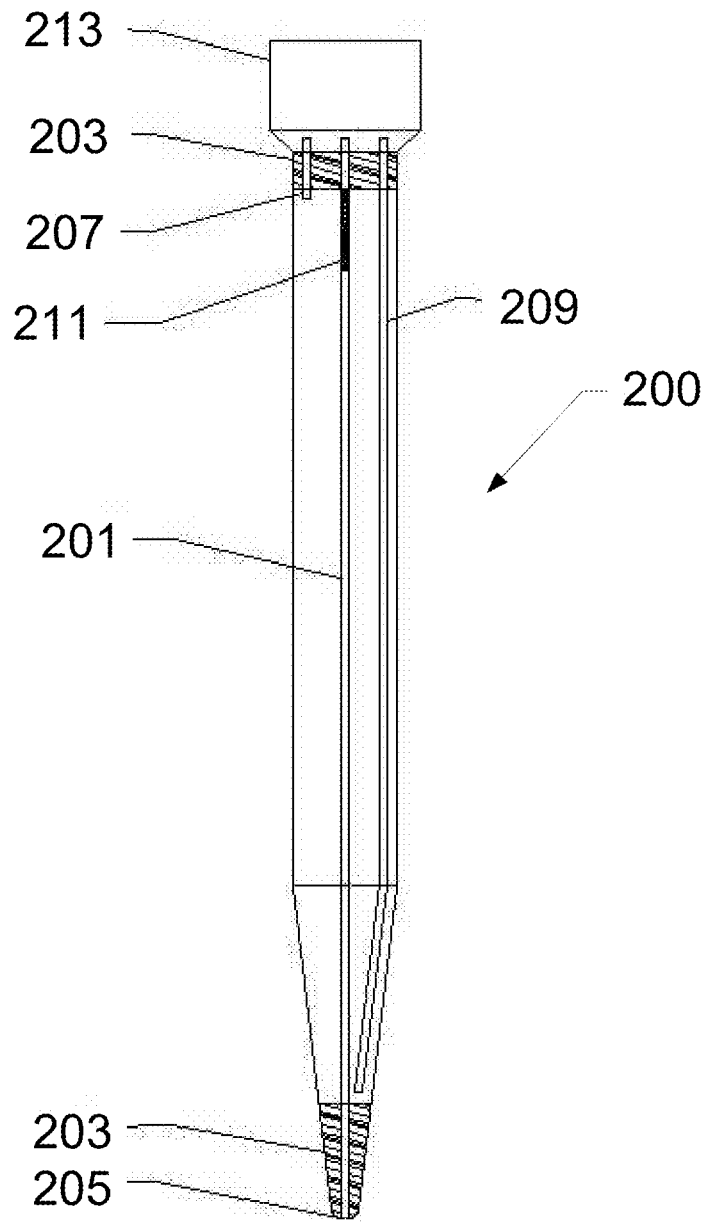

FIG. 2A

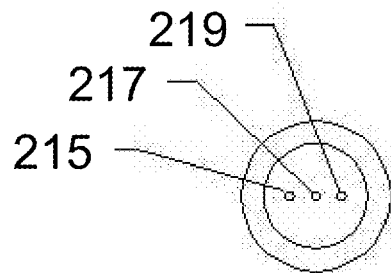

FIG. 2B

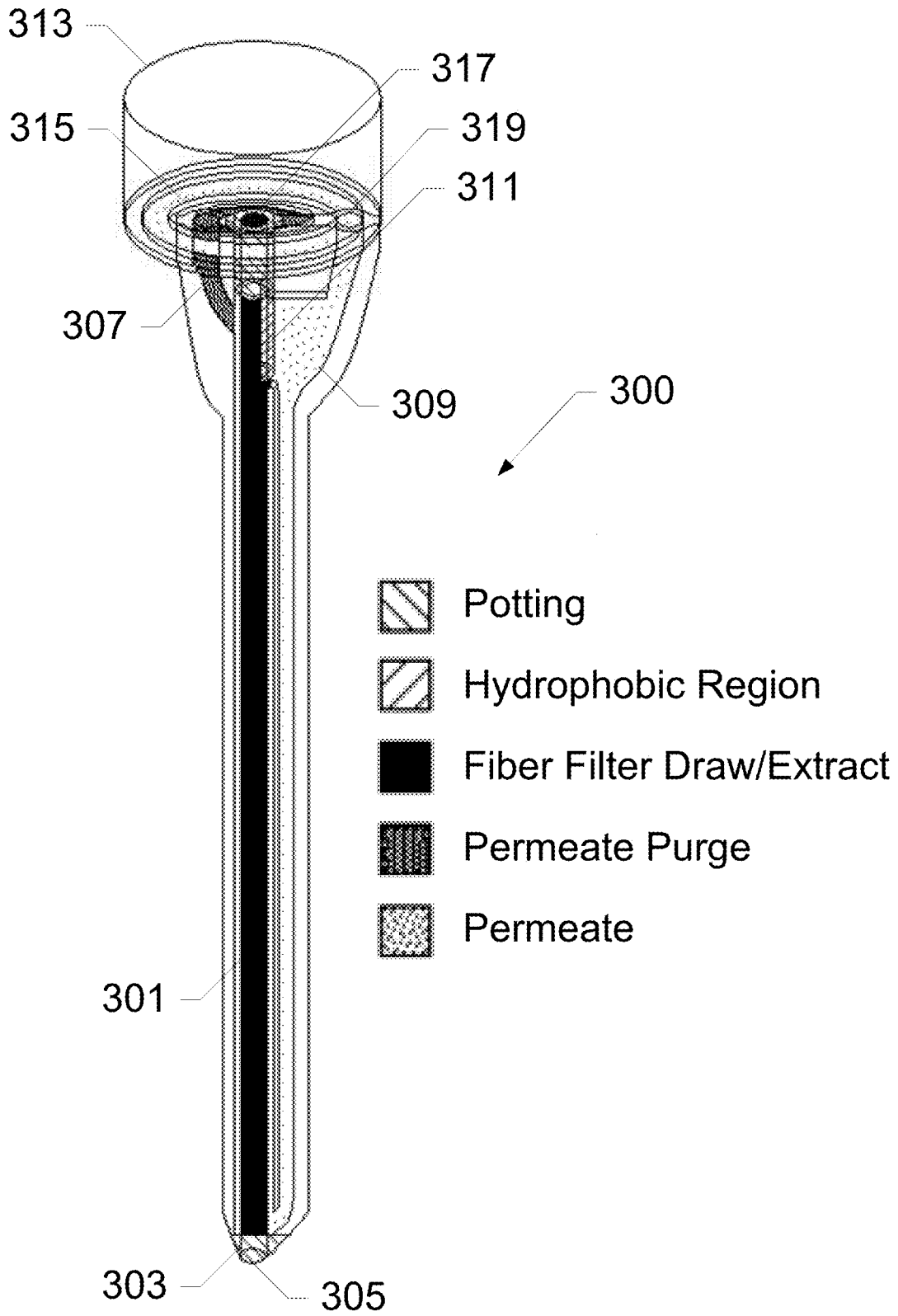

FIG. 3

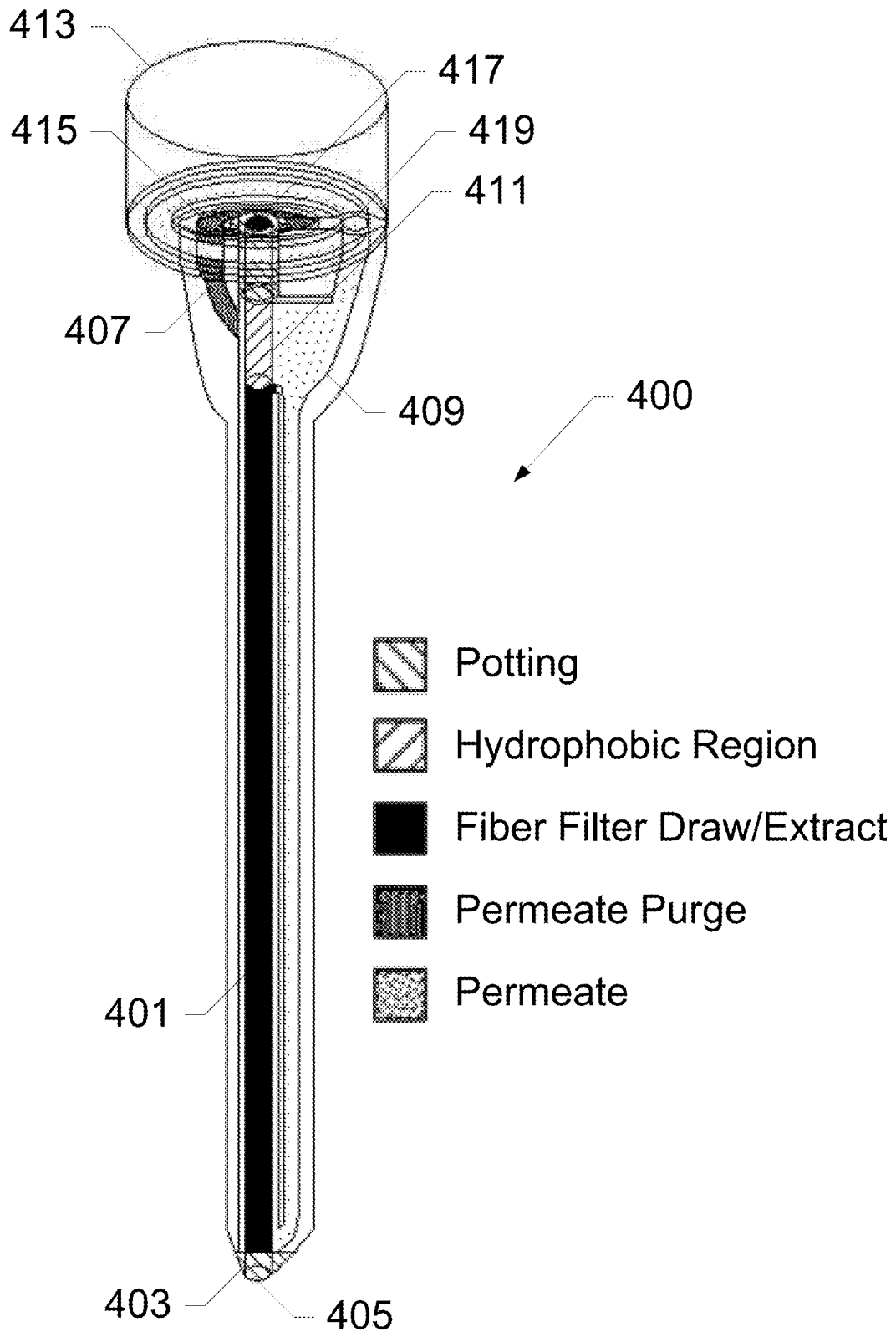

FIG. 4

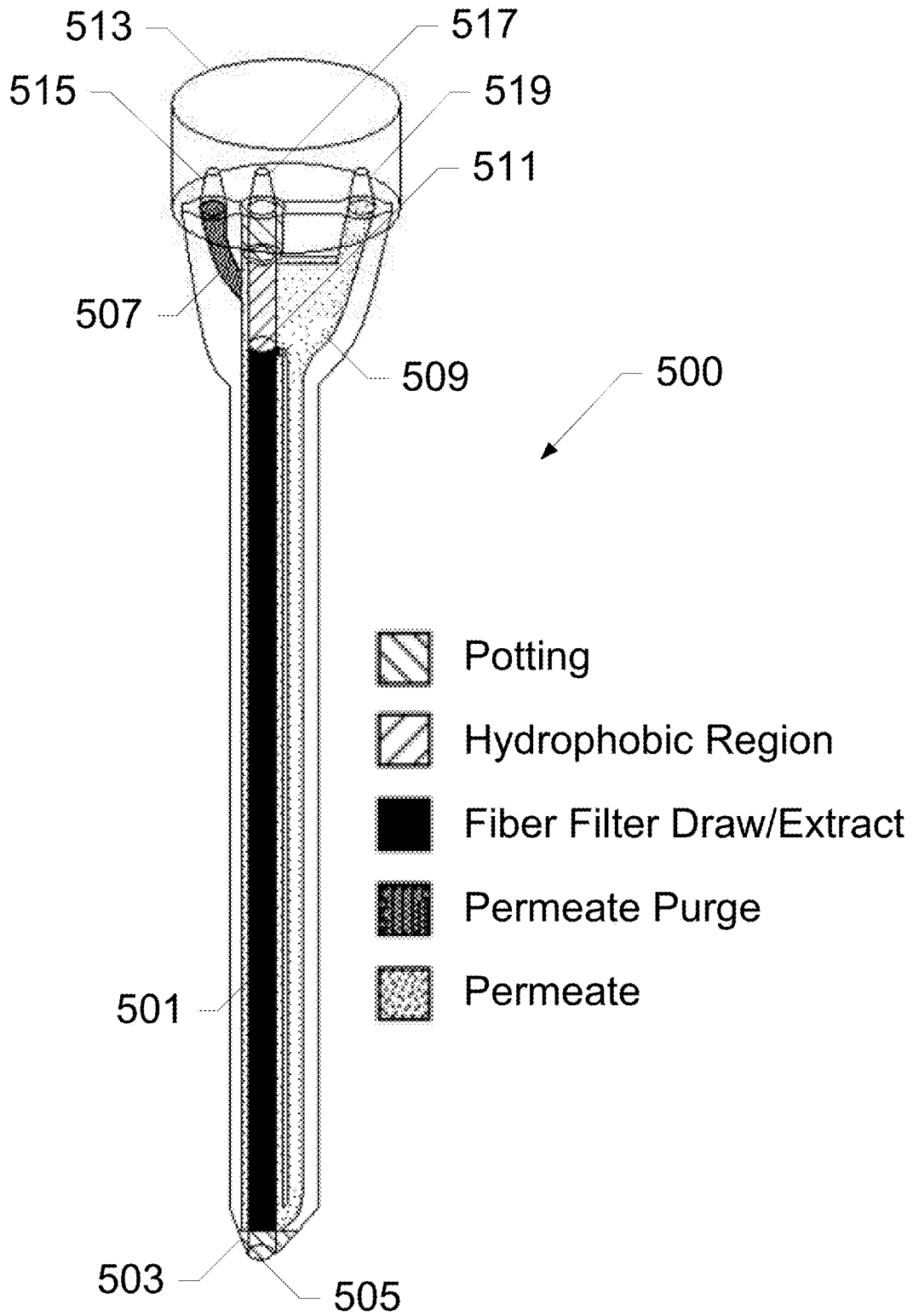

FIG. 5

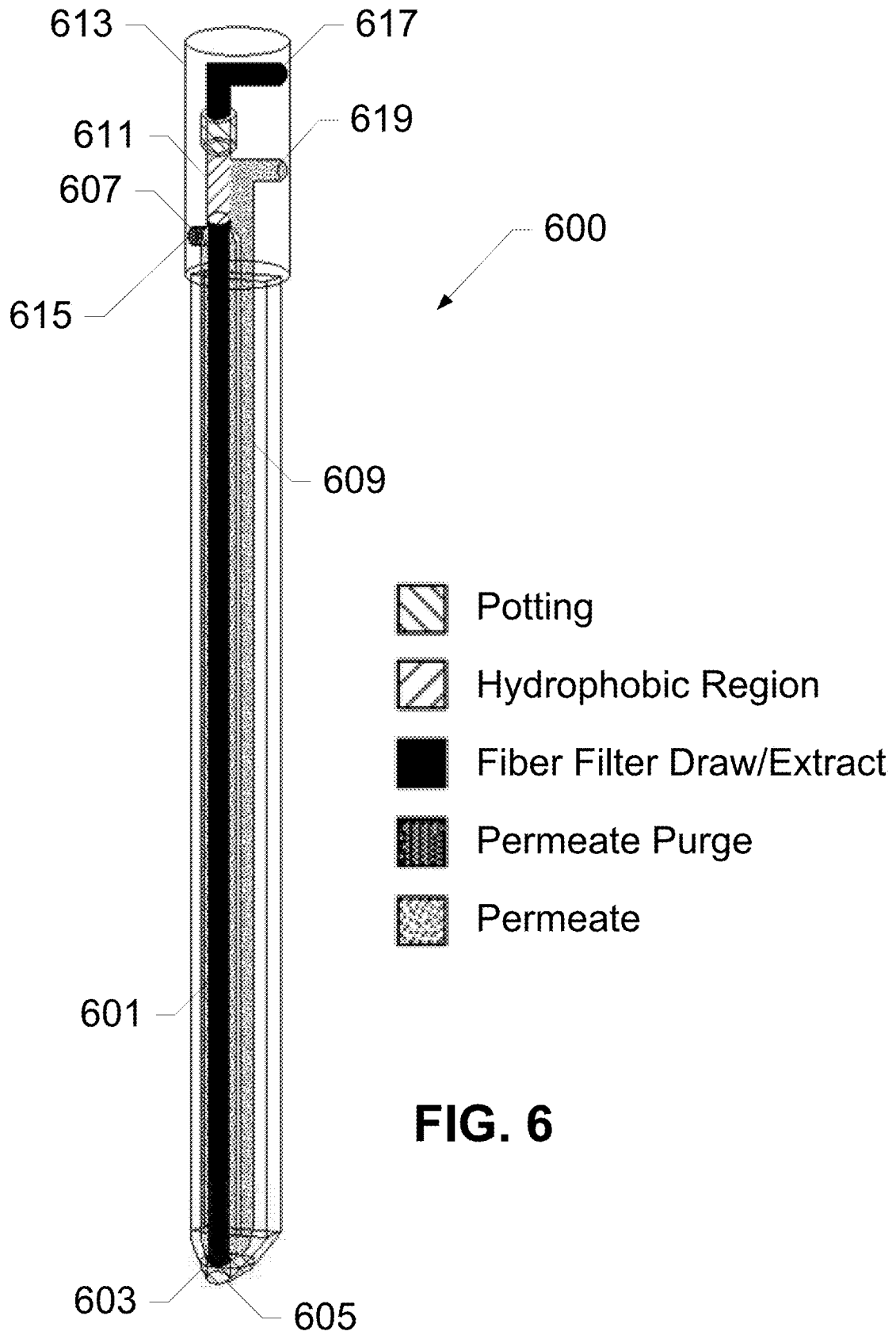

FIG. 6

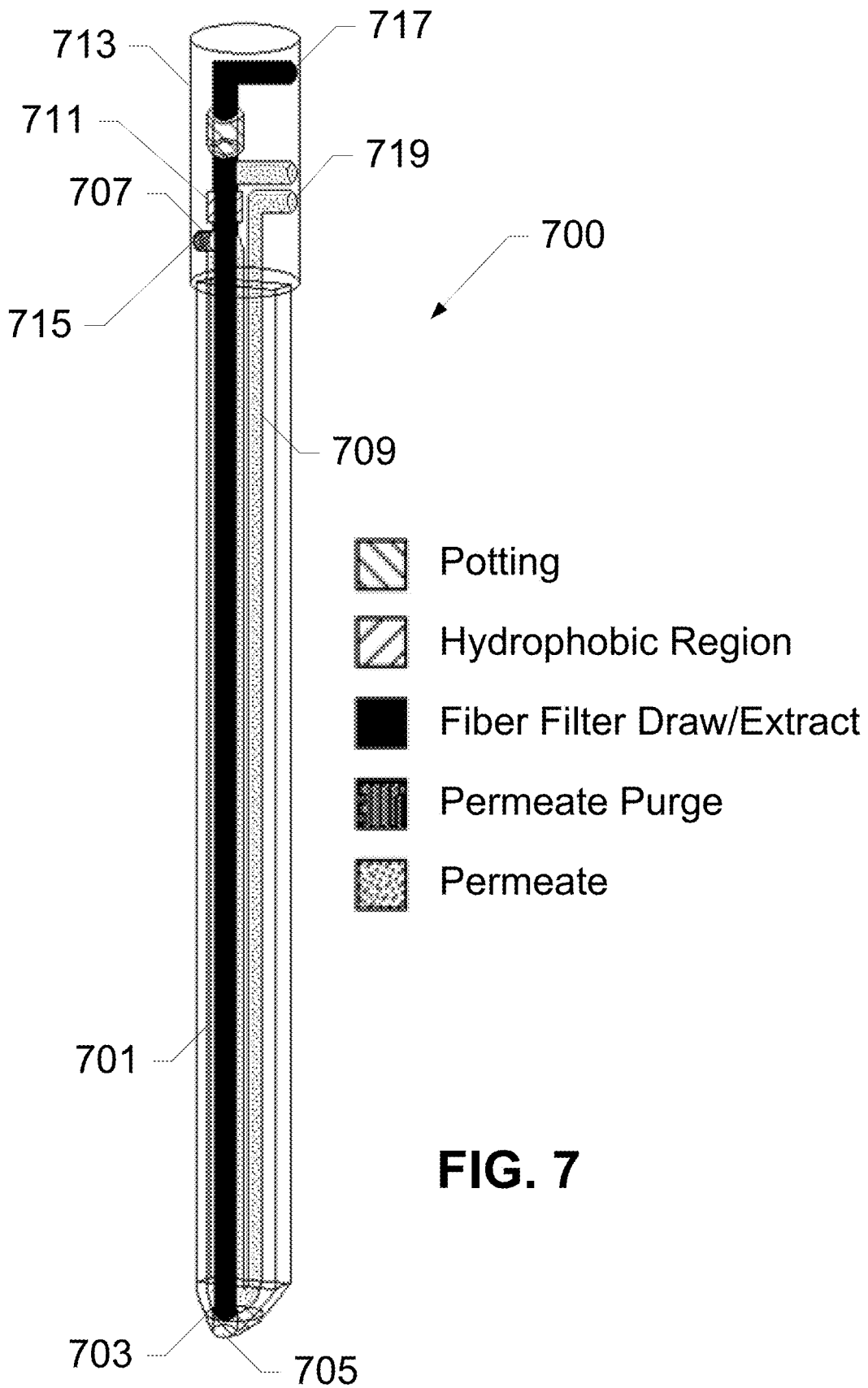

FIG. 7

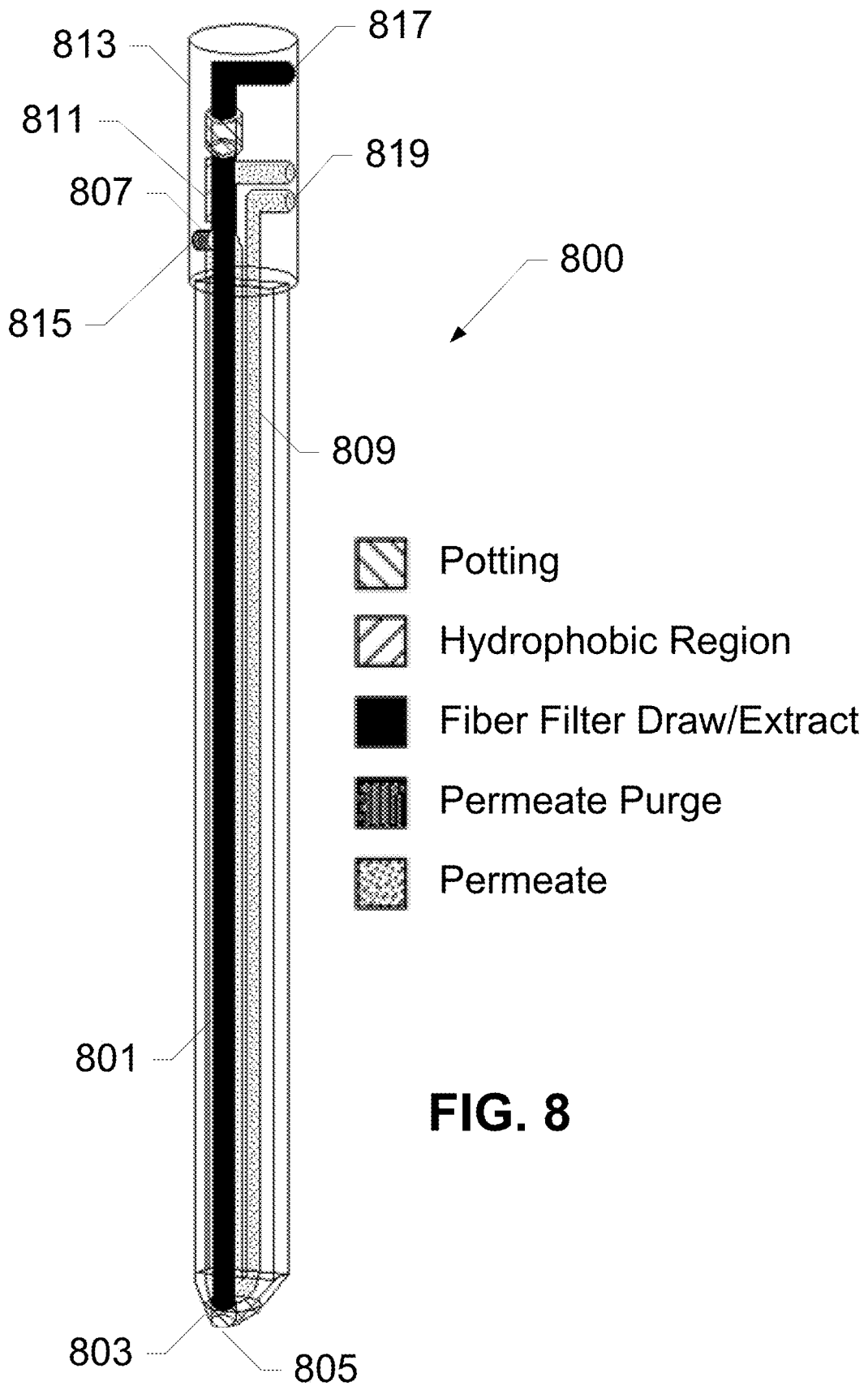

FIG. 8

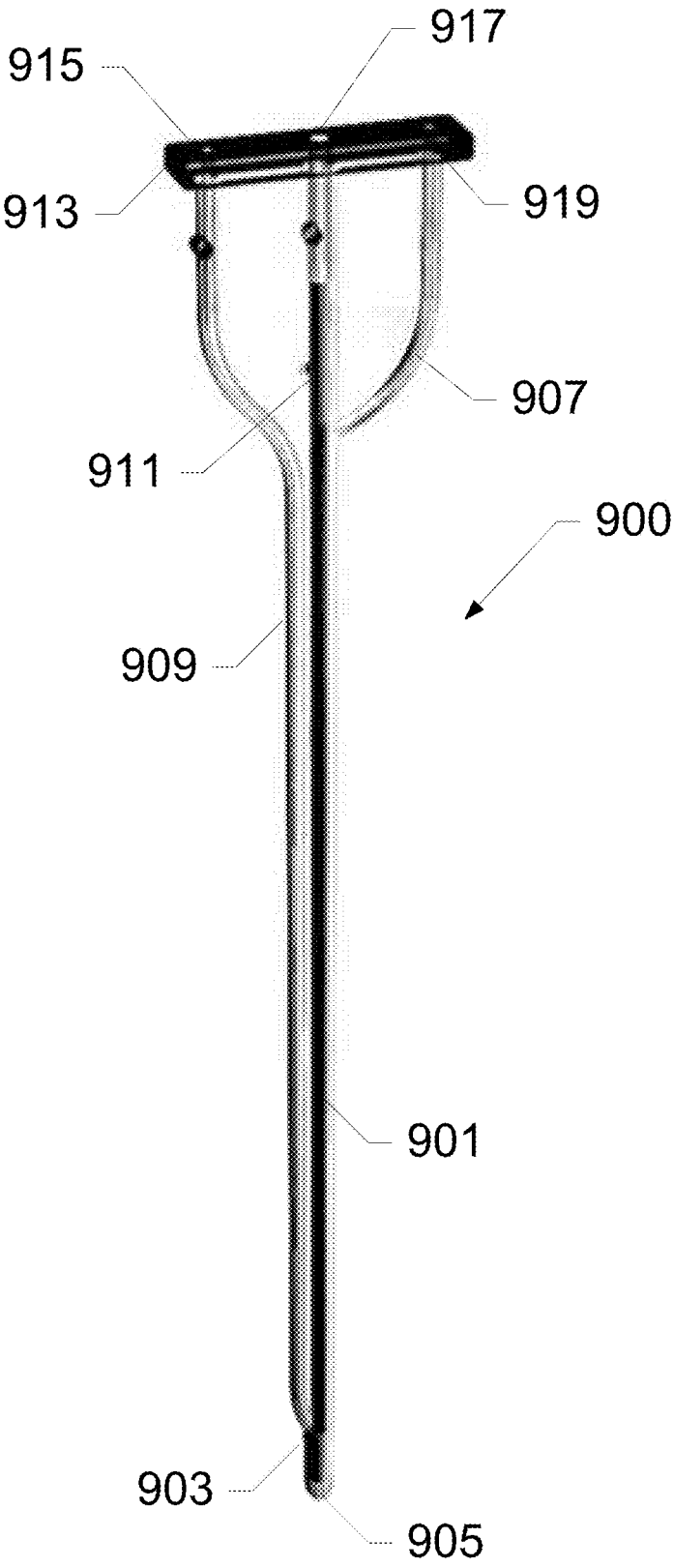

FIG. 9

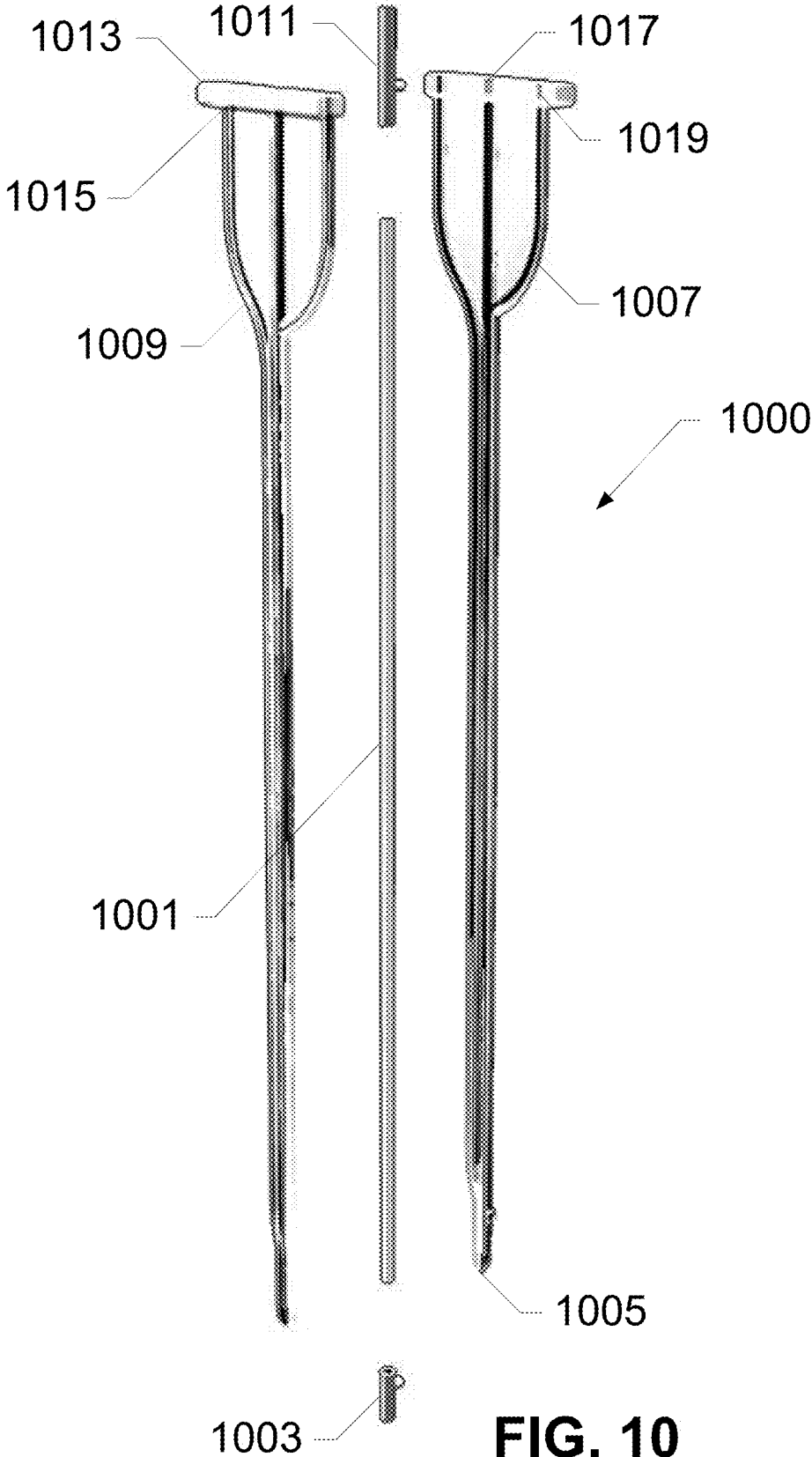

FIG. 10

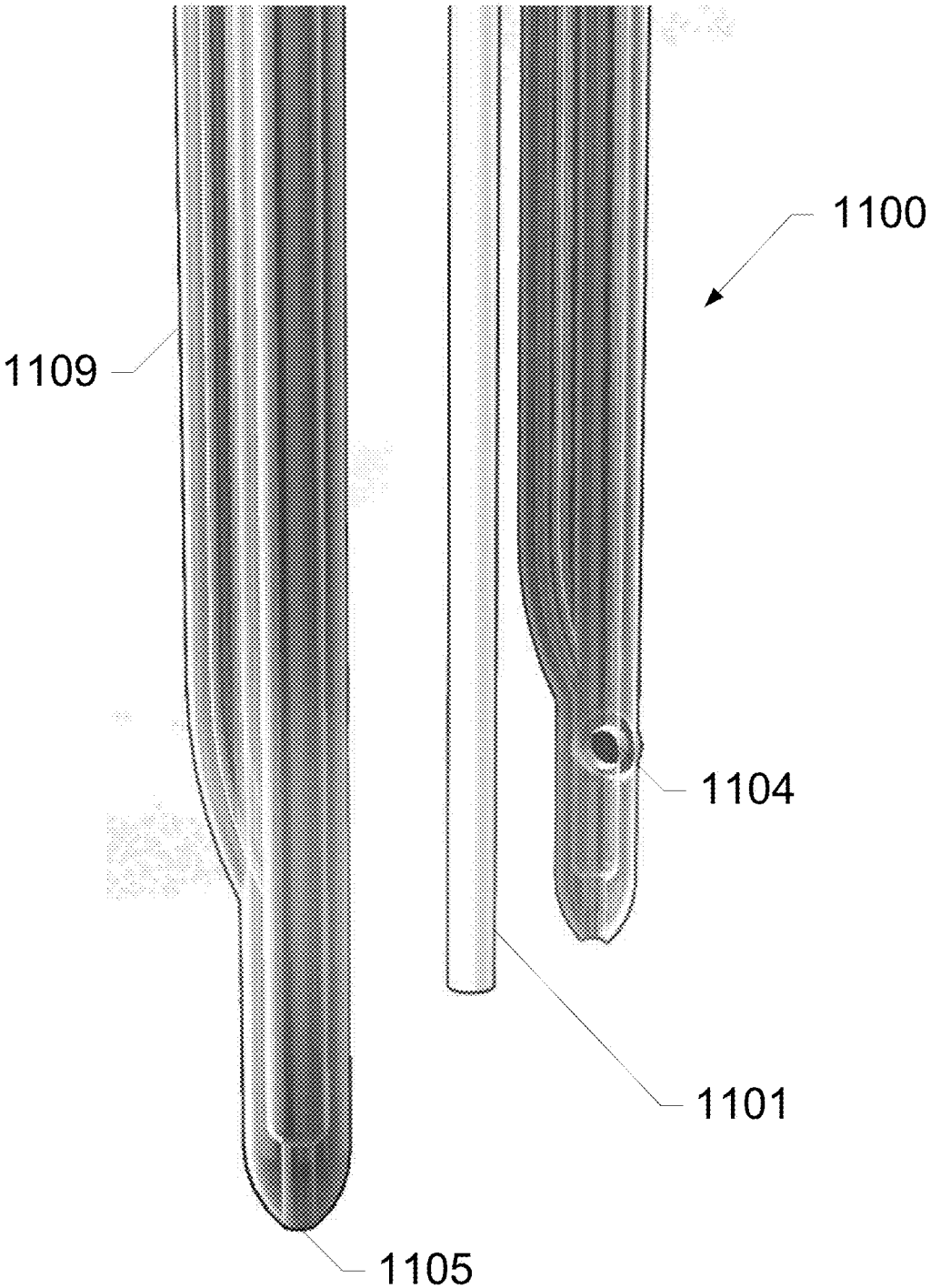

FIG. 11

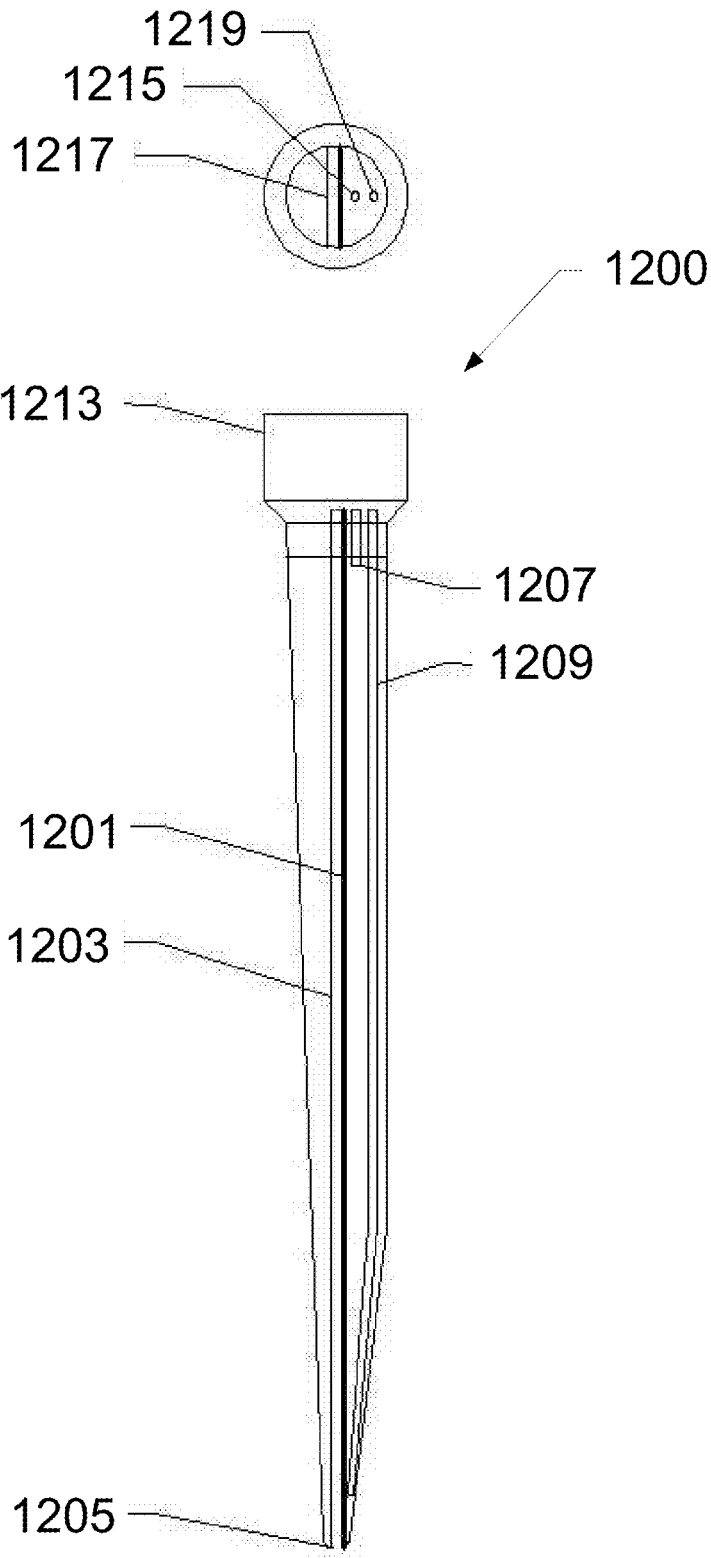

FIG. 12

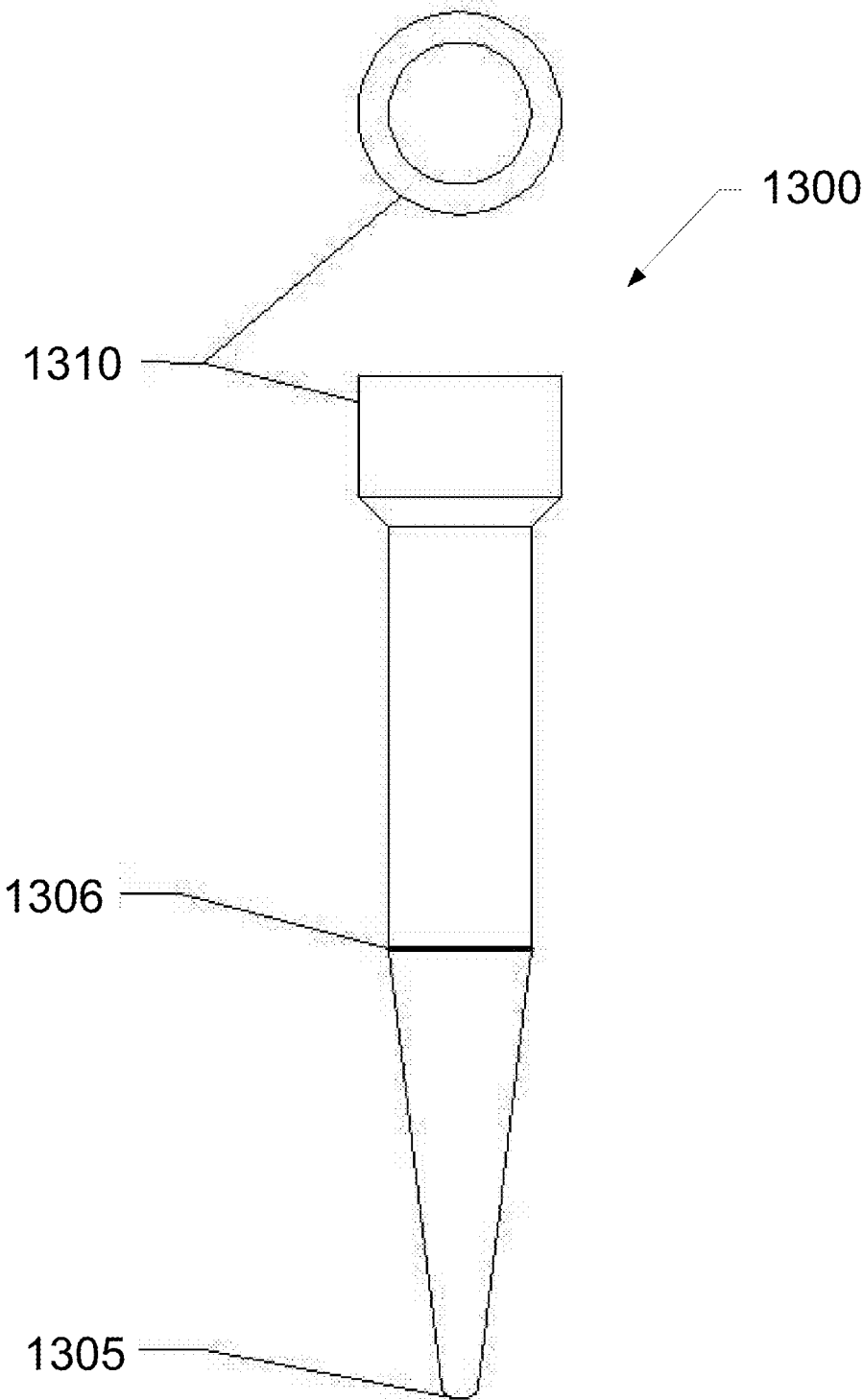

FIG. 13

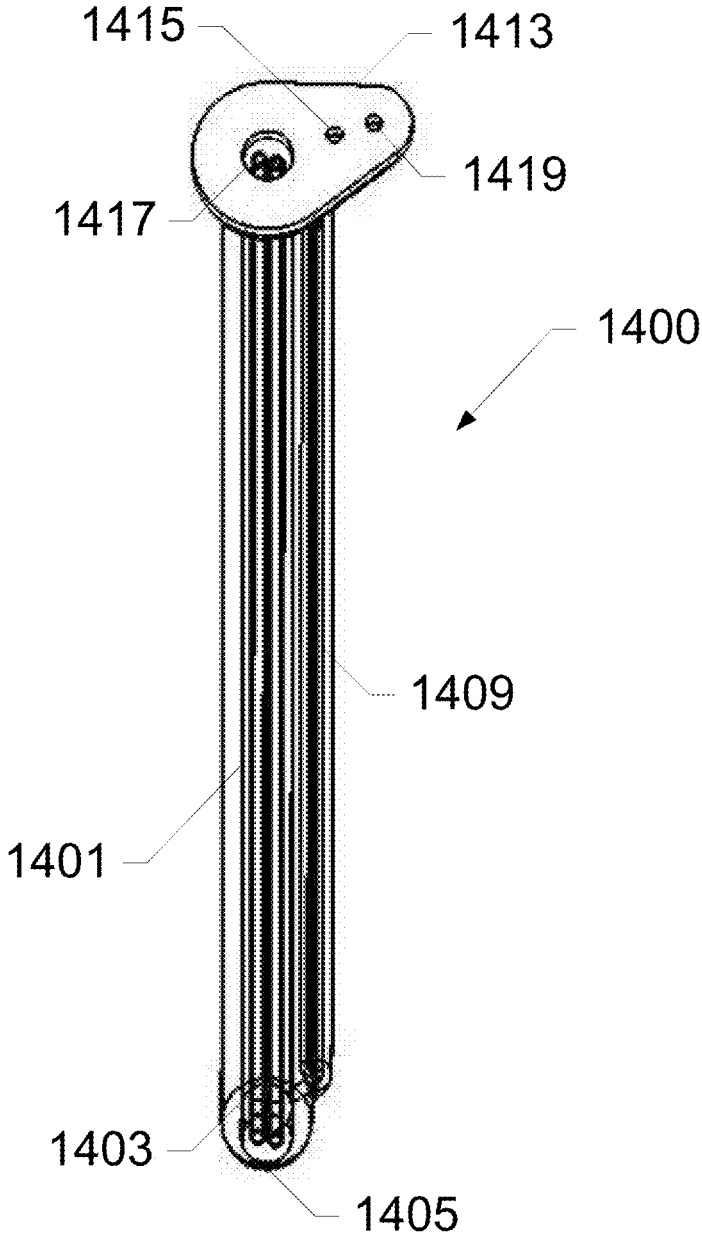

FIG. 14A

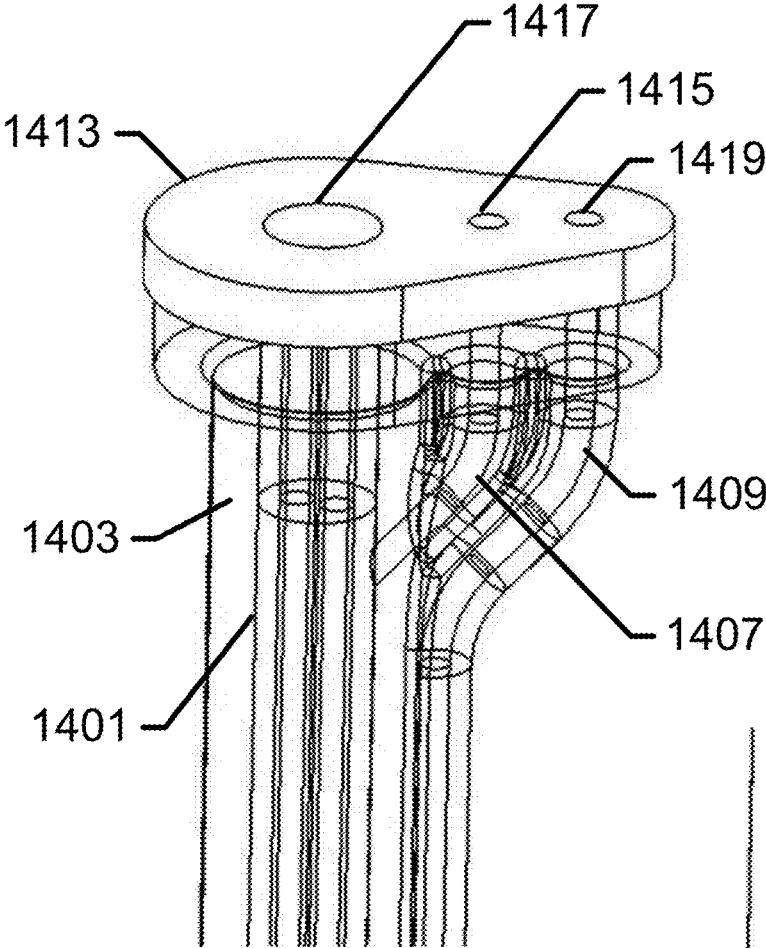

FIG. 14B

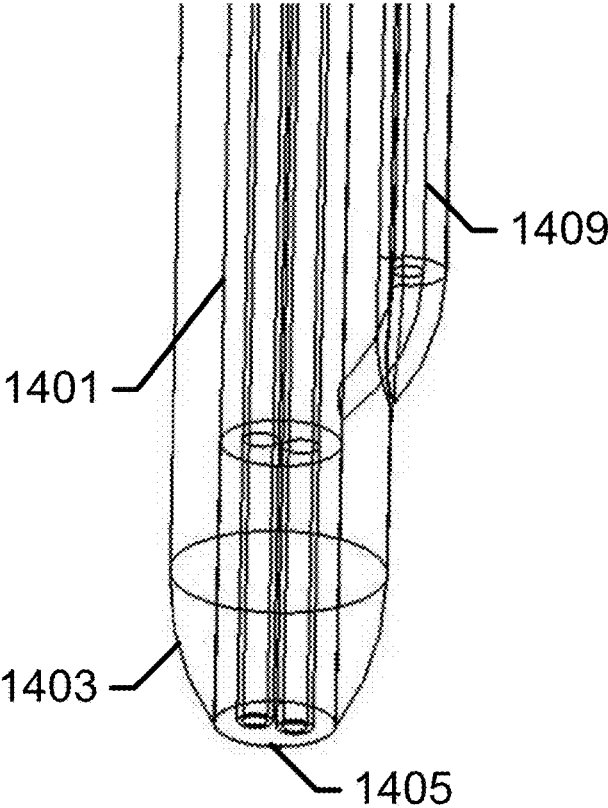

FIG. 14C

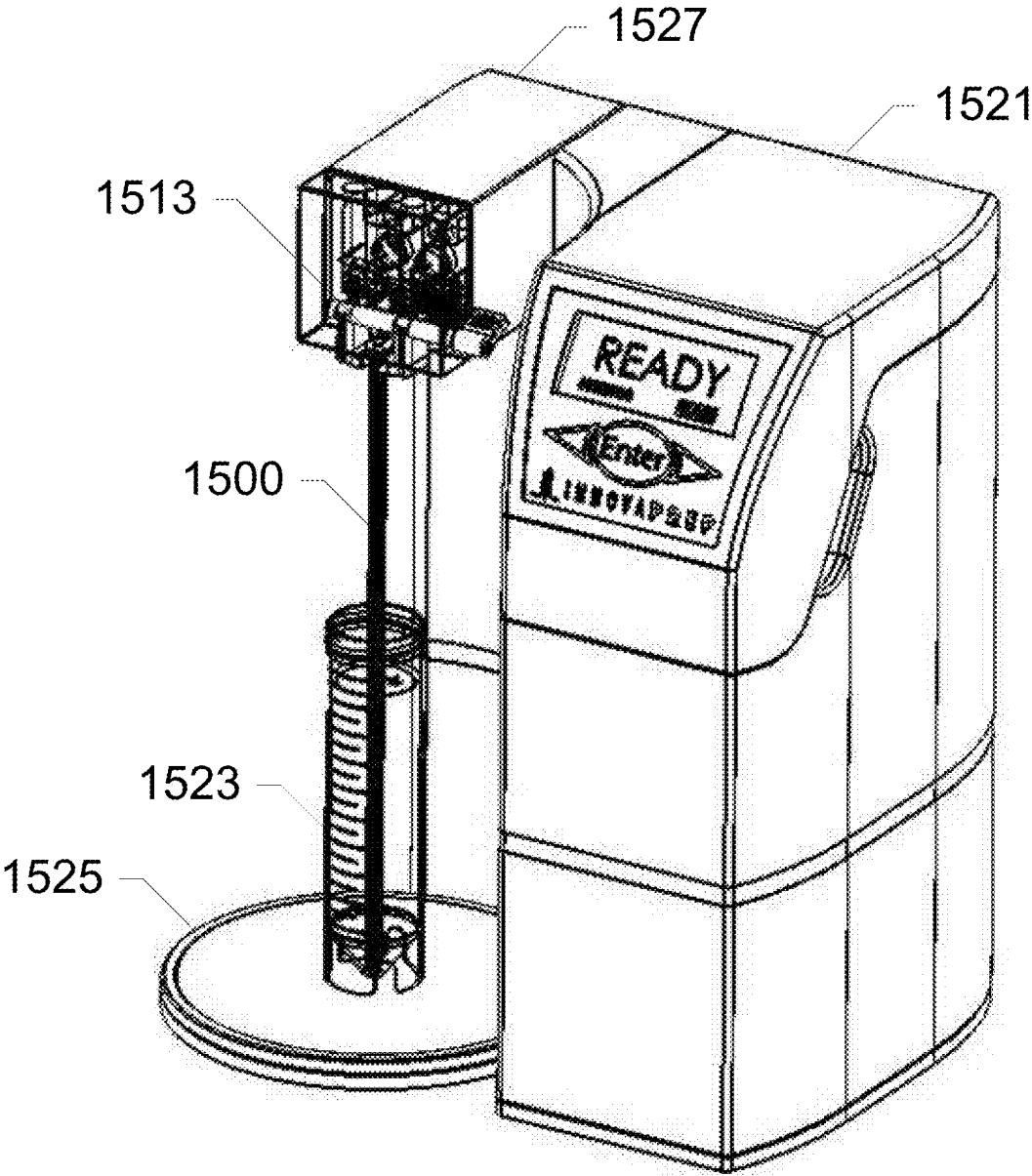

FIG. 15

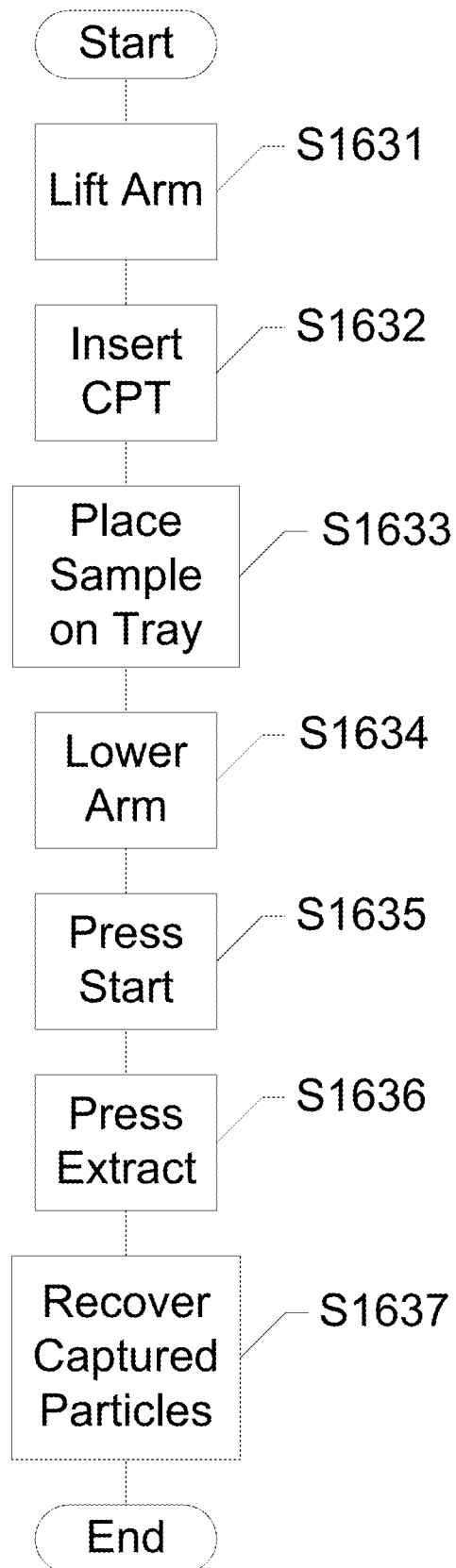

FIG. 16

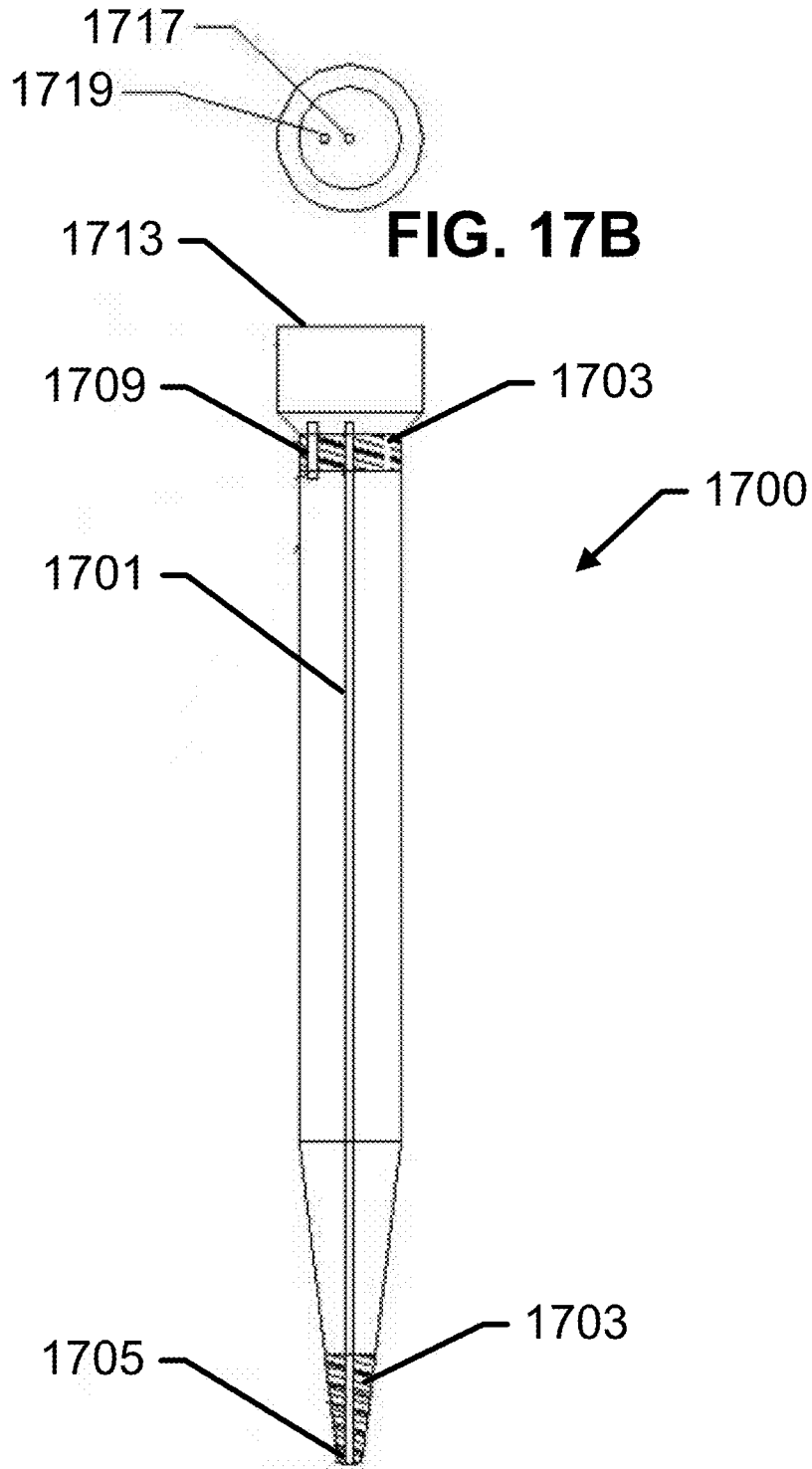

FIG. 17B

FIG. 17A

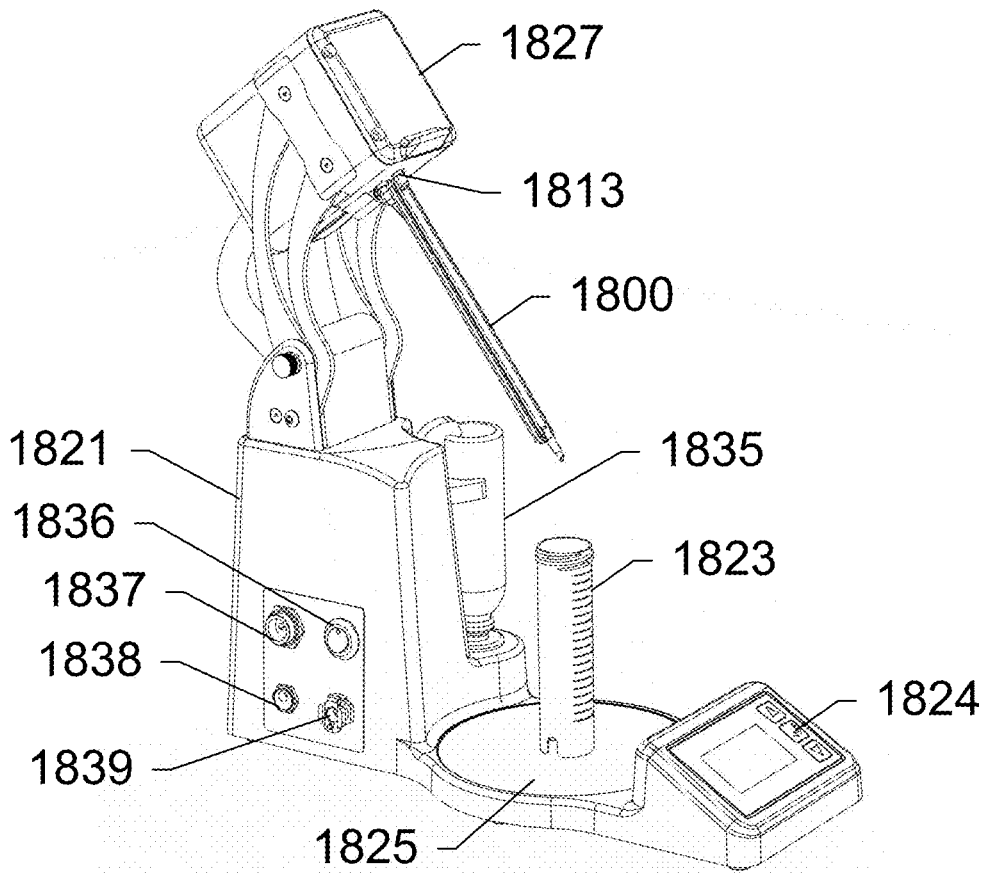

FIG. 18A

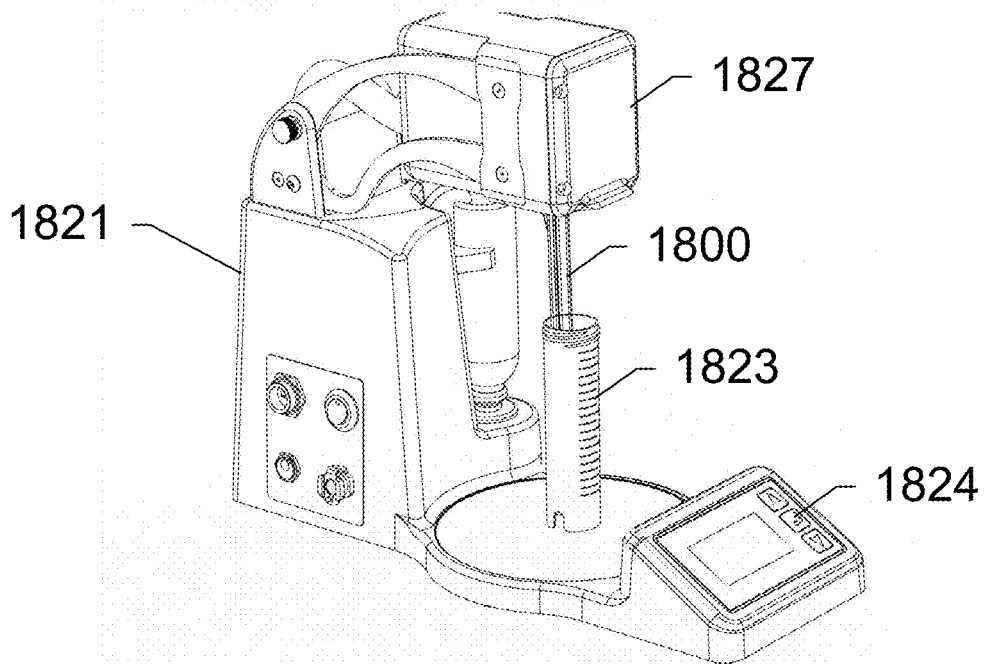

FIG. 18B

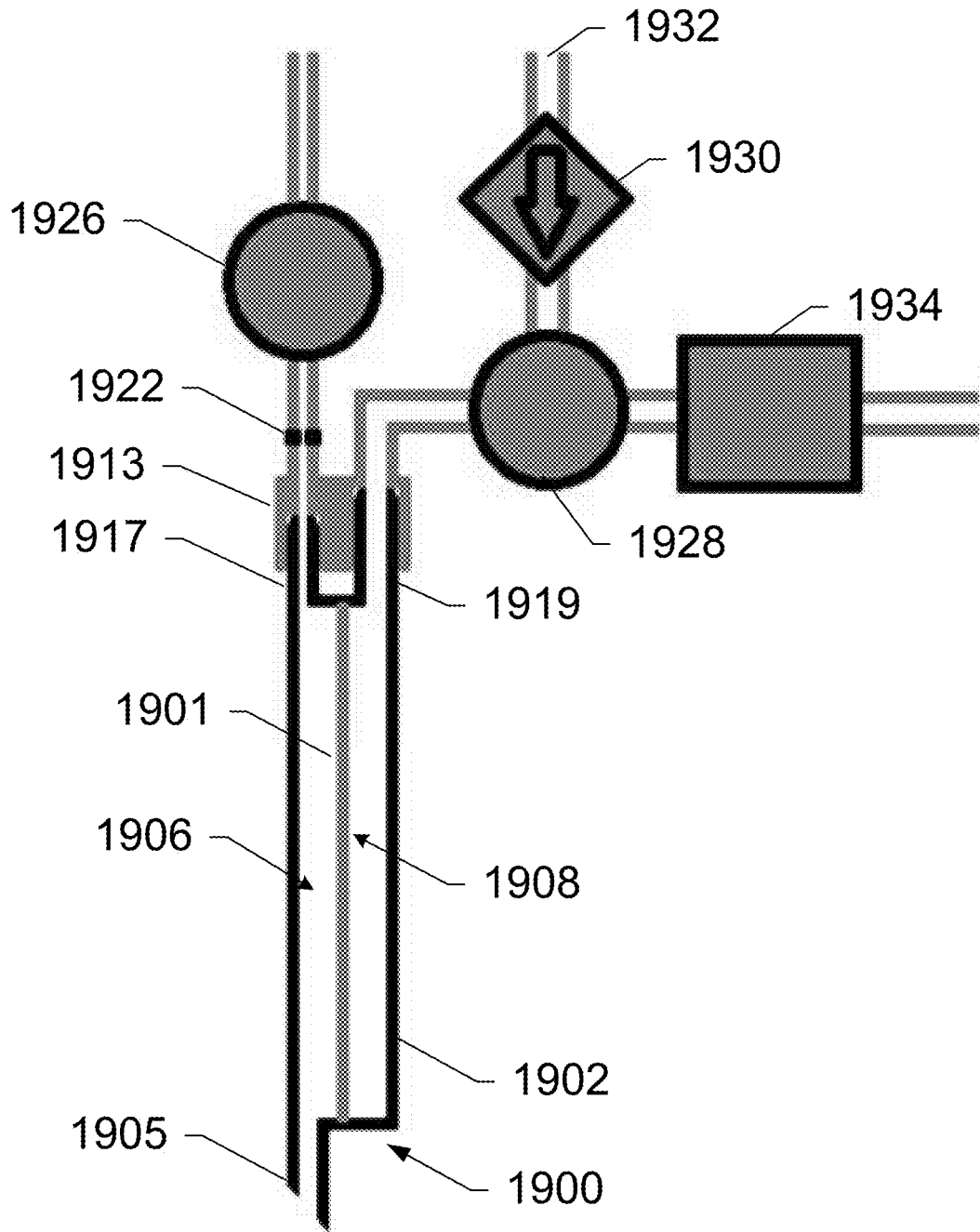

FIG. 19

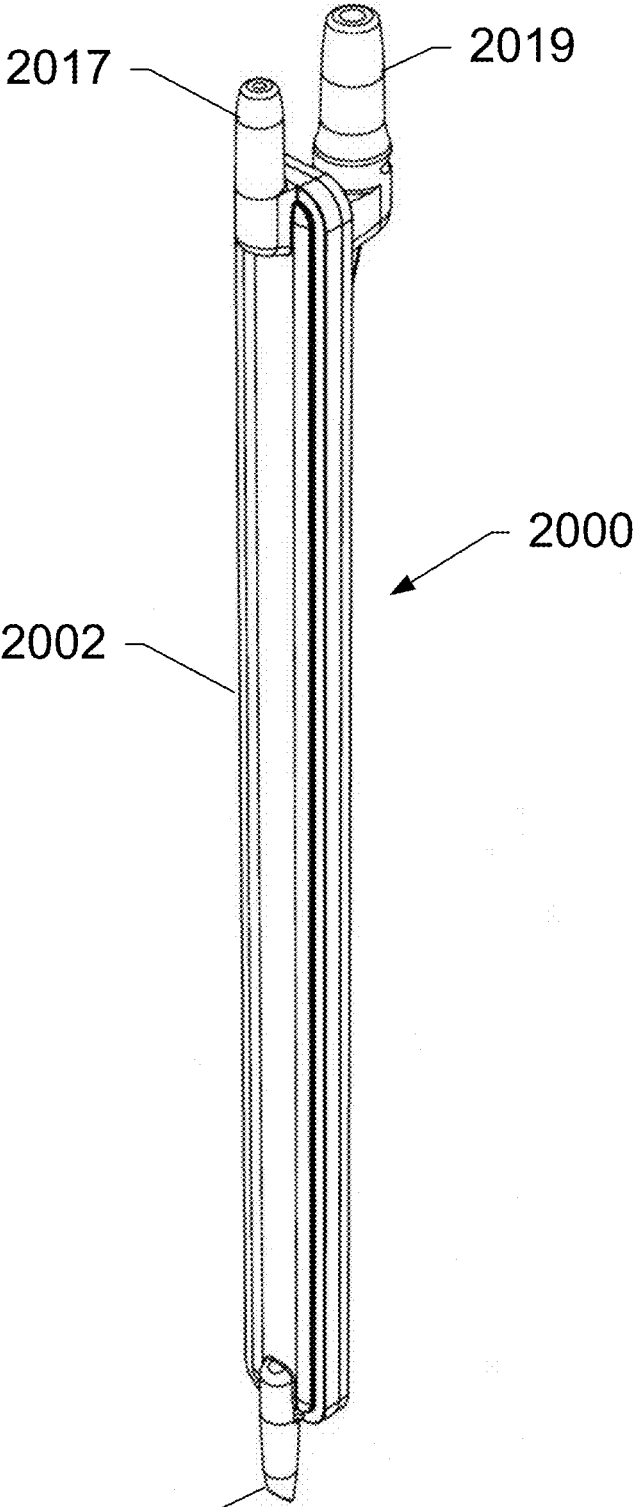

FIG. 20

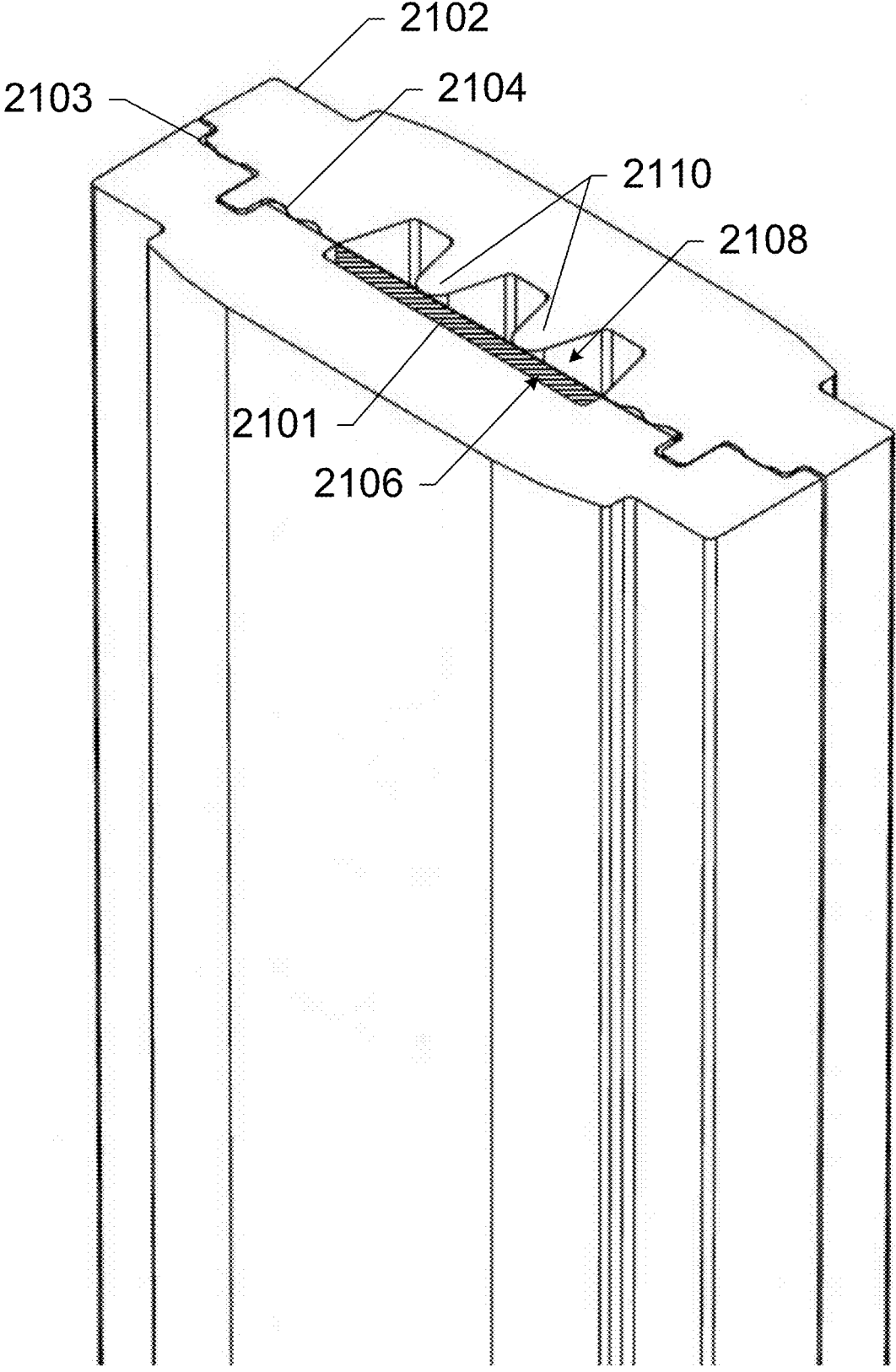

FIG. 21

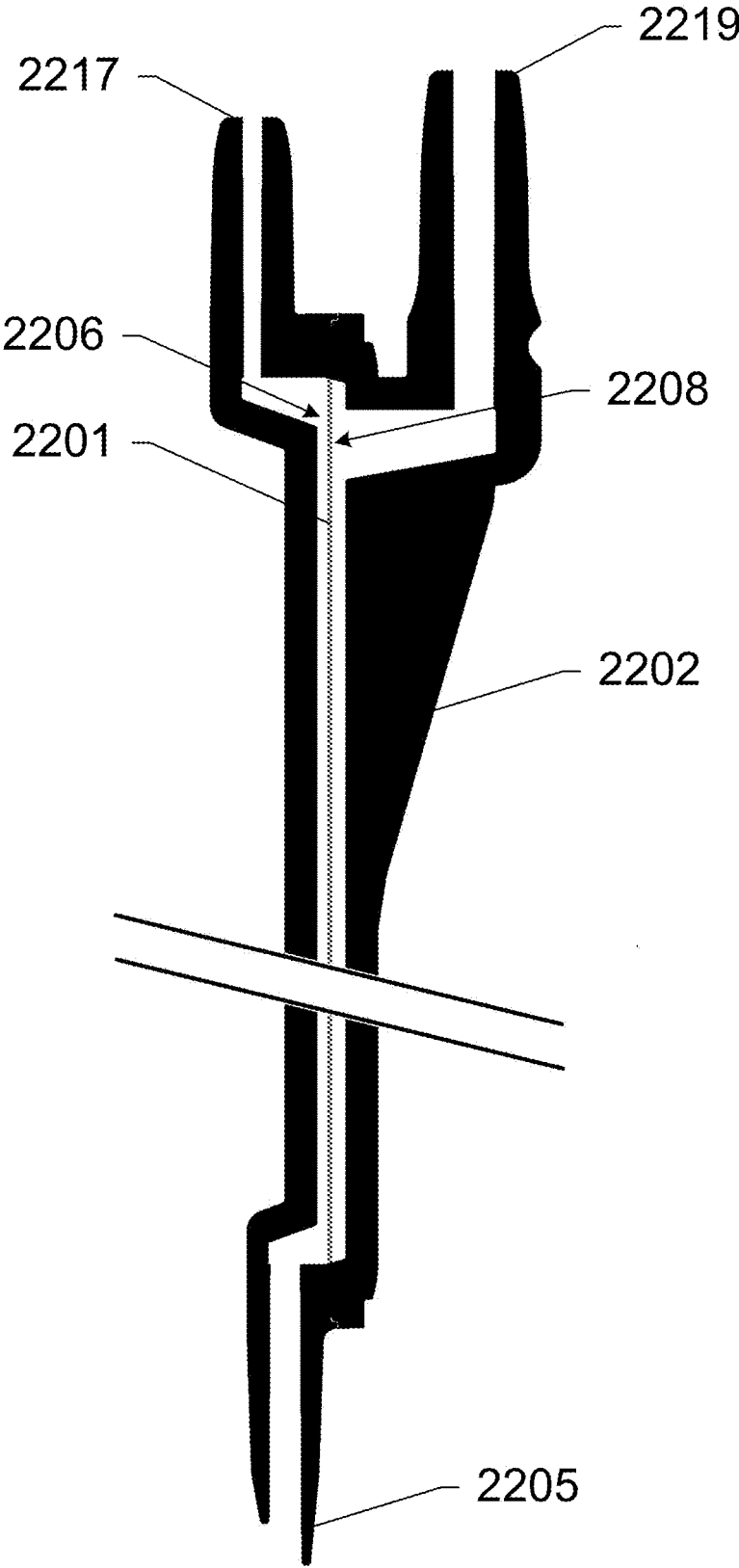

FIG. 22

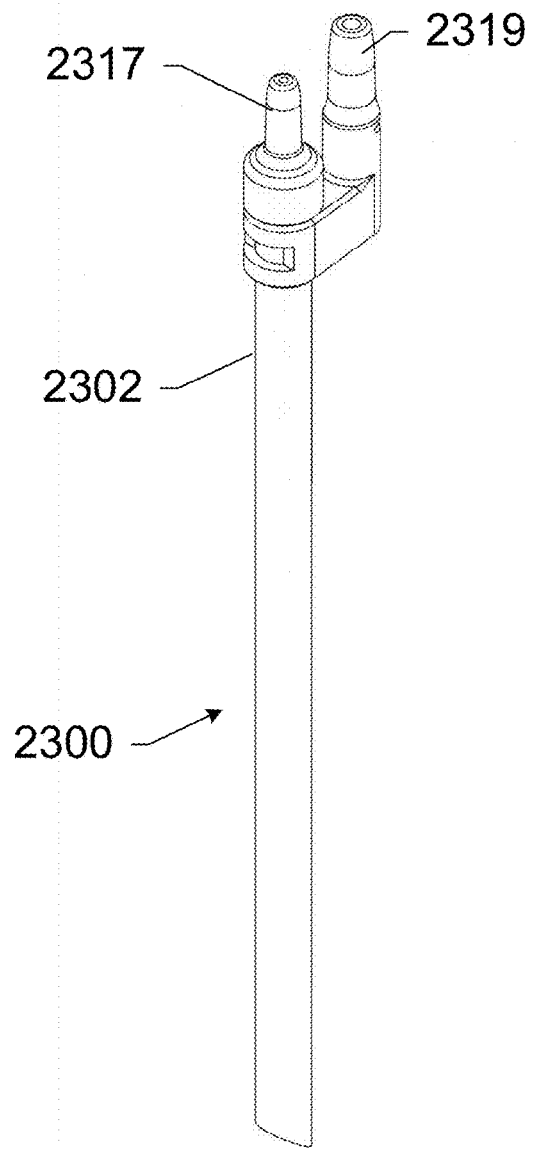

FIG. 23A

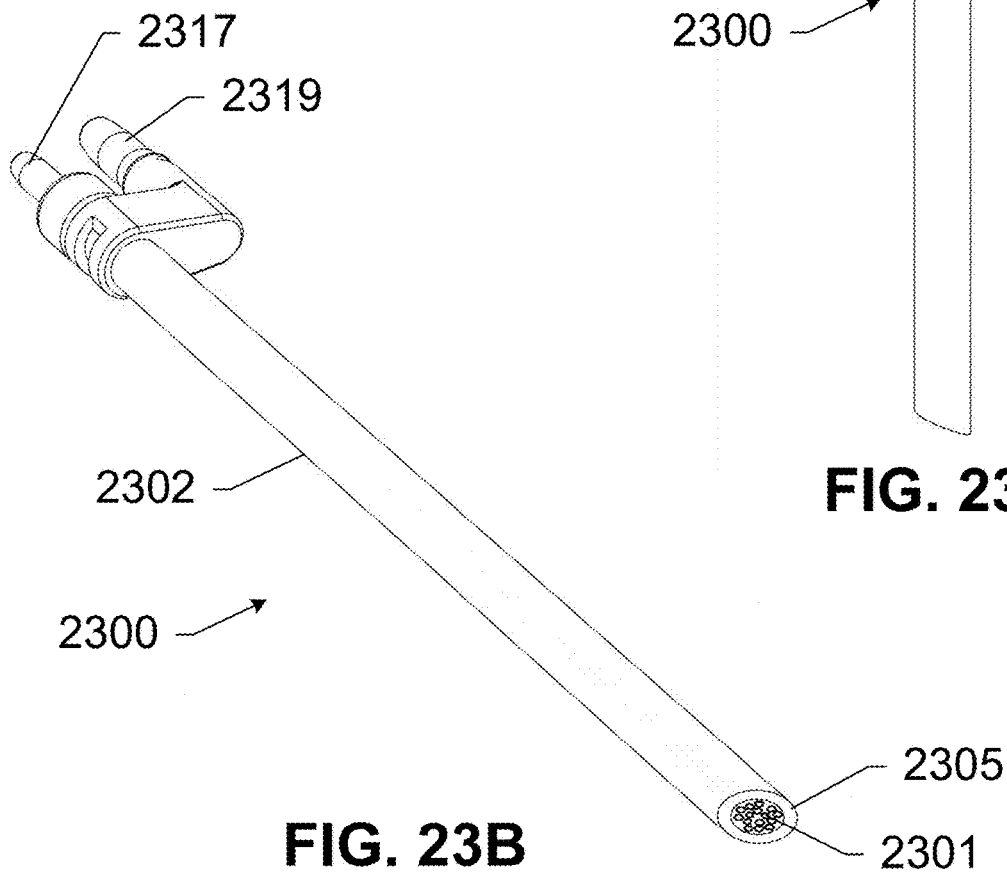

FIG. 23B

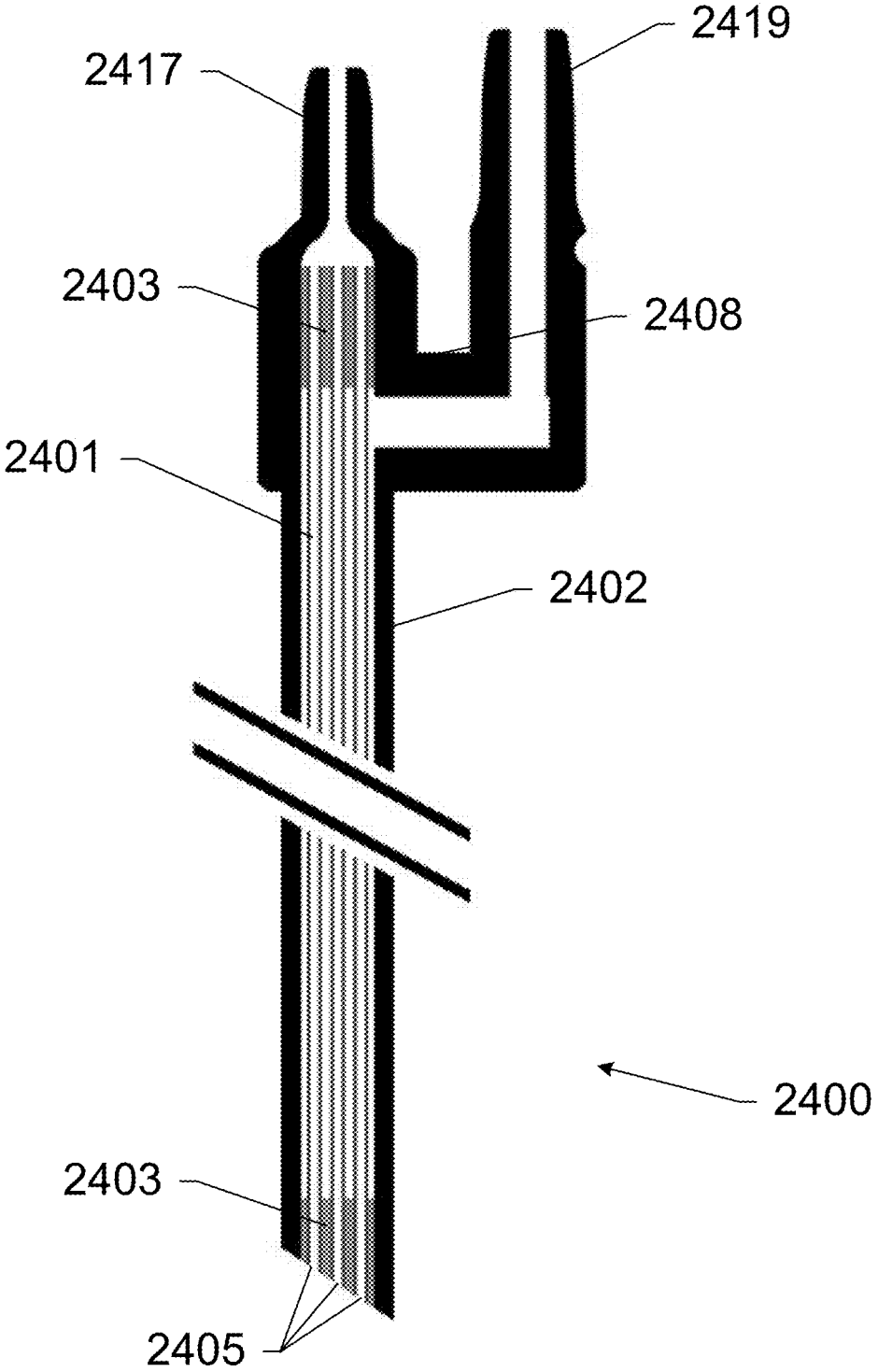

FIG. 24

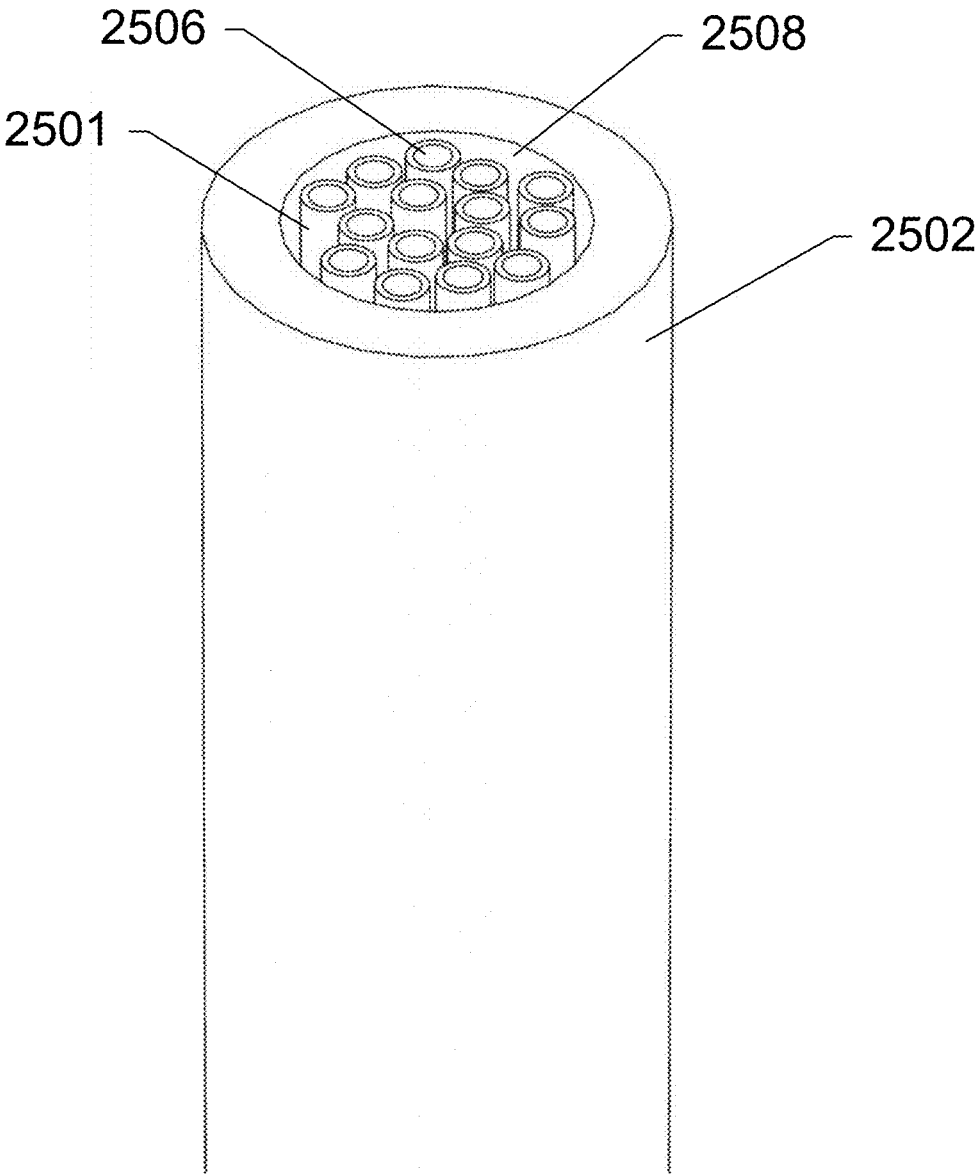

FIG. 25

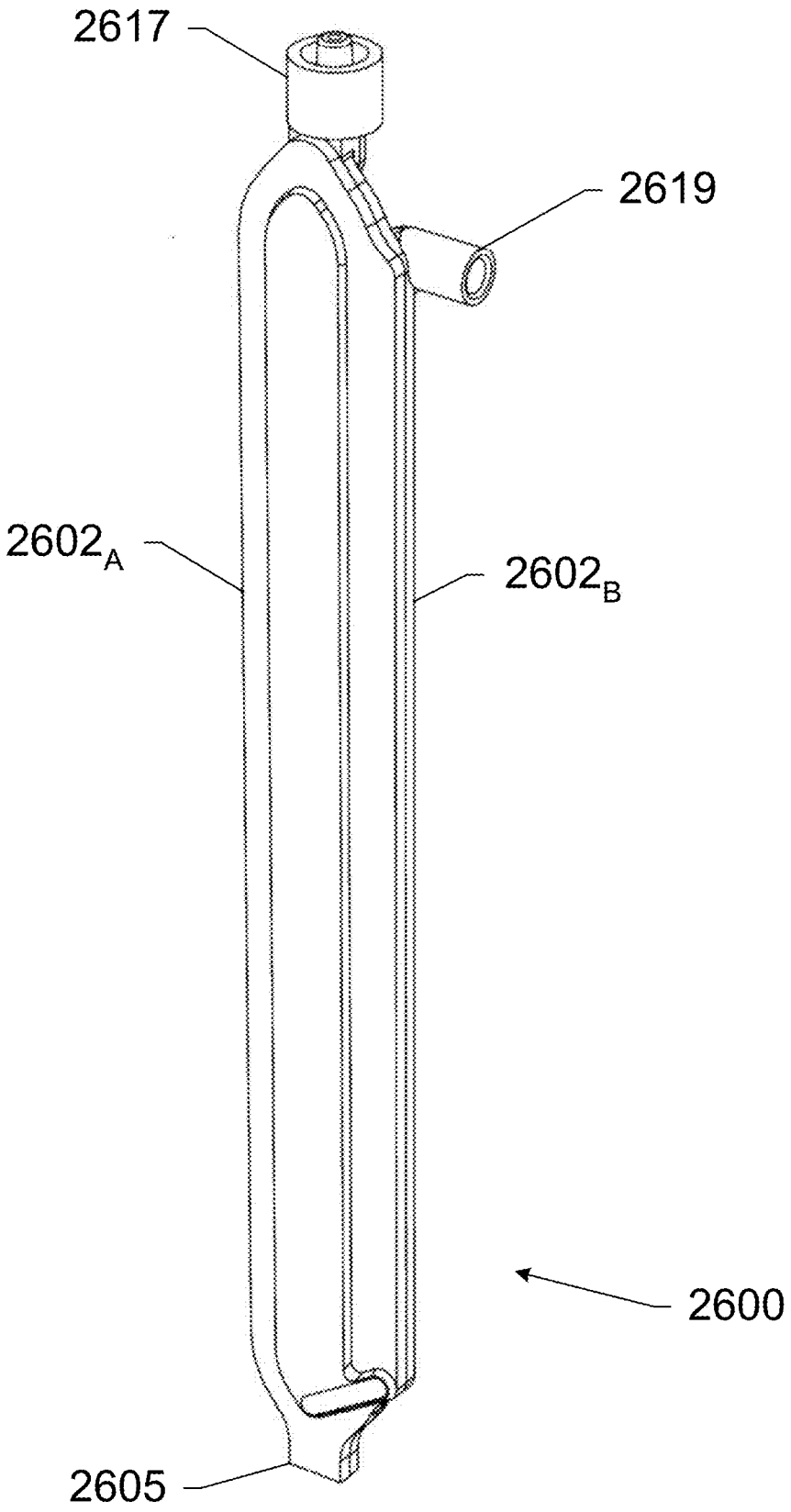

FIG. 26

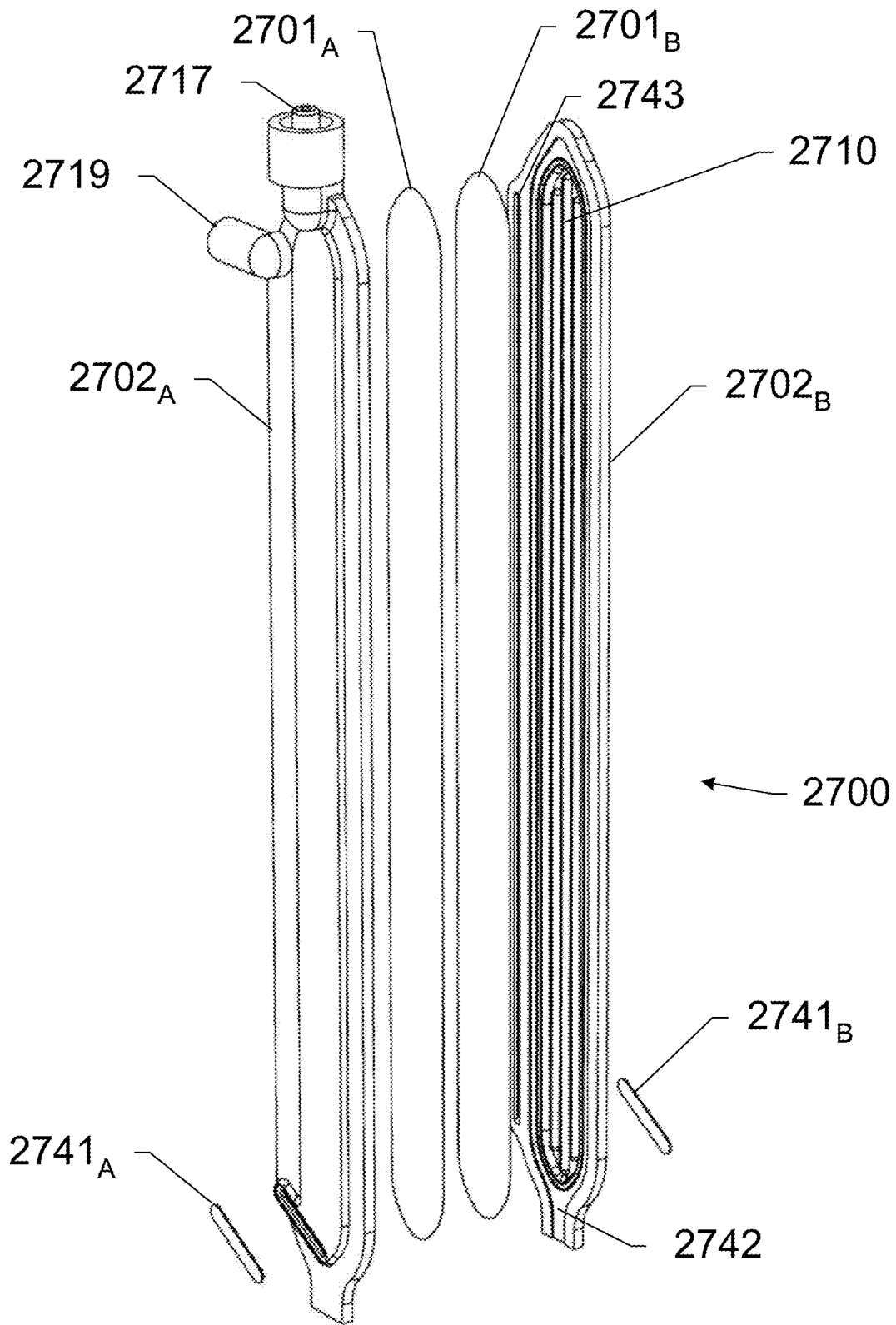

FIG. 27

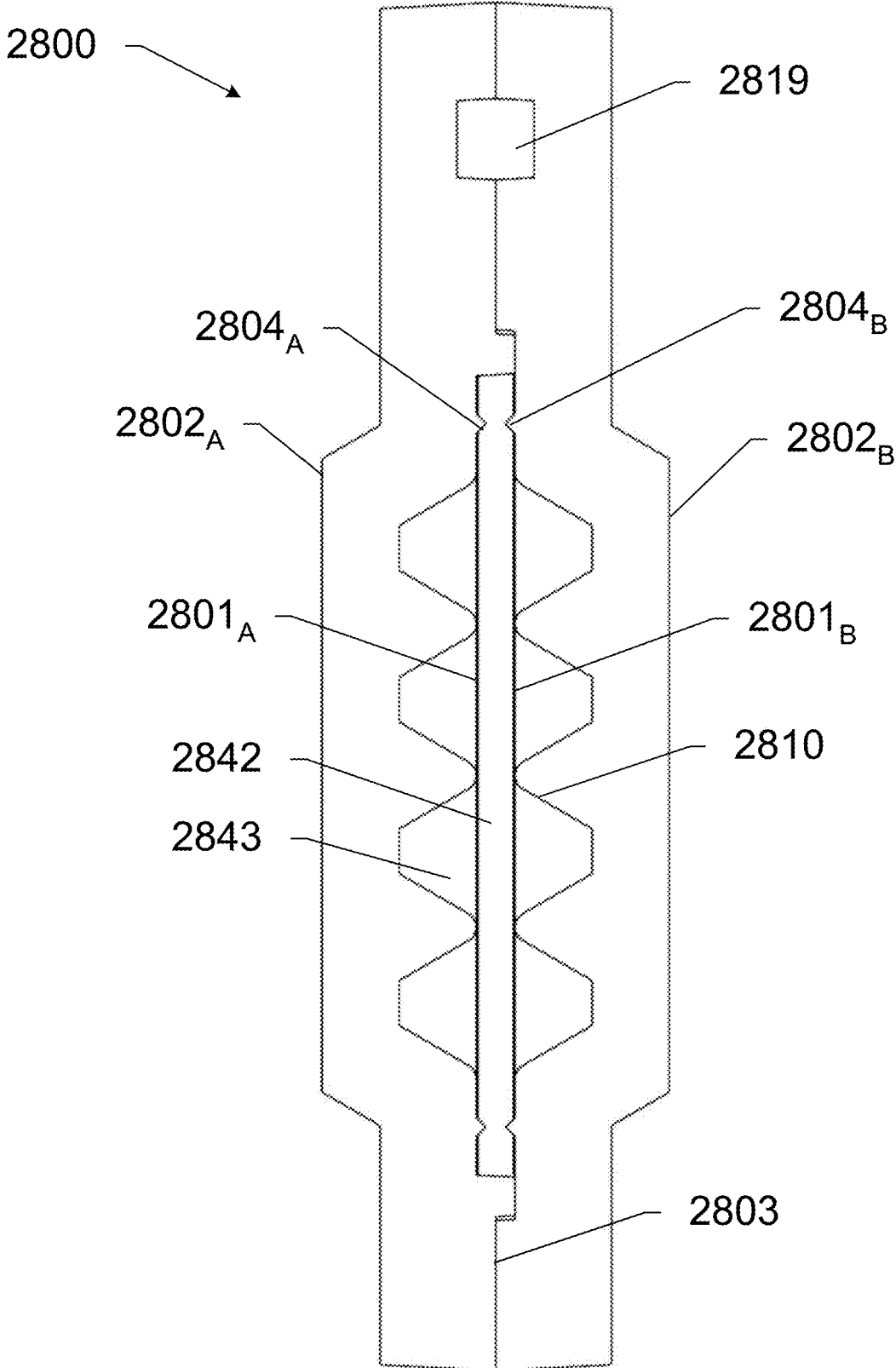

FIG. 28

**LIQUID TO LIQUID BIOLOGICAL
PARTICLE CONCENTRATOR WITH
DISPOSABLE FLUID PATH**

[0001] This U.S. Patent Application is a continuation of U.S. patent application Ser. No. 15/431,655, filed Feb. 13, 2017, now U.S. Pat. No. 10,955,316; which is a continuation of U.S. patent application Ser. No. 14/191,205, filed Feb. 26, 2014, now U.S. Pat. No. 9,574,977; which claims priority to U.S. Provisional Patent Application Ser. No. 61/769,672, filed Feb. 26, 2013; further, U.S. patent application Ser. No. 14/191,205 is a continuation-in-part of U.S. patent application Ser. No. 14/084,385, filed Nov. 19, 2013, now U.S. Pat. No. 9,593,359; which claims priority to U.S. patent application Ser. No. 12/882,188, filed Sep. 14, 2010, now U.S. Pat. No. 8,584,535; which claims priority to U.S. Provisional Patent Application Ser. No. 61/276,737, filed Sep. 17, 2009; the contents of all of which are hereby incorporated by reference herein in their entirety into this disclosure.

**BACKGROUND OF THE SUBJECT
DISCLOSURE**

Field of the Subject Disclosure

[0002] The subject disclosure relates generally to the field of sample preparation. More particularly, the subject disclosure relates to a method and device for automated concentration of particles for enhancing the sensitivity of subsequent analysis methods.

Background of the Subject Disclosure

[0003] The difficulties of detecting and quantifying dilute materials in liquids are well known. Existing systems all begin to fail as analyte concentrations decrease, eventually leading to a non-detect of the analyte at very low concentrations. This poses a significant problem to national security, for example, the postal anthrax attacks of 2001 and the subsequent war on terrorism have revealed shortcomings in the sampling and detection of biothreats. The medical arts are similarly affected by the existing limits of detection, as are the environmental sciences.

[0004] The detection limits of existing analytical systems that quantitate particles in solution do not disqualify their use in studying analytes or particles that fall below these limits. Rather, methods are needed for concentration of the particles prior to analysis.

[0005] Particle concentration in liquid is traditionally performed using centrifugation. Centrifugal force is used for the separation of mixtures according to differences in the density of the individual components present in the mixture. This force separates a mixture forming a pellet of relatively dense material at the bottom of the tube. The remaining solution, referred to as the supernate or supernatant liquid, may then be carefully decanted from the tube without disturbing the pellet, or withdrawn using a Pasteur pipette. The rate of centrifugation is specified by the acceleration applied to the sample, and is typically measured in revolutions per minute (RPM) or g-forces. The particle settling velocity in centrifugation is a function of the particle's size and shape, centrifugal acceleration, the volume fraction of solids present, the density difference between the particle and the liquid, and viscosity of the liquid.

[0006] Problems with the centrifugation technique limit its applicability. The settling velocity of particles in the micron

size range is quite low and, consequently, centrifugal concentration of these particles takes several minutes to many hours. The actual time varies depending on the volume of the sample, the equipment used, and the skill of the operator. The nature of centrifugation techniques and of the devices used to perform centrifugation requires a skilled operator, thus making automation and integration into other systems difficult.

[0007] Centrifugation techniques are tedious in that they are normally made up of multiple steps each requiring a high level of concentration from the operator. It is common in most microbiology laboratories to process large numbers of samples by centrifugation on a daily basis. The potential for human error is high due to the tedious nature; and as stated earlier automation of these techniques is difficult and costly.

[0008] Other concentration techniques have been explored and primarily fall into three technology groups—microfluidic/electrophoretic based, filtration based, and capture based. Each of these techniques has advantages and disadvantages.

[0009] Traditional flat filtration methodology is used to capture particles from a liquid onto a flat filter, usually supported by a screen or fritted substrate. Many different methods of filtration exist, but all aim to attain the separation of two or more substances. This is achieved by some form of interaction between the substance or objects to be removed and the filter. The substance that is to pass through the filter must be a fluid, i.e. a liquid or gas. The simplest method of filtration is to pass a solution of a solid and fluid through a porous interface so that the solid is trapped, while the fluid passes through. This principle relies upon the size difference between the particles contained in the fluid, and the particles making up the solid. In the laboratory, this is often done using a Büchner funnel with a filter paper that serves as the porous barrier.

[0010] One disadvantage of the physical barrier method of filtration is that the substance being filtered from the fluid will clog the channels through the filter over time. The resistance to flow through the filter becomes greater and greater over time as, for example, a vacuum cleaner bag. Accordingly, methods have been developed to prevent this from happening. Most such methods involve replacing the filter; however, if the filter is needed for a continuous process this need for replacement is highly problematic. Scraping and in-situ cleaning mechanisms may be used, but these can be unnecessarily complex and expensive.

[0011] In one example, bacteria may be removed from water by passing them through a filter supported in a Buchner funnel to trap the bacteria on the flat filter. Aerosol particles containing biological materials can also be trapped in the same way. For analysis, the trapped materials are often re-suspended in a known volume of liquid. This allows back-calculation of the original aerosol concentration. One method validated by the Edgewood Chemical Biological Center uses 47 mm glass-fiber filters to capture reference samples for biological analysis. The bacteria are extracted by soaking the filters overnight in 20 mL of buffered saline solution, then vortexed for 3 minutes to disrupt the filter material completely. Subsamples or aliquots of these suspensions are then provided for analysis by viable culture, PCR, or other methods.

[0012] Other technologies for concentration of biological particulate matter exist. Sandia National Laboratories, Massachusetts Institute of Technology, and other organizations

have developed microfluidic devices that separate and concentrate particles by dielectrophoresis or electrophoresis. These units use microchannels and electric fields to move or collect particles. Sandia has also developed a system that concentrates particles at the interface between two immiscible liquids. Immunomagnetic particles are commercially available for use in the separation and concentration of bacteria.

[0013] Various methods exist for concentrating organisms in liquids prior to detection. Historically, the most common method is to enrich the sample in nutrient broth and then cultivate an aliquot of the broth on an agar plate. The biggest disadvantage of this method is the time requirement. It normally takes five to seven days before organisms can be enumerated on the plates. Other concentration methods include various filtration based methods, adsorption-elution, immunocapture, flocculation, and centrifugation. It is problematic that to date no automated methods have been developed that can rapidly concentrate a large volume of water into a very small sample volume and do this task efficiently. In fact most of these methods fail in each of these areas, most notably efficiency of concentration, and ease of use.

[0014] A considerable amount of research has been performed using hollow fiber ultrafiltration to concentrate bacteria, viruses, and protozoa from large volumes of water. Most of the methods described are not automated. Generally these systems are capable of concentrating 10 to 100 L water into 100 to 500 mL of concentrated sample; however, it is further problematic that none of the demonstrated technologies provides concentration into volumes of less than 100 mL. Even this volume is much larger than desired for the best possible detection when the concentrator systems are coupled with downstream detection apparatus. This means that a costly and time-consuming second manual concentration step is required to bring the final sample to the desired volume.

[0015] The alternative concentration systems described above, although automated, do not provide significant advantages over traditional centrifugation for many laboratories, including microbiology, biotechnology, and clinical biology laboratories. These laboratories require a high level of certainty that sample to sample contamination does not take place. The alternative, automated concentration systems, have significant fluidics that samples are exposed to and in many cases it is, at best, costly and, at worst, impossible to replace these fluidics lines between samples.

[0016] The potential for carryover of particles of interest or signatures from one sample to another and the potential for growth of bacteria within the system fluidics significantly limit their applicability to clinical laboratories. In general, microbiology and biotechnology laboratories have adopted the use of disposable components in nearly all work.

[0017] A concentration system with a disposable fluid path that is capable of concentrating biological materials from relatively large volumes of liquids would have significant applicability to clinical diagnostics and microbiology and biotechnology laboratories. Spin columns that contain an ultrafilter or microfilter type membrane filters and can be placed into a centrifuge or in some instances use positive pressure to drive the liquid through are a relatively new device that is now seeing wide spread use in these laboratories.

[0018] These centrifugal spin columns overcome the contamination issues associated with other concentration systems and also overcome many of the issues associated with using centrifugation to concentration biological materials; however, the spin columns are costly, due to their complexity, and still require significant manual manipulation and pipetting during operation. A fairly high skill level is also required for their use.

SUMMARY OF THE SUBJECT DISCLOSURE

[0019] The present disclosure addresses the problem outlined and advances the art by providing a highly efficient filtration-based concentration system with sample fluidic lines and filter packaged in a disposable tip. All conduits by which the disposable tip attaches to the instrument are combined into a single connection point on the upper end of the tip. Further, a tapered tip at the lower end of the tip enables connection to pre-filters and/or additional tubing. To operate the system a new, clean tip is attached to the concentrator unit and the lower opening is dipped into a liquid sample contained in an appropriate sample container and the unit is activated. The sample is then aspirated into the tip where it comes into contact with the filter. The liquid is passed through while particles and molecules larger than the filter pore size are captured and retained. When the entire sample has been processed, the lower opening of the tip is placed into an appropriate sample container and an elution fluid or foam is used to elute the captured material and dispense it in a reduced volume.

[0020] Prior to dispensing the concentrated sample, it is also possible to perform wash steps, labeling steps, cell lysis, or other manipulation by pushing or aspirating a small volume of fluid into the fiber lumen drawing it out through the filter wall or leaving it in the fiber lumen for a period of time prior to drawing it out.

[0021] In one exemplary embodiment, the present subject disclosure is a device including a filter enclosed within a housing, the housing comprising an opening for aspirating a fluid sample positioned at its bottom end and an elution port positioned at its top end, the filter positioned in a vertical orientation and spanning a length of the housing from the top end to the bottom end, wherein a plurality of particles in the fluid sample are eluted from the a retentate surface of the filter and dispensed in a reduced fluid volume through the opening. The device further includes a connecting portion for connecting the elution port to a concentrating unit.

[0022] In another exemplary embodiment, the present subject disclosure is a device including a first half of a housing coupled to a first filter, the first filter being vertically oriented and spanning a length of the first half of the housing, and a second half of a housing coupled to a second filter, the second filter being vertically oriented and spanning a length of the second half of the housing, wherein the first and second halves of the housing are sandwiched together to form a concentrating pipette tip, and wherein a plurality of particles in a fluid sample are eluted from a retentate surface of the first and second filters and dispensed in a reduced fluid volume through an opening positioned adjacent a bottom end of the housing.

[0023] In yet another exemplary embodiment, the present subject disclosure is a device including a housing, a filter enclosed within the housing, the filter being vertically oriented and spanning a length of the housing, an opening positioned adjacent a bottom end of the housing for aspi-

rating a fluid sample, an elution port positioned adjacent a top end of the housing for receiving an elution fluid, and a permeate draw positioned adjacent the top end of the housing, the permeate draw for coupling the housing to a vacuum source, wherein a plurality of particles in the fluid sample are tangentially eluted from a retentate surface of the filter and dispensed through the opening.

BRIEF DESCRIPTION OF THE DRAWINGS

[0024] FIGS. 1A and 1B show a concentrating pipette tip (CPT), according to an exemplary embodiment of the present subject disclosure.

[0025] FIGS. 2A and 2B show a similar configuration for a hollow fiber filter that will not allow air to pass through, according to an exemplary embodiment of the present subject disclosure.

[0026] FIG. 3 shows an alternative configuration for connection of a concentrating pipette tip (CPT) to the concentrator unit, according to an exemplary embodiment of the present subject disclosure.

[0027] FIG. 4 shows a CPT including an annular configuration for connection to the concentrating unit, according to an exemplary embodiment of the present subject disclosure.

[0028] FIG. 5 shows a CPT having pin type connectors, according to an exemplary embodiment of the present subject disclosure.

[0029] FIG. 6 shows a CPT including a primary male connector, according to an exemplary embodiment of the present subject disclosure.

[0030] FIG. 7 shows a CPT including a primary male connector, according to an exemplary embodiment of the present subject disclosure.

[0031] FIG. 8 shows a CPT including a primary male connector, according to an exemplary embodiment of the present subject disclosure.

[0032] FIGS. 9-11 show one configuration for a CPT, according to an exemplary embodiment of the present subject disclosure.

[0033] FIG. 12 shows another potential configuration for a CPT, according to an exemplary embodiment of the present subject disclosure.

[0034] FIG. 13 shows a configuration for a CPT with a flat porous surface dividing the tip into an upper portion and a lower portion with an opening at the lower end and a connector at the upper end, according to an exemplary embodiment of the present subject disclosure.

[0035] FIGS. 14A-C show another configuration for a CPT, according to an exemplary embodiment of the present subject disclosure.

[0036] FIG. 15 shows a concentrating unit gathering a sample through a CPT, according to an exemplary embodiment of the present subject disclosure.

[0037] FIG. 16 shows a method of using a concentrating unit having a CPT, according to an exemplary embodiment of the present subject disclosure.

[0038] FIGS. 17A and 17B show an alternate configuration for a CPT, according to an exemplary embodiment of the present subject disclosure.

[0039] FIGS. 18A and 18B show another concentrating unit for gathering a sample through a CPT, according to an exemplary embodiment of the present subject disclosure.

[0040] FIG. 19 shows a system for gathering a sample through a CPT, according to an exemplary embodiment of the present subject disclosure.

[0041] FIG. 20 shows an external view of a CPT having a flat filter, according to an exemplary embodiment of the present subject disclosure.

[0042] FIG. 21 shows a horizontal cross section of a CPT having a flat filter, according to an exemplary embodiment of the present subject disclosure.

[0043] FIG. 22 shows a vertical cross section of a CPT having a flat filter, according to an exemplary embodiment of the present subject disclosure.

[0044] FIGS. 23A and 23B show views of a CPT having a hollow fiber filter, according to an exemplary embodiment of the present subject disclosure.

[0045] FIG. 24 shows a vertical cross section of a CPT having a hollow fiber filter, according to an exemplary embodiment of the present subject disclosure.

[0046] FIG. 25 shows a horizontal cross section of a CPT having a hollow fiber filter, according to an exemplary embodiment of the present subject disclosure.

[0047] FIG. 26 shows an isometric view of a CPT having two filters, according to an exemplary embodiment of the present subject disclosure.

[0048] FIG. 27 shows an exploded view of a CPT having two filters, according to an exemplary embodiment of the present subject disclosure.

[0049] FIG. 28 shows a cross-sectional view of a CPT having two filters, according to an exemplary embodiment of the present subject disclosure.

DETAILED DESCRIPTION OF THE SUBJECT DISCLOSURE

[0050] The present subject disclosure is a highly efficient filtration-based concentration system with sample fluidic lines and a filter packaged in a disposable concentrating pipette tip. All conduits by which the disposable concentrating pipette tip attaches to the concentrator unit instrument are combined into a single connection point on the upper end of the concentrating pipette tip. The concentrating pipette tip (CPT) works with a system including a concentrator unit and a liquid sample. To operate the system, a new clean concentrating pipette tip is attached to the concentrator unit and the lower opening of the concentrating pipette tip is dipped into a liquid sample contained in an appropriate sample container and the concentrator unit is activated. The use of a new clean concentrating pipette tip ensures that there is no sample-to-sample carryover. The sample is then aspirated into the CPT where it comes into contact with a filter. The liquid is passed through the filter while particles and molecules larger than the filter pore size are captured and retained. When the entire sample has passed through the filter, removing the fluid and leaving the captured material, the lower opening of the tip is placed into an appropriate sample container and an elution fluid or foam is used to elute the captured material and dispense it in a reduced volume.

[0051] Prior to dispensing the concentrated sample, it is also possible to perform wash steps, labeling steps, cell lysis, or other manipulation by pushing a small volume of fluid into the fiber lumen drawing it out through the filter wall or leaving it in the fiber lumen for a period of time prior to drawing it out.

[0052] After being dispensed, the concentrated sample may be further concentrated prior to analysis by immunomagnetic separation, electrophoretic or dielectrophoretic separation techniques, or other microfluidic concentration techniques. In many instances these techniques are useful

but are in general not possible with larger volumes or are prohibitively costly or slow when performed on large volumes. By rapidly performing an initial concentration with the CPT the sample volume is reduced to a volume that is more readily handled with these techniques.

[0053] It is further possible to apply additional sample preparation techniques to the concentrated sample once dispensed. Additional sample preparation techniques that may be applied include various methods of cell lysis, washing steps, inhibitor or interferent removal techniques, and labeling steps. Reduction of the sample volume prior to performing these techniques routinely improves the speed and efficiency, while reducing the cost of performing these techniques.

[0054] Analysis of the concentrated sample may be performed with any number of commonly used traditional analytical or microbiological analysis methods or rapid analysis techniques including rapid microbiological techniques. Analytical techniques of special interest include conventional methods of plating and enumeration, most probable number, immunoassay methods, polymerase chain reaction (PCR), electrochemical, microarray, flow cytometry, biosensors, lab-on-a-chip, and rapid growth based detection technologies to name a few.

[0055] Microorganisms including pathogens and spoilage organisms may be concentrated from any number of beverages including fruit juices, vegetable juices, carbonated beverages, alcoholic beverages and from homogenates or liquid samples produced from solid foods. By concentrating large sample volumes in the range of 1 mL to 10 L or more prior to analysis it is possible to rapidly detect microorganisms at levels that were previously only detectable following lengthy culturing of a portion of the sample.

[0056] It is further possible to test samples resulting from manual swabbing of surfaces onto wetted swabs, pads, or pieces of filter material often taken for bioterrorism security monitoring. The samples are typically extracted into a volume of liquid resulting in a 2 to 20 mL volume initial sample. Samples like these may be quickly concentrated to much smaller volumes in the range of 4 to 400 μ L such that agents may more easily be detected.

[0057] In still other aspects, samples may be concentrated for water sampling in search of bioterrorism agents, or in the interest of public health and safety, especially where a sample may contain target agent(s) that are thought to be a threat to the health of humans, animals or plants, causing societal disruption and economic harm. Agricultural products and livestock environments may also be evaluated by the instrumentalities herein disclosed.

[0058] Environmental studies that may also benefit from the present subject disclosure include many types of sampling and analysis that are performed for the field of environmental study, such as in assessing health effects through research regarding various materials in inhaled particulate matter with aerodynamic diameter below 2.5 microns (PM 2.5) or high altitude aerosol research where low quantities of particulate are collected and must be concentrated for study. These instrumentalities may benefit clean rooms where very low aerosol concentrations of aerosol particles are collected for monitoring that is aimed at source control.

[0059] Forensic sciences may also benefit from the present subject disclosure by allowing for detection of DNA collected from large surfaces, articles of clothing, air samples, liquids or other forensic type samples. Touch DNA and

low-template DNA techniques can be further extended by concentrating large sample volumes into volumes more closely matching the analysis volume.

[0060] These types of sampling and analysis are advantageously performed for the fields of homeland security, corporate security, and military force protection. Additional fields of use include medical research and diagnostics. For example, sample concentration is useful in determining if catheter or other medical devices are contaminated with bacteria. These devices routinely become contaminated in the hospital setting. However it is often difficult to determine which device is causing an infection. Concentration of wash fluid from these devices allows for rapid detection of the infecting organism. Sample concentration is useful in cancer research where very low concentrations of experimental drugs in body fluids or urine are the targets of analysis, and in allergy diagnosis where low quantities of specific antigens are the targets of analysis in body fluids. Health effects research may also benefit by determining health effects known to be caused by various materials in inhaled particulate matter with aerodynamic diameter below 2.5 microns (PM 2.5). Benefit is seen in the field of forensic medicine where low concentrations of DNA, toxins, or venoms are the targets of analysis in body fluids. Other aspects of use may include the study of operating rooms for surface extraction and air monitoring of pathogens, as well as pharmaceutical manufacturing where the biological aerosol particulate matter concentration is regulated by the United States Food and Drug Administration.

[0061] For the following description, it can be assumed that most correspondingly labeled structures across the figures (e.g., **132** and **232**, etc.) possess the same characteristics and are subject to the same structure and function. If there is a difference between correspondingly labeled elements that is not pointed out, and this difference results in a non-corresponding structure or function of an element for a particular embodiment, then that conflicting description given for that particular embodiment shall govern.

[0062] In the following figures, there will be shown and described multiple configurations of disposable concentrating pipette tips which may be used to concentrate biological particles into a reduced liquid volume.

[0063] FIGS. **1A** and **1B** show a concentrating pipette tip (CPT) **100**, according to an exemplary embodiment of the present subject disclosure. FIG. **1A** shows a CPT **100** includes an opening **105**, a hollow fiber filter **101**, a permeate purge **107**, and a permeate draw **109**. CPT **100**, including opening **105**, fiber filter **101**, permeate purge **107**, and permeate draw **109** is replaced between samples, removing the potential for cross contamination within the system. Because the sample is aspirated, concentrated, and dispensed with a single instrument, work flow in the laboratory is improved and the required operator skill level is significantly reduced. Automation of the system through platforms similar to those used in automated pipetting workstations will provide a low-cost alternative to automated centrifuge systems with significantly improved operating and higher efficiencies. Multi-tip concentration systems, such as the present subject disclosure, may push the speed of these automated systems an order of magnitude higher.

[0064] CPT **100** is a disposable tip that may be constructed by plastic molding techniques. CPT **100** may be, for instance, similar in dimensions to an Eppendorf epT.I.P.s 10 mL tip. CPT **100** includes a connecting portion **113** and an

opening **105**. Connecting portion **113** allows CPT **100** to be connected to a concentrating unit for operation of CPT **100**. Within connecting portion **113**, three ports are contained. FIG. 1B shows the three ports, which include a first port **115** connected to permeate purge **107**, a second port **117** connected to fiber filter **101**, and a third port **119** connected to permeate draw **109**. When connected to the concentrator unit second port **117** is in fluidic connection with an elution fluid line originating in the concentrator unit. First port **115** is in fluidic connection with a valve contained within the concentrator unit. Third port **119** is in fluidic connection with a pump contained within the concentrator unit. Opening **105** allows CPT **100** to aspirate a sample into fiber filter **101**. Opening **105** provides a small pointed end with a single opening into the lumen of fiber filter **101**. CPT **100** also includes potting **103** to secure fiber filter **101**, permeate purge **107**, and permeate draw **109**.

[0065] In this configuration, fiber filter **101** is a single hollow fiber filter **101** allowing air to pass through (e.g. microfilter) and is secured into CPT **100** on both ends using potting **103** such that the lumen of fiber filter **101** creates opening **105**. Fiber filter **101** may be, for instance, a Spectrum Laboratories, Inc. 100 kD Polysulfone hollow fiber with an internal diameter of 0.5 mm such as those used in the Spectrum Laboratories X1AB-300-04N Module. Connecting portion **113** of fiber filter **101** along with a section of tubing for permeate purge **107** and a section of tubing for permeate draw **109** are all sealed near connecting portion **113** of CPT **100** with potting material **103**. In one aspect, fiber filter **101** is one or more hollow fiber filters contained within CPT **100** with CPT **100** being constructed of an impermeable material. Fiber filter **101** or filters and CPT **100** form a permeate chamber between the impermeable wall of CPT **100** and the hollow fiber wall of fiber filter **101**.

[0066] Hollow fiber filters, such as fiber filter **101**, and other membrane type filters are primarily broken into three groups, these are: microfiltration, ultrafiltration, and nanofiltration. Each of these groups is useful for different types of agents being removed from a sample. Nanofiltration filters are not of significant importance here and will not be discussed. Microfiltration refers to those filters with pore sizes of 0.1 micrometer or greater. Ultrafiltration refers to those filters with pore sizes of less than 0.1 micrometer and those in which the pore sizes are generally specified by molecular weight cutoff. Membrane type filters generally are also broken into those specified as hydrophilic and those specified as hydrophobic. In general hydrophobic pore sizes of less than about 0.65 micrometer will not allow aqueous samples to pass through, unless a wetting agent or solvent is used. Hydrophilic filters will readily pass water, but smaller pore sizes, once wet, will not readily allow air to pass until the filter is dried again. In general it is very difficult to dry a wet hydrophilic ultrafilter sufficiently to allow aqueous samples to pass, and additionally, drying ultrafilters can damage the filter resulting in a larger pore size.

[0067] Hollow fiber filters made of different materials are used for application specific reasons. Such fibers are commonly made of mixed cellulose esters (ME), polyethersulfone (PES), polysulfone (PS), polypropylene (PP) polyacrylonitrile (PAN), hydrophilic polydivinylidene fluoride (PVDF), and other materials such as stainless steel and ceramics. Various advantages and disadvantages accrue to

each type of filter. Some design criteria are the size of pores, biocompatibility, smoothness, fouling potential, and physical strength.

[0068] Permeate purge **107** is a tube connecting the permeate chamber formed between CPT **100** and the exterior of fiber filter **101** to a permeate valve within the concentrating unit through first port **115**. Permeate purge **107** provides a port for allowing air to flow into the permeate chamber. Allowing air into the permeate chamber is necessary so that liquid that collects in the permeate chamber during processing can be drawn out of the permeate and so that negative pressure in the permeate chamber can be quickly returned to atmospheric pressure. In an alternate embodiment the permeate purge is not in fluidic communication with the permeate valve but is rather a small open port. In this way leakage through the port is small enough to allow the permeate pump to draw sufficient vacuum to allow the sample to be processed, but is large enough so that after the sample is processed the remaining fluid can be drawn out of the permeate due to the inward leakage of air. During elution the permeate pump is also large enough to overcome the permeate purge leakage and increase the pressure in the permeate.

[0069] Permeate draw **109** provides a means for drawing the sample through fiber filter **101** and removing the permeate from the permeate chamber formed between concentrating tip **102** and the exterior of fiber filter **101**. After permeate flows through fiber filter **101** it is removed using permeate draw **109**. Permeate draw **109** extends from near the base inside concentrating tip **100** through third port **119** into a pump within the concentrating unit. Permeate is removed from this location until all of the permeate is removed.

[0070] First port **115** for permeate purge **107**, second port **117** for fiber filter **101**, and third port **119** for permeate draw **109** are each contained within connector **113** on the top end of CPT **100**. To operate, CPT **100** is attached to the concentrator unit such that first port **115**, second port **117**, and third port **119** connect with concentrator unit as described above. A fluid sample is aspirated into opening **105** and through the porous surface of fiber filter **101** using a pump contained within the concentrator unit that is connected to permeate draw **109** through third port **119**. In this embodiment fiber filter **101** or other membrane type filter is a dry hydrophilic filter, glycerin filled hydrophilic filter, or other filter type that allows air to pass initially and liquid to pass when contact is made. Thus, air is drawn into opening **105** and through the porous surface of fiber filter **101** until fluid is aspirated into opening **105** and making contact with fiber filter **101** passes through the porous surface.

[0071] When the entire sample volume has passed through opening **105**, the captured particles on fiber filter **101** are eluted by a tangential flush of fiber filter **101** with a known volume of elution buffer or wet foam. Alternatively a backflush of liquid may be used with a secondary tangential sweep with liquid, foam, or a gas. For a number of reasons the use of wet foam is preferred. Two primary reasons for the preference of foam for elution are (1) that a small volume of liquid may be used to create a large volume of foam, thus allowing for smaller elution volumes, and (2) the created foam is much more viscous than the starting surfactant solution, thus allowing for improved passage of the foam through multiple fiber filters. Immediately prior to tangential elution of the filter the valve controlling permeate purge **107**

is opened and the pump connected to permeate draw **109** is allowed to continue running so that any remaining fluid is drawn out of the permeate chamber. After the remaining fluid is drawn out the pump controlling permeate draw **109** is turned off and the valve connected to permeate purge **107** is closed. The permeate chamber may then be left at ambient pressure or pressurized to a positive pressure from 0 to 10 psi above ambient pressure. Removing any fluid remaining in the permeate chamber keeps the fluid from being pushed back into the retentate side of fiber filter **101** and pressurizing the permeate keeps wet foam or the elution fluid from passing through fiber filter **101** into the permeate during elution. As the foam proceeds through fiber filter **101**, the foam sweeps the concentrate through CPT **100** and out through opening **105**. When the foam has exited CPT **100** it quickly collapses back to a liquid, leaving a final concentrated product of a much reduced volume of liquid. This volume can be in a range of less than 5 microliters to 1 milliliter. In its simplest form, the foam may be made in a separate container, and then injected to sweep the sample from CPT **100** into a sample collection port. However, a sample loop may also be used to measure the amount of liquid used to make the foam. In addition to surfactant foams that are generated by mixing air and a surfactant solution the foam may also be generated with a carbonated surfactant solution. Following carbonation, the solution is agitated by dispensing through an orifice, frit, filter, or capillary tube. The surfactant foam extraction methods described here can also be used for extraction and cleaning of other collection surfaces in aerosol samplers and collectors. The use of foam to extract these surfaces can provide a significant increase in extraction efficiency and significant decrease in final sample volume. In a preferred embodiment the foam is produced by holding a buffered surfactant solution under a head pressure of carbon dioxide and then releasing a volume by opening a timed valve. By controlling both the carbon dioxide pressure and the time that the valve is open the volume of liquid dispensed can be tightly controlled.

[0072] For hollow fiber concentration pipette tips using ultrafiltration and microfiltration filters, as may be used for concentration of cellular components, DNA, viruses, bacteria, and other pathogens from a liquid sample, the sample is aspirated simply by drawing a negative pressure on the permeate chamber. In this case air is readily drawn through the fiber filter wall and fluid is aspirated into the lumen of the fiber filter where it then passes through the fiber filter wall.

[0073] To further improve the efficiency of the concentration pipette tip, a biocompatible surfactant such as Triton X-100 may be added to the feed at low levels, such as 0.1-0.01% by volume. This liquid is an insignificant volumetric addition, but can increase throughput efficiency from the 40% to 65% range to nearly 100%. Buffered surfactant solutions such as 25 mM tris buffered saline (TBS) or phosphate buffered saline (PBS) with 0.01 to 0.1% Triton X-100 or Tween 20 are commonly used in the collection fluids of bioaerosol samplers.

[0074] Mechanical shear such as produced by a shaker motor or ultrasonic horn is also used to improved throughput efficiency and processing speed.

[0075] Hollow fiber membrane filters used in the CPT can become blinded due to particle loads in the samples being processed. Methods of reducing blinding are well documented and include tangential flow, high-frequency backpulsing (HFB), vibration, and other mechanisms. Tangential

flow is the most commonly used, but it cannot be implemented in its standard form in the CPT. In the CPT system, HFB will be implemented using carbon dioxide from the wet foam elution system to create backpressure on the permeate side of the hollow fibers. The backpressure acts to push captured particles out of the filter pores. The backpressure step is performed in very short pulses with short periods of time between, hence the term high-frequency. In tests of seventy minutes of processing apple juice through single, 0.05 μm hollow-fiber CPT, within approximately 10 minutes after processing began the flow rate had dropped by approximately 50% from 2 mL/min to 1 mL/min. HFB was able to restore the flow rate to the initial flow rate of 2 mL/min and able to maintain a flow rate of greater than 1.3 mL/min throughout the remainder of the 70 minute run. Two short periods of time without HFB cycles resulted in a significant drop in the filter flow rate. The second of these gaps was seen at approximately the 47 minute mark and resulted in a drop in filter flow rate of approximately 50%.

[0076] Use of combined HFB and tangential flow is well known in industrial separations and provides the most stable flow rate for those systems by allowing the tangential flow to carry away particles removed by HFB. Because traditional tangential flow cannot be implemented on the CPT a novel oscillating tangential flow (OTF) method may be used. By using a metering pump fluidically connected with the inside of the concentration cell hollow fibers to rapidly move fluid up and down, a tangential flow is set up within the system without removing fluid from the hollow fiber bore. Such a flow over a vertically oriented filter results in significant improvements in filter flow rate with difficult to process samples. Using a metering pump to oscillate the fluid within the CPT rather than oscillating the hollow fibers themselves is seen as more practical implementation of this idea. Implementation of this method is expected to be straightforward and will provide improved sample processing flow rates for difficult to process matrices.

[0077] Moreover, using a vertically oriented flat or hollow membrane/filter that extends from the top end of the CPT, i.e. adjacent the connection point to the concentrator, enables particles to be recovered by the tangential flush described herein in a direction of travel from the top to the bottom. Such a tangential flow from the top end to the bottom allows for a very large membrane surface area, and enables processing large volumes quickly, while using only a very small volume of liquid (or wet foam) to be used to recover the particles due to the very small cross sectional area of the retentate. This further allows for greatly increased concentration factors and allows for use in a pipette by the unconcentrated sample being drawn in through the bottom opening and the concentrated sample being dispensed through the same opening. Existing horizontally-oriented systems that do not use the described tangential flushing require that the filtering media be fairly wide to provide a decent processing rate, resulting in smaller elution volumes, i.e. similar to the original sample volume, resulting in very small concentration factors.

[0078] Moreover, after processing a sample, the disclosed CPT need not hold the sample volume in the pipette tip. The separate permeate port through the CPT allows the sample volume processed to be governed only by the membrane surface area/membrane flow rate and a time taken to process, versus the limited volume based on the volume of the tip disclosed by the current state of the art.

[0079] FIGS. 2A and 2B show a similar configuration for a hollow fiber filter 201 that will not allow air to pass through, according to an exemplary embodiment of the present subject disclosure. FIG. 2A shows a CPT 200 including an opening 205, a fiber filter 201, a permeate purge 207, and a permeate draw 209. In this configuration fiber filter 201 has an upper hydrophobic vent portion 211 with the lower portion being hydrophilic 201. Hydrophilic filters will readily pass water, but smaller pore sizes, once wet, will not readily allow air to pass until dried again. The addition of hydrophobic vent portion 211 allows air to pass through the vent until the entire hydrophilic hollow fiber 201 has been filled with liquid sample and can thus allow it to pass through. In addition to this advantage, use of hydrophobic vent portion 211 allows air to be introduced into CPT 200 after operation is initiated without filling fiber filter 201 with air and thus stopping flow. Hydrophobic vent portion 211 allows the air to pass and liquid to be drawn into fiber filter 201 again. Connecting portion 213 allows CPT 200 to be connected to a concentrating unit for operation of CPT 200. Within connecting portion 213, three ports are contained. FIG. 2B shows the three ports, which include a first port 215 connected to permeate purge 207, a second port 217 connected to fiber filter 201, and a third port 219 connected to permeate draw 209. The remainder of CPT 200 shown in FIG. 2 is identical in configuration to that shown in FIGS. 1A and 1B. To operate, CPT 200 is attached to the concentrator unit and fluid is aspirated into inlet 205 and through the porous surface of fiber filter 201. When the entire sample volume has passed through inlet 205 the captured particles are eluted by a tangential flush of fiber filter 201 with a known volume of elution buffer or wet foam. Alternatively a backflush of liquid may be used with a secondary tangential sweep with liquid, foam, or a gas.

[0080] FIG. 3 shows an alternative configuration for connection of a concentrating pipette tip (CPT) 300 to the concentrator unit, according to an exemplary embodiment of the present subject disclosure. In this configuration annular sections within a main female connector 313 mate with the connector on the concentrator unit's male connector. The annular sections of connectors 315, 317, and 319 allow fluid flow between connectors despite the orientation. The primary advantage of the annular connectors is that CPT 300 does not have to be oriented in a specific way, and may spin or otherwise change orientation during use without disruption. In this particular CPT 300 a hydrophobic flat filter section 311 is used for venting.

[0081] FIG. 4 shows a CPT 400 including an annular configuration for connection to the concentrating unit, according to an exemplary embodiment of the present subject disclosure. In this configuration annular sections within the main female connector 413 mate with the connector on the concentrator unit's male connector. The annular sections of connectors 415, 417, and 419 allow fluid flow between connectors despite the orientation. FIG. 4 shows the same configuration as that shown in FIG. 3 except that a section of the hollow fiber filter 401 is treated to become a hydrophobic vent layer 411 between the hollow fiber lumen and the permeate chamber. Negative pressure applied to the permeate chamber allows air to be drawn through hydrophobic vent filter 411 and fluid is then aspirated in the fiber lumen of fiber filter 401. When the fluid contacts hydrophobic vent filter 411, flow immediately stops. Hydrophobic vent filter 411 may be a flat filter at the top of hollow fiber

401 between the fiber lumen and the permeate chamber or a hollow fiber filter with an upper hydrophobic section of approximately one inch or less with the remainder of the fiber being hydrophilic in nature.

[0082] For concentration tips in which air will not draw through the filter, such as ultrafiltration membrane filters that must be packaged wet, methods of contacting sample fluid with the fiber lumen, while not allowing the fluid to exit the disposable tip and contact the concentrator unit, are disclosed. The first method uses a section of hydrophobic vent filter as discussed in FIG. 2 and FIG. 4.

[0083] Another method for contacting fluid with the hollow fiber is by using a syringe pump connected to the fiber lumen to draw a volume of air into the syringe body equivalent to the internal volume of the fiber lumen thereby aspirating liquid into the fiber lumen of the fiber filter. In this way fluid does not pass above the disposable tip, but stops at or near the top of the hollow fiber filter.

[0084] Another method for contacting fluid with the hollow fiber filter is by using a pump to draw a volume of air out of the fiber lumen and using an optical or other sensor to stop the fluid flow at the top of the hollow fiber filter. An optical sensor can be attached to the concentrator device, rather than to the disposable tip, and monitor a clear section of the disposable tip above the hollow fiber filter. In this way fluid does not pass above the disposable tip.

[0085] Another method of contacting fluid with the hollow fiber filter is by dispensing a volume of clean dilution fluid from the concentrator device into the hollow fiber filter and out of the opening and into the sample container. In this way the entire retentate side of the hollow fiber is filled with fluid and the permeate pump can now be activated to draw the sample into the CPT.

[0086] FIG. 5 shows a CPT 500 having pin type connectors 515, 517, and 519, according to an exemplary embodiment of the present subject disclosure. CPT 500 also includes a connector 513, a permeate purge 507, a permeate draw 509, and a hollow fiber filter 501. The CPT in FIG. 5 has a configuration like that shown in FIG. 3, except that the fluidics connections are through three pin type connectors as opposed to the annular connections. Though these connections require a specific orientation, they are more reliable and cost-efficient than the annular connections of FIG. 3.

[0087] FIG. 6 shows a CPT 600 including a primary male connector 613, according to an exemplary embodiment of the present subject disclosure. CPT 600 also includes a hollow fiber filter 601, a permeate purge 607, and a permeate draw 609. Connector 613 includes fluidics connections 615, 617, and 619 at various lengths from the top end. This tip connects to a female connector with integrated annular connections on the concentrator unit. Hollow fiber filter 601 includes a hydrophobic vent filter 611 near the top.

[0088] FIG. 7 shows a CPT 700 including a primary male connector 713, according to an exemplary embodiment of the present subject disclosure. CPT 700 also includes a hollow fiber filter 701, a permeate purge 707, and a permeate draw 709. Connector 713 includes fluidics connections 715, 717, and 719 at various lengths from the top end. CPT 700 connects to a female connector with integrated annular connections on the concentrator unit. Hollow fiber filter 701 is similar to the hollow fiber filter of FIG. 6, with the exception that the hydrophobic vent filter is replaced with an integrated conductive sensor 711 to assist in startup.

[0089] FIG. 8 shows a CPT 800 including a primary male connector 813, according to an exemplary embodiment of the present subject disclosure. CPT 800 also includes a hollow fiber filter 801, a permeate purge 807, and a permeate draw 809. Connector 813 includes fluidic connections 815, 817, and 819 at various lengths from the top end. CPT 800 connects to a female connector with integrated annular connections on the concentrator unit. Hollow fiber filter 801 is similar to the configuration shown in FIG. 7, with the exception that the conductive sensor is replaced with an optical sensor section that allows for an optical fluid sensor 811 within the concentrator unit to sense the fluid location.

[0090] FIGS. 9-11 show one configuration for a CPT, according to an exemplary embodiment of the present subject disclosure. FIG. 9 shows a complete CPT 900. FIG. 10 shows an exploded view of CPT 1000. FIG. 11 shows the port used for potting the lower end of the fiber during production.

[0091] FIG. 9 shows a complete CPT 900, according to an exemplary embodiment of the present subject disclosure. CPT 900 includes a connector 913, a hollow fiber filter 901, a permeate purge 907, and a permeate draw 909. Connector 913 includes fluidic connections 915, 917, and 919.

[0092] FIG. 10 shows an exploded view of a CPT 1000, according to an exemplary embodiment of the present subject disclosure. Two halves join to make a connector 1013, a permeate purge 1007, a permeate draw 1009, a throughbore for a hollow fiber filter 1001, a hydrophobic vent 1011, and potting 1003. CPT 1000 is snapped together using fasteners. There are many other ways of connecting the two halves that will become apparent to those having skill in the art upon reading this disclosure.

[0093] FIG. 11 shows a potting port 1104 for a CPT 1100, according to an exemplary embodiment of the present subject disclosure. Once assembled, potting port 1104 allows the user to put potting into the tip of CPT 1100 where it holds hollow fiber filter 1101 in place. Potting is injected with a syringe or other utensil capable of inserting potting into potting port 1104. A machine assembling the concentrating pipette tip may also employ a syringe or other utensil to insert the potting.

[0094] FIG. 12 shows another potential configuration for a CPT 1200, according to an exemplary embodiment of the present subject disclosure. A configuration for a disposable concentrating tip uses a flat porous surface 1201 to divide the tip longitudinally into a permeate side and a side containing a retentate channel 1203. Retentate channel 1203 is enclosed on one longitudinal side by porous surface 1201 and on three sides by the impermeable walls of the tip. Channel 1203 is open on both ends; forming a bottom opening 1205 of the CPT 1200 and the retentate port 1217 contained within connector 1213. The permeate side contains a tube to contain permeate purge 1207 and tube to contain permeate draw 1209. Openings for permeate purge 1207 and permeate draw 1209 are contained within their respective ports 1215 and 1219 contained within connector 1213. To operate, CPT 1200 is attached to the concentrating unit and fluid is aspirated into CPT 1200 and through porous surface 1201. When the entire sample volume has passed through CPT 1200, the captured particles are eluted by a tangential flush of flat porous surface 1201 with a known volume of elution buffer or wet foam. Alternatively a backflush of liquid may be used with a secondary tangential sweep with liquid, foam, or a gas.

[0095] FIG. 13 shows a configuration for a CPT 1300 with a flat porous surface 1306 dividing the tip into an upper portion and a lower portion with an opening 1305 at the lower end and a connector 1310 at the upper end, according to an exemplary embodiment of the present subject disclosure. Porous surface 1306 may be a depth filter, electret filter, microsieve, charged filter, membrane, porous media or other porous surface. To operate, CPT 1300 is attached to the concentrator unit and fluid is aspirated into opening 1305 and through porous surface 1306. When the entire sample volume has passed through opening 1305 then the captured particles are eluted by backflushing the filter with a known volume of wet foam or liquid.

[0096] FIG. 14A shows another configuration for a CPT 1400, according to an exemplary embodiment of the present subject disclosure. FIG. 14A shows a CPT 1400 including a connector 1413, two hollow fiber filters 1401, a permeate draw 1409, and potting 1403 to secure the hollow filter. Connector 1413 further includes fluidic connections 1415, 1417, and 1419. Hidden from view underneath connector 1413 is a permeate purge. The permeate purge can be more clearly seen in FIG. 14B.

[0097] FIG. 14B shows the end having connector 1413 of the CPT, according to an exemplary embodiment of the present subject disclosure. Connector 1413 includes fluidic connections 1417, 1415, and 1419. Fluidic connection 1415 connects with permeate purge 1407 and a permeate purge line of the concentrating unit. Fluidic connection 1419 ports fluid from permeate draw 1409 to a permeate pump of the concentrating unit. Fluidic connection 1417 ports extraction foam or fluid from the concentrating unit to the hollow fiber filter. Potting 1403 secures hollow fibers 1401 into the CPT.

[0098] FIG. 14C shows the end having opening 1405 of the CPT, according to an exemplary embodiment of the present subject disclosure. Opening 1405 receives fluid from a sample for concentration. Hollow fiber filter 1401 is held in place by potting 1403 at opening 1405. Permeate draw 1409 draws permeate from the sample.

[0099] FIG. 15 shows a concentrating unit 1521 gathering a sample 1523 through a CPT 1500, according to an exemplary embodiment of the present subject disclosure. Sample 1523 is placed on a tray 1525 while arm 1527 is raised. CPT 1500 is attached to arm 1527, and arm 1527 is lowered so that CPT 1500 is submerged in sample 1523. An operator then starts concentrating unit 1521, and the sample is aspirated into CPT 1500. When the entire sample has been processed the concentrated sample is dispensed into a sample container.

[0100] FIG. 16 shows a method of using a concentrating unit having a CPT, according to an exemplary embodiment of the present subject disclosure. First, the arm is raised S1631 so that the CPT can be inserted into the arm S1632. A lever is pushed and the CPT is pushed into the CPT port. The CPT port contains a gasketed sealing surface and a spring loaded surface to hold the CPT ports in place and seal the connections from leakage. This sealing surface contains connectors for the three CPT connecting ports. Next, the sample is placed on the tray S1633. The arm of the concentrating unit is then lowered S1634, dipping the CPT into the bottom of the sample, but without blocking the fiber opening. A user presses start to turn on the vacuum S1635 and the sample begins concentrating within the CPT. Once the sample has been pulled through the CPT, a user can stop the sample processing by pressing a button on the concentrator

or the concentrator will detect stoppage of flow through the tip and automatically stop the sample processing. A user may then choose to dispense the concentrate into the original sample container or a user may replace the original sample container with a new extraction sample container. The user then presses the extraction button **S1636** activating the extraction cycle. The extraction process is then activated to recover the capture particles **S1637** into a concentrated final volume.

[0101] In one aspect, the porous surface used for capturing the particles is a flat fibrous type filter, a flat membrane type filter, or a flat porous surface such as a microsieve or nucleopore filter. This flat filter may be positioned lengthwise in the disposable tip such that it separates the interior space of the disposable tip into a retentate side and a permeate side. Capture of the particles of interest and recovery with the elution fluid are performed in much the same way as with the hollow fiber filter disposable tip described above with the exception that capturing and recovery of particles takes place on the retentate side of the flat membrane rather than within the hollow fiber filter lumen. The length of the retentate, in this case, is enclosed on one wall by the porous surface and on the remaining three walls by the impermeable walls of the disposable tip. In the case of the configuration and the hollow fiber filter configuration the particles of interest are recovered by sweeping through the retentate, in a direction tangential to the porous surface, with a foam or liquid elution fluid. Alternatively the particles may be recovered by backflushing the porous surface with a fluid or by any combination of backflushing or tangential flushing with a liquid or gas.

[0102] In another configuration the porous surface used for capturing the particles is a filter or porous surface dividing the disposable tip into a lower retentate reservoir and an upper permeate reservoir. In this case particles of interest are captured onto the bottom side and into the structure of the porous surface. Said particles are then recovered by backflushing the porous surface with a wet foam or liquid elution fluid. The preferred embodiment of this configuration is for charged filters with recovery by way of backflushing with wet foam.

[0103] FIGS. **17A** and **17B** show an alternate configuration for a CPT **1700**, according to an exemplary embodiment of the present subject disclosure. FIG. **17A** shows a CPT **1700** including an opening **1705**, a fiber filter **1701**, and a permeate draw **1709**. In this embodiment, there is not a permeate purge. According to this embodiment, permeate draw **1709** is shortened, similar to the length of the permeate purge in other embodiments. Each of fiber filter **1701** and permeate draw **1709** is secured within CPT **1700** with potting **1703**. A connecting portion **1713** allows CPT **1700** to be connected to a concentrating unit for operation of CPT **1700**. Within connecting portion **1713**, two ports are contained. FIG. **17B** shows the two ports, which include a port **1717** connected to fiber filter **1701** and a port **1719** connected to permeate draw **1709**. During operation, the permeate chamber fills with fluid and stays full throughout the sample processing. During elution of fiber filter **1701**, instead of pressurizing the permeate chamber a valve is closed on permeate draw **1709** leaving a liquid filled permeate chamber. During elution it isn't necessary to pressurize the permeate chamber because there is void space for the fluid to go into on the permeate side, so the elution fluid or foam will not readily pass through fiber filter **1701**.

[0104] In one aspect of this configuration, instead of using a permeate valve within the concentration unit a check valve is integrated into the permeate draw **1709** such that a single connection can be used for the CPT. In this way, a sample is aspirated into the CPT and through the filter by applying a permeate pump to connecting portion **1713**. The permeate chamber fills with fluid and stays throughout the sample processing. During elution of fiber filter **1701**, the elution fluid or foam is dispensed into connecting portion **1713** which causes the check valve with in permeate draw **1709** to close causing the elution fluid or foam to pass through fiber filter **1701**.

[0105] FIGS. **18A** and **18B** show another concentrating unit for gathering a sample through a CPT, according to an exemplary embodiment of the present subject disclosure. Similar to the unit shown in FIG. **15**, the present exemplary embodiment shows a concentrating unit **1821** for gathering a sample **1823** through a CPT **1800**. Sample **1823** is placed on a tray **1825**, while a fluidics head, or arm **1827** is raised. CPT **1800** is attached to arm **1827** via a CPT interface **1813**. In FIG. **18B**, arm **1827** is lowered so that CPT **1800** is submerged in sample **1823**. An operator then starts concentrating unit **1821** by inputting commands via user interface **1824**, and the sample is aspirated into CPT **1800**. When the entire sample has been processed as described herein, the concentrated sample is dispensed into a sample container **1835**. Arm **1827** has a quick release fixture that holds CPT **1800** and interfaces with the permeate and elution fluid ports on CPT **1800**. Arm **1827** can be raised to allow a sample container to be placed on sample platform **1825**, and lowered, to allow CPT **1800** to reach to the bottom of the sample container **1823**. A vacuum pump (not shown) is located in the main enclosure of unit **1821**. A flexible umbilical cable may be used to connect arm **1827** with the main enclosure with fluid and electrical lines. A permeate outlet port **1839** may be used to dispense the permeate extracted from CPT **1800**. A computer interface **1837** is provided to receive commands from and output information to an external computer. A power button **1836** and a power interface **1838** are also provided.

[0106] FIG. **19** shows a system for gathering a sample through a CPT **1900**, according to an exemplary embodiment of the present subject disclosure. This exemplary embodiment is different from that shown in previous embodiments, in that only two ports are required: an elution fluid port **1917**, and a permeate port **1919**. However the underlying concept is similar to that outlined in the aforementioned embodiments: a system that utilizes a single use disposable filter cartridge with a sample port that draws in a relatively large liquid sample with a low concentration of particles, the particles are captured on the filter surface while the liquid is drawn through to the permeate, then an elution step re-suspends the particles into a relatively low volume of liquid with a high concentration of particles and releases it through the same port the sample was drawn into. The present exemplary embodiment reduces the volume of elution fluid needed, without requiring positive pressure on the permeate side **1908** of filter **1901**. Simply, a three-way permeate valve **1928** is closed in order to maintain positive pressure on permeate side **1908**, such that any elution fluid stays on the retentate side **1906**. Being able to close valve **1928** without using excess pressure enables a more consistent final volume of elution fluid dispensed through port **1905**.

[0107] In an initial state, elution fluid valve 1926 is closed, three way permeate valve 1928 is linking the permeate port 1919 to vacuum source 1934 with the port leading to the check valve 1930 closed off, and the vacuum source 1934 is deactivated. First, an unused CPT 1900 is connected to the system by inserting the elution fluid port 1917 and permeate port 1919 of CPT 1900 into the CPT interface 1913. The CPT sample port 1905 is lowered into a sample container and therefore the liquid sample therein. At this point an automated concentration process may be initiated, for instance via a user input. Vacuum source 1934 is activated, and the air in the permeate side 1908 of CPT 1900 is evacuated. At this point air can travel through the filter 1901 (which is a hydrophilic filter as described above), therefore the retentate side 1906 of the CPT 1900 is also evacuated of air, resulting in the liquid sample being drawn through sample port 1905 and into the retentate side 1906 of CPT 1900. The liquid passes through the filter 1901, into the permeate side 1908 of the CPT 1900, through the permeate port 1919, through the permeate valve 1928, past vacuum source 1934, and through a permeate outlet. Moreover, the sample fills the retentate side 1906 of the CPT 1900 as high as the exposed area of the filter 1901. The sample does not fill any more of the retentate side 1906 due to the elution fluid valve 1926 being closed, resulting in an air pocket being trapped within the elution fluid port 1917. This prevents the sample from coming into contact with any part of the concentrating unit instrument's fluidics, including orifice 1922 and valve 1926, enabling multiple consecutive uses of disposable CPTs without needing to clean or sterilize the concentrating unit.

[0108] As the sample is drawn through the filter 1901, the particles suspended in the liquid sample are trapped on the surface of filter 1901 on the retentate side 1906 of the CPT 1900. Once the entire sample has been drawn through the filter due to vacuum 1934, ambient air continues to enter through the sample port 1905. In the case that a hydrophobic filter 1815 is used, the air will be drawn through the filter 1901 behind the liquid sample into the permeate side 1908. In the case that a hydrophilic filter 1901 is used, the air will not be able to pass through the now wet filter, due to the significant transmembrane pressure required to draw air into the pores of a wetted hydrophilic membrane filter. In this case, the retentate side 1906 of the filter 1901 fills with air, and the filter 1901 will not allow the air to pass through, leaving the permeate side 1908 full or partially full of liquid. The vacuum source 1934 may now be deactivated, and the elution process begins. The permeate valve 1928 switches to link the permeate port 1919 to the ambient air line 1932 through the check valve 1930. This allows air to flow into the permeate side 1908 of CPT 1900, returning it to atmospheric pressure.

[0109] An elution foam is used to elute the particles from the filter. An elution fluid is forced into the elution fluid valve 1926 at a high pressure. When the elution valve 1926 opens, the high pressure liquid passes through the orifice 1922. The pressure drop across the orifice controls the flow of the elution fluid and, when using an elution fluid containing a surfactant and carbon dioxide, causes a wet foam to be produced. The wet foam enters the CPT 1900 through the elution port 1917. The wet foam then re-suspends the particles that were captured on the surface of the filter 1901. Meanwhile, the check valve 1930 prevents any flow from the permeate side 1908 of the CPT 1900 to the ambient air

port 1932, thereby maintaining a positive pressure in permeate side 1908, and keeping the amount of elution fluid going through the filter 1901 to a minimum. The flow of foam being tangential to filter 1901 enables collection of particles from the retentate side 1906 of filter 1901, resulting in a particle laden foam that exits the sample port 1905 thereby providing a final concentrated sample ready for analysis.

[0110] In a three port CPT shown in prior embodiments, the additional permeate line reaching to the very bottom of the permeate side of the CPT enabled all of the fluid in the permeate side of the filter to be removed at the end of the run by allowing air to purge through the top permeate port and sweep the liquid into the line reaching to the bottom of the permeate side. Removing all the liquid from the permeate side is beneficial because it allows gas pressure to be applied to the permeate side, thereby preventing any elution fluid from passing through the filter. This allows for smaller final concentrated volumes, and increases the consistency of the final volume. Applying pressure to the permeate without first removing all of the liquid may cause it to flow back through to the retentate side and thereby increase the retentate fluid volume and retentate fluid volume variability. However, the two port CPT shown in the present exemplary embodiment is less costly to manufacture, and only results in a slight increase in a final concentrated volume, yet being sufficient for its intended purpose.

[0111] FIG. 20 shows an external view of a CPT 2000 having a flat filter, according to an exemplary embodiment of the present subject disclosure. CPT 2000 comprises a filter housing 2002, an elution fluid port 2017, a permeate port 2019, and a sample port 2005. Although a flat filter is shown, there is no difference in operations of a CPT having a flat filter or any other filter type, as will be disclosed in subsequent embodiments.

[0112] FIG. 21 shows a horizontal cross section of a CPT having a flat filter, according to an exemplary embodiment of the present subject disclosure. Filter housing 2102 comprises a filter housing sealing area 2103, enabling both sides of filter housing 2102 to be coupled together. A filter sealing area 2104 holds in place a filter 2101, which is shown as a flat membrane filter, but can be any filter type. In the case of a flat membrane filter, filter support ribs 2110 enable the filter to stay in the center, and provides space for a retentate side 2106 of filter 2101, and a permeate side 2108 of filter 2101.

[0113] FIG. 22 shows a shortened vertical cross section of a CPT having a flat filter, according to an exemplary embodiment of the present subject disclosure. According to this exemplary embodiment, a CPT comprises a filter housing 2202, an elution fluid port 2217, a permeate port 2219, and houses a flat membrane filter 2201. A retentate side 2206 of the filter is connected to elution fluid port 2217 and sample port 2205, and a permeate side 2208 of filter 2201 is coupled to permeate port 2219.

[0114] FIGS. 23A and 23B show views of a CPT having a hollow fiber filter, according to an exemplary embodiment of the present subject disclosure. According to this exemplary embodiment, a CPT 2300 comprises a filter housing 2302, an elution fluid port 2317, a permeate port 2319, a sample end 2305, and one or more hollow fiber filter elements 2301 encased in a potting material. The hollow fiber filter elements 2301 are similar to those described in previous embodiments, such as that of FIG. 1.

[0115] FIG. 24 shows a vertical cross section of a CPT 2400 having a hollow fiber filter, according to an exemplary embodiment of the present subject disclosure. According to this embodiment, a CPT 2400 comprises a filter housing 2402, an elution fluid port 2417, a permeate port 2419, and one or more hollow fiber filter elements 2401, held in place by filter potting material 2403. Although three hollow fiber filter elements 2401 are shown, more or less would be conceivable by persons having ordinary skill in the art in light of this disclosure. Open ends in the hollow fiber filter elements 2401 serve as sample ports 2405 to draw up a sample liquid.

[0116] FIG. 25 shows a horizontal cross section of a CPT having a hollow fiber filter, according to an exemplary embodiment of the present subject disclosure. A filter housing 2502 encloses a plurality of hollow fiber filter elements 2501. An inside surface of the hollow fiber filter elements 2501 serves as a filter retentate side 2506, and the outside of the hollow fiber filter elements 2501 serves as a filter permeate side 2508.

[0117] The vertically oriented flat and hollow fiber filters in the above embodiments of FIGS. 19-25 extend from the top end of the CPT, i.e. adjacent the elution and permeate ports at the connection point to the concentrator, to the bottom of the filter. As described with respect to FIG. 1, such an orientation and length enables particles to be recovered by the tangential flush described herein in a direction of travel from the top to the bottom, over a very large membrane surface area, and enables processing large volumes quickly, while using only a very small volume of liquid (or wet foam) to be used to recover the particles due to the very small cross sectional area of the retentate. This further allows for greatly increased concentration factors and allows for use in a pipette by the unconcentrated sample being drawn in through the bottom opening and the concentrated sample being dispensed through the same opening. Moreover, the separate permeate port enables the sample volume processed to be governed by the membrane surface area/membrane flow rate and a time taken to process, versus being limited based on the volume of the tip itself, as disclosed by the current state of the art.

[0118] Further, as described herein, a volume outside the retentate surface of the filter is in fluid communication with the elution port during elution, and positive pressure on this side during elution may be transferred to the permeate side of the filter during elution. For example, during the filter elution process, the introduction of elution fluid or of wet foam can cause a significant increase in pressure on the retentate side. This increase in pressure is due to the relatively small cross sectional area of the retentate compared to the relatively fast rate at which the elution fluid or foam is pushed through the retentate volume tangential to the filter surface. This momentary increase in pressure can cause a portion of the elution fluid or wet foam to flow through the filter from the retentate side to the permeate side, resulting in reduced elution efficiencies and variable elution volumes.

[0119] In order to reduce flow of elution fluid or wet foam from the retentate side to the permeate side, an equal or nearly equal pressure must be applied to the permeate side of the filter. There are multiple ways that this pressure can be applied. After processing a sample, but before elution, negative pressure approaching one atmosphere remains on the permeate side of the filter. In one embodiment, this negative pressure can be relieved using a three-way valve

and check valve on the permeate draw, as described herein. During sample processing, the three-way valve is positioned so that flow is allowed through the permeate draw line. After the sample has been processed, but before elution, the three-way valve is actuated so that the permeate draw is closed, but air is allowed to flow through the check valve and into the permeate chamber. The three-way valve is left in this position during the elution process, with the check valve closing off the permeate chamber. In this way, the permeate chamber is maintained at near atmospheric pressure, but is closed off so that very little elution fluid or wet foam can pass through to the permeate side.

[0120] In another embodiment, a separate valve may be added to act as a link between the retentate line and the permeate line. After processing a sample the three-way valve and check valve is used to return the permeate chamber to atmospheric pressure. Then the separate valve is opened during the elution process to allow elution fluid or wet foam to momentarily flow towards the permeate chamber (as pressure on the retentate side increases), so that equal, or near equal, pressure is maintained on both sides of the filter.

[0121] In another embodiment, pressure may be applied to the permeate chamber using an external pressure source such as a pump, house air, compressed gas, or pressure from the elution fluid container coupled to the concentrating unit. In yet another embodiment, the permeate chamber is allowed to fill, or is intentionally filled, with permeate fluid or another incompressible fluid and is valved closed, so that no space is available for elution fluid or wet foam to travel through to the permeate chamber. In this way the entire elution fluid or wet foam is allowed to act on the retentate side of the filter during the elution process.

[0122] In exemplary embodiments of the present subject disclosure, the concentrating pipette tip (CPT) may include two filters instead of one, thereby increasing the surface area of the filter without increasing the size of the cartridge housing. FIGS. 26-28 describe a CPT having two filters, according to exemplary embodiments of the present subject disclosure. FIG. 26 shows an isometric view of a CPT 2600 having two filters, according to an exemplary embodiment of the present subject disclosure. CPT 2600 is constructed with two housing halves 2602_A and 2602_B, each of which houses a filter with a permeate side and a retentate side. CPT 2600 further comprises an elution fluid port 2617 enabling foam to be let in to CPT 2600, a permeate fluid port 2619, and a sample end 2605 that enables letting in a sample and providing a channel for the retentate fluid.

[0123] FIG. 27 shows an exploded view of a CPT 2700 having two filters, according to an exemplary embodiment of the present subject disclosure. CPT 2700 includes two housing halves 2702_A and 2702_B, that may be sandwiched together to house flat filter membranes 2701_A and 2601_B, a permeate fluid channel 2743 that is in fluid communication with permeate port 2719, filter support ribs 2710, and a retentate fluid channel 2742 that is in fluid communication with an elution fluid inlet port 2717. Retentate channel 2742 is formed by the space between the two halves 2702_A and 2702_B being sealed together. Further, front and rear permeate channel covers 2741_A and 2741_B are used to cover the permeate channel, and allow for draining the permeate channel.

[0124] As described above, the presence of two filters provides a larger surface area when compared to the single-filter designs, thereby increasing the sample flow rate, and reducing the effects of particle loading. To achieve a similar surface area with a single filter would require a significantly larger housing, which would in turn reduce elution efficiency. Further, the cross sectional geometry is improved when compared to a single filter design. FIG. 28 shows a cross-sectional view of a CPT 2800 having two filters, according to an exemplary embodiment of the present subject disclosure. Similar to FIGS. 26 and 27, CPT 2800 has two housing halves 2802_A and 2802_B that may be sandwiched together to house a permeate line 2819 in fluid communication with a permeate draw and a permeate fluid channel 2843, a pair of filters 2801_A and 2801_B that are coupled to the top of the housing halves by filter sealing areas 2804_A and 2804_B and held in place by filter support ribs 2810, and a retentate fluid channel 2843 formed by the space in between the two housing halves 2802_A and 2802_B. Filter housing sealing area 2803 provides a contact point for connecting the two housing halves 2802_A and 2802_B.

[0125] The pair of vertically oriented filters in the above embodiments of FIGS. 26-28 extend from the top end of the CPT, i.e. adjacent the elution and permeate ports at the connection point to the concentrator, to the bottom of the filter, i.e. adjacent the sample draw/retentate fluid port. As described with respect to FIG. 1, such an orientation and length enables particles to be recovered by the tangential flush described herein in a direction of travel from the top to the bottom, over a very large membrane surface area, and enables processing large volumes quickly, while using only a very small volume of liquid (or wet foam) to be used to recover the particles due to the very small cross sectional area of the retentate. In addition to the larger surface area gained by the two-filter CPT, the vertical orientation further allows for greatly increased concentration factors and enables efficient usage of disposable or single-use CPTs by drawing in the sample and dispensing the retentate fluid through the same opening.

[0126] For the purposes of this disclosure, a permeate chamber is any volume that is formed between a permeate surface of a membrane and a housing of the CPT, and a retentate chamber is any volume that is formed between a retentate surface of a membrane and said housing. For a dual-filter CPT, a retentate chamber may be formed between the retentate surfaces, and a permeate chamber may be formed between each permeate surface and its respective housing. In a hollow fiber filter CPT, the permeate chamber may be formed by the combined volume external to each hollow fiber filter, and the retentate chamber may be formed by the combined inner volume of each hollow fiber filter. In alternative embodiments, the positions and configurations of the permeate and retentate chambers may be reversed.

[0127] The embodiments disclosed herein enable automated concentration and simultaneous clean buffer exchange, including removal of non-target particles and soluble and insoluble components, which may inhibit subsequent analysis and detection measures, prior to elution of target particles into a new clean fluid that is compatible with the selected analysis or detection method. Additionally, wash steps may be performed after the sample is processed through the membrane, but before sample elution, by processing wash fluids, such that they are washed over the sample, retained on the filter, and through the filter to the

permeate. Performing a buffer exchange and/or washing the sample to remove potential inhibitors as shown herein saves time and effort and provides higher quality samples to the detector or analyzer. Moreover, samples having different concentrations, viscosities, or makeups may be processed dynamically by incorporating a flow sensor, pressure sensor, or bubble sensor in the concentrating unit to detect when a sample has been fully processed. The filter type that is generally the most appropriate for use in the single-use CPT is a hydrophilic membrane filter in the pore size range required for concentration of particles in the size range of interest. Hydrophilic membrane filters, in this pore size range, possess a unique characteristic in that once wetted with water they require a significant transmembrane pressure to allow air to begin to flow through the membrane. This unique feature creates a significant drop in flow rate through the filter, which also often results in an increase in negative pressure and increased formation of bubbles in the permeate side due to the increased negative pressure. These changes can be detected using sensors, as stated above, and in this way the point at which the sample volume has been entirely processed through the tip can be determined and the sample processing step may be automatically completed and elution process automatically performed or the user may be signaled to initiate the elution. There are many types of liquid flow sensors and switches available commercially, and that will be familiar to one skilled in the art, that can be applied to this application. Additionally, pressure sensors and bubble sensors may be used to determine the end of the sample. Moreover, hydrophilic membranes ensure single-use operation, i.e. rendering the CPT inoperable for more than one use, therefore ensuring safety and preventing cross-contamination across samples.

[0128] The foregoing instrumentalities have significant utility in medical, environmental, or security applications. In exemplary embodiments, concentration in the manner described facilitates aerosol sampling for pathogens or bio-terrorism threat agents that can withstand being placed in a liquid sample for analysis. A list of such pathogens may be provided, for example, as recognized by the Center for Disease Control (CDC). These organisms may be studied using conventional techniques that are facilitated by the concentration of samples as described above.

TABLE 1

| CDC CATEGORY A AND B BIOTERRORISM AGENTS LIST |
|--|
| CATEGORY A |
| Anthrax (<i>Bacillus anthracis</i>) |
| Botulism (<i>Clostridium botulinum</i> toxin) |
| Plague (<i>Yersinia pestis</i>) |
| Smallpox (<i>Variola major</i>) |
| Tularemia (<i>Francisella tularensis</i>) |
| Viral hemorrhagic fevers (filoviruses [e.g., Ebola, Marburg] and arenaviruses [e.g., Lassa, Machupo]) |
| CATEGORY B |
| Brucellosis (<i>Brucella</i> species) |
| Epsilon toxin of <i>Clostridium perfringens</i> |
| Food safety threats (e.g., <i>Salmonella</i> species, <i>Escherichia coli</i> O157:H7, <i>Shigella</i>) |
| Glanders (<i>Burkholderia mallei</i>) |
| Melioidosis (<i>Burkholderia pseudomallei</i>) |
| Psittacosis (<i>Chlamydia psittaci</i>) |
| Q fever (<i>Coxiella burnetii</i>) |

TABLE 1-continued

| CDC CATEGORY A AND B BIOTERRORISM AGENTS LIST |
|--|
| Ricin toxin from <i>Ricinus communis</i> (castor beans) |
| Staphylococcal enterotoxin B |
| Typhus fever (<i>Rickettsia prowazekii</i>) |
| Viral encephalitis (alphaviruses [e.g., Venezuelan equine encephalitis, Eastern equine encephalitis, Western equine encephalitis]) |
| Water safety threats (e.g., <i>Vibrio cholerae</i> , <i>Cryptosporidium parvum</i>) |

TABLE 2

| SECONDARY POTENTIAL BIOLOGICAL THREAT AGENTS | |
|--|---|
| Viri/prions | <i>Histoplasma capsulatum</i> |
| Flaviviruses (Yellow fever virus, West Nile virus, Dengue, Japanese Encephalitis, TBE, etc.) | <i>Cryptococcus neoformans</i> |
| Hepatitis (A, B, C) | <i>Aspergillus niger</i> |
| Prions (CJD, BSE, CWD) | Pathogenic fungi |
| Alphaviruses (VEE, EEE, WEE) | <i>Acromonium</i> spp. |
| Nipah virus | <i>Alternaria alternata</i> |
| Rabies virus | <i>Apophysomyces elegans</i> |
| Rhinovirus (could be modified?) | <i>Aspergillus terreus</i> |
| Polioviruses | <i>Bipolaris</i> spp. |
| Hantaviruses | <i>Bipolaris spicifera</i> |
| Filoviruses (Ebola, Marburg, Lassa) | <i>Blastoschizomyces capitatus</i> |
| Bacilli | <i>Candida krusei</i> |
| <i>Mycobacterium tuberculosis</i> , drug resistant | <i>Candida lusitanae</i> |
| Mycobacteria other than TB, like <i>C. leprae</i> | <i>Candophilophora bantiana</i> |
| <i>Streptococcus pneumoniae</i> | <i>Cunnihamella bertholletiae</i> |
| <i>Streptococcus pyogenes</i> | <i>Curvularia lunata</i> |
| <i>Streptococcus aureus</i> | <i>Exserohilum rostratum</i> |
| <i>Clostridium tetani</i> | <i>Fusarium moniliforme</i> |
| <i>Clostridium difficile</i> | <i>Fusarium solani</i> |
| <i>Bacillus cereus</i> | <i>Hansenula anomala</i> |
| <i>Coxiella burnetii</i> (Q fever) | <i>Lasioidiodia theobromae</i> |
| <i>Francisella tularensis</i> | <i>Malassezia furfur</i> |
| <i>Borrelia recurrentis</i> | <i>Paecilomyces lilacinus</i> |
| <i>Rickettsia rickettsii</i> | <i>Paecilomyces bariotii</i> |
| <i>R. prowazekii</i> | <i>Penicillium mameffeii</i> |
| <i>Shigella sonnei</i> | <i>Phialemonium curvatum</i> |
| <i>Bartonella henselae</i> | <i>Phialophora parasitica</i> |
| <i>Yersinia enterocolitica</i> | <i>Phialophora richardsiae</i> |
| <i>Yersinia pseudotuberculosis</i> | <i>Ramichloridium</i> spp. |
| <i>Neisseria meningitidis</i> | <i>Rhizomucor pusillus</i> |
| <i>Legionella pneumophila</i> | <i>Rhizopus rhizopodiformis</i> |
| <i>Burkholderia pseudomallei</i> | <i>Rhodotorula rubra</i> |
| <i>Pasturella multocida</i> | <i>Sacchromyces cerevisiae</i> |
| Other Pathogenic Microorganisms | <i>Scedosporium prolificans</i> |
| <i>Cryptosporidium parvum</i> | <i>Trichosporon beigeli</i> (T. asahii) |
| | <i>Wangiella dermatitidis</i> |

TABLE 3

| PHYSICAL SIZES OF SOME AGENTS AND SURROGATES | |
|--|--|
| TARGET | PHYSICAL SIZE |
| <i>Bacillus thuringiensis</i> endospore | approximately 1 µm |
| <i>Bacillus anthracis</i> endospore | approximately 1 µm |
| <i>Yersinia pestis</i> | Gram negative rod-ovoid 0.5-0.8 µm in width and 1-3 µm in length |

TABLE 3-continued

| PHYSICAL SIZES OF SOME AGENTS AND SURROGATES | |
|--|--|
| TARGET | PHYSICAL SIZE |
| <i>Yersinia rohdei</i> | approximately 1 µm |
| Venezuelan Equine Encephalitis | 70 nm (0.07 µm) |
| Gamma-killed M52 | 2 mD or about 25 nm (0.025 µm) (but will pass through a 300 kD pore size but is retained by a 100 kD pore size Wick and McCubbin-ECBC) |
| Ovalbumin | 45 kD or 6 nm (0.006 µm) |
| Botulinum | 150 to 900 kD or 10 nm to 70 nm (0.01 µm to 0.07 µm) |
| Toxoid A | (Normally published as 150 kD however some publications state that toxoid A can be released as complexes comprised of the 150 kD toxin protein along with associated non-toxin proteins and can therefore be released in 900 kD, 500 kD, and 300 kD forms. |
| DNA | 1000 Bp or 600 kD up to 15,000 Bp or 9 mD |

[0129] The concentrating filter tips (CPTs) used in this disclosure may be any disposable filter tip, for instance, a 0.1 micron polyethersulfone filter which is sold by Assignee under part numbers CC8001-10 and CC8001-60, or 0.4 micron polycarbonate track etched membranes that are sold as CC8000-10 or CC8000-60. A flow rate of 100+ mL/min is supported, with an input sample volume range of up to 2L, and a final concentrated sample volume range that is user-selectable from, for instance, 200-1000 µL. Exemplary particle size capabilities are dependent on the CPT used, and can range from 0.1 µm-0.4 µm for bacteria, parasites, molds, spores, and whole cells. Ultrafiltration for virus and free DNA may also be conceivable to those having ordinary skill in the art in light of this disclosure. Further any filter or membrane filter in the standard range of ultrafiltration or microfiltration membrane filters as well as fibrous filters and filters with mechanisms for attraction, such as zeta potential filters, may be used in a CPT device for capture of particles ranging from less than 1 kD molecular weight or less than 0.001 µm to particles or organisms up to as large as 1 mm in diameter. Ultrafiltration membranes in the range of 1 kD to 1,000 kD can be used in CPTs for a variety of concentration applications including proteins and other soluble and insoluble materials and small particles including pyrogens. Free DNA, and free RNA may be captured and concentrated using filters in the approximate range of 0.001 µm to 0.02 µm or 1 kD to 300 kD. Virus may be captured and concentrated using filters generally in the physical or effective pore size range of 0.001 µm to 0.1 µm or in the general molecular weight cut-off range of 1 kD to 1,000 kD. Bacteria can be concentrated using membranes generally in the range of 0.01 to 0.5 µm. Moreover, any membrane with a physical or effective pore size sufficiently small enough to capture the particle of interest may be used and in some instances pore size significantly smaller than the target particle may be selected such that multiple targets, of different sizes may be concentrated into a single concentrated sample. Further, as can be appreciated by someone skilled in the art, novel membranes and filters, and membranes and filters other than

those mentioned here, may serve the purpose of retaining certain particles of interest and may provide a reliable filter for use in a CPT.

[0130] Moreover, although concentration of bacteria are disclosed, any of the disclosed embodiments may be used to concentrate bacterial pathogens within the blood in exemplary embodiments, after preparation of a blood sample by removal of blood components such as red blood cells, etc. Other applications include food and beverage processing and safety monitoring (of spoilage organisms and pathogens from process waters, liquid samples from food preparation surfaces, product wash waters), environmental monitoring (recreational water monitoring, waste water monitoring, legionella monitoring), drinking water, forensics, pharmaceutical manufacturing, and biodefense.

[0131] The foregoing disclosure of the exemplary embodiments of the present subject disclosure has been presented for purposes of illustration and description. It is not intended to be exhaustive or to limit the subject disclosure to the precise forms disclosed. Many variations and modifications of the embodiments described herein will be apparent to one of ordinary skill in the art in light of the above disclosure. The scope of the subject disclosure is to be defined only by the claims appended hereto, and by their equivalents.

[0132] Further, in describing representative embodiments of the present subject disclosure, the specification may have presented the method and/or process of the present subject disclosure as a particular sequence of steps. However, to the extent that the method or process does not rely on the particular order of steps set forth herein, the method or process should not be limited to the particular sequence of steps described. As one of ordinary skill in the art would appreciate, other sequences of steps may be possible. Therefore, the particular order of the steps set forth in the specification should not be construed as limitations on the claims. In addition, the claims directed to the method and/or process of the present subject disclosure should not be limited to the performance of their steps in the order written, and one skilled in the art can readily appreciate that the sequences may be varied and still remain within the spirit and scope of the present subject disclosure.

What is claimed is:

1. A device, comprising:

a filter enclosed within a housing, the housing comprising an opening for aspirating a fluid sample positioned at its bottom end and an elution port positioned at its top end, the filter positioned in a vertical orientation and spanning a length of the housing from the top end to the bottom end;

wherein a plurality of particles in the fluid sample are eluted from the a retentate surface of the filter and dispensed in a reduced fluid volume through the opening.

2. The device in claim 1, wherein the plurality of particles are eluted by an elution fluid flowing tangentially across the retentate surface of the filter from the top end to the bottom end.

3. The device in claim 1, further comprising a permeate port positioned adjacent the top end, the permeate port in fluid communication with a permeate chamber of the filter.

4. The device in claim 3, further comprising a connecting portion for connecting the elution port and the permeate port to a concentrating unit.

5. The device in claim 4, wherein the sample is aspirated by a vacuum source in the concentrating unit via the permeate port.

6. The device in claim 5, wherein one or more valves in the concentrating unit are used to return the permeate chamber to atmospheric pressure prior to elution of the particles.

7. The device in claim 6, wherein the one or more valves in the concentrating unit are used to close any external connections to the permeate port prior to elution.

8. The device in claim 3, wherein the permeate chamber is pressurized during or prior to elution.

9. The device in claim 3, wherein the permeate chamber is allowed to fill with liquid prior to elution.

10. The device in claim 3, wherein the permeate chamber is in fluid communication with the elution port during elution.

11. The device in claim 1, wherein the filter is one or more of a flat membrane filter, a hollow fiber filter, a flat depth filter, an electrostatically charged filter, or a microsieve.

12. The device in claim 1, further comprising a second filter that is vertically-oriented.

13. A device, comprising:

a first half of a housing coupled to a first filter, the first filter being vertically oriented and spanning a length of the first half of the housing; and

a second half of a housing coupled to a second filter, the second filter being vertically oriented and spanning a length of the second half of the housing;

wherein the first and second halves of the housing are sandwiched together to form a concentrating pipette tip; and

wherein a plurality of particles in a fluid sample aspirated via an opening positioned adjacent a bottom end of the housing are eluted from a retentate surface of the first and second filters and dispensed in a reduced fluid volume via the opening.

14. The device in claim 13, wherein a retentate chamber is formed from a volume between a retentate surface of each of the first and second filters.

15. The device in claim 13, wherein a permeate chamber is formed by a volume between each filter and its respective half of the housing.

16. A device, comprising:

a housing;

one or more hollow fiber filters enclosed within the housing, the one or more hollow fiber filters being vertically oriented and spanning a length of the housing;

an elution port positioned adjacent a top end of the housing for receiving an elution fluid from a concentrating unit external to the housing;

a permeate port positioned adjacent the top end of the housing, the permeate port for coupling the housing to a vacuum source in the concentrating unit; and

an opening positioned adjacent a bottom end of the housing for aspirating a fluid sample;

wherein a plurality of particles in the fluid sample are tangentially eluted from a retentate surface of each of the one or more hollow fiber filters and dispensed through the opening.

17. The device in claim 16, wherein the retentate surface comprises an inner surface of each of the one or more hollow fiber filters.

18. The device in claim **16**, wherein a permeate chamber is formed by a volume external to each of the one or more hollow fiber filters.

19. The device in claim **16**, further comprising a connection point positioned adjacent the top end of the housing, the connection point for connecting the elution port and the permeate port to the concentrating unit.

20. The device in claim **16**, wherein the elution fluid is a wet foam.

* * * * *