



US011936518B2

(12) **United States Patent**
Kumar et al.

(10) **Patent No.:** **US 11,936,518 B2**
(45) **Date of Patent:** ***Mar. 19, 2024**

(54) **INTERCONNECTION PLATFORM FOR REAL-TIME CONFIGURATION AND MANAGEMENT OF A CLOUD-BASED SERVICES EXCHANGE**

(58) **Field of Classification Search**
CPC H04L 41/0803; H04L 41/00; H04L 41/20; H04L 47/70; H04L 67/10; H04L 67/1097; H04L 67/2838; G06F 8/70; G06F 9/5072
USPC 709/223
See application file for complete search history.

(71) Applicant: **Equinix, Inc.**, Redwood City, CA (US)

(72) Inventors: **Parveen Kumar**, Fremont, CA (US); **Gagan Maheshwari**, Sunnyvale, CA (US); **Jaganathan Jeyapaul**, Saratoga, CA (US); **Brian J. Lillie**, Los Altos, CA (US)

(56) **References Cited**

U.S. PATENT DOCUMENTS

6,778,651 B1 8/2004 Jost et al.
7,526,734 B2 4/2009 Vasilev et al.
(Continued)

(73) Assignee: **Equinix, Inc.**, Redwood City, CA (US)

(*) Notice: Subject to any disclaimer, the term of this patent is extended or adjusted under 35 U.S.C. 154(b) by 0 days.
This patent is subject to a terminal disclaimer.

FOREIGN PATENT DOCUMENTS

CN 102246474 A 11/2011
CN 103209200 A 7/2013
(Continued)

(21) Appl. No.: **18/146,331**

OTHER PUBLICATIONS

(22) Filed: **Dec. 23, 2022**

Examination Report No. 1 from counterpart Australian Application No. 2022201786 dated Mar. 14, 2023, 3 pp.
(Continued)

(65) **Prior Publication Data**

US 2023/0208708 A1 Jun. 29, 2023

Related U.S. Application Data

(63) Continuation of application No. 17/646,375, filed on Dec. 29, 2021, now abandoned, which is a
(Continued)

Primary Examiner — Anthony Mejia

(74) *Attorney, Agent, or Firm* — Shumaker & Sieffert, P.A.

(51) **Int. Cl.**
G06F 15/173 (2006.01)
G06F 8/70 (2018.01)
(Continued)

(57) **ABSTRACT**

In one example, a cloud-based services exchange comprises a plurality of interconnection assets configured to connect a customer of the cloud-based services exchange to one or more cloud service providers, the plurality of interconnection assets including a virtual circuit by which the customer accesses a cloud service from the one or more cloud service providers; and an orchestration engine configured to modify the plurality of interconnection assets.

(52) **U.S. Cl.**
CPC **H04L 41/0803** (2013.01); **G06F 8/70** (2013.01); **G06F 9/5072** (2013.01); **H04L 41/00** (2013.01);
(Continued)

20 Claims, 24 Drawing Sheets

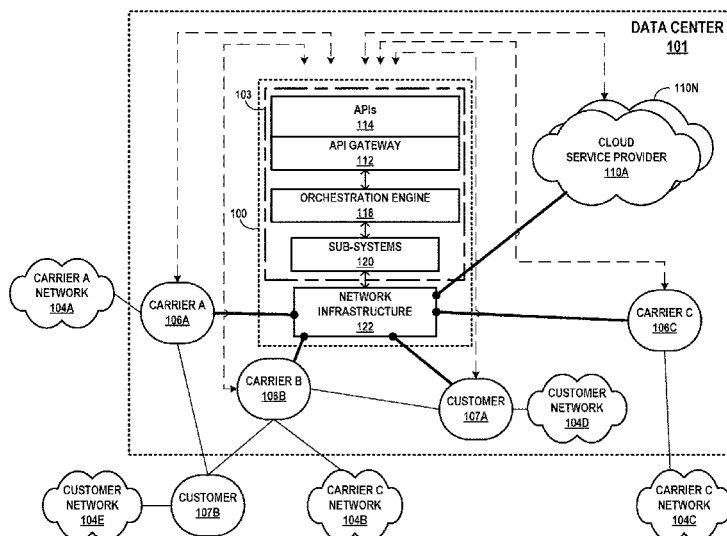

Related U.S. Application Data

continuation of application No. 17/007,929, filed on Aug. 31, 2020, now Pat. No. 11,218,363, which is a continuation of application No. 16/172,501, filed on Oct. 26, 2018, now Pat. No. 10,764,126, which is a continuation of application No. 15/887,165, filed on Feb. 2, 2018, now Pat. No. 10,116,499, which is a continuation of application No. 15/395,101, filed on Dec. 30, 2016, now Pat. No. 9,887,876, which is a continuation of application No. 14/927,451, filed on Oct. 29, 2015, now Pat. No. 9,886,267.

- (60) Provisional application No. 62/233,933, filed on Sep. 28, 2015, provisional application No. 62/072,976, filed on Oct. 30, 2014.
- (51) **Int. Cl.**
G06F 9/50 (2006.01)
H04L 41/00 (2022.01)
H04L 41/0803 (2022.01)
H04L 47/70 (2022.01)
H04L 67/10 (2022.01)
H04L 67/1097 (2022.01)
H04L 67/567 (2022.01)
- (52) **U.S. Cl.**
 CPC *H04L 41/20* (2013.01); *H04L 47/70* (2013.01); *H04L 67/10* (2013.01); *H04L 67/1097* (2013.01); *H04L 67/567* (2022.05)

(56) **References Cited**

U.S. PATENT DOCUMENTS

7,606,868	B1	10/2009	Le et al.
7,697,558	B2	4/2010	Pilon et al.
7,904,882	B2	3/2011	Hinks
8,046,440	B2	10/2011	Breiter
8,307,368	B2	11/2012	Wolf et al.
8,379,656	B2	2/2013	Waldrop et al.
8,407,190	B2	3/2013	Prahlad et al.
8,468,033	B2	6/2013	Gunn
8,509,249	B2	8/2013	Waldrop et al.
8,537,845	B2	9/2013	Waldrop et al.
8,583,503	B2	11/2013	Waldrop et al.
8,751,323	B2	6/2014	Waldrop et al.
8,752,017	B2*	6/2014	Hossain G06F 11/362 717/124
8,768,652	B1	7/2014	Mirtich et al.
8,825,861	B2	9/2014	Rao
8,891,439	B2	11/2014	Casey
8,892,708	B2	11/2014	Merrill et al.
9,009,858	B2	4/2015	Sapp et al.
9,110,976	B2	8/2015	Bolgert et al.
9,137,209	B1	9/2015	Brandwine et al.
9,203,784	B2	12/2015	Chang et al.
9,239,740	B2	1/2016	Zhao et al.
9,246,840	B2	1/2016	Anderson et al.
9,269,061	B2	2/2016	Jeyapaul et al.
9,300,633	B2	3/2016	Acharya et al.
9,338,214	B2	5/2016	Hinks
9,367,362	B2	6/2016	Kern
9,507,622	B2*	11/2016	Robinson G06F 9/45558
9,525,564	B2	12/2016	Lee
9,531,814	B2	12/2016	Cardona-Gonzalez et al.
9,606,819	B2	3/2017	Wang et al.
9,736,556	B2	8/2017	Lingampalli
9,875,086	B1	1/2018	Anderson et al.
9,886,267	B2	2/2018	Maheshwari et al.
9,887,876	B2	2/2018	Kumar et al.
9,900,219	B2	2/2018	Huey et al.
9,948,552	B2	4/2018	Teng et al.
9,983,860	B1*	5/2018	Koty H04L 67/10
10,116,499	B2	10/2018	Kumar et al.

10,129,078	B2	11/2018	Kumar et al.
10,230,571	B2	3/2019	Rangasmy et al.
10,382,266	B1*	8/2019	Balakrishnan H04L 67/55
10,437,575	B2*	10/2019	Chen G06F 8/60
10,594,801	B2	3/2020	Cardona-Gonzalez et al.
10,764,126	B2	9/2020	Kumar et al.
11,218,363	B2	1/2022	Kumar et al.
2004/0205101	A1	10/2004	Radhakrishnan
2005/0036483	A1	2/2005	Tomisaka et al.
2006/0041641	A1	2/2006	Breiter et al.
2006/0069777	A1	3/2006	Kato et al.
2008/0016518	A1	1/2008	Yokoyama et al.
2008/0261191	A1	10/2008	Woolf et al.
2009/0164973	A1	6/2009	Barnett et al.
2010/0299437	A1	11/2010	Moore
2010/0332454	A1	12/2010	Prahlad et al.
2011/0058547	A1	3/2011	Waldrop et al.
2011/0119088	A1	5/2011	Gunn
2011/0246627	A1	10/2011	Kern
2011/0246992	A1	10/2011	Kern
2012/0096525	A1	4/2012	Bolgert et al.
2012/0151063	A1	6/2012	Yang et al.
2012/0180071	A1	7/2012	Lesandro et al.
2012/0331149	A1	12/2012	Rao
2013/0013442	A1	1/2013	Waldrop et al.
2013/0019015	A1	1/2013	Devarakonda et al.
2013/0136138	A1	5/2013	Miller et al.
2013/0166504	A1*	6/2013	Varkhedi G06F 16/275 707/610
2013/0263209	A1*	10/2013	Panuganty H04L 41/5025 709/224
2013/0283364	A1	10/2013	Chang et al.
2013/0325928	A1	12/2013	Milburn et al.
2013/0346569	A1	12/2013	Smith et al.
2014/0173594	A1	6/2014	Ng et al.
2014/0189692	A1	7/2014	Wang et al.
2014/0196028	A1*	7/2014	Macpherson G06F 9/45558 718/1
2014/0244851	A1	8/2014	Lee
2014/0289791	A1	9/2014	Acharya et al.
2014/0324911	A1	10/2014	De Lavarene et al.
2015/0121155	A1*	4/2015	Boshev H04L 41/0893 714/48
2015/0135160	A1	5/2015	Gauvin et al.
2015/0161681	A1	6/2015	Maes et al.
2015/0229645	A1	8/2015	Keith et al.
2015/0249701	A1	9/2015	Anand et al.
2016/0021197	A1	1/2016	Pogrebinsky et al.
2016/0112475	A1	4/2016	Lawson et al.
2016/0124742	A1	5/2016	Rangasamy et al.
2016/0127199	A1	5/2016	Ding et al.
2016/0127254	A1	5/2016	Kumar et al.
2016/0127454	A1	5/2016	Maheshwari et al.
2016/0308762	A1*	10/2016	Teng H04L 12/4633
2016/0337175	A1*	11/2016	Rao H04L 67/51
2016/0344590	A1	11/2016	Huey et al.
2017/0155686	A1	6/2017	Yanacek et al.
2017/0187785	A1	6/2017	Johnson et al.
2017/0244593	A1	8/2017	Rangasamy et al.
2018/0262391	A1	9/2018	Jung et al.
2020/0120166	A1	4/2020	Cardona-Gonzalez et al.
2022/0131744	A1	4/2022	Kumar et al.

FOREIGN PATENT DOCUMENTS

CN	103650456	A	3/2014
JP	2008022264	A	1/2008
JP	2012511293	A	5/2012
JP	2013504269	A	2/2013
JP	2013504270	A	2/2013
WO	2012075448	A1	6/2012

OTHER PUBLICATIONS

Notice of Intent to Grant from counterpart Application No. 11 2016 029210-3 dated Mar. 7, 2023, 1 p.

(56)

References Cited

OTHER PUBLICATIONS

“8.1.5.3 Generating a REST Controller Using Scaffolding,” Grails, retrieved from <http://grails.github.io/grails-doc/2.3.7/uide/webServices.html#/generatingRestControllers/>, Sep. 7, 2015, 18 pp.

“Bumm,” retrieved from <https://www.npmjs.com/package/bumm>, Sep. 2, 2015, 4 pp.

“Developing Front-End Microservices With Polymer Web Components and Test-Driven Development (Part 5-5) Using Microservices Technology Conversations,” retrieved from https://technologyconversations.com/2015/08/09/developing-front-end-microservices-with-polymer-web-components-and-test-driven-development-part_5-5_using_microservices technology conversations/, Aug. 9, 2015, 13 pp.

“Equinix Launches Cloud Exchange to Unlock Full Potential of Cloud Computing,” Equinix, Apr. 30, 2014, 5 pp.

“Rack-Scaffold-Master,” GitHub—matt/rack-scaffold: Automatically generate RESTful CRUD services, retrieved from <https://github.com/matt/rack-scaffold>, Aug. 28, 2014, 2 pp.

“rest—How to Use Scaffolding and RESTfulness Together in Grails 2.3—Stack Overflow,” retrieved from <http://stackoverflow.com/questions/19465421/how-to-use-scaffolding-and-restfulness-together-in-Grails-2.3>, Oct. 19, 2013, 5 pp.

“Step 3 Use a Generator to Scaffold Out your App,” Yeoman, retrieved from <http://yeoman.io/codelab/scaffold-app.html>, Sep. 2, 2015, 6 pp.

Abrams et al., “An Emergent Micro-Services Approach to Digital Curation Infrastructure,” The International Journal of Digital Curation, vol. 5, No. 1, Jun. 22, 2010, 15 pp.

Banikazemi et al., “Meridian: an SON platform for cloud network services”, IEEE Communications Magazine, IEEE Service Center, vol. 51, No. 2, Piscataway, US, Feb. 1, 2013, pp. 120-127.

Cortis, “REST and Scaffolding,” retrieved from <http://www.slideshare.net/kcortis/rails-girlsgalwayestscaffoldingkeith>, Jul. 5, 2014, 7 pp.

Dillon, “How to Write a Ruby and Rails 3 Rest API,” Squarism, retrieved from <http://squarism.com/2011/04/01/how-to-write-a-ruby-rails-3-rest-api/>, Apr. 1, 2011, 19 pp.

Equinix HD “Episode 6: How to join the Equinix Cloud Exchange,” Equinix Videos, YouTube, Jul. 14, 2014, 1 pp. Retrieved from the Internet: <https://www.youtube.com/watch?v=FnnTRssh40>.

Equinixvideos: “Equinix HD 1 Episode 1: Performance Hub w/ Anirvan Das”, YouTube, Mar. 19, 2014 (Mar. 19, 2014), p. 1 pp., XP054980316, Retrieved from the Internet: URL:<https://www.youtube.com/watch?v=110aDEv6M7k> [retrieved on Mar. 19, 2020].

Equinixvideos: “Equinix HD 1 Episode 4: Equinix Cloud Exchange w/ Bill Long”, youtube, Apr. 30, 2014 (Apr. 30, 2014), p. 1 pp., XP054978199, Retrieved from the Internet: URL:<https://www.youtube.com/watch?v=iDSuvOil8LA> [retrieved on Mar. 22, 2018].

Examination Report from counterpart Australian Application No. 2015338902, dated Nov. 1, 2017, 2 pp.

Examination Report from counterpart Australian Application No. 2019200821, dated Nov. 21, 2019, 2 pp.

Examination Report from counterpart European Application No. 15794014.9, dated Apr. 15, 2018, 7 pp.

Examination Report from counterpart European Application No. 19205162.1, dated Apr. 6, 2021, 10 pp.

Extended European Search Report of European Application No. 19205162.1 dated Apr. 7, 2020, 14 pp.

First Examination Report from counterpart Australian Patent Application No. 2020203877, dated Mar. 16, 2021, 4 pp.

First Office Action and Search Report, and translation thereof, from counterpart Chinese Application No. 2015800323212, dated Dec. 25, 2018, 11 pp.

Genuitec, “Scaffolding a Spring MVC Application,” retrieved from <https://www.genuitec.com/products/myeclipse/learning-center/spring/spring-3-0-mvc-scaffolding/>, Sep. 2, 2015, 16 pp.

International Preliminary Report on Patentability from International Application No. PCT/US2015/058500, dated Feb. 8, 2017, 7 pp.

International Search Report and Written Opinion from International Application No. PCT/US2015/058500, dated Feb. 11, 2016, 20 pp.

Invitation to Respond to Written Opinion from Singaporean Application No. 10202004184R, dated Jul. 5, 2022, 8 pp.

Jazayeri et al., “Some Trends in Web Application Development,” Future of Software Engineering (FOSE ’07), Jun. 2007, 14 pp.

Kovacevic, “RESTful Admin Namespaced Controller Using Scaffolding,” retrieved from <http://icebergist.com/posts/restful-admin-namespaced-controller-using-scaffolding/>, Sep. 17, 2008, 4 pp.

Namiot et al., “On Micro-services Architecture,” International Journal of Open Information Technologies ISSN: 2307-8162 vol. 2, No. 9, Aug. 20, 2014, 4 pp.

Notice of Acceptance dated Jun. 18, 2018, from counterpart Australian Application No. 2015338902, 3 pp.

Notice of Acceptance from counterpart Australian Patent Application No. 2018236712, dated Oct. 25, 2018, 3 pp.

Notice of Allowance from counterpart Canadian Application No. 3,146,289, dated Jun. 28, 2022, 1 pp.

Notice of Intent to Grant from counterpart Canadian Application No. 2,951,939 dated Oct. 12, 2022, 1 pp.

Office Action from counterpart Canadian Application No. 2,951,939 dated Oct. 23, 2017, 4 pp.

Office Action from counterpart Canadian Application No. 2,951,939 dated Sep. 10, 2021, 4 pp.

Office Action from counterpart Canadian Application No. 2,951,939, dated Oct. 3, 2018, 6 pp.

Office Action from counterpart Canadian Application No. 2,951,939, dated Sep. 30, 2019, 3 pp.

Office Action from U.S. Appl. No. 17/646,375 dated Sep. 23, 2022, 5 pp.

Okawara, “Equinix, linking multiple cloud services Cloud Exchange,” Equinix, Jun. 4, 2014, 3 pp.

Prosecution History from U.S. Appl. No. 14/927,306, dated Sep. 5, 2017 through Apr. 12, 2018, 64 pp.

Prosecution History from U.S. Appl. No. 14/927,315, dated Mar. 14, 2018 through Oct. 24, 2018, 44 pp.

Prosecution History from U.S. Appl. No. 14/927,451, dated Jun. 22, 2017 through Nov. 1, 2017, 31 pp.

Prosecution History from U.S. Appl. No. 15/395,101, dated Jan. 27, 2017 through Oct. 23, 2017, 57 pp.

Prosecution History from U.S. Appl. No. 15/887,165, dated Apr. 13, 2018 through Jul. 23, 2018, 33 pp.

Prosecution History from U.S. Appl. No. 16/172,501, dated Feb. 26, 2019 through May 15, 2020, 40 pp.

Prosecution History from U.S. Appl. No. 17/007,929, dated Aug. 17, 2021 through Dec. 1, 2021, 12 pp.

Reply to Written Opinion dated Feb. 11, 2016, filed Aug. 30, 2016 from counterpart International Application No. PCT/US2015/058500, 21 pgs.

Response to Canadian Office Action dated Oct. 23, 2017, from counterpart Canadian application No. 2,951,939, filed Apr. 20, 2018, 19 pp.

Response to Communication pursuant to Rules 70(2) and 70a(2) dated May 27, 2020, from counterpart European Application No. 19205162.1, filed Nov. 20, 2020, 204 pp.

Response to Examination Report dated Apr. 6, 2021, from counterpart European Application No. 19205162.1, filed Oct. 15, 2021, 8 pp.

Response to Examination Report dated Oct. 5, 2018, from counterpart European Application No. 15794014.9, filed Oct. 5, 2018, 20 pp.

Response to Notification of Reasons for Rejection dated Apr. 24, 2018, from counterpart Japanese application No. 2016-573992, filed Nov. 26, 2018, 17 pp.

Response to Office Action dated Sep. 10, 2021, from counterpart Canadian Application No. 2,951,939 filed Jan. 20, 2022, 12 pp.

Response to Office Action filed in Canadian Application No. 2,951,939 dated Mar. 13, 2020, 10 pp.

Response to Written Opinion dated Jul. 5, 2022, from counterpart Singaporean Application No. 10202004184R filed Nov. 29, 2022, 19 pp.

Rosen et al., “BGP/MPLS IP Virtual Private Networks (VPNs),” RFC 4364, Feb. 2006, Internet Engineering Task Force(IETF) Network Working Group, 47 pp.

(56)

References Cited

OTHER PUBLICATIONS

Ruby et al., "Agile Web Development with Rails 5.1," The Pragmatic Bookshelf, Nov. 2017, 10 pp.

Scotfield, "Rails 3 Generators Scaffolding," retrieved from <https://www.viget.com/articles/rails-3-generatorscaffolding>, Mar. 2, 2010, 3 pp.

Second Written Opinion of International Application No. PCT/US2015/058500, dated Oct. 10, 2016, 6 pp.

Stafford, "Building a Microservices-based REST API with RestExpress, Java EE, and MongoDB Part 2, Programmatic Ponderings," retrieved from <http://programmaticponderings.worldpress.com/2015/05/31/building-amicroservices-based-rest-api-with-restexpress-jhava-ee-and-mongodb-part-2/>, May 31, 2015, 20 pp.

Summons to Attend Oral Proceedings Issued in EP Application No. 15794014.9 dated May 21, 2019, 11 pp.

Summons to Attend Oral Proceedings Pursuant to Rule 115(1) EPC from counterpart European Application No. 19205162.1 dated May 27, 2022, 13 pp.

The Notification of Reason for Rejection, and translation thereof, from counterpart Japanese Application No. 2016-573992, dated Apr. 24, 2018, 9 pp.

Thomas, "REST, Scaffolding, and Data Models Ruby on Rails," retrieved from http://jacobjthomas.com/rubyonrails/rest_scaffolding_user_micropost_data_model/, Aug. 22, 2013, 8 pp.

U.S. Appl. No. 61/239,997, by Sukwan Youn, filed Sep. 4, 2009.

U.S. Appl. No. 61/285,371, by Sukwan Youn, filed Dec. 10, 2009.

U.S. Appl. No. 61/323,066, by Sukwan Youn, filed Apr. 12, 2010.

U.S. Appl. No. 62/216,804, by Mohan Rao G. Lingampalli, filed Sep. 10, 2015.

Wintermeyer, "5.2. Generating a Scaffold," retrieved from http://www.xyzpub.com/en/ruby-on-rails/3.21_scaffold_anlegen.html, Sep. 2, 2015, 18 pp.

* cited by examiner

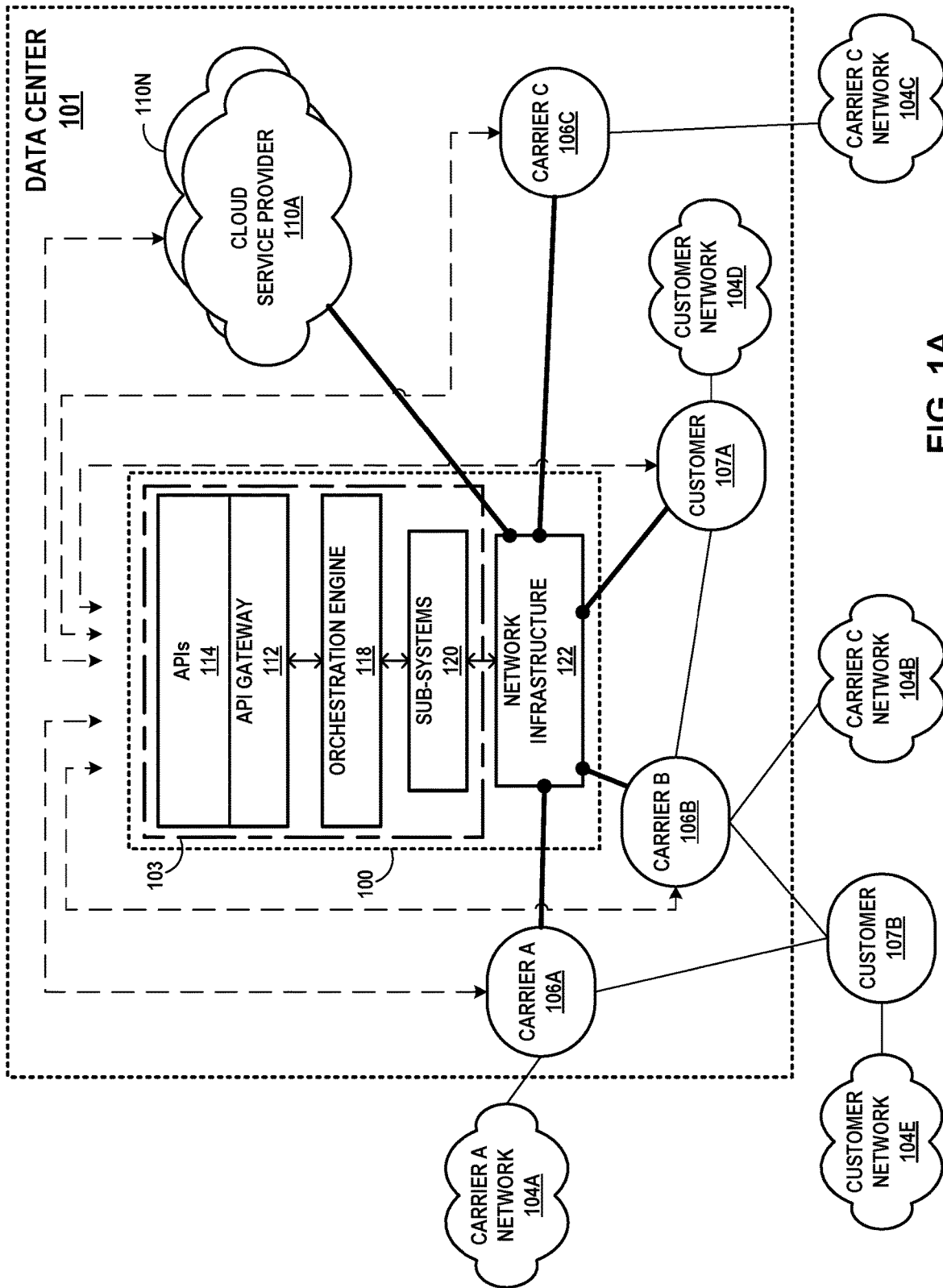

FIG. 1A

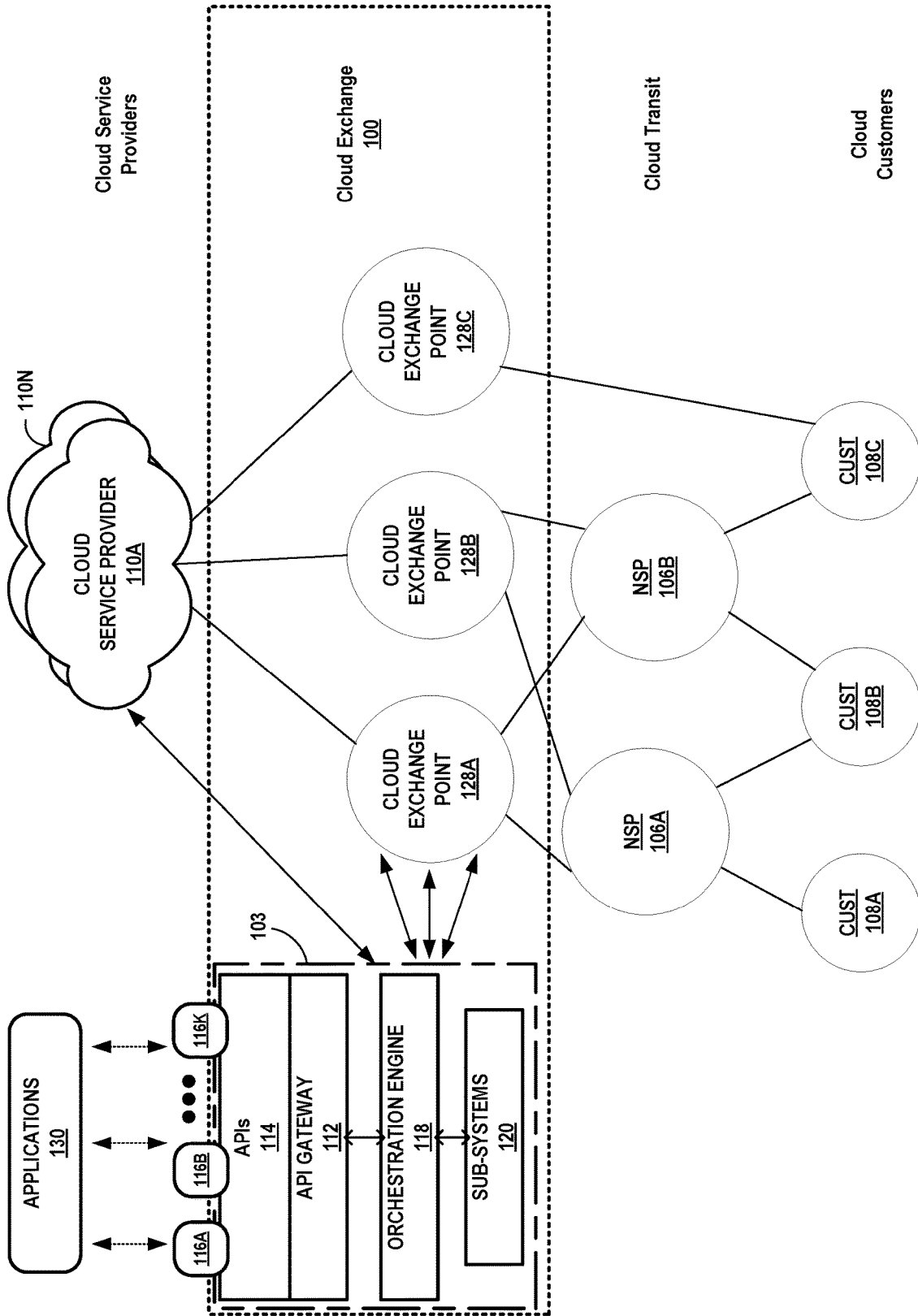

FIG. 1B

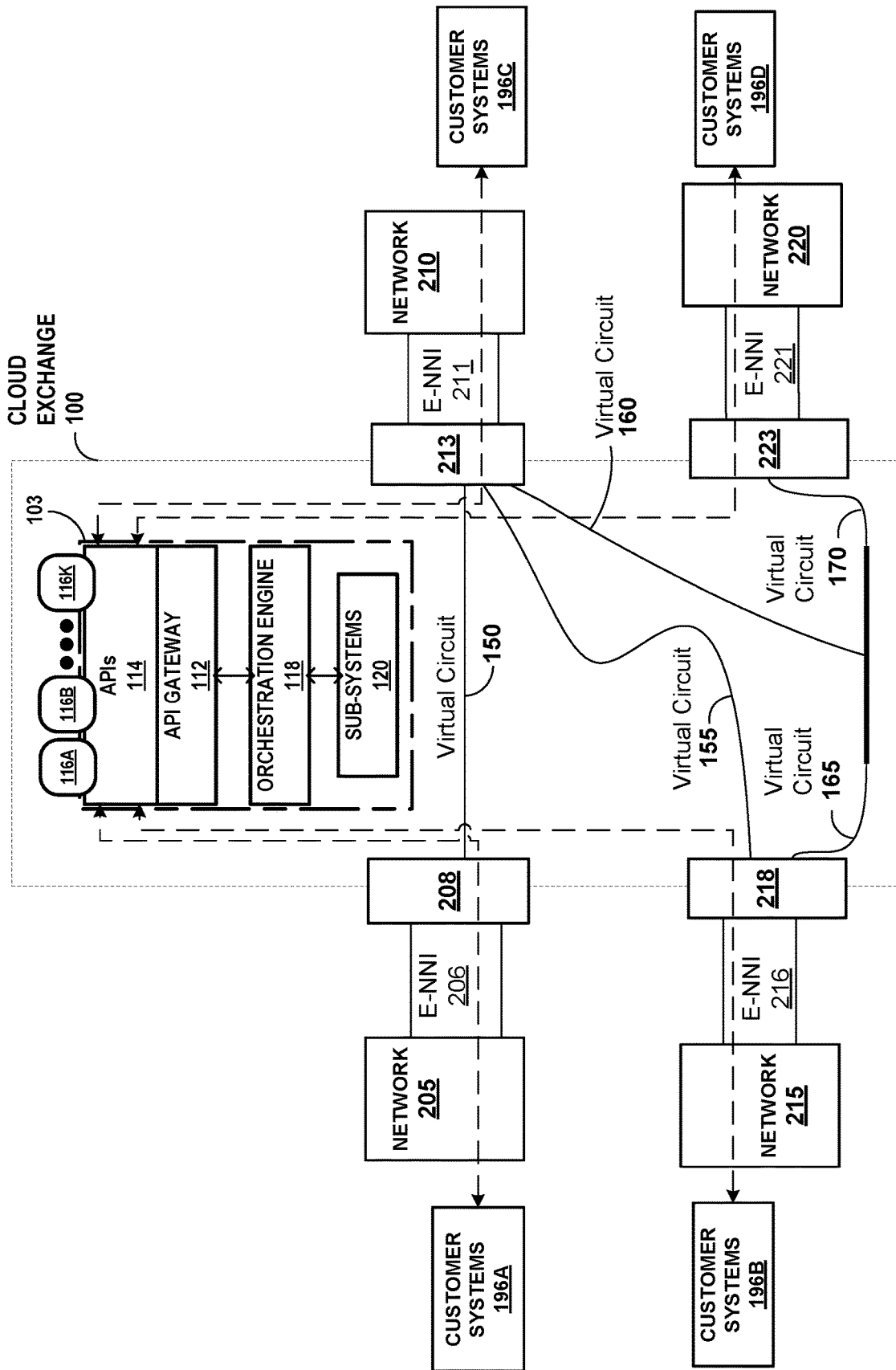

FIG. 1C

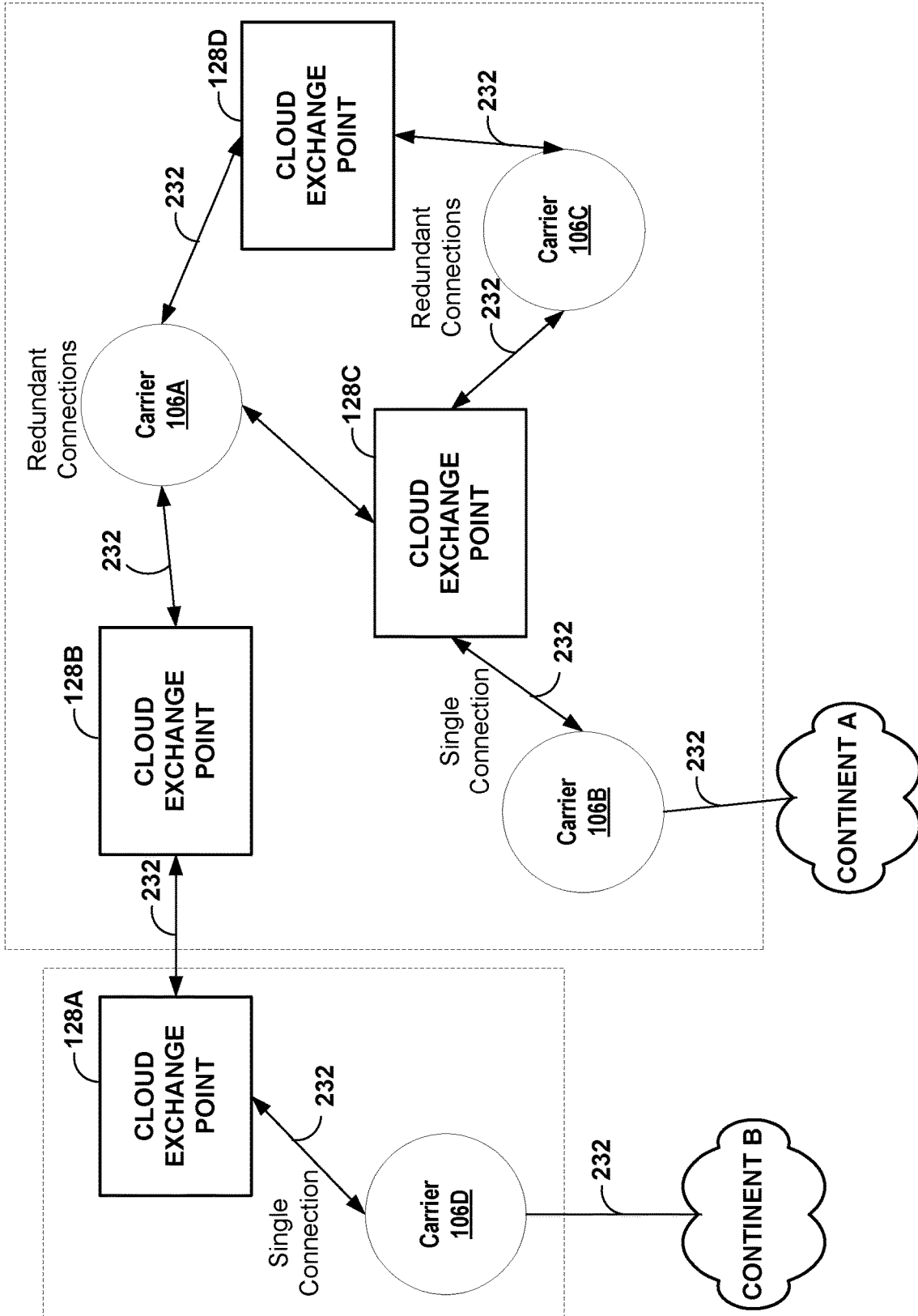

FIG. 1D

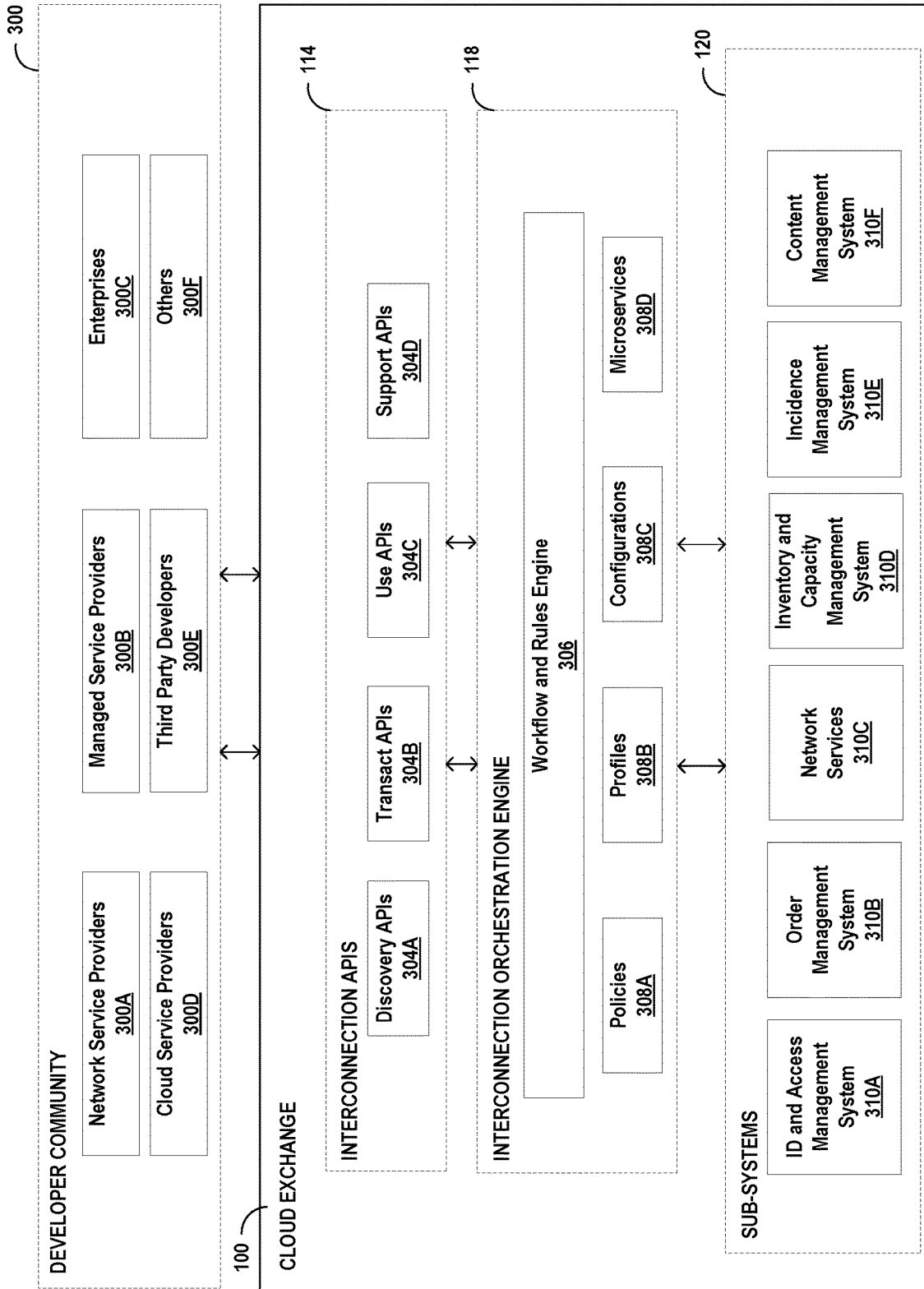

FIG. 2

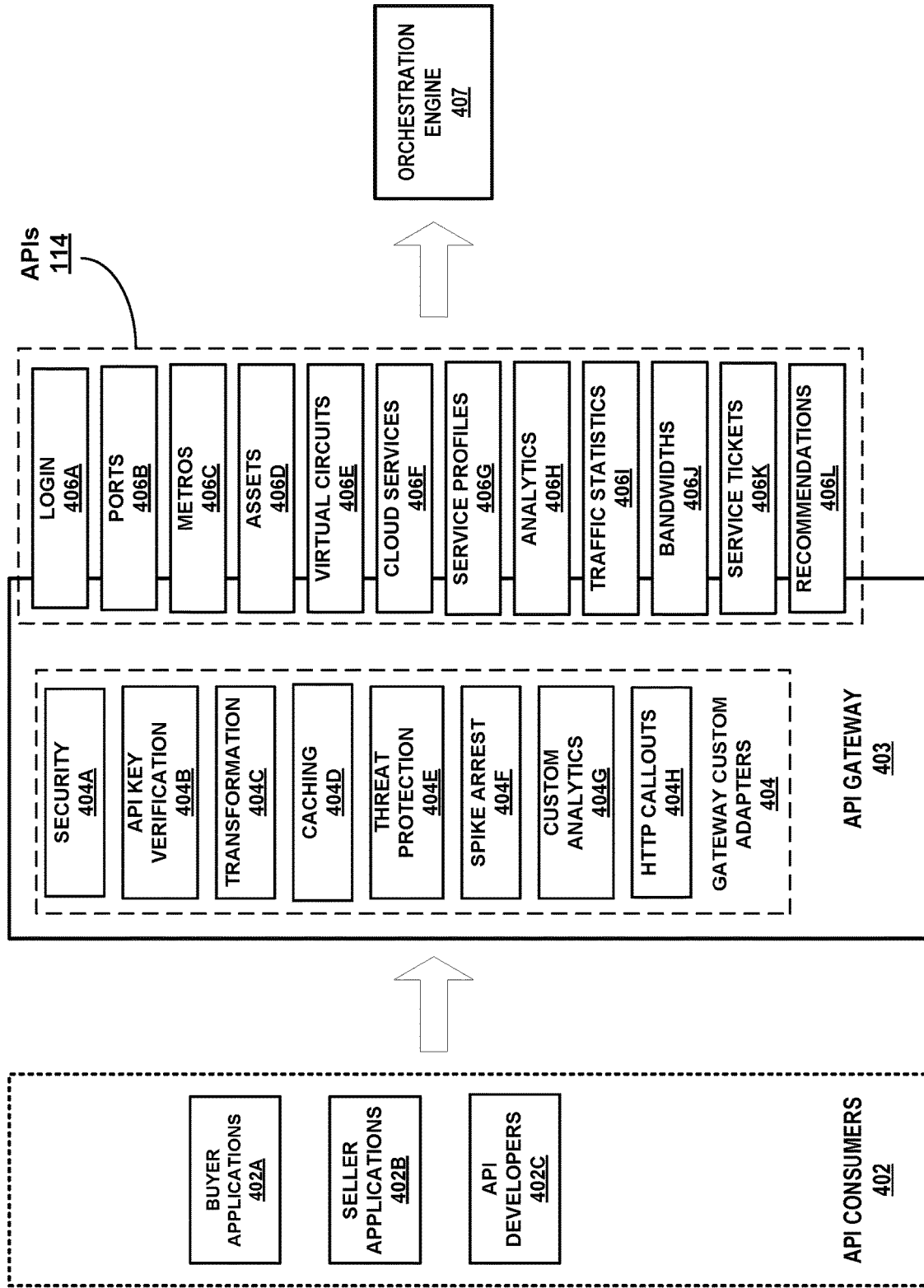

FIG. 3A

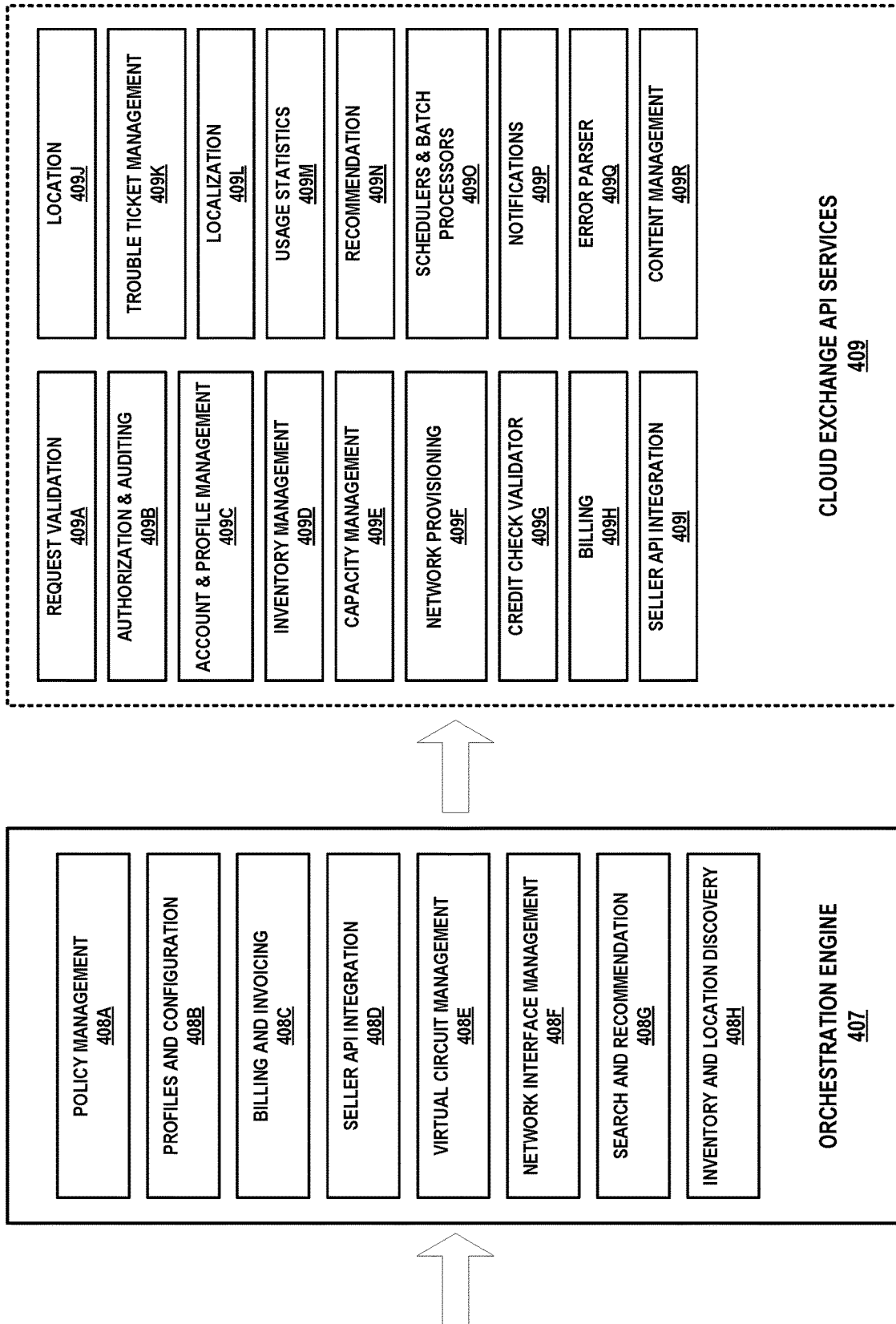

FIG. 3B

103

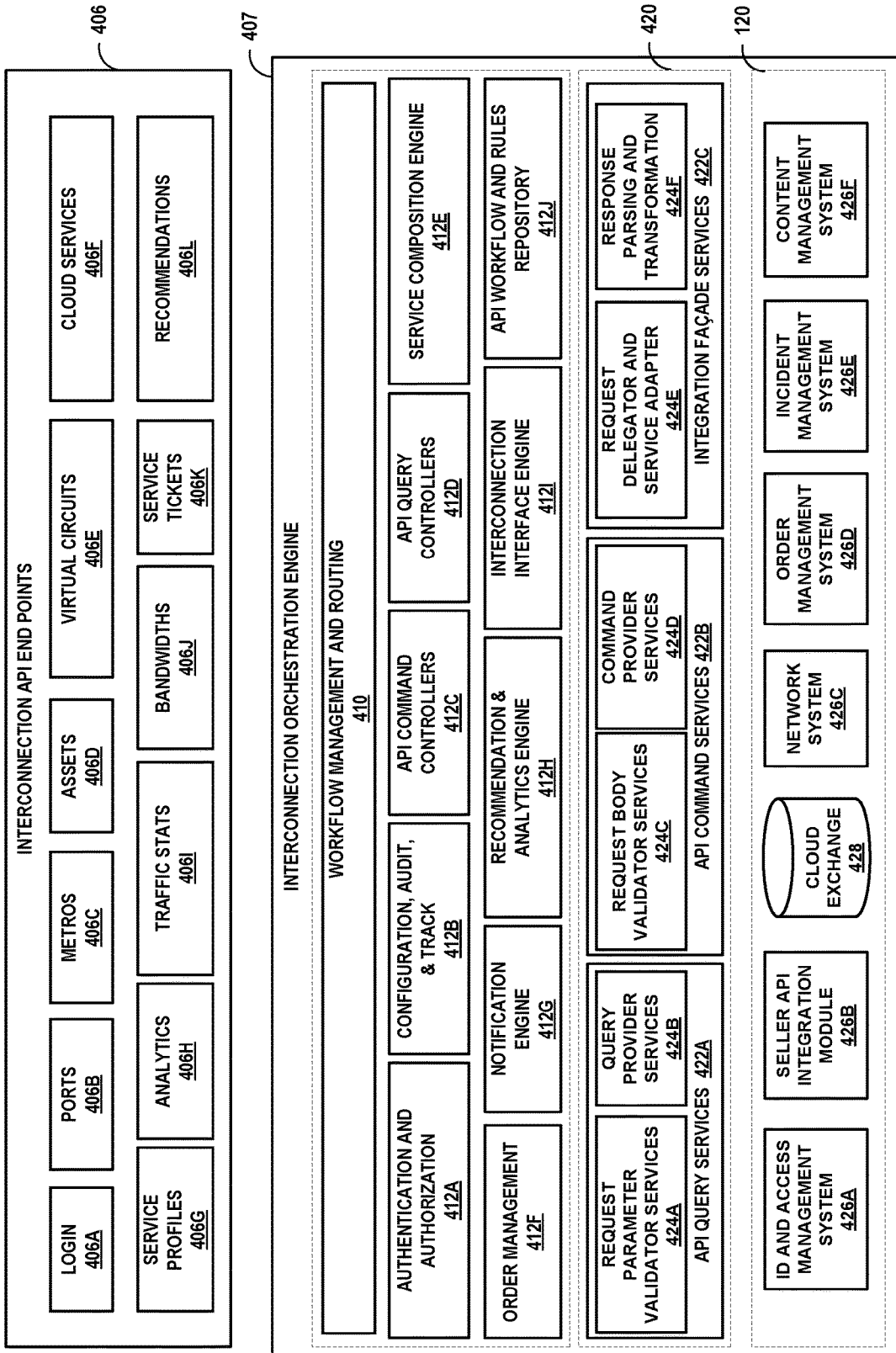

FIG. 4

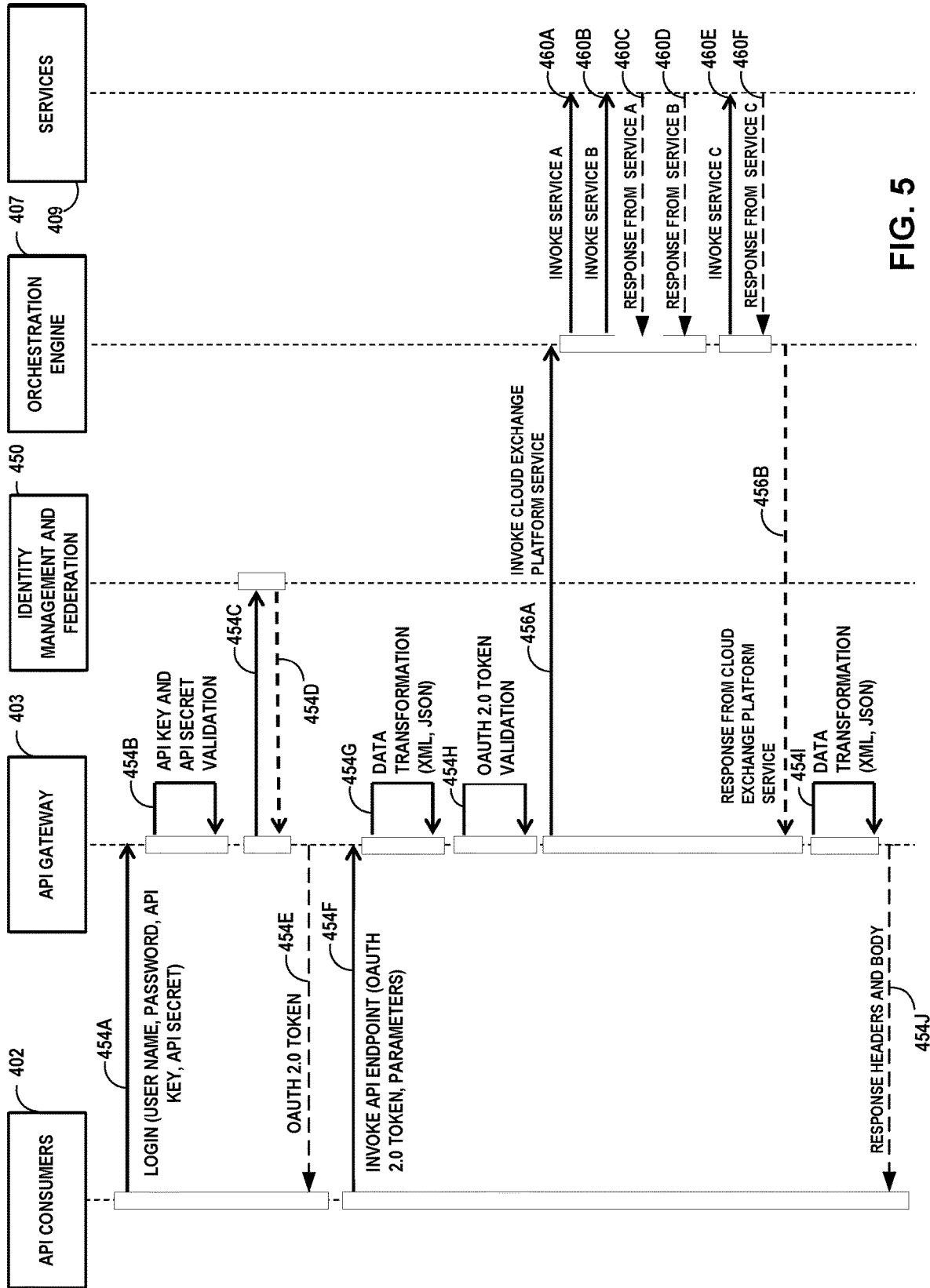

FIG. 5

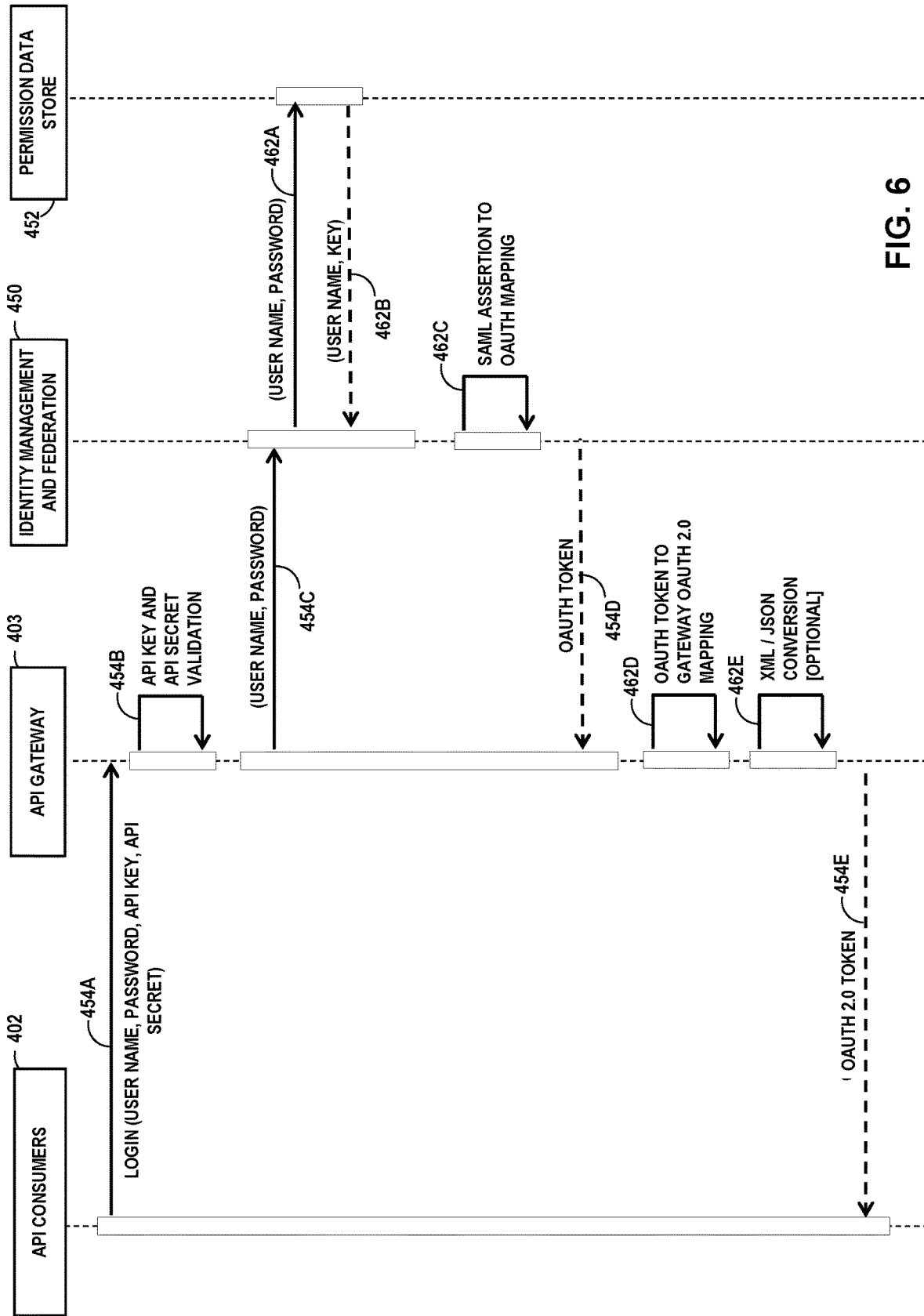

FIG. 6

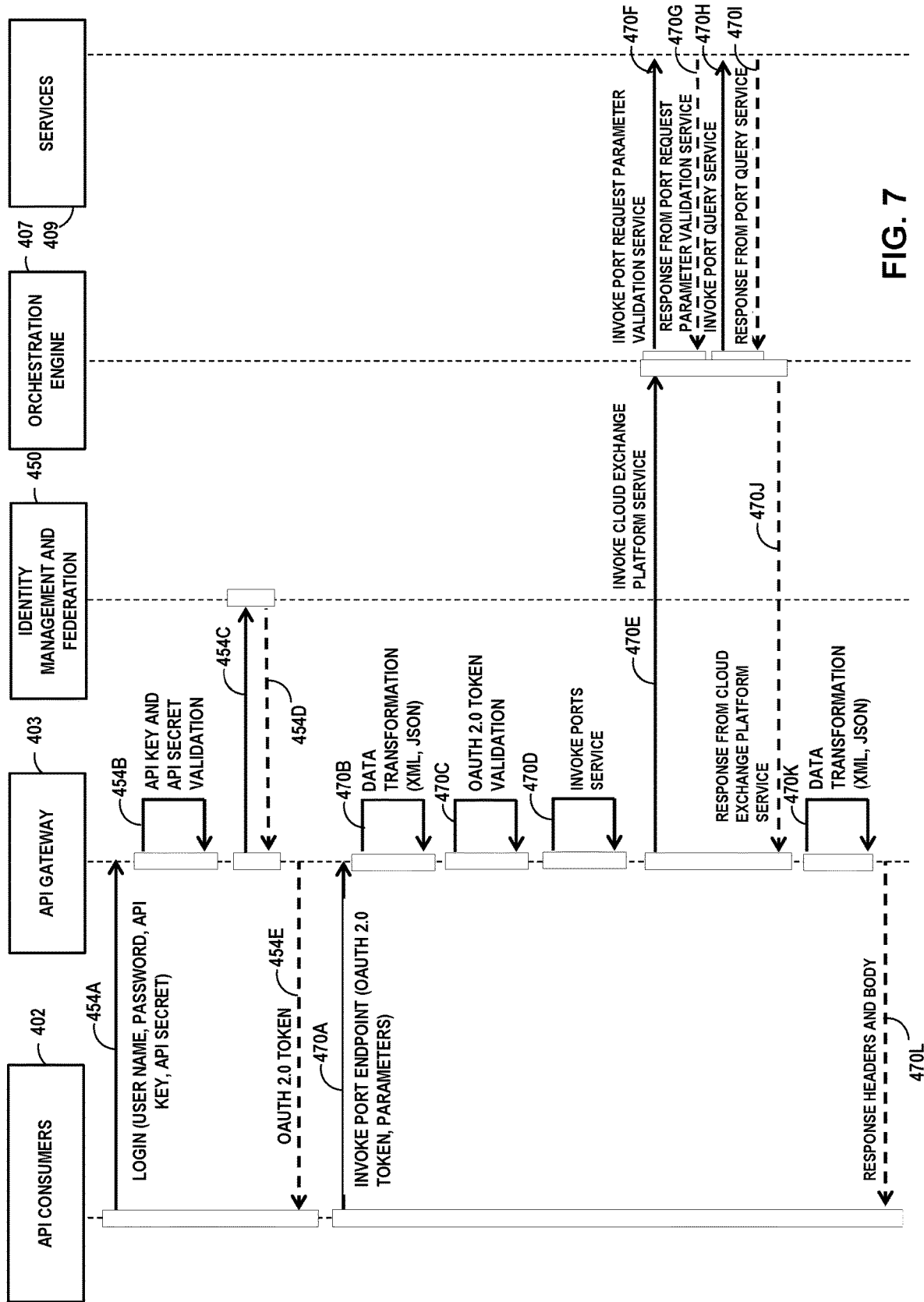

FIG. 7

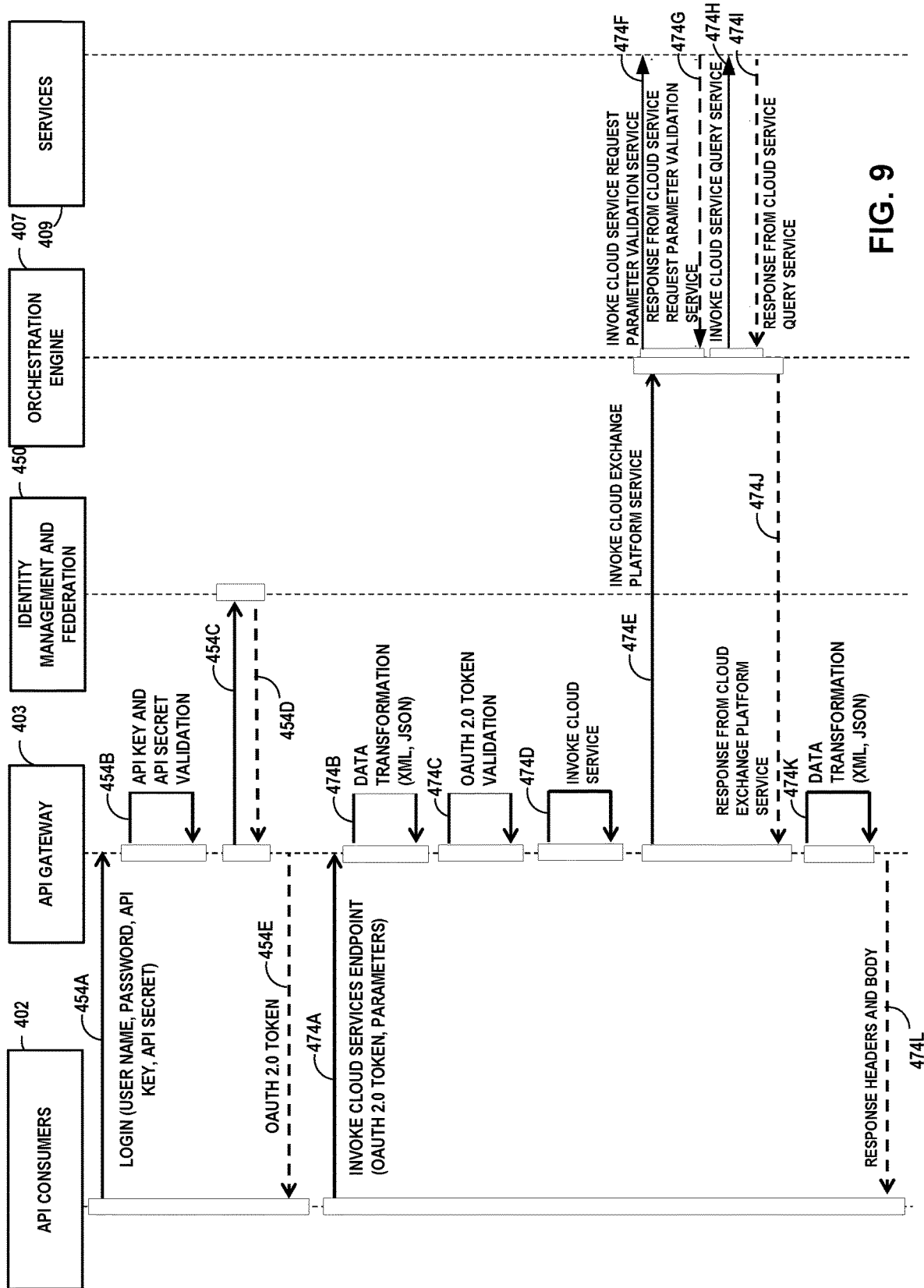

FIG. 9

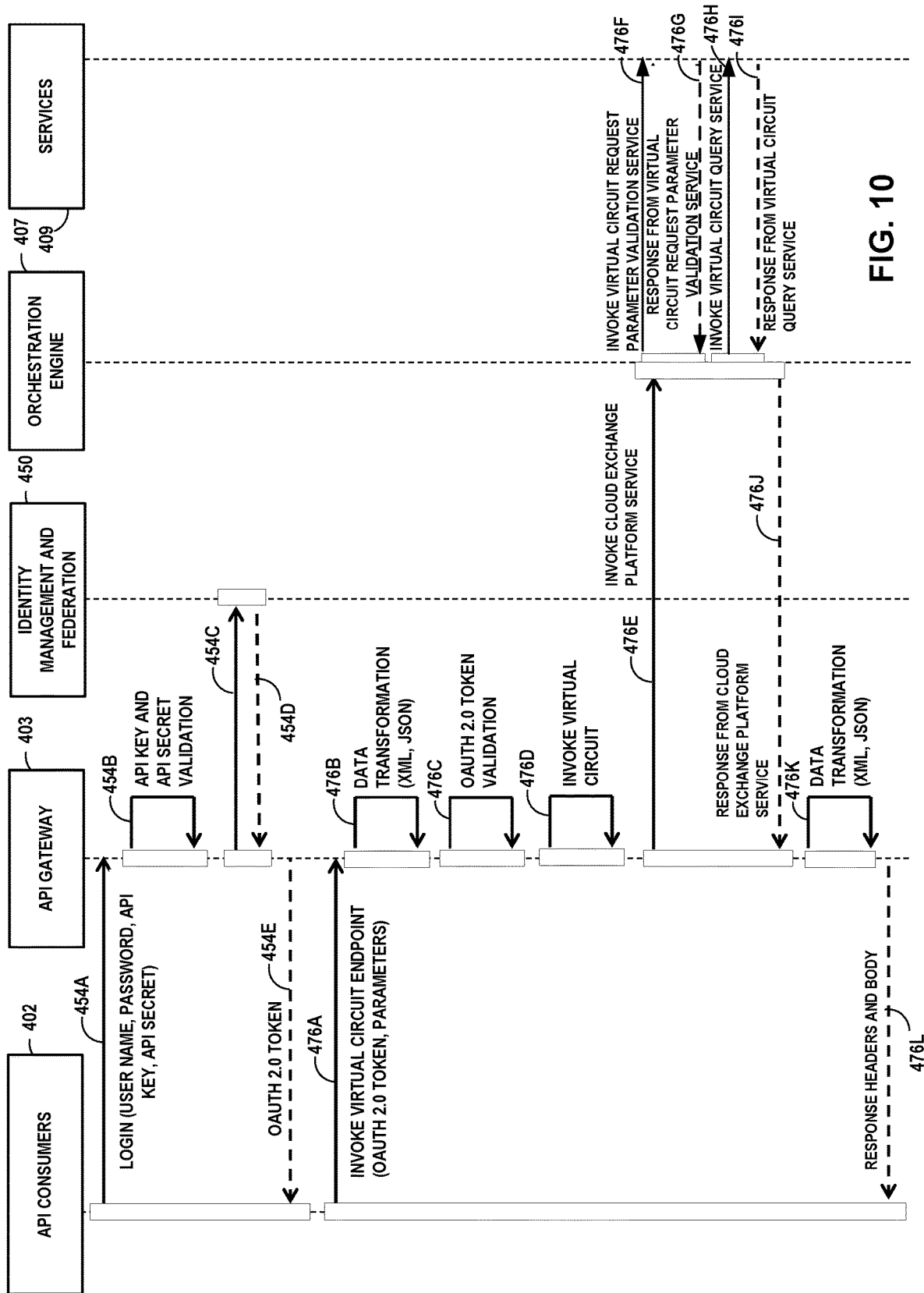

FIG. 10

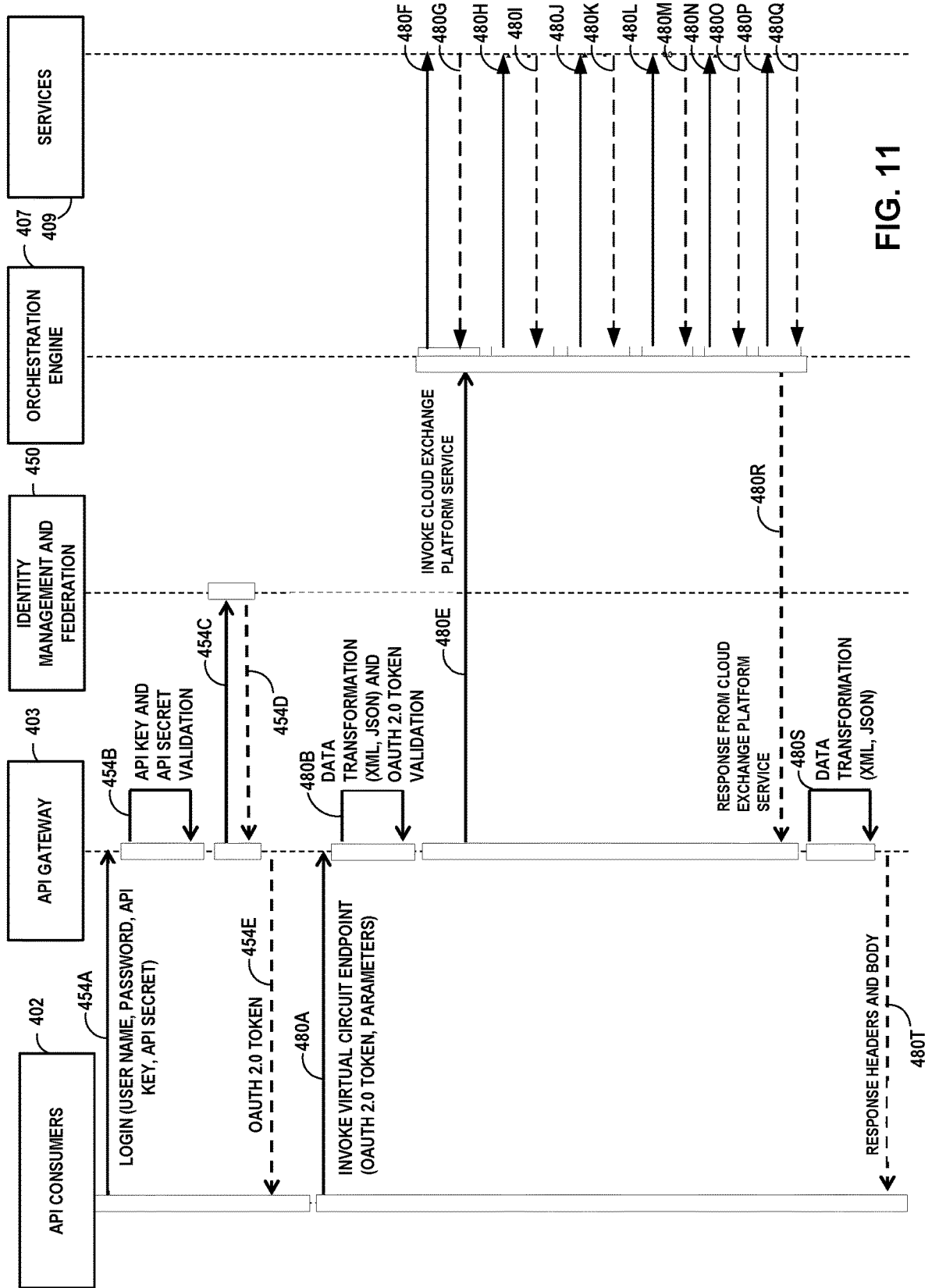

FIG. 11

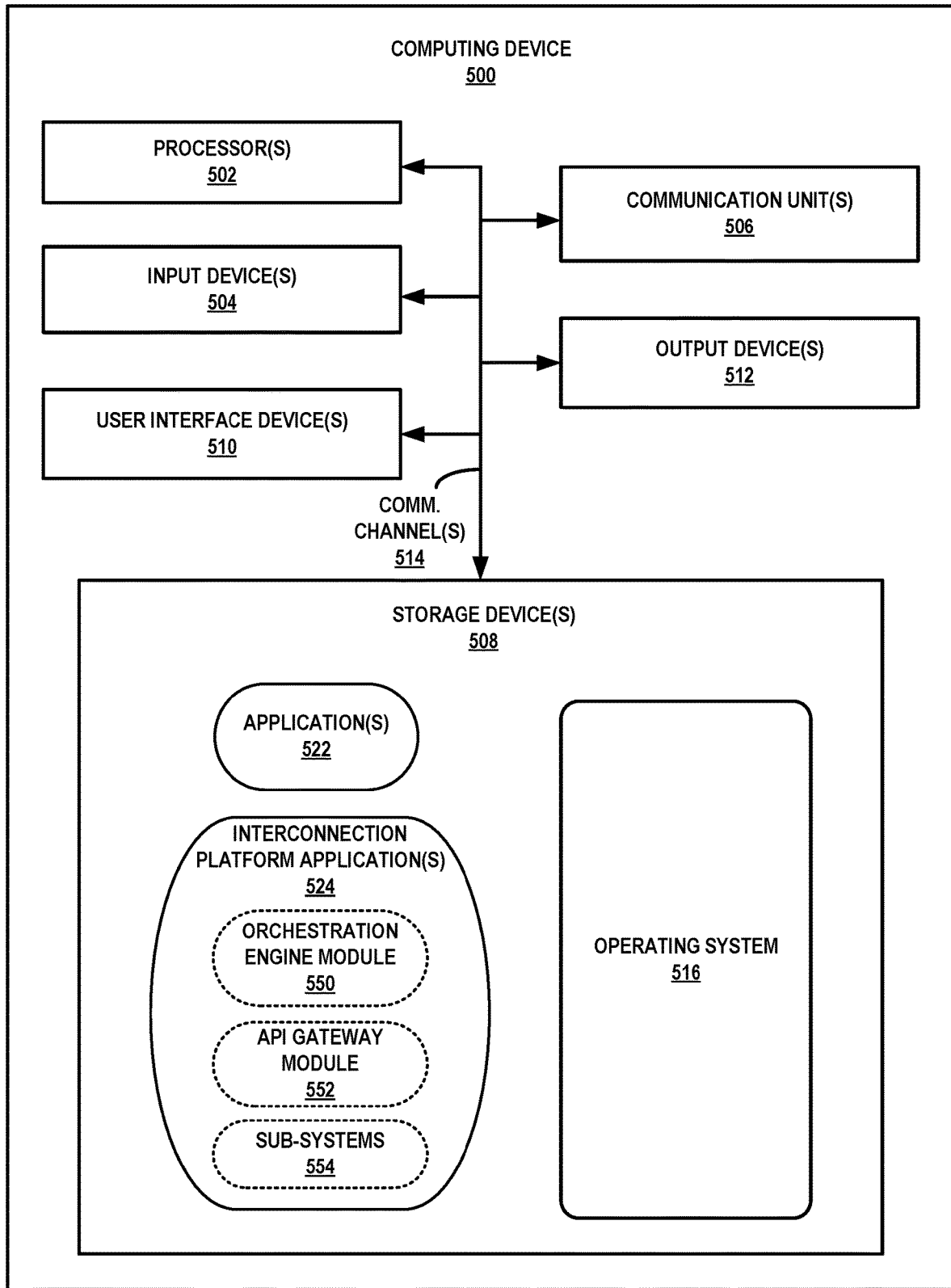

FIG. 12

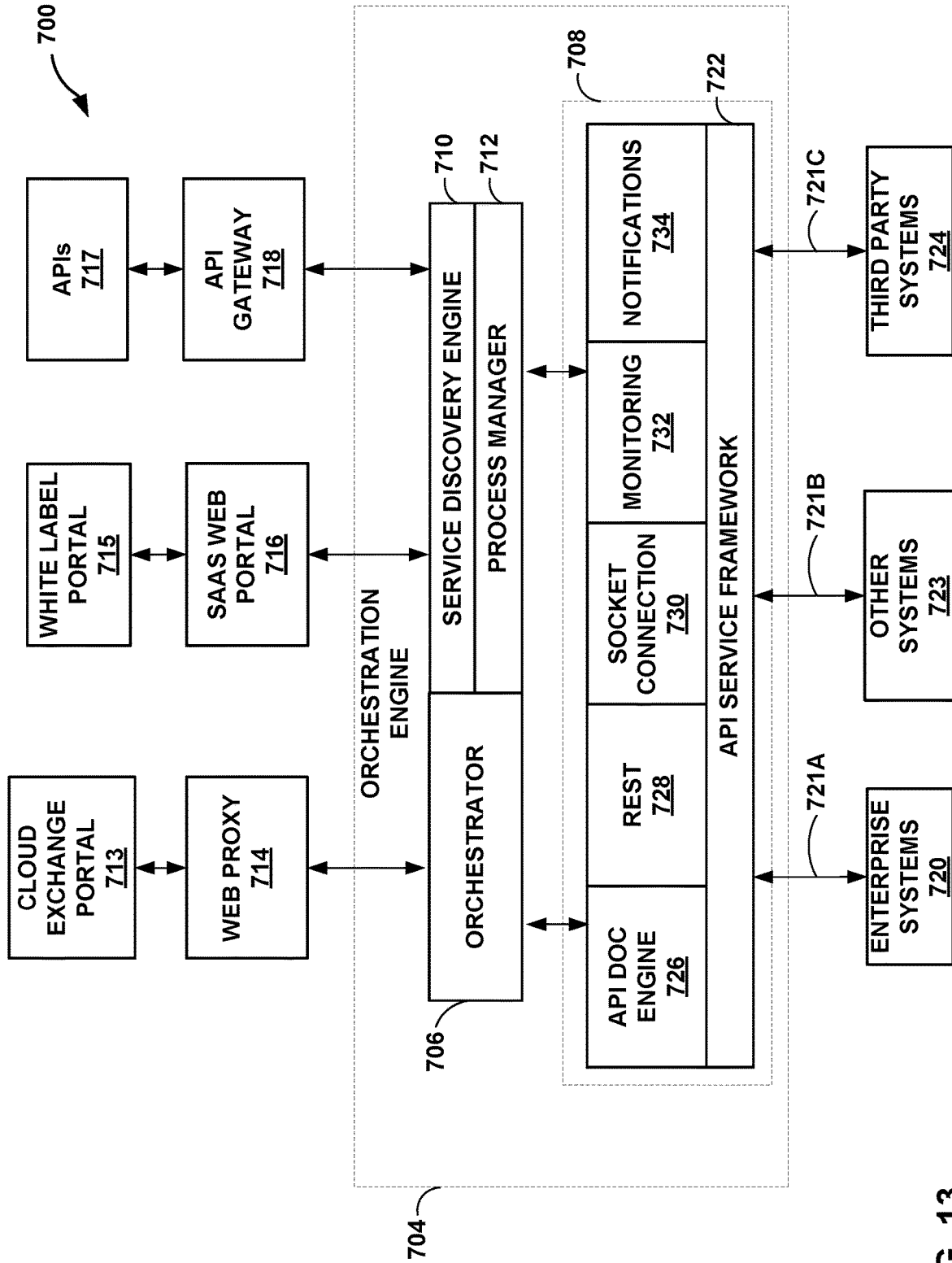

FIG. 13

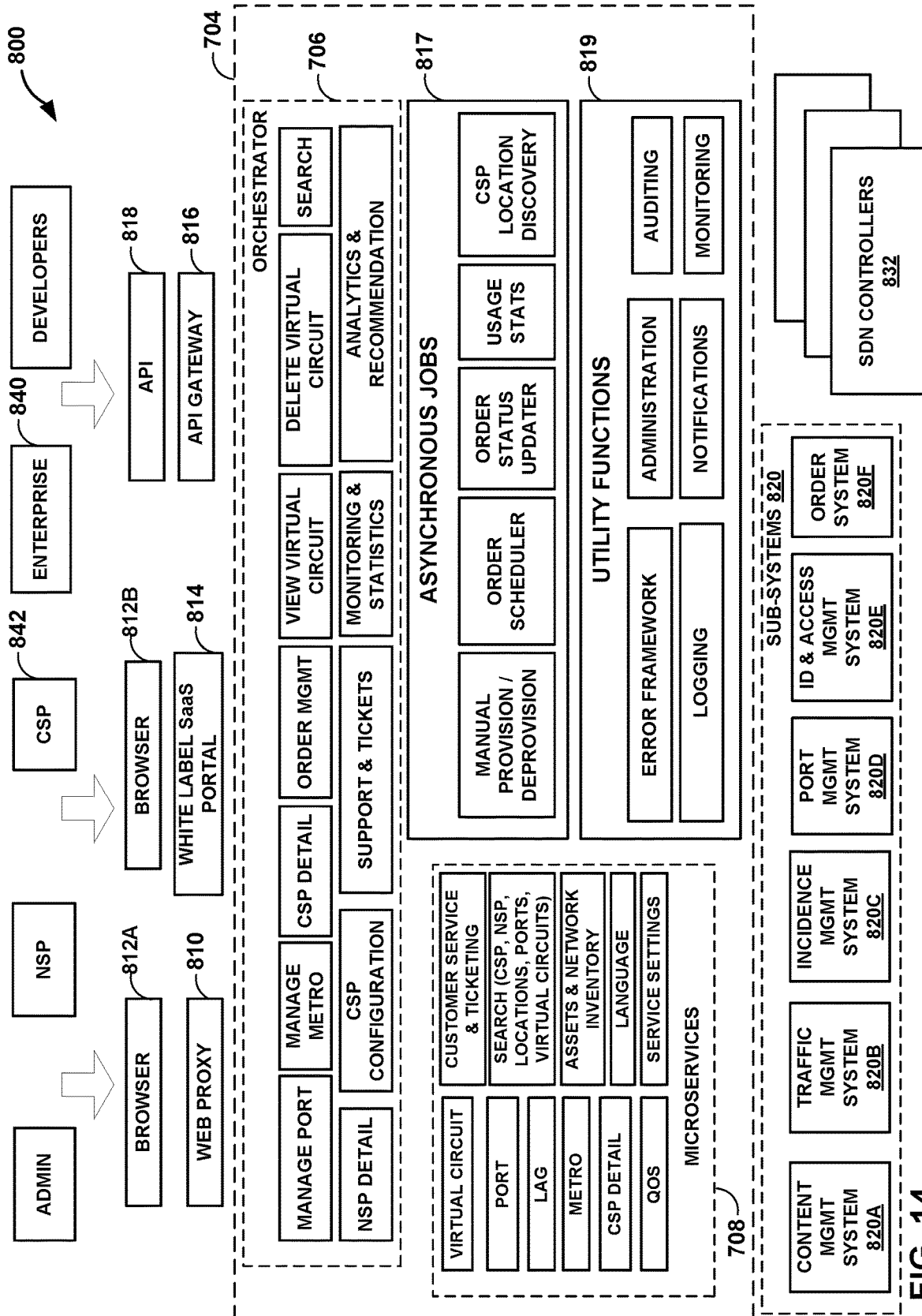

FIG. 14

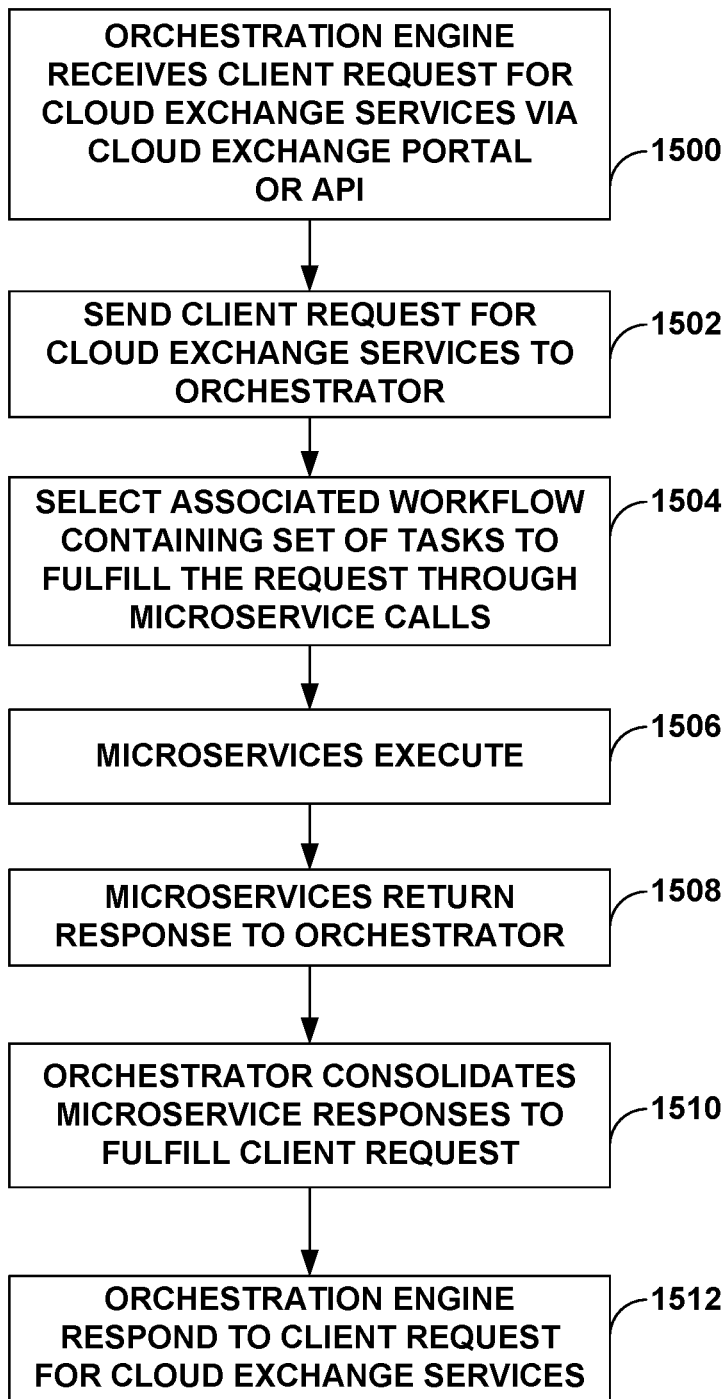

FIG. 15

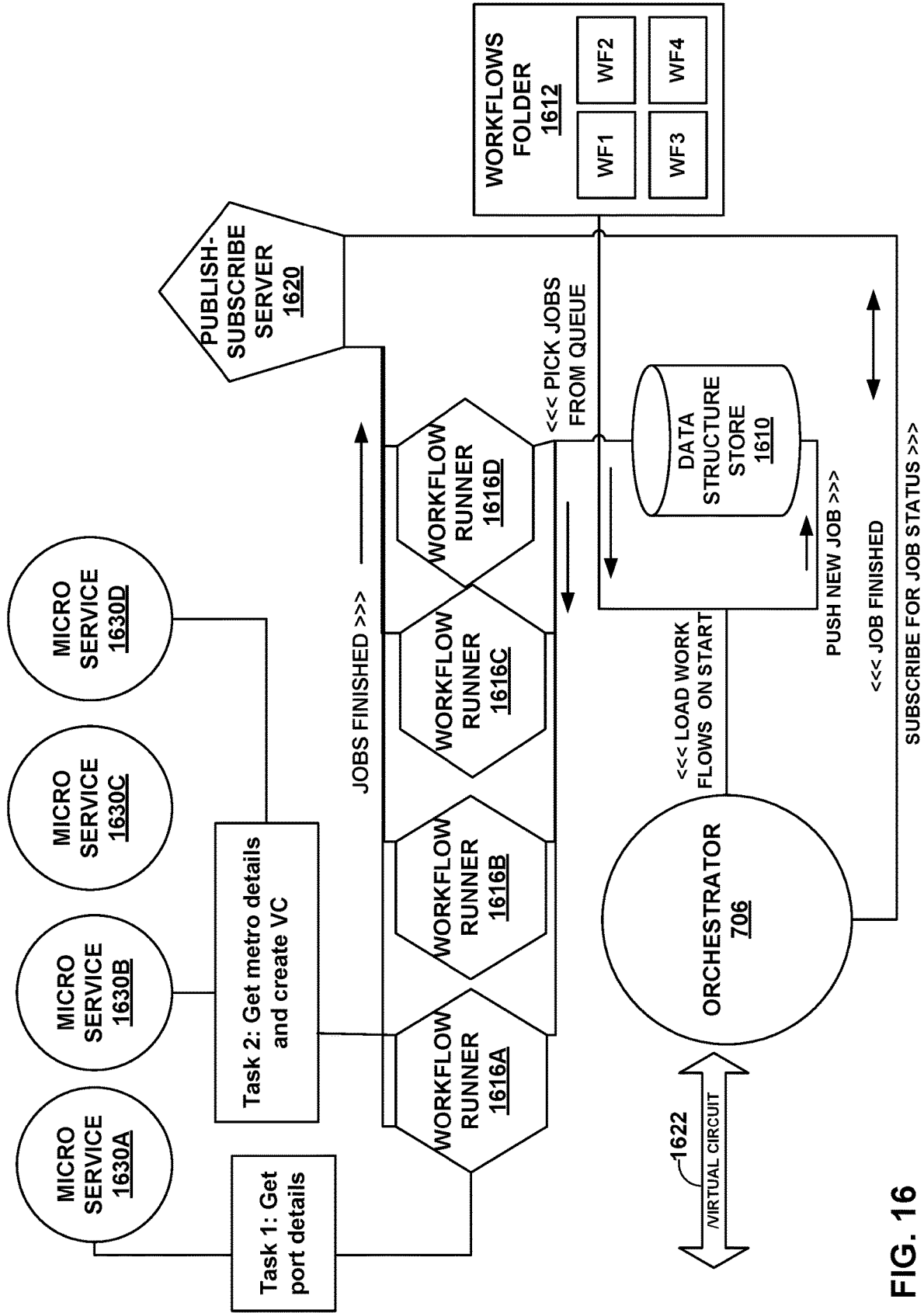

FIG. 16

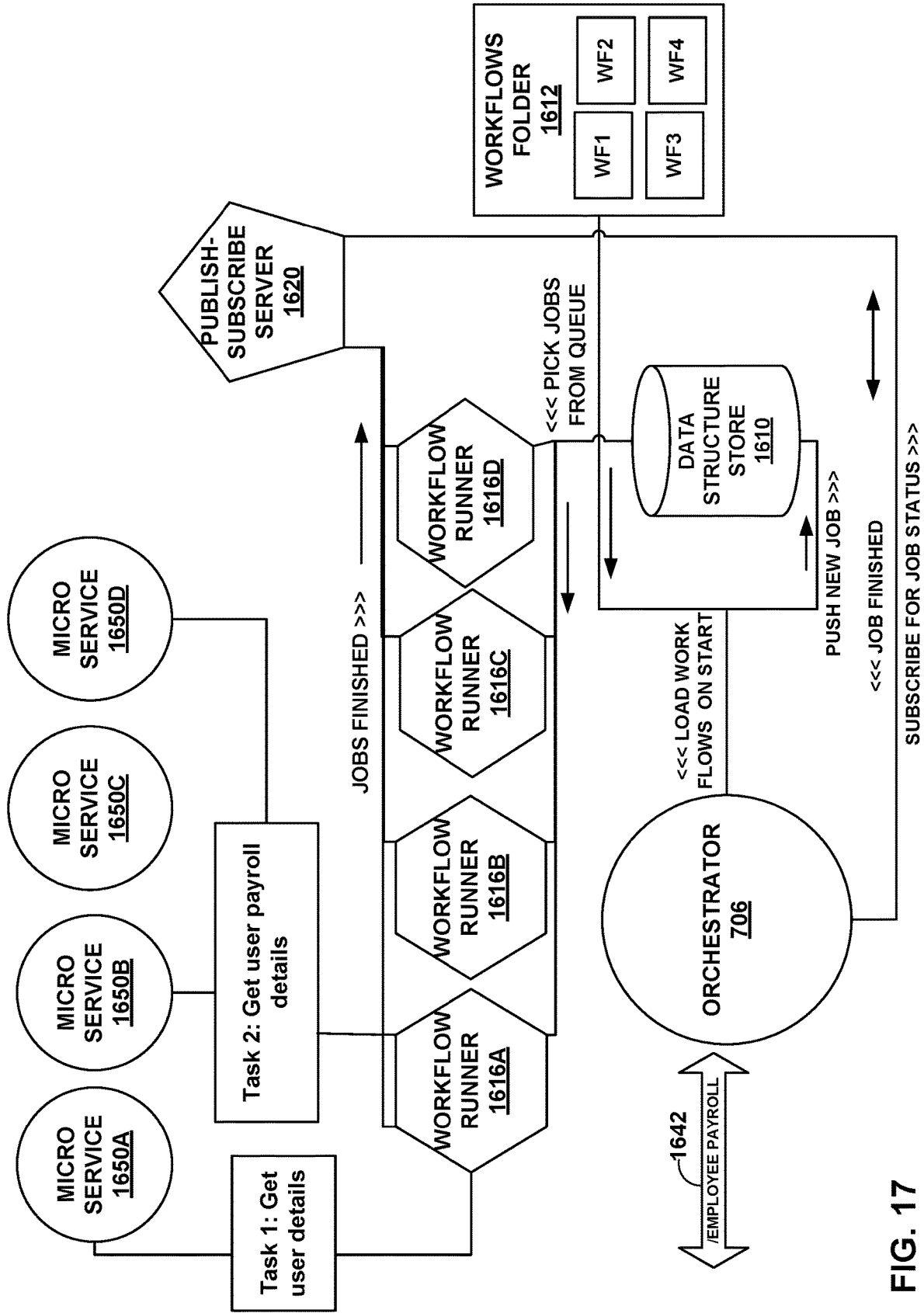

FIG. 17

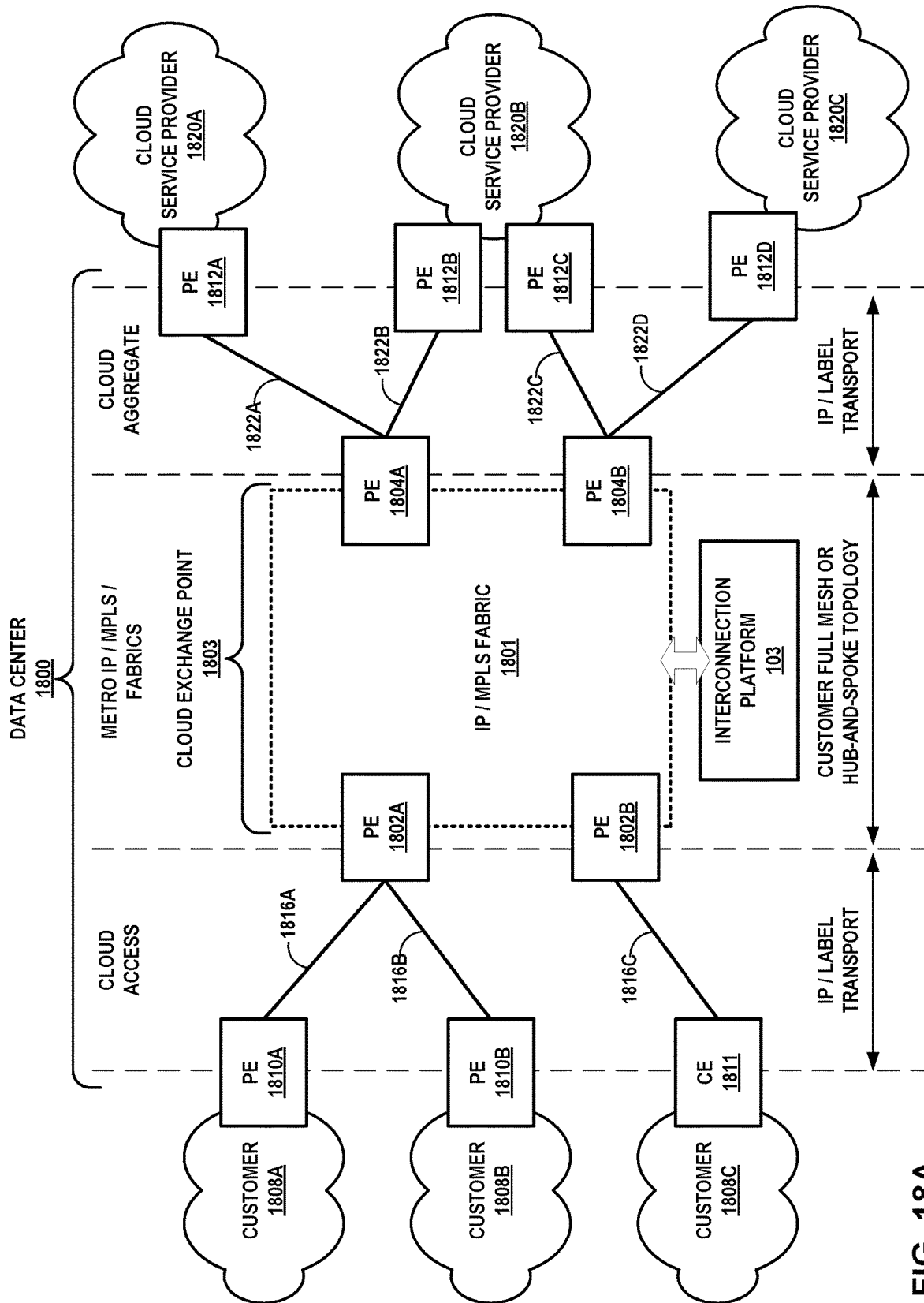

FIG. 18A

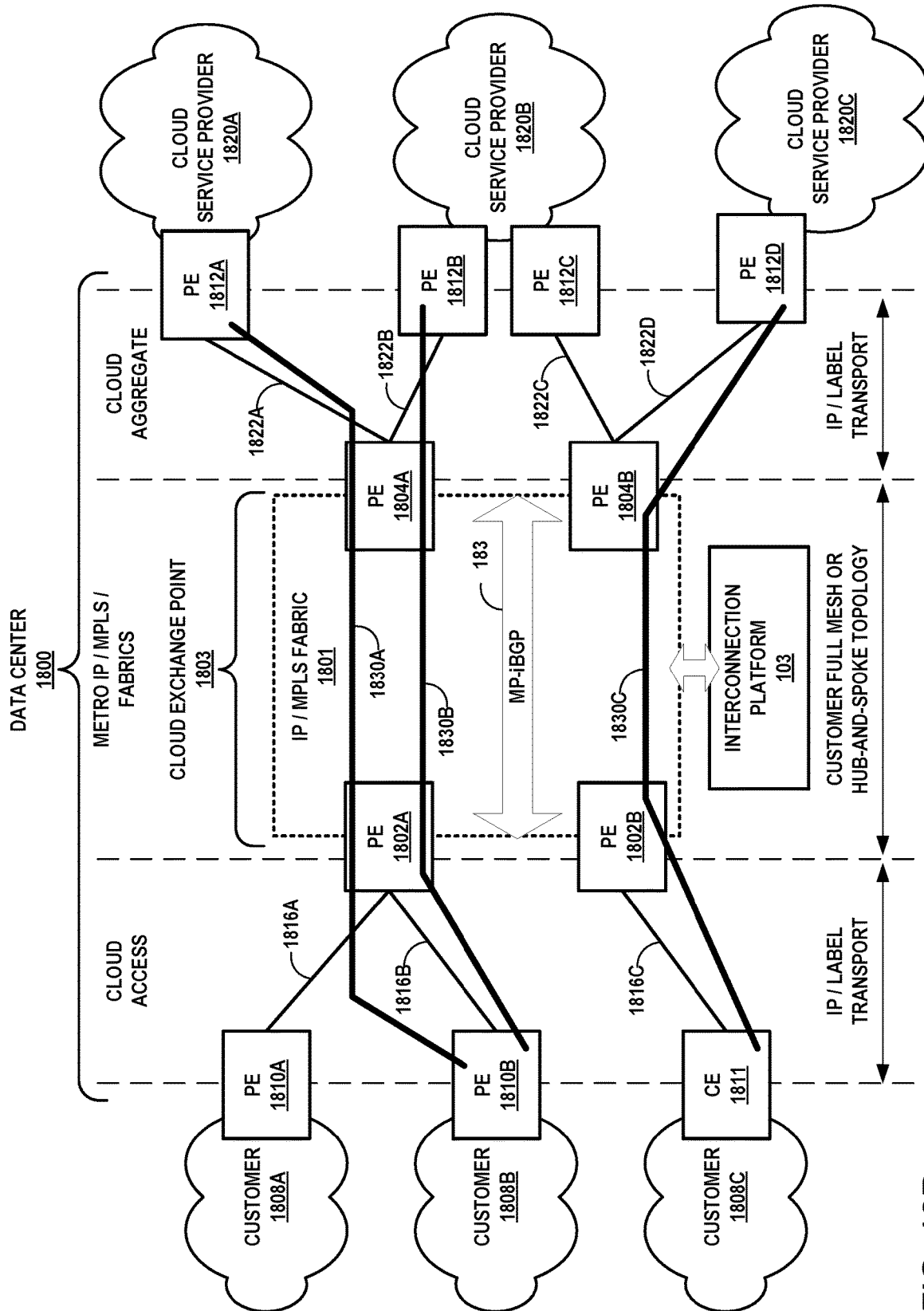

FIG. 18B

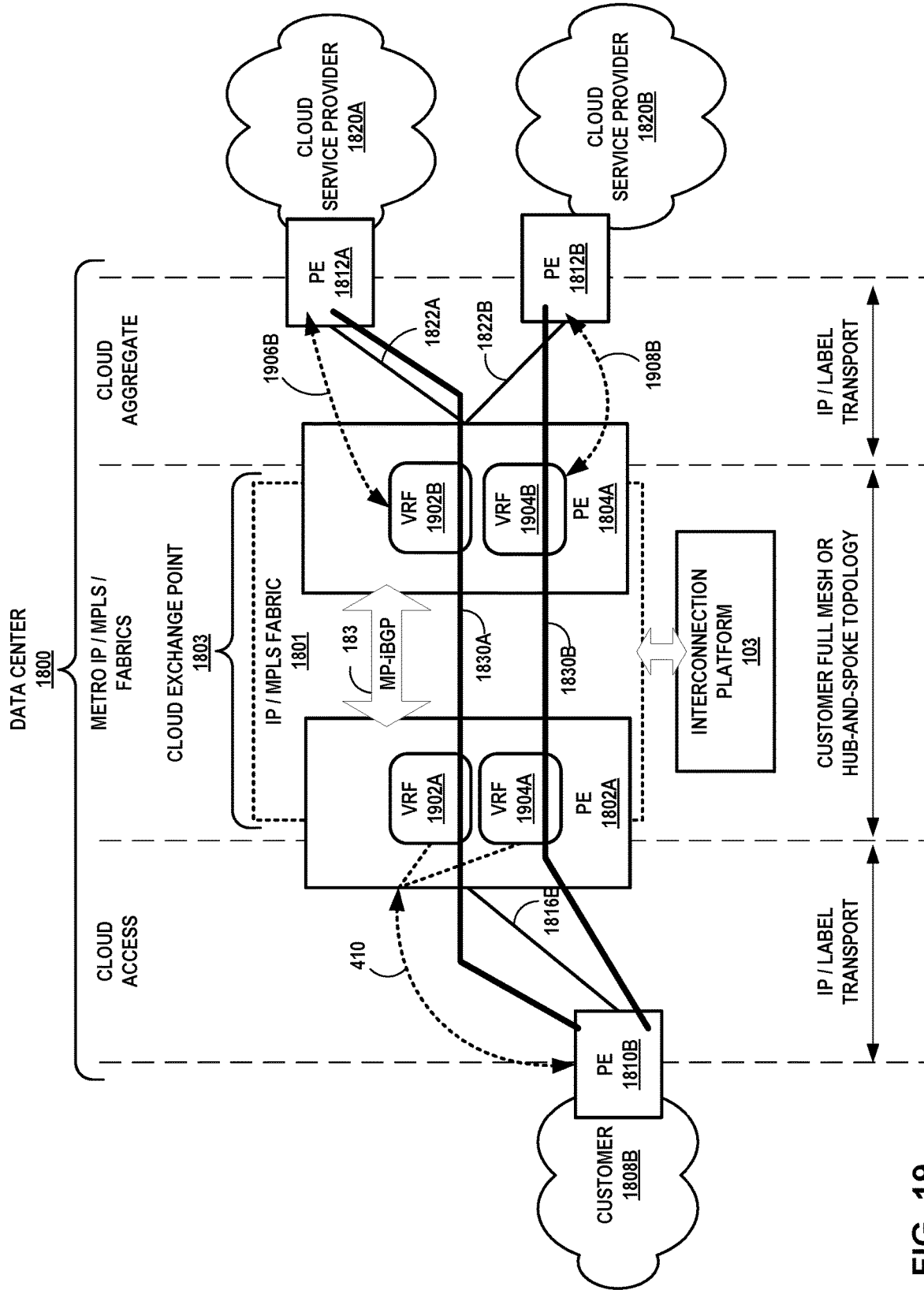

FIG. 19

**INTERCONNECTION PLATFORM FOR
REAL-TIME CONFIGURATION AND
MANAGEMENT OF A CLOUD-BASED
SERVICES EXCHANGE**

This application is a continuation of U.S. application Ser. No. 17/646,375 filed Dec. 29, 2021, which is a continuation of U.S. application Ser. No. 17/007,929 filed Aug. 31, 2020, which is a continuation of U.S. application Ser. No. 16/172,501 filed Oct. 26, 2018, which is a continuation of U.S. application Ser. No. 15/887,165 filed Feb. 2, 2018, which is a continuation of U.S. application Ser. No. 15/395,101 filed Dec. 30, 2016, which is a continuation of U.S. application Ser. No. 14/927,451 filed on Oct. 29, 2015, which claims the benefit of U.S. Provisional Appl. No. 62/072,976, filed Oct. 30, 2014, and of U.S. Provisional Appl. No. 62/233,933, filed Sep. 28, 2015; the entire contents of each of which are incorporated by reference herein.

TECHNICAL FIELD

The invention relates to computer networks and, more specifically, to a platform facilitating interconnectivity among cloud service customers and cloud service providers.

BACKGROUND

Cloud computing refers to the use of dynamically scalable computing resources accessible via a network, such as the Internet. The computing resources, often referred to as a “cloud,” provide one or more services to users. These services may be categorized according to service types, which may include for examples, applications/software, platforms, infrastructure, virtualization, and servers and data storage. The names of service types are often prepended to the phrase “as-a-Service” such that the delivery of applications/software and infrastructure, as examples, may be referred to as Software-as-a-Service (SaaS) and Infrastructure-as-a-Service (IaaS), respectively.

The term “cloud-based services” or, more simply, “cloud services” refers not only to services provided by a cloud, but also to a form of service provisioning in which cloud customers contract with cloud service providers for the online delivery of services provided by the cloud. Cloud service providers manage a public, private, or hybrid cloud to facilitate the online delivery of cloud services to one or more cloud customers.

SUMMARY

In general, this disclosure describes an interconnection platform for dynamically configuring and managing a cloud-based services exchange, or “cloud exchange,” to facilitate virtual connections for cloud services delivery from multiple cloud service providers to one or more cloud customers. The cloud exchange may enable cloud customers to bypass the public Internet to directly connect to cloud services providers so as to improve performance, reduce costs, increase the security and privacy of the connections, and leverage cloud computing for additional applications. In this way, enterprises, network carriers, and SaaS customers, for instance, can integrate cloud services with their internal applications as if such services are part of or otherwise directly coupled to their own data center network.

In some examples, an interconnection platform for a cloud exchange exposes a collection of software interfaces, also referred to herein and described according to applica-

tion programming interfaces (APIs), that allow access to capabilities and assets of the interconnection platform in a programmable fashion. As such, the software interfaces provide an extensible framework that allows software developers associated with customers and partners of the exchange to build software applications that access the interconnection platform that automatically manage interconnection with multiple cloud service providers participating in the interconnection platform. In other words, developers from network services providers, cloud service providers, managed service providers and other enterprises may use the software interfaces exposed by the interconnection platform and defined by the APIs to build custom applications and frameworks for seamless interaction with the interconnection platform to facilitate the delivery of cloud services from cloud service providers to cloud service customers.

These software interfaces defined by the APIs enable machine-to-machine communication for near real-time setup and modifications of interconnections, and may also eliminate or reduce the need for human interaction for the entire interconnection setup and management process. In this way, the software interfaces provide an automated and seamless way to establish, un-install, and manage interconnection with multiple cloud providers participating in an interconnection platform.

In one example, the interconnection platform includes an internal orchestration engine that organizes, directs and integrates underlying software and network sub-systems for managing various aspects of interconnection for the cloud exchange. The orchestration engine may, for example, provide a rule-driven workflow engine that operates between the APIs and the underlying interconnect platform of the exchange. In this way, the orchestration engine can be used by customer-proprietary applications and the APIs for direct participation within the interconnection platform of the cloud exchange.

As described herein, the orchestration engine synthesizes the information and actions to formulate intelligent next steps and responses to dynamic requests made by the customer applications. As such, the orchestration engine abstracts the complexity of the underlying software and network sub-systems of the cloud exchange by providing a uniform, simplified, and secured means to access the interconnection platform.

In some examples, a cloud-based services exchange comprises a network data center that includes respective ports by which a plurality of networks connect to the network data center, each of the networks having a different network address space and associated with a different one of a plurality of customers or cloud service providers; a plurality of interconnection assets within the network data center and configured to connect, through a switching fabric of the network data center, each of the networks associated with the plurality of customers of the cloud-based services exchange to one or more of the networks associated with the cloud service providers, the plurality of interconnection assets including a respective set of one or more virtual circuits for each of the networks associated with the plurality of customers and providing network connectivity within the network data center between the networks associated with the plurality of customers and cloud services executing from within the networks associated with the plurality of cloud service providers; and an interconnection platform executing on one or more management devices within the network data center and presenting a software interface reachable by the networks associated with the plurality of customers and

configured to, in response to receiving a request issued by an application executing within any of the networks associated with the customer, access the plurality of interconnection assets to satisfy the request.

In some examples, cloud-based services exchange comprises a plurality of interconnection assets configured to connect a customer of the cloud-based services exchange to one or more cloud service providers, the plurality of interconnection assets including a virtual circuit by which the customer accesses a cloud service from the one or more cloud service providers; and an orchestration engine configured to modify the plurality of interconnection assets.

In some examples, a method comprises executing, by a cloud-based services exchange on one or more management devices within a network data center, an interconnection platform to present a software interface reachable by networks associated with a plurality of customers; and in response to receiving a request issued by an application executing within any of the networks associated with the customer, access a plurality of interconnection assets of the network data center to satisfy the request, wherein the network data center includes respective ports by which a plurality of networks connect to the network data center, each of the networks having a different network address space and associated with a different one of a plurality of customers or cloud service providers, and wherein a plurality of interconnection assets within the network data center connect, through a switching fabric of the network data center, each of the networks associated with the plurality of customers of the cloud-based services exchange to one or more of the networks associated with the cloud service providers, the plurality of interconnection assets including a respective set of one or more virtual circuits for each of the networks associated with the plurality of customers and providing network connectivity within the network data center between the networks associated with the plurality of customers and cloud services executing from within the networks associated with the plurality of cloud service providers.

The details of one or more examples are set forth in the accompanying drawings and the description below. Other features, objects, and advantages of the techniques will be apparent from the description and drawings, and from the claims.

BRIEF DESCRIPTION OF DRAWINGS

FIG. 1A is a block diagram that illustrates a high-level view of a data center that provides an operating environment for a cloud-based services exchange.

FIG. 1B is a block diagram that illustrates cloud-based services exchange, in accordance with some example implementations described here.

FIG. 1C illustrates another example implementation of a cloud-based services exchange.

FIG. 1D is a block diagram illustrating an example in which a plurality of cloud exchanges points of a cloud exchange managed by an interconnection platform, according to techniques of this disclosure, provide cross-connect availability between geographically distributed carriers.

FIG. 2 is a block diagram that illustrates details of an example architecture for a cloud exchange according to techniques described herein.

FIGS. 3A-3B depict a flow diagram for interconnection software interfaces according to techniques described herein.

FIG. 4 is a block diagram showing an alternative representation of an interconnection platform 103 for a cloud exchange according to techniques described in this disclosure.

FIGS. 5-11 are flow diagrams each illustrating a call flow and operations performed by example components of an interconnection platform for a cloud exchange, as described in this disclosure.

FIG. 12 is a block diagram illustrating further details of one example of a computing device that operates in accordance with one or more techniques of the present disclosure.

FIG. 13 is a block diagram illustrating an example system showing a logical architecture of an orchestration engine, in further detail, according to techniques described herein.

FIG. 14 is a block diagram illustrating an example system showing reference architecture of an orchestration engine, in further detail, according to techniques described herein.

FIG. 15 is a flowchart illustrating an example workflow performed by an orchestration engine in accordance with example aspects of this disclosure.

FIG. 16 is an example logical diagram illustrating an example orchestration engine workflow relating to creating a virtual circuit in accordance with example aspects of this disclosure.

FIG. 17 is an example logical diagram illustrating an example orchestration engine workflow relating to obtaining employee payroll information in accordance with example aspects of this disclosure.

FIGS. 18A-18B are block diagrams illustrating example network infrastructure and service provisioning by a programmable network platform for a cloud exchange that aggregates the cloud services of multiple cloud service providers for provisioning to customers of the cloud exchange provider and aggregates access for multiple customers to one or more cloud service providers, in accordance with techniques described in this disclosure.

FIG. 19 is a block diagram illustrating an example of a data center-based cloud exchange point in which routers of the cloud exchange point are configured by an interconnection platform with virtual private network routing and forwarding instances for routing and forwarding aggregated service traffic from multiple cloud service provider networks to a customer network, according to techniques described herein.

Like reference characters denote like elements throughout the figures and text.

DETAILED DESCRIPTION

In general, this disclosure describes an interconnection platform for real-time configuration and management of a cloud-based services exchange (“cloud exchange”). As described herein, the interconnection platform provides customers of the exchange, e.g., enterprises, network carriers, and SaaS customers, with secure, private, virtual connections to multiple cloud service providers (CSPs) globally. The multiple CSPs participate in the cloud exchange by virtue of their having at least one accessible port in the cloud exchange by which a customer can connect to the one or more cloud services offered by the CSPs, respectively.

According to various examples described herein, a cloud exchange is described that allows private networks of any customer to be directly cross-connected to any other customer at a common point, thereby allowing direct exchange of network traffic between the networks of the customers. Customers may include network carriers (or network service

providers), enterprises, and other users of cloud services offered by one or more cloud service providers.

FIG. 1A is a block diagram that illustrates a high-level view of a data center **101** that provides an operating environment for a cloud-based services exchange **100**. Cloud-based services exchange **100** (“cloud exchange **100**”) allows a corresponding one of customer networks **104D**, **104E** and carrier networks **104A-104C** (collectively, “private networks **104**”) of any carriers **106A-106C** (collectively, “carriers **106**”) or other cloud customers including customers **107A**, **107B** to be directly cross-connected, via a virtual layer 2 (L2) or layer 3 (L3) connection to any other customer network and/or to any of cloud service providers **110A-110N** (collectively, “CSPs **110**”), thereby allowing direct exchange of network traffic among the customer networks and CSPs **110**.

Carriers **106** may each represent a network service provider that is associated with a transit network by which network subscribers of the carrier **106** may access cloud services offered by CSPs **110** via the cloud exchange **100**. In general, customers of CSPs **110** may include network carriers, large enterprises, managed service providers (MSPs), as well as Software-as-a-Service (SaaS), Platform-as-a-Service (PaaS), Infrastructure-as-a-Service (IaaS), Virtualization-as-a-Service (VaaS), and data Storage-as-a-Service (dSaaS) customers for such cloud-based services as are offered by the CSPs **110** via the cloud exchange **100**.

In this way, cloud exchange **100** streamlines and simplifies the process of partnering CSPs **110** and customers (via carriers **106** or directly) in a transparent and neutral manner. One example application of cloud exchange **100** is a colocation and interconnecting data center in which CSPs **110** and carriers **106** and/or customers **107** may already have network presence, such as by having one or more accessible ports available for interconnection within the data center. This allows the participating carriers, customers, and CSPs to have a wide range of interconnectivity options in the same facility. Cloud exchange **100** of data center **101** includes network infrastructure **122** that provides a L2/L3 switching fabric by which CSPs **110** and customers/carriers interconnect. This enables a carrier/customer to have options to create many-to-many interconnections with only a one-time hook up to the switch fabric and underlying interconnection platform **103** of cloud exchange **100**. In other words, instead of having to establish separate connections across transit networks to access different cloud service providers or different cloud services of one or more cloud service providers, cloud exchange **100** allows customers to interconnect to multiple CSPs and cloud services using network infrastructure **122** within data center **101**.

By being connected to and utilizing cloud exchange **100**, customers can purchase services and reach out to many end users in many different geographical areas without incurring the same expenses typically associated with installing and maintaining multiple virtual connections with multiple CSPs **110**. By connecting to cloud exchange **100**, a carrier **106** may be able to generate additional revenue by offering to sell its network services to the other carriers.

In some example implementations described herein, cloud exchange **100** includes an interconnection platform **103** that exposes a collection of software interfaces, also referred to herein as application programming interfaces (APIs) **114** in that the APIs **114** define the methods, fields, and/or other software primitives by which applications may invoke the interconnection platform **103**. The software interfaces allow carriers **106** and customers **107** programmable access to capabilities and assets of the cloud exchange **100**.

On the buyer side, the software interfaces presented by the underlying interconnect platform provide an extensible framework that allows software developers associated with the customers of cloud exchange **100** to create software applications that allow and leverage access to the interconnect platform by which the applications may request that the cloud exchange establish connectivity to cloud services offered by any of the CSPs **110**. For example, these buyer-side software interfaces (or “buyer APIs” of APIs **114**) may allow customer applications for NSPs and enterprise customers, e.g., to obtain authorization to access the cloud exchange, obtain information regarding available cloud services, obtain active ports and metro area details for the customer, create virtual circuits of varying bandwidth to access cloud services (including dynamic selection of bandwidth based on a purchased cloud service to create on-demand and need based virtual circuits to cloud service providers), delete virtual circuits, obtain active virtual circuit information, obtain details surrounding CSPs partnered with the cloud exchange provider, obtain customized analytics data, and validate partner access to interconnection assets.

On the provider (seller) side, the software interfaces may allow software developers associated with cloud providers to manage their cloud services and to enable customers to connect to their cloud services. For example, these seller-side software interfaces (or “seller APIs” of APIs **114**) may allow cloud provider applications to obtain authorization to access the cloud exchange, obtain information regarding available cloud services, obtain active ports and metro area details for the provider, obtain active port details in a given data center for the provider, approve or reject virtual circuits of varying bandwidth to access cloud services created by customers, obtain virtual circuits pending addition and confirm addition of virtual circuits, obtain virtual circuits pending deletion and confirm deletion of virtual circuits, obtain customized analytics data, and validate partner access to interconnection assets.

As further described herein, the APIs **114** facilitate machine-to-machine communication to enable dynamic provisioning of virtual circuits in the cloud exchange for interconnecting customer and provider networks. In this way, the interconnection platform **103** enables the automation of aspects of cloud services provisioning. For example, the software interfaces may provide an automated and seamless way for customers to establish, de-install and manage interconnection with multiple, different cloud providers participating in the cloud exchange.

In some examples, cloud exchange **100** includes an API gateway **112** having one or more processors that executes one or more applications that expose software interfaces defined according to APIs **114**. The applications may invoke services that correspond to endpoints of the APIs **114**, and the services may themselves invoke the cloud exchange platform service of orchestration engine **118**. API gateway **112** may execute on a management device such as one or virtual machines and/or real servers of data center **101**. Although shown as a single element in FIG. 1A, API gateway **112** may comprise a cluster of one or more physical and/or virtual computing machines executing on one or more physical processors.

In some examples, cloud exchange includes an orchestration engine **118** that organizes, directs and integrates underlying software sub-systems **120** for managing various aspects of interconnection within the network infrastructure **122** as well as cloud services management. The orchestration engine **118** may, for example, provide a rule-driven workflow engine that operates between the APIs **114** and the

underlying interconnect platform of cloud exchange **100** that includes sub-systems **120** and network infrastructure **122**. In this way, the orchestration engine **118** can be used by customer-proprietary applications and the APIs **114** for direct participation with the interconnection platform **103** of the cloud exchange **100**. In other words, the orchestration engine **118** offers a “cloud exchange platform service” having various application engines or workflows to handle the API gateway **112** service requests.

Sub-systems **120** and orchestration engine **118** may each be centralized or distributed applications and may execute on a management device such as one or virtual machines and/or real servers of data center **101**.

Network infrastructure **122** represents the cloud exchange switching fabric and includes multiple ports that may be dynamically interconnected with virtual circuits using by invoking APIs **114** according to techniques described herein. Each of the ports is associated with one of carriers **106**, customers **107**, and CSPs **110**. A virtual circuit may refer to, e.g., an Ethernet connection such as a Layer 2 VPN or virtual private LAN (e.g., E-LINE, E-LAN, E-TREE, or E-Access), an Internet exchange-based interconnection in which respective routers of interconnected customers directly peer and exchange layer 3 routes for service traffic exchanged via the exchange **100**, and a cloud exchange in which customer routers peer with exchange **100** (or “provider”) routers rather than directly with other customers. Example details of a cloud exchange are provided below with respect to FIGS. **18A**, **18B**, and **19**.

For interconnections at layer-3 or above, customers **107** and carriers **106** may receive services directly via a layer 3 peering and physical connection to exchange **100** or indirectly via one of carriers **106**. Carriers **106** provide “transit” by maintaining a physical presence within one or more of exchanges and aggregating layer 3 access from one or customers **107**. Carriers **106** may peer, at layer 3, directly with one or more exchanges and in so doing offer indirect layer 3 connectivity and peering to one or more customers **107** by which customers **107** may obtain services from the exchange **100**.

FIG. **1B** is a block diagram that illustrates cloud-based services exchange **100**, in accordance with some example implementations described here. In this example architecture, cloud exchange **100** includes multiple cloud exchange points **128A-128C** (also described as “cloud exchange points”) and collectively referred to as “cloud exchange points **128**”), which may represent geographically distributed data centers within a metropolitan area and in which cloud exchange **100** may directly or indirectly (via NSPs **106**) interconnect cloud services providers **110** with cloud customers **108** accessing cloud services.

Applications **130** developed and deployed by CSPs **110**, NSPs **106**, and customers **108** invoke APIs **114** of interconnection platform **103** to, for example, automatically control provisioning and manage aspects of cloud exchange **100** for aspects of interconnection with one or more cloud providers/customers, including: (1) provisioning of interconnects, (2) identification and authorization of carriers, (3) management and fulfillment of orders, (4) delivery of network services, (5) managing inventory and capacity, (6) managing and reporting/alerting incidents, and (7) content management.

In this example, APIs **114** includes endpoints **116A-116K** (collectively, “endpoints **116**”) that each represents a resource exposed by interconnection platform **103**. Examples of endpoints are described below in further detail with respect to FIG. **3A**. Applications **130** may interact with API gateway **112** according to client/server model. Appli-

cations **130** may send a request directed to any of endpoints **116** of APIs **114**. API gateway **112**, in response to requests, invokes the cloud exchange platform service of orchestration engine **118**, which may orchestrate a workflow of service tasks for the underlying sub-systems **120** to satisfy the request. In response to the request, e.g., upon completion of the workflow, API gateway **112** may send a response to the requesting application **130** from the endpoint **116** invoked.

In some examples, APIs **114** may conform to a Representational State Transfer model, i.e., be a RESTful interface, with endpoints **116** representing different methods of the RESTful interface. Applications **130** may invoke any of endpoints **116** using a communication protocol for transferring application data (e.g. HTTP) that specifies the method, a resource Uniform Resource Identifier (URI), and optionally parameters for the method. API gateway **112** translates the resource URI and the optional parameters to cloud exchange platform-related constructs and invokes the cloud exchange platform of orchestration engine **118** according to one of a create, read, update, and delete (CRUD) or confirmation action corresponding to the endpoint **116** specified by the application data. In HTTP parlance, the create action corresponds to the POST method, read to the GET method, and confirmation to the PATCH method, for example.

Sub-systems **120** may apply the service tasks orchestrated by orchestration engine **118**, which may include modifying any of cloud exchange points **128** to perform the on-demand setup of virtual circuits between CSPs **110** and customers **108**, for example, or otherwise manage cloud exchange points **128** interconnection assets such as ports, metros, data centers, virtual circuits and virtual circuit bandwidth, profiles, and configuration.

Cloud exchange **100** of FIG. **1B** illustrates a metro-based cloud exchange that provides multiple cloud exchange points according to techniques described herein. Each of cloud-based services exchange points **128A-128C** of cloud-based services exchange **100** may represent a different data center geographically located within the same metropolitan area (“metro-based,” e.g., in New York City, New York; Silicon Valley, California; Seattle-Tacoma, Washington; Minneapolis-St. Paul, Minnesota; London, UK; etc.) to provide resilient and independent cloud-based services exchange by which cloud-based services customers (“cloud customers”) and cloud-based service providers (“cloud providers”) connect to receive and provide, respectively, cloud services. In various examples, cloud exchange **100** may include more or fewer cloud exchange points **128**. In some instances, a cloud exchange **100** includes just one cloud exchange point **128**. As used herein, reference to a “cloud exchange” or “cloud-based services exchange” may refer to a cloud exchange point. A cloud exchange provider may deploy instances of cloud exchanges **100** in multiple different metropolitan areas, each instance of cloud exchange **100** having one or more cloud exchange points **128**.

Each of cloud exchange points **128** includes network infrastructure and an operating environment by which cloud customers **108A-108D** (collectively, “cloud customers **108**”) receive cloud services from multiple cloud service providers **110A-110N** (collectively, “cloud service providers **110**”). Cloud customers **108** may receive cloud services directly via a layer 3 peering and physical connection to one of cloud exchange points **128** or indirectly via one of network service providers **106A-106B** (collectively, “NSPs **106**,” or alternatively, “carriers **106**”). NSPs **106** provide “cloud transit” by maintaining a physical presence within one or more of cloud exchange points **128** and aggregating

layer 3 access from one or customers **108**. NSPs **106** may peer, at layer 3, directly with one or more cloud exchange points **128** and in so doing offer indirect layer 3 connectivity and peering to one or more customers **108** by which customers **108** may obtain cloud services from the cloud exchange **100**. Each of cloud exchange points **128**, in the example of FIG. 1B, may be assigned a different autonomous system number (ASN). For example, cloud exchange point **128A** may be assigned ASN **1**, cloud exchange point **128B** may be assigned ASN **2**, and so forth. Each cloud exchange point **128** is thus a next hop in a path vector routing protocol (e.g., BGP) path from cloud service providers **110** to customers **108**. As a result, each cloud exchange point **128** may, despite not being a transit network having one or more wide area network links and concomitant Internet access and transit policies, peer with multiple different autonomous systems via external BGP (eBGP) or other exterior gateway routing protocol in order to exchange, aggregate, and route service traffic from one or more cloud service providers **110** to customers. In other words, cloud exchange points **128** may internalize the eBGP peering relationships that cloud service providers **110** and customers **108** would maintain on a pair-wise basis. Instead, a customer **108** may configure a single eBGP peering relationship with a cloud exchange point **128** and receive, via the cloud exchange, multiple cloud services from one or more cloud service providers **110**. While described herein primarily with respect to eBGP or other layer 3 routing protocol peering between cloud exchange points and customer, NSP, or cloud service provider networks, the cloud exchange points may learn routes from these networks in other way, such as by static configuration, or via Routing Information Protocol (RIP), Open Shortest Path First (OSPF), Intermediate System-to-Intermediate System (IS-IS), or other route distribution protocol.

As examples of the above, customer **108D** is illustrated as having contracted with a cloud exchange provider for cloud exchange **100** to directly access layer 3 cloud services via cloud exchange points **128C**, **128D**. In this way, customer **108D** receives redundant layer 3 connectivity to cloud service provider **110A**, for instance. Customer **108C**, in contrast, is illustrated as having contracted with the cloud exchange provider for cloud exchange **100** to directly access layer 3 cloud services via cloud exchange point **128C** and also to have contracted with NSP **106B** to access layer 3 cloud services via a transit network of the NSP **106B**. Customer **108B** is illustrated as having contracted with multiple NSPs **106A**, **106B** to have redundant cloud access to cloud exchange points **128A**, **128B** via respective transit networks of the NSPs **106A**, **106B**. The contracts described above are instantiated in network infrastructure of the cloud exchange points **128** by L3 peering configurations within switching devices of NSPs **106** and cloud exchange points **128** and L3 connections, e.g., layer 3 virtual circuits, established within cloud exchange points **128** to interconnect cloud service provider **110** networks to NSPs **106** networks and customer **108** networks, all having at least one port offering connectivity within one or more of the cloud exchange points **128**.

For layer 3 cloud services, a virtual circuit may represent a layer 3 path through an IP/MPLS fabric of one or more of cloud exchange points **128**, between an attachment circuit connecting a customer network to the cloud exchange point and an attachment circuit connecting a cloud service provider network to the cloud exchange point. Each virtual circuit may include at least one tunnel (e.g., an LSP and/or

Generic Route Encapsulation (GRE) tunnel) having endpoints at the provider edge/autonomous system boundary of the cloud exchange point.

Cloud exchange points **128** may be configured to implement multiple layer 3 virtual circuits to interconnect customer/NSP networks and cloud service provider networks with end-to-end IP paths. Each of cloud service providers and customers/NSPs may be an endpoint for multiple virtual circuits, with multiple virtual circuits traversing one or more cloud exchange points **128** to connect the endpoints. An example implementation of a cloud exchange point is described in further detail below with respect to FIGS. **18A-18B** and **19**.

FIG. 1C illustrates another example implementation of a cloud-based services exchange. In this example, cloud exchange **100** provides high-speed attachment circuits **208**, **213**, **218** and **223** and routing and switching infrastructure for provisioning direct, virtual circuits **150**, **155**, **160**, **165**, **170**, collectively referred to as an interconnect-platform, for cross-connecting carrier networks **205**, **210**, **215** and **220** over External Network-to-Network Interface (E-NNIs) **206**, **211**, **216**, and **221**.

As shown in the example of FIG. 1B, cloud exchange **100** exposes a collection of software interfaces **114**, also referred to herein as application programming interfaces (APIs), that allow customer systems **196** programmatic access to capabilities and assets of the interconnection platform **103** of cloud exchange **100**. That is, software interfaces **114** provide an extensible framework that allows software developers associated with the customers of cloud exchange **100** to create software applications executable on customer systems **196** that allow and leverage access subsystems **120** of exchange **100**. Underlying subsystems **120** of exchange **100** may, for example, control provisioning and managing of all aspects of exchange **100**, including: (1) provisioning interconnects between customer system **196**, (2) identification and authorization of carriers, (3) management and fulfillment of orders, (4) delivery of network services, (5) managing inventory and capacity, (6) managing and reporting/alerting incidence and (7) content management.

As such, carriers **106** and other customers of cloud exchange **100**, such as network services providers, cloud services providers, managed service providers and other enterprises may make use the software interfaces exposed by the interconnect platform to manage their direct cross-connects with other carriers. That is, software interfaces **114** enable machine-to-machine communication, shown as dotted arrows in FIG. 1C, between network infrastructure and provisioning/billing/accounting/AAA systems positioned within different carrier networks **205**, **210**, **215** and **220** for carriers **106** establishing and managing direct cross-connects. As such, software interfaces **114** enable near real-time setup and modifications of interconnections, e.g., virtual circuits of FIG. 1C, and may also eliminate or reduce the need for human interaction for the entire interconnection set-up and management process. In this way, the software interfaces provide an automated and seamless way for carriers **106** to establish, de-install and manage interconnection with multiple, different customers participating in an interconnection platform **103**.

Moreover, as further shown in the example of FIG. 1B, cloud exchange **100** includes an internal orchestration engine **118** that organizes, directs and integrates underlying software and network sub-systems **120** for managing various aspects of the interconnection services provided by cloud exchange **100**. Orchestration engine **118** may, for example, provide a rule-driven workflow engine that operates between

APIs 114 and the underlying interconnect platform provided by subsystems 120 of cloud exchange 100. In this way, orchestration engine 118 can be invoked by customer-proprietary applications executing on customer systems 196 by way of APIs 190 for direct participation within the interconnection platform of the cloud exchange.

As described herein, orchestration engine 118 synthesizes the information and actions from underlying sub-systems 120 of the interconnect platform to formulate intelligent next steps and responses to the customer applications. As such, orchestration engine 118 abstracts the complexity of the underlying software and network sub-systems 120 of the cloud exchange 100 by providing a uniform, simplified and secured means to access the interconnection platform.

FIG. 1D is a block diagram illustrating an example in which a plurality of cloud exchanges points of a cloud exchange 100 managed by an interconnection platform, accordingly to techniques of this disclosure, provide cross-connect availability between geographically distributed carriers. Although not shown, each of cloud exchange points may implement the example techniques described with respect to the cloud exchanges 100 of FIGS. 1A-1C including cloud exchange points 128 of FIG. 1B.

FIG. 2 is a block diagram that illustrates details of an example architecture for a cloud exchange according to techniques described herein. As shown in this example, example cloud exchange 100 illustrates APIs 114, internal orchestration engine 118, and sub-systems 120 in further detail.

Developer community 300 illustrates entities that may develop applications that use APIs 114 to access the interconnection platform of the cloud exchange 100. These entities include network service providers 300A, managed service providers 300B, enterprises 300C, cloud service providers 300D, third-party developers 300E, and others 300F. Applications developed by these entities utilize cloud exchange 100 as an interconnection platform for interconnecting customers to cloud services offered by cloud services providers according to the policies and profiles of the various entities.

In this example, APIs 114 includes bundles of the various API methods or endpoints according to function. Discovery APIs 304A may be usable to perform availability of location discovery, asset discovery, and cloud service discovery. Discoverable information may include available metropolitan areas, data centers, ports, services, virtual circuits, and other interconnection assets by which a customer may obtain or manage cloud services. Transact APIs 304B may be usable to dynamically provision end-to-end virtual circuits of varying bandwidths through machine-to-machine interaction, validate virtual circuits requested by a customer, and confirm deletion of virtual circuits, for example. Use APIs 304C may be usable to allow providers and customers to dynamically obtain recommendation information as performed by a recommendation engine of cloud exchange 100, obtain customized analytics regarding competitor presence, cloud service presence/availability, and customer presence/availability, obtain usage statistics, and to manage content, for example. Support APIs 304D may be usable by customers or providers to manage accounts, perform automated billing/invoicing, validate credit, and configure profile and configuration information for the entity, for example.

In this example, orchestration engine 118 (illustrated as “interconnection orchestration engine 118”) organizes, directs, and integrates underlying software and network sub-systems 120 for managing various aspects of interconnection. For example, orchestration engine 118 may handle

the entire quote-to-cash cycle for provisioning of interconnection assets by communicating with myriad interconnection enablement sub-systems 120, such as Customer Account and Profile Management Systems, Customer Asset Management Systems, Inventory Management Systems, Capacity Management Systems, Network Systems, Credit Management Systems, Content Management Systems, and Trouble Ticket Management System (not all shown in FIG. 2). To that end, orchestration engine 118 includes a workflow and rules engine 306 that responsively operates according to configured exchange policies 308A, profiles 308B, and configurations 308C to synthesize information and actions from sub-systems 120 to formulate intelligent next steps and responses to requests received via APIs 114. Microservices component 308D componentizes many, and in some cases all, of the interconnection services to improve horizontal scalability, performance efficiency, and low-to-zero down-time feature upgrades and enhancements. In this way, orchestration engine 118 may abstract the complexity of underlying software and sub-systems 120 by providing a uniform, simplified and secured means to access the interconnection platform for accessing and managing interconnection assets.

Sub-systems 120 orchestrated by orchestration engine 118 in the example of FIG. 2 include identification (ID) and access management system 310A. In some examples, ID and access management system 310A includes a Permission Data Store (PDS) to house the customer, asset and permission hierarchy. ID and access management system 310A may accomplish federation using a third party system which generates Security Assertion Markup Language (SAML) assertions and is also capable of providing Single Sign-On (SSO) capability.

Orchestration engine 118 may orchestrate multiple order management systems 310B (e.g., for different regions such as Asia Pacific, Europe, Middle East and Africa and North America). Orchestration engine 118 passes relevant virtual circuit order creation information to these order management systems 310B so that the partners can be billed. Orchestration engine 118 may abstract the complexity of the underlying network systems by seamlessly integrating with the network services system 310C to interact with the underlying network systems. Orchestration engine 118 may leverage an asset inventory and capacity management system 310D in conjunction with the Permission Data Store to obtain information about customer ports inventory. Orchestration engine 118 may leverage this information to place virtual circuit requests against the appropriate ports. Asset inventory and capacity management system 310D may be used to evaluate the available bandwidth on each port before provisioning of the virtual circuits.

Orchestration engine 118 accepts incident requests from partners and customers and communicates with the underlying incident management system 310E to raise service tickets. Orchestration engine 118 communicates with the content management system 310F to, e.g., render internationalized and localized content for a customer based on the language preference of the customer. Content management system 310F aids in transparent translation of all labels, error messages, success messages and responses displayed on the web portal, mobile devices or in machine-to-machine communication via APIs 114.

FIGS. 3A-3B depict a flow diagram for interconnection software interfaces according to techniques described herein. In this example, API gateway 403 exposes an API 114 having multiple endpoints 406A-406L (collectively, “endpoints 406”) by which API consumers 402 may manage

13

cloud exchange interconnections. API gateway 403, in turn, invokes the cloud service platform of orchestration engine 407, which orchestrates a workflow of service tasks represented in FIGS. 3A-3B by cloud exchange API services 409. API gateway 403 may represent an example instance of API gateway 112 of FIGS. 1A-1D, orchestration engine 407 may represent an example instance of orchestration gateway 118 of FIGS. 1A-1D, and sub-systems 120 of FIGS. 1-2 may offer cloud exchange API services 409.

API consumers 402 may include buyer applications 402A and seller applications 402B, as well as API developers 402C that may develop such applications. API gateway 403 includes a number of customer adaptors 404 that facilitate the operations of API gateway 403. Custom adaptors 404 include security 404A, API key verification 404B, transformation 404C, caching 404D, threat protection 404E, spike arrest 404F, custom analytics 404G, and HTTP callouts 404H.

Endpoints 406 represent available logical and/or physical resources accessible to API consumers 402. That is, API consumers 406 may access endpoints 406 to access the interconnection platform of a cloud exchange to get information regarding, create, modify, delete, and/or confirm requests for corresponding resources of the cloud exchange. Endpoints 406 may represent example instances of endpoints 116 of FIGS. 1B-1C.

In this example, endpoints 406 include login 406A, ports 406B, metros 406C, assets 406D, virtual circuits 406E, cloud services 406F, service profiles 406G, analytics 406H, traffic statistics 406I, bandwidths 406J, service tickets 406K, and recommendations 406L. In general, API consumers 406 may invoke any of endpoints 406 using a corresponding method and, in some cases, parameters that determine how the interconnection platform executes the method.

Endpoints 406 may represent different methods of a RESTful interface. API consumers 402 may invoke any of endpoints 406 using a communication protocol for transferring application data (e.g. HTTP) that specifies the method, a resource URI, and optionally parameters for the method. API gateway 403 translates the resource URI and the optional parameters for the endpoint 406 to cloud exchange platform-related constructs and invokes the cloud exchange

14

platform of orchestration engine 407 according to one of a create, read, update, delete, or confirmation action corresponding to the endpoint 406 specified by the application data.

APIS—EXAMPLES

The following sections contain example details for selected endpoints 406 of APIs 114 for a cloud exchange 100. The API 114 provides functionality for allowing developers to access the interconnect platform for ordering and viewing virtual circuits. This API functionality includes getting information about and performing operations on Login 406A, Ports 406B, Virtual Circuits 406E, Metros 406C, and Cloud Services 406F.

In one example, endpoints 406 of APIs 114 may be categorized into three major categories:

Foundational APIs—these APIs are common to both the buyer and the seller.

Buyer APIs—These are the APIs that are used by the Enterprises, Network Service

Providers (NSP) and Managed Service Providers (MSP) to establish connectivity to cloud services offered by the different Cloud Service Providers (CSPs).

Seller APIs—These APIs are used by the CSPs to manage their cloud services at cloud exchange 100 and to enable buyers to connect to their services.

The APIs are broadly categorized into operations that can be performed on different resources. This section also details the common request headers that are required to be included as part of every request and also the response headers that are returned back with each API response. In addition, this section describes the HTTP status and custom error codes used as part of the API response in the event of any error condition.

The tables below show an overview of the API resources, their respective URIs, and supported operations on each resource. The APIs are divided in three major sections: Buyer, Seller, and Foundational APIs. Reference herein to XML refers to eXtensible Markup Language, while JSON refers to JavaScript Object Notation.

Foundational API Overview

Resource	HTTP Operations	URI
Access Token	POST	POST /oauth2/v1/token
Metros Cloud Services	GET	GET /ecx/v1/metros GET /ecx/v1/cloudservices GET /ecx/v1/cloudservices/{cloud_service_name}
Refresh token	POST	POST /oauth2/v1/refreshaccesstoken

Buyer API Overview

Resource	HTTP Operations	URI
Ports	GET	GET /ecx/v1/ports GET /ecx/v1/ports/{port_name}
Virtual Circuits	GET, POST, DELETE, PATCH	GET /ecx/v1/virtualcircuits POST /ecx/v1/virtualcircuits GET /ecx/v1/virtualcircuits/{ virtual_circuit_id } DELETE /ecx/v1/virtualcircuits/{ virtual_circuit_id } PATCH /ecx/v1/virtualcircuits/{ virtual_circuit_id }
User Assets	GET	GET /ecx/v1/assets

-continued

Resource	HTTP Operations	URI
Seller Services	GET	GET /ecx/v1/sellerservices,
Seller Service Profiles	GET	GET /ecx/v1/sellerservices/{seller_service_name}
		GET /ecx/v1/sellerserviceprofiles/{profile_name}/metadata

10

Seller API Overview

Resource	HTTP Operations	URI
Ports	GET	GET /ecx/v1/ports GET /ecx/v1/ports/{port_name}
Virtual Circuits	GET, PATCH	GET /ecx/v1/virtualcircuits PATCH /ecx/v1/virtualcircuits/{ virtual_circuit_id }
User Assets	GET	GET /ecx/v1/virtualcircuits/{ virtual_circuit_id }
Seller Service Profile	POST, PUT, DELETE	POST /ecx/v1/sellerserviceprofiles PUT /ecx/v1/sellerserviceprofiles/{profile_name}/ports DELETE /ecx/v1/sellerserviceprofiles/{profile_name}

HTTP Status Codes

The table below lists example HTTP status codes that can be utilized by APIs 114. There are specific error codes and messages which are returned back in error scenarios which are defined along with the appropriate API specification.

HTTP Code	Description
200	OK
201	Created
204	No Content
400	Bad Request
403	Forbidden
401	Unauthorized
404	Not Found
405	Method not Allowed
406	Not Acceptable
409	Conflict
415	Unsupported Media Type
500	Internal Server Error
503	Service Unavailable
504	Gateway Timeout

Common Request Headers

The following headers are required in requests to all APIs.

Header Attribute	Allowed Values	Required	Description
Content-Type	application/json application/xml	Yes	The media type of the request body

-continued

Header Attribute	Allowed Values	Required	Description
Accept	application/json application/xml	Yes	The media types acceptable for the response

Common Response Headers

The following header is included as part of all API responses

Header Attribute	Allowed Values	Required	Description
Content-Type	application/json application/xml	Yes	The content type passed in the response body

Error Response Syntax

The error responses from all APIs follow the common syntax shown below.

```

{
  "errors": [
    {
      "status": "string",
      "code": "string",
      "property": "string",
      "message": "string",
      "more_info": "string"
    }
  ]
}
    
```

Error Response Message Fields

errors	
Description	A list of errors
Type	List
Required	Yes
Default	None
Example	None

-continued

status	
Description	HTTP Status Code
Type	String
Required	Yes
Default	None
Example	409
code	
Description	Internal ECX Error Code
Type	string
Required	Yes
Default	None
Example	40902
property	
Description	Attribute Name that has errors
Type	string
Required	No
Default	None
Example	vlan_id
message	
Description	Description of the error
Type	string
Default	None
Example	Duplicate VLAN id: A VLAN with the same value already exists for this port
Required	No
more_info	
Description	More information about the error on the developer portal.
Type	string
Default	None
Example	https://api.developer.cloudexchange.com/docs/api/errors/40902
Required	No

Sample Error Response:

```
Content-Type: application/json
{
  "errors": [
    {
      "code": 40007,
      "message": "Invalid Field Value",
      "more_info": "The field value port_name already exists for the
specified profile name",
      "property": "port_name",
      "status": 400
    }
  ]
}
```

In some examples, developers may be expected to generate API consumer Key and Consumer Secret using a developer platform before invoking the APIs.

Authentication

Developer acquires an access token through a valid login before invoking any APIs **114**. Refer to the section describing login **406A** for details.

Foundational APIs

Resource: Access Token or Login **406A**.

Description: OAuth2.0 token for accessing APIs **114**.

HTTP Method	Request URI
POST	/oauth2/v1/token

POST Access Token
Description: This API handles authentication and authorization of the API developer. Upon successful authentication

35 tion an access_token is returned as part of the response. An error message is returned on unsuccessful attempts.

Request

Request URI: POST http://<HostName>/ecx/v1/oauth/token

40 Filter Parameters:

None

Request Headers:

None

Request Fields:

45

grant_type	
Description	OAuth grant operation. Acceptable value: password
Type	String
Required	Yes
Default	None
Example	client_credentials
user_name	
Description	User name for login
Type	string
Required	Yes
Default	None
Example	tempuser1
user_password	
Description	Password for login
Type	string
Required	Yes
Default	None
Example	xxxxxxx
client_id	

60

65

Description	API Consumer Key
Type	string

19

-continued

Required	Yes
Default	None
Example	QWERTY1234567afgaaa password_encoding
Description	<p>Password encoding used.</p> <p>If this field is not present the password is considered to be in plain text format.</p> <p>Password Encryption: Following encryption modes are supported:</p> <p>None</p> <p>Password sent as plaintext.</p> <p>md5-b64</p> <p>The password is encoded using MD5/Base64 encoding. MD5 digest has to be generated in byte format (not MD5 hex digest) and then encoded into base64 (Recommended)</p> <p>b64</p> <p>The password is encoded using Base64</p>
Type	string
Default	None
Required	No
Example	md5-b64

Sample Requests

POST http://<HostName>/ecx/v2/oauth/token

Password as plain text:

```
{
  "grant_type": "client_credentials",
  "user_name": "tempuser1",
  "user_password": "xxxxxxx",
  "client_id": "QWERTY1234567abcdefg",
  "client_secret": "tstCLNT123scr1"
}
```

Password encoded with md5 and then b64:

```
{
  "grant_type": "password",
  "user_name": "tempuser1",
  "user_password": "xxxxxxxxxxx",
  "client_id": "QWERTY1234567abcdefg"
}
```

20

-continued

```
"client_secret": "tstCLNT123scr1",
"password_encoding": "md5-b64"
}
```

Response:

		access_token
Description		The access token that must be passed in the HTTP header to access all API's
Type		string
Required		Yes
Default		None
Example		HihiOtaY2JAT0QaTFaYYyzHOqqmb
		token_timeout
Description		Timeout for the access token in seconds
Type		string
Required		Yes
Default		None
Example		3599
		user_name
Description		User Name
Type		string
Required		Yes
Default		None
Example		username
		token_type
Description		Type of access token
Type		string
Required		Yes
Default		Bearer
Example		Bearer
		refresh_token
Description		Refresh token that can be used for obtaining a new access token
Type		string
Required		No
Default		None
Example		QvJdZg7nMSTNYBfeDLgECpe5b9FvgWgdpZRww4u0nZ
		refresh_token_timeout
Description		Timeout for the refresh token in seconds
Type		string
Required		No
Default		None
Example		86376

Sample Response:

```
HTTP/1.1 200 OK
API-Version: v1
Content-Type: application/json
Accept: application/json
{
  "access_token": "HihiOtaY2JAT0QaTFaYYyzHOqqmb",
  "token_timeout": "3599",
  "user_name": "tempuser1",
  "token_type": "Bearer",
  "refresh_token": "QvJdZg7nMSTNYBfeDLgECpe5b9FvgWgdpZRww4u0nZ",
  "refresh_token_timeout": "86376"
}
```

21

Error Code in Response:

HTTP Code	Error Code	Error Description
400	40010	Invalid value for grant_type. The acceptable value is "password"
401	40101	Authentication failed. Invalid username or password
401	40103	Invalid API Key
406		Not Acceptable
415		Unsupported Media Type
500		Internal Server Error

POST Refresh Token: Description: This API allows developer to refresh existing OAuth Token issued which will expire otherwise within 60 minutes. A valid refresh token is needed to retrieve a new successful authentication access token that will be returned as part of the response.

Request

Request URI: POST http://<HostName>/oauth2/v1/refreshaccesstoken

Filter Parameters:

None

Request Headers:

None

Request Fields:

	grant_type
Description	OAuth grant operation. Acceptable values: refresh_token.
Type	String
Required	Yes
Default	None
Example	Password
	client_id
Description	API Consumer Key
Type	String
Required	Yes
Default	None
Example	QWERTY1234567afgaaaa
	refresh_token
Description	Refresh token that can be used for obtaining a new access token
Type	string
Required	YES
Default	None
Example	5f752714hsdf07a3e41c2a3311f514e1

Sample Requests

```
POST http://<HostName>/oauth2/v1/refreshaccesstoken
Refresh Token
{
  "grant_type": "refresh_token",
  "client_id": "QWERTY1234567abcdefg",
  "client_secret": "tstCLNT123scrt",
  "refresh_token": "5f752714hsdf07a3e41c2a3311f514e1"
}
```

Response:

Response Fields:

	access_token
Description	The access token that must be passed in the HTTP header to access all API's
Type	string
Required	Yes

22

-continued

Default	None
Example	HihiOtaY2JAT0QaTFaYYyzHOqqmb
5	token_timeout
Description	Timeout for the access token in seconds
Type	string
Required	Yes
Default	None
Example	3599 (1 hr)
10	user_name
Description	User Name
Type	string
Required	Yes
Default	None
Example	Username "adrew"
15	token_type
Description	Type of access token
Type	string
Required	Yes
Default	Bearer
Example	Bearer
20	refresh_token
Description	Refresh token that can be used for obtaining a new access token
Type	string
Required	No
Default	None
Example	QvJdZg7nMSTNYBfeDLgECpe5b9FvgWgdpZRww4u0nZ
25	refresh_token_timeout
Description	Timeout for the refresh token in seconds
Type	string
Required	No
Default	None
Example	86376
30	
Description	Timeout for the refresh token in seconds
Type	string
Required	No
Default	None
Example	86376
35	
Resource: Metros	
Description: Metros in which Cloud Exchange services are offered.	
40	
	HTTP Method
	Request URI
45	GET
	/ecx/v1/metros
GET Metros:	
Description: This implementation of the GET operation returns a list of all metros where either the user has ports or cloud exchange is enabled.	
50	
Request	
Request URI: GET http://<HostName>/ecx/v1/metros	
Filter Parameters:	
55	
	cloud_exchange_enabled
Description	Filter the results to get metros where Cloud Exchange is enabled. If this parameter is not included the result contains all the metros where user has port or Cloud Exchange is enabled
60	Acceptable value: true
Type	Boolean
Required	No
Default	None
Example	True
65	

Request Headers:

Header Attribute	Description
Authorization	Required. Specify the OAuth Bearer token

Sample Request

GET http://<HostName>/ecx/v1/metros?cloud enable=true

Response:

Response Fields:

metros	
Description	List of metros
Type	List
Required	Yes
Default	None
Example	None
name	
Description	Metro Name
Type	string
Required	Yes
Default	None
Example	Singapore
code	
Description	Metro Code
Type	string
Required	Yes
Default	None
Example	SG

Sample Response:

```
Content-Type: application/json
{
  "metros": [
    {
      "code": "SV",
      "name": "Silicon Valley",
    },
    {
      "code": "SG",
      "name": "Singapore"
    }
  ]
}
```

Error Code in Response:

HTTP Status		
Code	Error Code	Error Description
400	40001	Invalid Parameter Value
401	40102	Token Expired. Login again
401	40104	Invalid Access Token
401	40105	User doesn't have sufficient privilege to perform the operation
406		Not Acceptable
415		Unsupported Media Type
500		Internal Server Error

Resource: Cloud Services

Description: Cloud Services at cloud exchange 100

HTTP Method	Request URI
GET	/ecx/v1/cloudservices /ecx/v1/cloudservices/{cloud_service_name}

GET Cloud Services

Description: This implementation of the GET operation returns a list of all Cloud Services at cloud service exchange 100.

Request

RequestURI: GET http://<HostName>/ecx/v1/cloudservices,

GET http://<HostName>/ecx/v1/cloudservices/{cloud_service_name}

Filter Parameters:

None

Request Headers:

Header Attribute	Description
Authorization	Required. Specify the OAuth Bearer token

Sample Request

GET http://<HostName>/ecx/v1/cloudservices

Response:

Response Fields:

cloud_services	
Description	A list of a Cloud Services
Type	List
Required	Yes
Default	None
Example	None
name	
Description	Cloud Service Name
Type	string
Required	Yes
Default	None
Example	None
metros	
Description	A list of Metros served by the cloud service
Type	List
Required	Yes
Default	None
Example	None
name	
Description	Metro Name
Type	string
Required	Yes
Default	None
Example	Singapore
code	
Description	Metro Code
Type	string
Required	Yes
Default	None
Example	SG
ibxs	
Description	A list of IBX names in the metro. In Internet Business Exchange or "IBX" is a network-neutral data center and may represent an example of a cloud exchange or cloud exchange point, as described herein.
Type	List
Required	Yes
Default	None
Example	None

Sample Response:

```

HTTP/1.1 200 OK
Content-Type: application/json
{
  "cloud_services": [
    {
      "name": "CSPI",
      "metros": [
        {
          "code": "SG",
          "name": "Singapore",
          "ibxs": [
            "SV1",
            "SV2"
          ]
        }
      ]
    }
  ]
}
    
```

Error Code in Response:

HTTP Status Code	Error Code	Error Description
401	40102	Token Expired. Login again
401	40104	Invalid Access Token
401	40105	User doesn't have sufficient privilege to perform the operation
406		Not Acceptable
415		Unsupported Media Type
500		Internal Server Error

Buyer APIs

In this section, we describe the APIs that are relevant to a buyer.

Resource: Ports

Description: Ports on the Cloud Exchange Switch Fabric

HTTP Method	Request URI
GET	/ecx/v1/ports /ecx/v1/ports/{port_name}

GET Ports:

Description: This implementation of the GET operation returns a list of all ports owned by the authenticated sender of the request. The ports can be filtered by metro and IBX Name. If no ports matching the criteria are found then a 204 HTTP code response is returned without a payload.

Request

Request URI:

GET http://<HostName>/ecx/v1/ports?metro_code=SV&ibx_name=SV1

Filter Parameters:

metro_code	
Description	The code of a Metro. If no Metro Code is provided ports in all metros are returned as part of the response
Type	String
Default	None
Example	SV
Required	No

ibx_name	
Description	Equinix IBX location name. If no IBX name is provided then ports in all IBXs are returned
Type	String
Default	None
Example	SV1
Required	No

-continued

bandwidth	
Description	The bandwidth of the port. If no bandwidth is provided then ports with any bandwidth capacity are returned.
Type	String
Default	None
Example	1 G
Required	No

encapsulation	
Description	The encapsulation of the port.
Type	String
Default	None
Example	Dot1Q or QinQ (case insensitive)
Required	No

is_buyout	
Description	The type of port, standard or buyout.
Type	String
Default	None
Example	Y or N (case insensitive)
Required	No

Request Headers:

Header Attribute	Description
Authorization	Required. Specify the OAuth Bearer token

Sample Request

```

30 GET http://<HostName>/ecx/v1/ports?metro_code=SV&ibx=SV1
GET http://<HostName>/ecx/v1/ports?bandwidth=100
GET http://<HostName>/ecx/v1/ports?encapsulation=Dot1Q
35 GET http://<HostName>/ecx/v1/ports?is_buyout=Y
    
```

Response Fields:

ports	
Description	List of Ports
Type	List
Required	Yes
Default	None
Example	None

name	
Description	Name of Port
Type	String
Required	Yes
Default	None
Example	GSE_QA-R-EE-02

metro_code	
Description	Code of the metro in which the port is located
Type	String
Required	yes
Default	None
Example	SV

metro_name	
Description	Name of the metro in which the port is located
Type	String
Required	yes
Default	None
Example	Silicon Valley

ibx_name	
Description	Name of the IBX in which the port is located
Type	String
Required	yes

-continued

Default	None
Example	SV1
bandwidths	
Description	The bandwidths of the port (Array of values for Lagged Ports)
Type	Array
Default	None
Example	10 G, 10 G
Required	No
encapsulation	
Description	Port encapsulation
Type	string
Default	None
Example	dot1q or QinQ
Required	Yes
is_buyout	
Description	Buyout Port or Standard Port
Type	string
Required	yes
Default	None
Example	Y or N
cross_connect_ids	
Description	Cross connect Serial numbers
Type	Array
Required	Yes
Default	None
Example	11111111, 23222

Sample Response 1:

```

HTTP/1.1 200 OK
Content-Type: application/json
{
  "ports": [
    {
      "name": "GSE_QA-R-EE-02",
      "metro_code": "SV",
      "metro_name": "Silicon Valley",
      "ibx_name": "SV1"
    },
    {
      "name": "GSE_QA-R-EE-01",
      "metro_code": "SG",
      "metro_name": "Singapore",
      "ibx_name": "SG1"
    }
  ]
}
    
```

Sample Response 2:

```

HTTP/1.1 200 OK
Content-Type: application/json
{
  "ports": [
    {
      "bandwidth": "10 G",
      "bandwidths": [
        "10 G", "10 G" ],
      "cross_connect_ids": [
        "123456"
      ],
      "encapsulation": "QinQ",
      "ibx_name": "SV3",
      "is_buyout": "N",
      "metro_code": "SV",
      "metro_name": "BAYM",
      "name": "QinQVirtualPort"
    }
  ]
}
    
```

Error Code in Response:

HTTP Status Code	Error Code	Error Description
400	40001	Invalid Parameter Value
401	40102	Token Expired. Login again
401	40104	Invalid Access Token
406		Not Acceptable
415		Unsupported Media Type
500		Internal Server Error

Resource: Seller Services
 Description: Seller Services at the Cloud Exchange

HTTP Method	Request URI
GET	/ecx/v1/sellerservices /ecx/v1/sellerservices/{seller_service_name}

GET Seller Services

Description: This implementation of the GET operation returns a list of all Seller Services at the Cloud Exchange.

Request

Request URI: GET http://<HostName>/ecx/v1/sellerservices,

GET http://<HostName>/ecx/v1/sellerservices/{seller_service_name}

Filter Parameters: Filter the results by metro. If this parameter is not included, the response contains all the seller services at the Cloud Exchange

Sample Request

GET http://<HostName>/ecx/v1/sellerservices/{seller_service_name}http://<HostName>/ecx/v1/sellerservices?metro_code=SV

Response:

Response Fields:

seller_services	
Description	A list of a Seller
Type	List
Required	Yes
Default	None
Example	None
allow_custom_speed	

Description The buyer can see all the seller services in a given metro that allow custom speeds if the buyer has a buyout port. The values that the response will include can be either 'Y' or 'N'.

Type	String
Required	Yes
Default	
Example	Y or N

availability_status: The availability status of the Service Profile as 'In Trial Testing' or Available for orders.

encapsulation	
Description	Port encapsulation
Type	String
Default	None
Example	dot1q or QinQ
Required	Yes

require_redundancy

require_redundancy	
Description	This will define if a secondary virtual circuit creation is required when buyer requests a virtual circuit from this seller service provider. If yes, buyer will have to provide primary and secondary both secondary port and VLAN IDs. Acceptable values are Y and N.
Type	string
Required	Yes
Default	None
Example	TRUE

standard_speeds: The allowed standard speeds associated with the service profile when custom speed is not allowed by the seller.

seller service name

metros: A list of Metros served by the seller. Metro name.

Metro code. A list of IBX names in the metro.

Sample Response:

```

HTTP/1.1 200 OK
Content-Type: application/json
{
  "seller_services": [
    {
      "allow_custom_speed": "N",
      "encapsulation": "Dot1q",
      "metros": [
        {
          "code": "DC",
          "ibxs": [
            "DC5",
            "DC6"
          ],
          "name": "Ashburn"
        },
        {
          "code": "SV",
          "ibxs": [
            "SV1"
          ],
          "name": "SiliconValley"
        }
      ],
      "name": "test1",
      "availability_status": "in_trial_testing",
      "require_redundancy": "N",
      "standard_speeds": [
        "Upto10G",
        "Upto200MB",
        "Upto500MB",
        "Upto1G"
      ]
    }
  ]
}
    
```

Resource: User Assets
 Description: Get details of assets owned by a buyer in a given metro location.

HTTP Method	Request URI
GET	/ecx/v1/assets

GET Assets
 Description: This implementation of the GET operation for buyers returns a list of all buyer assets including ports and virtual circuits in a given metro.

Request
 Request URI: GET http://<HostName>/ecx/v1/assets
 Filter Parameters:

metro_code	
Description	Filter the results by metro.
Type	String
Required	Yes
Default	None
Example	SV

asset_type	
Description	Filter the results by the types of assets. Buyer: For getting assets that the user has as a buyer
Type	String
Required	Yes
Default	None
Example	buyer

Request Headers:

Header Attribute	Description
Authorization	Required. Specify the Oauth Bearer token

Request
 GET http://<HostName>/ecx/v1/assets?metro_code=SV&asset_type=buyer
 Response:
 Response Fields:

buyer_assets	
Description	Buyer related assets of the user in the metro
Type	Object
Required	Yes
Default	None
Example	None

seller_assets	
Description	Seller related detail of the user in the metro
Type	Object
Required	Yes
Default	None
Example	None

ports	
Description	List of Ports.
Type	List
Required	Yes
Default	None
Example	None

name	
Description	Name of the Port
Type	String
Required	Yes
Default	None
Example	GSE_QA-R-EE-cross_connect_ids

metro_code	
Description	Cross connect Serial
Type	Array
Required	Yes
Default	None
Example	1111111100

Description	Code of the metro in which the port is
Type	String
Required	Yes
Default	None
Example	SV

31

-continued

metro_name	
Description	Name of the metro, in which the port is
Type	String
Required	Yes
Default	None
Example	Silicon Valley
ibx_name	
Description	Name of the IBX in which the port is
Type	String
Required	Yes
Default	None
Example	SV1
bandwidths	
Description	The bandwidths of the port (Array of values for Lagged Ports)
Type	Array
Default	None
Example	1 G, 1 G
Required	No
encapsulation	
Description	Port encapsulation
Type	String
Default	None
Example	dot1q or QinQ
Required	Yes
is_buyout	
Description	Buyout Port or Standard Port
Type	String
Required	Yes
Default	None
Example	Y or N
virtual_circuits	
Description	List of virtual circuits for each
Type	List
Required	Yes
Default	None
Example	None
<p>id Id of the virtual circuit. This id is required to perform operations on the virtual circuit APIs like DELETE or GET Virtual Circuit</p>	
redundant_id	
Description	Virtual circuit ID associated with the redundant virtual circuit
Type	string
Required	Yes
Default	None
Example	4D34239266A3952695956B
<p>cross_connect_id [Deprecated, instead refer to field 'Ports'.cross_connect_ids']</p>	
Description	Id of the physical port
Type	String
Required	Yes
Default	None
Example	1111111100
<p>port_speed [Deprecated, instead refer to field 'Ports'.port_speeds']</p>	
Description	The capacity of the port, e.g., 1
Type	String
Required	Yes
Default	None
Example	1000000000
name	
Description	Virtual circuit name
Type	String
Required	Yes

32

-continued

Default	None
Example	API Test VC1
created_by	
Description	Name of the user who has been created the virtual
Type	String
Required	Yes
Default	None
Example	First Name Last Name
email	
Description	email of the user who has been created the virtual circuit
Type	String
Required	Yes
Default	None
Example	x@y.com
created_date	
Description	Date and time when the virtual circuit has been created
Type	String
Required	Yes
Default	None
Example	02-15-2014 21:58:20
seller_service_name	
Description	Name of the seller service profile for the virtual circuit
Type	String
Required	No
Default	None
Example	Direct Connect
<p>availability_status—The availability status of the Service Profile as 'In Trial Testing'</p>	
service_key	
Description	Service Key or Digital Authorization Key obtained from the Seller
Type	String
Required	Yes
Default	None
Example	xxxxxxxx-xxxx-xxxx-xxxx-xxxxxxxxxxxx
state	
Description	State of the virtual circuit
Type	String
Required	No
Default	None
Example	PROVISIONED
status	
Description	Status of the virtual circuit
Type	String
Required	No
Default	None
Example	BILLED
<p>55 Sample Response:</p>	
<p>HTTP/1.1 200 OK Content-Type: application/json</p>	
<pre>[{ "buyer_asset": { "ports": [{ "bandwidth": "1 G", "bandwidths": ["1 G, 1 G"] }] } }]</pre>	

35

-continued

state	
Description	State of the virtual circuit. Example possible values are "Being Provisioned", "Ordering", "Pending", "Available", "Not Provisioned", "Provisioned", "Pending Add", "Deleted" and "Pending Delete."
Type	string
Default	None
Example	PROVISIONED
Required	No
status	
Description	Status of the virtual circuit
Type	string
Required	No
Default	None
Example	BILLED
created_date	
Description	Date the virtual circuit is created
Type	string
Required	Yes
Default	None
Example	05/23/2014 01:21:54
created_by	
Description	The user who created the virtual circuit
Type	string
Required	yes
Default	None
Example	tempuser1
email	
Description	Email of the user
Type	string
Required	Yes
Default	None
Example	test@cloudexchange.com
seller_port	
Description	Seller side port
Type	string
Required	yes
Default	None
Example	GSE_QA-SJC-port-CIS-2-SEC-A
metro_code	
Description	Code of the metro in which this Virtual Circuit is located
Type	string
Required	Yes
Default	None
Example	SV
ibx_name	
Description	Name of the metro in which this Virtual Circuit is located
Type	string
Required	Yes
Default	None
Example	SV1
seller_service_name	
Description	Name of the seller service profile for the virtual circuit
Type	string
Required	No
Default	None
Example	Direct Connect
metadata	
Description	This object can be used by users to enter metadata information about their VCs. This is not a mandatory object of fields. If the buyer passed metadata information during VC creation, the buyer can retrieve this metadata information during GET Virtual Circuit operation. Only 5 key-value pairs can be passed in this metadata object. For particular sellers, the metadata object shall be null.
Type	object
Required	No

36

-continued

Default	None									
Example	None									
5	"key:value"									
Description	The key and associated value that the API user can pass in the metadata object.									
Type	string									
Required	No									
Default	None									
Example	None									
10										
15	Sample Response:									
20	<pre> HTTP/1.1 200 OK Content-Type: application/json { "virtualcircuits": [{ "id": "4D34239266A3952695956A", "name": "Sample Test VC-7", "buyer_port": "GSE_QA-R-EE-01 ", "cross_connect_id": "14395166", "port_speed": "1G", "cloud_service_name": "CSP_A_1", "service_key": "xxxxxxxx-xxxx-xxxx-xxxx-xxxxxxxxxxxx", "buyer_vlan": "2004.*", "bandwidth": "Up to 200MB", "state": "PROVISIONED", "status": "BILLED", "created_date": "05/23/2014 01:21:54", "created_by": "testuser1", "email": "test@cloudexchange.com", "seller_port": "GSE_QA-SJC-06GMR-CIS-2-SEC-A", "metro_code": "SV", "ibx_name": "SV1" }, { "seller_service_name": "cspcreatetest", "metadata": { "key1": "value1", "key2": "value2", "key3": "value3", "key4": "value4", "key5": "value5" } }, { "id": "1432", "name": "Steve CSP_A Test VC-5", "buyer_port": "GSE_QA-R-EE-01", "cross_connect_id": "14395166", "port_speed": "1G", "cloud_service_name": "CSP_A_1", "service_key": "xxxxxxxx-xxxx-xxxx-xxxx-xxxxxxxxxxxx", "buyer_vlan": "2004.*", "bandwidth": "Up to 200MB", "state": "PROVISIONED", "status": "BILLED", "created_date": "05/23/2014 01:21:54", "created_by": "testuser1", "email": "test@cloudexchange.com", "seller_port": "GSE_QA-SJC-1234-CIS-2-SEC-A", "metro_code": "SV", "ibx_name": "SV1" }] } </pre>									
25										
30										
35										
40										
45										
50										
55										
60	Error Code in Response:									
65	<table border="1"> <thead> <tr> <th>HTTP Status Code</th> <th>Error Code</th> <th>Error Description</th> </tr> </thead> <tbody> <tr> <td>401</td> <td>40102</td> <td>Token Expired, Login again</td> </tr> <tr> <td>401</td> <td>40104</td> <td>Invalid Access Token</td> </tr> </tbody> </table>	HTTP Status Code	Error Code	Error Description	401	40102	Token Expired, Login again	401	40104	Invalid Access Token
HTTP Status Code	Error Code	Error Description								
401	40102	Token Expired, Login again								
401	40104	Invalid Access Token								

-continued

HTTP Status Code	Error Code	Error Description
401	40105	User doesn't have sufficient privilege to perform the operation
406		Not Acceptable
415		Unsupported Media Type
500		Internal Server Error

POST Virtual Circuits:

Description: Create Virtual Circuit.

Request

Request Headers:

Header Attribute	Description
Authorization	Required. Specify the OAuth Bearer token

Request URI: POST http://<hostname>/ecx/v1/virtualcircuits

Filter Parameters

None

Request Fields

metro_name	
Description	Name of the metro in which this Virtual Circuit is located
Type	string
Required	Yes
Default	None
Example	Silicon Valley

metro_code	
Description	Code of the metro in which this Virtual Circuit is located
Type	string
Required	Yes
Default	None
Example	SV

cloud_service_name	
Description	Name of the Cloud Service Profile. Depending on the cloud service selected the fields required in the payload will differ.
Type	string
Required	Yes
Default	None
Example	CSP_A_1

seller_service_name	
Description	Name of the Seller Service Profile. Depending on the seller service selected the fields required in the payload will differ.
Type	string
Required	Yes
Default	None
Example	Name provided by seller service provider

primary_vc_name	
Description	Primary virtual circuit name
Type	string
Required	Yes
Default	None
Example	twtca93

primary_port_name	
Description	Primary buyer Port name
Type	string
Required	Yes
Default	None
Example	GSE_QA-SJC-06GMR-CIS-2-SEC-A

-continued

secondary_vc_name	
5 Description	Secondary virtual circuit name
Type	String
Required	No
Default	None
Example	twtca94

secondary_port_name	
10 Description	Secondary buyer port name
Type	string
Required	No
Default	None
15 Example	GSE_QA-SJC-06GMR-CIS-2-SEC-A

secondary_vlan_id	
20 Description	Secondary buyer VLAN Id
Type	string
Required	No
Default	None
Example	188

service_key	
25 Description	Service Key obtained from the Cloud Service
Type	string
Required	Yes
Default	None
Example	xxxxxxxx-xxxx-xxxx-xxxx-xxxxxxxxxxxx

virtual_circuit_speed	
30 Description	Speed of the virtual circuit
Type	string
Required	Yes
Default	None
35 Example	200 MB

email	
40 Description	Email of the user
Type	string
Required	No
Default	None
Example	test@cloudexchange.com

45 Other example fields may include seller service provider account number, digital authorization key obtained from the seller service, border gateway protocol configuration number, the id of the virtual private gateway to a VPC, buyer peer ip (IP address assigned to buyer/client interface), IP address assigned to seller service provider interface, email of the user, metadata (as described above), key (This key, its associated value that the API user had passed in the metadata object during VC creation), and speed of the virtual circuit.

Seller Service Providers	Standard Port (Buyer)	Buyout Port (Buyer)
60 Seller A	200 MB, 500 MB	50 MB, 100 MB, 200 MB, 300 MB, 400 MB, 500 MB
Seller B	200 MB, 500 MB, 1 G	200 MB, 500 MB, 1 G & 10 G (only when the buyer has a 10 G buyout port)
Other Seller Service Profiles (Allowing custom speed)	200 MB, 500 MB, 1 G	200 MB, 500 MB, 1 G or integer number, no decimals, between 1 and <= buyer physical port speed

Sample Request

```
POST http://<HostName>/ecx/v1/virtualcircuits
Authorization: Bearer <accessToken>
Accept: application/xml or application/json
{
  "metro_name":"Silicon Valley",
  "metro_code":"SV",
  "cloud_service_name":" CSP_A_1",
  "primary_vc_name":"twtca93",
  "primary_port_name":" GSE_QA-SJC-06GMR-CIS-2-SEC-A",
  "primary_vlan_id":"188",
  "secondary_vc_name":"twtcp94",
  "secondary_port_name":"GSE_QA-SJC-06GMR-CIS-2-SEC-B",
  "secondary_vlan_id":"188",
  "service_key":" xxxxxxxx-xxxx-xxxx-xxxx-xxxxxxxxxxxx", "virtual_circuit_speed":"Up
to 200MB",
  "email":"test@cloudexchange.com
  "metadata"
}
```

Response
Response Fields:

20

-continued

result	
Description	Result of the operation indicating whether it was successful. Valid values are SUCCESS and ERROR
Type	string
Required	Yes
Default	None
Example	SUCCESS
message	
Description	Success Message
Type	string
Required	Yes
Default	None
Example	Your Virtual Circuit request was successful

25

HTTP Status Code	Error Code	Error Description
401	40105	User doesn't have sufficient privilege to perform the operation
415		Unsupported Media Type
500		Internal Server Error

30

In some examples, APIs may be provided for deleting virtual circuits. The DELETE operation will remove the virtual circuit provided, a response with HTTP Code 200 is returned if operation is successful. If the virtual circuit belongs to certain seller service providers, those seller service provider will have to confirm the deletion of the virtual circuit.

35

Sample Request

```
DELETE http://<HostName>/ecx/v1/virtualcircuits/{virtual_circuit_id}
```

Other example fields may include "more info," primary virtual circuit id, secondary virtual circuit id.
Sample Response:

```
HTTP/1.1 201 CREATED
Location: 4D34239266A3952695956A
{
  "result": "SUCCESS"
  "message": "Your Virtual Circuit request was successful."
  "more_info": "https://api.developer.cloudexchange.com/docs/api/messages/xx"
}
```

Error Code in Response:

50 Sample Response:

HTTP Status Code	Error Code	Error Description
400	40002	The value of VLAN should be between 1 and 4095
400	40003	Cannot select the same port for Primary and Secondary Virtual Circuit
400	40004	Enter a value for all required fields
400	40005	The number of characters exceeded
400	40006	Cannot select the same name for Primary and Secondary Virtual Circuit
400	40007	Invalid Field Value
400	40009	Application specific error. Ex., duplicate VLAN Id
401	40102	Token Expired. Login again
401	40104	Invalid Access Token

55

```
HTTP/1.1 200 DELETED
{
  "result": "SUCCESS"
  "message": "Your Virtual Circuit has been deleted successfully."
  "more_info": ""
}
```

60

In some examples, APIs may be provided for PATCH enable connection. This implementation of the PATCH operation lets the users to enable virtual circuit if the seller requires additional step of authentication before enabling the buyer connection request.

Sample Response:

```
HTTP/1.1 201 CREATED
{
  "result": "SUCCESS",
  "message": "Connection enabling request successful"
  "more_info": ""
}
```

In some examples, APIs are provided for Seller Service Profiles to be created by sellers in Cloud Exchange. Cloud Exchange sellers are required to define and set up their

service profiles for connectivity to their seller services. Sellers can create a profile for each discrete service that they offer.

5 In some examples, a “GET virtual circuit payload metadata” implementation of the GET operation returns the payload metadata required to create virtual circuits for a given seller service profile.

Sample Request

GET http://<HostName>/ecx/v1/sellerserviceprofiles/
10 CloudSigma Profile/metadata

Sample Response:

```
HTTP/1.1 200 OK
Content-Type: application/json
{
  "fields": [
    {
      "description": "Code of the metro in which this virtual circuit will be created",
      "name": "metro_code",
      "type": "string"
    },
    {
      "description": "Seller Service Name",
      "name": "seller_service_name",
      "type": "string"
    },
    {
      "description": "Primary virtual circuit name",
      "name": "primary_vc_name",
      "type": "string"
    },
    {
      "description": "Buyers primary port name",
      "name": "primary_port_name",
      "type": "string"
    },
    {
      "description": "Buyers primary VLAN Id",
      "name": "primary_vlan_id",
      "type": "string"
    },
    {
      "description": "Secondary virtual circuit name",
      "name": "secondary_vc_name",
      "type": "string"
    },
    {
      "description": "Buyers secondary port name",
      "name": "secondary_buyer_port_name",
      "type": "string"
    },
    {
      "description": "Buyers secondary VLAN Id",
      "name": "secondary_buyer_vlan_id",
      "type": "string"
    },
    {
      "description": "Service Key or Digital Authorization Key obtained from CSP",
      "name": "service_key",
      "type": "string"
    },
    {
      "description": "Speed of the virtual circuit",
      "name": "virtual_circuit_speed",
      "type": "string"
    },
    {
      "description": "Email of the user",
      "name": "email",
      "type": "string"
    }
  ]
}
```

Seller APIs
Resource: Ports
Description: Ports on the Cloud Exchange Switch Fabric

HTTP Method	Request URI
GET	/ecx/v1/ports /ecx/v1/ports/{port_name}

GET Ports:

Description: This implementation of the GET operation returns a list of all ports owned by the authenticated sender of the request. The ports can be filtered by metro, and IBX Name. If no ports matching the criteria are found then a 204 HTTP response is returned without a payload.

Request

Request URI:

GET http://<HostName>/ecx/v1/ports?metro_code=SV&ibx_name=SV1

Filter Parameters:

metro_code	
Description	Code of a Metro. If no Metro Code is provided ports in all metros are returned as part of the response
Type	string
Required	No
Default	None
Example	SV

ibx_name	
Description	Equinix IBX location name (IBX). If no IBX is provided, the method returns ports in all IBXs
Type	string
Required	No
Default	None
Example	SV1

bandwidth

The bandwidth of the port. If no bandwidth is provided then ports with any bandwidth capacity are returned.

Request Headers:

Header Attribute	Description
Authorization	Required. Specify the OAuth Bearer token

Sample Request:

GET http://<HostName>/ecx/v1/ports?metro_code=SV&ibx=SV1

Response

Response Fields:

ports	
Description	List of Ports.
Type	List
Required	Yes
Default	None
Example	

name	
Description	Name of the Port
Type	string
Required	Yes
Default	None
Example	GSE_QA-R-EE-02

-continued

metro_code	
Description	Code of the metro in which the port is located
Type	string
Required	yes
Default	None
Example	SV

metro_name	
Description	Name of the metro, in which the port is located
Type	string
Required	yes
Default	None
Example	Silicon Valley

ibx_name	
Description	Name of the IBX in which the port is located
Type	string
Required	yes
Default	None
Example	SV1

Other example response fields: bandwidths, encapsulation, is buyout, cross_connect_ids (cross connect serial numbers).

Sample Response:

```
HTTP/1.1 200 OK
Content-Type: application/json
{
  "ports": [
    {
      "name": "GSE_QA-R-EE-02",
      "metro_code": "SV",
      "metro_name": "Silicon Valley",
      "ibx_name": "SV1"
    },
    {
      "name": "GSE_QA-R-EE-01",
      "metro_code": "SG",
      "metro_name": "Singapore",
      "ibx_name": "SG1"
    }
  ]
}
```

Error Code in Response:

HTTP Status Code	Error Code	Error Description
400	40001	Invalid Parameter Value
401	40102	Token Expired, Need to login again.
401	40104	Invalid Access Token
401	40105	User doesn't have sufficient privilege to perform the operation
406		Not Acceptable
415		Unsupported Media Type
500		Internal Server Error

Resource: seller service profiles

Description: Seller Service Profiles created by sellers in Equinix Cloud Exchange. Equinix Cloud Exchange sellers are required to define and set up their service profiles for connectivity to their seller services. Sellers can create a profile for each discrete service that they offer.

HTTP Method	Request URI
GET	/ecx/v1/sellerserviceprofiles
GET	/ecx/v1/sellerserviceprofiles/{profile_name}
GET	/ecx/v1/sellerserviceprofiles/{profile_name}/metadata

-continued

HTTP Method	Request URI
POST	/ecx/v1/sellerserviceprofiles
PUT	/ecx/v1/sellerserviceprofiles /{profile_name}/ports
DELETE	/ecx/v1/sellerserviceprofiles /{profile_name}/ports

POST seller service profiles. This implementation of the POST operation creates a new seller service profile for the logged in user. Example request fields include: name, availability status (The availability status of the Service Profile as ‘In Trial Testing’ or ‘Available for Orders’), virtual circuit label, service type, api available (Indicates whether API integration is available for this service. The API integration allows completing the virtual service provisioning. Acceptable values are TRUE and FALSE.), The authorization key label (This is what the seller organization calls the authorization key), The port encapsulation method used for seller side, Type of seller services this connection can reach, Require redundancy—This will define if a secondary virtual circuit creation is required when buyer requests a virtual circuit from this seller service provider. If yes, buyer will have to provide both primary and secondary port and VLAN IDs. Acceptable values are TRUE and FALSE; secondary_vlan_same—If this field has a value of “TRUE” the buyer will be forced to provide the same vlan id for both primary and secondary virtual circuits; capture_buyerpeer_ip—Indicates whether to capture buyer peer IP address. Acceptable values are TRUE and FALSE; Capture Buyer BGP ASN; Capture Virtual Private Gateway; capture_sellerpeer_ip—Indicates whether to capture buyer peer IP address. Acceptable values are TRUE and FALSE.

Other example request fields include: The Bandwidth Threshold Alert Contacts. Multiple email address can be separated by comma. notification contacts: Contacts that will be notified of virtual circuit requests and deletions. alert percentage: Bandwidth threshold per port; The ports the seller service provider will enable for buyers to establish virtual circuit connection; The virtual circuit speeds offered; allow_custom_speed: The seller can choose to allow buyers to select custom speeds if the buyer has a buyout port.

Sample Request

```
POST http://<HostName>/ecx/v1/sellerserviceprofiles
{
  "name": "TestService123", "availability_status": "In_Trial_Testing",
  "virtual_circuit_label": "Virtual Connection Name", "service_type":
  "Seller Service Connectivity", "api_available": "TRUE",
  "auth_key_label": "Authorization Key",
  "port_encapsulation": "QNQ", "connection_service_type":
  "Hybrid", "require_redundancy": "TRUE",
  "secondary_vlan_same": "TRUE", "capture_buyer_bgp_asn":
  "FALSE", "capture_buyer_peer_ip": "TRUE",
  "capture_seller_peer_ip": "TRUE",
  "capture_virtual_private_gateway": "TRUE",
  "threshold_alert_contacts": "user1@equinix.com,user@equinix.com",
  "notification_contacts": "user2@equinix.com", "allow_custom_speed": "TRUE",
  "ports": [
    "GSE_Test-02",
    "GSE_Test-03"
  ],
  "vlan_speeds": [
    "Up to 200MB",
    "Up to 500MB",
    "Up to 1G"
  ],
  "alert_percentage": "90"
}
```

Response Fields:

result	
5 Description	Result of the operation indicating whether it was successful. Valid values are SUCCESS and ERROR
Type	String
Require	Yes
Default	None
10 Exmpl	SUCCESS
message	
Description	Success Message
Type	string
Require	Yes
Default	None
15 Exmpl	The Seller Service Profile has been Created
more_info	
Description	Additional
Type	string
20 Require	No
Default	None
Example	

Sample Response:

```
HTTP/1.1 200 Created
{
  "result": "SUCCESS",
  "message": "The Seller Service Profile has been Created successfully",
  "more_info": ""
}
```

POST Ports to Seller Service Profiles

Description: This implementation of the POST operation enables given ports (owned by the user) for seller exchange service offering. In particular, the operation adds ports to an existing seller service profile.

Note: A Seller Service Profile will have to be Approved for this operation to be possible. Rejected or Pending Seller Service Profiles will not be allowed to be edited and ports can't be added until it is in Approved status.

Request URIs:
 POST
 http://<HostName>/ecx/v1/sellerserviceprofiles/{profile_5
 name}/ports

As another example, a DELETE operation will remove the port from the Seller Service Profile, a response with HTTP Code 200 is returned if operation is successful. There cannot be an active VC associated to the port which is being deleted, if a virtual circuit already exists on the port, an error

message is displayed indicating that there is an existing virtual circuit on the port.

At least one port must be present in a service profile.

As another example, a PUT operation will be used to edit the existing Seller Service Profile, a response with HTTP Code 200 is returned if operation is successful. The profile state (Approved or Pending Approval) will not change during the Edit operation.

The fields that can be updated in the put operation are:

Attribute	Req	Comments
Name	Required	If the input matches the existing value in DB then no change. If does not match then the input value will be updated in DB.
availability_status	Required	If the input matches the existing value in DB then no change. If does not match then the input value will be updated in DB.
virtual_circuit_label	Required	If the input matches the existing value in DB then no change.
service_type	Required	If the input matches the existing value in DB then no change.
api_available	Required	If the input matches the existing value in DB then no change. If does not match then the input value will be updated in DB.
auth_key_label	Required	If the input matches the existing value in DB then no change. If does not match then the input value will be updated in DB.
connection_service_type	Required	If the input matches the existing value in DB then no change. If does not match then the input value will be updated in DB.
require_redundancy	Required	If the input matches the existing value in DB then no change. If does not match then the input value will be updated in DB.
secondary_vlan_same	Required	If the input matches the existing value in DB then no change.
capture_buyer_bgp_asn	Required	If the input matches the existing value in DB then no change. If does not match then the input value will be updated in DB.
capture_buyer_peer_ip	Required	If the input matches the existing value in DB then no change. If does not match then the input value will be updated in DB.
capture_seller_peer_ip	Required	If the value matches the existing value in DB then no change. If does not match then the input value will be updated in DB.
capture_virtual_private_gateway	Required	If the value matches the existing value in DB then no change. If does not match then the input value will be updated in DB. Valid values are 'TRUE' or 'FALSE'.
alert_percentage	Optional	The range is from 0 to 99. If not provided then threshold_alert_contacts must also be NULL/EMPTY.
threshold_alert_contacts	Optional	If alert_percentage is provided then threshold_alert_contacts must also be NOT-NULL and provided with valid array of alert contacts.
notification_contacts	Required	Update all the threshold_alert_contacts from input into the DB. Existing contacts will be removed and overridden with the new input array.
ports	Required	Update all the ports from input into the DB. Existing ports will be removed and overridden with the new input array.
vlan_speeds	Required	Update all the vlan_speed values from input into the DB. Existing speeds will be removed and overridden with the new input array.
allow_custom_speed	Required	If the value matches the existing value in DB then no change. If does not match then the input value will be updated in DB. Valid values are 'TRUE' or 'FALSE'.

As another example, “GET My Seller Service Profiles” can be used by sellers to get a list of all seller service profiles they have created. This implementation of the GET operation returns a seller service profile passed as part of the profile_name path parameter. Filtering by seller service status is also available by setting a parameter.

Sample Request:

GET http://<HostName>/ecx/v1/sellerserviceprofiles (get all my seller service profiles)

GET http://<HostName>/ecx/v1/sellerserviceprofiles/{profile_name} (get seller service profile by name)

GET http://<HostName>/ecx/v1/sellerserviceprofiles/{profile_name}?status={valid status} (get seller service profile by name and status)

GET http://<HostName>/ecx/v1/sellerserviceprofiles?status={valid status} (get seller service profile by status)

As another example, GET assets can be used by sellers to get details of assets owned by a Seller in a given metro location. This implementation of the GET operation for sellers returns a list of all assets including ports and virtual circuits in a given metro. A seller can also be a Buyer and hence the ‘asset type’ for a seller can be both ‘buyer’ and ‘seller’.

Resource: Virtual Circuits

Description: Virtual Circuits

HTTP Method	Request URI
GET	/ecx/v1/virtualcircuits
POST	/ecx/v1/virtualcircuits/{virtual_circuit_id}

GET Virtual Circuits:

Description: This implementation of the GET operation returns a list of virtual circuits owned by the user. The virtual circuits can be filtered based on their status. If no virtual circuits are found matching the criteria, a response with HTTP Code 204 is returned with no payload.

Request

Request URI(s):

GET http://<HostName>/ecx/v1/virtualcircuits?pending=add

Filter Parameters:

pending

Description: Status of the virtual circuits. Possible values are add

To get all the virtual circuits that are created by a buyer but not yet accepted by the seller delete

To get all the virtual circuits that are deleted by a buyer but not yet accepted by the seller

Type	string
Required	No
Default	None
Example	add

Request Headers:

Header Attribute	Description
Authorization	Required. Specify the Oauth Bearer token

Request Fields:

None

Sample Request:

GET http://<HostName>/ecx/v1/virtualcircuits?pending=add

Response

Response Fields

10		id
	Description	Virtual circuit ID
	Type	string
	Required	Yes
	Default	None
15	Example	4D34239266A3952695956A
		name
	Description	Name of the virtual circuit
	Type	string
	Required	Yes
	Default	None
20	Example	Steve CSP_A Test VC-7
		buyer_port
	Description	buyer side port id
	Type	string
	Required	Yes
	Default	None
25	Example	"GSE_QA-R-EE-01
		cross_connect_id
	Description	Id of the physical port
	Type	string
	Required	Yes
	Default	None
30	Example	11111111
		port_speed
	Description	The capacity of the port eg: 1 G or 10 G
	Type	string
	Required	Yes
	Default	None
35	Example	1 G
		cloud_service_name
	Description	Cloud Service Name
	Type	string
	Required	Yes
	Default	None
40	Example	CSP_A_1
		service_key
	Description	Service Key obtained from the Cloud Service
	Type	string
	Required	Yes
	Default	None
45	Example	xxxxxxxx-xxxx-xxxx-xxxx-xxxxxxxxxxxx
		buyer_vlan
	Description	Buyer side VLAN Id
	Type	string
	Required	Yes
	Default	None
50	Example	2004.*
		bandwidth
	Description	Bandwidth
	Type	string
	Required	Yes
	Default	None
60	Example	200 MB
		status
	Description	Status of the virtual circuit
	Type	string
	Required	No
	Default	None
65	Example	BILLED

51

-continued

created_date	
Description	Date the virtual circuit is created
Type	string
Required	Yes
Default	None
Example	05/23/2014 01:21:54
created_by	
Description	The user who created the virtual circuit
Type	string
Required	Yes
Default	None
Example	tempuser1
email	
Description	Email of the user
Type	string
Required	Yes
Default	None
Example	test@cloudexchange.com
seller_port	
Description	Seller Port
Type	string
Required	No
Default	None
Example	GSE_QA-SJC-06GMR-CIS-2-SEC-A
metro_code	
Description	Code of the metro in which this Virtual Circuit is located.
Type	string
Required	Yes
Default	None
Example	SV
ibx_name	
Description	Name of the IBX in which this Virtual Circuit is located
Type	string
Required	Yes
Default	None
Example	SV1

Other example fields such as those included above in other examples may be used.

Sample Response:

```

HTTP/1.1 200 OK
Content-Type: application/json
{
  "virtualcircuits": [
    {
      "id": "4D34239266A3952695956A",
      "name": "Test Virtual Circuit",
      "buyer_port": "GSE_QA-R-EE-01",
      "cross_connect_id": "11111111",
      "portspeed": "1G",
      "cloud_service_name": "CSP_A_1",
      "service key": "xxxxxxxx-xxxx-xxxx-xxxx-xxxxxxxxxxxx",
      "buyer_vlan": "2004.*",
      "bandwidth": "Up to 200MB",
      "status": "BILLED",
      "created_date": "05/23/2014 01:21:54",
      "created_by": "temp user",
      "email": "test@cloudexchange.com",
      "seller_port": "sellerport",
      "metro_code": "SV",
      "ibx_name": "SV1"
    }
  ]
}

```

52

Error Code in Response:

HTTP Status Code	Error Code	Error Description
400	40001	Invalid Parameter Value
401	40102	Token Expired, need to login again
401	40104	Invalid Access Token
401	40105	User doesn't have sufficient privilege to perform the operation
406		Not Acceptable
415		Unsupported Media Type
500		Internal Server Error

PATCH Virtual Circuit:

Description: The PATCH operation can be used to perform the following three types of operations on a virtual circuit by the seller:

- Accept a Virtual Circuit created by a buyer
- Reject a Virtual Circuit created by a buyer
- Confirm the deletion of the Virtual Circuit by a buyer

Request

Request URI(s):

PATCH <http://<HostName>/ecx/v1/virtualcircuits/{virtual circuit id}>

Request Headers:

Header Attribute	Description
Authorization	Required. Specify the Oauth Bearer token

Request Fields:

action	
Description	Action on the resource. Valid values are approve, reject, confirm_delete, available, not_available
Type	string
Required	Yes
Default	None
Example	approve
port_name	
Description	Seller side Port Name
Type	string
Required	Yes
Default	None
Example	GSE_QA-SJC-06GMR-CIS-2-SEC-A
vlan_id	
Description	Seller side VLAN Id
Type	string
Required	Yes
Default	None
Example	xxxx-xxxxxx

redundant_vlan_id

reject_comment—seller side comment to explain the rejection of the virtual circuit

Sample Request

```

PATCH http://<hostname>/ecx/vc2/virtualcircuit/4D34239266A3952695956A
{
  "action": "approve",
  "port_name": "GSE_QA-SJC-06GMR-CIS-2-SEC-A",
  "vlan_id": "188"
}
    
```

Response:

10

-continued

Response Fields:

result

		HTTP				
		Status Code	Error Code	Error Description		
result		15	400	40008	Virtual Circuit cannot be deleted by seller as it is not deleted by the buyer	
Description	Result of the Operation indication whether it was successful. Valid values are SUCCESS and ERROR		400	40009	Application specific error. Ex., duplicate VLAN Id	
Type	string		400	40010	Invalid value for grant_type. The acceptable value is "password".	
Required	Yes		20	401	40101	Authentication Failed. Invalid Username or Password.
Default	None			401	40102	Token Expired. Login again.
Example	SUCCESS			401	40103	Invalid API Key

Sample Response:

```

HTTP/1.1 200 OK
{
  "result": "SUCCESS",
  "message": "The requested virtual circuit has been rejected and the buyer has been notified.",
  "more_info": "https://api.developer.cloudexchange.com/docs/api/messages/vcs/2"
}
    
```

Error Code in Response:

35

-continued

		HTTP			
		Status Code	Error Code	Error Description	
			401	40104	Invalid Access Token
		40	401	40105	User doesn't have sufficient privilege to perform the operation
			404		Not Found
			405		Method not Allowed
			406		Not Acceptable
			415		Unsupported Media Type
			500		Internal Server Error
		45	503		Service Unavailable
			504		Gateway Timeout
			406		Invalid Access Token
			406		User doesn't have sufficient privilege to perform the operation
			406		Not Acceptable
		50	415		Unsupported Media Type
			500		Internal Server Error

All Error Codes

		HTTP			
		Status Code	Error Code	Error Description	
			400	40001	Invalid Parameter Value
			400	40002	The value of VLAN should be between 1 and 4095
			400	40003	Cannot select the same port for Primary and Secondary Service
			400	40004	Enter a value for all required fields
			400	40005	The number of characters exceeded
			400	40006	Cannot select the same name for Primary and Secondary Virtual Circuit
			400	40007	Invalid Field Value

Other endpoints **406** may have request/response schemes similar to those provided above for Login **406A**, Ports **406B**, Metros **406C**, Virtual Circuits **406E**, and Cloud Services **406F**.

Login **406A** enables a secure channel for access to inter-connection assets by authenticated and authorized partners and customers. Moreover, the interconnection platform provides out-of-the-box capability to address security issues (threat protection, SQL Injection protection, DDoS attack prevention, JSON bomb protection, etc.). In some examples, an entity uses its credentials (e.g., username, password, API key, and/or API secret) to obtain a security token (e.g., an OAuth 2.0 token) using Login **406A**, the security token thereafter ensuring that requests issued by the now-authorized entity to other endpoints **406** are from an authorized customer or partner.

API gateway **403**, in some examples, transforms application data formatted according to a request to any of endpoints **406** and uses the transformed application data to make calls to orchestration engine **407**. Orchestration engine

407 may represent one or more real servers and/or virtual machines configured to implement the cloud exchange platform services 408A-408H (collectively, “platform services 408”) in this example. In response to invocation by API gateway 403 A workflow and rules engine (not shown in FIG. 3B) of orchestration engine 407 may apply defined rules and policies to generate a workflow of cloud exchange API services 409 that, in general, fit within an overall function associated with one of platform services 408. As illustrated, the platform services 408 include policy management 408A, profiles and configuration 408B, billing and invoicing 408C, seller API integration 408D, virtual circuit management 408E, network interface management 408F, search and recommendation 408G, and inventory and location discovery 408H. Each of platform services may represent a workflow and rules engine for a different aspect of cloud service provisioning.

Cloud exchange API services 409A-409R (collectively, “cloud exchange services 409”) represent services offered by the interconnection platform to modify the cloud exchange network infrastructure, manage content, manage incidents, manage inventory and capacity, ensure secured access, and manage orders/billing for providers and customers, as examples. Any of cloud exchange services 409 may itself represent a bundle of microservices for request/response transactions invocable by orchestration engine 407 managing a workflow.

Cloud exchange services 409 includes request validation 409A, authorization and auditing 409B, account and profile management 409C, inventory management 409D, capacity management 409E, network provisioning 409F, credit check validator 409G, billing 409H, seller API integration 409I, location 409J, trouble ticket management 409K, localization 409L, usage statistics 409M, recommendation 409N, schedulers and batch processors 409O, notifications 409P, error parser 409Q, and content management 409R. Seller API integration 409I may enable orchestration engine 407 to invoke software interfaces of seller applications of CSPs to, e.g., request that the seller application confirm addition or deletion of virtual circuits (as requested by the NSP/customer) on behalf of the seller.

FIG. 4 is a block diagram showing an alternative representation of an interconnection platform 103 for a cloud exchange according to techniques described in this disclosure. In this diagram, the technical architecture for interconnection platform 103 includes an API services layer 420 for validating and satisfying API queries, validating and satisfying API commands, and integrating subsystems 120 with the interconnection orchestration engine 407. One or more real servers and/or virtual machines of a data center may execute each of interconnection orchestration engine 407, services of API services layer 420, and sub-systems 120. Interconnection API endpoints 406 are example API endpoints by which API consumers 402 (FIG. 3A) may manage cloud exchange interconnections.

Workflow management and routing component 410 manages workflows and routes API calls to endpoints 406 to engines 412A-412J (collectively, “engines 412”) that perform consolidated functionality by invoking various microservices of API services layer 420. Engines 412 include authentication and authorization engine 412A; configuration, audit, and tracking engine 412B; API command controllers 412C; API query controllers 412D; service composition engine 412E; order management engine 412F; notification engine 412G; recommendation and analytics engine 412H; interconnection interface engine 412I; and API workflow and rules repository 412J.

Examples API services of API services layer, as illustrated, include API query services 422A having request parameter validator services 424A and query provider services 424B; API command services 422B having request body validator services 424C and command provider services 424D; and integration façade services 422C having request delegator and service adapter 424E and response parsing and transformation 424F.

Examples of sub-systems 120 are illustrated in FIG. 4. Identification and access management system 426A performs authentication and authorization to valid access to the interconnection platform services. Seller API integration module 426B facilitates integration of the interconnection platform 103 with cloud service provider APIs for creating and validating interconnections with cloud service provider networks, as described elsewhere herein. Cloud exchange database 428 represents a configuration database describing the configuration of the cloud exchange managed by interconnection platform 103. Network system 426C provisions, configures, queries, and otherwise controls the network infrastructure of the cloud exchange managed by interconnection platform 103. Order management system 426D performs end-to-end management of customer orders for, e.g., virtual circuits. Incident management system 426E facilitates handling errors in the cloud exchange managed by interconnection platform, such as by alerting the cloud exchange provider, notifying customers, etc. Content management system 426F manages content for the interconnection platform 103.

FIGS. 5-11 are flow diagrams each illustrating a call flow and operations performed by example components of an interconnection platform for a cloud exchange, as described in this disclosure.

In the example of FIG. 5, API consumers 402 (e.g., a buyer/seller/third party) can make use of services 409 to manage cloud exchange interconnections. FIG. 5 illustrates a process which can be used for virtual circuit creation applicable to all Cloud Service Providers (CSPs). For example, one of API consumers 402 can pass login information, such as one or more of a user name, password, API key, and API secret, to API gateway 403 (454A). API gateway 403 performs API key and API secret validation (454B), interacts with identity management and federation 450 (454C, 454D), and provides an OAuth 2.0 token back to the API developer 402 (454E). API developer 402 receives the OAuth 2.0 token and can invoke an API endpoint (e.g., one of API endpoints 406) by providing the OAuth 2.0 token and one or more parameters to API gateway 403 (454F). API gateway 403 may perform a data format transformation (e.g., XML, JSON) (454G) and OAuth 2.0 token validation (454H). API gateway 403 then contacts orchestration engine 407 to invoke the cloud exchange platform service (456A).

Orchestration engine 407 orchestrates an API workflow based on defined rules and responses. For example, workflow and rules engine 306 of orchestration engine 407 can orchestrate the API workflow based on one or more of policies 308A, profiles 308B, configurations 308C, and micro services 308D (FIG. 2). Generally speaking, orchestration engine 407 can invoke one or more services 409 in parallel or in a defined order based on configured rules and/or policies. In the example of FIG. 5, orchestration engine 407 invokes service A (460A) and service B (460B) of services 409, then receives a response from service A (460C) and receives a response from service B (460D). Orchestration engine 407 then invokes service C (460E) and receives a response from service C (460F). Orchestration engine 407 sends to API gateway 403 a response from the

cloud exchange platform service (456B). API gateway 403 receives the response from the cloud exchange platform service, and may perform a data format transformation (e.g., XML, JSON) on the information received in the response (4541). API gateway 403 sends one or more response headers and body to API developer 402 that invoked the API endpoint (454J).

In this manner, orchestration engine 407 provides an interconnection platform for a cloud exchange, making interconnection asset information available to API consumers 402 through machine-to-machine interaction. The process outlined in FIG. 5 may be applied to different use cases, such as for allowing API consumers to obtain information about one or more virtual circuits, allowing API consumers to obtain information about one or more interconnection assets (e.g., metro-based cloud exchanges, cloud exchange points, ports of cloud exchanges), allowing sellers to define parameters for connectivity, allowing API consumers to obtain information about cloud service profile and attributes expected for creation of a virtual circuit, or near real-time deletion of virtual circuits by buyers.

FIG. 6 is a flow diagram illustrating a call flow and operations performed by example components of an interconnection platform for a cloud exchange in making interconnection asset information available to API consumers 402 through machine-to-machine interaction. FIG. 6 includes some operations similar to those described above respect to FIG. 5. In response to receiving a request from API gateway 403 invoking the cloud exchange platform service, orchestration engine 407 can orchestrate an API workflow based on defined rules and responses. For example, FIG. 6 allows API consumers 402 to obtain information such as an OAuth 2.0 token from permission data store 452 through machine-to-machine interaction. Specifically, API gateway 403 can send a user name and password received from API developer 402 (454A), after validation (454B), to identity management and federation 450 (454C), which in turn provides this information to permission data store 452 (462A), which returns a user name and user key to identity management and federation 450 (462B). Identity management and federation 450 may perform SAML to OAuth mapping (462C), and provides an OAuth token to API gateway 403 (454D). API gateway 403 can perform an OAuth Token to Gateway OAuth 2.0 mapping (462D), and may optionally perform an XML/JSON conversion (462E). API gateway 403 then provides the OAuth 2.0 token to API developer 402 (454E).

FIG. 7 is a flow diagram illustrating a call flow and operations performed by example components of an interconnection platform for a cloud exchange in making interconnection asset information available to API consumers 402 through machine-to-machine interaction. FIG. 7 includes some operations similar to those described above respect to FIG. 5. In response to receiving a request from API gateway 403 invoking the cloud exchange platform service (470E), orchestration engine 407 can orchestrate an API workflow based on defined rules and responses. For example, FIG. 7 shows how orchestration engine 407 can invoke a port request parameter validation service of services 409 specifying port parameters that were included in the initial request from API developer 402 invoking the ports endpoint (470F). Orchestration engine 407 receives a response from the port request parameter validation service indicating whether the port request parameter(s) are valid (470G). Orchestration engine 407 can then invoke a port query service (470H) and receive a response from port query service (470I), e.g., specifying specific port information

based on the port request parameters. Orchestration engine 407 can include the port information in the response from the cloud exchange platform service to API gateway 403 (470J), and API gateway 403 in turn after data transformation (470K) can provide the port information to API consumers 402 (470L).

FIG. 8 is a flow diagram illustrating a call flow and operations performed by example components of an interconnection platform for a cloud exchange in making interconnection asset information available to API consumers 402 through machine-to-machine interaction. FIG. 8 includes some operations similar to those described above respect to FIG. 5. In response to receiving a request from API gateway 403 invoking the cloud exchange platform service (472E), orchestration engine 407 can orchestrate an API workflow based on defined rules and responses. For example, FIG. 8 shows how orchestration engine 407 can invoke a metro request parameter validation service of services 409 specifying metro parameters that were included in the initial request from API developer 402 invoking the metros endpoint (472F). Orchestration engine 407 receives a response from the metro request parameter validation service, e.g., indicating whether the metro request parameter(s) are valid (472G). Orchestration engine 407 can then invoke a metro query service (472H) and receive a response from metro query service, e.g., specifying specific metro information based on the metro request parameters (472I). Orchestration engine 407 can include the metro information in the response from the cloud exchange platform service to API gateway 403 (472J), and API gateway 403 in turn after data transformation (472K) can provide the metro information to API consumers 402 (472L).

FIG. 9 is a flow diagram illustrating a call flow and operations performed by example components of an interconnection platform for a cloud exchange in making interconnection asset information available to API consumers 402 through machine-to-machine interaction. FIG. 9 includes some operations similar to those described above respect to FIG. 5. In response to receiving a request from API gateway 403 invoking the cloud exchange platform service (474E), orchestration engine 407 can orchestrate an API workflow based on defined rules and responses. For example, FIG. 9 shows how orchestration engine 407 can invoke a cloud service request parameter validation service of services 409 specifying cloud service parameters that were included in the initial request from API developer 402 invoking the cloud services endpoint (474F). Orchestration engine 407 receives a response from the cloud service request parameter validation service, e.g., indicating whether the cloud service request parameter(s) are valid (474G). Orchestration engine 407 can then invoke a cloud service query service (474H) and receive a response from cloud service query service, e.g., specifying specific cloud service information based on the cloud service request parameters (474I). Orchestration engine 407 can include the cloud service information in the response from the cloud exchange platform service to API gateway 403 (474J), and API gateway 403 in turn after data transformation (474K) can provide the cloud service information to API consumers 402 (474L).

FIG. 10 is a flow diagram illustrating a call flow and operations performed by example components of an interconnection platform for a cloud exchange in making interconnection asset information available to API consumers 402 through machine-to-machine interaction. FIG. 10 includes some operations similar to those described above respect to FIG. 5. In response to receiving a request from

API gateway 403 to view a virtual circuit and invoking the cloud exchange platform service (476E), orchestration engine 407 can orchestrate an API workflow based on defined rules and responses. For example, FIG. 10 shows how orchestration engine 407 can invoke a virtual circuit request parameter validation service of services 409 (476F) specifying virtual circuit parameters that were included in the initial request (476A) from API developer 402 invoking the virtual circuit endpoint. Orchestration engine 407 receives a response from the virtual circuit request parameter validation service, e.g., indicating whether the virtual circuit request parameter(s) are valid (476G). Orchestration engine 407 can then invoke a virtual circuit query service (476H) and receive a response from virtual circuit query service, e.g., specifying specific cloud service information based on the virtual circuit request parameters (476I). Orchestration engine 407 can include the virtual circuit information in the response (476J) from the cloud exchange platform service to API gateway 403, and API gateway 403 in turn after data transformation (476K) can provide the virtual circuit information to API consumers 402 (476L).

FIG. 11 is a flow diagram illustrating a call flow and operations performed by example components of an interconnection platform for a cloud exchange in dynamically managing interconnection assets for API consumers 402 through machine-to-machine interaction. FIG. 11 includes some operations similar to those described above respect to FIG. 5. In response to receiving a request from API gateway 403 invoking the cloud exchange platform service (480E), orchestration engine 407 can orchestrate an API workflow based on defined rules and responses. For example, FIG. 11 shows how orchestration engine 407 can invoke a metro service (480F) to validate a metro code included in the initial request from API developer 402 invoking the virtual circuit endpoint (480A). Orchestration engine 407 receives a response from the metro service (480G).

Orchestration engine 407 can then validate a cloud service provider name with a cloud service (480H), and receive a response from cloud service (480I). Orchestration engine 407 can then invoke a port service to validate the seller and buyer ports (480J), and receive a response from the port service specifying whether the ports are valid for the requested virtual circuit (480K). Orchestration engine 407 can then invoke a network service provisioning service (e.g., network provisioning service 409F, FIG. 3B) to automatically configure the virtual circuit within the cloud exchange (480L), and receive a response from the network service provisioning service (480M). Orchestration engine 407 can then invoke a billing service (e.g., billing service 409H, FIG. 3B) (480N) and receive a response from the billing service (480O). Orchestration engine 407 can then invoke a CSP API to complete virtual circuit creation (480P), and receive a response from the CSP API (480Q). Orchestration engine 407 can include the virtual circuit information describing, e.g., whether the virtual circuit creation was successful, confirmation parameters, and connectivity parameters, in the response from the cloud exchange platform service to API gateway 403 (480R), and API gateway 403 in turn after data transformation (480S) can provide the virtual circuit information to the requesting API consumers 402 (480T).

In this manner, the techniques of this disclosure can be used to make Interconnection Asset Information such as Virtual Circuits and Ports information available to developers through machine-to-machine interaction. In some examples, the techniques of this disclosure can allow access to an Interconnection platform to enable creation or modification of Virtual Circuits of varying bandwidths through

machine-to-machine interaction. In some examples, the techniques of this disclosure can allow Sellers (e.g., CSPs, NSPs and managed SP (MSPs)) the access to the Interconnection platform to obtain customized analytics about competitor presence in different metros and data centers through machine-to-machine interaction.

In some examples, the techniques of this disclosure can allow Buyers (e.g., NSPs, Enterprises) the access to the Interconnection Platform to obtain customized analytics about cloud service presence in areas where they already have port presence through machine-to-machine interaction. In some examples, the techniques of this disclosure can allow Sellers (CSPs, NSPs, and MSPs) the access to Interconnection platform to obtain customized analytics about buyer port density across different metros and data centers through machine-to-machine interaction. In some examples, the techniques of this disclosure can allow automated API request interception to validate partner access to interconnection assets, thus ensuring security of partner assets through machine-to-machine interaction. In some examples, the techniques of this disclosure can allow on demand access to dynamically set up and tear down virtual circuits through machine-to-machine interaction and direct access to interconnection platform resources. In some examples, the techniques of this disclosure can allow on demand access to schedule setup and tear down of virtual circuits at pre-defined intervals through machine-to-machine interaction and direct access to interconnection platform resources. In some examples, the techniques of this disclosure can accept and Allow request for virtual circuit speed bursting at certain pre-scheduled times to buyers (NSPs and enterprises) to capitalize on lower bandwidth usage and enable faster completion of batch processing tasks such as data backup or restore through machine-to-machine interaction (speed bursting).

In some examples, the techniques of this disclosure can allow detailed and customized analytics on virtual circuit traffic usage across data centers, metros and regions through machine-to-machine interaction. In some examples, the techniques of this disclosure can provide detailed and customized recommendations through APIs to partner developers and business teams on setting up their ports and virtual circuits for optimal performance, low latency and better interconnectivity through machine-to-machine interaction. In some examples, the techniques of this disclosure can allow machine based access to interconnection assets through the use of APIs. In some examples, the techniques of this disclosure can allow on demand setup of virtual circuits between buyers and sellers through the use of API ecosystem. In some cases, APIs may enable a much better connectivity between buyers and sellers through the availability of location discovery, asset discovery, cloud service discovery, customized traffic analytics, customized usage analytics, superior recommendation engine and an end-to-end automated virtual circuit provisioning system, for example, while abstracting the complexity of the entire interconnection platform. APIs can also enable a secure channel for access to interconnection assets outside of the cloud exchange domain by authenticated and authorized partners and customers. The API platform provides out of the box capability to address security issues (e.g., threat protection, SQL Injection protection, DDoS attack prevention, JSON bomb protection, etc.).

Example details of a cloud-based service exchange are found in U.S. Provisional Patent Application No. 62/149,

374, entitled “Cloud-based Services Exchange” and filed on Apr. 17, 2015, which is incorporated herein by reference in its entirety.

Further example details of services exchanges for Ethernet and L3/Internet with direct L3/BGP peering are found in U.S. Pat. No. 8,537,845 entitled “REAL TIME CONFIGURATION AND PROVISIONING FOR A CARRIER ETHERNET EXCHANGE”, filed Sep. 13, 2012; U.S. Utility application titled “REAL TIME CONFIGURATION AND PROVISIONING FOR A CARRIER ETHERNET EXCHANGE” filed on Sep. 2, 2010 having application Ser. No. 12/875,054, which claims the benefit of and priority to all three: 1) U.S. Provisional application titled “ETHERNET EXCHANGE” filed on Dec. 10, 2009 having application Ser. No. 61/285,371 and is incorporated herein by reference in its entirety; 2) U.S. Provisional application titled “PRIVATE NETWORK CONNECTIVITY PLATFORM” filed on Sep. 4, 2009 having application Ser. No. 61/239,997 and is incorporated herein by reference in its entirety; and 3) U.S. Provisional application titled “ETHERNET EXCHANGE” filed on Apr. 12, 2010 having application Ser. No. 61/323,066 and is incorporated herein by reference in its entirety, and U.S. patent application titled “REAL TIME CONFIGURATION AND PROVISIONING FOR A CARRIER ETHERNET EXCHANGE” filed on Sep. 2, 2010 having application Ser. No. 12/875,054. Each of the above patents and patent applications are incorporated herein by reference in their respective entireties.

FIG. 12 is a block diagram illustrating further details of one example of a computing device that operates in accordance with one or more techniques of the present disclosure. FIG. 12 may illustrate a particular example of a server or other computing device 500 that includes one or more processor(s) 502 for executing any one or more of API gateway 112/403, orchestration engine 118/407, sub-systems 120, or any other computing device described herein. Other examples of computing device 500 may be used in other instances. Although shown in FIG. 12 as a stand-alone computing device 500 for purposes of example, a computing device may be any component or system that includes one or more processors or other suitable computing environment for executing software instructions and, for example, need not necessarily include one or more elements shown in FIG. 12 (e.g., communication units 506; and in some examples components such as storage device(s) 508 may not be co-located or in the same chassis as other components). Computing device 500 may be located and execute, for example, within any of cloud exchange points 128, another interconnection facility, or at a branch office or cloud computing environment employed or used by a cloud exchange provider.

As shown in the specific example of FIG. 12, computing device 500 includes one or more processors 502, one or more input devices 504, one or more communication units 506, one or more output devices 512, one or more storage devices 508, and user interface (UI) device 510, and communication unit 506. Computing device 500, in one example, further includes one or more applications 522, virtual concept-building application 524, and operating system 516 that are executable by computing device 500. Each of components 502, 504, 506, 508, 510, and 512 are coupled (physically, communicatively, and/or operatively) for inter-component communications. In some examples, communication channels 514 may include a system bus, a network connection, an inter-process communication data structure, or any other method for communicating data. As one example, components 502, 504, 506, 508, 510, and 512 may

be coupled by one or more communication channels 514. Computing device 500 may be located and execute, for example, within any of cloud exchange points 128, another interconnection facility, or at a branch office or cloud computing environment employed or used by a cloud exchange provider.

Processors 502, in one example, are configured to implement functionality and/or process instructions for execution within computing device 500. For example, processors 502 may be capable of processing instructions stored in storage device 508. Examples of processors 502 may include, any one or more of a microprocessor, a controller, a digital signal processor (DSP), an application specific integrated circuit (ASIC), a field-programmable gate array (FPGA), or equivalent discrete or integrated logic circuitry.

One or more storage devices 508 may be configured to store information within computing device 500 during operation. Storage device 508, in some examples, is described as a computer-readable storage medium. In some examples, storage device 508 is a temporary memory, meaning that a primary purpose of storage device 508 is not long-term storage. Storage device 508, in some examples, is described as a volatile memory, meaning that storage device 508 does not maintain stored contents when the computer is turned off. Examples of volatile memories include random access memories (RAM), dynamic random access memories (DRAM), static random access memories (SRAM), and other forms of volatile memories known in the art. In some examples, storage device 508 is used to store program instructions for execution by processors 502. Storage device 508, in one example, is used by software or applications running on computing device 500 to temporarily store information during program execution.

Storage devices 508, in some examples, also include one or more computer-readable storage media. Storage devices 508 may be configured to store larger amounts of information than volatile memory. Storage devices 508 may further be configured for long-term storage of information. In some examples, storage devices 508 include non-volatile storage elements. Examples of such non-volatile storage elements include magnetic hard discs, optical discs, floppy discs, flash memories, or forms of electrically programmable memories (EPROM) or electrically erasable and programmable (EEPROM) memories.

Computing device 500, in some examples, also includes one or more communication units 506. Computing device 500, in one example, utilizes communication units 506 to communicate with external devices via one or more networks, such as one or more wired/wireless/mobile networks. Communication units 506 may include a network interface card, such as an Ethernet card, an optical transceiver, a radio frequency transceiver, or any other type of device that can send and receive information. Other examples of such network interfaces may include 3G and WiFi radios. In some examples, computing device 500 uses communication unit 506 to communicate with an external device.

Computing device 500, in one example, also includes one or more user interface devices 510. User interface devices 510, in some examples, are configured to receive input from a user through tactile, audio, or video feedback. Examples of user interface devices(s) 510 include a presence-sensitive display, a mouse, a keyboard, a voice responsive system, video camera, microphone or any other type of device for detecting a command from a user. In some examples, a presence-sensitive display includes a touch-sensitive screen.

One or more output devices 512 may also be included in computing device 500. Output device 512, in some

examples, is configured to provide output to a user using tactile, audio, or video stimuli. Output device 512, in one example, includes a presence-sensitive display, a sound card, a video graphics adapter card, or any other type of device for converting a signal into an appropriate form understandable to humans or machines. Additional examples of output device 512 include a speaker, a cathode ray tube (CRT) monitor, a liquid crystal display (LCD), or any other type of device that can generate intelligible output to a user.

Computing device 500 may include operating system 516. Operating system 516, in some examples, controls the operation of components of computing device 500. For example, operating system 516, in one example, facilitates the communication of one or more applications 522 and interconnection platform application(s) 524 with processors 502, communication unit 506, storage device 508, input device 504, user interface devices 510, and output device 512.

Application 522 and interconnection platform application(s) 524 may also include program instructions and/or data that are executable by computing device 500. Example interconnection platform application(s) 524 executable by computing device 500 may include any one or more of orchestration engine module 550, API gateway module 552, and sub-systems 554, each illustrated with dashed lines to indicate that these may or may not be executable by any given example of computing device 500.

Orchestration engine module 550 may include instructions for causing computing device to perform one or more of the operations and actions described in the present disclosure with respect to orchestration engine 118 and orchestration engine 407. As one example, orchestration engine module 550 may include instructions that cause computing device 500 to organize, direct and integrate underlying software sub-systems of the interconnection platform for a cloud exchange for managing various aspects of interconnection within the network infrastructure as well as cloud services management. The orchestration engine module 550 may, for example, provide a rule-driven workflow engine that operates between the APIs and the underlying interconnect platform of a cloud exchange that includes sub-systems and network infrastructure.

API gateway module 552 may include instructions for causing computing device to perform one or more of the operations and actions described in the present disclosure with respect to API gateway 112 and API gateway 403. As one example, API gateway module 403 may include instructions that cause computing device 500 to expose a collection of software interfaces, e.g., APIs 114, that define the methods, fields, and/or other software primitives by which applications may invoke the interconnection platform. These software interfaces allow carriers and customers programmatic access to capabilities and assets of a cloud exchange.

Sub-systems 554 may include instructions for causing computing device to perform one or more of the operations and actions described in the present disclosure with respect to sub-systems 120.

FIG. 13 is a block diagram illustrating an example cloud exchange system 700 showing an example logical architecture of an orchestration engine 704 in further detail. Orchestration engine 704 may represent, for example, any of orchestration engine 118 (FIGS. 1A-1C and FIG. 2), orchestration engine 407 (FIGS. 3A-3B, 4-5, 7-11), and orchestration engine module 550 of computing device 500 (FIG. 12).

The orchestration engine 704 operates as part of an overall interconnection platform (e.g., interconnection plat-

form 103 of FIGS. 1B, 1C) to seamlessly set up interconnection assets including virtual connections (e.g., virtual circuits) between buyers and sellers, such as between an enterprise and a cloud service provider. In the example of FIG. 13, orchestration engine 704 includes two major components: orchestrator 706 and microservices 708 provided by the cloud exchange system 700. Orchestration engine 704 also includes service discovery engine 710 and process manager 712. Orchestration engine 704 may represent a centralized or distributed application and may execute on a management device such as one or virtual machines and/or real servers of data center 101 (FIG. 1A).

Microservices 708 each implements a set of focused and distinct features or functions, and a microservice conforms to (or is usable in) an architectural pattern in which many dozens or even hundreds of microservices can be independently developed and deployed. Microservice 708 may be organized around a business capability (e.g., API dock engine 726, REST interfaces 728, socket connection 730, monitoring 732, and notifications 734) and may implement a “broad-stack” of software for the business capability, including persistent storage and any external collaboration. The various microservices 708 expose interfaces that enable the microservices 708 to invoke one another to exchange data and perform the respective sets of functions in order to create an overall application. In some examples, microservices 708 may represent or include other microservice examples described in this disclosure, e.g., microservices for implementing cloud exchange services 409, API query services 422A, API command services 422B, integration façade services 422C, any microservices provided by sub-systems 120, and microservices 308D.

Each of microservices 708 may adhere to a well-defined Application Programming Interface (API) and may be orchestrated, by invoking the API of the microservice 708, according to a workflow performed by the orchestrator 706. The orchestrator 706 component “orchestrates” the microservices 706 based on rules or workflow defined for various APIs exposed by the orchestrator 706 (e.g., via an API server/gateway such as API gateways 112, 403, and 718) and invocable by API requests that conform to the respective API contracts. The orchestrator 706 may handle API requests generically by following an established set of rules, or workflows, that allow a fully-customizable API contract for each external channel to API consumers, whether a portal, mobile application, or developer API, for instance. The workflow may be implemented in some examples as a state machine. Because of variability in the request/response contract for each channel, the orchestrator 706 described in this disclosure may embrace and provide equal support for the differences across different channels.

Orchestration engine 704 organizes, directs and integrates underlying software and network sub-systems for managing various aspects of interconnection for the cloud exchange. Orchestrator 706 of orchestration engine 704 may, for example, execute a rule-driven workflow engine that operates between the APIs and the underlying interconnect platform of the exchange. For example, orchestrator 706 may correspond to workflow and rules engine 306 of FIG. 2 that operates in accordance with policies 308A. In this way, orchestration engine 704 can be used by customer-proprietary applications and the APIs for direct participation within the interconnection platform of the cloud exchange.

As described herein, orchestration engine 704 synthesizes the information and actions from underlying sub-systems of the interconnection platform to formulate intelligent next steps and responses to dynamic requests made by the

customer applications. As such, orchestration engine **704** abstracts the complexity of the underlying software and network sub-systems of the cloud exchange by providing a uniform, simplified, and secured means to access the interconnection platform.

In the example of FIG. **13**, cloud exchange system **700** provides multiple platforms allowing access to the cloud exchange functionality provided by cloud exchange system **700**, including web proxy **714**, SaaS web portal **716**, and API gateway **718**. Orchestration engine **704** services all requests coming in from these platforms, regardless of whether the requests were made via cloud exchange portal **713**, white label portal **715** developed by the cloud exchange provider but labeled for the customer, and APIs **717**. For example, web proxy **714**, SaaS web portal **716**, and Web proxy **714**, SaaS web portal **716**, and API gateway **718** represent different channels for requests to access the orchestrator **706**. For example, a customer may use a web application to log in to the portal **713** and access services of the interconnection platform. As another example, a customer or developer may use APIs to access cloud exchange data. Orchestration engine **704** can receive requests entered using a cloud exchange portal **713** via web proxy **714**. Orchestration engine **704** can receive requests entered using a white label portal **715** via a SaaS web portal **716**. Orchestration engine **704** may communicate with SaaS web portal **716** (e.g., a CSP portal) using a network protocol such as Hyper Text Transfer Protocol (HTTP), for example, or other network protocol. Orchestration engine **704** can receive requests entered using APIs **717** via an API gateway **718**. API gateway **718** may represent any of the API gateways described herein and uses service discovery engine **710** to identify service instances to which to route requests received via APIs **717**.

As described briefly above, microservices **708** represent cloud exchange functions that are broken down into smaller services (microservices) organized around business capability. The microservices **708** may execute a broad-stack software implementation for that business area, including persistent storage, and any external collaboration, such as with third party systems **724**.

Orchestrator **706** receives a request from the web proxy **714**, portal **716**, or API gateway **718**, and seamlessly coordinates multiple microservices of microservices **708** to service the request. For example, based on the received request, orchestrator **706** may determine a workflow that automatically calls the microservices needed to service the request. For example, API gateway **718** passes an input, orchestration engine **704** processes the input, calls multiple microservices **708** and obtains data needed to satisfy the contracts needed by the API and sends a response to the API including the data needed by the API. For example, to create a virtual circuit, orchestrator **706** needs multiple microservice endpoints. For example, orchestrator **706** needs a metro, a port, and billing information. These are all individual internal APIs which are seamlessly orchestrated through orchestrator **706**, as described herein. With a request/response operation, the API (for instance) may invoke the metro microservice, and the orchestration engine invokes a managed metro routine (workflow) and performs required services to fulfill the request with regard to that metro routine, via the microservice, and then sends back any data relevant to the operation. Orchestration engine **704** may invoke cloud service provider connectors from one of the microservices. In this manner, orchestration engine **704** provides the service or data requested by the customer in a seamless manner such that the customer is not made aware of the underlying details

of the individual microservices being invoked according to the workflow selected by the orchestrator **706** for servicing the customer request.

In some examples, the microservices **708** may represent microservices developed and provided by cloud service providers. That is, orchestrator **706** may invoke a cloud service provider interface accessible via one of the microservices. For example, Azure (provided by Microsoft Corporation) may provide cloud services and expose an interface accessible by one of the microservices **708** developed for the purpose of managing the cloud services. The orchestrator **706** can call a RESTful interface (an example of a "CSP API" described elsewhere herein) to the microservice provided by Azure to fulfill some of the functionality. For example, to create a virtual connection from the cloud-exchange application to a cloud service provider, the orchestration engine **704** may invoke an Azure-provided microservice to perform certain of the functions, such as enabling a port. After invoking the Azure-provided microservice, the orchestrator may invoke other microservices to implement the overall workflow. For example, the orchestrator may then invoke ordering, validation, and/or authentication microservices. RESTful API endpoints/channels may provide accessibility to microservices.

In the example of FIG. **13**, microservices **708** include an internal API document engine API **726** ("API Doc Engine"), REST interface microservice **728**, socket connection microservice **730**, monitoring microservice **732**, notifications microservice **734**, and API service framework **722**. Orchestration engine **704** also uses internal API service framework **722** to interact with various internal or third party systems via APIs, when invoking one or more of microservices **708**. Microservices **708** may present API interfaces to orchestrator **706** and execute in the API service framework **722**. APIs **721A-721C** ("APIs **721**") may be called by components of a microservices layer of orchestration engine **704**, and may be considered microservice endpoints. APIs **721** are not customer-facing APIs.

In the example of FIG. **13**, orchestration engine **704** uses API service framework **722** to interact with enterprise systems **720** via private API **721A**. Orchestration engine **704** uses API service framework **722** to interact with other systems **723** via private API **721B**. Orchestration engine **704** uses API service framework **722** to interact with third party systems via a public API **721C**, and to integrate cloud-based services platforms into the cloud exchange.

FIG. **14** is a block diagram illustrating an example system **800** showing a reference architecture for an orchestration engine **704** in further detail. Orchestration engine **704** may represent, for example, any of orchestration engine **118** (FIGS. **1A-1C** and FIG. **2**), orchestration engine **407** (FIGS. **3A-3B**, **4-5**, **7-11**), orchestration engine module **550** of computing device **500** (FIG. **12**), and orchestration engine **704** of FIG. **13**. As one example, system **800** may represent a different logical view of cloud exchange system **700** of FIG. **13**.

Orchestration engine **704** operates as part of an overall interconnection platform (e.g., interconnection platform **103** of FIGS. **1B**, **1C**) to seamlessly set up interconnection assets including virtual connections (e.g., virtual circuits) between buyers and sellers, such as between an enterprise **840** and a cloud service provider **842**. For example, orchestration engine **704** may seamlessly set up virtual circuits **150**, **155**, **160**, **165**, **170** between customer systems **196** of FIG. **1C**.

Orchestration engine **704** may be represented centralized or distributed applications and may execute on a management device such as one or virtual machines and/or real servers of

data center 101 (FIG. 1A). Orchestration engine 704 may receive requests for interconnection assets from various customer systems. For example, orchestration engine 704 may receive requests from internal administrators (i.e., administrators belonging to the same entity as orchestration engine 704) (“admin”), network service providers (NSP), cloud service providers (CSP) 842, enterprises 840 and developers. Orchestration engine 804 may receive the requests at web proxy 810 via browser 812A, at white label SaaS 814 via browser 812B, or at API gateway 816 via API 818.

Orchestrator 806 can manage workflows for performing such functions as manage port, manage metro, CSP detail, order management, view virtual circuit, delete virtual circuit, search, support and tickets, monitoring and statistics, analytics and recommendation, for example. Orchestrator 806 can also perform additional functions not shown, including those described above with respect to orchestration engine 407. In some examples, orchestrator 806 may maintain a library of workflows, from which orchestrator can select and load a suitable workflow in response to receiving a request via any of the channels mentioned above.

In some examples, orchestration engine 704 may run as a set of virtual machines executing on a server network device. Orchestration engine 704 may be built and run on a software application platform such as Node.js. Microservices may be enabled using a web application framework. Microservices and workflows may be built and run as distributed applications in software containers. Orchestration engine 704 may use in-memory grid caching using an in-memory and persistent disk database.

Aspects of the orchestration engine 704 may be built on Node.js or other similar platform that, e.g., provides an event-driven architecture and a non-blocking I/O API designed to optimize an application’s throughput and scalability for real-time web applications. Node.js is a lightweight, open-source platform having that facilitates loosely-coupled and scalable systems that communicate using, e.g., HTTP and JSON, which are built into Node.js. This may facilitate microservice design principles for creating and deploying microservices 708.

The orchestrator 706 may use state machines to implement workflows that invoke multiple microservices 706 in a defined ordering to satisfy an API contract. Microservices 706 (and multiple instances of each of microservices 706) may be deployed in separate containers for isolation and modularity, while also providing enhanced quality and reliability with integrated testing, logging, monitoring, and diagnostic strategies. Container technology is a mechanism for deploying units of work across a vast pool of compute resources and has become a strategic deployment strategy for scalability. Microservices and containers provide a convergence of technical approaches to building scalable systems. Node.js is an open source platform that is optimized for building highly scalable lightweight, asynchronous communicating processes and exposing APIs to any Web consumer. Orchestration engine 704 may leverage Node.js, microservices, and containers, for implementation and deployment as a microservices-based interconnection platform for a cloud-based services exchange.

Orchestration engine 704 also includes functionality for calling utility functions 819 including error framework, logging, administration, notifications, auditing, and monitoring, for example. Utility functions 819 may include a process manager to keep applications alive with zero downtime, and which performs process monitoring, process log watching, memory management, and the like.

FIG. 14 also illustrates a plurality of internal microservices 708 of orchestration engine 704 including, for example, virtual circuit, port, link aggregation group (LAG), metro, CSP detail, Quality of Service (QoS), customer service and ticketing, search (e.g., CSP, NSP, locations, ports, virtual circuits), assets and network inventory, language, and service settings. Microservices 708 present individual internal APIs (that is, internal to orchestration engine 706 and not exposed via API 818, e.g.) or microservice endpoints. In some examples, microservices 708 may correspond to microservices 308D of FIG. 2. For example, the “metro” internal API of microservices 708 corresponds to a microservice interface for a metro operation that is internal to orchestration engine 704. An API consumer such as one of API consumers 402 (FIG. 3A) may request a metro via customer-facing metros API 406C of APIS 114 (FIG. 3A), and orchestrator 706 will translate from the customer-facing metros API 406C to the internal metro microservice 806. Orchestrator 706 can select a workflow that ties together the individual microservices that are needed to satisfy the customer-facing metro API operation.

Orchestration engine 704 also includes functionality for calling asynchronous jobs 817 including manual provisioning/de-provisioning, order scheduler, order status updater, usage statistics, cloud service provider location discovery, for example. The orchestrator 706 may call these jobs asynchronously.

Orchestration engine 704 can interface with various sub-systems 820A-820F (“sub-systems 820”), such as content management system 820A, traffic management systems 820B, incidence management system 820C, port management system 820D, ID and access management system 820E, and order management system 820F, for example. Sub-systems 820 may correspond to sub-systems 120 of FIGS. 1B, 1C, 2, and 4, for example. For example, content management system 820A includes data associated with content that may be distributed via a web application portal, such as SaaS web portal 716. For example, traffic management systems 820B provides traffic-related data for internal cloud exchange platform traffic, such as at the port level or virtual circuit level. In one example, when orchestrator 706 selects a workflow to provide a function relating to support and tickets, orchestrator 706 uses one of microservices 708 (e.g., customer service and ticketing microservice) to interface with one of sub-systems 820, such as incidence management system 820C, according to the selected workflow. The microservice may connect to a database, connect using a REST API, connect using a JSON call, or other mechanism, to interface with the sub-systems 820.

In some examples, sub-systems 820 may apply the service tasks orchestrated by orchestration engine 118, which may include modifying any of cloud exchange points 128 to perform the on-demand setup of virtual circuits between CSPs 842 and enterprises 840, for example, or otherwise manage cloud exchange interconnection assets such as ports, metros, data centers, virtual circuits and virtual circuit bandwidth, profiles, and configuration.

Orchestration engine 704 can interface with one or more SDN controllers 832 for the network infrastructure of the cloud-based services exchange. SDN controllers 832 may reside within the cloud exchange platform data center, such as data center 101 of FIG. 1. SDN controllers 832 may be used to connect switches between point A to point B within a cloud exchange network infrastructure. Techniques for orchestrating SDN controllers in the context of a cloud-based services exchange are described in further detail in U.S. Provisional Patent Appln. No. 62/164,965, filed May

21, 2015 and entitled “Active Panel Demarcation”; and in U.S. Provisional Patent Appln. No. 62/216,804, filed Sep. 10, 2015 and entitled “Automated Fiber Cross-connect Service within a Multi-tenant Interconnection Facility;” each of which is incorporated by reference herein in its entirety.

FIG. 15 is a flowchart illustrating an example workflow performed by an orchestration engine in accordance with example aspects of this disclosure. For purposes of example, FIG. 15 is described with respect to orchestration engine 704 of FIGS. 13 and 14, but may likewise apply to other examples of an orchestration engine described herein.

Orchestration engine 704 receives client requests for cloud exchange platform services, such as via the cloud exchange portal 814 or API gateway 816 (1500). Orchestration engine 704 sends the client request for cloud exchange platform services to orchestrator 706 (1502). Based on the client request, orchestrator 706 selects a workflow from a workflow library or folder (e.g., workflows folder 1612 of FIG. 16 including workflows WF1, WF2, WF3, and WF4), where the selected workflow contains the set of tasks needed to fulfill the request through microservice calls (1504). For example, orchestrator 706 may select the workflow based on configured rules or policies (e.g., policies 308A of FIG. 2), and/or based on a profile associated with the client (e.g., profiles 308B of FIG. 2). Orchestrator 706 will automatically load the selected workflow, and the microservices execute according to the workflow (e.g., sequentially and/or in parallel) (1506). The workflows folder 1612 contains workflows that have been previously defined (e.g., by cloud exchange developers) for each customer endpoint. For example, there may be a first workflow defined for a metro customer endpoint and a second workflow defined for a port customer endpoint. Workflows provide a set of logic that uses one or more state machines as a guide to indicate how to transfer from one state to another to fulfill the request. A workflow defines a task orchestration. Workflows provide a way to decompose a series of complex operations down to a sequence of discrete tasks within a state machine and executed by microservices to satisfy requests received via different request channels like portals and API. Each request can have different associated domain contracts. For a given request, orchestrator 706 selects a workflow that uses a sequence of discrete tasks within a state machine to satisfy the domain contract associated with the request.

The microservices then return respective responses to orchestrator 706 (1508). The responses may include data provided by the microservice. Orchestrator 706 consolidates the data received in the responses from each of the workflows, as necessary to fulfill the client request (1510). Orchestration engine 704 then responds to the client request for cloud exchange services (1512).

In this context, microservices are endpoints, and a task is an action currently executing to fulfill a request. One example task could be to call a set of microservices (endpoints), collectively. When you call a particular endpoint, some data is returned, which may be data to be used by the next endpoint, in a chain. In this manner, the workflow may define a chain of tasks to be completed, where data obtained in one task may be used in and/or may determine the next task.

As one example, a cloud exchange customer may want to connect to multiple different cloud service providers via the cloud exchange platform. In this situation, orchestrator 706 has to call multiple APIs. In another example, a cloud service provider can create a template for onboarding new

customers and provide the template to orchestrator, and the orchestrator can easily use the template for onboarding new customers who want to connect with the cloud service provider. Orchestrator 706 can orchestrate any type of workflows, and more than one customer can use the workflows. The same workflow can be used by different customers for executing the functionality they need (e.g., creating a virtual circuit). Various example workflows are illustrated and described with respect to FIGS. 5-11 and 16-17.

FIG. 16 is an example logical diagram illustrating an example orchestration engine workflow relating to creating a virtual circuit. In this example, orchestrator 706 receives a client request 1622 that invokes a “/virtual circuit” API endpoint, exposed by orchestrator 706, to provision a virtual circuit in the cloud-based services exchange between the client and a cloud service provider. Orchestrator 706 selects a workflow for provisioning a virtual circuit from workflows folder 1612, loads the selected workflow, and pushes a new job to data structure store 1610. Orchestrator 706 also subscribes to publish-subscribe server 1620 for job status.

The workflow specifies a set of task. For example, the workflow for provisioning the virtual circuit specifies a set of tasks comprising: (i) obtaining port details, (ii) obtaining metro details, and (iii) creating the virtual circuit based on the port details and the metro details. Orchestrator 706 can distribute tasks of the set of tasks across a plurality of workflow runners 1616A-1616D, which access one or more of microservices 1630A-1630D (endpoints) to perform the tasks. The workflow runners 1616 may pick jobs from a queue maintained by data structure store 1610. In some examples, each task in a selected workflow may be executed on a different thread. Tasks may be executed in parallel or sequentially. As each task finishes, publish-subscribe server 1620 is updated, and publish-subscribe server 1620 notifies orchestrator 706. For example, “Job Finished” is a method that is called once the execution of the workflow finishes. When orchestrator 706 determines that the virtual circuit has been established, orchestrator 706 may notify the client that made the request, e.g., by returning an HTTP response.

In some cases, the sequence of tasks in a workflow may be more complex than just tasks performed in a series. Tasks can fail, and so orchestrator 706 may at times need to deal with timeouts, retries, “stuck” flows, and so forth. One way to define a workflow and its tasks is using an arbitrarily-complex language. Another way may involve making some assumptions, such as: (1) Code is the definition language; (2) Tasks are independent, and can be used into different workflows; (3) The only way to communicate between tasks is the workflow. Tasks can add, remove or modify properties of the workflow. (4) If a task requires a specific property of the workflow to be present, the task can fail, or re-schedule itself within the workflow. The system must be designed with failures in mind. Tasks can fail and, as a consequence, workflows may fail. Orchestrator 706 may need to recover from a task failure, or from a whole workflow failure. In some examples, orchestrator 706 uses a service discovery engine 710 (FIG. 13) to discover an alternate microservice to use when a first task fails due to the microservice not responding properly or returning an error message.

For example, if there are five microservice tasks that orchestrator 706 has to execute for providing a cloud exchange service, process manager 712 of orchestration engine 704 can decide to execute the tasks in parallel, or sequentially. If orchestrator 706 determines that a particular microservice is not responding properly, or the microservice returns an error message, orchestrator 706 determines whether to execute the microservice again or whether there

is any other fallback microservice that orchestrator **706** can use instead. Orchestrator **708** uses service discovery engine **710** (FIG. **13**) to discover an alternate microservice (e.g., having a different uniform resource locator (URL)).

Orchestrator **706** may call a first URL for a microservice, but that microservice returns an error code. Orchestrator **706** uses service discovery engine **710** to determine whether orchestrator **706** should discover an alternate microservice (e.g., having a different uniform resource locator (URL)). For example, orchestrator **706** may invoke a port microservice, which includes multiple different URLs that are interfaces to different port applications that perform the port microservice.

FIG. **17** is an example logical diagram illustrating an example orchestration engine workflow relating to obtaining employee payroll information. In this example, orchestrator **706** receives a client request **1642** that invokes an “/employee payroll” API endpoint, exposed by orchestrator **706**, to obtain employee payroll information. Orchestrator **706** selects a workflow for obtaining employee payroll information from workflows folder **1612**, loads the selected workflow, and pushes a new job to data structure store **1610**. Orchestrator **706** also subscribes to publish-subscribe server **1620** for job status.

The workflow specifies a set of task. For example, the workflow for obtaining employee payroll information specifies a set of tasks comprising: (i) obtaining user details, (ii) obtaining user payroll details based on the user details. Orchestrator **706** can distribute tasks of the set of tasks across a plurality of workflow runners **1616A-1616D**, which access one or more of microservices **1650A-1650D** (end-points) to perform the tasks. The microservices **1650A-1650D** accessed by workflow runners **1616A-1616D** in the example of FIG. **17** may be different microservices than microservices **1630A-1630D** in the example of FIG. **16**. The workflow runners **1616** may pick jobs from a queue maintained by data structure store **1610**. In some examples, each task in a selected workflow may be executed on a different thread. Tasks may be executed in parallel or sequentially. As each task finishes, publish-subscribe server **1620** is updated, and publish-subscribe server **1620** notifies orchestrator **706**. For example, “Job Finished” is a method that is called once the execution of the workflow finishes. When orchestrator **706** determines that the employee payroll information has been obtained, orchestrator **706** may notify the client that made the request, e.g., by returning an HTTP response.

FIGS. **18A-18B** are block diagrams illustrating example network infrastructure and service provisioning by an inter-connection platform for a cloud exchange that aggregates the cloud services of multiple cloud service providers for provisioning to customers of the cloud exchange provider and aggregates access for multiple customers to one or more cloud service providers, in accordance with techniques described in this disclosure. In this example, customer networks **1808A-1808C** (collectively, “customer networks **1808**”), each associated with a different customer, access a cloud exchange point within a data center **1800** in order to receive aggregated cloud services from one or more cloud service provider networks **1820**, each associated with a different cloud service provider **110**. Customer networks **1808** each include endpoint devices that consume cloud services provided by cloud service provider network **1820**. Example endpoint devices include servers, smart phones, television set-top boxes, workstations, laptop/tablet computers, video gaming systems, teleconferencing systems, media players, and so forth.

Customer networks **1808A-1808B** include respective provider edge/autonomous system border routers (PE/ASBRs) **1810A-1810B**. Each of PE/ASBRs **1810A**, **1810B** may execute exterior gateway routing protocols to peer with one of PE routers **1802A-1802B** (“PE routers **1802**” or more simply “PEs **1802**”) over one of access links **1816A-1816B** (collectively, “access links **1816**”). In the illustrated examples, each of access links **1816** represents a transit link between an edge router of a customer network **1808** and an edge router (or autonomous system border router) of cloud exchange point **1803**. For example, PE **1810A** and PE **1802A** may directly peer via an exterior gateway protocol, e.g., exterior BGP, to exchange L3 routes over access link **1816A** and to exchange L3 data traffic between customer network **1808A** and cloud service provider networks **1820**. Access links **1816** may in some cases represent and alternatively be referred to as attachment circuits for IP-VPNs configured in IP/MPLS fabric **1801**, as described in further detail below. Access links **1816** may each include a direct physical connection between at least one port of a customer network **1808** and at least one port of cloud exchange point **1803**, with no intervening transit network. Access links **1816** may operate over a VLAN or a stacked VLAN (e.g., QinQ), a VxLAN, an LSP, a GRE tunnel, or other type of tunnel.

While illustrated and primarily described with respect to L3 connectivity, PE routers **1802** may additionally offer, via access links **1816**, L2 connectivity between customer networks **1808** and cloud service provider networks **1820**. For example, a port of PE router **1802A** may be configured with an L2 sub-interface that provides, to customer network **1808A**, L2 connectivity to cloud service provider **1820A** via access link **1816A**. The port of PE router **1802A** may be additionally configured with an L3 interface that provides, to customer network **1808A**, L3 connectivity to cloud service provider **1820B** via access links **1816A**.

Each of access links **1816** and aggregation links **1822** may include a network interface device (NID) that connects customer network **1808** or cloud service provider **1828** to a network link between the NID and one of PE routers **1802**, **1804**. Each of access links **1816** and aggregation links **1822** may represent or include any of a number of different types of links that provide L3/network connectivity.

In this example, customer network **1808C** is not an autonomous system having an autonomous system number. Customer network **1808C** may represent an enterprise, network service provider, or other customer network that is within the routing footprint of the cloud exchange point. Customer network includes a customer edge (CE) device **1811** that may execute exterior gateway routing protocols to peer with PE router **1802B** over access link **1816C**. In various examples, any of PEs **1810A-1810B** may alternatively be or otherwise represent CE devices.

Access links **1816** include physical links. PE/ASBRs **1810A-1810B**, CE device **1811**, and PE routers **1802A-1802B** exchange L2/L3 packets via access links **1816**. In this respect, access links **1816** constitute transport links for cloud access via cloud exchange point **1803**. Cloud exchange point **1803** may represent an example of any of cloud exchange points **128**. Data center **1800** may represent an example of data center **201**.

Cloud exchange point **1803**, in some examples, aggregates customers **1808** access to the cloud exchange point **1803** and thence to any one or more cloud service providers **1820**. FIGS. **18A-18B**, e.g., illustrate access links **1816A-1816B** connecting respective customer networks **1808A-1808B** to PE router **1802A** of cloud exchange point **1803** and access link **1816C** connecting customer network **1808C** to

PE router **1802B**. Any one or more of PE routers **1802**, **1804** may comprise ASBRs. PE routers **1802**, **1804** and IP/MPLS fabric **1801** may be configured according to techniques described herein to interconnect any of access links **1816** to any of cloud aggregation links **1822**. As a result, cloud service provider network **1820A**, e.g., needs only to have configured a single cloud aggregate link (here, access link **1822A**) in order to provide services to multiple customer networks **1808**. That is, the cloud service provider operating cloud service provider network **1802A** does not need to provision and configure separate service links from cloud service provider network **1802A** to each of PE routers **1810**, **1811**, for instance, in order to provide services to each of customer network **1808**. Cloud exchange point **1803** may instead cross-connect cloud aggregation link **1822A** and PE **1812A** of cloud service provider network **1820A** to multiple cloud access links **1816** to provide layer 3 peering and network reachability for the cloud services delivery.

In addition, a single customer network, e.g., customer network **1808A**, need only to have configured a single cloud access link (here, access link **1816A**) to the cloud exchange point **1803** within data center **1800** in order to obtain services from multiple cloud service provider networks **1820** offering cloud services via the cloud exchange point **1803**. That is, the customer or network service provider operating customer network **1808A** does not need to provision and configure separate service links connecting customer network **1808A** to different PE routers **1812**, for instance, in order to obtain services from multiple cloud service provider networks **1820**. Cloud exchange point **1803** may instead cross-connect cloud access link **1816A** (again, as one example) to multiple cloud aggregate links **1822** to provide layer 3 peering and network reachability for the cloud services delivery to customer network **1808A**.

Cloud service provider networks **1820** each includes servers configured to provide one or more cloud services to users. These services may be categorized according to service types, which may include for examples, applications/software, platforms, infrastructure, virtualization, and servers and data storage. Example cloud services may include content/media delivery, cloud-based storage, cloud computing, online gaming, IT services, etc.

Cloud service provider networks **1820** include PE routers **1812A-1812D** that each executes an exterior gateway routing protocol, e.g., eBGP, to exchange routes with PE routers **1804A-1804B** (collectively, "PE routers **1804**") of cloud exchange point **1803**. Each of cloud service provider networks **1820** may represent a public, private, or hybrid cloud. Each of cloud service provider networks **1820** may have an assigned autonomous system number or be part of the autonomous system footprint of cloud exchange point **1803**.

In the illustrated example, an Internet Protocol/Multiprotocol label switching (IP/MPLS) fabric **1801** interconnects PEs **1802** and PEs **1804**. IP/MPLS fabric **1801** include one or more switching and routing devices, including PEs **1802**, **1804**, that provide IP/MPLS switching and routing of IP packets to form an IP backbone. In some example, IP/MPLS fabric **1801** may implement one or more different tunneling protocols (i.e., other than MPLS) to route traffic among PE routers and/or associate the traffic with different IP-VPNs. In accordance with techniques described herein, IP/MPLS fabric **1801** implement IP virtual private networks (IP-VPNs) to connect any of customers **1808** with multiple cloud service provider networks **1820** to provide a data center-based 'transport' and layer 3 cross-connect. Whereas service provider-based IP backbone networks require wide-area network (WAN) connections with limited bandwidth to trans-

port service traffic from layer 3 services providers to customers, the cloud exchange point **1803** as described herein 'transports' service traffic and cross-connects cloud service providers **1820** to customers **1808** within the high-bandwidth local environment of data center **1800** provided by a data center-based IP/MPLS fabric **1801**. In some examples, IP/MPLS fabric **1801** implements IP-VPNs using techniques described in Rosen & Rekhter, "BGP/MPLS IP Virtual Private Networks (VPNs)," Request for Comments **4364**, February 2006, Internet Engineering Task Force (IETF) Network Working Group, the entire contents of which is incorporated by reference herein. In some example configurations, a customer network **1808** and cloud service provider network **1820** may connect via respective links to the same PE router of IP/MPLS fabric **1801**.

Access links **1816** and aggregation links **1822** may include attachment circuits that associate traffic, exchanged with the connected customer network **1808** or cloud service provider network **1820**, with virtual routing and forwarding instances (VRFs) configured in PEs **1802**, **1804** and corresponding to IP-VPNs operating over IP/MPLS fabric **1801**. For example, PE **1802A** may exchange IP packets with PE **1810A** on a bidirectional label-switched path (LSP) operating over access link **1816A**, the LSP being an attachment circuit for a VRF configured in PE **1802A**. As another example, PE **1804A** may exchange IP packets with PE **1812A** on a bidirectional label-switched path (LSP) operating over access link **1822A**, the LSP being an attachment circuit for a VRF configured in PE **1804A**. Each VRF may include or represent a different routing and forwarding table with distinct routes.

PE routers **1802**, **1804** of IP/MPLS fabric **1801** may be configured in respective hub-and-spoke arrangements for cloud services, with PEs **1804** implementing cloud service hubs and PEs **1802** being configured as spokes of the hubs (for various hub-and-spoke instances/arrangements). A hub-and-spoke arrangement ensures that service traffic is enabled to flow between a hub PE and any of the spoke PEs, but not directly between different spoke PEs. As described further below, in a hub-and-spoke arrangement for data center-based IP/MPLS fabric **1801** and for southbound service traffic (i.e., from a CSP to a customer) PEs **1802** advertise routes, received from PEs **1810**, to PEs **1804**, which advertise the routes to PEs **1812**. For northbound service traffic (i.e., from a customer to a CSP), PEs **1804** advertise routes, received from PEs **1812**, to PEs **1802**, which advertise the routes to PEs **1810**.

For some customers of cloud exchange point **1803**, the cloud exchange point **1803** provider may configure a full mesh arrangement whereby a set of PEs **1802**, **1804** each couple to a different customer site network for the customer. In such cases, the IP/MPLS fabric **1801** implements a layer 3 VPN (L3VPN) for cage-to-cage or redundancy traffic (also known as east-west or horizontal traffic). The L3VPN may effectuate a closed user group whereby each customer site network can send traffic to one another but cannot send or receive traffic outside of the L3VPN.

PE routers may couple to one another according to a peer model without use of overlay networks. That is, PEs **1810** and PEs **1812** may not peer directly with one another to exchange routes, but rather indirectly exchange routes via IP/MPLS fabric **1801**. In the example of FIG. **18B**, cloud exchange point **1803** is configured to implement multiple layer 3 virtual circuits **1830A-1830C** (collectively, "virtual circuits **1830**") to interconnect customer network **1808** and cloud service provider networks **1822** with end-to-end IP paths. Each of cloud service providers **1820** and customers

1808 may be an endpoint for multiple virtual circuits **1830**, with multiple virtual circuits **1830** traversing one or more attachment circuits between a PE/PE or PE/CE pair for the IP/MPLS fabric **1801** and the CSP/customer. A virtual circuit **1830** represents a layer 3 path through IP/MPLS fabric **1801** between an attachment circuit connecting a customer network to the fabric **1801** and an attachment circuit connecting a cloud service provider network to the fabric **1801**. Each virtual circuit **1830** may include at least one tunnel (e.g., an LSP and/or Generic Route Encapsulation (GRE) tunnel) having endpoints at PEs **1802**, **1804**. PEs **1802**, **1804** may establish a full mesh of tunnels interconnecting one another.

Each virtual circuit **1830** may include a different hub-and-spoke network configured in IP/MPLS network **1801** having PE routers **1802**, **1804** exchanging routes using a full or partial mesh of border gateway protocol peering sessions, in this example a full mesh of Multiprotocol Interior Border Gateway Protocol (MP-iBGP) peering sessions. MP-iBGP or simply MP-BGP is an example of a protocol by which routers exchange labeled routes to implement MPLS-based VPNs. However, PEs **1802**, **1804** may exchange routes to implement IP-VPNs using other techniques and/or protocols.

In the example of virtual circuit **1830A**, PE router **1812A** of cloud service provider network **1820A** may send a route for cloud service provider network **1820A** to PE **1804A** via a routing protocol (e.g., eBGP) peering connection with PE **1804A**. PE **1804A** associates the route with a hub-and-spoke network, which may have an associated VRF, that includes spoke PE router **1802A**. PE **1804A** then exports the route to PE router **1802A**; PE router **1804A** may export the route specifying PE router **1804A** as the next hop router, along with a label identifying the hub-and-spoke network. PE router **1802A** sends the route to PE router **1810B** via a routing protocol connection with PE **1810B**. PE router **1802A** may send the route after adding an autonomous system number of the cloud exchange point **1803** (e.g., to a BGP autonomous system path (AS_PATH) attribute) and specifying PE router **1802A** as the next hop router. Cloud exchange point **1803** is thus an autonomous system “hop” in the path of the autonomous systems from customers **1808** to cloud service providers **1820** (and vice-versa), even though the cloud exchange point **1803** may be based within a data center. PE router **1810B** installs the route to a routing database, such as a BGP routing information base (RIB) to provide layer 3 reachability to cloud service provider network **1820A**. In this way, cloud exchange point **1803** “leaks” routes from cloud service provider networks **1820** to customer networks **1808**, without cloud service provider networks **1820** to customer networks **1808** requiring a direct layer peering connection.

PE routers **1810B**, **1802A**, **1804A**, and **1812A** may perform a similar operation in the reverse direction to forward routes originated by customer network **1808B** to PE **1812A** and thus provide connectivity from cloud service provider network **1820A** to customer network **1808B**. In the example of virtual circuit **1830B**, PE routers **1812B**, **1804A**, **1802A**, and **1810B** exchange routes for customer network **1808B** and cloud service provider **1820B** in a manner similar to that described above for establishing virtual circuit **1830B**. As a result, cloud exchange point **1803** within data center **1800** internalizes the peering connections that would otherwise be established between PE **1810B** and each of PEs **1812A**, **1812B** so as to perform cloud aggregation for multiple layer 3 cloud services provided by different cloud service provider networks **1820A**, **1820B** and deliver the multiple, aggrega-

gated layer 3 cloud services to a customer network **1808B** having a single access link **1816B** to the cloud exchange point **1803**. Absent the techniques described herein, fully interconnecting customer networks **1808** and cloud service provider networks **1820** would require 3x3 peering connections between each of PEs **1810** and at least one of PEs **1812** for each of cloud service provider networks **1820**. For instance, PE **1810A** would require a layer 3 peering connection with each of PEs **1812**. With the techniques described herein, cloud exchange point **1803** may fully interconnect customer networks **1808** and cloud service provider networks **1820** with one peering connection per site PE (i.e., for each of PEs **1810** and PEs **1812**) by internalizing the layer 3 peering and providing data center-based “transport” between cloud access and cloud aggregate interfaces.

In examples in which IP/MPLS fabric **1801** implements BGP/MPLS IP VPNs or other IP-VPNs that use route targets to control route distribution within the IP backbone, PEs **1804** may be configured to import routes from PEs **1802** and to export routes received from PEs **1812**, using different asymmetric route targets. Likewise, PEs **1802** may be configured to import routes from PEs **1804** and to export routes received from PEs **1810** using the asymmetric route targets. Thus, PEs **1802**, **1804** may be configured to implement advanced L3VPNs that each includes a basic backbone L3VPN of IP/MPLS fabric **1801** together with extranets of any of customer networks **1808** and any of cloud service provider networks **1820** attached to the basic backbone L3VPN. Each advanced L3VPN constitutes a cloud service delivery network from a cloud service provider network **1820** to one or more customer networks **1808**, and vice-versa. In this way, cloud exchange point **1803** enables any cloud service provider network **1820** to exchange cloud service traffic with any customer network **1808** while internalizing the layer 3 routing protocol peering connections that would otherwise be established between pairs of customer networks **1808** and cloud service provider networks **1820** for any cloud service connection between a given pair. In other words, the cloud exchange point **1803** allows each of customer networks **1808** and cloud service provider networks **1820** to establish a single (or more for redundancy or other reasons) layer 3 routing protocol peering connection to the data center-based layer 3 cross-connect. By filtering routes from cloud service provider networks **1820** to customer networks **1808**, and vice-versa, PEs **1802**, **1804** thereby control the establishment of virtual circuits **1830** and the flow of associated cloud service traffic between customer networks **1808** and cloud service provider networks **1820** within a data center **1800**. Routes distributed into MP-iBGP mesh **183** may be VPN-IPv4 routes and be associated with route distinguishers to distinguish routes from different sites having overlapping address spaces.

Interconnection platform **103** may receive service requests for creating, reading, updating, and/or deleting end-to-end services of the cloud exchange point **1803**. In response, interconnection platform **103** may configure PEs **1802**, **1804** and/or other network infrastructure of IP/MPLS fabric **1801** to provision or obtain performance or other operations information regarding the service. Operations for provisioning a service and performed by interconnection platform **103** may include configuring or updating VRFs, installing SDN forwarding information, configuring LSPs or other tunnels, configuring BGP, configuring access links **1816** and aggregation links **1822**, or otherwise modifying the configuration of the IP/MPLS fabric **1801**. Other operations may include making service requests to an orchestra-

tion system for cloud service provider networks **1820**, as described in further detail below.

FIG. **19** is a block diagram illustrating an example of a data center-based cloud exchange point in which routers of the cloud exchange point are configured by interconnection platform **103** with VPN routing and forwarding instances for routing and forwarding aggregated service traffic from multiple cloud service provider networks to a customer network, according to techniques described herein. In this example, to establish virtual circuits **1830A-1830B**, PE routers **1802A** and **1804A** of IP/MPLS fabric **1801** are configured with VRFs. PE **1802A** is configured with VRFs **1902A** and **1904A**, while PE **1804A** is configured with VRFs **1902B** and **1904B**. VRF **1902A** is configured to import routes exported by VRF **1902B**, and VRF **1902B** is configured to import routes exported by VRF **1902A**. The configuration may include asymmetric route targets for import/export between VRFs **1902A**, **1902B**. VRF **1904A** is configured to import routes exported by VRF **1902B**, and VRF **1902B** is configured to import routes exported by VRF **1902A**. The configuration may include asymmetric route targets for import/export between VRFs **1902A**, **1902B**.

In this example, PE **1804A** operates BGP or other route distribution protocol peering connections **1906B**, **1908B** with respective PEs **1812A**, **1812B** to exchange routes with respective cloud service provider networks **1820A**, **1820B**. PE **1802A** operates a BGP or other route distribution protocol peering connection **1910** with PE **1810B** to exchange routes with customer network **1808B**. In some examples, PEs **1802A**, **1804A** may be statically configured with routes for the site networks.

An administrator or an interconnection platform described herein for cloud exchange point **1803** may configure PEs **1802A**, **1804A** with the VRF **1902A-1902B**, **1904A-1904B** in order to leak routes between PEs **1812** and PE **1810B** and facilitate layer 3 connectivity for end-to-end IP paths illustrated here by virtual circuits **1830**, while potentially optimizing the end-to-end IP paths by fostering data center-based or at least metro-based connectivity. Cloud exchange point **1803** may thus provide dedicated cloud service provider access to customer network **1808B** by way of private and/or public routes for the cloud service provider networks **1820**. In the northbound direction, cloud exchange point **1803** may provide dedicated cloud service provider distribution to multiple customer networks **1808** by way of private and/or public routes for the customer networks **1808**. Neither PE **1810B** nor any of PEs **1802A**, **1804A** need access to the full Internet BGP routing table in order to reach cloud service provider networks **1820** or customer networks **1808**. Moreover, PEs **1802A**, **1804A** may be configured to aggregate customer/CSP routes and/or service traffic based on any one or more of physical, IP, service, and VRFs.

The techniques described herein may be implemented in hardware, software, firmware, or any combination thereof. Various features described as modules, units or components may be implemented together in an integrated logic device or separately as discrete but interoperable logic devices or other hardware devices. In some cases, various features of electronic circuitry may be implemented as one or more integrated circuit devices, such as an integrated circuit chip or chipset.

If implemented in hardware, this disclosure may be directed to an apparatus such as a processor or an integrated circuit device, such as an integrated circuit chip or chipset. Alternatively or additionally, if implemented in software or firmware, the techniques may be realized at least in part by a computer-readable data storage medium comprising

instructions that, when executed, cause a processor to perform one or more of the methods described above. For example, the computer-readable data storage medium may store such instructions for execution by a processor.

A computer-readable medium may form part of a computer program product, which may include packaging materials. A computer-readable medium may comprise a computer data storage medium such as random access memory (RAM), read-only memory (ROM), non-volatile random access memory (NVRAM), electrically erasable programmable read-only memory (EEPROM), Flash memory, magnetic or optical data storage media, and the like. In some examples, an article of manufacture may comprise one or more computer-readable storage media.

In some examples, the computer-readable storage media may comprise non-transitory media. The term “non-transitory” may indicate that the storage medium is not embodied in a carrier wave or a propagated signal. In certain examples, a non-transitory storage medium may store data that can, over time, change (e.g., in RAM or cache).

The code or instructions may be software and/or firmware executed by processing circuitry including one or more processors, such as one or more digital signal processors (DSPs), general purpose microprocessors, application-specific integrated circuits (ASICs), field-programmable gate arrays (FPGAs), or other equivalent integrated or discrete logic circuitry. Accordingly, the term “processor,” as used herein may refer to any of the foregoing structure or any other structure suitable for implementation of the techniques described herein. In addition, in some aspects, functionality described in this disclosure may be provided within software modules or hardware modules.

What is claimed is:

1. A system comprising:

one or more cloud exchanges, wherein each cloud exchange of the one or more cloud exchanges includes interconnection assets for connecting networks of customers of a cloud exchange provider; and

an interconnection platform configured for execution by one or more computing devices, wherein the interconnection platform comprises:

one or more application programming interfaces (APIs) that include endpoints representing different resources of the one or more cloud exchanges to provide, to the customers, programmable access to interconnection assets of the one or more cloud exchanges;

one or more cloud exchange API services for accessing services of the interconnection platform to modify network infrastructures of any of the one or more cloud exchanges,

wherein the interconnection platform is configured to receive, from a customer device associated with a first customer of the customers, a first request invoking a first endpoint of the endpoints, the first request requesting a virtual circuit be configured in the one or more cloud exchanges to enable communications between a port of the one or more cloud exchanges for the first customer and a first cloud service,

wherein the interconnection platform is configured to receive, from a provider device associated with a cloud service provider for the first cloud service, a second request invoking the first endpoint of the endpoints, and wherein the interconnection platform is configured to, in response to determining the second request indicates the cloud service provider accepts the virtual circuit, orchestrate the cloud exchange API services to modify

the corresponding network infrastructures of the one or more cloud exchanges to create the virtual circuit to enable communications between the port of the one or more cloud exchanges for the first customer and the first cloud service.

2. The system of claim 1, wherein the interconnection platform is configured to, in response to determining the second request indicates the cloud service provider rejects the virtual circuit, output a notification message to the customer device that the virtual circuit has been rejected.

3. The system of claim 1, wherein, to orchestrate the cloud exchange API services, the interconnection platform is configured to use a first API service of the cloud exchange API services to invoke a microservice, provided by the cloud service provider, to enable a port for the first cloud service.

4. The system of claim 1, wherein a cloud service provider network of the cloud service provider is connected to one or more ports of the one or more cloud exchanges first cloud exchange, wherein the second request, received from the provider device, specifies a first port of the one or more ports of the one or more cloud exchanges first cloud exchange, and wherein, to orchestrate the cloud exchange API services, the interconnection platform is configured to create the virtual circuit to enable communications between the port for the first customer to the first port specified in the second request.

5. The system of claim 1, wherein the first request, received from the first customer, specifies a metropolitan area, wherein the interconnection platform is configured to, based on the metropolitan area is located, orchestrate the cloud exchange API services to modify the network infrastructure of a cloud exchange of the one or more cloud exchanges that is located in the metropolitan area to create the virtual circuit.

6. The system of claim 5, wherein, to orchestrate the cloud exchange API services, the interconnection platform is configured to invoke a metro service to validate the metropolitan area and to modify, in response to receiving an indication from the metro service that the metropolitan area is valid, the network infrastructure of the cloud exchange of the one or more cloud exchanges that is located in the metropolitan area to create the virtual circuit.

7. The system of claim 1, wherein the interconnection platform is configured to receive, from the customer device, a third request invoking a metro endpoint of the endpoints, and wherein the interconnection platform is configured to, in response to the third request, output a list of metropolitan areas in which a cloud exchange is located or in which the first customer has purchased a port of the cloud exchange provider.

8. The system of claim 1, wherein the interconnection platform is configured to receive, from the customer device, a third request invoking a metro endpoint of the endpoints and including a cloud_exchange_enabled flag, and wherein the interconnection platform is configured to, in response to the third request, filter a list of metropolitan areas to generate and output a list of metropolitan areas in which a cloud exchange is located.

9. The system of claim 1, wherein the interconnection platform is configured to receive, from the customer device, a third request invoking a port endpoint of the endpoints, wherein the interconnection platform is configured to, in response to the third request, output a list of port structures for ports purchased by the first customer from the cloud exchange provider, and wherein each port structure includes a port identifier for an owned port, a metropolitan area in which the owned port is located, and a data center identifier for a data center in which the owned port is located.

10. The system of claim 9, wherein the third request specifies a metropolitan area, and wherein the interconnection platform is configured to, in response to the third request, filter ports that are purchased by the first customer to generate the list of port structures to include only port structures for owned ports located in a data center in the specified metropolitan area.

11. The system of claim 9, wherein the third request specifies a metropolitan area and a data center within the metropolitan area, and wherein the interconnection platform is configured to, in response to the third request, filter ports that are purchased by the first customer to generate the list of port structures to include only port structures for owned ports located in the specified metropolitan area and the specified data center.

12. The system of claim 1, wherein the interconnection platform is configured to receive, from the customer device, a third request invoking a cloud services endpoint of the endpoints, and wherein the interconnection platform is configured to, in response to the third request, output a list of cloud services data structures specifying cloud services available at the one or more cloud exchanges.

13. The system of claim 12, wherein each of the cloud services data structures indicates a cloud service name of a cloud service, a metropolitan area in which the cloud service is available, and a list of data centers in the metropolitan area in which the cloud service is available.

14. An interconnection platform for a plurality of one or more cloud exchanges, comprising:
 one or more processors coupled to memory;
 one or more application programming interfaces (APIs) that include endpoints representing different resources of the one or more cloud exchanges to provide, to customers of a cloud exchange provider of the one or more cloud exchanges, programmable access to interconnection assets of the one or more cloud exchanges; and
 one or more cloud exchange API services for accessing services of the interconnection platform to modify network infrastructures of any of the one or more cloud exchanges, wherein the one or more processors are configured to receive, from a customer device associated with a first customer of the customers, a first request invoking a first endpoint of the endpoints, the first request requesting a virtual circuit be configured in the one or more cloud exchanges to enable communications between a port for the first customer and a first cloud service, wherein the one or more processors are configured to receive, from a provider device associated with a cloud

81

service provider for the first cloud service, a second request invoking the first endpoint of the endpoints, and wherein the one or more processors are configured to, in response to determining the second request indicates the cloud service provider accepts the virtual circuit, orchestrate the cloud exchange API services to modify the corresponding network infrastructures of the one or more cloud exchanges to create the virtual circuit to enable communications between the port for the first customer and the first cloud service.

15. A method comprising:

receiving, by an interconnection platform for one or more cloud exchanges located in respective metropolitan areas, from a customer device associated with a first customer of a cloud exchange provider of the one or more cloud exchanges, a first request invoking a first endpoint of endpoints, the first request requesting a virtual circuit be configured in the one or more cloud exchanges to enable communications between a port for the first customer and a first cloud service,

wherein the interconnection platform includes one or more application programming interfaces (APIs) that include the endpoints, the endpoints representing different resources of the one or more cloud exchanges to provide, to customers of a cloud exchange provider of the one or more cloud exchanges, programmable access to interconnection assets of the one or more cloud exchanges,

wherein the interconnection platform includes one or more cloud exchange API services for accessing services of the interconnection platform to modify network infrastructures of any of the one or more cloud exchanges;

receiving, by the interconnection platform from a provider device associated with a cloud service provider for the first cloud service, a second request invoking the first endpoint of the endpoints; and

orchestrating, by the interconnection platform, in response to determining the second request indicates the cloud service provider accepts the virtual circuit, the cloud exchange API services to modify the corresponding network infrastructures of the one or more cloud exchanges to create the virtual circuit to enable communications between the port for the first customer and the first cloud service.

82

16. The method of claim **15**,

wherein a cloud service provider network of the cloud service provider is connected to one or more ports of the one or more cloud exchanges,

wherein the second request, received from the provider device, specifies a first port of the one or more ports of the one or more cloud exchanges, and

wherein orchestrating the cloud exchange API services comprises creating the virtual circuit to enable communications between the port for the first customer to the first port specified in the second request.

17. The method of claim **15**, further comprising:

receiving, from the customer device, a third request invoking a metro endpoint of the endpoints; and outputting, in response to the third request, a list of metropolitan areas in which a cloud exchange is located or in which the first customer has purchased a port of the cloud exchange provider.

18. The method of claim **15**, further comprising:

receiving, from the customer device, a third request invoking a metro endpoint of the endpoints and including a cloud exchange enabled flag;

filtering, in response to the third request, a list of metropolitan areas to generate a list of metropolitan areas in which a cloud exchange is located; and

outputting the list of all metropolitan areas in which a cloud exchange is located.

19. The method of claim **15**, further comprising:

receiving, from the customer device, a third request invoking a port endpoint of the endpoints; and

outputting, in response to the third request, a list of port structures for ports purchased by the first customer from the cloud exchange provider,

wherein each port structure includes a port identifier for an owned port, a metropolitan area in which the owned port is located, and a data center identifier for a data center in which the owned port is located.

20. The method of claim **19**,

wherein the third request specifies a metropolitan area, the method further comprising:

filtering, in response to the third request, all ports that are purchased by the first customer to generate the list of port structures to include only port structures for owned ports located in a data center in the specified metropolitan area.

* * * * *