



US 20200059137A1

(19) **United States**

(12) **Patent Application Publication**
TAKANO et al.

(10) **Pub. No.: US 2020/0059137 A1**

(43) **Pub. Date: Feb. 20, 2020**

(54) **RELUCTANCE MOTOR AND MOTOR SYSTEM INCLUDING RELUCTANCE MOTOR**

Publication Classification

(51) **Int. Cl.**
H02K 11/215 (2006.01)
H02P 25/086 (2006.01)
H02K 1/14 (2006.01)
H02K 1/18 (2006.01)

(52) **U.S. Cl.**
 CPC *H02K 11/215* (2016.01); *H02K 1/185* (2013.01); *H02K 1/145* (2013.01); *H02P 25/086* (2013.01)

(71) Applicant: **Nidec Corporation**, Kyoto (JP)

(72) Inventors: **Yuichi TAKANO**, Kyoto (JP); **Keita FUKUSHIMA**, Kyoto (JP); **Tomohiro FUKUMURA**, Kyoto (JP)

(21) Appl. No.: **16/347,204**

(22) PCT Filed: **Oct. 27, 2017**

(86) PCT No.: **PCT/JP2017/038991**

§ 371 (c)(1),

(2) Date: **May 3, 2019**

(30) **Foreign Application Priority Data**

Nov. 4, 2016 (JP) 2016-216076

(57) **ABSTRACT**

An SR motor includes a rotor including N rotor salient poles where N is an integer of 2 or more, a stator including M stator salient poles where M is an integer of 3 or more, a shaft rotatably connected to the rotor, a sensor magnet that is fixed to an outer circumference of the shaft and includes an S pole and an N pole alternately arranged in the circumferential direction of the shaft, and three magnetic sensors opposed to the sensor magnet. The number of poles of the sensor magnet is N.

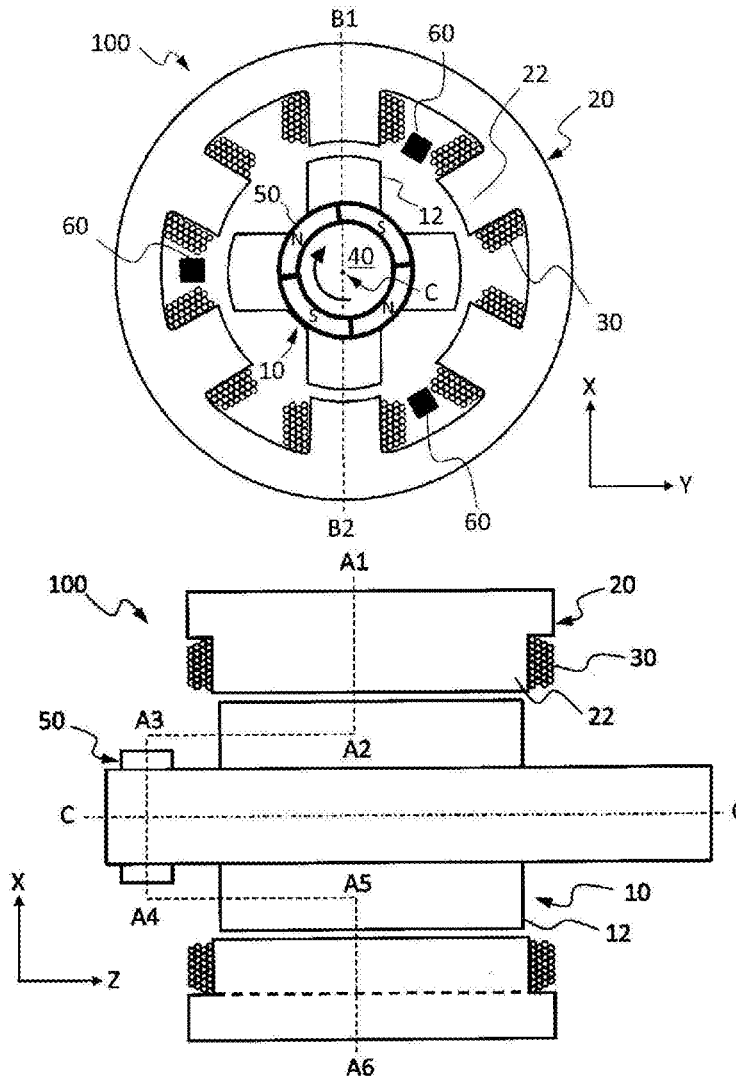

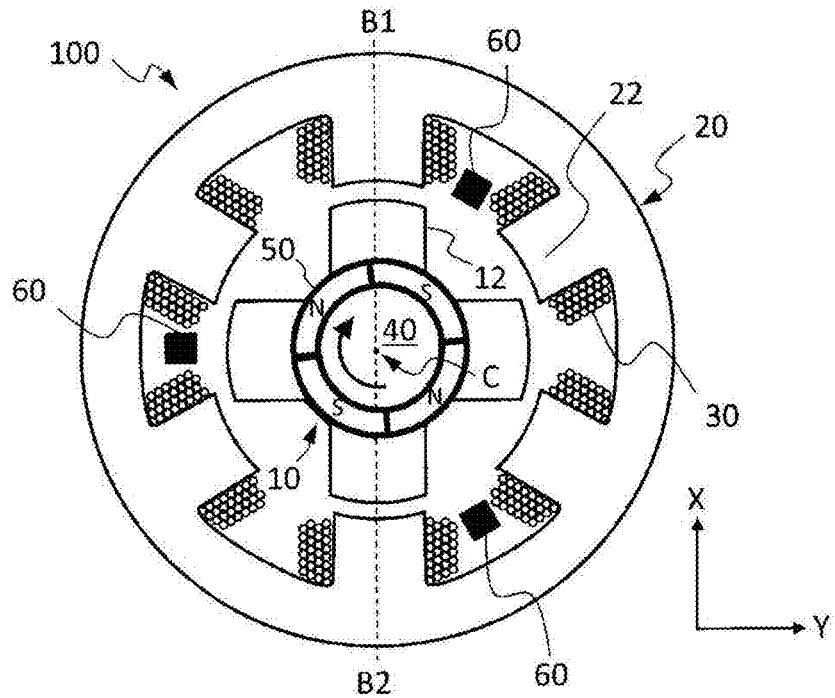

Fig.1A

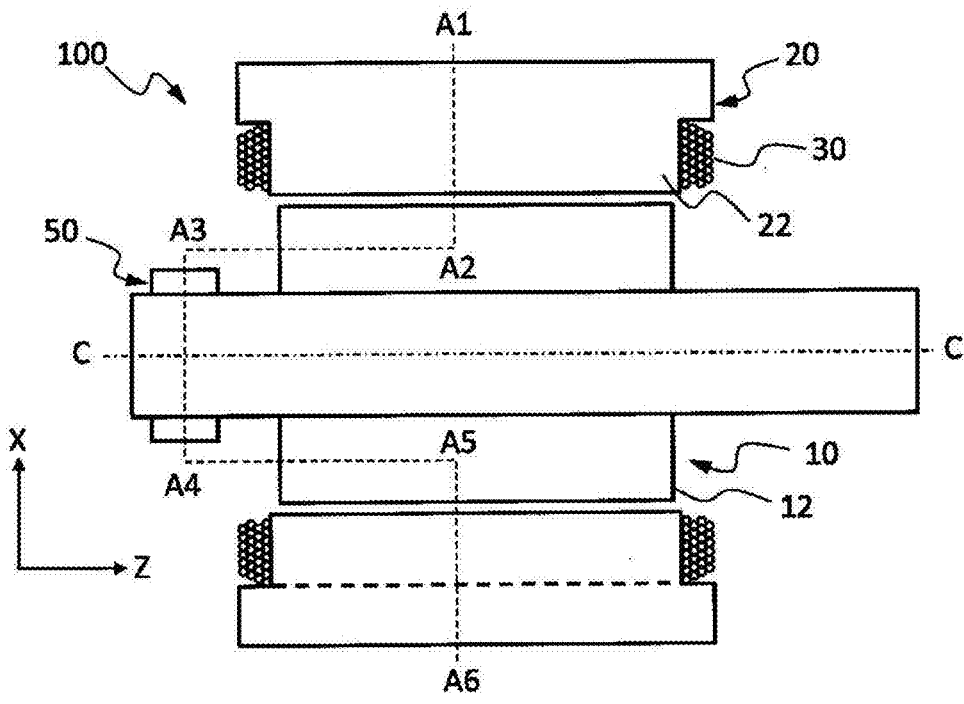

Fig.1B

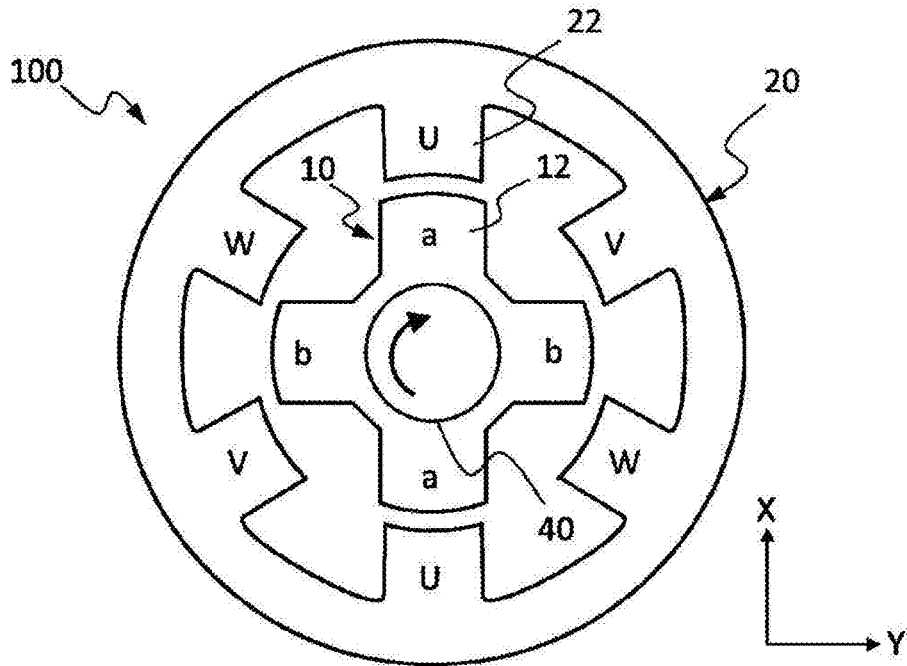

Fig.2

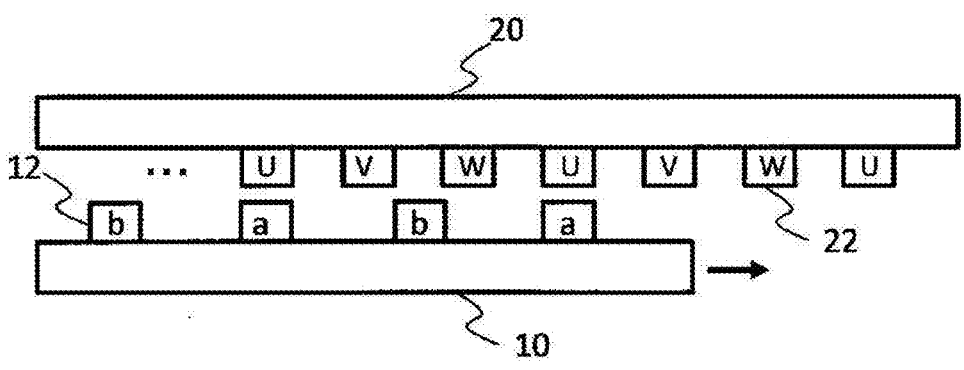

Fig.3

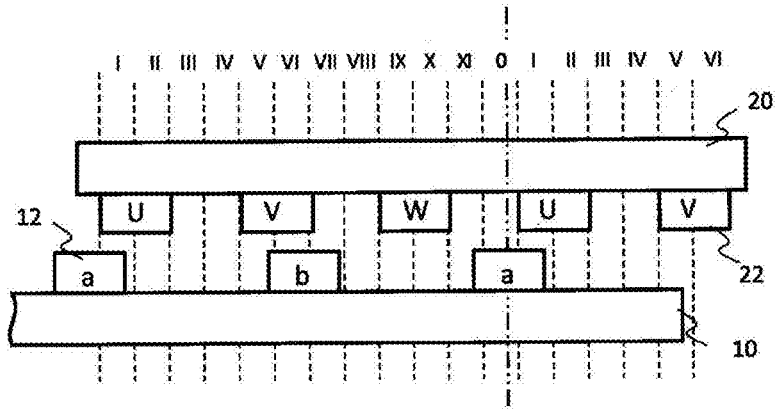

Fig.4A

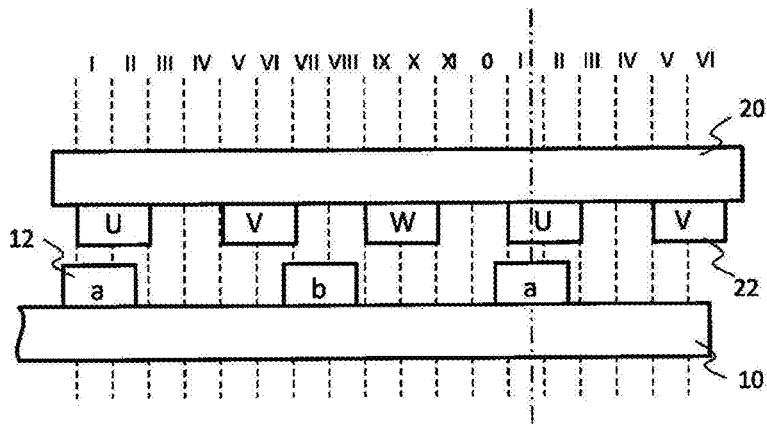

Fig.4B

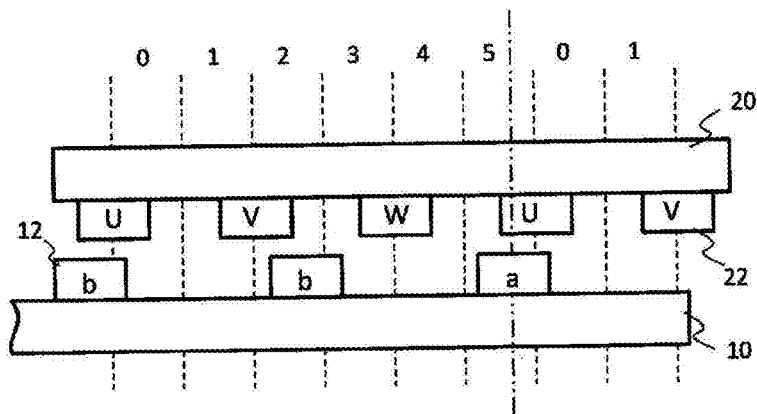

Fig.4C

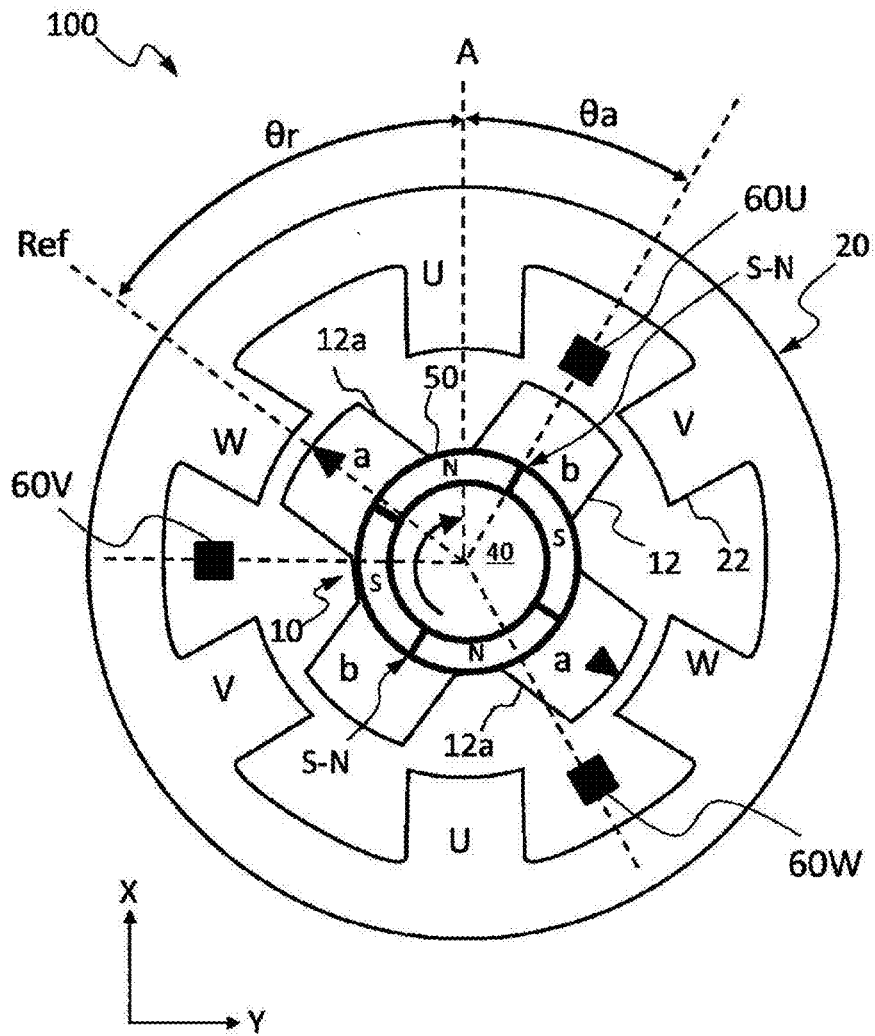

Fig.5

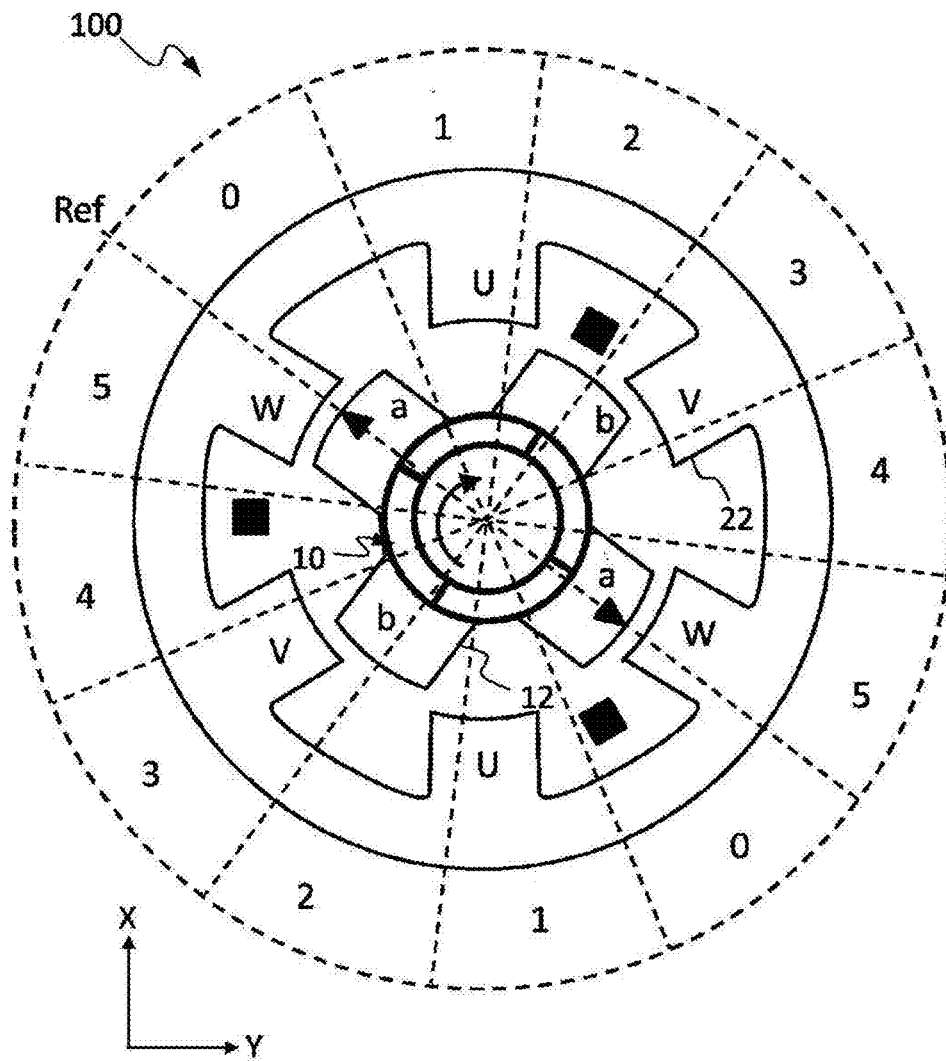

Fig.6

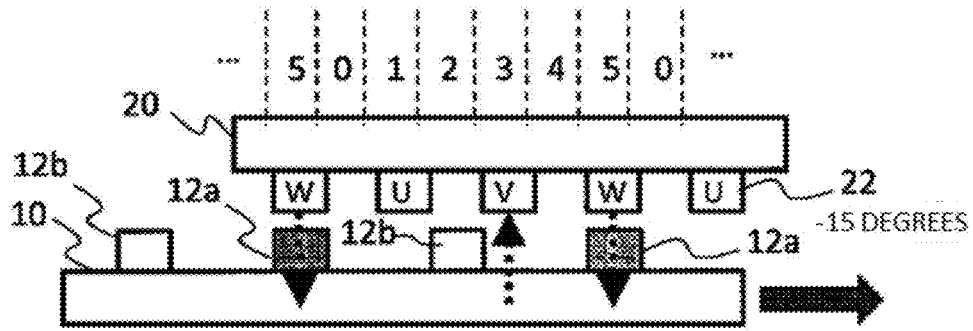

Fig.8A

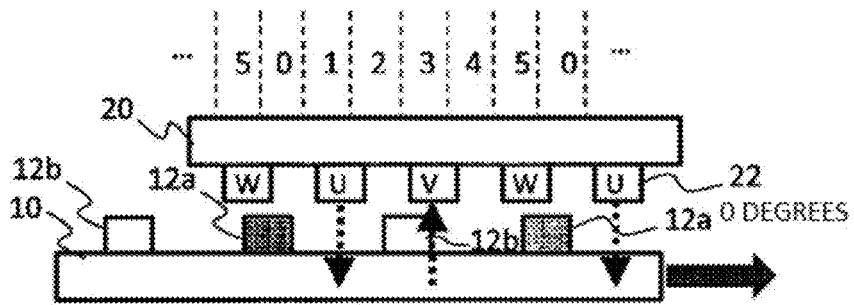

Fig.8B

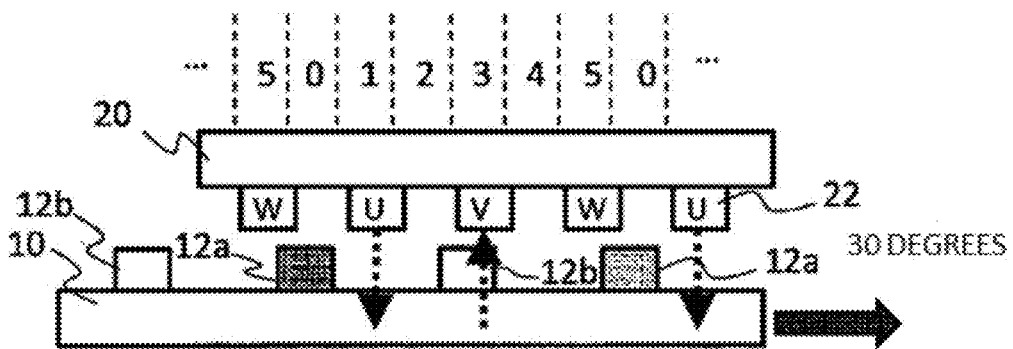

Fig.8C

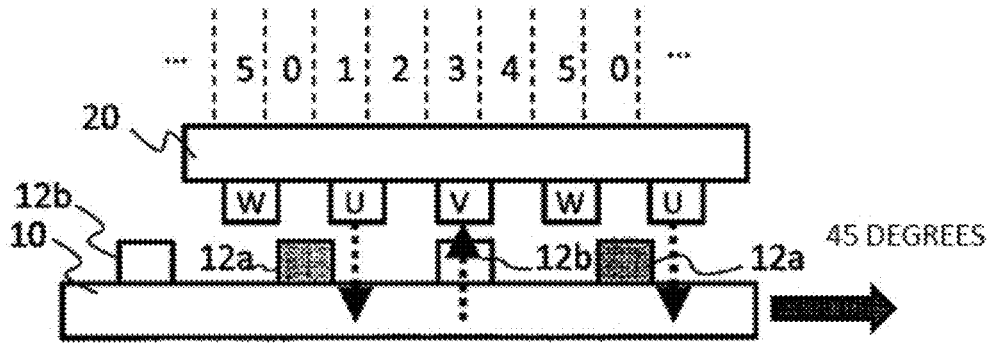

Fig. 8D

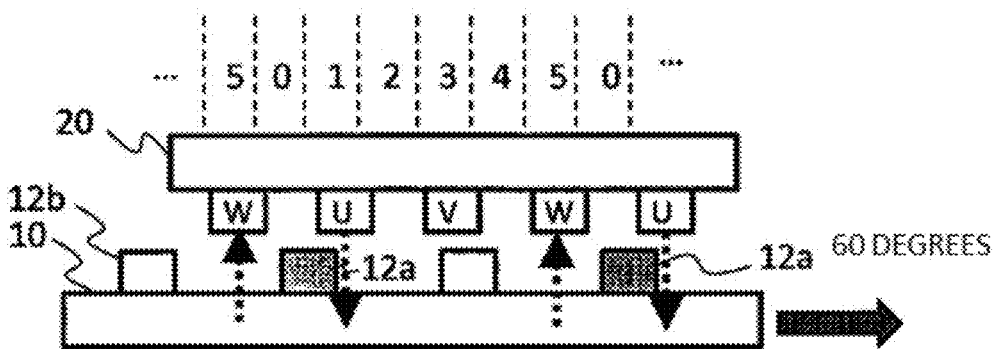

Fig. 8E

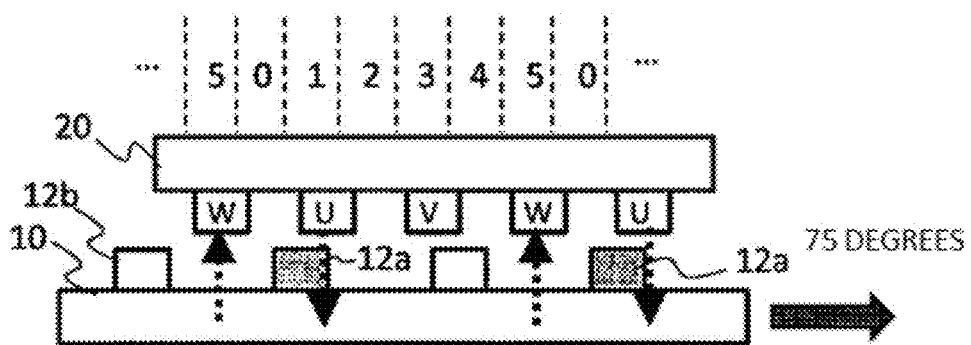

Fig. 8F

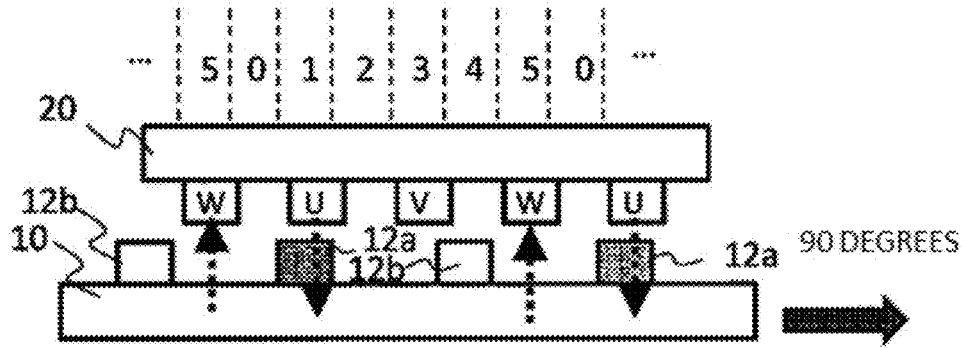

Fig.8G

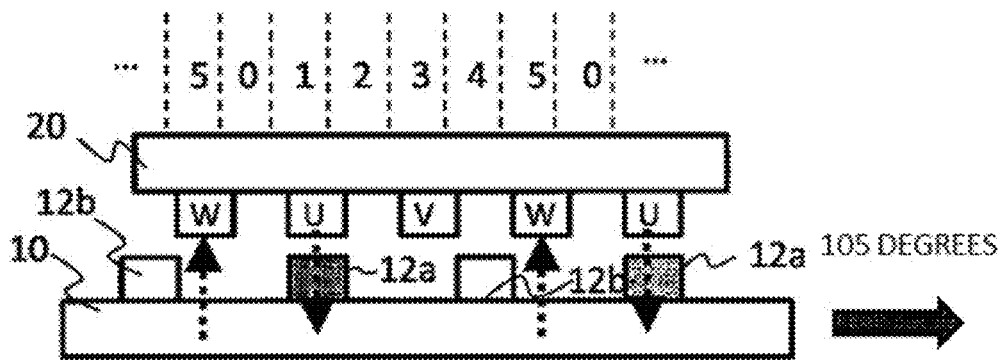

Fig.8H

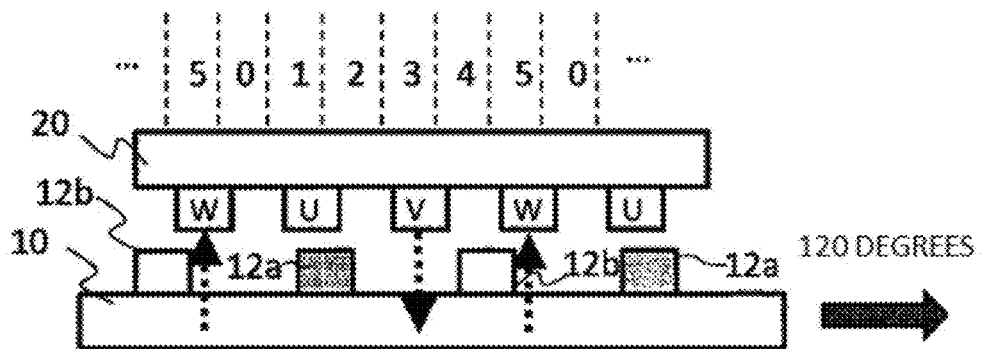

Fig.8I

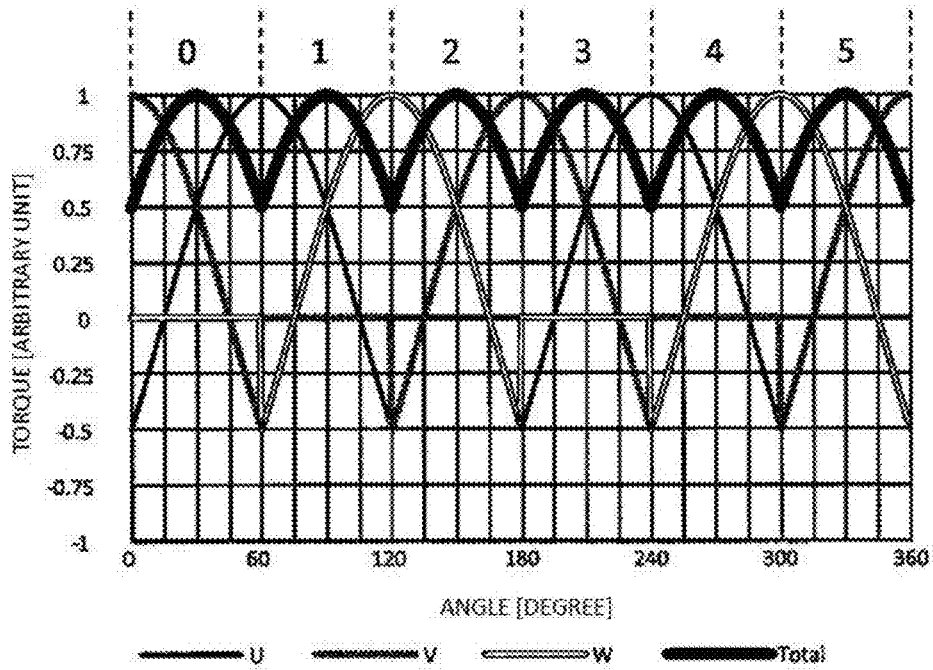

Fig.9

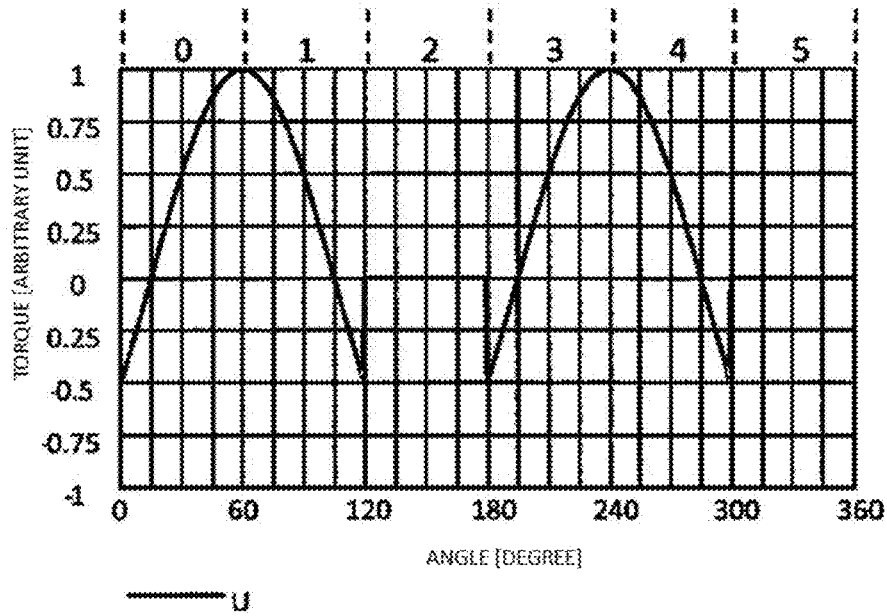

Fig.10A

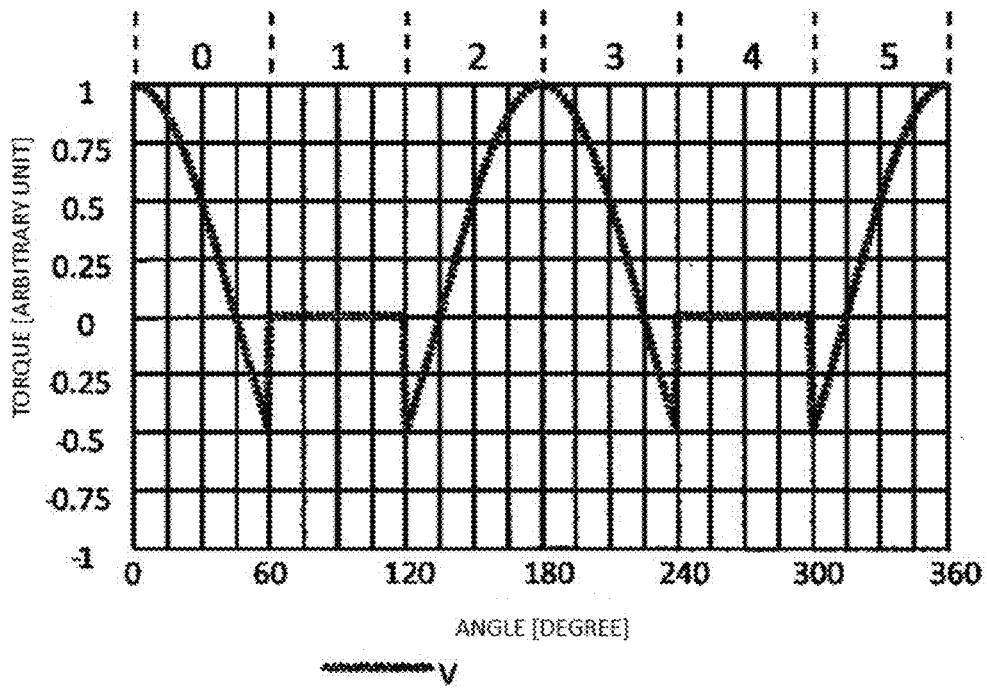

Fig.10B

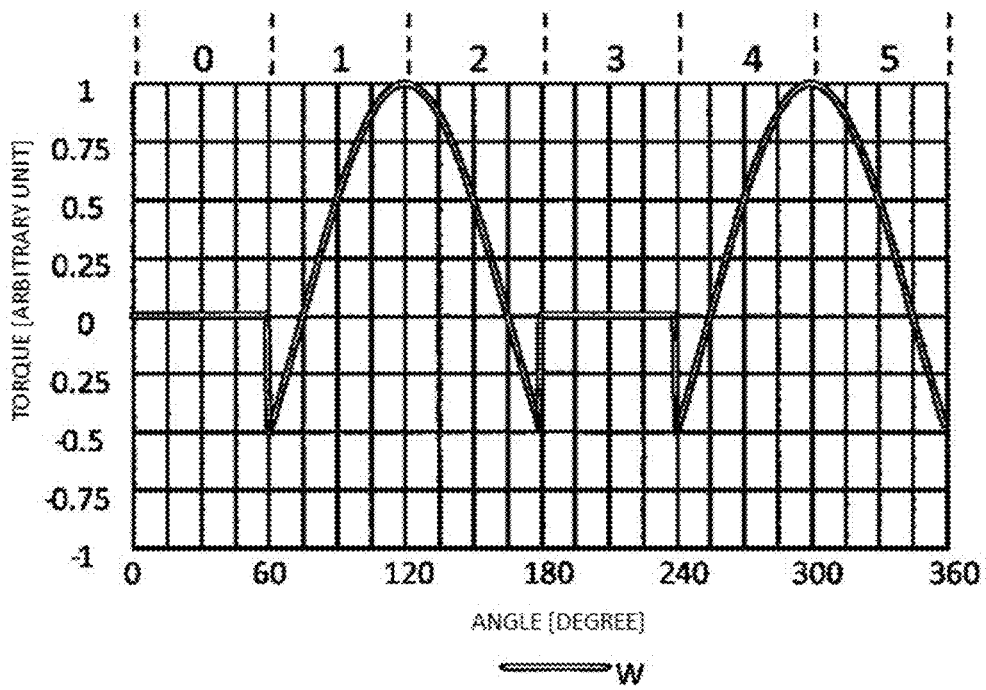

Fig.10C

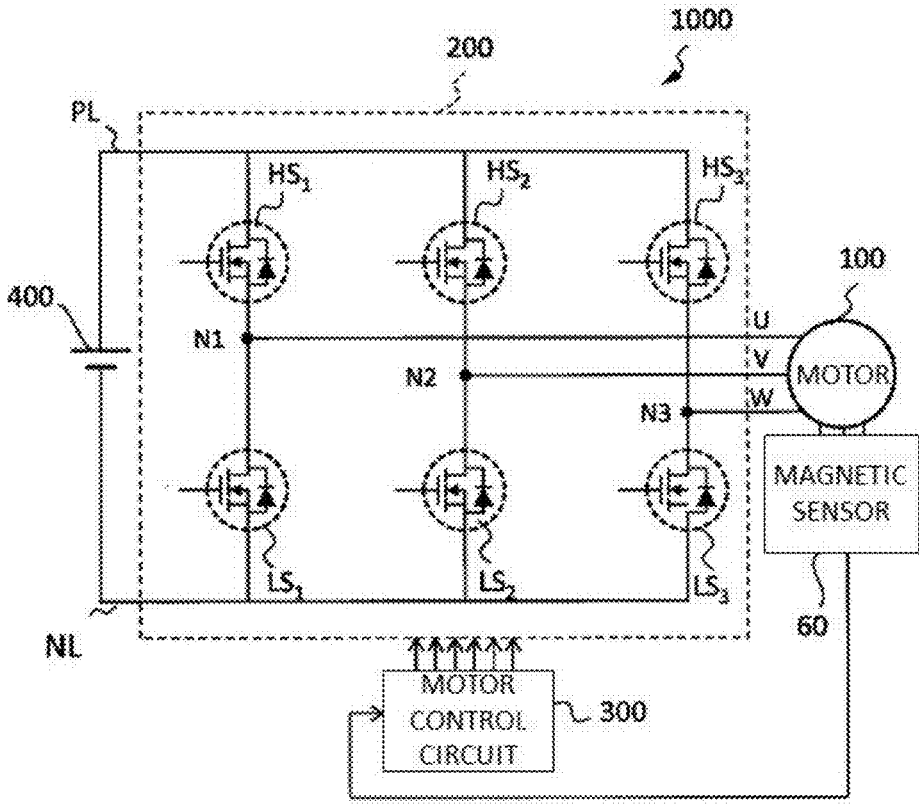

Fig.11

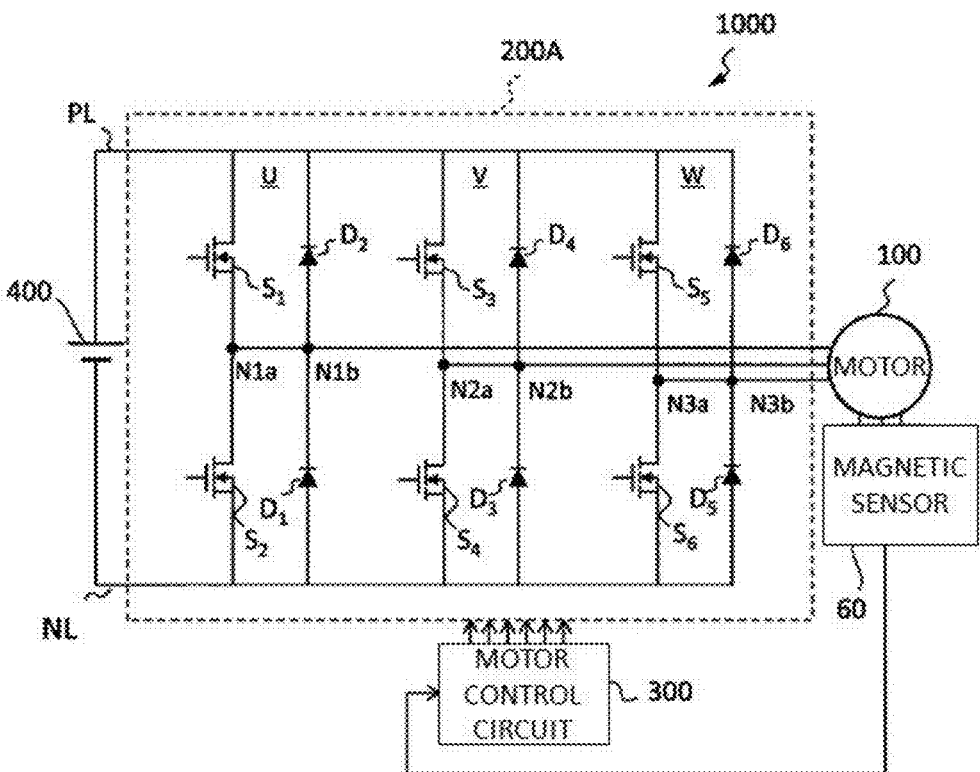

Fig.12

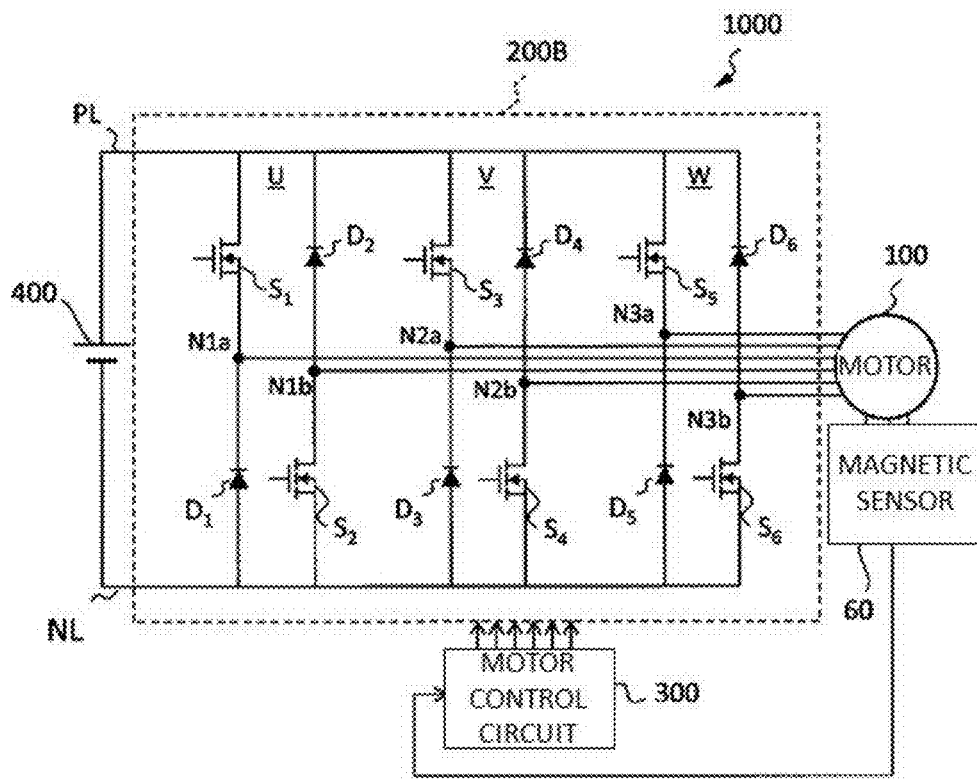

Fig.13

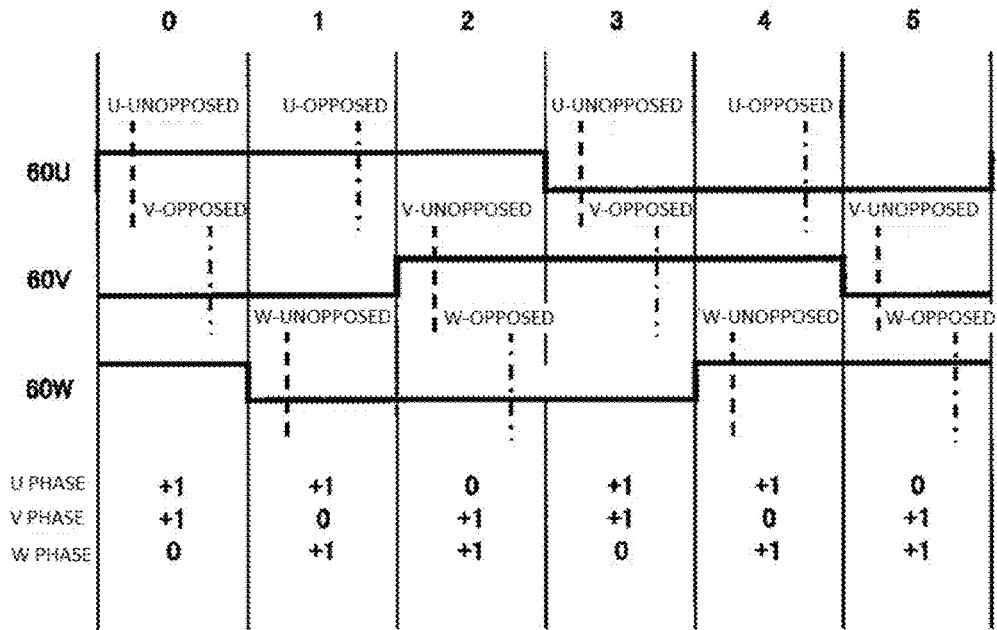

Fig.14

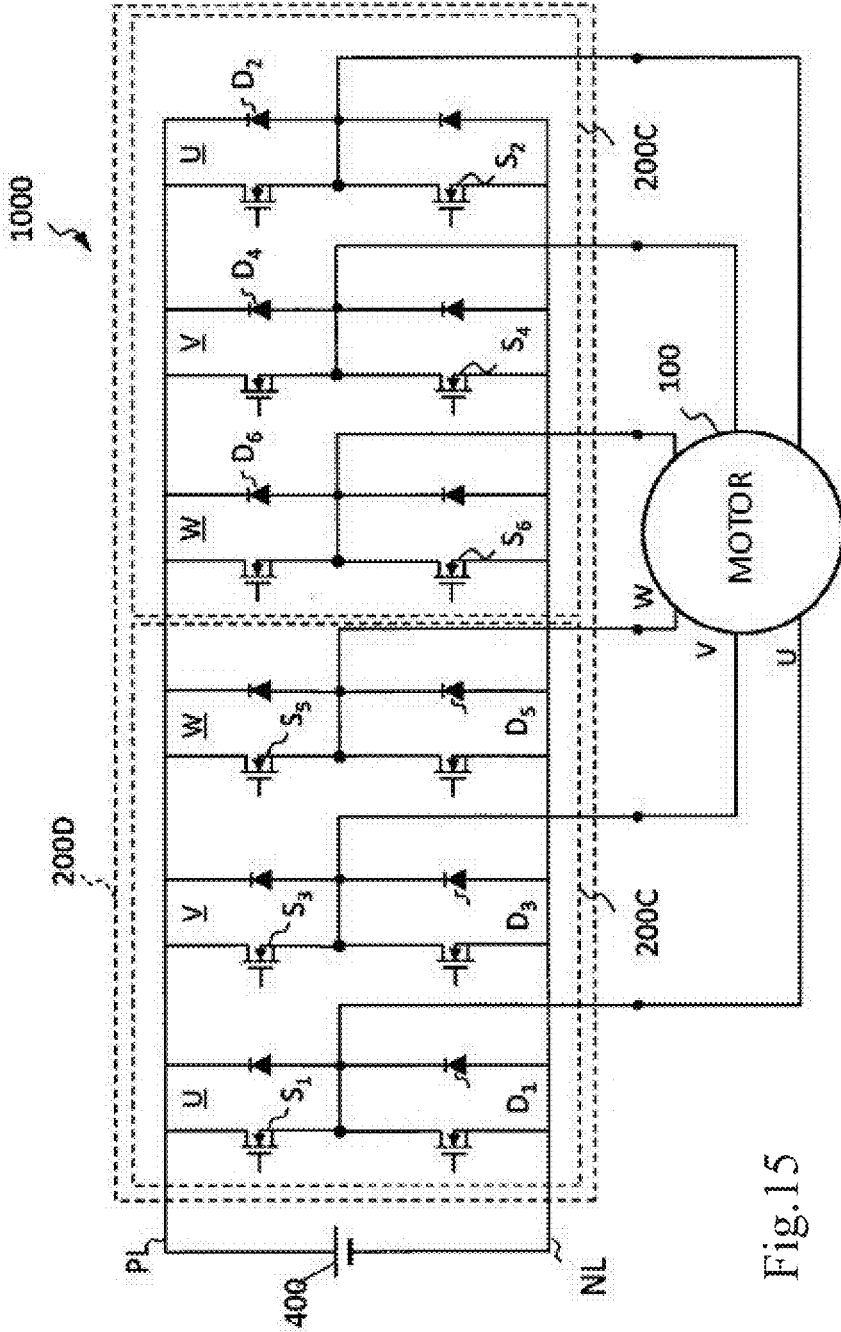

Fig.15

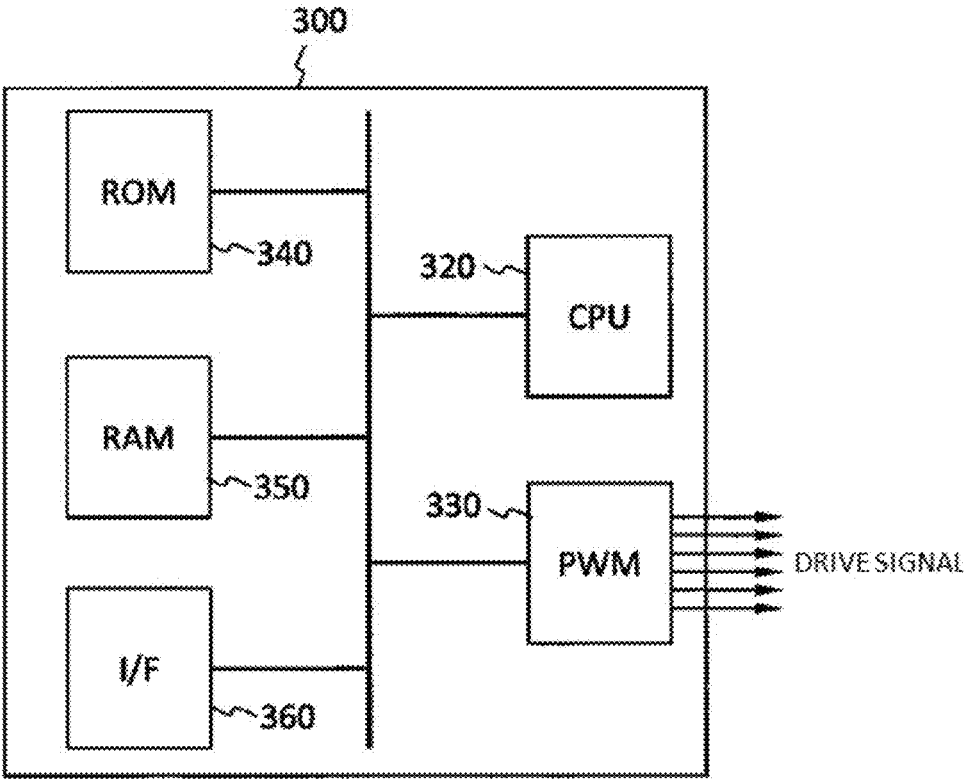

Fig.16

RELUCTANCE MOTOR AND MOTOR SYSTEM INCLUDING RELUCTANCE MOTOR

CROSS REFERENCE TO RELATED APPLICATIONS

[0001] This is the U.S. national stage of application No. PCT/JP2017/038991, filed on Oct. 27, 2017, and priority under 35 U.S.C. § 119(a) and 35 U.S.C. § 365(b) is claimed from Japanese Application No. 2016-216076, filed Nov. 4, 2016; the entire contents of which are incorporated herein by reference.

1. FIELD OF THE INVENTION

[0002] This application relates to a reluctance motor and a motor system including the reluctance motor.

2. BACKGROUND

[0003] Reluctance motors requiring no permanent magnet have been studied. The term “reluctance” means magnetic resistance (magnetic reluctance). The magnetic resistance refers to a degree of difficulty for magnetic flux to flow in a magnetic circuit. The reluctance motor performs rotational driving using a reluctance torque rather than a magnet torque caused by a permanent magnet. To generate the reluctance torque, a rotor and a stator have a double salient structure.

[0004] The reluctance motor is broadly classified into a switched reluctance motor and a synchronous reluctance motor. In the switched reluctance motor, self-inductance changes in accordance with the rotational position of the rotor, generating the reluctance torque. In the synchronous reluctance motor, both of self-inductance and mutual inductance change in accordance with the rotational position of the rotor, generating the reluctance torque.

[0005] As compared to a widespread permanent magnet motor and an induction motor, the reluctance motor has a different torque generation mechanism that requires more special control. Basic characteristics of the reluctance motor are not necessarily definite. Thus, the controller for the reluctance motor has to be independently designed in accordance with the structure of the adopted reluctance motor. Conventionally, in the switched reluctance motor, since a current is independently passed through each phase coil, an inverter for a half-bridge circuit rather than for a full-bridge circuit (also referred to as “H bridge circuit”) has been commonly used. The inverter for 3-phase full-bridge circuits has been used in a wide range of technical fields and is easily available as inexpensive mass-produced items, while the inverter for half-bridge circuits has a small stock of goods and needs to be independently designed for the reluctance motor.

[0006] As described above, it is difficult to adopt inexpensive mass-produced general-purpose items to controllers and inverters for the reluctance motor, requiring independently-designed expensive parts. This obstructs cost reduction of the motor system including the reluctance motor.

[0007] Conventionally, a motor controller for feeding a control signal to the switched reluctance motor is known. The motor controller is configured to operate by using a 3-phase full-bridge circuit inverter.

[0008] In the conventional motor, a resolver is used as a rotational angle sensor for detecting a rotational position of the rotor. The resolver is a rotational angle sensor capable of

detecting the angle with high accuracy, but is more expensive than a Hall element or a Hall IC. Conventionally, it is assumed that, to activate the reluctance motor, the rotational position of the rotor has to be correctly detected.

[0009] There is a demand for a reluctance motor capable of rotating the rotor in a desired direction without using an expensive rotational angle sensor such as a resolver or a rotary encoder.

SUMMARY

[0010] A reluctance motor according to an example embodiment of the present disclosure includes a rotor including N (N is an integer of 2 or more) rotor salient poles, a stator including M (M is an integer of 3 or more) stator salient poles, 3-phase coils to excite the stator salient poles, a shaft rotatably connected to the rotor, a sensor magnet that is fixed to an outer circumference of the shaft and includes an S pole and an N pole alternately arranged in a circumferential direction of the shaft, and three magnetic sensors opposed to the sensor magnet, and the number of poles of the sensor magnet is N.

[0011] A motor system according to an example embodiment of the present disclosure includes the above-mentioned reluctance motor, an inverter circuit electrically connected to the 3-phase coils of the reluctance motor, and a motor control circuit electrically connected to the inverter circuit. The motor control circuit receives outputs of the magnetic sensors, and outputs a drive signal to switch a voltage applied to the 3-phase coils while the rotor rotates by 360 degrees in an electrical angle, in accordance with a zone which is one of six angular zones and in which the rotor is located, the six angular zones being acquired by equally dividing 360 degrees in the electrical angle, and the inverter circuit applies the voltage to the 3-phase coils according to the drive signal.

[0012] The above and other elements, features, steps, characteristics and advantages of the present disclosure will become more apparent from the following detailed description of the example embodiments with reference to the attached drawings.

BRIEF DESCRIPTION OF THE DRAWINGS

[0013] FIG. 1A is a sectional view of an SR motor according to an example embodiment of the present disclosure when viewed from a sensor magnet side.

[0014] FIG. 1B is a sectional view taken along the line B1-B2 in FIG. 1A.

[0015] FIG. 2 is a schematic view of a cross section of an SR motor 100 perpendicular to the rotational center axis C.

[0016] FIG. 3 is a schematic view illustrating the relative positional relation between a rotor 10 and a stator 20 of the SR motor 100 in the circumferential direction of rotation.

[0017] FIG. 4A is a schematic view illustrating the relative positional relation between the rotor 10 and the stator 20 in the circumferential direction of rotation in the case where the range of 360 degrees in the electrical angle is divided into 12 angular zones 0 to XI.

[0018] FIG. 4B is a schematic view illustrating another relative positional relation between the rotor 10 and the stator 20 in the circumferential direction of rotation in the case where the range of 360 degrees in the electrical angle is divided into 12 angular zones 0 to XI.

[0019] FIG. 4C is a schematic view illustrating the relative positional relation between the rotor 10 and the stator 20 in the circumferential direction of rotation in the case where the range of 360 degrees in the electrical angle is divided into 6 angular zones 0 to 5.

[0020] FIG. 5 is a view of the SR motor according to the example embodiment of the present disclosure when viewed from the sensor magnet side.

[0021] FIG. 6 is a schematic view illustrating the state where 360 degrees in the electrical angle is divided into six angular zones 0 to 5.

[0022] FIG. 7 is a view illustrating the relation (excitation pattern) between a rotor position and the excitation state.

[0023] FIG. 8A is a view illustrating the relation between the rotor position and the excitation state in an example embodiment of the present disclosure.

[0024] FIG. 8B is another view illustrating the relation between the rotor position and the excitation state in an example embodiment of the present disclosure.

[0025] FIG. 8C is still another view illustrating the relation between the rotor position and the excitation state in an example embodiment of the present disclosure.

[0026] FIG. 8D is still another view illustrating the relation between the rotor position and the excitation state in an example embodiment of the present disclosure.

[0027] FIG. 8E is still another view illustrating the relation between the rotor position and the excitation state in an example embodiment of the present disclosure.

[0028] FIG. 8F is still another view illustrating the relation between the rotor position and the excitation state in an example embodiment of the present disclosure.

[0029] FIG. 8G is still another view illustrating the relation between the rotor position and the excitation state in an example embodiment of the present disclosure.

[0030] FIG. 8H is still another view illustrating the relation between the rotor position and the excitation state in an example embodiment of the present disclosure.

[0031] FIG. 8I is still another view illustrating the relation between the rotor position and the excitation state in an example embodiment of the present disclosure.

[0032] FIG. 9 is a graph illustrating the relation between the magnitude of the torque generated in the rotor 10 and the rotor position in an example embodiment of the present disclosure.

[0033] FIG. 10A is a graph illustrating a curve indicating the torque generated by the U-phase salient pole.

[0034] FIG. 10B is a graph illustrating a curve indicating the torque generated by the V-phase salient pole.

[0035] FIG. 10C is a graph illustrating a curve indicating the torque generated by the W-phase salient pole.

[0036] FIG. 11 is a circuit diagram of the motor system according to a non-limiting example embodiment of the present disclosure.

[0037] FIG. 12 is a circuit diagram of an example of another inverter circuit 200A including a 3-phase full-bridge circuit.

[0038] FIG. 13 is a circuit diagram of an example of an inverter circuit 200B including an asymmetric half-bridge inverter.

[0039] FIG. 14 is a view illustrating another relation (excitation pattern) between the rotor position and the excitation state of the stator salient pole in an example embodiment of the present disclosure.

[0040] FIG. 15 is a circuit diagram of an inverter circuit 200D including a plurality of 3-phase full-bridge inverters 200C.

[0041] FIG. 16 is a view illustrating the hardware configuration of a motor control circuit 300 in the motor system of an example embodiment of the present disclosure.

DETAILED DESCRIPTION

[0042] Non-limiting example embodiments of reluctance motors of the present disclosure will be described below.

[0043] First, referring to FIGS. 1A and 1B, the basic structure of the reluctance motor in the present example embodiment will be described below. The reluctance motor in the present example embodiment is a switched reluctance motor. Hereinafter, the “switched reluctance motor” will be referred to as merely “SR motor”.

[0044] FIG. 1A is a sectional view of an SR motor 100 in the present example embodiment when viewed from a sensor magnet side. FIG. 1B is a sectional view taken along a line B1-B2 in FIG. 1A. FIG. 1A illustrates a cross-section taken along a line A1-A2, a line A3-A4, and a line A5-A6 in FIG. 1B. FIGS. 1A and 1B illustrate a portion of a right-handed XYZ coordinate system including mutually-orthogonal X axis, Y axis, and Z axis. The cross-section illustrated in FIG. 1A is the cross-section when viewed from the negative side toward the positive side of the Z axis that is parallel to a rotational center axis C. In the present disclosure, the negative side of the Z axis is the side (left side in FIG. 1B) of a below-mentioned sensor magnet 50 of the SR motor 100. The orientation of the SR motor 100 in the drawings does not limit the orientation of the reluctance motor of the present disclosure in use.

[0045] In the present disclosure, when the motor is viewed from the negative side toward the positive side of the Z axis, that is, from the side of the sensor magnet (left side in FIG. 1B), clockwise rotation is defined as “normal rotation”. In this case, counterclockwise rotation is defined as “reverse rotation (counter rotation)”. A curved arrow in FIG. 1A represents the direction of “normal rotation (positive rotation)”.

[0046] The SR motor 100 in the present example embodiment includes a rotor 10 having four rotor salient poles 12 and a stator 20 having six stator salient poles 22. Like the rotor and the stator of the well-known SR motor, the rotor 10 and the stator 20 may have various shapes and dimensions according to use. The rotor and the stator 20 are preferably made of a soft magnetic material, for example, may be formed of stacked silicon steel plates of any shape.

[0047] The number of the rotor salient poles 12 is not limited to four, and may be N (N is an integer of 2 or more). The number of the stator salient poles 22 is not limited to six, and may be M (M is an integer of 3 or more). The number of the rotor salient poles 12 may be referred to as “pole number”, and the number of the stator salient poles 22 may be referred to as “slot number”. The “slot” in the stator 20 means a space (recess) between the two stator salient poles 22 adjacent in the circumferential direction. The number of slots is equal to the number of stator salient poles 22. The structure including the N rotor salient poles 12 and the M stator salient poles 22 may be referred to as “M-N structure” or “M slot N pole structure”. Hereinafter, the SR motor having the “6-4 structure” according to the example embodiment of the present disclosure will be described below. However, the reluctance motor of the present disclosure is

not limited to the example embodiment. For example, the motor may have the “3-2 structure” or the “6-2 structure”.

[0048] The SR motor **100** in the present example embodiment includes 3-phase coils **30** that excite the stator salient poles **22** and a rotating shaft **40** connected to the rotor **10**. The coil **30** in this example is concentrated winding, and is connected to an inverter (not illustrated in FIGS. **1A** and **1B**) as described later. The inverter applies a voltage for the operation of the SR motor **100** to the desired coil **30** to pass a current (drive current) to the coil **30**. When the current passes the coil **30**, the stator salient pole **22** in the coil **30** is excited to generate a magnetic flux. The magnetic flux is incident from the excited stator salient pole **22** to the near rotor salient pole **12** via a magnetic gap, generating a magnetic circuit closed in the rotor **10** and the stator **20**. When a current having a suitable magnitude corresponding to the rotational position of the rotor **10** passes each coil **30** at appropriate timing, the rotor **10** is rotated in a predetermined direction by a required torque. In the present disclosure, the 3-phase coils **30** are U, V, and W-phase coils, respectively. In the following description, the stator salient pole **22** around which the U-phase coil **30** is wound is referred to as “U-phase salient pole”, the stator salient pole **22** around which the V-phase coil is wound is referred to as “V-phase salient pole”, and the stator salient pole **22** around which the W-phase coil is wound is referred to as “W-phase salient pole”.

[0049] In general, the reluctance motor rotates in accordance with the same principle as the principle of an electromagnet attracting a piece of iron. The excited stator salient pole **22** corresponds to an “electromagnet”, and the rotor salient pole **12** near the excited stator salient pole **22** corresponds to a “piece of iron”. When the orientation of the current passing through the coil **30** is inverted, the direction of the generated magnetic flux is also inverted. However, the force with which the “electromagnet” attracts the “piece of iron” does not depend on the orientation of the current passing through the coil **30**.

[0050] The shaft **40** is rotatably supported by a bearing not illustrated. Since the shaft **40** is fixed to the rotor **10**, the rotor **10** rotates with the shaft **40**. The shaft **40** may transmit the torque to a load via a mechanical component such as a gear not illustrated.

[0051] The SR motor **100** includes the sensor magnet **50** fixed to the outer circumference of the shaft **40**, and a plurality of magnetic sensors **60** disposed opposed to the sensor magnet **50**. The sensor magnet **50** has S poles and N poles alternately arranged in the circumferential direction (rotational direction) of the shaft **40**. The sensor magnet **50** in the present example embodiment has four magnetic poles in total of the S pole, the N pole, the S pole, and the N pole which are arranged in the circumferential direction. Since the sensor magnet **50** is fixed to the shaft **40**, with the rotation of the rotor **10**, the sensor magnet **50** rotates around the rotational center axis C along with the shaft **40**. Meanwhile, the magnetic sensors **60** are fixed to the stator **20**. In response to a change in the magnetic flux or magnetic field, which is generated by the sensor magnet **50** rotating with the shaft **40**, each of the three magnetic sensors **60** outputs a current or voltage signal. Each of the magnetic sensors **60** may be a Hall IC. The Hall IC may detect timing at which the magnetic pole of the opposed sensor magnet **50** changes from the S pole to the N pole, changing the voltage level of an output signal from logical low (Low) to logical high

(High), and may detect timing at which the magnetic pole changes from the N pole to the S pole, changing the voltage level of the output signal from High to Low. By disposing the three Hall ICs that are magnetic sensors at predetermined angular intervals, the angular position of the rotor **10** may be detected based on the output signal from each of the Hall ICs.

[0052] In the SR motor **100** in the present example embodiment, the number of poles of the sensor magnet **50** (the sum of the number of the S pole and the number of the N pole) is four that is equal to the number of the rotor salient poles **12**. In other words, the number of poles of the sensor magnet **50** is equal to the number N of the rotor salient poles **12**. Conventionally, to appropriately rotate the rotor **10** in a predetermined direction at the start of the SR motor **100**, it has been considered that the position of the rotor **10** in a stopped state before rotation has to be correctly detected. Thus, the position of the rotor **10** has been conventionally detected using an expensive rotational angle sensor such as a resolver or a rotary encoder. In using the magnetic sensor such as a Hall IC, it has been considered to set the number of the poles of the sensor magnet **50** to be twice as many as the number N of the rotor salient poles **12** or more.

[0053] Referring to FIGS. **2** and **3**, the detection of the position of the rotor **10** is described in more detail. FIG. **2** schematically illustrates a cross section of the SR motor **100** in the present example embodiment, which is cut perpendicularly to the rotational center axis C. FIG. **2** illustrates a cross section taken along a line A1-A2, a cross section taken along a line A2-A5, and a cross section taken along a line A5-A6 when viewed from the sensor magnet side in FIG. **1B**. For simplification, FIG. **2** does not illustrate the coils **30**.

[0054] The symbols “U”, “V”, and “W” in FIG. **2** denote the “U-phase salient pole”, the “V-phase salient pole”, and the “W-phase salient pole” of the stator **20**, respectively. The symbols “a” and “b” in FIG. **2** each are assigned to a pair of rotor salient poles **12** having 360 degrees in an electrical angle (180 degrees in a mechanical angle) therebetween among the four rotor salient poles **12**. In the following description, the rotor salient pole **12** represented by the symbol “a” is referred to as “rotor salient pole **12a**”, and the rotor salient pole **12** represented by the symbol “b” is referred to as “rotor salient pole **12b**”.

[0055] FIG. **3** is a schematic view of the relative positional relation between the rotor **10** and the stator **20** in the circumferential direction of rotation. For simplification, FIG. **3** illustrates the arrangement relation in which a curved line extending in the circumferential direction of rotation is converted into a straight line extending in a lateral direction. In the example illustrated in FIG. **3**, the rotor **10** moves in the direction represented by an arrow with respect to the stator **20** in a stationary state. The direction represented by the arrow indicates the direction of “normal rotation”. The symbols “U”, “V”, and “W”, and the symbols “a” and “b” in FIG. **3** are assigned to the components corresponding to the components having the same symbols in FIG. **2**.

[0056] To move (normally rotate) the rotor **10** in the direction represented by the arrow in FIG. **3**, it is preferred to detect the position (angular position) of the rotor **10** with respect to the stator **20**, and select the salient pole to be excited from among the “U-phase salient pole”, the “V-phase salient pole”, and the “W-phase salient pole” according to the position detected. If the selection is inap-

appropriate, the rotor **10** is not able to acquire a torque in a particular direction and oscillates side to side in FIG. 3.

[0057] FIG. 4A illustrates an example in which the range of 360 degrees in an electrical angle from the “U-phase salient pole” where the stator **20** is present to the next “U-phase salient pole” through the “V-phase salient pole” and the “W-phase salient pole” is divided into 12 angular zones **0** to **XI**. The width of each angular zone is 30 degrees in the electrical angle. Here, the rotor salient pole **12** represented by the reference symbol “a” is noted. In the example illustrated in FIG. 4A, the central position (represented by a two-dot chain line in the figure) of the noted rotor salient poles **12a** in the circumferential direction is located in the angular zone **0**. In this case, the “U-phase salient pole” is selected and excited to generate a torque for moving the rotor **10** to the right. Assuming that, then, the rotor **10** moves to the right side to achieve the arrangement illustrated in FIG. 4B. At this time, the central position (two-dot chain line) of the noted rotor salient pole **12a** in the circumferential direction is located in the angular zone **I**. In a conventional manner, at the timing when the central position of the noted rotor salient pole **12a** in the circumferential direction moves from the angular zone **0** to the angular zone **I**, excitation of the “U-phase salient pole” is stopped, and the “W-phase salient pole” is selected and excited.

[0058] As described above, according to the technical common sense, it is assumed that the position of the rotor **10** has to be detected with accuracy of dividing the range of 360 degrees in the electrical angle into 12 angular zones (angular resolution of 30 degrees in the electrical angle). To achieve the resolution, it has been viewed preferable to set the number of poles of the sensor magnet **50** to twice as many as the number of salient poles **N** of the rotor **10** or more. On the contrary, it is sufficient for the reluctance motor of the present disclosure, for example, as illustrated in FIG. 4C, to divide the range of 360 degrees in the electrical angle into six angular zones. In this case, the number of poles of the sensor magnet **50** may be the number of salient poles of the rotor, that is, **N**. Even when the position detection accuracy (angular resolution) is reduced, the rotor **10** may be suitably rotated in a predetermined direction by performing driving as mentioned below.

[0059] Next, with reference to FIG. 5, the configuration of the SR motor **100** in the present example embodiment is described in more detail. Like FIG. 1A, FIG. 5 is a sectional view of the SR motor **100** when viewed from the sensor magnet side.

[0060] In the present example embodiment, the three magnetic sensors **60** are configured of a first magnetic sensor **60U** located at a first position, a second magnetic sensor **60V** located at a second position rotated from the first position by 120 degrees+360 degrees \times m in the electrical angle in the circumferential direction of the shaft **40**, and a third magnetic sensor **60W** located at a third position rotated from the first position by 240 degrees+360 degrees \times n in the circumferential direction of the shaft **40**. In the illustrated example, m and n are 1 and 0, respectively, but may be any other pair of integers. In the example illustrated in FIG. 5, the three magnetic sensors **60U**, **60V**, and **60W** are three Hall ICs located at intervals of 120 degrees in a mechanical angle.

[0061] In the exemplary arrangement illustrated in FIG. 5, the first position rotates clockwise by an angle θ_a from a direction **A** connecting the circumferential center to the

rotational center in the U-phase salient pole. In the present example embodiment, the angle θ_a is preferably 60 degrees in the electrical angle (30 degrees in the mechanical angle). The angle θ_a is preferably determined to reduce the effect of the magnetic flux leaked from the coil **30** of the stator salient poles **22** on the magnetic sensors **60** and is not limited to 60 degrees in the electrical angle. As long as the effect of the leaked magnetic flux is not exerted on the magnetic sensors **60**, the angle θ_a may be any angle.

[0062] In FIG. 5, the circumferential center of the rotor salient pole **12a** represented by the reference symbol “a” is expressed by a black triangle. In the state illustrated in FIG. 5, the circumferential center of the rotor salient pole **12a** is located at a “reference position (Ref)” rotated counterclockwise (reverse rotation) by an angle θ_r from the direction **A**. The angle θ_r in the preferred example embodiment is 105 degrees in the electrical angle. In the present example embodiment, this angle is 52.5 degrees in the mechanical angle. In the following description, the rotational angle (electrical angle) of the circumferential center in the rotor salient pole **12** with respect to the reference position (Ref) is defined as the rotational position of the rotor **10**, and is merely referred to as “rotor position”. In the state illustrated in FIG. 5, the rotor position is 0 degrees. When the rotor **10** normally rotates, the rotor position increases from 0 degrees.

[0063] In the exemplary arrangement illustrated in FIG. 5, when the rotor position is at 0 degrees, one of boundary positions (S-N) between the S poles and the N poles in the sensor magnet **50** is opposed to the first magnetic sensor **60U**. Accordingly, when the rotor position passes through the position of 0 degrees while the rotor **10** normally rotates, the voltage level of the output signal of the first magnetic sensor **60U** changes from Low to High. In the present example embodiment, at the timing when the voltage level of the output signal of the first magnetic sensor **60U** changes from Low to High, the excitation of the U-phase salient pole is started. The excitation of the U-phase salient pole continues until the rotor **10** rotates by 120 degrees in the electrical angle and the voltage level of the output signal of the second magnetic sensor **60V** changes from Low to High.

[0064] Referring to FIG. 6, in the present disclosure, as illustrated in FIG. 6, 360 degrees in the electrical angle is divided into six angular zones **0** to **5**. Then, according to the angular zone where the rotor position is located, the excitation of the U, V, and W-phase salient poles is switched. A period during which each of the U, V, W-phase salient poles is excited corresponds to a period during which the rotor **10** rotates by 120 degrees in the electrical angle.

[0065] Referring to FIG. 7, FIG. 7 is a view illustrating the relation (excitation pattern) between the rotor position and the excitation state of the stator salient pole in the present example embodiment. FIG. 7 illustrates, for each of the six angular zones **0** to **5**, the output signal level of the three magnetic sensors (Hall ICs) **60U**, **60V**, and **60W**, and the excitation state of the U-phase salient pole, the V-phase salient pole, and the W-phase salient pole. The width of one angular zone is 60 degrees in the electrical angle.

[0066] In FIG. 7, the output signal levels of the three magnetic sensors **60U**, **60V**, and **60W** each are represented by a thick solid line. These output signal levels cyclically change between Low and High at the timing when the rotor shifts by 180 degrees in the electrical angle.

[0067] In FIG. 7, the excitation state of the U-phase salient pole, the V-phase salient pole, and the W-phase salient pole

is identified in association with signs “+1”, “-1”, and “0”. “+1” and “-1” each mean that “a current passes through a coil in a first direction” and “a current passes through a coil in a second direction that is opposite to the first direction”. The sign “0” means that “no current passes”. As described above, the direction of the magnetic flux formed in the stator salient pole 22 depends on the orientation of the current passing through the coil 30. However, magnitude and orientation of the torque are not related to the orientation of the current passing through the coil 30. Accordingly, in the present disclosure, the orientation of the current passing through the coil 30 is arbitrary. The signs “+1” and “-1” illustrated in FIG. 7 may be inverted to the signs “-1” and “+1”, respectively, and all signs “-1” may be replaced with the signs “+1”. However, as described later, passing the current illustrated in FIG. 7 through the coil advantageously enables an inexpensive general-purpose inverter including a full-bridge circuit to be adopted.

[0068] How the positional relation between the rotor 10 and the stator 20 is changed by changing the excitation state of the U-phase salient pole, the V-phase salient pole, and the W-phase salient pole at the timing illustrated in FIG. 7 will be described below.

[0069] First, referring to FIG. 8A, FIG. 8A schematically illustrates the excitation state at the rotor position of -15 degrees (angular zone 5). The rotor position of the present disclosure is defined as the central position of the rotor salient pole 12a in the circumferential direction. In FIGS. 5 and 6, the central position of the rotor salient pole 12a in the circumferential direction is represented by the black triangle. In the state illustrated in FIG. 8A, a current “-1” passes through the coil around the V-phase salient pole, and a current “+1” passes through the coil around the W-phase salient pole. Thus, FIG. 8A illustrates an upward arrow through the V-phase salient pole and a downward arrow through the W-phase salient pole. Each of these arrows schematically represents the orientation of the magnetic flux in the salient pole generated by the excited stator salient pole 22. At the position illustrated in FIG. 8A, the rotor salient pole 12b near the V-phase salient pole is attracted to the V-phase salient pole to give a torque to the rotor 10. The rotor salient poles 12a near the W-phase salient pole is attracted to the W-phase salient pole. However, a force received by the rotor salient pole 12a is oriented to the radial outer side of the rotor 10 to give no torque to the rotor 10.

[0070] Next, referring to FIG. 8B, FIG. 8B schematically illustrates the excitation state at the rotor position of 0 degrees (the boundary between the angular zone 5 and the angular zone 0). The rotor position in this case is equal to the rotational position of the rotor 0 as illustrated in FIGS. 5 and 6. At this time, the magnetic sensor 60U detects the boundary between the S pole and the N pole in the sensor magnet 50, and the output signal level changes from Low to High. As a result, a current “-1” remains to pass through the coil around the V-phase salient pole, but a current passing through the coil around the W-phase salient pole stops. Instead, a current “+1” start to pass through the coil around the U-phase salient pole. Thus, FIG. 8B illustrates an upward arrow through the V-phase salient pole and a downward arrow through the U-phase salient pole. At the position illustrated in FIG. 8B, the rotor salient pole 12b near the V-phase salient pole is attracted to the V-phase salient pole to give a torque to the rotor 10.

[0071] Next, referring to FIG. 8C, FIG. 8C schematically illustrates the excitation state at the rotor position of 30 degrees (angular zone 0). A current “-1” passes through the coil around the V-phase salient pole, and a current “+1” passes through the coil around the U-phase salient pole. Thus, FIG. 8C illustrates an upward arrow through the V-phase salient pole and a downward arrow through the U-phase salient pole. At the position illustrated in FIG. 8C, the rotor salient poles 12b near the V-phase salient pole is attracted to the V-phase salient pole to give a torque to the rotor 10. The rotor salient poles 12a near the U-phase salient pole also starts to be attracted to the U-phase salient pole.

[0072] Next, referring to FIG. 8D, FIG. 8D schematically illustrates the excitation state at the rotor position of 45 degrees (angular zone 0). A current “-1” remains to pass through the coil around the V-phase salient pole, and a current “+1” remains to pass through the coil around the U-phase salient pole. At the position illustrated in FIG. 8D, even when the rotor salient poles 12b near the V-phase salient pole is attracted to the V-phase salient pole, a torque is not given to the rotor 10. On the contrary, the rotor salient poles 12a near the U-phase salient pole is attracted to the U-phase salient pole to give a torque to the rotor 10.

[0073] Here, referring to FIG. 7 again, in the angular zone 0 illustrated in FIG. 7, terms “U-unopposed” and “V-opposed” are described. The “U-unopposed” means that the U-phase salient pole is not opposed to the rotor salient pole. In other words, in the “U-unopposed”, the U-phase salient pole is opposed to an intermediate portion of the two adjacent rotor salient poles 12. In this example, when the rotor position is 15 degrees, “U-unopposed” is generated. The “V-opposed” means that the V-phase salient pole is opposed to the rotor salient pole. In this example, as illustrated in FIG. 8D, when the rotor position is 45 degrees, the “V-opposed” is generated. For example, terms “V-unopposed” and “U-opposed” are also described in other angular zones 1 to 5 illustrated in FIG. 7, and have similar meanings.

[0074] Next, referring to FIG. 8E, FIG. 8E schematically illustrates the excitation state at the rotor position of 60 degrees (the boundary between the angular zone 0 and the angular zone 1). A current “+1” remains to pass through the coil around the U-phase salient pole, but a current passing through the coil around the V-phase salient pole stops. Then, a current “-1” starts to pass through the coil around the W-phase salient pole. At the position illustrated in FIG. 8E, the rotor salient pole 12a near the U-phase salient pole is attracted to the U-phase salient pole to give a torque to the rotor 10.

[0075] Next, referring to FIG. 8F, FIG. 8F schematically illustrates the excitation state at the rotor position of 75 degrees (angular zone 1). Currents passing through the coil around the U-phase salient pole and the coil around the W-phase salient pole are the same as those in FIG. 8E. At the position illustrated in FIG. 8F, the W-phase salient pole is opposed to an intermediate position of the two adjacent rotor salient poles (W-unopposed). The rotor salient poles 12a near the U-phase salient pole is attracted to the U-phase salient pole to give a torque to the rotor 10.

[0076] Next, referring to FIG. 8G, FIG. 8G schematically illustrates the excitation state at the rotor position of 90 degrees (angular zone 1). Currents passing through the coil around the U-phase salient pole and the coil around the W-phase salient pole are the same as those in the excitation state illustrated in FIG. 8F. The rotor salient poles 12a near

the U-phase salient pole is attracted to the U-phase salient pole, and the rotor salient poles **12b** near the W-phase salient pole is attracted to the W-phase salient pole to give a torque to the rotor **10**.

[0077] Next, referring to FIG. **8H**, FIG. **8H** schematically illustrates the excitation state at the rotor position of 105 degrees (angular zone **1**). Currents passing through the coil around the U-phase salient pole and the coil around the W-phase salient pole are the same as those in the excitation state illustrated in FIG. **8G**. However, since the U-phase salient pole is opposed to the rotor salient pole **12a**, a torque is not given to the rotor salient poles **12a**. The rotor salient poles **12b** near the W-phase salient pole is attracted to the W-phase salient pole to give a torque to the rotor **10**.

[0078] Finally, referring to FIG. **8I**, FIG. **8I** schematically illustrates the excitation state at the rotor position of 120 degrees (the boundary between the angular zone **1** and the angular zone **2**). A current passing through the coil around the U-phase salient pole stops and instead, a current “+1” starts to pass through the coil around the V-phase salient pole. A current passing through the coil around the W-phase salient pole does not change. The rotor salient poles **12b** near the W-phase salient pole is attracted to the W-phase salient pole to give a torque to the rotor **10**.

[0079] The rotor position illustrated in FIG. **8I** may be detected based on the second magnetic sensor **60V** in FIG. **5** being opposed to the boundary position between the S pole and the N pole in the sensor magnet **50**.

[0080] As described above, the period during which the current passes through the coil around the U-phase salient pole to excite the U-phase salient pole is the period during which the rotor position becomes 0 degrees to 120 degrees. In other words, the rotor position (reference position Ref) where the current starts to pass through the coil around the U-phase salient pole is the position reversely rotated from the position where the U-phase salient pole is opposed to any of the plurality of rotor salient poles **12** by 105 degrees in the electrical angle. The boundary position between the S pole and the N pole in the sensor magnet **50** attached to the shaft **40** is determined such that the first magnetic sensor **60U** may detect that the rotor position has reached the reference position Ref. Specifically, when the circumferential center of at least one rotor salient pole **12** among the plurality of rotor salient poles **12** aligns with the circumferential center of the U-phase salient pole, the boundary position between the S pole and the N pole in the sensor magnet **50** is assumed to be about 15 degrees in the electrical angle (7.5 degrees in the mechanical angle) reversely rotated from the position opposed to the second magnetic sensor **60V** in the circumferential direction of the shaft **40**. Desirably, the boundary position between the S pole and the N pole in the sensor magnet **50** falls within the range from 10 to degrees in the electrical angle (5 to 10 degrees in the mechanical angle) reversely rotated from the position opposed to the second magnetic sensor **60V** in the circumferential direction of the shaft **40**. The range from 10 to 20 degrees in the electrical angle assumes ± 5 degrees in the electrical angle as a mounting error.

[0081] Referring to FIGS. **8A** to **8I**, the movement of the rotor **10** in the period (120 degrees in the electrical angle) during which the U-phase salient pole is excited has been mainly described. The periods during which V and W-phase stator salient poles are excited may be recognized in the similar manner. The driving mode of exciting each of the

U-phase, V-phase, and W-phase salient poles by 120 degrees in the electrical angle may be referred to as “120-degree conduction”. In the present example embodiment, 360 degrees in the electrical angle is divided into the six angular zone, and the excitation state is switched in six steps (6-step driving). Since the excitation state is switched in six steps according to the rotor position, even when the rotor position is located in any of the angular zones, a torque to normally rotate the rotor **10** is generated at all times.

[0082] FIG. **9** is a graph illustrating the relation between the magnitude of the torque generated in the rotor **10** and the rotor position in the present example embodiment. The magnitude of the torque was calculated. The graph in FIG. **9** illustrates a curve indicating the torque generated by the U-phase salient pole, a curve indicating the torque generated by the V-phase salient pole, a curve indicating the torque generated by the W-phase salient pole, and a curve indicating the total torque.

[0083] FIGS. **10A**, **10B**, and **10C** are a graph illustrating a curve indicating the torque generated by the U-phase salient pole, a graph illustrating a curve indicating the torque generated by the V-phase salient pole, and a graph illustrating a curve indicating the torque generated by the W-phase salient pole, respectively. As apparent to these drawings, according to the rotor position, the torque generated by one of the excited 2-phase stator salient poles may be negative. For example, when the rotor position falls within the range from 0 to 15 degrees, the torque generated by the U-phase salient pole is negative as illustrated in FIG. **10A**, while the torque generated by the V-phase salient pole has a sufficiently large positive value as illustrated in FIG. **10B**. When the rotor position falls within the range from 45 to 60 degrees, the torque generated by the V-phase salient pole is negative as illustrated in FIG. **10B**, while the torque generated by the U-phase salient pole has a sufficiently large positive value as illustrated in FIG. **10A**. As described above, even when part of the torque generated by the U-phase salient pole, the V-phase salient pole, and the W-phase salient pole is negative, the total torque is positive at all times as illustrated in FIG. **9**. Accordingly, wherever the rotor **10** is stopped before rotation in any of locations, by detecting the angular zone, in which the rotor position is located, among the six angular zones **0** to **6**, the rotor **10** may be started in the normal rotation. Since the angular resolution to detect the rotor position is 60 degrees in the electrical angle, an expensive angular sensor such as a resolver or rotary encoder having higher resolution is unnecessary.

[0084] The excitation pattern illustrated in FIG. **7** is performed at the start of rotation of the SR motor **100**. After the start of rotation of the rotor **10**, driving for achieving another excitation pattern may be performed in accordance with the rotational speed of the rotor **10**. For example, at timing shifted from the time when the level of the output signal of the first magnetic sensor **60U** changes from Low to High by predetermined dimension, excitation of the U-phase salient pole may be started. The period during a current passes through each of the coils **30** around the U-phase salient pole, the V-phase salient pole, and the W-phase salient pole is not limited to “120-degree conduction”, and may be changed in accordance with the rotational speed of the rotor **10** or so on.

[0085] In the example embodiment of the present disclosure, when viewed from the magnetic sensor side, the clockwise rotational direction of the rotor is defined as “normal rotation”. Since “normal rotation” and “reverse

rotation” are diametrically opposed to each other, even if the definitions of “normal rotation” and “reverse rotation” are interchanged, the effect of the present disclosure may be apparently acquired. As a result of such interchange, the configuration illustrated in FIG. 1A is horizontally reversed, and counterclockwise rotation in FIG. 1A agrees with “normal rotation”.

[0086] The reluctance motor of the present disclosure is not limited to the switched reluctance motor in the above-mentioned example embodiment, and may be a synchronous reluctance motor. The structure of the reluctance motor of the present disclosure is not limited to the “6-4 structure”, and may be, for example, the “3-2 structure” and the “6-2 structure”.

[0087] FIG. 11 is a circuit diagram of a motor system according to a non-limiting exemplary example embodiment of the present disclosure.

[0088] A motor system 1000 illustrated in FIG. 11 includes the above-mentioned SR motor 100, an inverter circuit 200 electrically connected to the 3-phase (U, V, and W phases) coils of the SR motor 100, and a motor control circuit 300 electrically connected to the inverter circuit 200.

[0089] The motor control circuit 300 receives outputs of the magnetic sensors 60, and outputs a drive signal (gate control signal) to change the voltage applied to the 3-phase coils while the rotor position rotates by 360 degrees in the electrical angle in accordance with an angular zone which is one of the six angular zones acquired by equally dividing 360 degrees in the electrical angle in FIG. 5 and in which the rotor is located. In response to the drive signal, the inverter circuit 200 passes a current through 2-phase coils sequentially selected from the 3-phase coils to excite each-phase stator salient pole at a predetermined timing. Particularly at the start of the motor, the motor control circuit 300 in the present example embodiment inputs to the inverter circuit 200 the drive signal for achieving the excitation pattern illustrated in FIG. 7.

[0090] The inverter circuit 200 illustrated in FIG. 11 is a general-purpose inverter circuit including a full-bridge inverter, and is connected to a DC power source 400 in use. The DC power source 400 may include a converter circuit (not illustrated) for converting a commercial AC voltage into a DC voltage.

[0091] The inverter circuit 200 in FIG. 11 includes switching elements HS₁, HS₂, HS₃, LS₁, LS₂, and LS₃. The switching elements HS₁, HS₂, HS₃, LS₁, LS₂, and LS₃ each may be a MOS electric field transistor (MOSFET) including a reflux diode, or a MOSFET connected in parallel to a reflux diode element. In place of the MOSFET, an insulated gate bipolar transistor (IGBT) may be used. These switching elements HS₁, HS₂, HS₃, LS₁, LS₂, and LS₃ constitute a 3-phase full-bridge circuit. A gate electrode (gate terminal) of each of the switching elements HS₁, HS₂, HS₃, LS₁, LS₂, and LS₃ is connected to the motor control circuit 300.

[0092] Describing in more detail, the switching elements HS₁ and LS₁ are connected to each other in series via a first node N1 between a high-side line PL connected to the positive side of the DC power source 400 and a low-side line NL connected to the negative side. The first node N1 is connected to one end of the coil around the U-phase salient pole in the SR motor 100. The switching elements HS₂ and LS₂ are connected to each other in series via a second node N2 between the high-side line PL and the low-side line NL. The second node N2 is connected to one end of the coil

around the V-phase salient pole in the SR motor 100. The switching elements HS₃ and LS₃ are connected to each other in series via a third node N3 between the high-side line PL and the low-side line NL. The third node N3 is connected to one end of the coil around the W-phase salient pole in the SR motor 100.

[0093] In this example, the coil around the U-phase salient pole, the coil around the V-phase salient pole, and the coil around the W-phase salient pole are connected by a wye connection or a delta connection. Thus, for example, when a current passes through the coil around the U-phase salient pole, the current preferably returns through at least one of the coil around the V-phase salient pole and the coil around the W-phase salient pole. By using the inverter circuit 200 including such 3-phase full-bridge circuit, driving may be performed in accordance with the excitation pattern illustrated in FIG. 7.

[0094] FIG. 12 is a circuit diagram illustrating another inverter circuit 200A including the 3-phase full-bridge circuit. The inverter circuit 200A illustrated in FIG. 12 includes switching elements S₁, S₂, S₃, S₄, S₅, and S₆ and diodes D₁, D₂, D₃, D₄, D₅, and D₆. The switching elements S₁, S₂, S₃, S₄, S₅, and S₆ each are typically, a MOSFET or an IGBT. The switching elements HS₁, HS₂, HS₃, LS₁, LS₂, and LS₃ and the diodes D₁, D₂, D₃, D₄, D₅, and D₆ constitute a 3-phase full-bridge circuit. A gate electrode of each of the switching elements S₁, S₂, S₃, S₄, S₅, and S₆ is connected to the motor control circuit 300.

[0095] Describing in more detail, the switching elements S₁ and S₂ are connected to each other in series via a first node N1a between a high-side line PL and a low-side line NL. The diodes D₁ and D₂ are connected to each other in series via a second node N1b between the high-side line PL and the low-side line NL. Both of the first node N1a and the second node N1b are connected to one end of the coil around the U-phase salient pole in the SR motor 100. The switching elements S₃ and S₄ are connected to each other in series via a third node N2a between the high-side line PL and the low-side line NL. The diodes D₃ and D₄ are connected to each other in series via a fourth node N2b between the high-side line PL and the low-side line NL. Both the third node N2a and the fourth node N2b are connected to one end of the coil around the V-phase salient pole in the SR motor 100. The switching elements S₅ and S₆ are connected to each other in series via a fifth node N3a between the high-side line PL and the low-side line NL. The diodes D₅ and the D₆ are connected to each other in series via a sixth node N3b between the high-side line PL and the low-side line NL. Both of the fifth node N3a and the sixth node N3b are connected to one end of the coil around the W-phase salient pole in the SR motor 100.

[0096] The inverter circuit 200A illustrated in FIG. 12 may achieve driving according to the excitation pattern illustrated in FIG. 7. Also in this example, the coil around the U-phase salient pole, the coil around the V-phase salient pole, and the coil around the W-phase salient pole are connected by a wye connection or a delta connection.

[0097] Next, referring to FIG. 13, the configuration of an inverter circuit 200B including an asymmetric half-bridge inverter. When the inverter circuit 200B is used, the coil around the U-phase salient pole, the coil around the V-phase salient pole, and the coil around the W-phase salient pole are not interconnected, and currents passing through respective coils may be independently controlled.

[0098] The inverter circuit **200B** illustrated in FIG. **13** includes switching elements $S_1, S_2, S_3, S_4, S_5,$ and S_6 and diodes $D_1, D_2, D_3, D_4, D_5,$ and D_6 . The switching elements $S_1, S_2, S_3, S_4, S_5,$ and S_6 and the diodes $D_1, D_2, D_3, D_4, D_5,$ and D_6 constitute a 3-phase half-bridge circuit. A gate electrode of each of the switching elements $S_1, S_2, S_3, S_4, S_5,$ and S_6 is connected to the motor control circuit **300**.

[0099] Describing in more detail, the switching element S_1 and the diode D_1 are connected to each other in series via a first node $N1a$ between a high-side line PL and a low-side line NL. The diode D_2 and the switching element S_2 are connected to each other in series via a second node $N1b$ between the high-side line PL and the low-side line NL. The first node $N1a$ and the second node $N1b$ are connected to both respective ends of the coil around the U-phase salient pole in the SR motor **100**. The switching element S_3 and the diode D_3 are connected to each other in series via a third node $N2a$ between the high-side line PL and the low-side line NL. The diode D_4 and the switching element S_4 are connected to each other in series via a fourth node $N2b$ between the high-side line PL and the low-side line NL. Both of the third node $N2a$ and the fourth node $N2b$ are connected to both respective ends of the coil around the V-phase salient pole in the SR motor **100**. The switching element S_5 and the diode D_5 are connected to each other in series via a fifth node $N3a$ between the high-side line PL and the low-side line NL. The diode D_6 and the switching element S_6 are connected to each other in series via a sixth node $N3b$ between the high-side line PL and the low-side line NL. Both of the fifth node $N3a$ and the sixth node $N3b$ are connected to both respective ends of the coil around the W-phase salient pole in the SR motor **100**.

[0100] When the inverter circuit **200B** illustrated in FIG. **13** is used, currents independently pass through the coil around the U-phase salient pole, the coil around the V-phase salient pole, and the coil around the W-phase salient pole in one direction. Thus, as illustrated in FIG. **14**, the excitation state of the U-phase salient pole, the V-phase salient pole, and the W-phase salient pole may be represented as “+1” or “0”. If the salient poles are connected such that the currents pass in opposite directions, the excitation state may be represented as “-1” or “0”.

[0101] As described above, in the reluctance motor, the orientation of the current passing through the coil in the stator **20** does not affect a torque. Thus, the inverter circuit may have three asymmetric half-bridge inverters, or may have a 3-phase full-bridge inverter.

[0102] FIG. **15** is a circuit diagram of an inverter circuit **200D** including two 3-phase full-bridge inverters **200C**. The two 3-phase full-bridge inverters **200C** each have the same configuration as the inverter circuit **200A** in FIG. **12**. The inverter circuits **200D** may operate in the similar manner as the inverter circuit **200B** in FIG. **13**.

[0103] FIG. **16** illustrates an example of the hardware configuration of the motor control circuit **300**. The motor control circuit **300** in this example has a central processing unit (CPU) **320**, a PWM circuit **330**, a read only memory (ROM) **340**, a random access memory (RAM) **350**, and an input/output interface (I/F) **360**, which are interconnected via a bus. Another circuit or device (AD converter or the like) may be additionally connected to the bus. The PWM circuit **330** sends a drive signal to the inverter circuit **200**. The drive signal is inputted to a gate terminal of each switching element in the inverter circuit **200** to control

ON/OFF of each switching elements. A program and data that define the operation of the CPU **320** are stored in at least one of the ROM **340** and RAM **350**. Such motor control circuit **300** may be embodied as, for example, a general-purpose 32-bit microcontroller. The microcontroller may be formed of one or more integrated circuit chips.

[0104] Various operations of the motor control circuit **300** are defined by the program. According to the program, at the start of the motor, a drive signal for achieving the excitation pattern in FIG. **7** is generated and inputted to a gate terminal of each switching element in the inverter circuit **200**. A drive signal generated after the start may be generated to achieve the well-known driving method according to the rotational speed and thus, details thereof are omitted. By updating a part or whole of contents of the program, a part or whole of the operations of the motor control circuit **300** may be changed. The program may be updated using a recording medium that stores the program, or via wired or wireless communication. The communication may be made using the I/F **360** illustrated in FIG. **16**. The configuration of the motor control circuit **300** is not limited to the configuration illustrated in FIG. **16**.

[0105] As apparent from the above-mentioned description, the reluctance motor and the motor system according to the example embodiment of the present disclosure may activate the rotor by effectively utilizing the rotor position sensing technology using the magnetic sensor such as Hall IC, and the full-bridge inverter, which have been widely adopted in the permanent magnet-typed motor.

[0106] The reluctance motor and the motor system of the present disclosure may be used in various machines, apparatuses, and drive sources for mobile body to convert electric power into mechanical energy.

[0107] Features of the above-described example embodiments and the modifications thereof may be combined appropriately as long as no conflict arises.

[0108] While example embodiments of the present disclosure have been described above, it is to be understood that variations and modifications will be apparent to those skilled in the art without departing from the scope and spirit of the present disclosure. The scope of the present disclosure, therefore, is to be determined solely by the following claims.

1-11. (canceled)

12. A reluctance motor comprising:

a rotor including N rotor salient poles where N is an integer of 2 or more;

a stator including M stator salient poles where M is an integer of 3 or more;

3-phase coils to excite the stator salient poles;

a shaft rotatably connected to the rotor;

a sensor magnet fixed to an outer circumference of the shaft, the sensor magnet including an S pole and an N pole alternately arranged in a circumferential direction of the shaft; and

three magnetic sensors opposed to the sensor magnet; wherein

a number of poles of the sensor magnet is N.

13. The reluctance motor according to claim **12**, wherein N is four, and M is six.

14. The reluctance motor according to claim **12**, wherein the 3-phase coils are U-phase, V-phase, and W-phase coils, and each of n and m is an integer;

the three magnetic sensors include:

a first magnetic sensor disposed at a first position;

- a second magnetic sensor disposed at a second position rotated from the first position in the circumferential direction of the shaft by about 120 degrees+about 360 degrees×n; and
- a third magnetic sensor disposed at a third position rotated from the first position in the circumferential direction of the shaft by about 240 degrees+about 360 degrees×n;
- when a center in a circumferential direction of at least one of the rotor salient poles aligns with a center in a circumferential direction of the stator salient pole including the U-phase coil among the stator salient poles, a boundary position between the S pole and the N pole of the sensor magnet is reversely rotated from a position opposed to the second magnetic sensor by an electrical angle of about 10 degrees to about 20 degrees in the circumferential direction of the shaft.
- 15.** The reluctance motor according to claim **12**, wherein the three magnetic sensors are three Hall ICs located at intervals of about 120 degrees in a mechanical angle.
- 16.** The reluctance motor according to claim **12**, wherein the 3-phase coils are connected by a wye connection or a delta connection.
- 17.** The reluctance motor according to claim **12**, wherein the 3-phase coils are electrically isolated from one another.
- 18.** A motor system comprising:
the reluctance motor according to claim **12**;
an inverter circuit electrically connected to the 3-phase coils of the reluctance motor; and
- a motor control circuit electrically connected to the inverter circuit; wherein
- the motor control circuit receives outputs of the magnetic sensors, and outputs a drive signal to switch a voltage applied to the 3-phase coils while the rotor rotates by 360 degrees in an electrical angle, in accordance with a zone which is one of six angular zones and in which the rotor is located, the six angular zones being acquired by equally dividing 360 degrees in the electrical angle; and
- the inverter circuit applies the voltage to the 3-phase coils according to the drive signal.
- 19.** The motor system according to claim **18**, wherein when the rotor is rotated in a first direction, the motor control circuit outputs the drive signal to apply 120-degree conduction to the 3-phase coils.
- 20.** The motor system according to claim **19**, wherein in response to the drive signal, the inverter circuit passes a current to 2-phase coils sequentially selected from the 3-phase coils.
- 21.** The motor system according to claim **20**, wherein the inverter circuit includes three asymmetric half-bridge inverters connected to the respective 3-phase coils.
- 22.** The motor system according to claim **20**, wherein the inverter circuit includes at least one 3-phase full-bridge inverter connected to the 3-phase coils.

* * * * *