



US 20160186971A1

(19) **United States**

(12) **Patent Application Publication**  
Selevan et al.

(10) **Pub. No.: US 2016/0186971 A1**

(43) **Pub. Date: Jun. 30, 2016**

(54) **SEQUENTIAL AND COORDINATED  
FLASHING OF ELECTRONIC ROADSIDE  
FLARES WITH ACTIVE ENERGY  
CONSERVATION**

*F21L 4/02* (2006.01)  
*F21V 23/00* (2006.01)  
*H05B 33/08* (2006.01)  
*F21V 33/00* (2006.01)

(71) Applicants: **Daniel Joseph Selevan**, Laguna Beach, CA (US); **James R. Selevan**, Laguna Beach, CA (US)

(52) **U.S. Cl.**  
CPC ..... *F21V 23/0407* (2013.01); *H05B 33/0845* (2013.01); *F21V 33/0076* (2013.01); *F21L 4/02* (2013.01); *F21V 23/003* (2013.01); *F21V 23/0471* (2013.01); *H05B 37/0272* (2013.01); *F21W 2111/02* (2013.01)

(72) Inventors: **James R. Selevan**, Laguna Beach, CA (US); **Daniel Selevan**, Laguna Beach, CA (US)

(21) Appl. No.: **14/941,646**

(57) **ABSTRACT**

(22) Filed: **Nov. 15, 2015**

Electronic light emitting flares and related methods. Flares of the present invention include various features such as self-synchronization, remote control, motion-actuated or percussion-actuated features, dynamic shifting between side-emitting and top-emitting light emitters in response to changes in positional orientation (e.g., vertical vs. horizontal) of the flare; overrides to cause continued emission from side-emitting or top-emitting light emitters irrespective of changes in the flare's positional orientation; use of the flare(s) for illumination of traffic cones and other hazard marking or traffic safety objects or devices, group on/off features, frequency specificity to facilitate use of separate groups of flares in proximity to one another, selection and changing of flashing patterns and others.

**Related U.S. Application Data**

(63) Continuation-in-part of application No. 29/525,453, filed on Apr. 29, 2015.

(60) Provisional application No. 62/080,294, filed on Nov. 15, 2014.

**Publication Classification**

(51) **Int. Cl.**  
*F21V 23/04* (2006.01)  
*H05B 37/02* (2006.01)

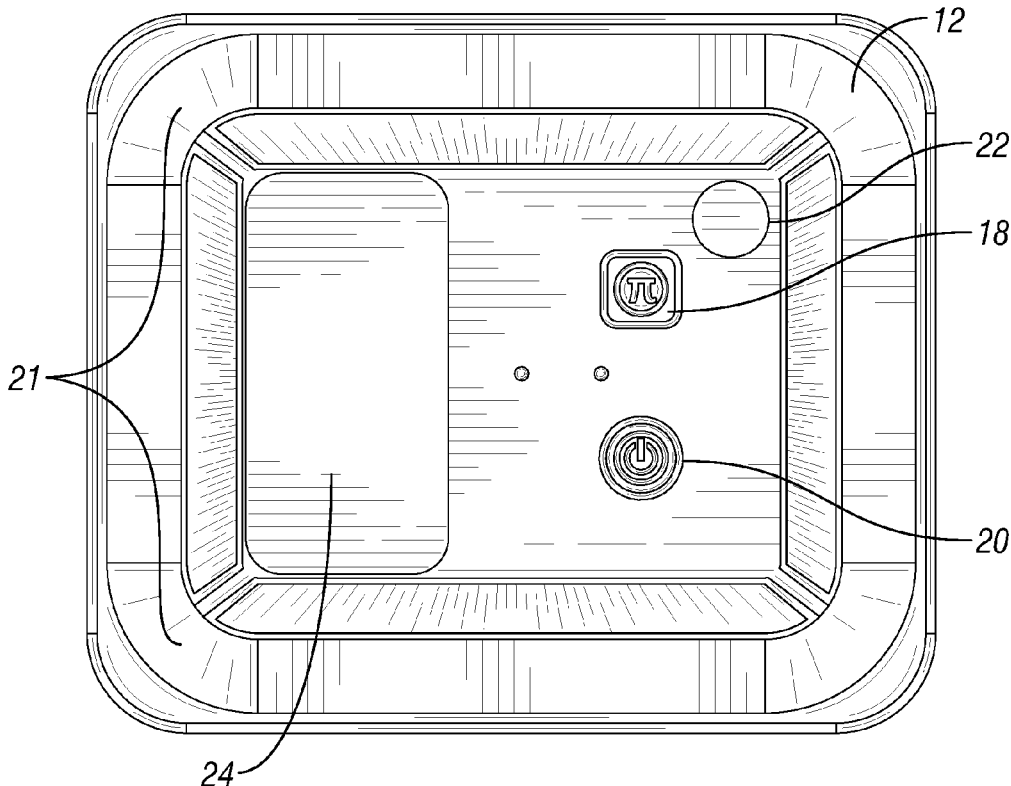

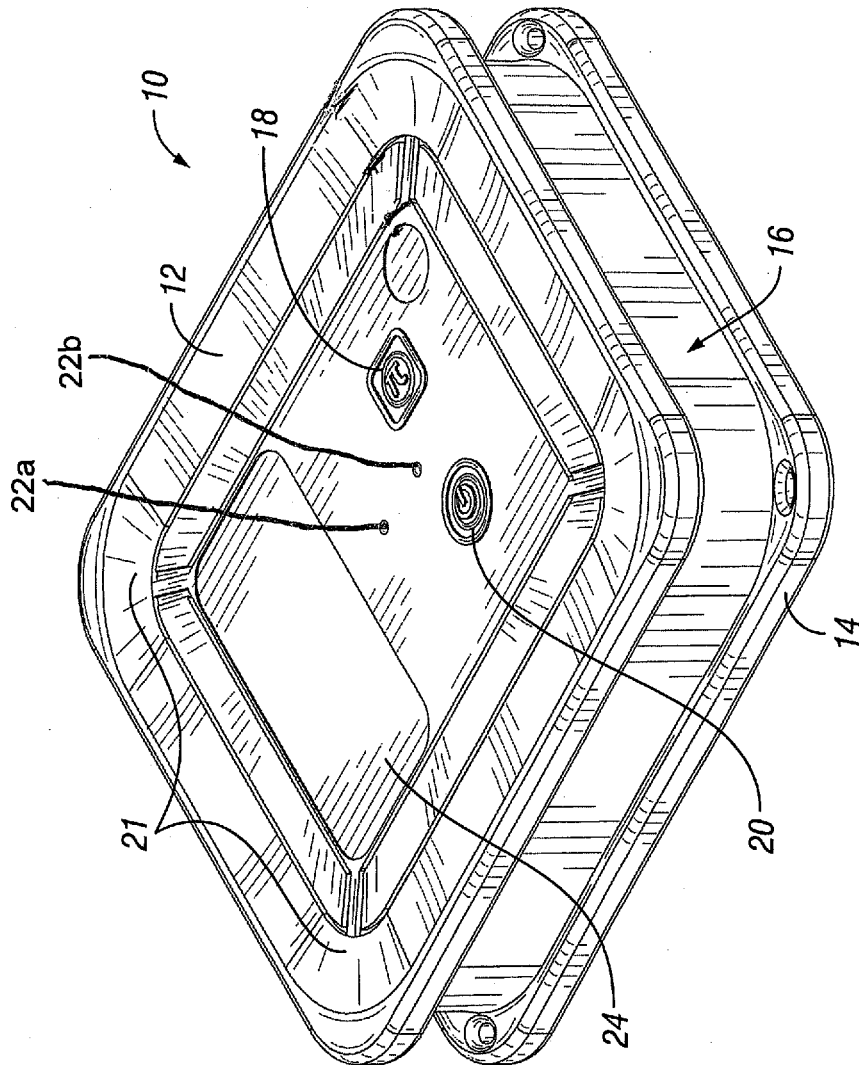

FIG. 1

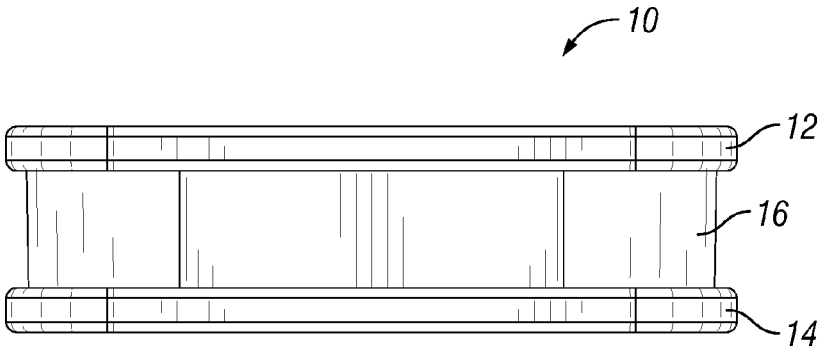

FIG. 2

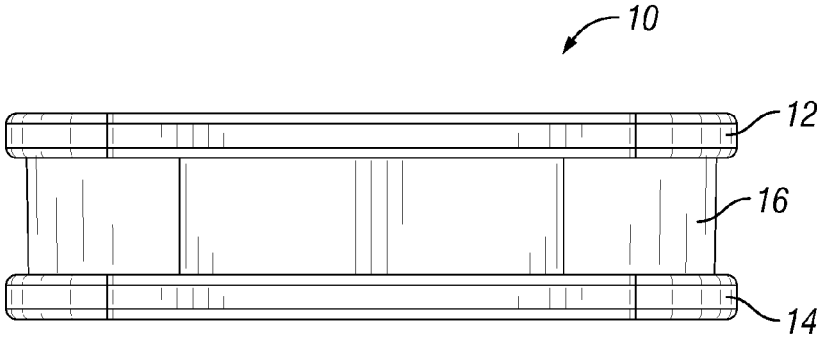

FIG. 3

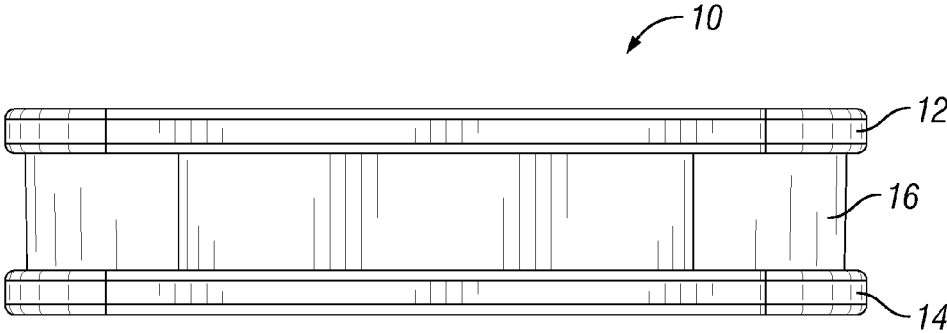

FIG. 4

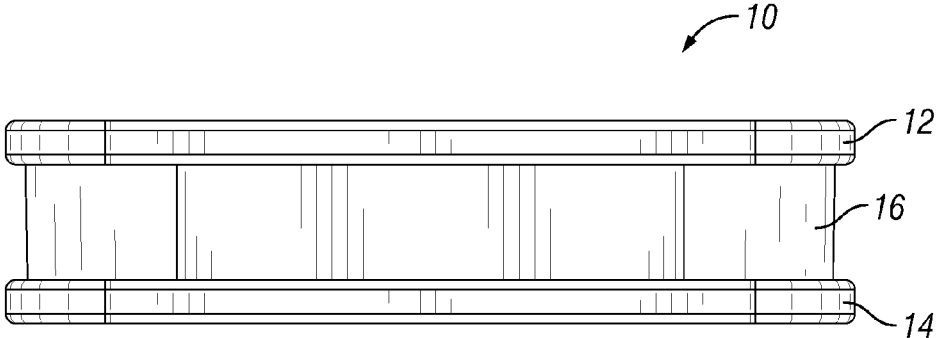

FIG. 5

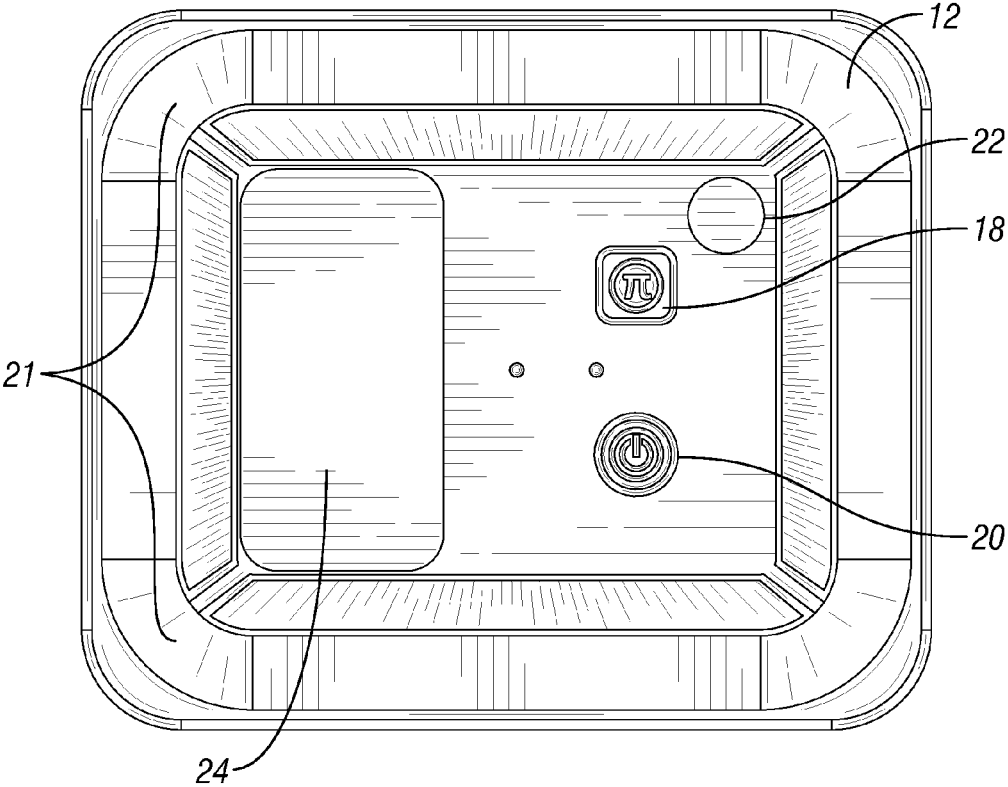

FIG. 6

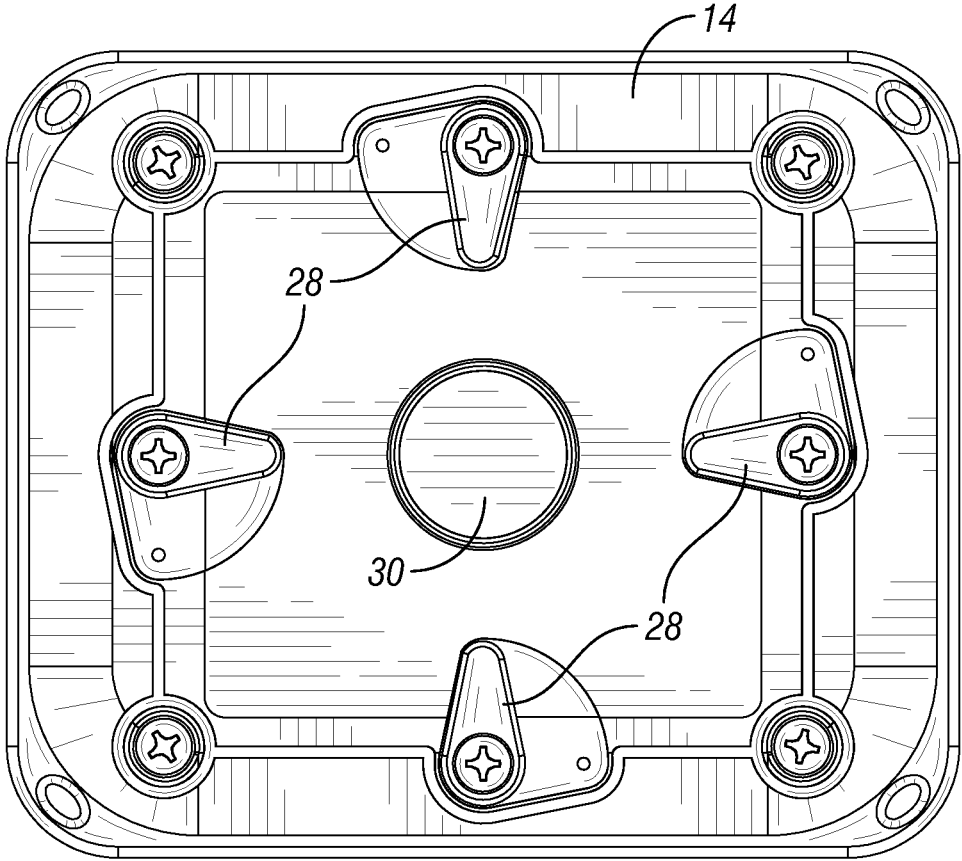

FIG. 7

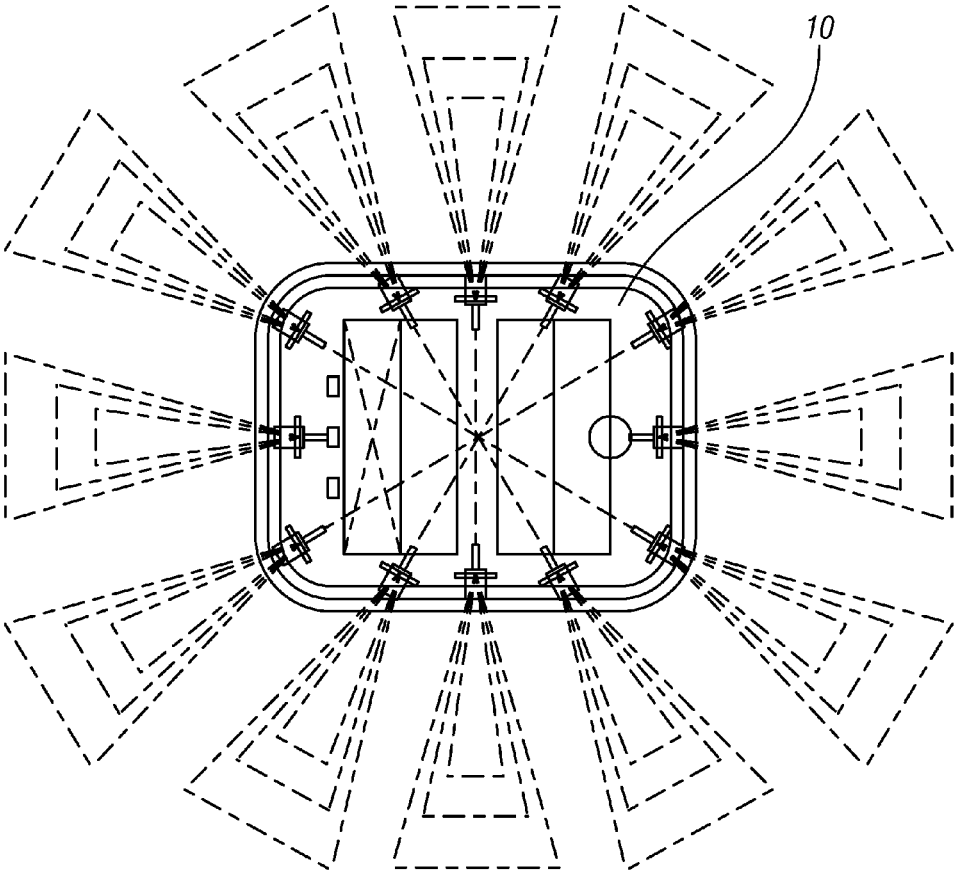

FIG. 8

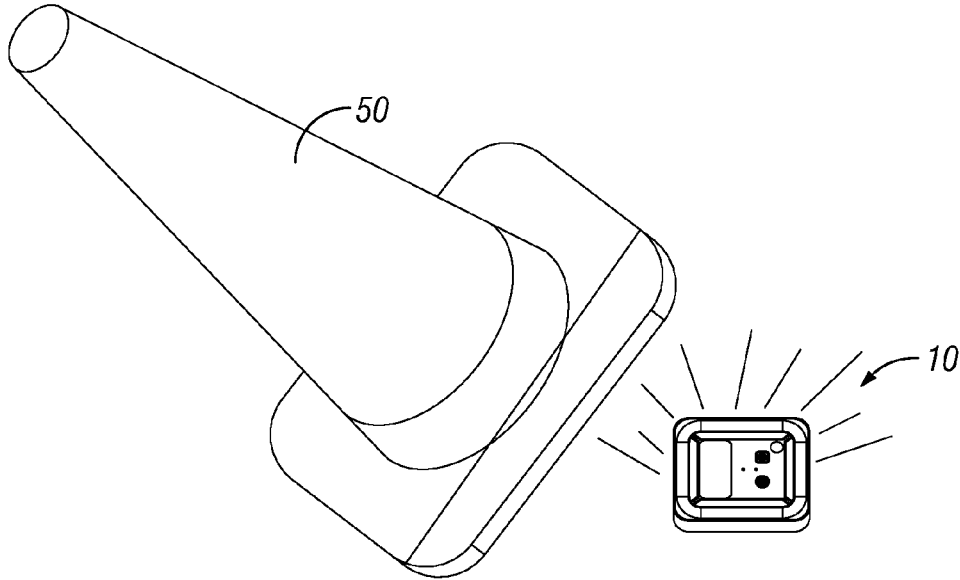

FIG. 9A

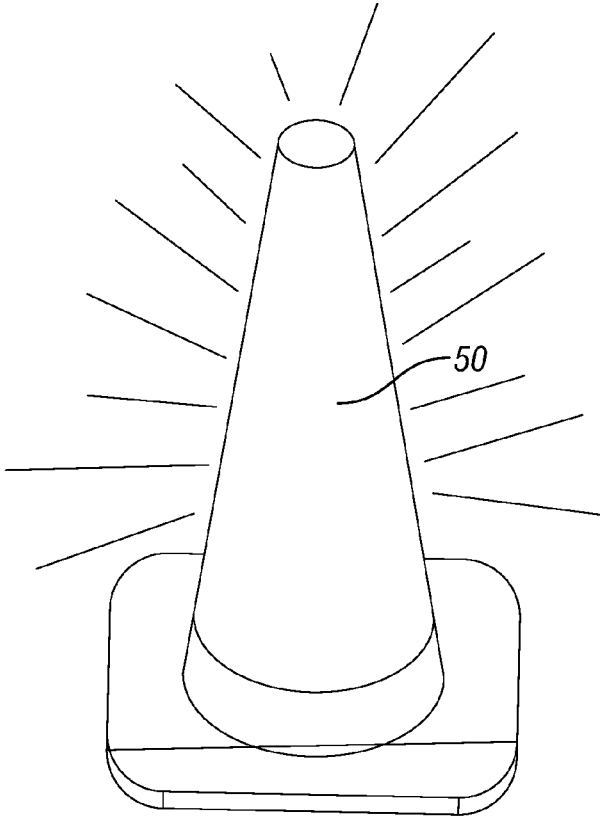

FIG. 9B

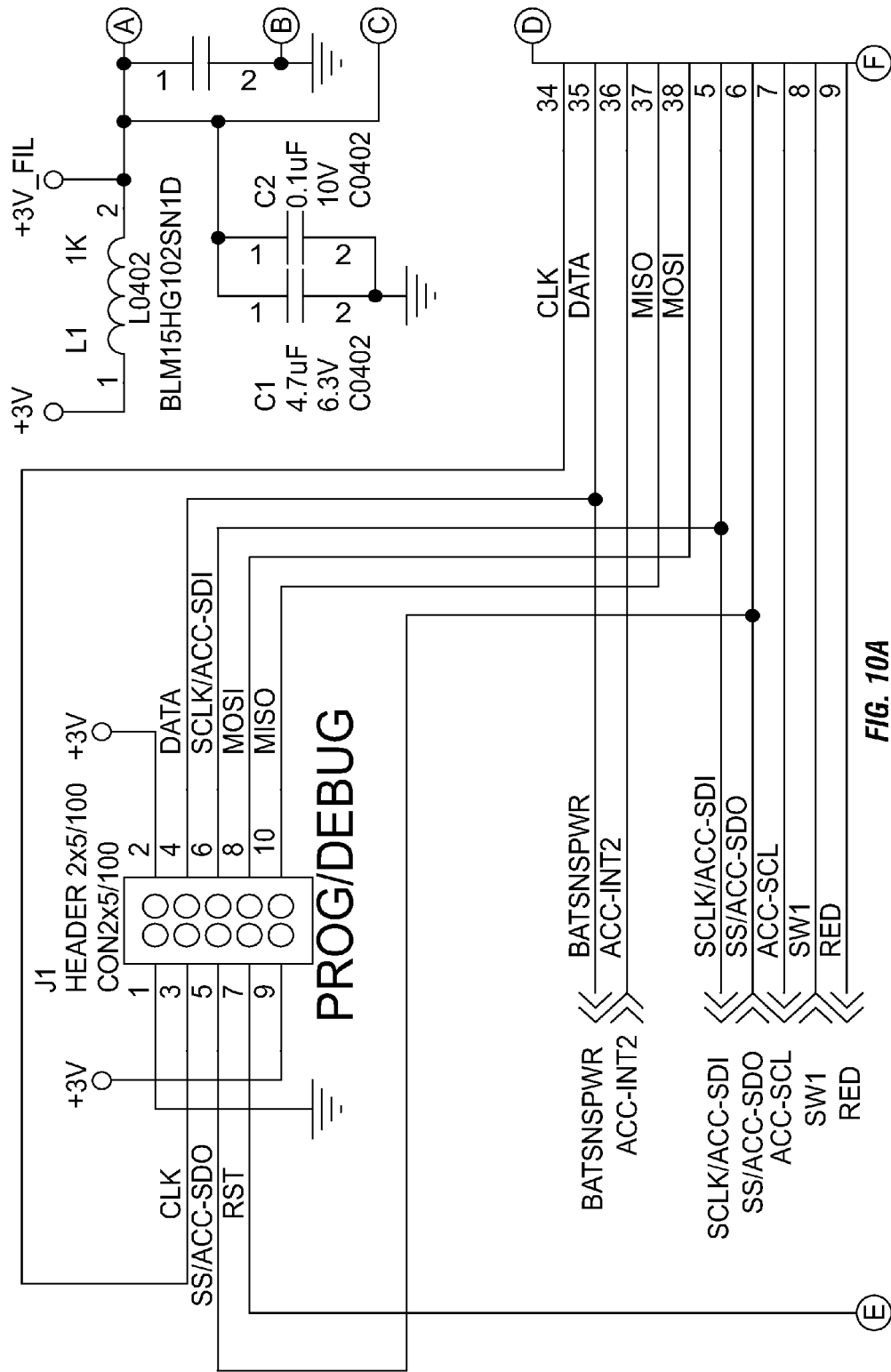

FIG. 10A



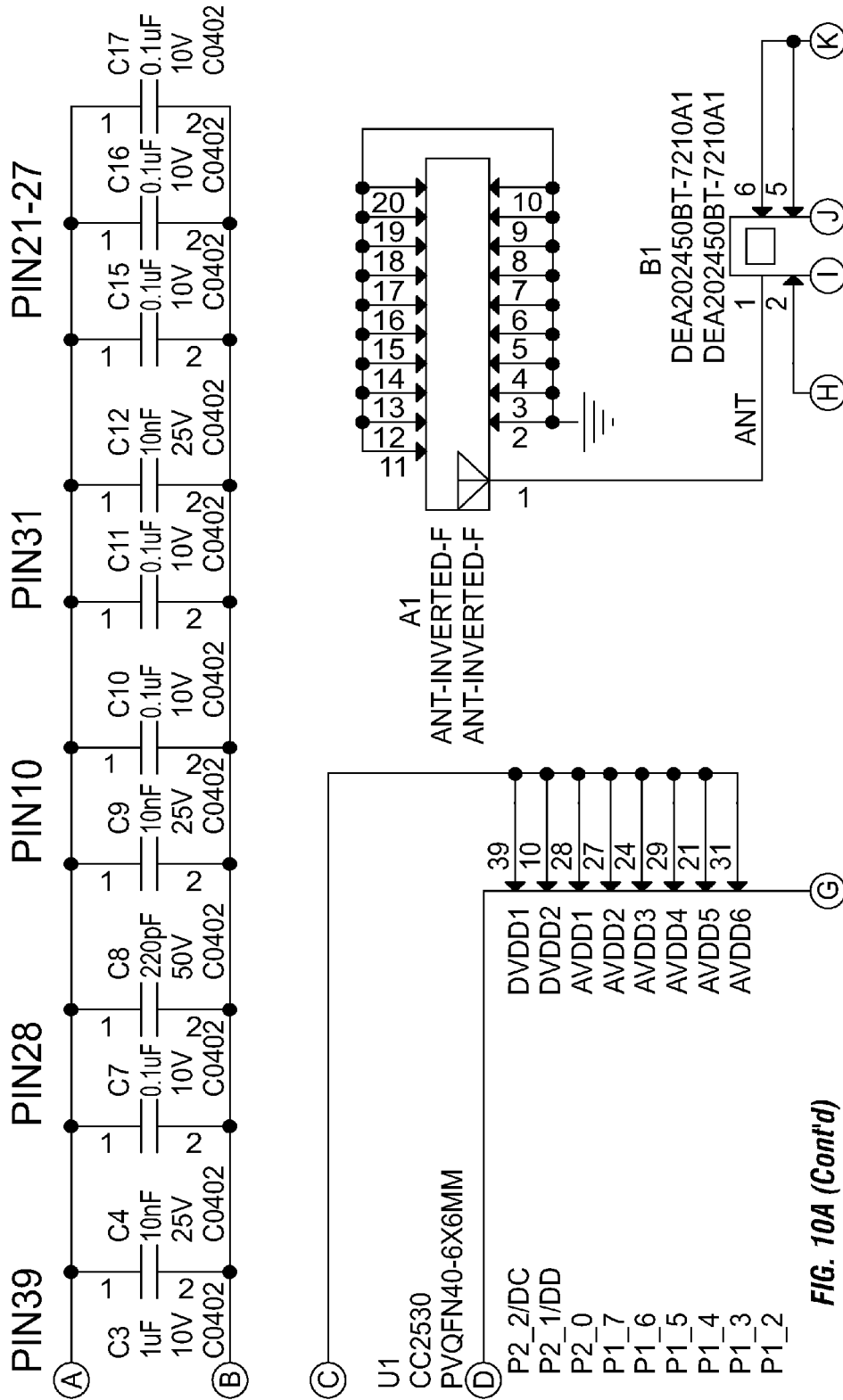

FIG. 10A (Cont'd)

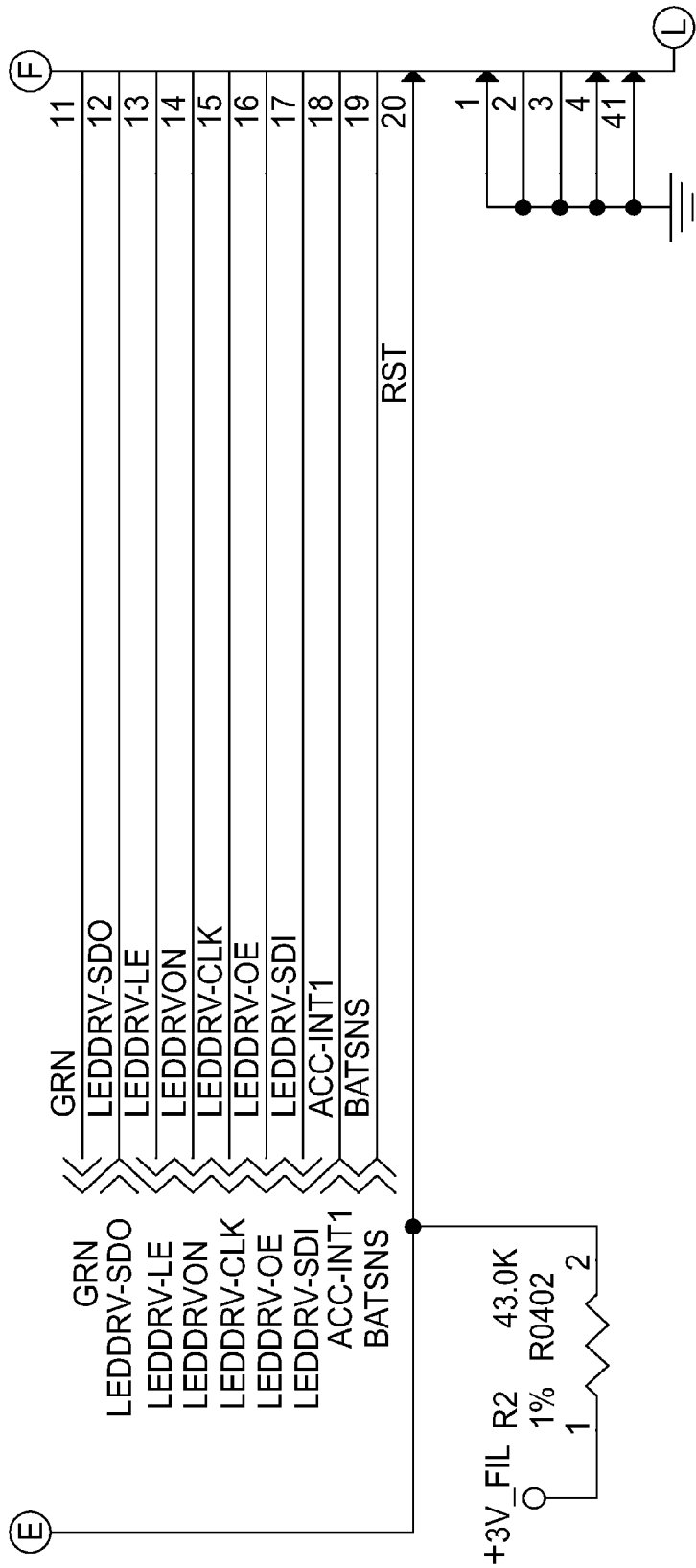

FIG. 10A (Cont'd)

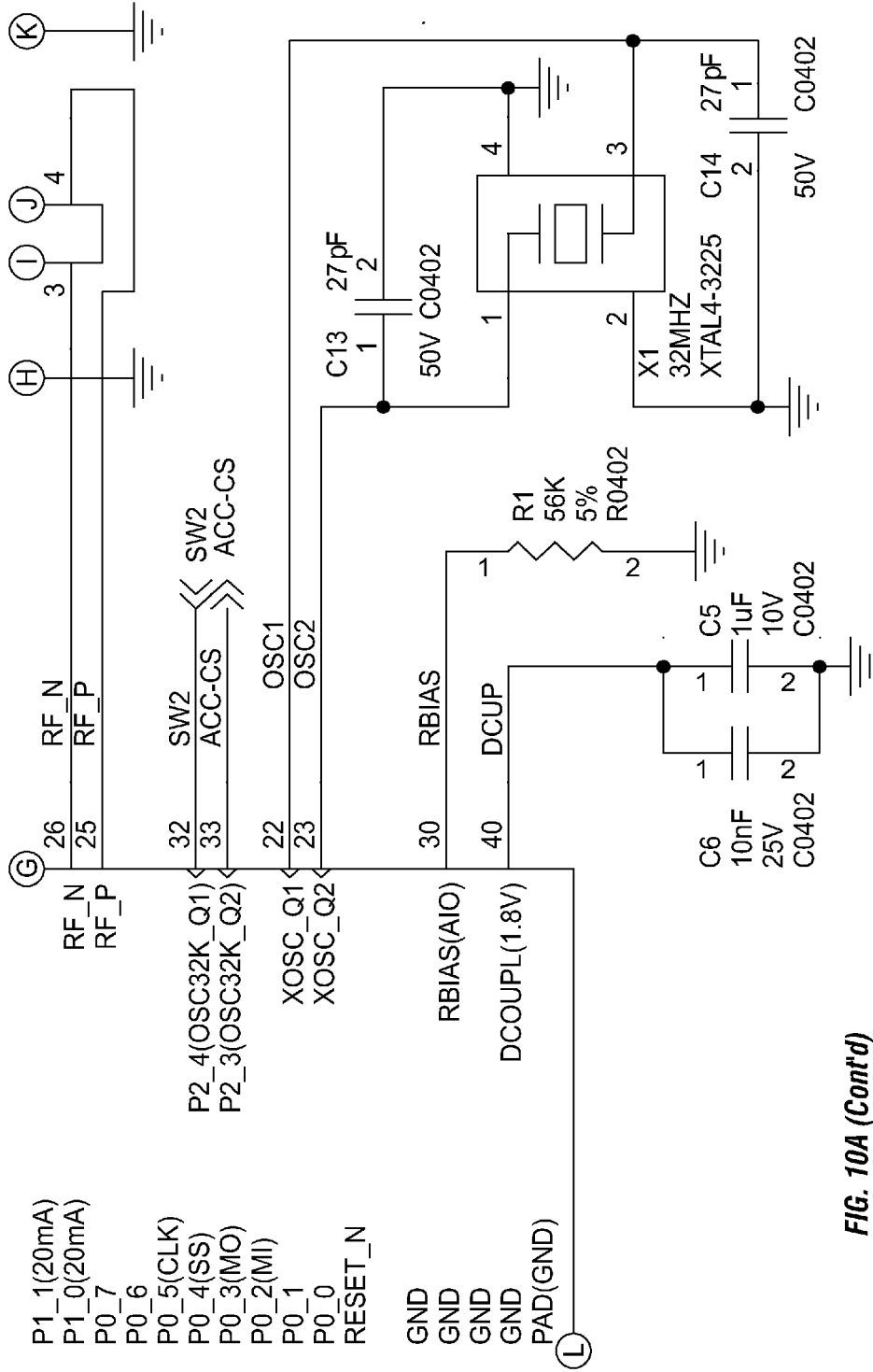
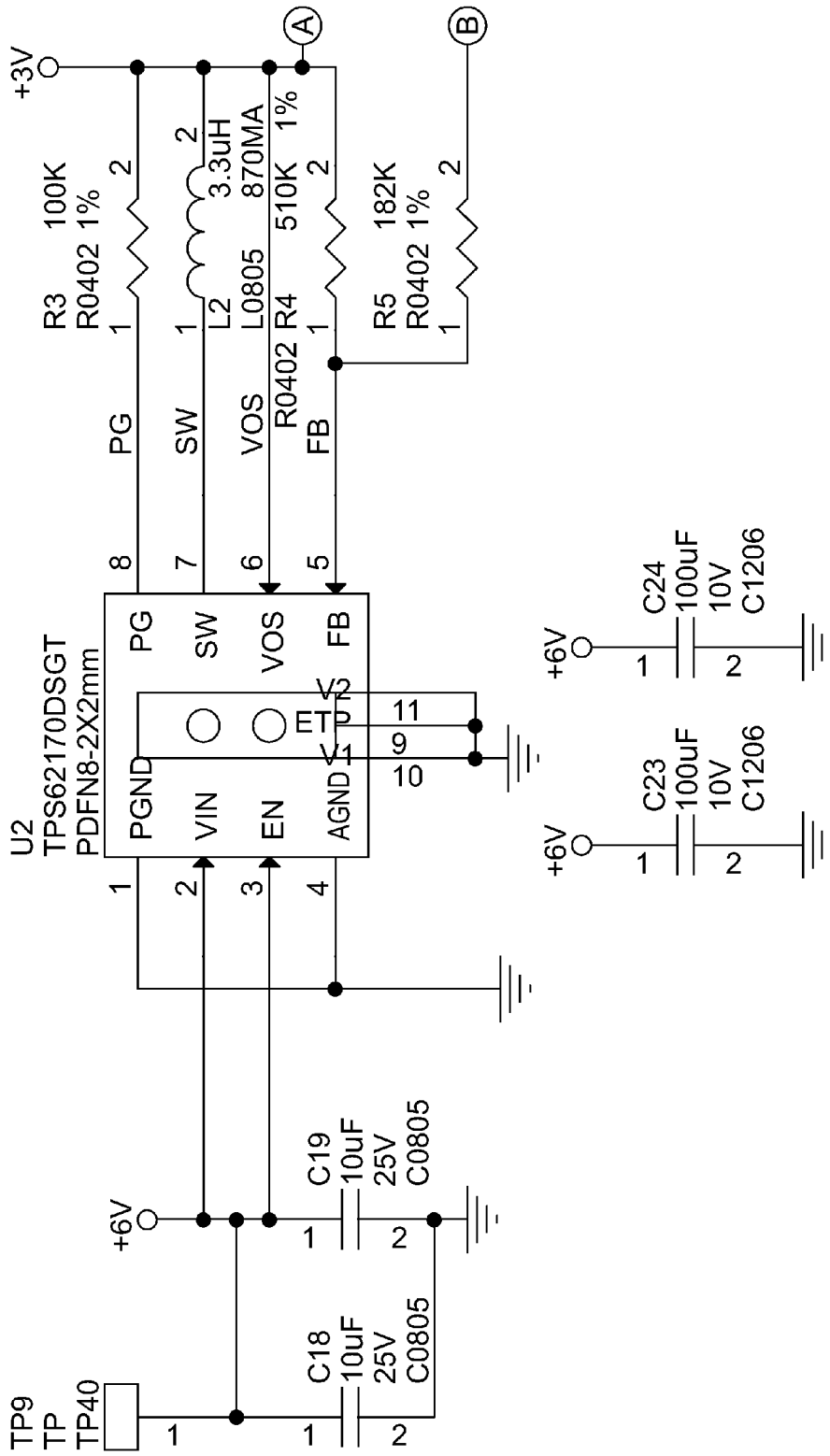

FIG. 10A (Cont'd)



BULK CAPS FOR LED'S STUFF AS NEEDED FIG. 10B

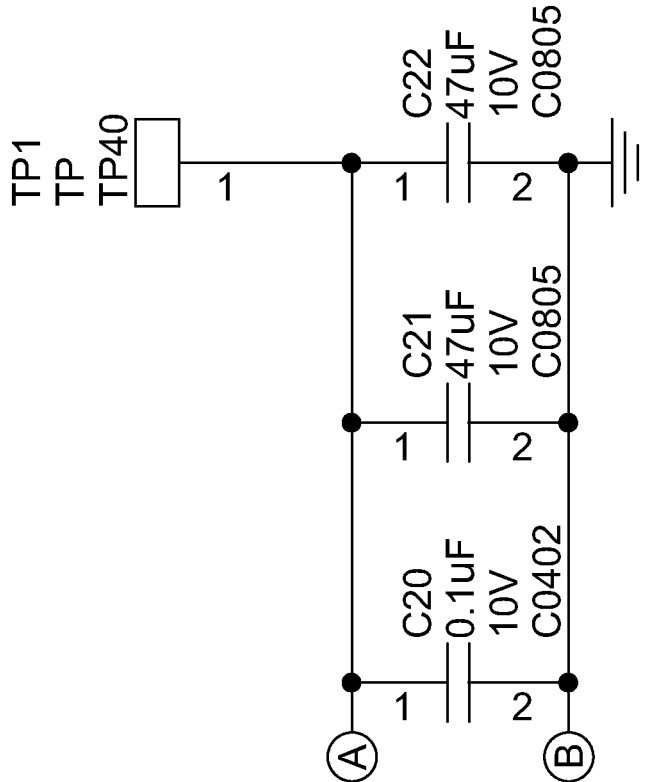

FIG. 10B  
(Cont'd)

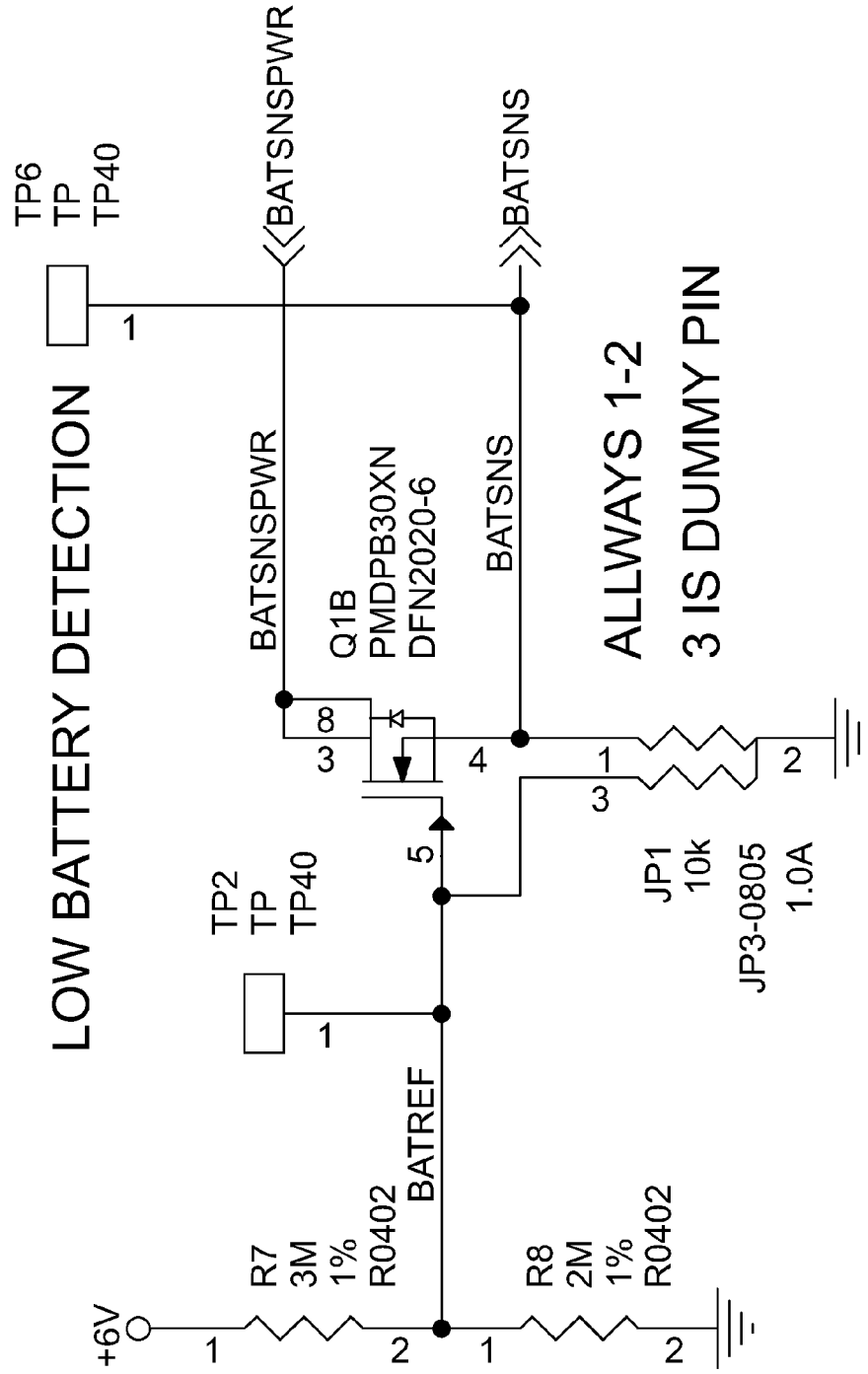
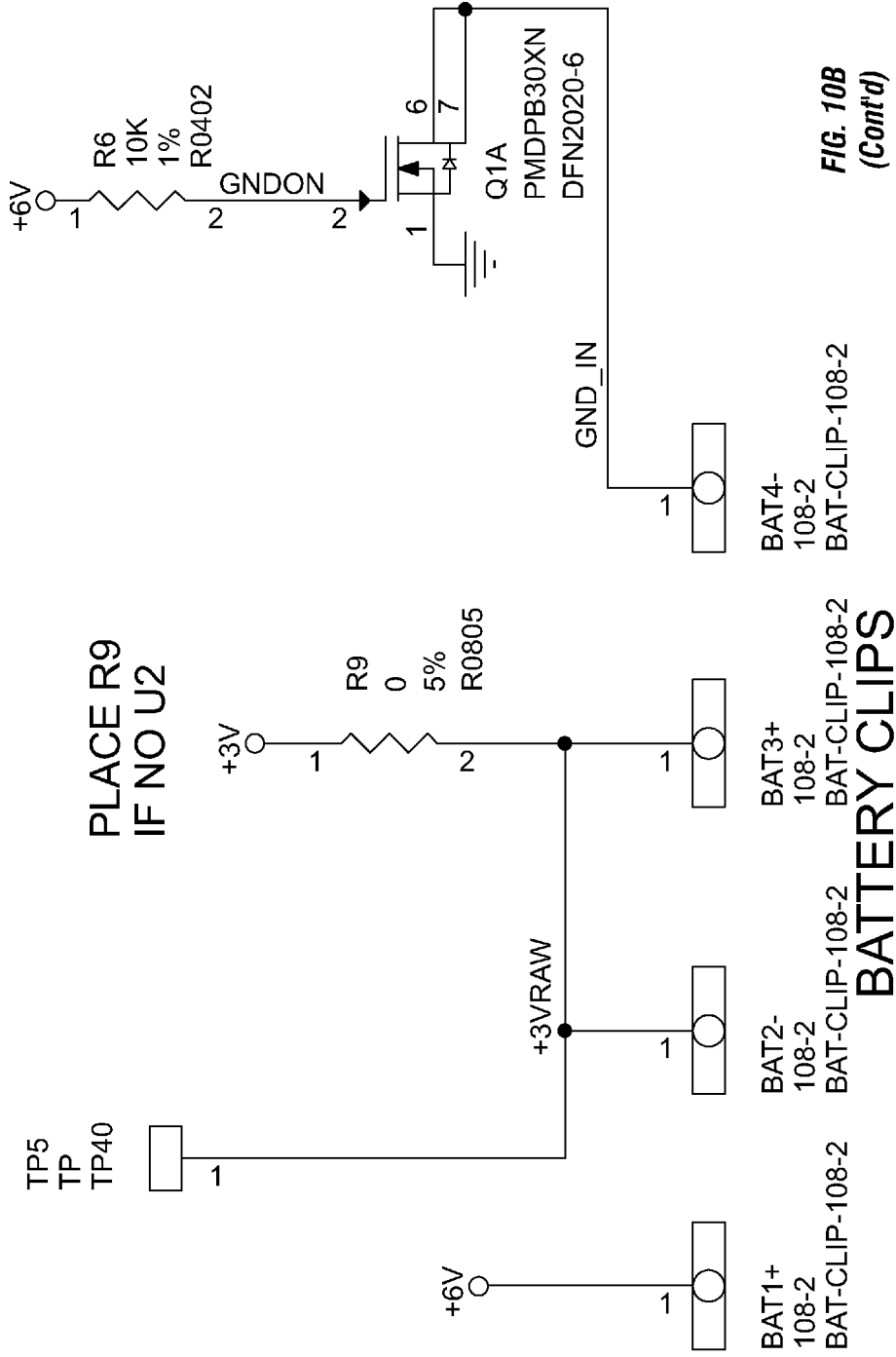

FIG. 10B  
(Cont'd)



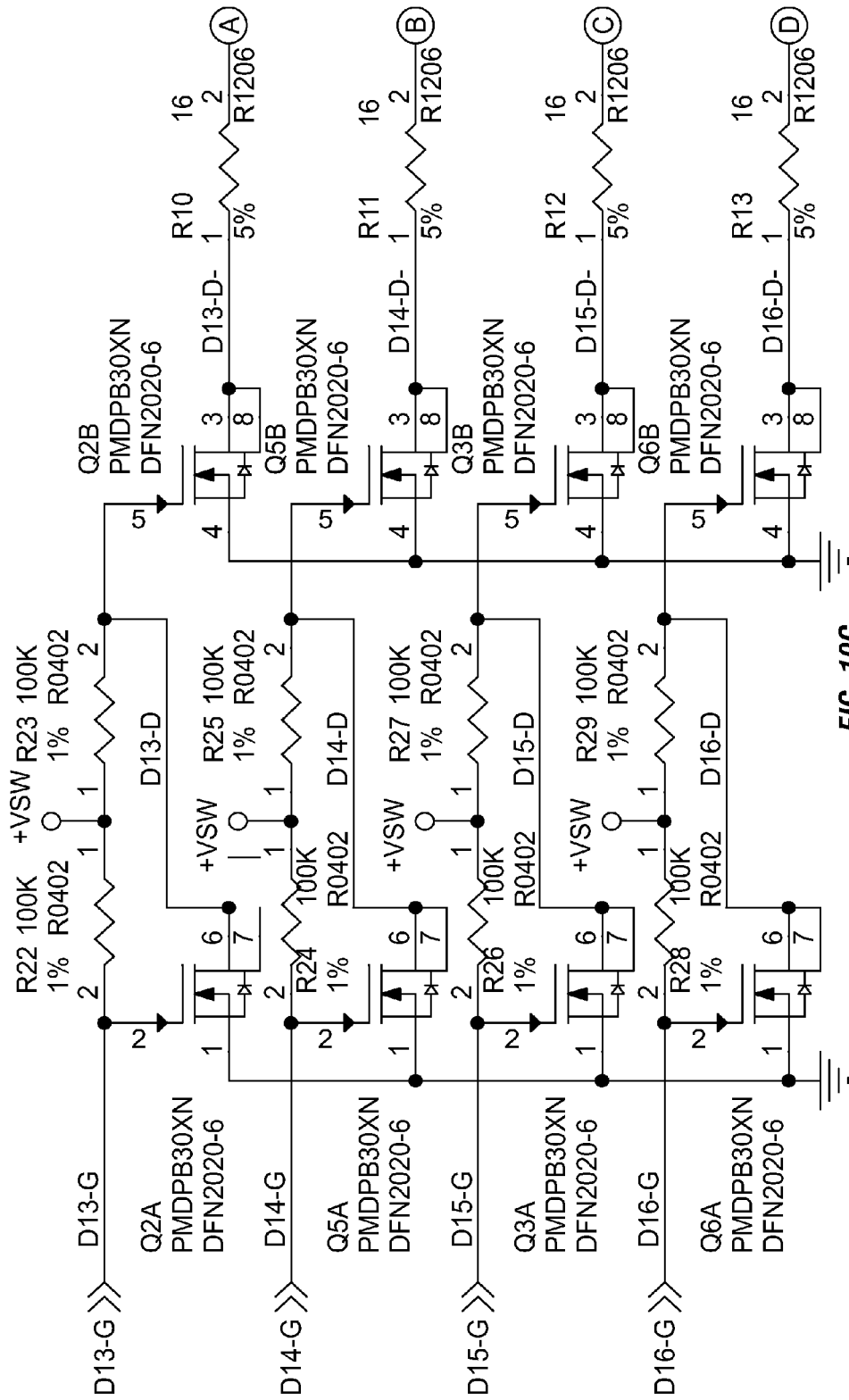

FIG. 10C



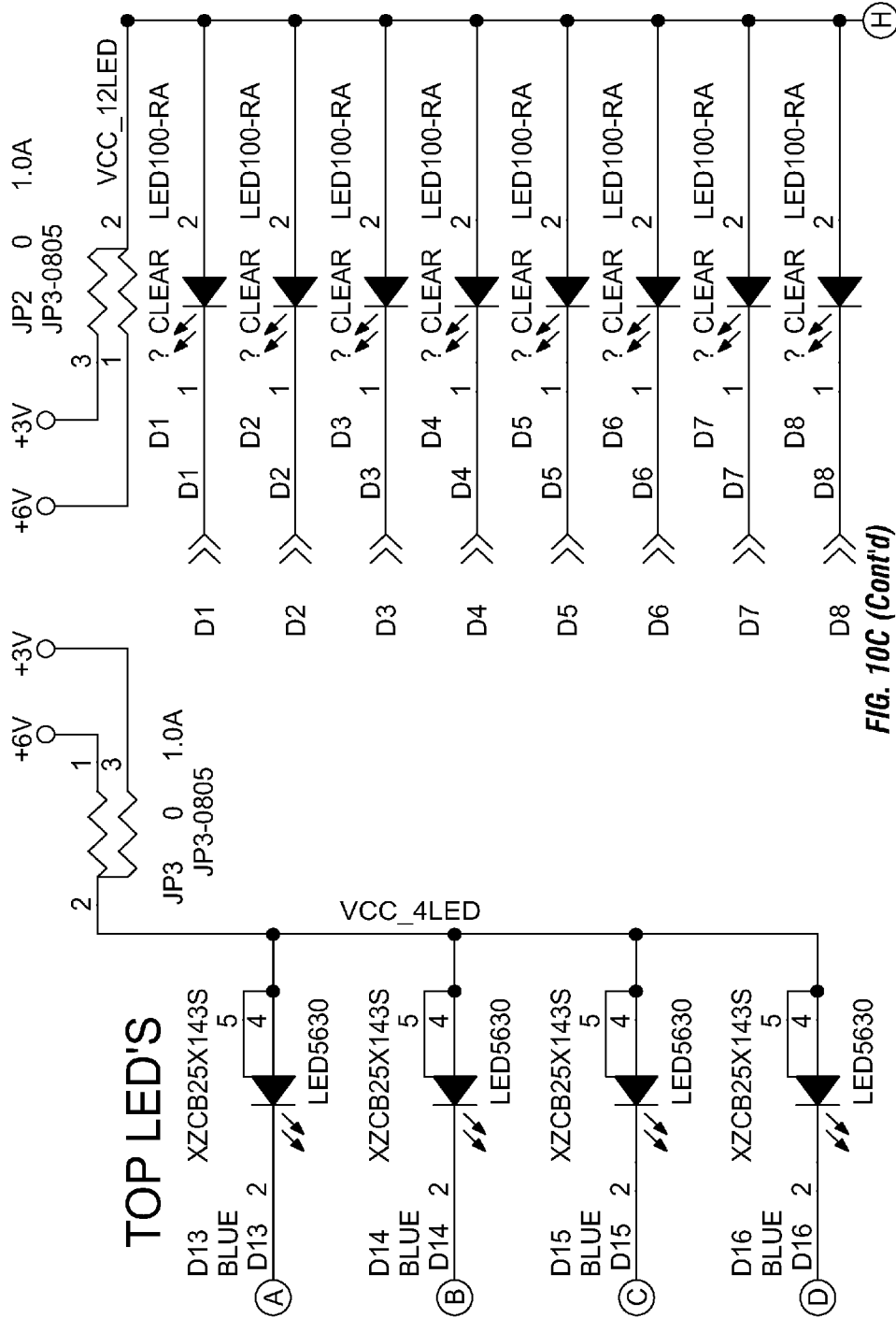

FIG. 10C (Cont'd)

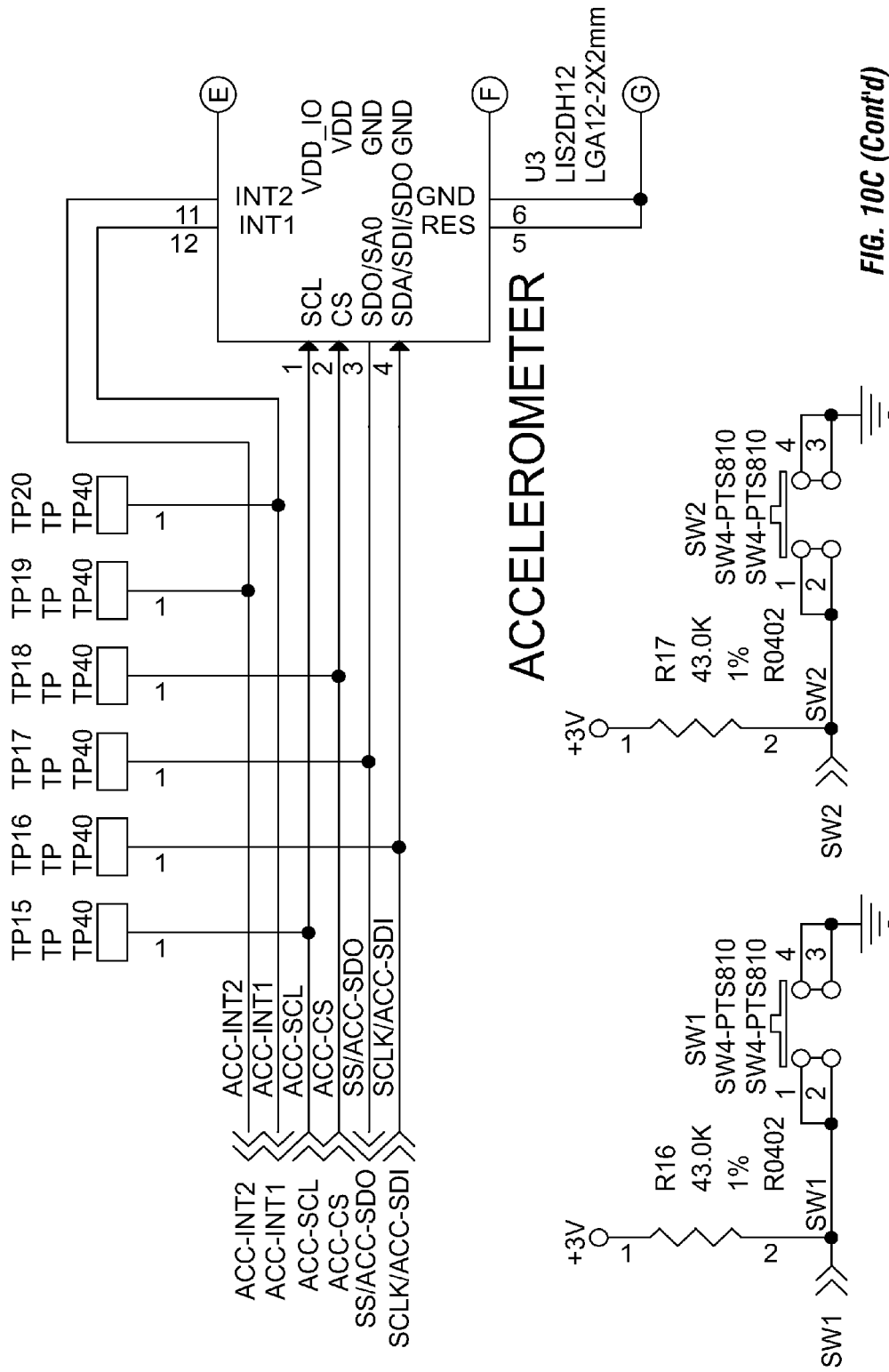

FIG. 10C (Cont'd)

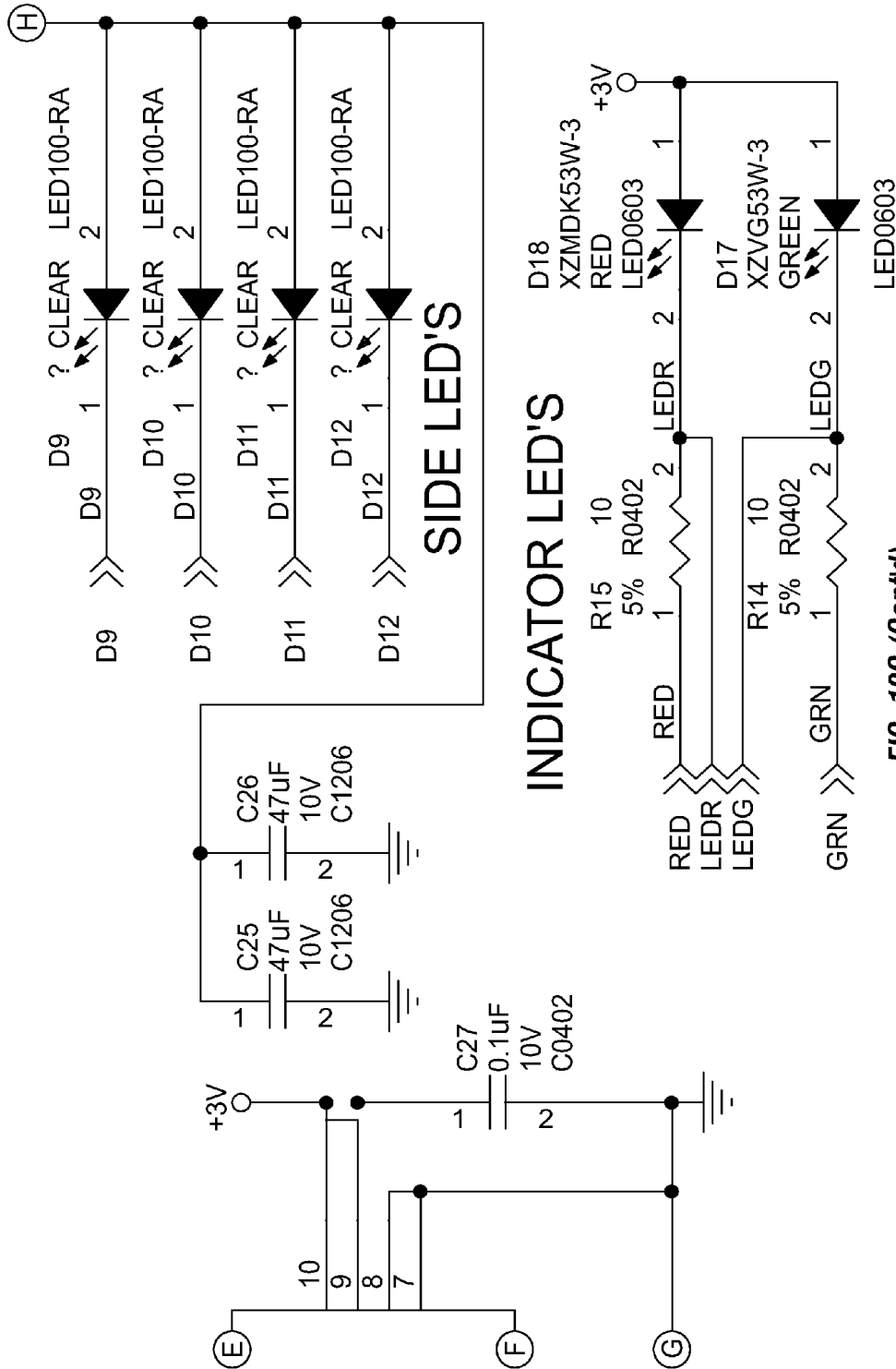

FIG. 10C (Cont'd)

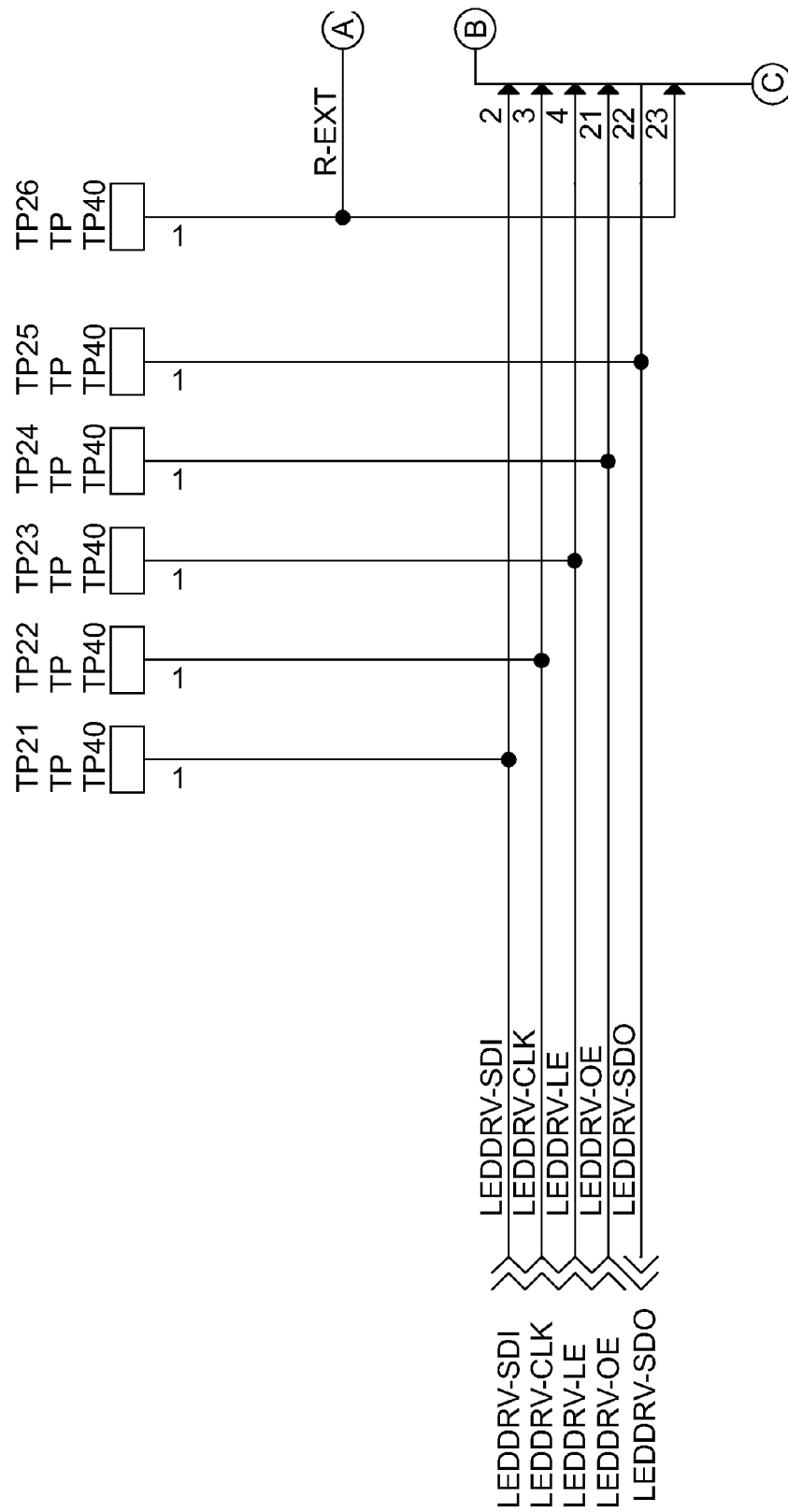

FIG. 10D



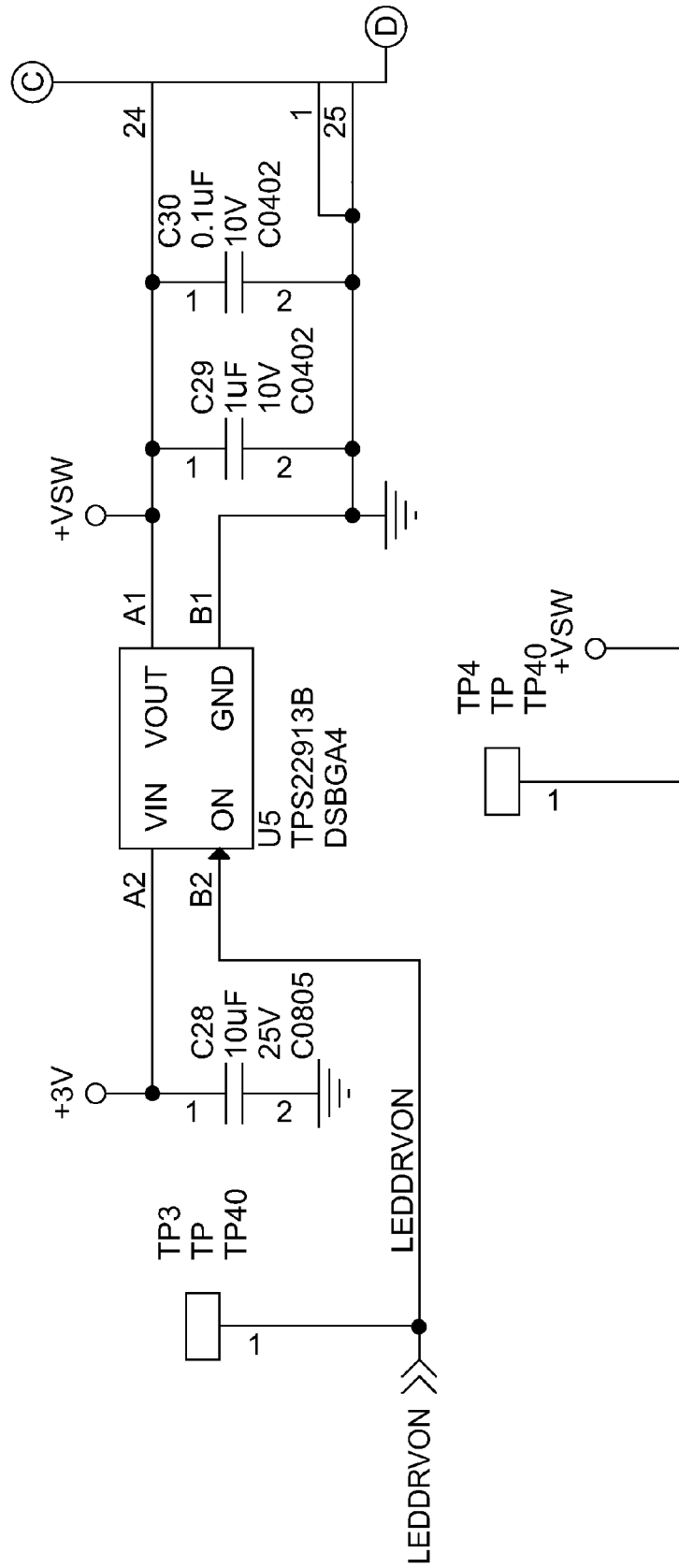

FIG. 10D (Cont'd)

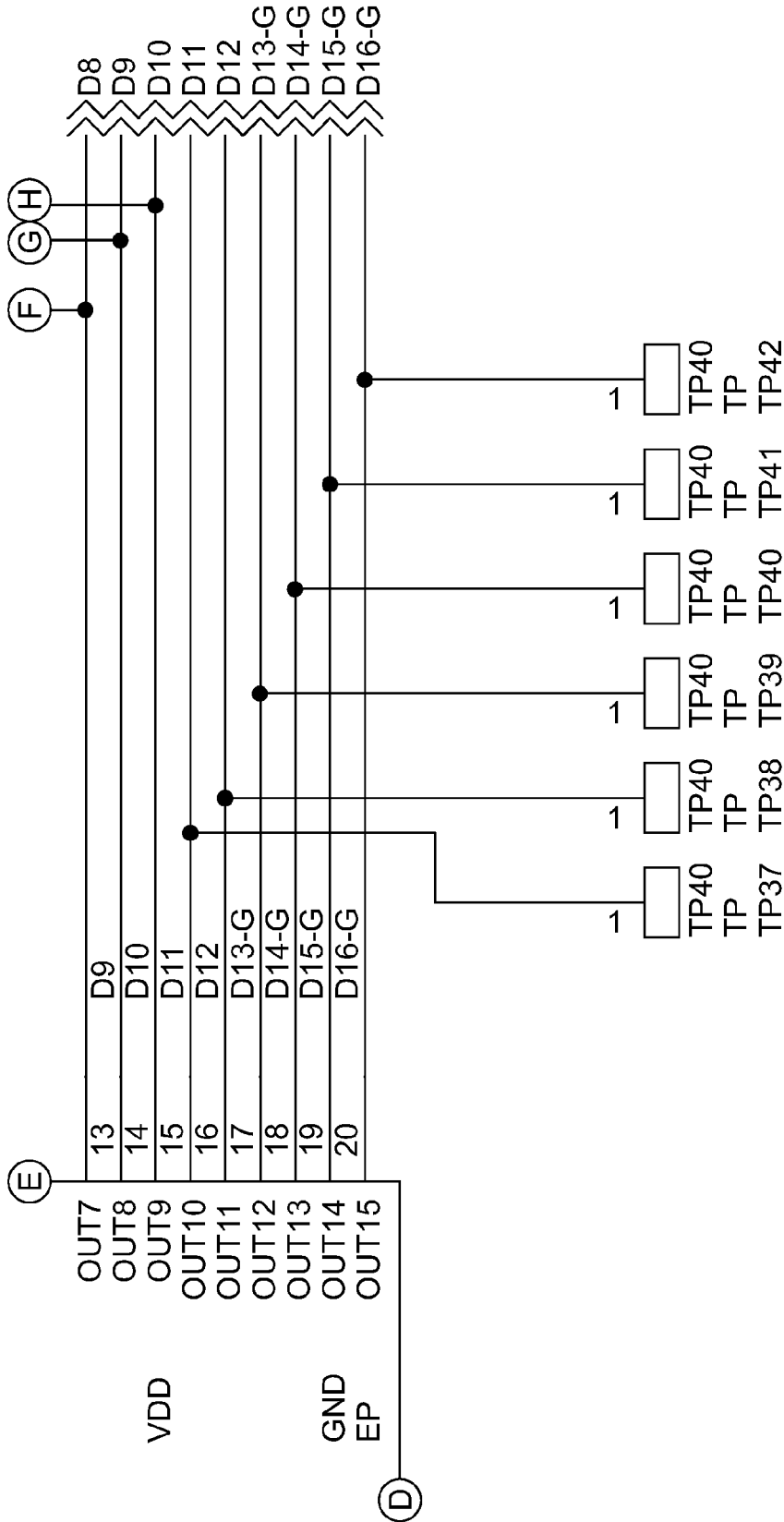

FIG. 10D (Cont'd)

**SEQUENTIAL AND COORDINATED  
FLASHING OF ELECTRONIC ROADSIDE  
FLARES WITH ACTIVE ENERGY  
CONSERVATION**

RELATED APPLICATIONS

**[0001]** This patent application claims priority to copending U.S. Provisional Patent Application No. 62/080,294 filed Nov. 15, 2014 and this patent application is also a continuation in part of U.S. Design patent application Ser. No. 29/525,453 filed Apr. 29, 2015, the entire disclosure of each such prior application being expressly incorporated herein by reference.

FIELD OF THE INVENTION

**[0002]** The present invention relates generally to the fields of electronics and traffic engineering and more particularly to flare devices and methods for marking hazards or intended routes of travel on roadways and the like.

BACKGROUND OF THE INVENTION

**[0003]** Pursuant to 37 CFR 1.71(e), this patent document contains material which is subject to copyright protection and the owner of this patent document reserves all copyright rights whatsoever.

**[0004]** Flashing orange traffic safety lamps are commonplace along highways and waterways. Passive cones are often used to mark the boundaries or edges of roadways. They are used during road construction, traffic detours, and for emergency to route traffic through unfamiliar redirection. These passive cones are typically used over an entire 24-hour period, which includes darkness and may include poor visibility. Always on, or blinking, lights or reflectors are often used to define the border of a road that has temporarily changed and no longer follows the path that drivers expect or have become use to seeing.

**[0005]** Traffic is often controlled using large, trailer-like signs with electric generators or photocells that are towed behind a vehicle and left at the detour site. These signs create a large arrow that directs traffic, but the arrow does not guide the driver around a curve or through unfamiliar road courses. Similarly, nautical traffic entering a harbor is guided via buoys and shore-based lights, which when set upon the backdrop of terrestrial lighting, can be confusing. Similarly, emergency or temporary aircraft runways for military, civilian, police, and Coast Guard air equipment, both fixed wing and rotary wing, lack proper sequenced lights that designate direction and location of the runway. This invention provides a system that is both low in cost and easy to implement, one that can be deployed quickly when necessary to aid aviators when landing or taking off on open fields or highways.

**[0006]** Also, traditional magnesium-flame roadside flares are sometimes used by first responders and workers to alert drivers to the presence of an emergency or maintenance event. There has been movement away from use of flame flares as they result in fire danger, pollution, and toxic fumes. Electronic flares that shine brightly on the roadside have begun to replace these ignited devices. However, frequently during a maintenance or emergency event there are numerous vehicles with roof-top and bumper-level red, orange, blue lamps flashing. This "light noise" can introduce confusion to an approaching driver.

**[0007]** In recent years, electronic roadside flares have been developed as alternatives to magnesium flame flares, reflectors, cones, markers and other previously used flares and marker devices.

SUMMARY OF THE INVENTIONS

**[0008]** The present invention provides new electronic flare devices and their methods of use.

**[0009]** In accordance with the present invention, there is provided an electronic light emitting flare and related methods of use wherein the flare generally comprises; a housing comprising a top wall, bottom wall and at least one side wall, wherein at least a portion of the side wall is translucent; a plurality of light emitters positioned within the housing; a power source; and electronic circuitry connected to the power source and light emitters to drive at least some of the light emitters to emit flashes of light directed through all or translucent portions of the housing side wall. As described herein, the electronic circuitry and/or other components of the flare may be adapted to facilitate various novel features such as self-synchronization, remote control, motion-actuated or percussion-actuated features, dynamic shifting between side-emitting and top-emitting light emitters in response to changes in positional orientation (e.g., vertical vs. horizontal) of the flare; overrides to cause continued emission from side-emitting or top-emitting light emitters irrespective of changes in the flare's positional orientation; use of the flare(s) for illumination of traffic cones and other hazard marking or traffic safety objects or devices, group on/off features, frequency specificity to facilitate use of separate groups of flares in proximity to one another, selection and changing of flashing patterns, etc.

**[0010]** Still further aspects and details of the present invention will be understood upon reading of the detailed description and examples set forth herebelow.

BRIEF DESCRIPTION OF THE DRAWINGS

**[0011]** The following detailed description and examples are provided for the purpose of non-exhaustively describing some, but not necessarily all, examples or embodiments of the invention, and shall not limit the scope of the invention in any way.

**[0012]** FIG. 1 is a left perspective view of an embodiment of an electronic traffic safety guidance flare;

**[0013]** FIG. 2 is a right side view of the embodiment of FIG. 1;

**[0014]** FIG. 3 is a left side view of the embodiment of FIG. 1;

**[0015]** FIG. 4 is a front view of the embodiment of FIG. 1;

**[0016]** FIG. 5 is a rear view of the embodiment of FIG. 1;

**[0017]** FIG. 6 is a top view of the embodiment of FIG. 1; and

**[0018]** FIG. 7 is a bottom view of the embodiment of FIG. 1.

**[0019]** FIG. 8 is a diagram illustrating one example of LED orientation in the flare device of FIGS. 1-7.

**[0020]** FIGS. 9A and 9B show steps in a method for using the flare device of FIGS. 1-7 for internal lighting of traffic cones.

**[0021]** FIGS. 10A through 10D are electrical diagrams of components of the flare device of FIGS. 1 through 7. Accompanying Appendix A lists components shown in the diagrams.



## DETAILED DESCRIPTION OF THE INVENTION

**[0022]** The following detailed description and the accompanying drawings to which it refers are intended to describe some, but not necessarily all, examples or embodiments of the invention. The described embodiments are to be considered in all respects only as illustrative and not restrictive. The contents of this detailed description and the accompanying drawings do not limit the scope of the invention in any way.

**[0023]** The ability to coordinate the pattern of illumination between electronic roadside flares enhances the approaching driver's perspective. Sequential flashing provides directional information, while simultaneous flashing provides a more dramatic "warning". One method of coordinating flash timing of roadside flares is to connect them via a single wire. However, this method does introduce the entanglement of the wire in the storage container, the potential for workers to trip over the wire, and delayed deployment.

**[0024]** Wireless coordination of flashing between flares (e.g., causing flares in a row or array to flash in consecutive sequence or other desired pattern) be accomplished using various different modalities, such as radiofrequency transmission, light, or sound waves.

**[0025]** Using a microcontroller, the flare can analyze sensors to establish a communication link. The media through which the information is transferred can be light, sound, or radio waves. The microcontroller will receive information from a radio receiver, light sensor, or sound sensor. Once the information about number and position of other sensors is received the microcontroller can then establish its position in the sequence and broadcast a message that tells other flares where it is in the string, its relative distance, temperature, elevation, etc.

**[0026]** For example, some embodiments of flare devices of the present invention may utilize flocking protocols to facilitate the desired inter-flare communication and function. Examples of flocking protocols are described in copending U.S. patent application Ser. No. 14/186,582 filed Feb. 21, 2014, the entire disclosure of which is expressly incorporated herein by reference.

**[0027]** Also, for example, some embodiments of flare devices of the present invention may utilize mesh networks to facilitate the desired inter-flare communication and function. Examples of such mesh networks are described in U.S. Pat. No. 8,154,424 issued Apr. 10, 2012 as well as United States Patent Application Publications US2013/0293396 published Nov. 17, 2013 and US2013/0271294 published Oct. 17, 2013, the entire disclosure of each such patent and published application being expressly incorporated herein by reference.

Approaches to Inter-Flare Communication: With and without Mesh Network

**[0028]** Light Transmission—

**[0029]** Using light as an information transmission media—Light emitted from one flare can represent a message that is received by another flare. This message could be as simple as a "trigger" event to tell the second flare to turn on, or it could be more complex. In the simplest form, presence of light from one flare would trigger an event in another flare. This second flare might delay, for example, 100 milliseconds and then flash. In the ideal setting this could represent a simple method of providing a sequential pattern of flashes. However, it is possible that flare number 4, for example, would receive light from flare number 1 and flash at an inappropriate interval. Thus, the sequential flashing of flares cannot rely upon the simple trigger of a preceding flare. Using the flash of a flare,

the message to other flares can be "embedded" within the light signal in a Pulse Width Modulated" scheme. Hence, what appears as a 40 or 100 millisecond (as an example) steady flash of light to the human observer can actually represent a 2, 4, 8, 16, 32, 64 bit or greater word length containing information that would provide coordinating information. The LED and associated drive electronics (microcontroller, transistors, etc.) can respond to signals and voltages that are nanoseconds in length. An 80 millisecond flash of light (appearing as a single flash to the human observer) can actually be made up of a series of thousands of rapid flashes "modulated" on and off so quickly that the human eye cannot discern the pulsed nature of the flash. For example, when the first flare is turned on it could "look" or "listen" for light that contains an identifying message (a digital word representing a "hello, I am a flare flashing". In the absence of seeing such a pattern it would start flashing with a modulated message to the effect. "I am flare number 1". When the second flare is turned on it will "look" for light speaking its same language. It would see light coming from flare 1 defining its sequence number (1). Flare 2 would then turn on and begin flashing with a modulated pattern defining its sequence number and so on.

**[0030]** The transmission of light is inherent in the flash of the flare. Hence, the orange or red or blue or other color LED flashing to alert drivers is also the light source to send the message. On each flare there will be a number of light sensors—photodiodes, photo-resistors, phototransistors, etc. These sensing devices will respond to the presence of any light in their frequencies (sensitivity) range. The photodetector could be chosen or "tuned" to respond to only one color. However, the presence of the digital word modulated in the warning flash eliminates the need to narrow the sensitivity spectrum of light. Any light sensed by the photo-detector will represent "noise", but only light modulated with the appropriate digital code will result in the microcontroller responding correctly.

**[0031]** To reduce cost, the physics of the Light Emitting Diode that emits the light (flash) could be used to an advantage by also being used as a light sensor. During the period when the LED is not flashing the voltage on the LED could be reversed. During this period when the voltage is reversed the LED can be used as a light sensor to pick up transmitted light from other flares. This would eliminate or mitigate the need for additional photo-detectors. Furthermore, as there are often 12 or more LEDs on roadside electronic flares, each of these could be used as a photo-detector thereby "looking" in a 360 degree circle. Thus, the orientation of the flare on the roadway is irrelevant; the operator can toss the flares onto the roadway without regard for whether it is pointed in a particular direction to pick up the light beam from an adjacent flare.

**[0032]** Alternatively, light of a specific frequency or spectrum could be used to transmit information. For example, light in the infra-red or ultra-violet frequency range could be used. Photo-detectors sensitive to only these frequencies would filter out "noise" present on the roadway at night. Sunlight (white light) would contain energy in all spectrums, and thus the information content (Pulse Width Modulation) would ensure that light noise does not interfere with the intelligent transfer of information.

**[0033]** Light intensity in addition to color and modulation adds additional information to the microcontroller. As the intensity of light diminishes in a known and predictable way with distance, the "brightness" or intensity of light emanating from a flare can aid in determining sequence. In the simple

case of using the flash of a flare as a triggering action, the relative intensity of the received light could “disambiguate” light emitted from two or more flares. If the lights are physically placed in a linear “string” or path and flare number 5 senses light from flare number 4 and number 3, it could identify which is which by measuring the intensity of the light received. It would then be able to identify number 3 (weaker flash therefore farther away) and number 4.

**[0034]** Radio Transmission—

**[0035]** Light represents an inexpensive means of transmitting information between flares. However, there are limitations associated with light energy. The transmission of light is inefficient when compared to radio transmission. Light can be blocked by opaque objects that might find their way between the flares (cars, people, cones, etc.). The range of transmission is limited due to energy requirements. Radio transmission provides a solution to these limitations. Using radio waves a flare could send digital or analog signals to other flares that identify its sequence in the pattern much in the same way as light could be used.

**[0036]** Sound Transmission—

**[0037]** Ultrasonic or other frequency sound can be used as a transmission media. Modulated sound waves could carry information defining flare number and location relative to other flares. In addition, sound waves diminish in strength in a relative and predictable way, the strength of the sound “heard” from two different flares at different distances would aid the microcontroller firmware in establishing which is farther away and what the sequence number is. In addition, once the sound is sensed by appropriate transducers and electronics the frequency could be filtered to eliminate noise produced by vehicles on the roadway.

**[0038]** 4) Irrespective of the transmission media, the flares can be networked using a “mesh” network where information is transmitted between flares, up and down a group, without need for a master flare or slave flare, and where all communication is internal to the group of flares. No external signal is required, but could be used to remotely control the group of flares. If one flare is turned on and it is in “range” of communication with only one flare, this second flare would then send the “state” to any other flares within range. Similarly, the remote control unit needs to be in range of only one flare for the command to be distributed to all of the flares.

Control of Direction of Warning Light Emitted by the Flare and Energy Conservation:

**[0039]** To be practical roadside flares must be small and lightweight. An individual might deploy 10 flares on the roadside and stowing 10 objects in a vehicle requires small size. Small size and light weight define limits on the battery size and available energy. Hence, methods to reduce energy consumption are key factors in designing a roadside flare. One method is to turn off (not illuminate) LEDs oriented in a direction not seen by on-coming vehicles. All existing roadside flare designs power all LEDs with each flash. An approach that would reduce significantly the energy required and prolong battery life is to sense the direction of traffic flow. This can be done using light from on-coming headlights, sound intensity, sound frequency (Doppler Effect of a passing vehicle), thermal detection of engine heat, radar, ultrasound, sonar, and air pressure. When the direction of traffic is detected, the microcontroller will turn off LEDs that would illuminate the “back” side of the flare.

**[0040]** In a similar fashion, the flares can be mounted in a vertical position (as opposed to horizontal on the road surface). This vertical orientation might be used when magnetically attaching the flare to the tail-gate panel of a truck or the side of a vehicle. As the flare is designed for light output in the horizontal plane (on the road surface), when placed vertically much of the light energy would be directed towards the sky, ground, and left and right. Accordingly, a sensor could detect the “tilt” using an accelerometer, gyroscope, MEMS device, mechanical ball tilt sensor, thermal tilt sensor, light detecting tilt sensor, etc. and send this information regarding orientation angle to the microcontroller. The microcontroller, “aware” of the angle of tilt, would choose which LEDs to illuminate (for example, the side LEDs when horizontal and “top” LEDs when mounted vertically on its side or magnetically attached to the tail gate of a vehicle). This dynamic choice of LED to illuminate based upon angle of tilt maximizes light output in the direction of approaching traffic and minimizes unnecessary battery consumption associated with lighting LEDs not visible to oncoming traffic. When placed in the vertical plane the side lights could be turned off and LEDs located in the top of the flare directed towards on-coming traffic could be turned on.

Optional Features to Facilitate Deployment and Retrieval of Roadside Flares:

**[0041]** Motion-Actuated or Percussion-Actuated on/Off Feature:

**[0042]** In some instances, such as during nighttime operation in areas which are not well lit, it may be difficult to see standard buttons on the surface of an enclosure. Rather than using a discrete on/off switch such as a capacitance button or other specifically-located actuator to cause the flare to begin emitting light (i.e., “turn on”) or cease emitting light (i.e., “turn off”), the flares of the present invention may optionally be equipped with an on/off switch which is activated by a motion or percussion sensor, such as an accelerometer, tilt sensor, gyroscope or MEMS (micro electrical mechanical system) set to detect a particular movement of, or percussion (e.g., tapping) on the flare. For example, the electronic circuitry of the flare may be adapted so that rapid partial rotation of the flare in a first (e.g., clockwise) direction causes the flare to turn on and subsequent rapid partial rotation of the flare in the opposite (e.g., counterclockwise) direction causes the flare to turn off. Alternatively, on and off might be triggered by turning the flare upside down, or via some other motion or percussion. As a further example, percussing (e.g., tapping or rapping) the flare with the palm of the operator’s hand could be used as a trigger to turn the flare off or on, with the sensor “tuned” to exclude normal vibration to be expected during transport and storage. For example, the circuitry may be adapted to recognize a specific number of consecutive percussions (e.g., three consecutive taps or raps) as the signal to cause the flare to initially turn on or subsequently turn off. Alternatively or additionally, to avoid unintended turn on of the flare, which could result in rapid unintentional depletion of the battery, a 3-axis accelerometer may be used to detect acceleration in the X, Y, and Z axis. For example, simply turning the flare over three times within a defined period (e.g., 3 seconds) would result in the Z-axis experiencing a swing from +9.8 meters per second per second (+1G) to -1G. The microcontroller would receive this information from the accelerometer via an interrupt signal. This pre-programmed “gesture”, stored in the accelerometer, would generate an

interrupt from the accelerometer, and this interrupt would “wake” the microcontroller from a low-power “sleep” mode. Hence, the microcontroller can be in a low-power state (sleep) while the device is off. The accelerometer has sufficient intelligence to recognize the pre-programmed gesture and wake the microcontroller from its low power mode. The pre-programmed gesture must utilize the X, Y, and Z axis to insure proper turn-on but avoid false startup. When horizontal, the X and Y axis experience 0 (zero) acceleration. Only the Z axis is experiencing +1G. However, if the surface is bumped up and down the accelerometer would experience acceleration on the Z-axis only and this could mimic turning the flare over to the other side. Thus, the flare would turn on if three bumps of sufficient magnitude occurred within the allotted time period.

**[0043]** To avoid this false trigger, X- and Y-axis information is introduced. A simple bounce of the horizontally-oriented flare in the trunk of the car would be interpreted as turning over of the flare (Z-axis would transition from +1 G to -1G). If X- and Y-axis changes were expected as well, then vertical displacement alone would not falsely turn on the flare. For the Z-axis to experience +1G to -1G, X- or Y-axis must transition from 0G to +1G (or -1G) to 0G. Introducing the Boolean—(Z-transition AND ((X-transition from 0G to +/-1G to 0G) OR (Y-transition from 0G to +/-1G to 0G))) eliminates “bumps” alone as a triggering event.

**[0044]** Group on/Off Feature:

**[0045]** Some embodiments of the invention may be equipped with a group on/off feature whereby turning off any one of the flares would turn off all of the flares in the group. Using radio, sound, light, etc., to transmit information between flares one could send a message from any one flare to the remainder of flares within proximity. This message could be used to turn off all of the flares by simply turning off any single flare.

**[0046]** The ability to turn all of the flares off by turning off a signal flare allows the operator to retrieve the flares from the roadside while they are still flashing. This would reduce the likelihood that a flare would be inadvertently left behind on the dark roadway. In addition, when placed into a transparent or translucent case or satchel the flashing group of flares would represent a warning beacon to oncoming traffic that the operator is on the side of the road. When all of the flares have been retrieved, the operator could enter the safety of their vehicle or exit the roadway and turn off any one flare. The entire group of flares would extinguish. The operator does not have to turn off all of the flares individually.

**[0047]** Elevation of the LED above the road surface may vary as a function of position in the string. To aid in providing direction and visibility, the height of the LEDs providing illumination could vary. For example, in a 10 flare string flashing in sequence, the height above the road surface of number 1 could be 3 inches, with each flare progressing in height by 6 inches. As a result, the last flare in the string might be 5 feet above the road surface (on a flexible stalk). This would add additional perspective for a driver from a distance, offering linear as well as elevation cues to the hazard ahead.

**[0048]** Locking Feature:

**[0049]** With LEDs aimed in specific directions, including vertically towards the sky, the flare is designed to purposely illuminate the inside of a container, barrel, cone, or delineator. When placed on the road surface under a traffic cone, barrel, delineator, etc., light emanating from the flare in the vertical direction efficiently illuminates the container. However, light aimed vertically when the flare is on the road surface and not

placed under a container leads to inefficiency of energy use as this light is directed skyward. Dynamic switching of side versus top (vertical) LEDs is accomplished using a tilt sensor (accelerometer) and the information the sensor provides to the microcontroller. It is necessary, when placed under a container, to override the tilt sensor. The user must be able to “lock” the choice of LEDs (top or side) for a particular deployment. This effectively disables dynamic, tilt-sensing microcontroller control of the LED choice.

**[0050]** The “locking” feature can be activated by pressing two buttons simultaneously, or by pressing and holding one button for a prolonged switch closure (2 seconds or more, for example). Alternatively, a single tap of a button could lock the orientation of LED illumination, or step through choices such as a single press turns on the side LEDs, a second press turns on the top LEDs, a third press turns on both side and top LEDs, and the cycle repeats itself with additional presses of the button.

**[0051]** Motion Actuated LED Switching,

**[0052]** dynamic switching of LED orientation using a tilt sensor or accelerometer, locking of LED orientation using various user interface button presses, all can be implemented in either a standalone flare or one communicating with its neighbors.

**[0053]** All of the features described thus far, save for the “group off” capability, can be incorporated in either: a “smart flare” that incorporates mesh or flocking technology (radio frequency, light transmission, infrared transmission, sound, transmission, etc.) for flare-to-flare communications or in a “dumb” flare used individually or in a group wherein the flares do not communicate with each to synchronize their flashing, but rather flash randomly in non-synchronized fashion.

**[0054]** FIGS. 1 through 7 show one a non-limiting example of a flare 10 of the present invention. FIGS. 10A through 10D are electrical circuit diagrams for this embodiment of the flare 10 and Appendix A sets for a component list that corresponds to the electrical diagrams of FIGS. 10A through 10D. having a generally rectangular configuration with rounded corners. This example is non-limiting and other alternative configurations or shapes may be used. The flare 10 of this example comprises a top wall 12, bottom wall 14 and side wall 16. The side wall 16 is translucent. Also, translucent windows 23a, 23b, 23c and 23d are formed in the top wall 12. In some embodiments, the entire or substantially all of the top wall 12 may be translucent. Also, in some embodiments the bottom wall 14 may be entirely or substantially non-translucent or devoid of any locations where light is directed from or through the bottom wall.

**[0055]** Defined within the walls of the flare 10 is an interior area which houses a battery, electronic circuitry and a plurality of LEDs. Some of the LEDs (i.e., side-emitting LEDs) are positioned to direct emitted light through the translucent side wall 16 so that light is projected around (e.g., 360 degrees) the flare 10. FIG. 9 shows an example of how the side-emitting LEDs may be positioned to cast their light through the side wall 16 such that the light will be visible 360 degrees around the flare 10. Also, in some embodiments, the side-emitting LEDs may be slightly angled upwardly such that the emitted light will rise from the flare 10 when the flare is positioned bottom-side-down on the ground or roadway surface. For example, if the side-emitting LEDs are angled 5 degrees

above horizontal, light from the side-emitting LED's will be clearly visible to motorists approaching from a distance of about 120 feet.

**[0056]** Other LEDs (i.e., top-emitting LEDs) are positioned to direct light through the translucent windows **23a**, **23b**, **23c**, **23d** in the top wall **12** of the flare **10**. On the top wall **12** of the flare **10** are a control button **18**, a power button **20**, a small green indicator LED **22a** and a small red indicator LED **22b**. The control button **18** is also referred to herein as the pi ( $\pi$ ) button. The bottom wall **14** may be fully, substantially or at least partially opaque or non-translucent. A portion of the bottom wall **14** comprises a battery compartment cover **30** which is held in place by latches **28**. When it is desired to access or change the battery or batteries, the latches **28** may be opened and the battery compartment cover **30** removed. In the embodiment show, four (4) AA cell batteries are positioned inside the device under the battery compartment cover **30**. Other alternative power sources, including solar collectors and/or rechargeable batteries, may be used instead of the standard AA cell batteries of this embodiment.

**[0057]** The following paragraphs describe possible methods of use of a plurality of these flares **10** in a group (e.g., a row or array).

**[0058]** Turning on the First Flare:

**[0059]** To turn on the first flare **10** of the group, the power button **20** is briefly depressed or tapped. Once the power button is pressed a steady green LED **22a** on the top wall **12** will illuminate. This indicates that the flare and radio are powering up. The first flare **10** will take approximately 4 seconds to turn on. At the end of the 4 seconds the green LED will disappear and, if the flare **10** is positioned horizontally, 12 side-emitting LEDs will emit flashing light directed through the side wall **16**. Alternatively, if the flare is positioned vertically, 4 bright top-emitting LEDs will emit flashing light through the top wall windows **23a-23d**.

**[0060]** Turning on Additional Flares:

**[0061]** Once the first flare **10** is on and flashing, the operator may briefly depress (e.g., tap) power button **20** of another flare in the group. Similar to the first flare **10**, once the power button **20** is pressed a steady green LED will illuminate on the top wall **12** of the second flare **10**, indicating that the second flare is powering up. This second flare **10** will take about 1 second to turn on. At the end of the 1 second period the green LED will disappear and the side-emitting LEDs or top-emitting LEDs of the second flare **10** will begin to flash depending on the orientation (i.e., vertical or horizontal) of the second flare **10**. Because the flares **10** have self-sequencing capability such as the above-described mesh network or flocking protocol, the 2nd flare **10** will automatically identify itself as the second flare in the sequence and will begin to emit flashes of light in sequence (i.e., a specific time after) flashes emitted from the first flare **10**. This set up procedure is then repeated for the remaining flares **10** in the group. Each preceding flare **10** must be flashing (and this transmitting its sequence number) before turning on the next flare **10**. For maximum range, each flare **10** may initially be held above the ground in line-of-site of the preceding flare when turning on, thereby ensuring that the flare **10** will receive the radio signal from the preceding flare without attenuation of the signal due to proximity to the ground.

**[0062]** Turning Off Flares:

**[0063]** There are 2 ways of powering down the flares. 1) Single Flare Off—You can turn off a single flare by pressing and holding (2 seconds) the square pi ( $\pi$ ) button. A red LED

will flash twice indicating it has turned off; 2) Group Off—You can turn off the entire string of flares by simply holding down the Power button for 2 seconds. The red indicator LED flashes while the off command is being sent up and down the string. You must wait until the red LED stops flashing before turning a flare back on.

**[0064]** All of the flares in the group may be picked up all the flares and placed in a carry case while they are still flashing. This will help to prevent the user from inadvertently leaving inoperative flares on the side of the road. In addition, the carrying case may be constructed such that the flares flashing inside of the case will cause the case to illuminate thereby enhancing the ability of oncoming vehicle drivers to see and avoid a user who is carrying the case. When the use if safely in the user's vehicle or otherwise away from vehicular traffic, the user may then hold down the power button **20** on any one of the flares **10** in the case, thereby causing all of the flares **10** in the case to power off.

**[0065]** Remote Control of Flare Behavior:

**[0066]** By virtue of the communication and network features of the flare, any communication between flares to pass along flash pattern, top versus side LED choice (for battery saving), on/off, sequence pattern (one flare marching, two flares marching, fast march, slow march, etc.) can be mimicked by a remote control device, Smart Phone app, cellular communication, infra-red controller, etc. Accordingly, the operator can turn and off the entire group of flares, control the operation, direction of flash, battery saving, flash pattern, amongst other features, from a distance away from moving vehicles and in the safety of their vehicle. They need not be close to flare number 1, as any flare in the mesh network or "flock" passes all commands to all flares in the network or "flock". The operator could be close to number 20 of 30 flares and control the entire network.

**[0067]** The ability to inhibit the LED flashing while maintaining radio communication is a key feature in battery savings. Law enforcement, for example, will set up an alcohol check point using flares to alert and guide approaching vehicles. They typically will set up the DUI check point several hours prior to actual beginning surveillance. If the flares were flashing during this entire period and the 8 hours of the active surveillance battery consumption would be excessive. However, with a remote control unit the operator could set up the flare pattern, test that they are flashing as desired, and then "inhibit" the flashing of the LEDs to save battery. The continuing radio communication maintains sequence numbers, patterns, direction of flashing LEDs, etc., and occurs during milliseconds each second and consumers little power. Hours later when the operator wishes to commence inspection of vehicles, she can simply tap a button on the remote control to turn on the flashing LEDs. It is the LEDs that consume the majority of battery capacity and this capability mitigates this cause of battery drain.

**[0068]** Battery Status Check:

**[0069]** Pressing the pi button **18** while the flare **10** is off will effectuate a batter check. The green or red LED on the top wall **12** will flash the current battery status, as follows: 5 green flashes=full batteries, 4 green flashes=full batteries, 3 green flashes=good batteries, 2 red flashes=low batteries, 1 red flash=very low batteries. Preferably, in this embodiment, the batteries are replaced between the 3 green flashes and 2 red flashes.

**[0070]** Dynamic LED Orientation:

**[0071]** In some embodiments, the flare **10** may be equipped with an accelerometer or gravity sensor, as discussed above and the accelerometer or gravity sensor may be operative to sense the current orientation (i.e., horizontal or vertical) of the flare **10** and to cause either the top-emitting or side-emitting LEDs to emit light, depending on which orientation is sensed. When the flare **10** is in the horizontal orientation (lying flat on the ground) the **12** side-emitting LEDs will emit flashes of light through the translucent side wall **16**. When the flare **10** is in the vertical orientation (e.g., e.g., when magnetically attached to the back of a truck tailgate) the 4 top-emitting LEDs will emit flashes of light through the top wall windows **23a-23d**. Unless the locking feature is engaged, the flare **10** will default to a “dynamic positioning” mode wherein the accelerometer or gravity sensor will cause the flare **10** to automatically switch back and forth between side emitting mode and top emitting mode as the flare **10** undergoes changes between horizontal and vertical orientation.

**[0072]** Locking Feature/Override of Dynamic LED Orientation:

**[0073]** In this example, the flare **10** is equipped with the above-described locking feature which overrides the default dynamic positioning mode of the flare **10**. Use of this locking feature allows the flare **10** to be locked in top-emitting mode so that it will continue to emit flashes of light directed through the top wall windows **23a-23d** even when the flare **10** is placed in a horizontal orientation. To trigger this locking feature, after the flare **10** has been powered up and is flashing in either the horizontal or vertical mode, the pi ( $\pi$ ) button **18** is pressed. Pressing the pi button **18** one time while the flare **10** is operating overrides the dynamic LED orientation and causes the flare **10** to be locked in top-emitting mode with the bright top-emitting LEDs emit flashes of light through the translucent windows **23a-23d** in the top wall **12** of the flare **10** and the side emitting LED off. The green indicator LED **22a** will flash once to indicate that the flare is locked in the top emitting mode. Pressing the pi ( $\pi$ ) button **18** a second time will cause the flare **10** to transition to and become locked in side-emitting mode, wherein the side-emitting LEDs emit light through the side wall **16** and the brighter top-emitting LEDs are turned off. The green indicator LED **22a** will then flash twice to indicate that the flare **10** is now locked in side-emitting mode. Pressing the pi ( $\pi$ ) button **18** a third time will disengage the locking feature and restore the flare **10** to its default dynamic LED orientation mode. The green indicator LED **22a** will flash three times to indicate the flare is now in the default state.

**[0074]** Patterns:

**[0075]** Once a plurality of the flares **10** are operating, the user has the option of choosing between 5 flashing patterns. To change patterns, the operator simply taps (does not hold) the power button **20** on one of the flares **10** in the group. This will cause the flare to cycle through a series of available flashing patterns, e.g., Pattern 1 (default), Pattern 2, Pattern 3, Pattern 4, Pattern 5, and back to Pattern 1. In this example, the default Pattern 1 is a bright, slow and smooth pattern. Pattern 5 is a fast pattern, Pattern 2 is two flares **10** flashing as a pair and marching down the string of paired flares, and Pattern 3 is two flares flashing separated by a non-flashing flare, thereby spacing the flash out. Pattern 4 is a tail-off flash pattern. Once one of the flares **10** in the group is changed to a non-default flash pattern, all of the remaining flares **10** in the group will

then self-synchronize to that selected flash pattern due to the mesh network or flocking protocol used, as described above.

**[0076]** Changing Batteries:

**[0077]** In this example, no tools are required to open the battery compartment to change the batteries. The battery cover latches **28** may be manually moved to their open positions and the battery cover **30** may then be removed to access the battery compartment.

**[0078]** Multiple Groups:

**[0079]** Should the operator wish to use several strings or groups of flares **10** in close proximity, the flares **10** can be assigned to specific groups and set to different group frequencies. Flares in each group may be may bear identifying marks (e.g., yellow, blue green, beige, or black dots) to indicate different groups. For example, different police units might carry different group numbers so that they do not interfere with each other when deployed in close proximity.

**[0080]** It is to be appreciated that, although the invention has been described hereabove with reference to certain examples or embodiments of the invention, various additions, deletions, alterations and modifications may be made to those described examples and embodiments without departing from the intended spirit and scope of the invention. For example, any elements, steps, members, components, compositions, reactants, parts or portions of one embodiment or example may be incorporated into or used with another embodiment or example, unless otherwise specified or unless doing so would render that embodiment or example unsuitable for its intended use. Also, where the steps of a method or process have been described or listed in a particular order, the order of such steps may be changed unless otherwise specified or unless doing so would render the method or process unsuitable for its intended purpose. Additionally, the elements, steps, members, components, compositions, reactants, parts or portions of any invention or example described herein may optionally exist or be utilized in the absence or substantial absence of any other element, step, member, component, composition, reactant, part or portion unless otherwise noted. All reasonable additions, deletions, modifications and alterations are to be considered equivalents of the described examples and embodiments and are to be included within the scope of the following claims.

What is claimed is:

1. An electronic light emitting flare comprising:
  - a housing comprising a top wall, bottom wall and at least one side wall, wherein at least a portion of the side wall is translucent;
  - a plurality of light emitters positioned within the housing;
  - a power source; and
  - electronic circuitry connected to the power source and light emitters to drive at least some of the light emitters to emit flashes of light directed through all or translucent portions of the housing side wall.
2. A flare according to claim 1 wherein the electronic circuitry is adapted to cause the flare to synchronize the timing of its emission of light with that of neighboring flares in a group or array of said flares.
3. A flare according to claim 2 wherein the electronic circuitry is adapted to employ a mesh network or flocking protocol to synchronize its emission of light with that of neighboring flares in a group or array of said flares.
4. A flare according to claim 1 wherein the electronic circuitry comprises a motion or percussion sensor and causes

the flare to turn on or off in response to motion or percussion sensed by the motion or percussion sensor.

5. A flare according to claim 4 wherein the motion or percussion sensor is selected from motion sensors, percussion sensors, accelerometers, tilt sensors, gyroscopes and micro electrical mechanical systems.

6. A flare according to claim 1 wherein the electronic circuitry is adapted to communicate with other flares in a group or array such that turning on or off of one flare in the group or array causes likewise turning on or off of other flares in the group or array.

7. A flare according to claim 1 at least a portion of the top wall is also translucent and wherein the electronic circuitry alternately drives at least some of the light emitters to emit flashes of light directed through translucent portions of the top wall.

8. A flare according to claim 2 wherein the electronic circuitry comprises switching circuitry to switch back and forth between:

a side emitting mode wherein light emitters emit flashes of light directed through all or translucent portions of the housing side wall; and

a top emitting mode wherein light emitters emit flashes of light directed through translucent portions of the top wall.

9. A flare according to claim 8 wherein the switching circuitry comprises a motion activated switching apparatus which causes switching between the side emitting mode and the top emitting mode in response to certain movements of the flare.

10. A flare according to claim 9 wherein the motion activated switching apparatus causes dynamic LED orientation such that the flare switches back and forth between the first and second modes as the flare is moved back and forth between a horizontal orientation and a vertical orientation.

11. A flare according to claim 10 further comprising one or more magnets for magnetically attaching the flare to a ferromagnetic member.

12. (canceled)

13. A flare according to claim 10 wherein the electronic circuitry includes a locking function which overrides the dynamic LED orientation.

14. (canceled)

15. (canceled)

16. A system comprising a flare according to claim 1 in combination with a traffic cone or other traffic marking or channelizing device that is positionable on the ground or road

surface over top of the flare such that flashes of light emitted out of the translucent portions of the top wall of the flare will illuminate the cone or other traffic marking or channelizing device.

17. A flare according to claim 1 further comprising an on/off button and a utility button, the on/off button being useable to turn the flare on and off and the utility button being useable to trigger the flare to perform certain function.

18. A flare according to claim 1 wherein side emitting LEDs emit light through the side wall when the flare is operating in the side-emitting mode and wherein the side emitting LEDs are angled upwardly from horizontal.

19. (canceled)

20. A system comprising a plurality of flares according to claim 1.

21. A system according to claim 20 wherein the flares communicate such that when an on/off switch of one of the flares is turned on, all of the other flares will also turn on.

22. A system according to claim 21 wherein the flares further communicate such that when an on/off switch on one of the flares is turned off, all of the other flares will also turn off.

23. A system according to claim 22 further comprising a carrying case which is at least partially translucent such that placement of the flares within the carrying case while the flares are turned on will cause light to be emitted from the carrying case.

24. A system according to claim 20 wherein the electronic circuitry is programmed to cause the flares to flash according to a selected flashing pattern that has been selected from a plurality of flashing patterns.

25. A system according to claim 24 wherein the available flashing patterns comprise a) a bright, slow and smooth pattern, b) pairs of flares flashing in a series, c) two flares flashing separated by a non-flashing flare and a tail-off flash pattern.

26. A flare according to claim 1 wherein the electronic circuitry is adapted to receive control signals from a remote control devices in addition to communication from neighboring flares.

27. A system comprising a plurality of flares according to claim 26 in combination with a remote control device.

28. A system according to claim 27 wherein the remote control devices is selected from: a smart phone, cellular communication, infra-red controller, dedicated unit or computer.

29. (canceled)

\* \* \* \* \*