

(19) World Intellectual Property Organization
International Bureau



(43) International Publication Date
4 August 2011 (04.08.2011)

(10) International Publication Number
WO 2011/094086 A1

PCT

(51) International Patent Classification:
F02B 25/06 (2006.01)

(71) Applicant (for US only): **HECKEL, Patricia, E.** (heiress of the deceased inventor) [US/US]; 517 Berry Street, Stoughton, WI 53589 (US).

(21) International Application Number:
PCT/US2011/021495

(72) Inventor: **HECKEL, Scott, P.** (deceased).

(22) International Filing Date:
18 January 2011 (18.01.2011)

(72) Inventors; and

(75) Inventors/Applicants (for US only): **SCHWANDT, Brian, W.** [US/US]; W6621 Grogan Road, Fort Atkinson, WI 53538 (US). **VERDEGAN, Barry, M.** [US/US]; 606 Christiansen Way, Stoughton, WI 53589 (US). **TEWS, Howard, E.** [US/US]; 3502 W. Finley Road, Beloit, WI 53511 (US). **ZOCH, Roger, L.** [US/US]; 3961 Ruth Court, McFarland, WI 53558 (US). **FENG, Shiming** [US/US]; 83 South Gardens Way, Fitchburg, WI 53711 (US).

(25) Filing Language: English

(26) Publication Language: English

(30) Priority Data:
61/298,635 27 January 2010 (27.01.2010) US
61/298,630 27 January 2010 (27.01.2010) US
61/359,192 28 June 2010 (28.06.2010) US
61/383,787 17 September 2010 (17.09.2010) US
61/383,793 17 September 2010 (17.09.2010) US
61/383,790 17 September 2010 (17.09.2010) US
12/969,755 16 December 2010 (16.12.2010) US

(74) Agents: **TAKEN, Michael, E.** et al.; Andrus, Sceales, Starke & Sawall, LLP, 100 East Wisconsin Avenue, Suite 1100, Milwaukee, WI 53202 (US).

(71) Applicant (for all designated States except US): **CUMMINS FILTRATION IP INC.** [US/US]; 1400 - 73rd Avenue NE, Minneapolis, MN 55432 (US).

(81) Designated States (unless otherwise indicated, for every kind of national protection available): AE, AG, AL, AM, AO, AT, AU, AZ, BA, BB, BG, BH, BR, BW, BY, BZ, CA, CH, CL, CN, CO, CR, CU, CZ, DE, DK, DM, DO, DZ, EC, EE, EG, ES, FI, GB, GD, GE, GH, GM, GT, HN, HR, HU, ID, IL, IN, IS, JP, KE, KG, KM, KN, KP, KR, KZ, LA, LC, LK, LR, LS, LT, LU, LY, MA, MD,

[Continued on next page]

(54) Title: CLOSED CRANKCASE VENTILATION SYSTEM

(57) Abstract: A closed crankcase ventilation system for an internal combustion engine includes a return duct with a variably controlled air-oil coalescer. In a turbocharger version, cleaned separated air is provided to the turbocharger inlet, and the coalescer is variably controlled according to a given condition of the turbocharger and/or the engine and/or the coalescer.

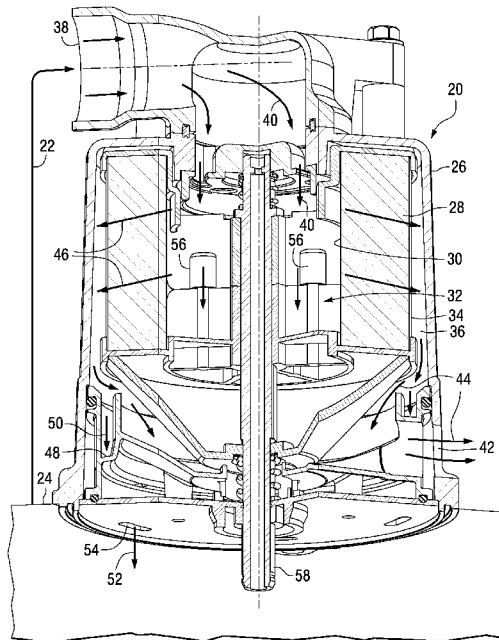

FIG. 1

WO 2011/094086 A1



ME, MG, MK, MN, MW, MX, MY, MZ, NA, NG, NI, NO, NZ, OM, PE, PG, PH, PL, PT, RO, RS, RU, SC, SD, SE, SG, SK, SL, SM, ST, SV, SY, TH, TJ, TM, TN, TR, TT, TZ, UA, UG, US, UZ, VC, VN, ZA, ZM, ZW.

TM), European (AL, AT, BE, BG, CH, CY, CZ, DE, DK, EE, ES, FI, FR, GB, GR, HR, HU, IE, IS, IT, LT, LU, LV, MC, MK, MT, NL, NO, PL, PT, RO, RS, SE, SI, SK, SM, TR), OAPI (BF, BJ, CF, CG, CI, CM, GA, GN, GQ, GW, ML, MR, NE, SN, TD, TG).

(84) Designated States *(unless otherwise indicated, for every kind of regional protection available):* ARIPO (BW, GH, GM, KE, LR, LS, MW, MZ, NA, SD, SL, SZ, TZ, UG, ZM, ZW), Eurasian (AM, AZ, BY, KG, KZ, MD, RU, TJ,

Published:

— *with international search report (Art. 21(3))*

CLOSED CRANKCASE VENTILATION SYSTEM

CROSS-REFERENCE TO RELATED APPLICATIONS

[0001] The present application claims the benefit of and priority from Provisional U.S. Patent Application No. 61/298,630, filed January 27, 2010, Provisional U.S. Patent Application No. 61/298,635, filed January 27, 2010, Provisional U.S. Patent Application No. 61/359,192, filed June 28, 2010, Provisional U.S. Patent Application No. 61/383,787, filed September 17, 2010, U.S. Patent Provisional Patent Application No. 61/383,790, filed September 17, 2010, and Provisional U.S. Patent Application No. 61/383,793, filed September 17, 2010, all incorporated herein by reference.

BACKGROUND AND SUMMARY

[0002] The invention relates to internal combustion engine crankcase ventilation separators, particularly coalescers.

[0003] Internal combustion engine crankcase ventilation separators are known in the prior art. One type of separator uses inertial impaction air-oil separation for removing oil particles from the crankcase blowby gas or aerosol by accelerating the blowby gas stream to high velocities through nozzles or orifices and directing same against an impactor, causing a sharp directional change effecting the oil separation. Another type of separator uses coalescence in a coalescing filter for removing oil droplets.

[0004] The present invention arose during continuing development efforts in the latter noted air-oil separation technology, namely removal of oil from the crankcase blowby gas stream by coalescence using a coalescing filter.

BRIEF DESCRIPTION OF THE DRAWINGS

- [0005] Fig. 1 is a sectional view of a coalescing filter assembly.
- [0006] Fig. 2 is a sectional view of another coalescing filter assembly.
- [0007] Fig. 3 is like Fig. 2 and shows another embodiment.
- [0008] Fig. 4 is a sectional view of another coalescing filter assembly.
- [0009] Fig. 5 is a schematic view illustrating operation of the assembly of Fig. 4.
- [0010] Fig. 6 is a schematic system diagram illustrating an engine intake system.

- [0011] Fig. 7 is a schematic diagram illustrating a control option for the system of Fig. 6.
- [0012] Fig. 8 is a flow diagram illustrating an operational control for the system of Fig. 6.
- [0013] Fig. 9 is like Fig. 8 and shows another embodiment.
- [0014] Fig. 10 is a schematic sectional view show a coalescing filter assembly.
- [0015] Fig. 11 is an enlarged view of a portion of Fig. 10.
- [0016] Fig. 12 is a schematic sectional view of a coalescing filter assembly.
- [0017] Fig. 13 is a schematic sectional view of a coalescing filter assembly.
- [0018] Fig. 14 is a schematic sectional view of a coalescing filter assembly.
- [0019] Fig. 15 is a schematic sectional view of a coalescing filter assembly.
- [0020] Fig. 16 is a schematic sectional view of a coalescing filter assembly.
- [0021] Fig. 17 is a schematic view of a coalescing filter assembly.
- [0022] Fig. 18 is a schematic sectional view of a coalescing filter assembly.
- [0023] Fig. 19 is a schematic diagram illustrating a control system.
- [0024] Fig. 20 is a schematic diagram illustrating a control system.
- [0025] Fig. 21 is a schematic diagram illustrating a control system.

DETAILED DESCRIPTION

[0026] The present application shares a common specification with commonly owned co-pending U.S. Patent Application No. 12/969,742, Attorney Docket 4191-00679, filed on even date herewith, and incorporated herein.

[0027] Fig. 1 shows an internal combustion engine crankcase ventilation rotating coalescer 20 separating air from oil in blowby gas 22 from engine crankcase 24. A coalescing filter assembly 26 includes an annular rotating coalescing filter element 28 having an inner periphery 30 defining a hollow interior 32, and an outer periphery 34 defining an exterior 36. And inlet port 38 supplies blowby gas 22 from crankcase 24 to hollow interior 32 as shown at arrows 40. An outlet port 42 delivers cleaned separated air from the noted exterior zone 36 as shown at arrows 44. The direction of blowby gas flow is inside-out, namely radially outwardly from hollow interior 32 to exterior 36 as shown at arrows 46. Oil in the blowby gas is forced radially outwardly from inner periphery 30 by centrifugal force,

to reduce clogging of the coalescing filter element 28 otherwise caused by oil sitting on inner periphery 30. This also opens more area of the coalescing filter element to flow-through, whereby to reduce restriction and pressure drop. Centrifugal force drives oil radially outwardly from inner periphery 30 to outer periphery 34 to clear a greater volume of coalescing filter element 28 open to flow-through, to increase coalescing capacity. Separated oil drains from outer periphery 34. Drain port 48 communicates with exterior 36 and drains separated oil from outer periphery 34 as shown at arrow 50, which oil may then be returned to the engine crankcase as shown at arrow 52 from drain 54.

[0028] Centrifugal force pumps blowby gas from the crankcase to hollow interior 32. The pumping of blowby gas from the crankcase to hollow interior 32 increases with increasing speed of rotation of coalescing filter element 28. The increased pumping of blowby gas 22 from crankcase 24 to hollow interior 32 reduces restriction across coalescing filter element 28. In one embodiment, a set of vanes may be provided in hollow interior 32 as shown in dashed line at 56, enhancing the noted pumping. The noted centrifugal force creates a reduced pressure zone in hollow interior 32, which reduced pressure zone sucks blowby gas 22 from crankcase 24.

[0029] In one embodiment, coalescing filter element 28 is driven to rotate by a mechanical coupling to a component of the engine, e.g. axially extending shaft 58 connected to a gear or drive pulley of the engine. In another embodiment, coalescing filter element 28 is driven to rotate by a fluid motor, e.g. a pelton or turbine drive wheel 60, Fig. 2, driven by pumped pressurized oil from the engine oil pump 62 and returning same to engine crankcase sump 64. Fig. 2 uses like reference numerals from Fig. 1 where appropriate to facilitate understanding. Separated cleaned air is supplied through pressure responsive valve 66 to outlet 68 which is an alternate outlet to that shown at 42 in Fig. 1. In another embodiment, coalescing filter element 28 is driven to rotate by an electric motor 70, Fig. 3, having a drive output rotary shaft 72 coupled to shaft 58. In another embodiment, coalescing filter element 28 is driven to rotate by magnetic coupling to a component of the engine, Figs. 4, 5. An engine driven rotating gear 74 has a plurality of magnets such as 76 spaced around the periphery thereof and magnetically coupling to a plurality of magnets 78 spaced around inner periphery 30 of the coalescing filter element such that as gear or driving wheel 74 rotates, magnets 76 move past, Fig. 5, and magnetically couple with magnets 78, to in turn rotate the

coalescing filter element as a driven member. In Fig. 4, separated cleaned air flows from exterior zone 36 through channel 80 to outlet 82, which is an alternate cleaned air outlet to that shown at 42 in Fig. 1. The arrangement in Fig. 5 provides a gearing-up effect to rotate the coalescing filter assembly at a greater rotational speed (higher angular velocity) than driving gear or wheel 74, e.g. where it is desired to provide a higher rotational speed of the coalescing filter element.

[0030] Pressure drop across coalescing filter element 28 decreases with increasing rotational speed of the coalescing filter element. Oil saturation of coalescing filter element 28 decreases with increasing rotational speed of the coalescing filter element. Oil drains from outer periphery 34, and the amount of oil drained increases with increasing rotational speed of coalescing filter element 28. Oil particle settling velocity in coalescing filter element 28 acts in the same direction as the direction of air flow through the coalescing filter element. The noted same direction enhances capture and coalescence of oil particles by the coalescing filter element.

[0031] The present system provides a method for separating air from oil in internal combustion engine crankcase ventilation blowby gas by introducing a G force in coalescing filter element 28 to cause increased gravitational settling in the coalescing filter element, to improve particle capture and coalescence of submicron oil particles by the coalescing filter element. The method includes providing an annular coalescing filter element 28, rotating the coalescing filter element, and providing inside-out flow through the rotating coalescing filter element.

[0032] The system provides a method for reducing crankcase pressure in an internal combustion engine crankcase generating blowby gas. The method includes providing a crankcase ventilation system including a coalescing filter element 28 separating air from oil in the blowby gas, providing the coalescing filter element as an annular element having a hollow interior 32, supplying the blowby gas to the hollow interior, and rotating the coalescing filter element to pump blowby gas out of crankcase 24 and into hollow interior 32 due to centrifugal force forcing the blowby gas to flow radially outwardly as shown at arrows 46 through coalescing filter element 28, which pumping effects reduced pressure in crankcase 24.

[0033] One type of internal combustion engine crankcase ventilation system

provides open crankcase ventilation (OCV), wherein the cleaned air separated from the blowby gas is discharged to the atmosphere. Another type of internal combustion crankcase ventilation system involves closed crankcase ventilation (CCV), wherein the cleaned air separated from the blowby gas is returned to the engine, e.g. is returned to the combustion air intake system to be mixed with the incoming combustion air supplied to the engine.

[0034] Fig. 6 shows a closed crankcase ventilation (CCV) system 100 for an internal combustion engine 102 generating blowby gas 104 in a crankcase 106. The system includes an air intake duct 108 supplying combustion air to the engine, and a return duct 110 having a first segment 112 supplying the blowby gas from the crankcase to air-oil coalescer 114 to clean the blowby gas by coalescing oil therefrom and outputting cleaned air at output 116, which may be outlet 42 of Fig. 1, 68 of Fig. 2, 82 of Fig. 4. Return duct 110 includes a second segment 118 supplying the cleaned air from coalescer 114 to air intake duct 108 to join the combustion air being supplied to the engine. Coalescer 114 is variably controlled according to a given condition of the engine, to be described.

[0035] Coalescer 114 has a variable efficiency variably controlled according to a given condition of the engine. In one embodiment, coalescer 114 is a rotating coalescer, as above, and the speed of rotation of the coalescer is varied according to the given condition of the engine. In one embodiment, the given condition is engine speed. In one embodiment, the coalescer is driven to rotate by an electric motor, e.g. 70, Fig. 3. In one embodiment, the electric motor is a variable speed electric motor to vary the speed of rotation of the coalescer. In another embodiment, the coalescer is hydraulically driven to rotate, e.g. Fig. 2. In one embodiment, the speed of rotation of the coalescer is hydraulically varied. In this embodiment, the engine oil pump 62, Figs. 2, 7, supplies pressurized oil through a plurality of parallel shut-off valves such as 120, 122, 124 which are controlled between closed and open or partially open states by the electronic control module (ECM) 126 of the engine, for flow through respective parallel orifices or nozzles 128, 130, 132 to controllably increase or decrease the amount of pressurized oil supplied against pelton or turbine wheel 60, to in turn controllably vary the speed of rotation of shaft 58 and coalescing filter element 28.

[0036] In one embodiment, a turbocharger system 140, Fig. 6, is provided for the internal combustion 102 generating blowby gas 104 in crankcase 106. The system includes the noted air intake duct 108 having a first segment 142 supplying combustion air to a

turbocharger 144, and a second segment 146 supplying turbocharged combustion air from turbocharger 144 to engine 102. Return duct 110 has the noted first segment 112 supplying the blowby gas 104 from crankcase 106 to air-oil coalescer 114 to clean the blowby gas by coalescing oil therefrom and outputting cleaned air at 116. The return duct has the noted second segment 118 supplying cleaned air from coalescer 114 to first segment 142 of air intake duct 108 to join combustion air supplied to turbocharger 144. Coalescer 114 is variably controlled according to a given condition of at least one of turbocharger 144 and engine 102. In one embodiment, the given condition is a condition of the turbocharger. In a further embodiment, the coalescer is a rotating coalescer, as above, and the speed of rotation of the coalescer is varied according to turbocharger efficiency. In a further embodiment, the speed of rotation of the coalescer is varied according to turbocharger boost pressure. In a further embodiment, the speed of rotation of the coalescer is varied according to turbocharger boost ratio, which is the ratio of pressure at the turbocharger outlet versus pressure at the turbocharger inlet. In a further embodiment, the coalescer is driven to rotate by an electric motor, e.g. 70, Fig. 3. In a further embodiment, the electric motor is a variable speed electric motor to vary the speed of rotation of the coalescer. In another embodiment, the coalescer is hydraulically driven to rotate, Fig. 2. In a further embodiment, the speed of rotation of the coalescer is hydraulically varied, Fig. 7.

[0037] The system provides a method for improving turbocharger efficiency in a turbocharger system 140 for an internal combustion engine 102 generating blowby gas 104 in a crankcase 106, the system having an air intake duct 108 having a first segment 142 supplying combustion air to a turbocharger 144, and a second segment 146 supplying turbocharged combustion air from the turbocharger 144 to the engine 102, and having a return duct 110 having a first segment 112 supplying the blowby gas 104 to air-oil coalescer 114 to clean the blowby gas by coalescing oil therefrom and outputting cleaned air at 116, the return duct having a second segment 118 supplying the cleaned air from the coalescer 114 to the first segment 142 of the air intake duct to join combustion air supplied to turbocharger 144. The method includes variably controlling coalescer 114 according to a given condition of at least one of turbocharger 144 and engine 102. One embodiment variably controls coalescer 114 according to a given condition of turbocharger 144. A further embodiment provides the coalescer as a rotating coalescer, as above, and varies the

speed of rotation of the coalescer according to turbocharger efficiency. A further method varies the speed of rotation of coalescer 114 according to turbocharger boost pressure. A further embodiment varies the speed of rotation of coalescer 114 according to turbocharger boost ratio, which is the ratio of pressure at the turbocharger outlet versus pressure at the turbocharger inlet.

[0038] Fig. 8 shows a control scheme for CCV implementation. At step 160, turbocharger efficiency is monitored, and if the turbo efficiency is ok as determined at step 162, then rotor speed of the coalescing filter element is reduced at step 164. If the turbocharger efficiency is not ok, then engine duty cycle is checked at step 166, and if the engine duty cycle is severe then rotor speed is increased at step 168, and if engine duty cycle is not severe then no action is taken as shown at step 170.

[0039] Fig. 9 shows a control scheme for OCV implementation. Crankcase pressure is monitored at step 172, and if it is ok as determined at step 174 then rotor speed is reduced at step 176, and if not ok then ambient temperature is checked at step 178 and if less than 0° C, then at step 180 rotor speed is increased to a maximum to increase warm gas pumping and increase oil-water slinging. If ambient temperature is not less than 0° C, then engine idling is checked at step 182, and if the engine is idling then at step 184 rotor speed is increased and maintained, and if the engine is not idling, then at step 186 rotor speed is increased to a maximum for five minutes.

[0040] The flow path through the coalescing filter assembly is from upstream to downstream, e.g. in Fig. 1 from inlet port 38 to outlet port 42, e.g. in Fig. 2 from inlet port 38 to outlet port 68, e.g. in Fig. 10 from inlet port 190 to outlet port 192. There is further provided in Fig. 10 in combination a rotary cone stack separator 194 located in the flow path and separating air from oil in the blowby gas. Cone stack separators are known in the prior art. The direction of blowby gas flow through the rotating cone stack separator is inside-out, as shown at arrows 196, Figs. 10-12. Rotating cone stack separator 194 is upstream of rotating coalescer filter element 198. Rotating cone stack separator 194 is in hollow interior 200 of rotating coalescer filter element 198. In Fig. 12, an annular shroud 202 is provided in hollow interior 200 and is located radially between rotating cone stack separator 194 and rotating coalescer filter element 198 such that shroud 202 is downstream of rotating cone stack separator 194 and upstream of rotating coalescer filter element 198

and such that shroud 202 provides a collection and drain surface 204 along which separated oil drains after separation by the rotating cone stack separator, which oil drains as shown at droplet 206 through drain hole 208, which oil then joins the oil separated by coalescer 198 as shown at 210 and drains through main drain 212.

[0041] Fig. 13 shows a further embodiment and uses like reference numerals from above where appropriate to facilitate understanding. Rotating cone stack separator 214 is downstream of rotating coalescer filter element 198. The direction of flow through rotating cone stack separator 214 is inside-out. Rotating cone stack separator 214 is located radially outwardly of and circumscribes rotating coalescer filter element 198.

[0042] Fig. 14 shows another embodiment and uses like reference numerals from above where appropriate to facilitate understanding. Rotating cone stack separator 216 is downstream of rotating coalescer filter element 198. The direction of flow through rotating cone stack separator 216 is outside-in, as shown at arrows 218. Rotating coalescer filter element 198 and rotating cone stack separator 216 rotate about a common axis 220 and are axially adjacent each other. Blowby gas flows radially outwardly through rotating coalescer filter element 198 as shown at arrows 222 then axially as shown at arrows 224 to rotating cone stack separator 216 then radially inwardly as shown at arrows 218 through rotating cone stack separator 216.

[0043] Fig. 15 shows another embodiment and uses like reference numerals from above where appropriate to facilitate understanding. A second annular rotating coalescer filter element 230 is provided in the noted flow path from inlet 190 to outlet 192 and separates air from oil in the blowby gas. The direction of flow through second rotating coalescer filter element 230 is outside-in as shown at arrow 232. Second rotating coalescer filter element 230 is downstream of first rotating coalescer element 198. First and second rotating coalescer filter elements 198 and 230 rotate about a common axis 234 and are axially adjacent each other. Blowby gas flows radially outwardly as shown at arrow 222 through first rotating coalescer filter element 198 then axially as shown at arrow 236 to second rotating coalescer filter element 230 then radially inwardly as shown at arrow 232 through second rotating coalescer filter element 230.

[0044] In various embodiments, the rotating cone stack separator may be perforated with a plurality of drain holes, e.g. 238, Fig. 13, allowing drainage therethrough

of separated oil.

[0045] Fig. 16 shows another embodiment and uses like reference numerals from above where appropriate to facilitate understanding. An annular shroud 240 is provided along the exterior 242 of rotating coalescer filter element 198 and radially outwardly thereof and downstream thereof such that shroud 240 provides a collection and drain surface 244 along which separated oil drains as shown at droplets 246 after coalescence by rotating coalescer filter element 198. Shroud 240 is a rotating shroud and may be part of the filter frame or end cap 248. Shroud 240 circumscribes rotating coalescer filter element 198 and rotates about a common axis 250 therewith. Shroud 240 is conical and tapers along a conical taper relative to the noted axis. Shroud 240 has an inner surface at 244 radially facing rotating coalescer filter element 198 and spaced therefrom by a radial gap 252 which increases as the shroud extends axially downwardly and along the noted conical taper. Inner surface 244 may have ribs such as 254, Fig. 17, circumferentially spaced therearound and extending axially and along the noted conical taper and facing rotating coalescer filter element 198 and providing channeled drain paths such as 256 therealong guiding and draining separated oil flow therealong. Inner surface 244 extends axially downwardly along the noted conical taper from a first upper axial end 258 to a second lower axial end 260. Second axial end 260 is radially spaced from rotating coalescer filter element 198 by a radial gap greater than the radial spacing of first axial end 258 from rotating coalescer filter element 198. In a further embodiment, second axial end 260 has a scalloped lower edge 262, also focusing and guiding oil drainage.

[0046] Fig. 18 shows a further embodiment and uses like reference numerals from above where appropriate to facilitate understanding. In lieu of lower inlet 190, Figs. 13-15, an upper inlet port 270 is provided, and a pair of possible or alternate outlet ports are shown at 272 and 274. Oil drainage through drain 212 may be provided through a one-way check valve such as 276 to drain hose 278, for return to the engine crankcase, as above.

[0047] As above noted, the coalescer can be variably controlled according to a given condition, which may be a given condition of at least one of the engine, the turbocharger, and the coalescer. In one embodiment, the noted given condition is a given condition of the engine, as above noted. In another embodiment, the given condition is a

given condition of the turbocharger, as above noted. In another embodiment, the given condition is a given condition of the coalescer. In a version of this embodiment, the noted given condition is pressure drop across the coalescer. In a version of this embodiment, the coalescer is a rotating coalescer, as above, and is driven at higher rotational speed when pressure drop across the coalescer is above a predetermined threshold, to prevent accumulation of oil on the coalescer, e.g. along the inner periphery thereof in the noted hollow interior, and to lower the noted pressure drop. Fig. 19 shows a control scheme wherein the pressure drop, dP , across the rotating coalescer is sensed, and monitored by the ECM (engine control module), at step 290, and then it is determined at step 292 whether dP is above a certain value at low engine RPM, and if not, then rotational speed of the coalescer is kept the same at step 294, and if dP is above a certain value then the coalescer is rotated at a higher speed at step 296 until dP drops down to a certain point. The noted given condition is pressure drop across the coalescer, and the noted predetermined threshold is a predetermined pressure drop threshold.

[0048] In a further embodiment, the coalescer is an intermittently rotating coalescer having two modes of operation, and is in a first stationary mode when a given condition is below a predetermined threshold, and is in a second rotating mode when the given condition is above the predetermined threshold, with hysteresis if desired. The first stationary mode provides energy efficiency and reduction of parasitic energy loss. The second rotating mode provides enhanced separation efficiency removing oil from the air in the blowby gas. In one embodiment, the given condition is engine speed, and the predetermined threshold is a predetermined engine speed threshold. In another embodiment, the given condition is pressure drop across the coalescer, and the predetermined threshold is a predetermined pressure drop threshold. In another embodiment, the given condition is turbocharger efficiency, and the predetermined threshold is a predetermined turbocharger efficiency threshold. In a further version, the given condition is turbocharger boost pressure, and the predetermined threshold is a predetermined turbocharger boost pressure threshold. In a further version, the given condition is turbocharger boost ratio, and the predetermined threshold is a predetermined turbocharger boost ratio threshold, where, as above noted, turbocharger boost ratio is the ratio of pressure at the turbocharger outlet vs. pressure at the turbocharger inlet. Fig. 20

shows a control scheme for an electrical version wherein engine RPM or coalescer pressure drop is sensed at step 298 and monitored by the ECM at step 300 and then at step 302 if the RPM or pressure is above a threshold then rotation of the coalescer is initiated at step 304, and if the RPM or pressure is not above the threshold then the coalescer is left in the stationary mode at step 306. Fig. 21 shows a mechanical version and uses like reference numerals from above where appropriate to facilitate understanding. A check valve, spring or other mechanical component at step 308 senses RPM or pressure and the decision process is carried out at steps 302, 304, 306 as above.

[0049] The noted method for improving turbocharger efficiency includes variably controlling the coalescer according to a given condition of at least one of the turbocharger, the engine, and the coalescer. One embodiment variably controls the coalescer according to a given condition of the turbocharger. In one version, the coalescer is provided as a rotating coalescer, and the method includes varying the speed of rotation of the coalescer according to turbocharger efficiency, and in another embodiment according to turbocharger boost pressure, and in another embodiment according to turbocharger boost ratio, as above noted. A further embodiment variably controls the coalescer according to a given condition of the engine, and in a further embodiment according to engine speed. In a further version, the coalescer is provided as a rotating coalescer, and the method involves varying the speed of rotation of the coalescer according to engine speed. A further embodiment variably controls the coalescer according to a given condition of the coalescer, and in a further version according to pressure drop across the coalescer. In a further version, the coalescer is provided as a rotating coalescer, and the method involves varying the speed of rotation of the coalescer according to pressure drop across the coalescer. A further embodiment involves intermittently rotating the coalescer to have two modes of operation including a first stationary mode and a second rotating mode, as above.

[0050] In the foregoing description, certain terms have been used for brevity, clearness, and understanding. No unnecessary limitations are to be inferred therefrom beyond the requirement of the prior art because such terms are used for descriptive purposes and are intended to be broadly construed. The different configurations, systems, and method steps described herein may be used alone or in combination with other

configurations, systems and method steps. It is to be expected that various equivalents, alternatives and modifications are possible within the scope of the appended claims. Each limitation in the appended claims is intended to invoke interpretation under 35 U.S.C. §112, sixth paragraph, only if the terms "means for" or "step for" are explicitly recited in the respective limitation.

CLAIMS

What is claimed is:

1. A closed crankcase ventilation system for an internal combustion engine generating blowby gas in a crankcase, comprising an air intake duct supplying combustion air to said engine, a return duct having a first segment supplying said blowby gas from said crankcase to an air-oil coalescer to clean said blowby gas by coalescing oil therefrom and outputting cleaned air, said return duct having a second segment supplying said cleaned air from said coalescer to said air intake duct to join said combustion air being supplied to said engine, said coalescer being variably controlled according to a given condition of at least one of said engine and said coalescer.
2. The closed crankcase ventilation system according to claim 1 wherein said given condition is a given condition of said engine.
3. The closed crankcase ventilation system according to claim 2 wherein said coalescer has a variable efficiency variably controlled according to said given condition of said engine.
4. The closed crankcase ventilation system according to claim 2 wherein said coalescer is a rotating coalescer, and wherein the speed of rotation of said coalescer is varied according to said given condition of said engine.
5. The closed crankcase ventilation system according to claim 4 wherein said given condition is engine speed.
6. The closed crankcase ventilation system according to claim 1 wherein said coalescer is a rotating coalescer driven to rotate by an electric motor.
7. The closed crankcase ventilation system according to claim 6 wherein said electric motor is a variable speed electric motor to vary the speed of rotation of said coalescer.

8. The closed crankcase ventilation system according to claim 1 wherein said coalescer is a rotating coalescer hydraulically driven to rotate.

9. The closed crankcase ventilation system according to claim 8 wherein the speed of rotation of said coalescer is hydraulically varied.

10. The closed crankcase ventilation system according to claim 1 wherein said given condition is a given condition of said coalescer.

11. The closed crankcase ventilation system according to claim 10 wherein said given condition is pressure drop across said coalescer.

12. The closed crankcase ventilation system according to claim 11 wherein said coalescer is a rotating coalescer driven at higher rotational speed when said pressure drop across said coalescer is above a predetermined threshold, to prevent accumulation of oil on said coalescer and to lower said pressure drop.

13. The closed crankcase ventilation system according to claim 1 wherein said coalescer is an intermittently rotating coalescer having two modes of operation, and is in a first stationary mode when said given condition is below a predetermined threshold, and is in a second rotating mode when said given condition is above said predetermined threshold, said first stationary mode providing energy efficiency and reduction of parasitic energy loss, said second rotating mode providing enhanced separation efficiency removing oil from said air in said blowby gas.

14. The closed crankcase ventilation system according to claim 13 wherein said given condition is engine speed, and said predetermined threshold is a predetermined engine speed threshold.

15. The closed crankcase ventilation system according to claim 13

wherein said given condition is pressure drop across said coalescer, and said predetermined threshold is a predetermined pressure drop threshold.

16. A turbocharger system for an internal combustion engine generating blowby gas in a crankcase, comprising an air intake duct having a first segment supplying combustion air to a turbocharger, and a second segment supplying turbocharged combustion air from said turbocharger to said engine, a return duct having a first segment supplying said blowby gas from said crankcase to an air-oil coalescer to clean said blowby gas by coalescing oil therefrom and outputting cleaned air, said return duct having a second segment supplying said cleaned air from said coalescer to said first segment of said air intake duct to join said combustion air supplied to said turbocharger, said coalescer being variably controlled according to a given condition of at least one of said turbocharger, said engine, and said coalescer

17. The turbocharger system according to claim 16 wherein said given condition is a condition of said turbocharger.

18. The turbocharger system according to claim 17 wherein said coalescer is a rotating coalescer, and wherein the speed of rotation of said coalescer is varied according to turbocharger efficiency.

19. The turbocharger system according to claim 17 wherein said coalescer is a rotating coalescer, and wherein the speed of rotation of said coalescer is varied according to turbocharger boost pressure.

20. The turbocharger system according to claim 17 wherein said coalescer is a rotating coalescer, and wherein the speed of rotation of said coalescer is varied according to turbocharger boost ratio, which is the ratio of pressure at the turbocharger outlet versus pressure at the turbocharger inlet.

21. The turbocharger system according to claim 16 wherein said coalescer

is a rotating coalescer driven to rotate by an electric motor.

22. The turbocharger system according to claim 21 wherein said electric motor is a variable speed electric motor to vary the speed of rotation of said coalescer.

23. The turbocharger system according to claim 16 wherein said coalescer is a rotating coalescer hydraulically driven to rotate.

24. The turbocharger system according to claim 23 wherein the speed of rotation of said coalescer is hydraulically varied.

25. The turbocharger system according to claim 16 wherein said given condition is a given condition of said engine.

26. The turbocharger system according to claim 25 wherein said coalescer has a variable efficiency variably controlled according to said given condition of said engine.

27. The turbocharger system according to claim 25 wherein said coalescer is a rotating coalescer, and wherein the speed of rotation of said coalescer is varied according to said given condition of said engine.

28. The turbocharger system according to claim 27 wherein said given condition is engine speed.

29. The turbocharger system according to claim 16 wherein said given condition is a given condition of said coalescer.

30. The turbocharger system according to claim 29 wherein said given condition is pressure drop across said coalescer.

31. The turbocharger system according to claim 30 wherein said coalescer

is a rotating coalescer driven at higher rotational speed when said pressure drop across said coalescer is above a predetermined threshold, to prevent accumulation of oil on said coalescer and to lower said pressure drop.

32. The turbocharger system according to claim 16 wherein said coalescer is an intermittently rotating coalescer having two modes of operation, and is in a first stationary mode when said given condition is below a predetermined threshold, and is in a second rotating mode when said given condition is above said predetermined threshold, said first stationary mode providing energy efficiency and reduction of parasitic energy loss, said second rotating mode providing enhanced separation efficiency removing oil from said air in said blowby gas.

33. The turbocharger system according to claim 32 wherein said given condition is engine speed, and said predetermined threshold is a predetermined engine speed threshold.

34. The turbocharger system according to claim 32 wherein said given condition is pressure drop across said coalescer, and said predetermined threshold is a predetermined pressure drop threshold.

35. The turbocharger system according to claim 32 wherein said given condition is turbocharger efficiency, and said predetermined threshold is a predetermined turbocharger efficiency threshold.

36. The turbocharger system according to claim 32 wherein said given condition is turbocharger boost pressure, and said predetermined threshold is a predetermined turbocharger boost pressure threshold.

37. The turbocharger system according to claim 32 wherein said given condition is turbocharger boost ratio, and said predetermined threshold is a predetermined turbocharger boost ratio threshold, where turbocharger boost ratio is the ratio of pressure at

the turbocharger outlet vs. pressure at the turbocharger inlet.

38. A method for improving turbocharger efficiency in a turbocharger system for an internal combustion engine generating blowby gas in a crankcase, said system having an air intake duct having a first segment supplying combustion air to a turbocharger, and a second segment supplying turbocharged combustion air from said turbocharger to said engine, a return duct having a first segment supplying said blowby gas from said crankcase to an air-oil coalescer to clean said blowby gas by coalescing oil therefrom and outputting cleaned air, said return duct having a second segment supplying said cleaned air from said coalescer to said first segment of said air intake duct to join said combustion air supplied to said turbocharger, said method comprising variably controlling said coalescer according to a given condition of at least one of said turbocharger, said engine, and said coalescer.

39. The method according to claim 38 comprising variably controlling said coalescer according to a given condition of said turbocharger.

40. The method according to claim 38 comprising providing said coalescer as a rotating coalescer, and varying the speed of rotation of said coalescer according to turbocharger efficiency.

41. The method according to claim 38 comprising providing said coalescer as a rotating coalescer, and varying the speed of rotation of said coalescer according to turbocharger boost pressure.

42. The method according to claim 38 comprising providing said coalescer as a rotating coalescer, and varying the speed of rotation of said coalescer according to turbocharger boost ratio, which is the ratio of pressure at the turbocharger outlet versus pressure at the turbocharger inlet.

43. The method according to claim 38 comprising variably controlling said coalescer according to a given condition of said engine.

44. The method according to claim 43 comprising variably controlling said coalescer according to engine speed.

45. The method according to claim 44 comprising providing said coalescer as a rotating coalescer, and varying the speed of rotation of said coalescer according to engine speed.

46. The method according to claim 38 comprising variably controlling said coalescer according to a given condition of said coalescer.

47. The method according to claim 46 comprising variably controlling said coalescer according to pressure drop across said coalescer.

48. The method according to claim 47 comprising providing said coalescer as a rotating coalescer, and varying the speed of rotation of said coalescer according to pressure drop across said coalescer.

49. The method according to claim 38 comprising intermittently rotating said coalescer to have two modes of operation comprising a first stationary mode when said given condition is below a predetermined threshold, and a second rotating mode when said given condition is above said predetermined threshold, said first stationary mode providing energy efficiency and reduction of parasitic energy loss, said second rotating mode providing enhanced separation efficiency removing oil from said air in said blowby gas.

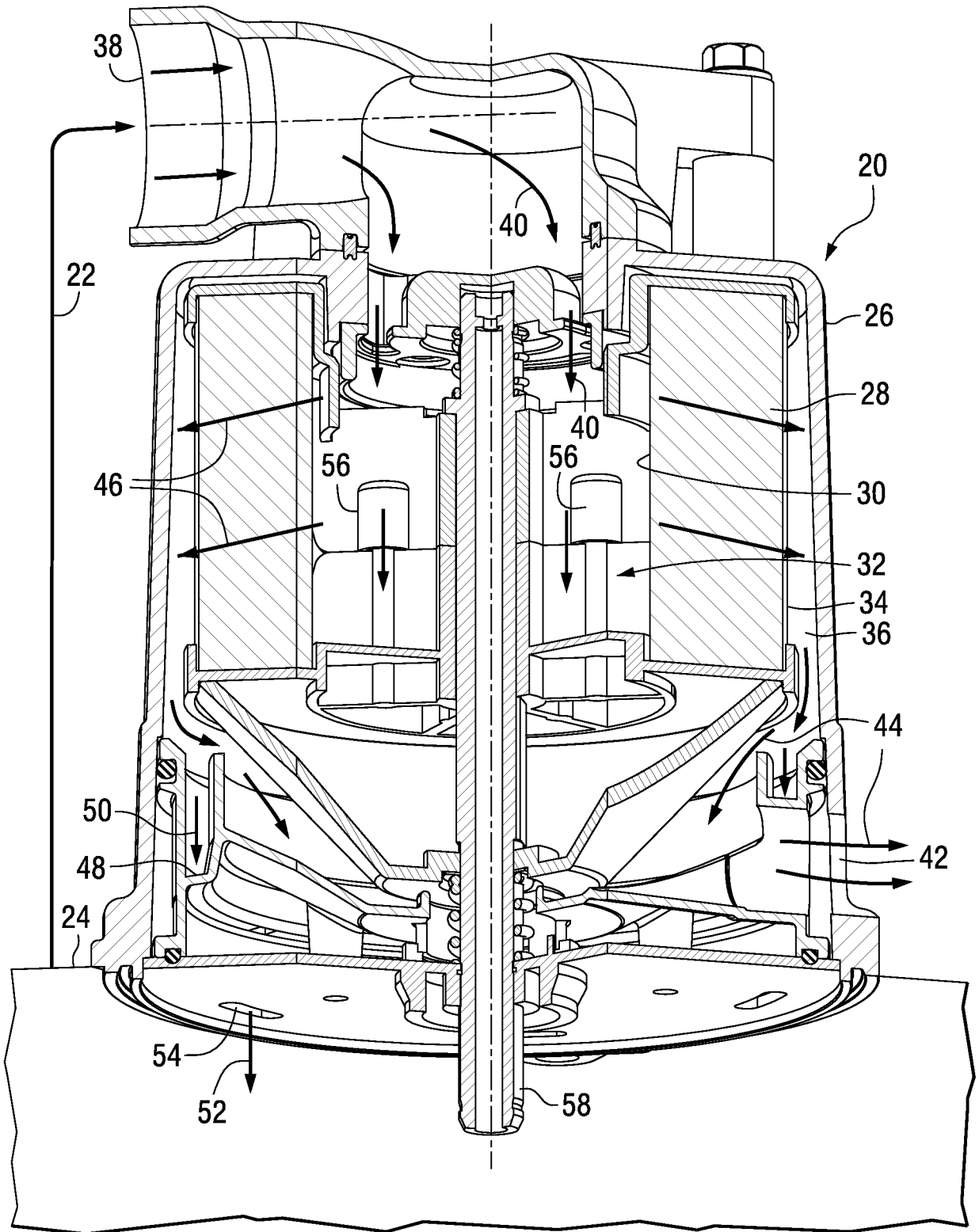

FIG. 1

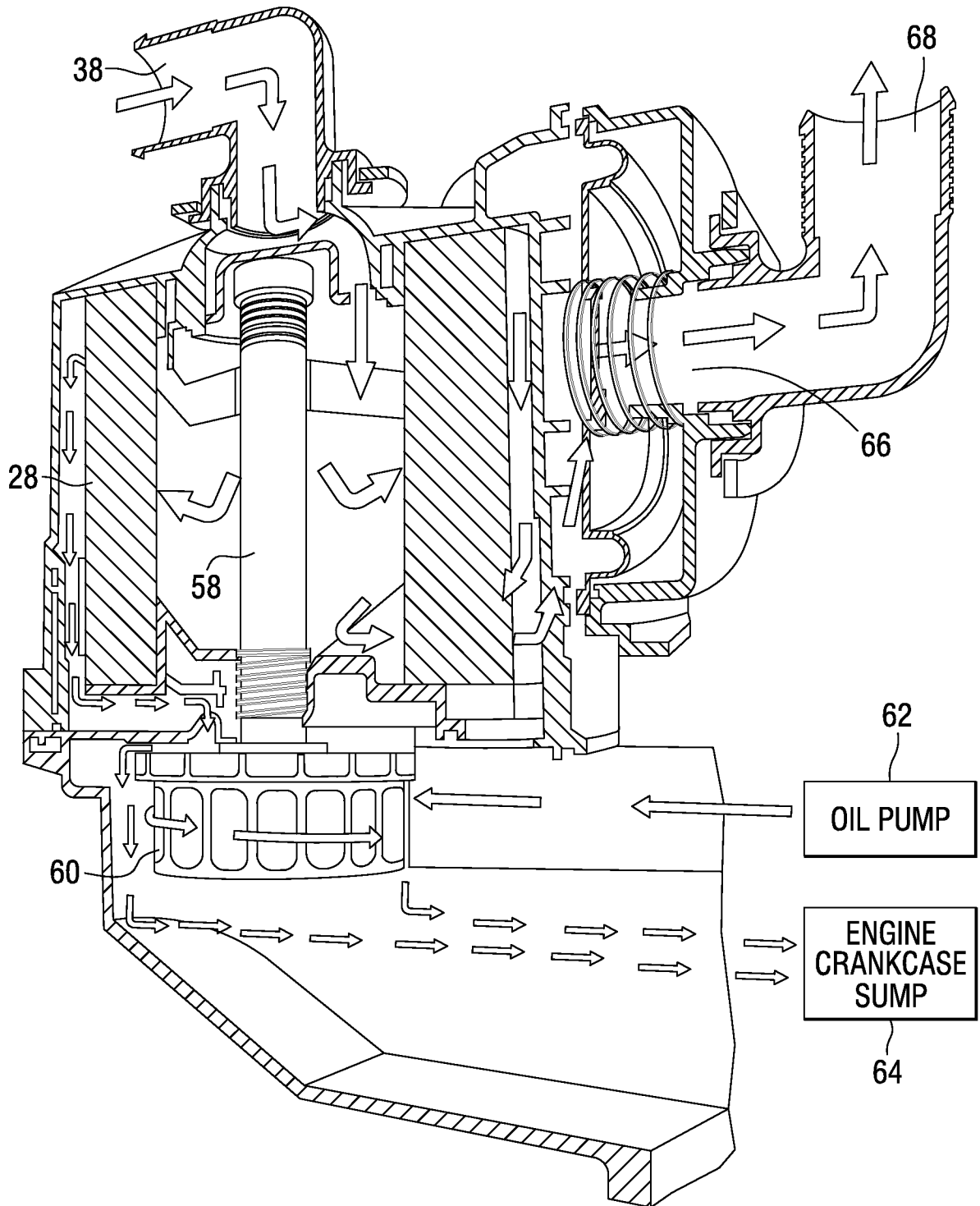

FIG. 2

3/16

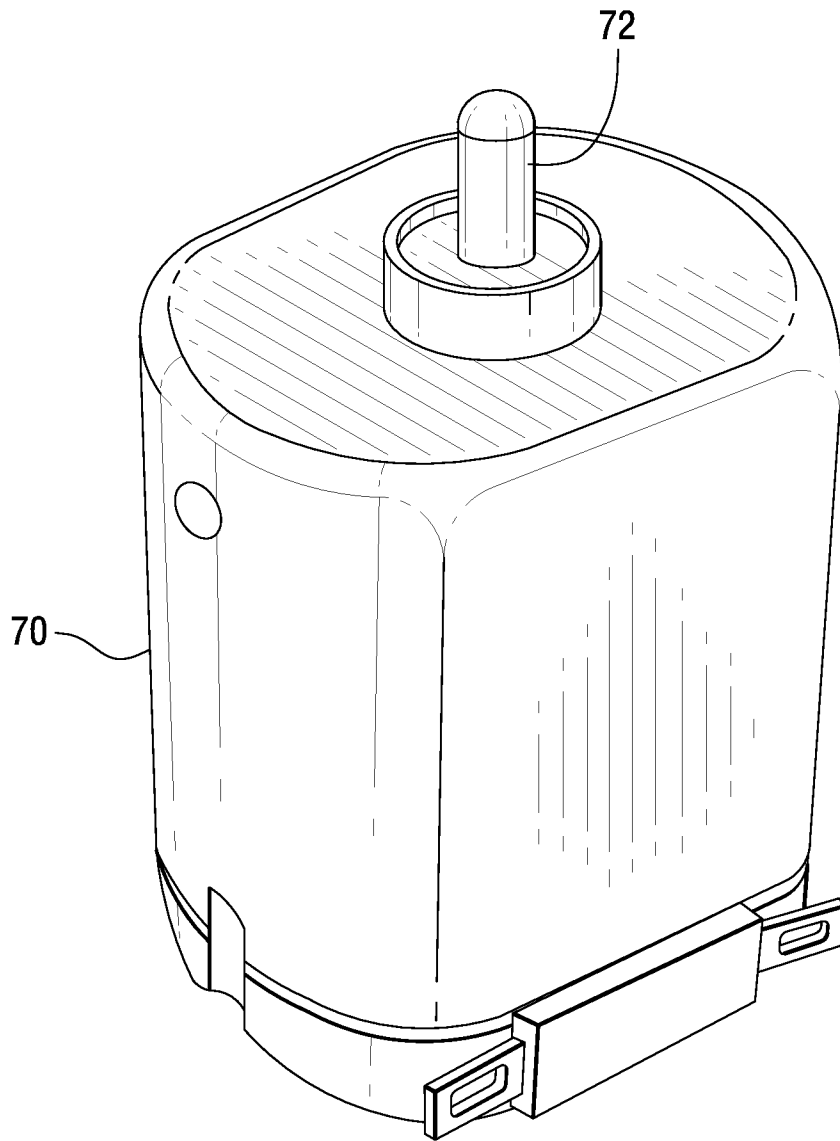

FIG. 3

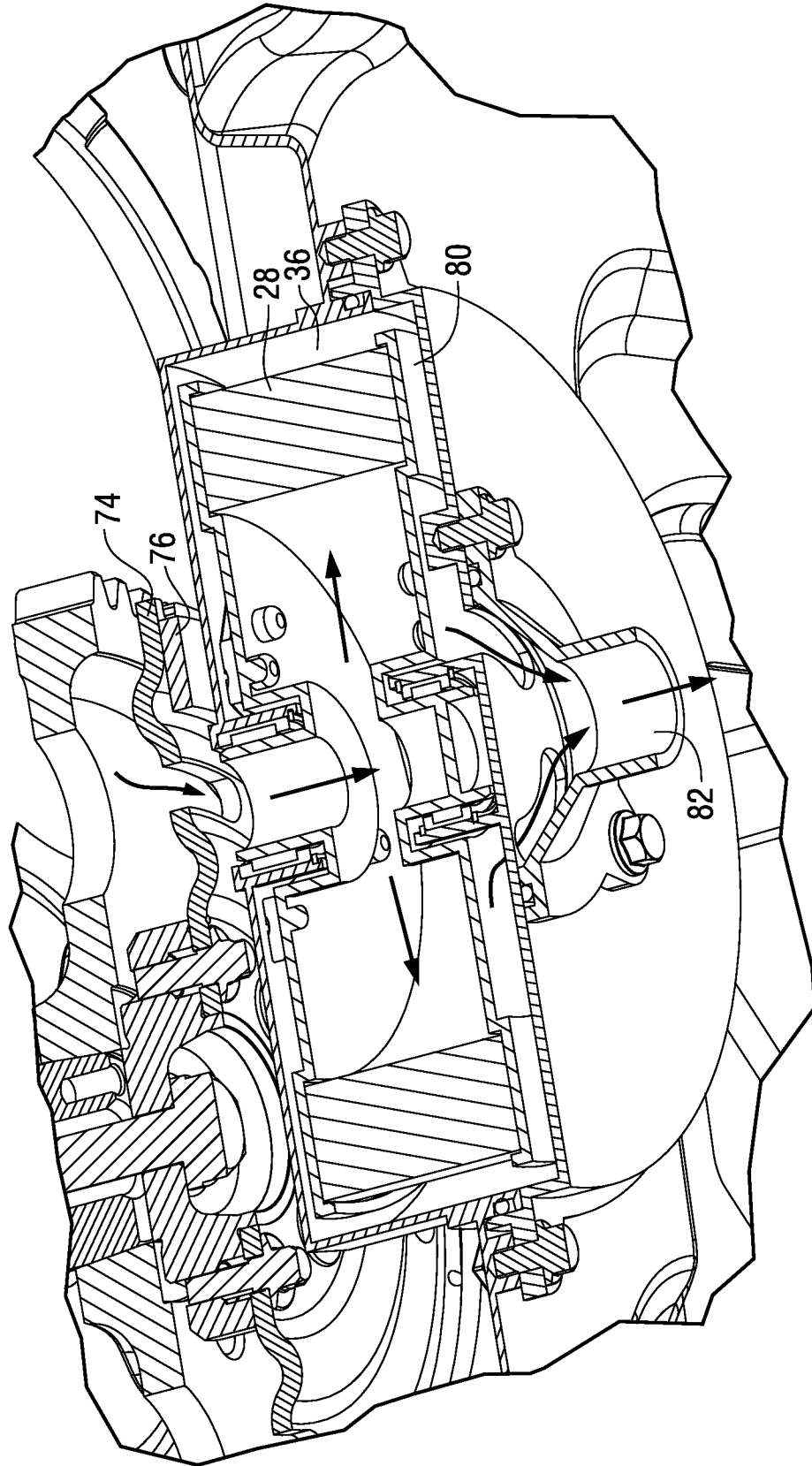

FIG. 4

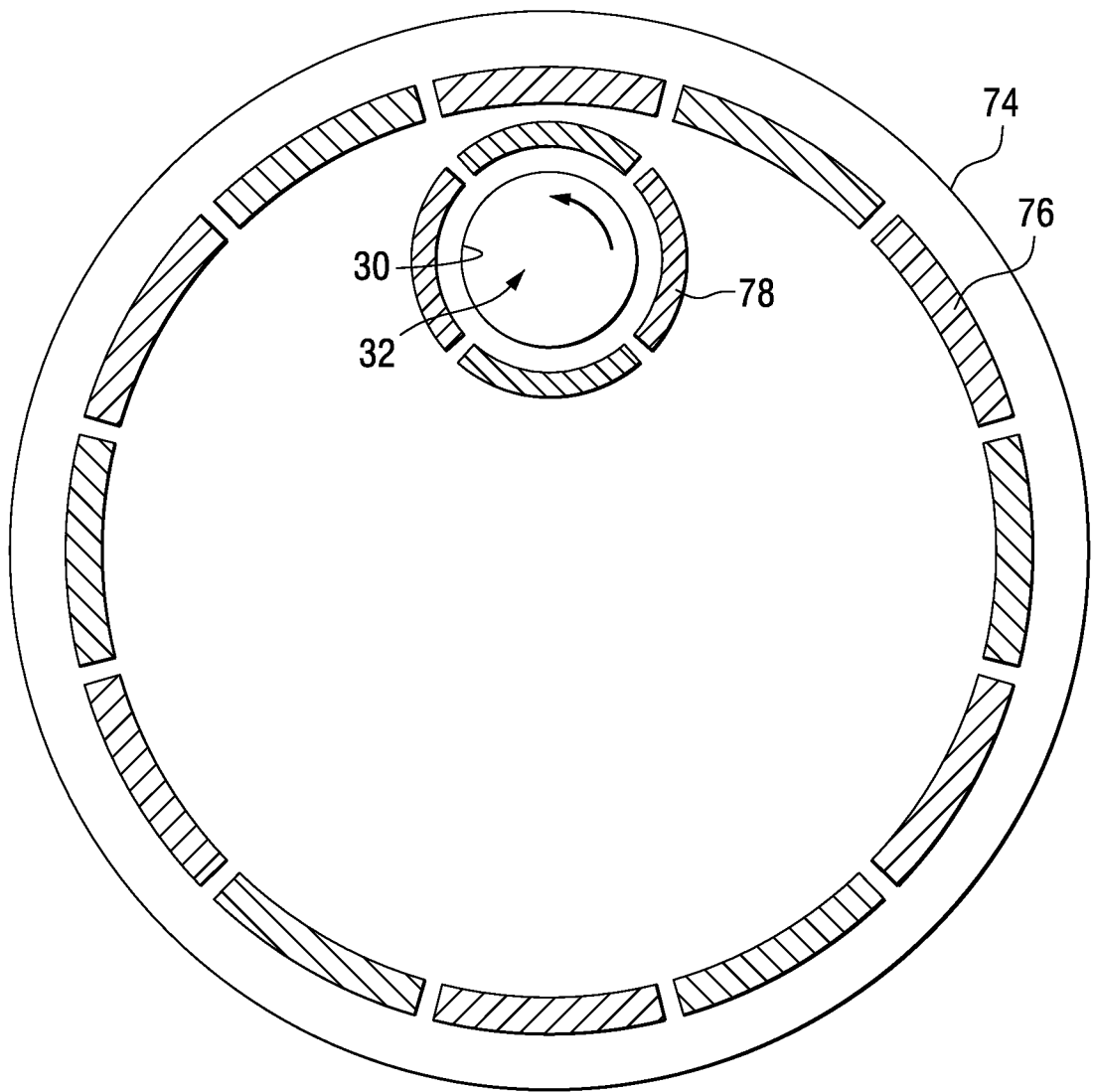

FIG. 5

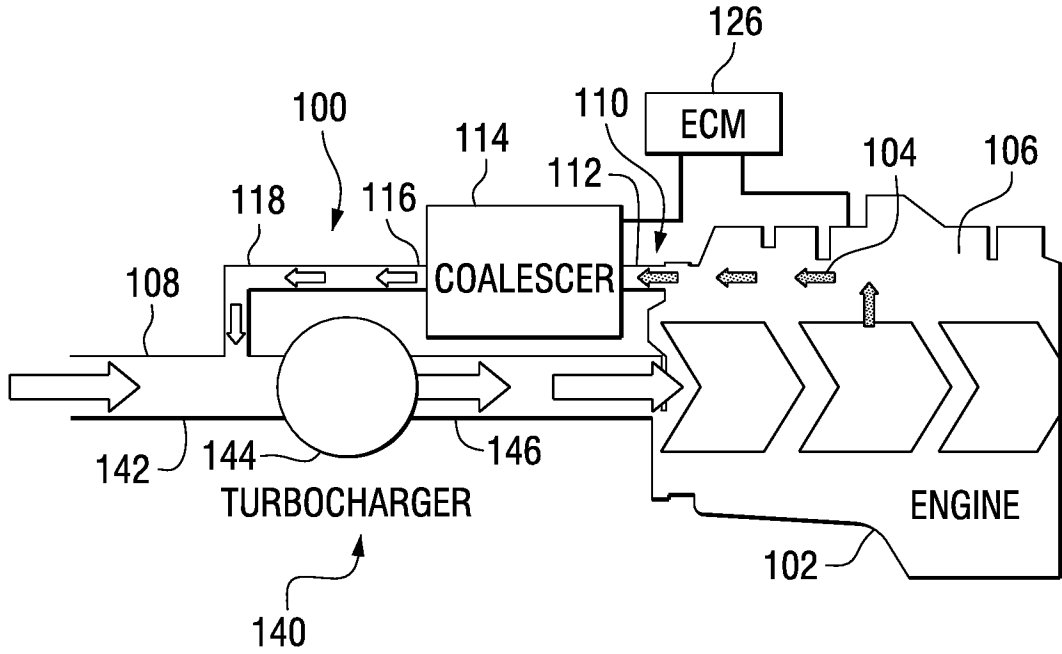

FIG. 6

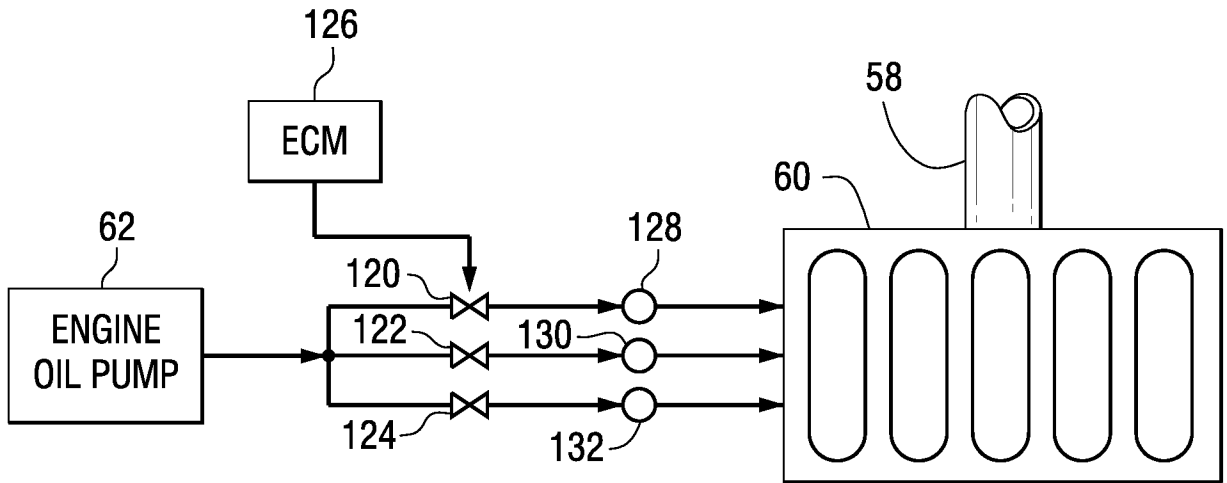

FIG. 7

7/16

FIG. 8

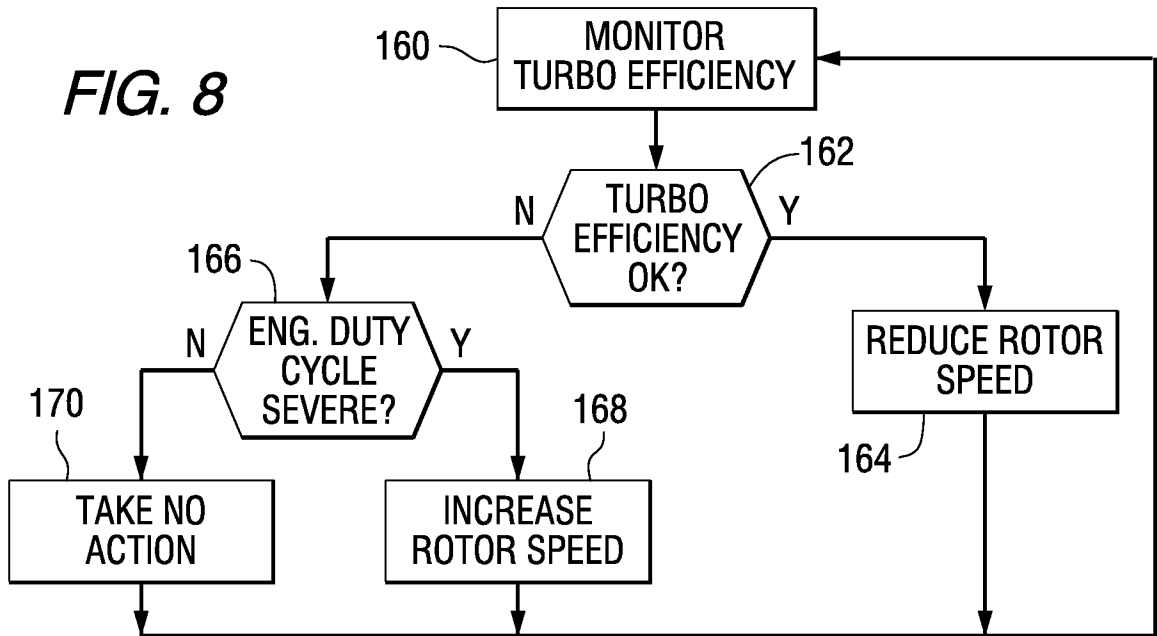
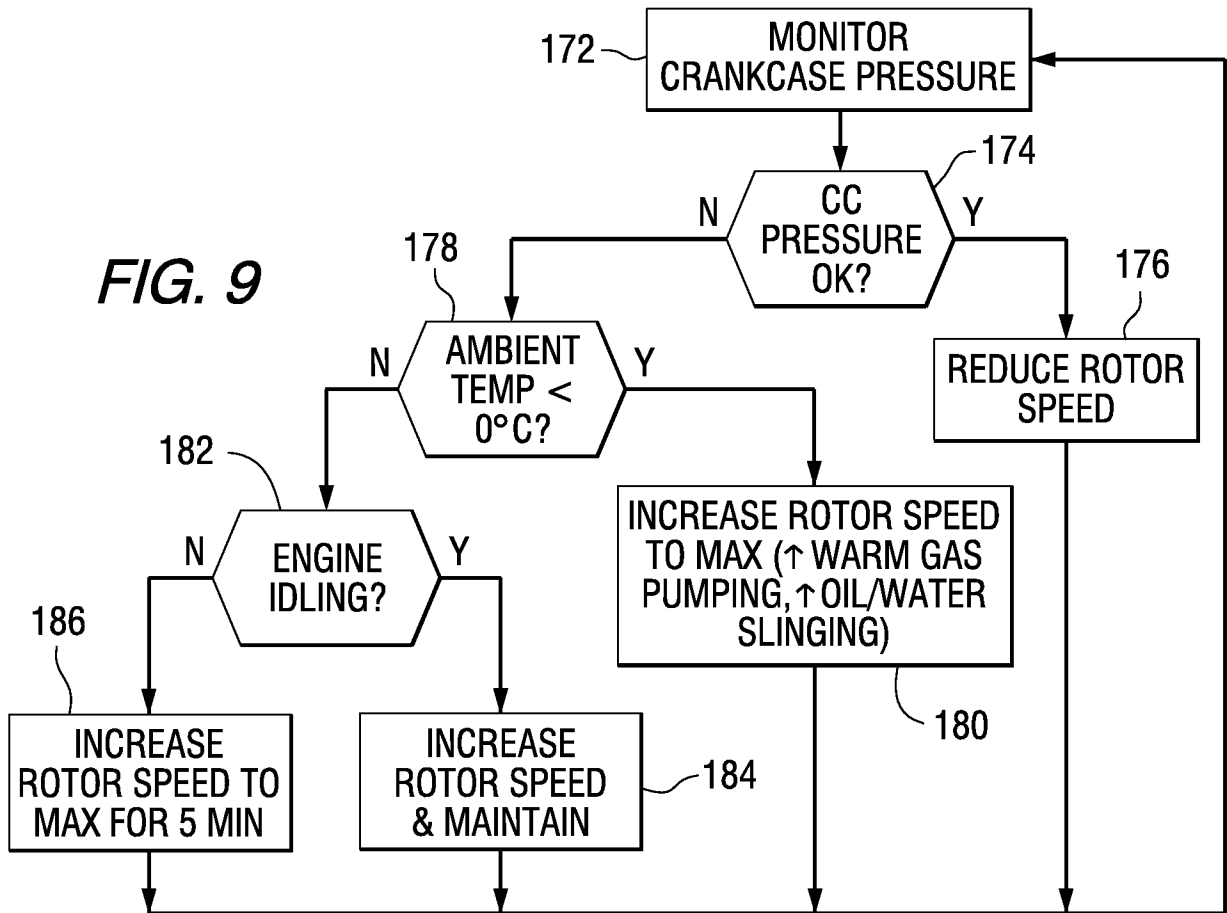

FIG. 9



8/16

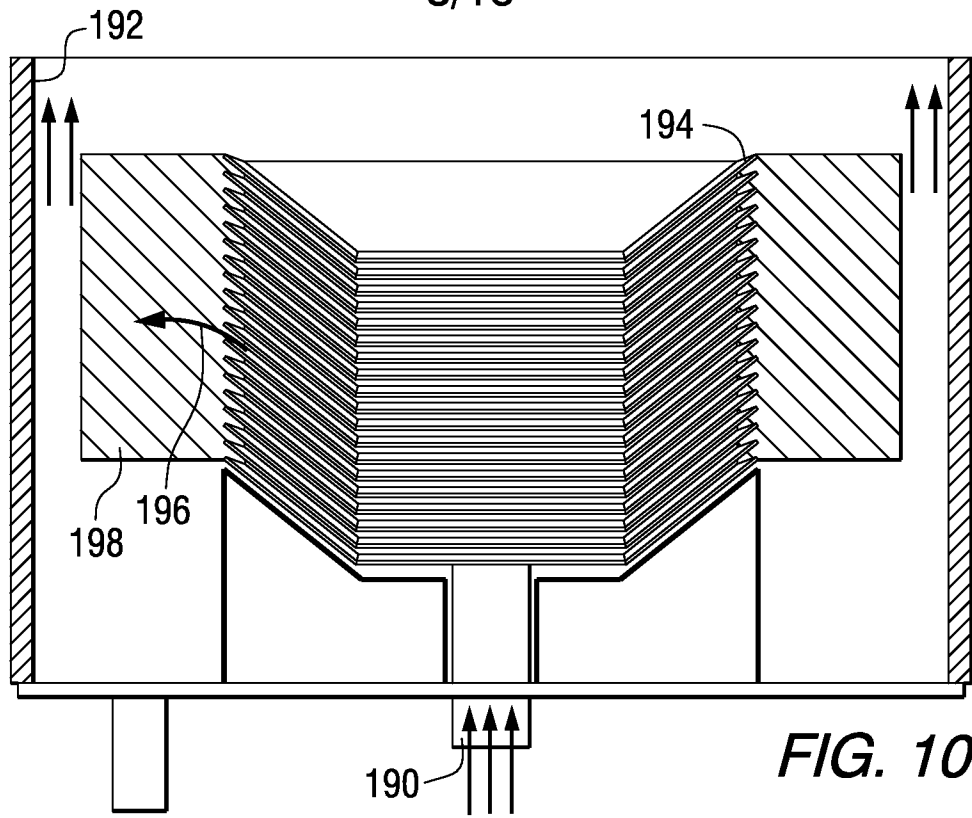

FIG. 10

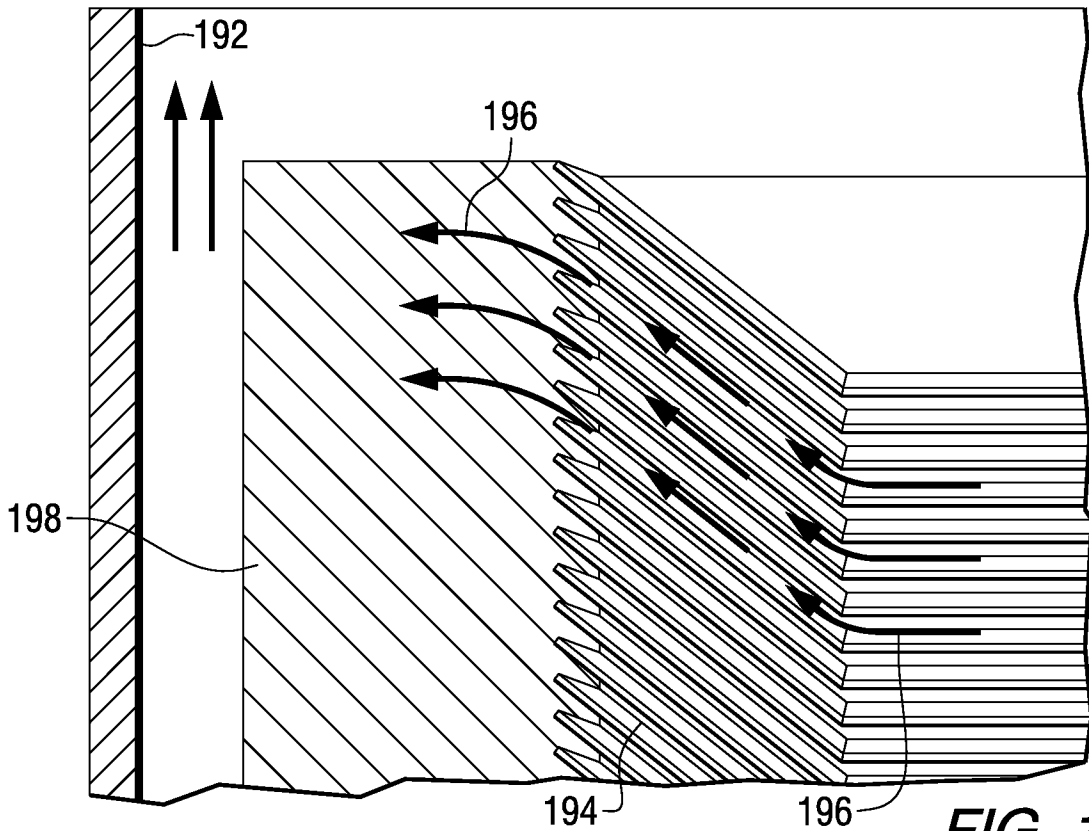

FIG. 11

9/16

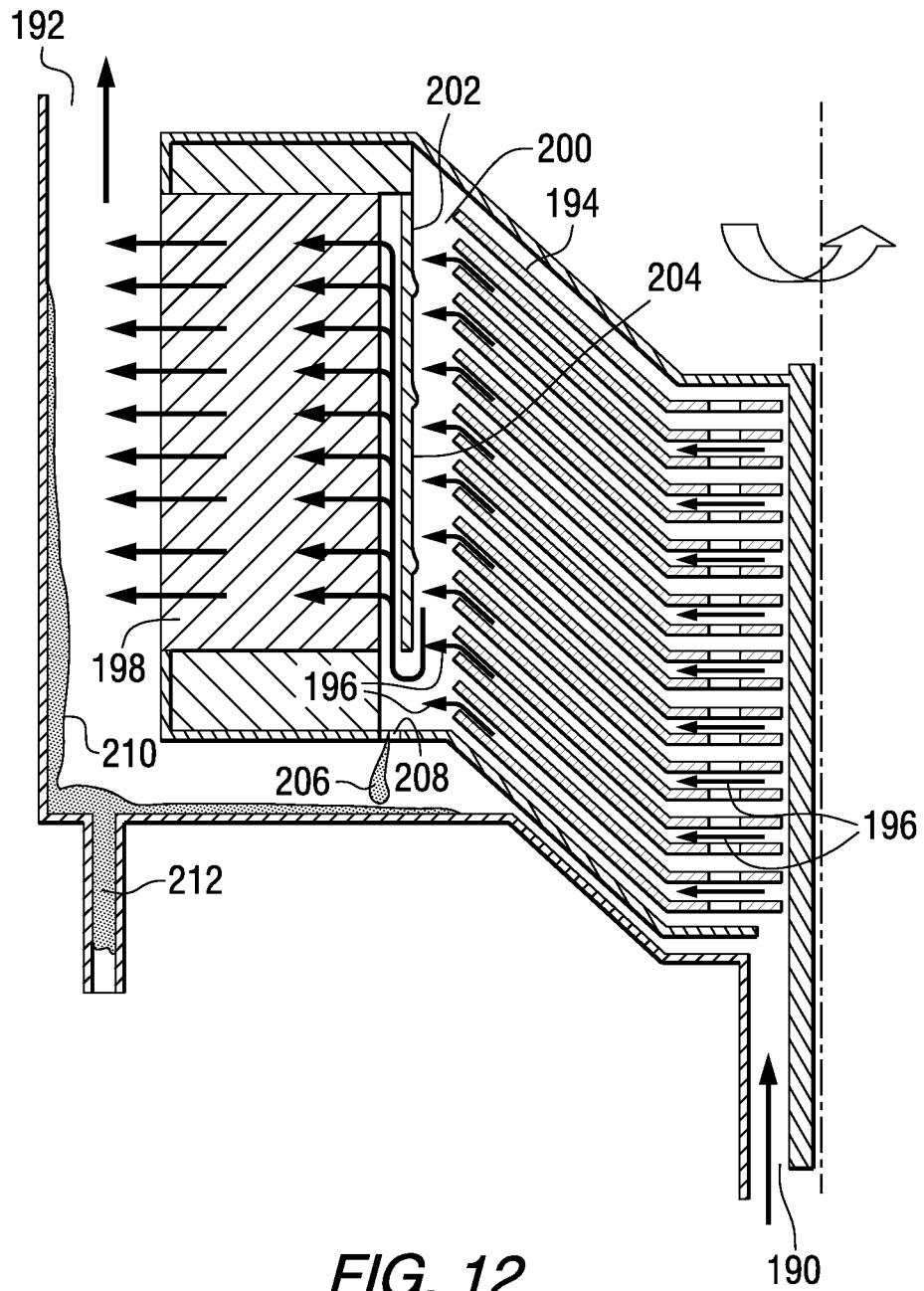

FIG. 12

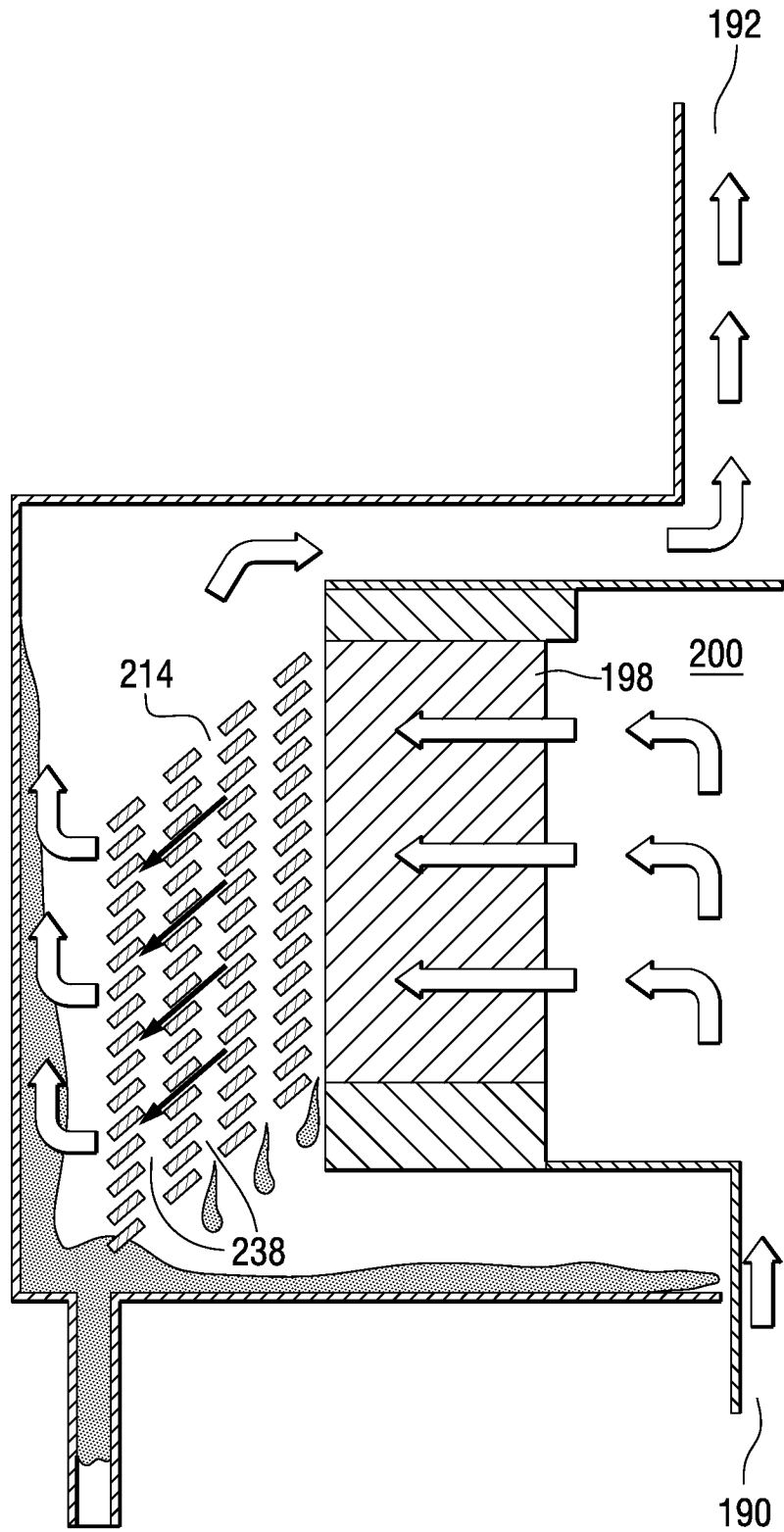
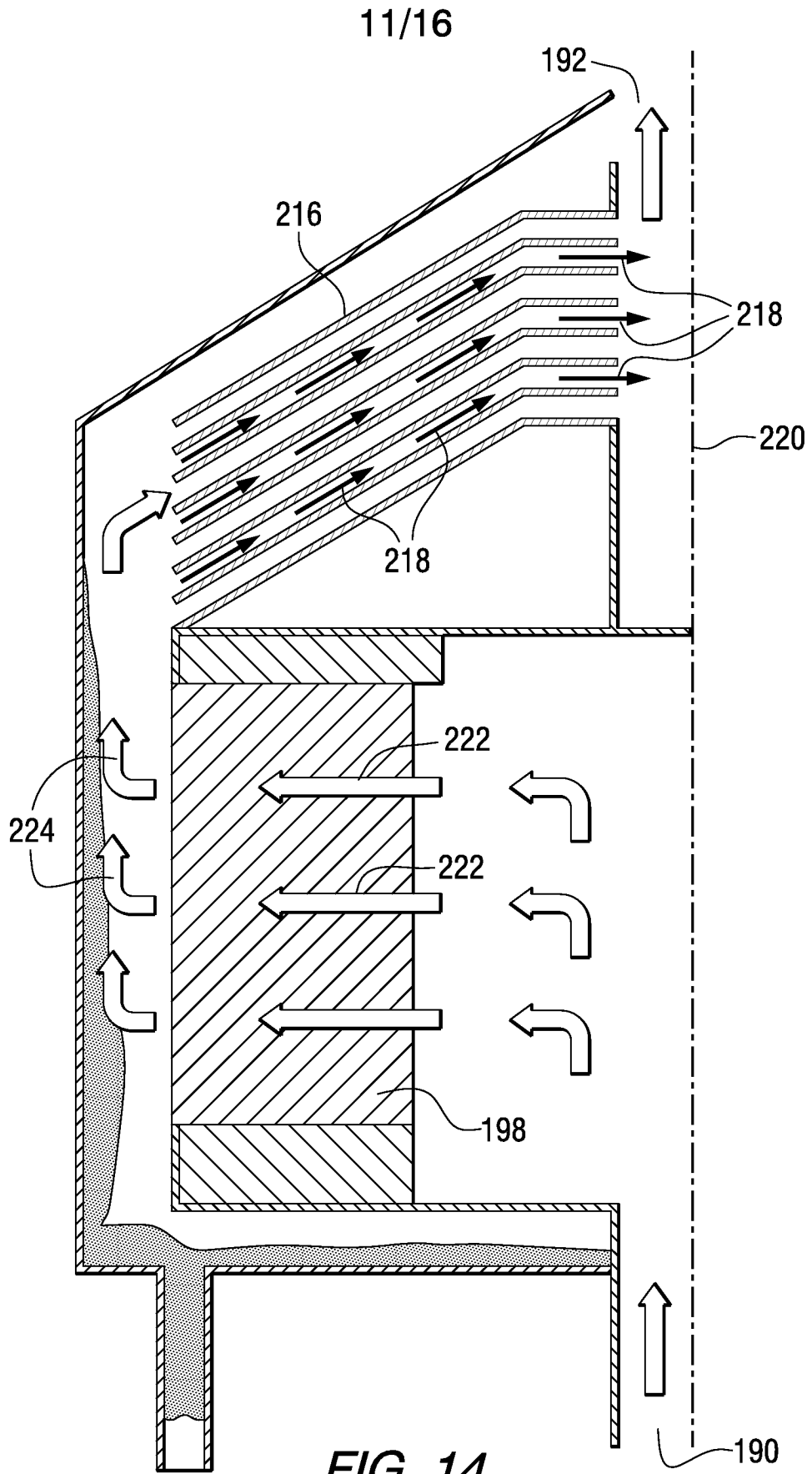

FIG. 13



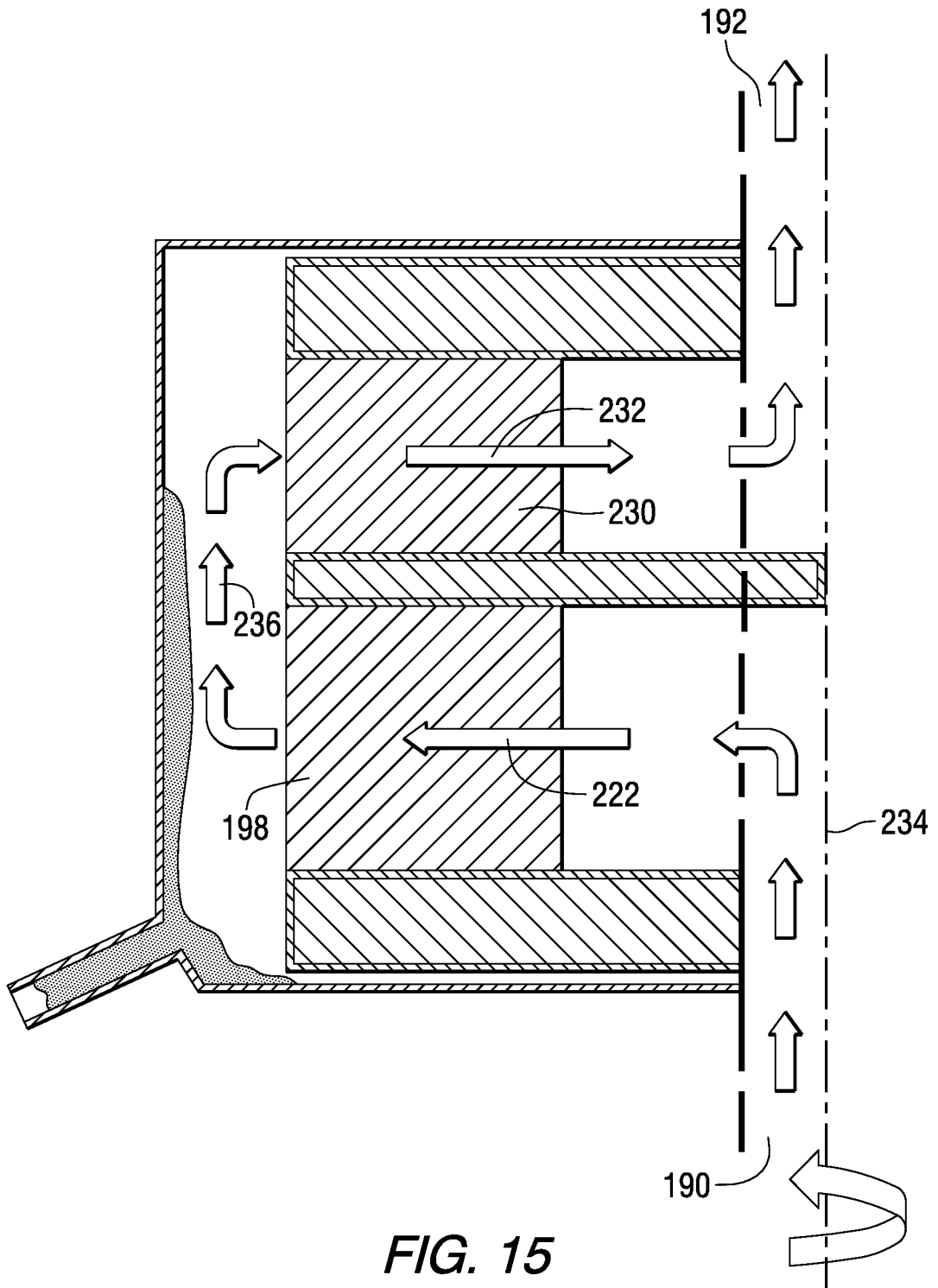

FIG. 15

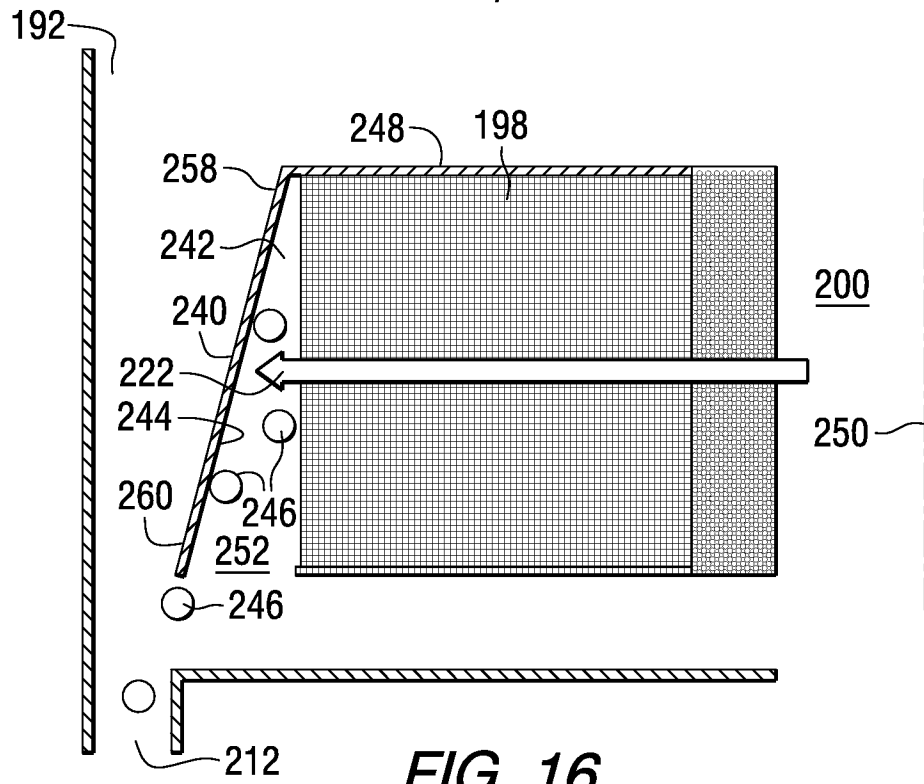

FIG. 16

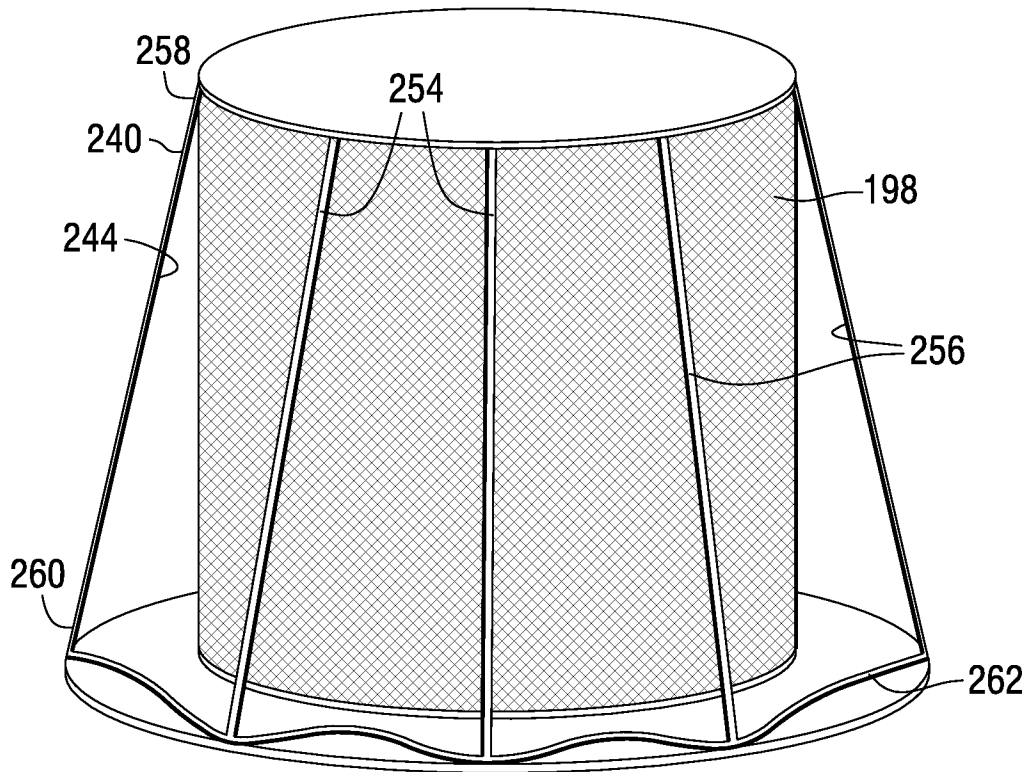

FIG. 17

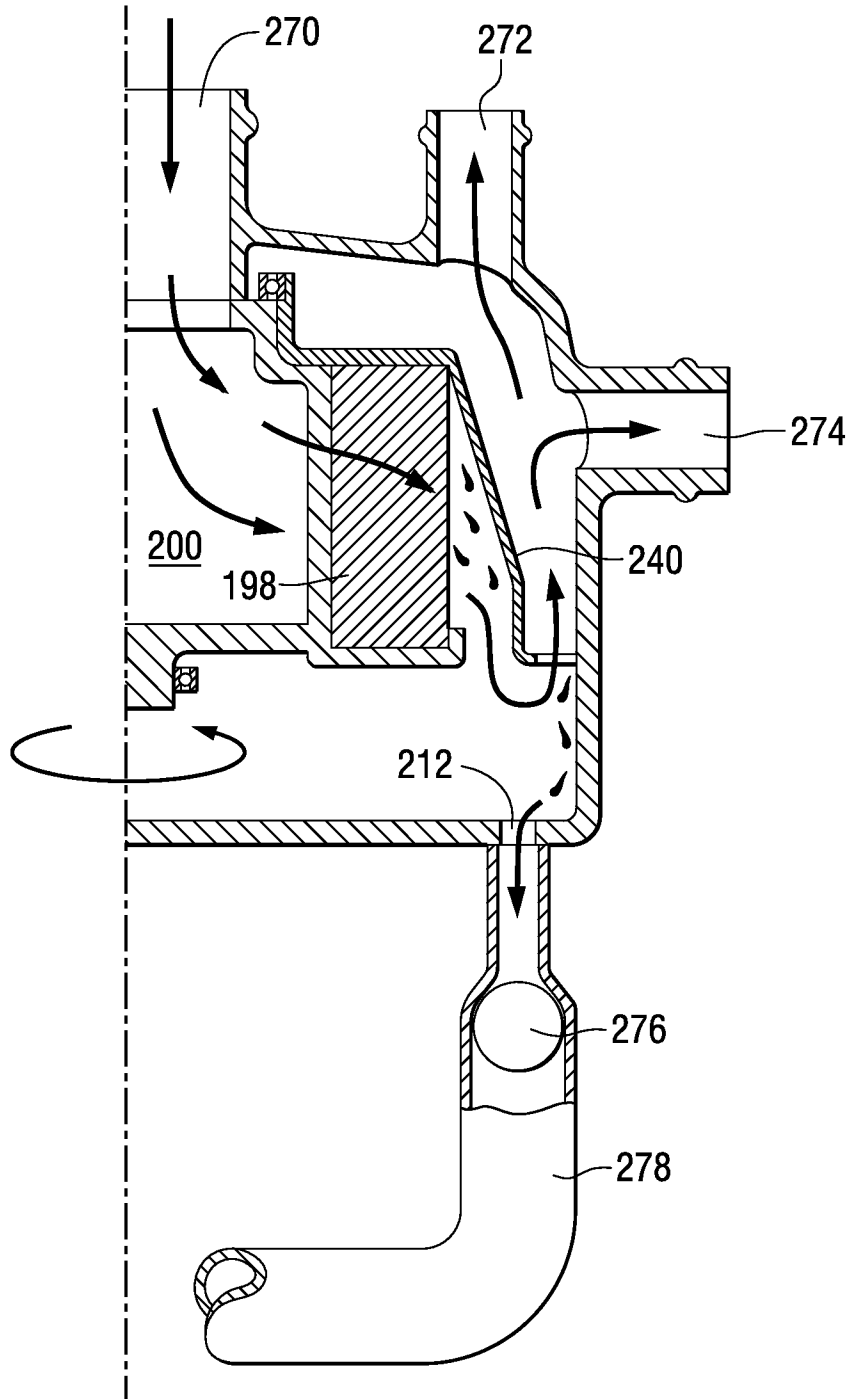
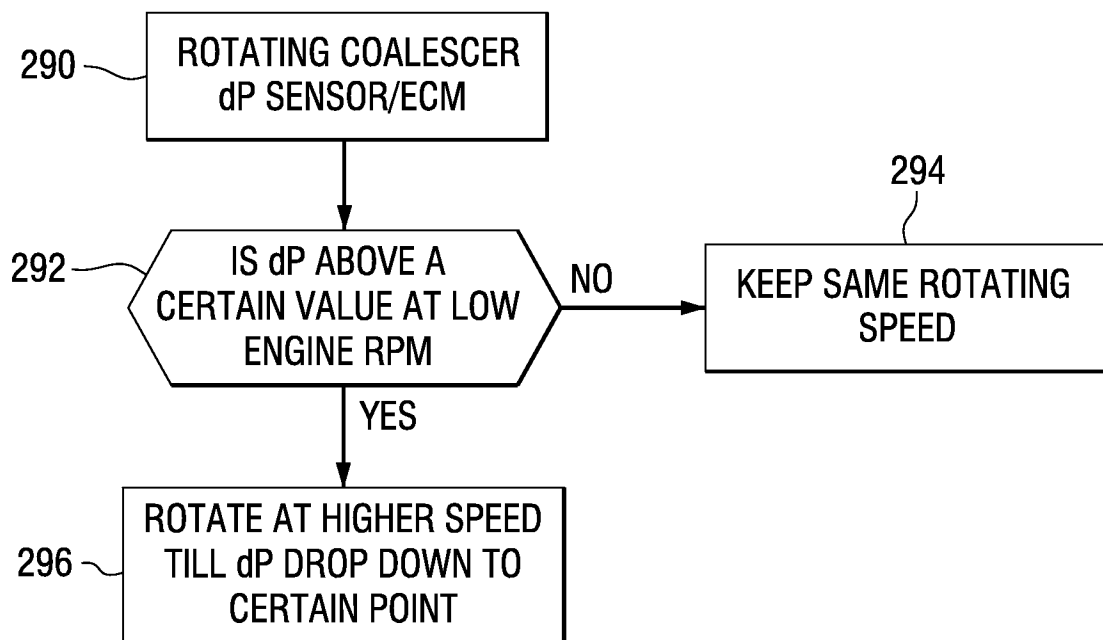

FIG. 18

15/16

**FIG. 19**

16/16

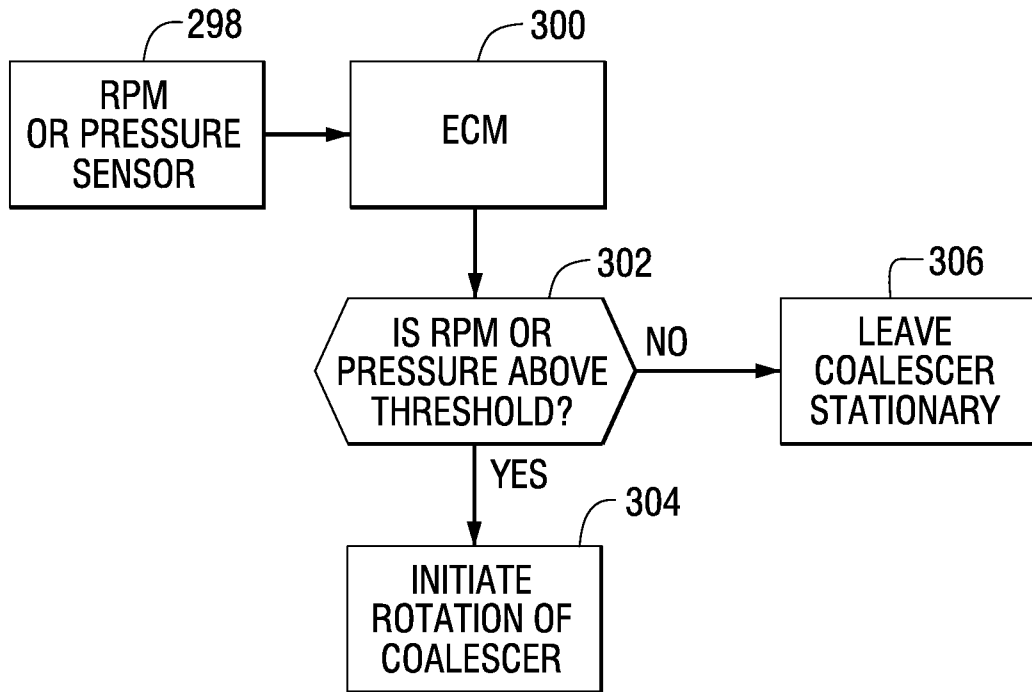

FIG. 20

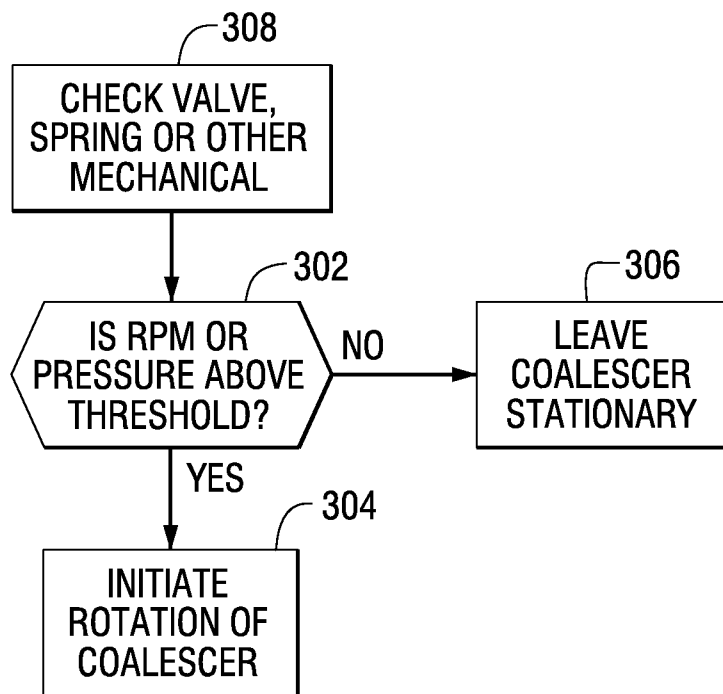

FIG. 21

INTERNATIONAL SEARCH REPORT

International application No.

PCT/US 11/21495

A. CLASSIFICATION OF SUBJECT MATTER
 IPC(8) - F02B 25/06 (2011.01)
 USPC - 123/573
 According to International Patent Classification (IPC) or to both national classification and IPC

B. FIELDS SEARCHED

Minimum documentation searched (classification system followed by classification symbols)
 IPC(8) - F02B 25/06 (2011.01)
 USPC - 123/573

Documentation searched other than minimum documentation to the extent that such documents are included in the fields searched
 USPC - 123/572, 574, 41.86 (text search - see terms below)

Electronic data base consulted during the international search (name of data base and, where practicable, search terms used)
 PubWEST(USPT,PGPB,EPAB,JPAB); Google Scholar; Google Patents
 Search Terms: crankcase, vent, coalescer, control, adjust, vary, speed, velocity, rotate, spin, separate, filter, engine, condition, parameter, electric, motor, hydraulic, drive, stop, intermittent, pressure, drop, turbocharger, efficiency, boost, etc.

C. DOCUMENTS CONSIDERED TO BE RELEVANT

Category*	Citation of document, with indication, where appropriate, of the relevant passages	Relevant to claim No.
X	US 6,152,120 A (Julazadeh) 28 November 2000 (28.11.2000), fig 1 and 2, col 1, ln 5-7 col 2, ln 6-51, col 3, ln 21-33	1-4, 6-9, 16, 21-27, 38 and 43
---		-----
Y		5, 10-15, 17-20, 28-37, 39-42 and 44-49
Y	US 5,911,213 A (Ahlborn et al.) 15 June 1999 (15.06.1999), col 2, ln 4-31	5, 10-12, 14, 17-20, 28-31, 33, 39-42 and 44-48
Y	US 5,090,873 A (Fain) 25 February 1992 (25.02.1992), fig 2; col 3, ln 48-63	11-15, 30-37 and 47-49

Further documents are listed in the continuation of Box C.

* Special categories of cited documents:

"A" document defining the general state of the art which is not considered to be of particular relevance	"T" later document published after the international filing date or priority date and not in conflict with the application but cited to understand the principle or theory underlying the invention
"E" earlier application or patent but published on or after the international filing date	"X" document of particular relevance; the claimed invention cannot be considered novel or cannot be considered to involve an inventive step when the document is taken alone
"L" document which may throw doubts on priority claim(s) or which is cited to establish the publication date of another citation or other special reason (as specified)	"Y" document of particular relevance; the claimed invention cannot be considered to involve an inventive step when the document is combined with one or more other such documents, such combination being obvious to a person skilled in the art
"O" document referring to an oral disclosure, use, exhibition or other means	"&" document member of the same patent family
"P" document published prior to the international filing date but later than the priority date claimed	

Date of the actual completion of the international search 10 March 2011 (10.03.2011)	Date of mailing of the international search report 29 MAR 2011
---	--

Name and mailing address of the ISA/US Mail Stop PCT, Attn: ISA/US, Commissioner for Patents P.O. Box 1450, Alexandria, Virginia 22313-1450 Facsimile No. 571-273-3201	Authorized officer: Lee W. Young PCT Helpdesk: 571-272-4300 PCT OSP: 571-272-7774
---	---