



US 20160187721A1

(19) **United States**

(12) **Patent Application Publication**

**GUO et al.**

(10) **Pub. No.: US 2016/0187721 A1**

(43) **Pub. Date: Jun. 30, 2016**

(54) **COLOR FILTER SUBSTRATE, LIQUID CRYSTAL DISPLAY PANEL AND DISPERSING METHOD OF MONOCOLOR QUANTUM DOTS**

(30) **Foreign Application Priority Data**

Jul. 24, 2013 (CN) ..... 201310314014.6

(71) Applicants: **BOE TECHNOLOGY GROUP CO., LTD.**, Beijing (CN); **BEIJING BOE OPTOELECTRONICS TECHNOLOGY CO., LTD.**, Beijing (CN)

**Publication Classification**

(51) **Int. Cl.**  
*G02F 1/1335* (2006.01)  
(52) **U.S. Cl.**  
CPC ..... *G02F 1/133516* (2013.01)

(72) Inventors: **RENWEI GUO**, Beijing (CN); **XUE DONG**, Beijing (CN); **ANG XIAO**, Beijing (CN)

(57) **ABSTRACT**

A color filter substrate is provided with a layered structure containing monocholor quantum dots in areas of sub-pixels of at least one color of the pixels, and the layered structure is formed by laminating flake graphene layers and monocholor quantum dot layers alternatively. The color filter substrate can efficiently convert background light into monochromatic light, can increase the color gamut of the liquid crystal display panel, enhances color saturation, and improves display quality of the display screen.

(21) Appl. No.: **15/062,747**

(22) Filed: **Mar. 7, 2016**

**Related U.S. Application Data**

(62) Division of application No. 14/360,517, filed on May 23, 2014, filed as application No. PCT/CN2013/084971 on Oct. 10, 2013.

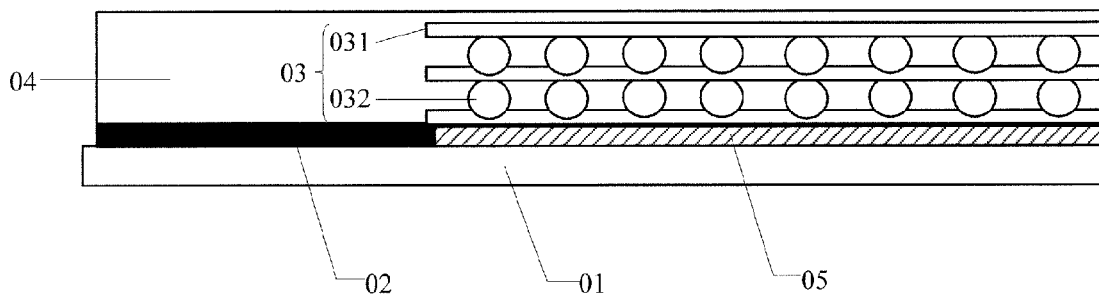

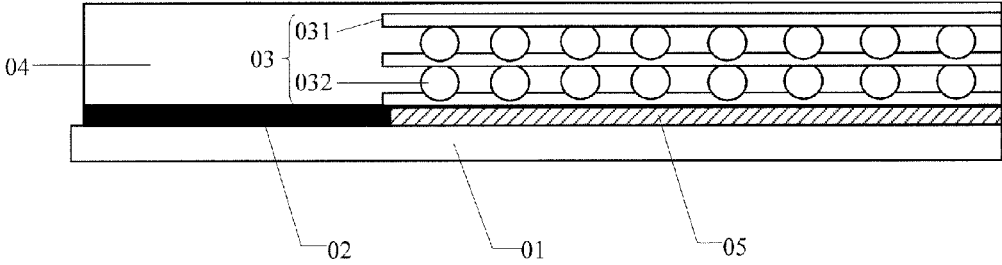

FIG. 1

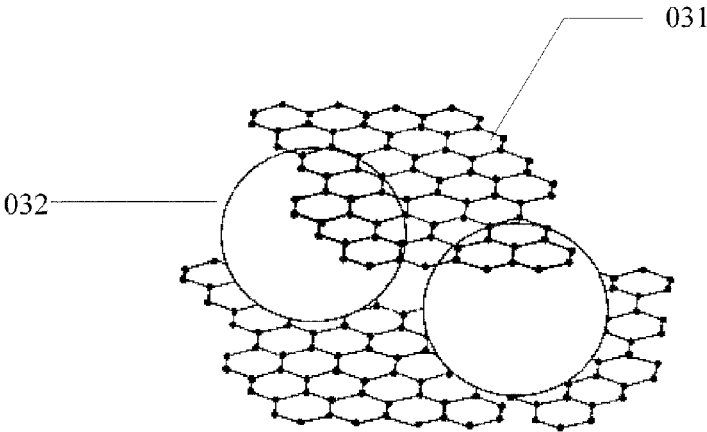

FIG. 2

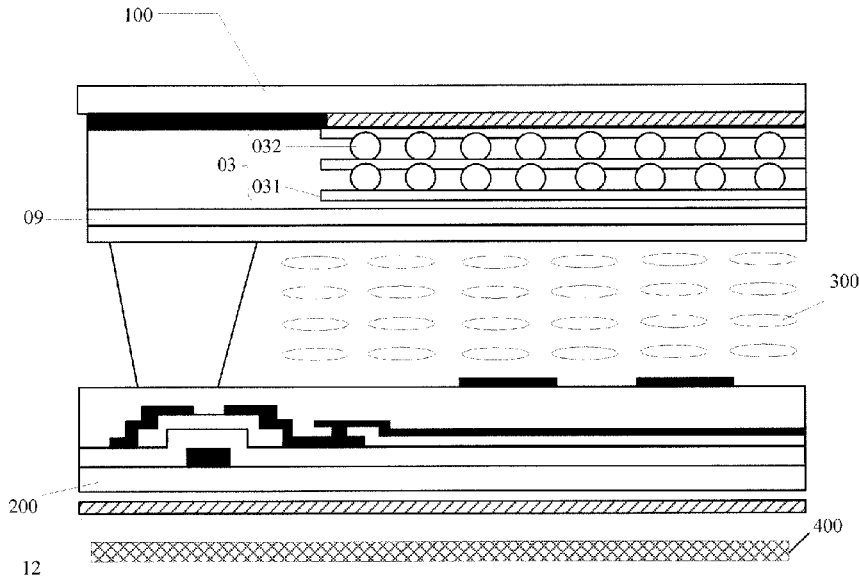

FIG. 3

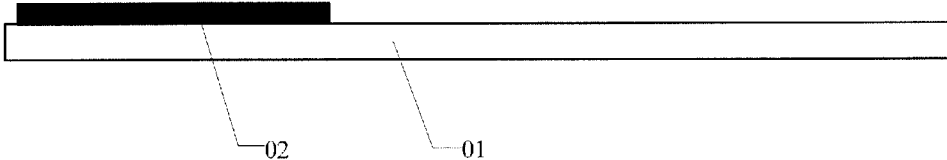

FIG. 4a

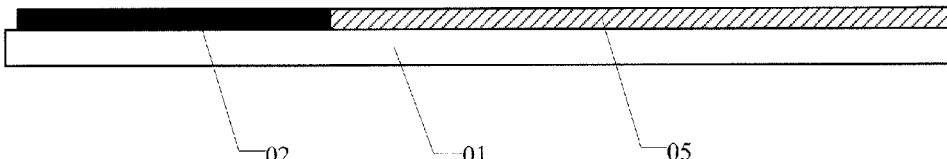

FIG. 4b

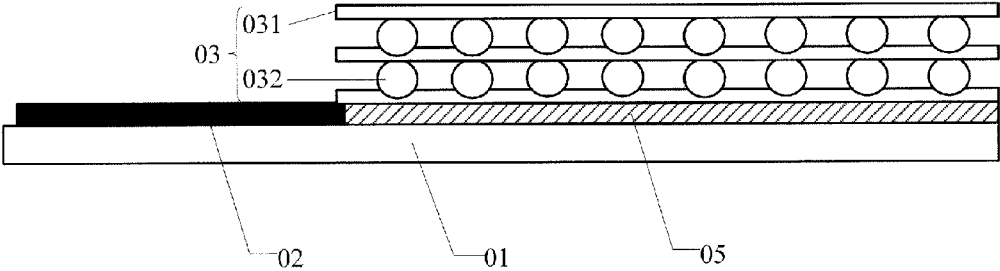

FIG. 4c

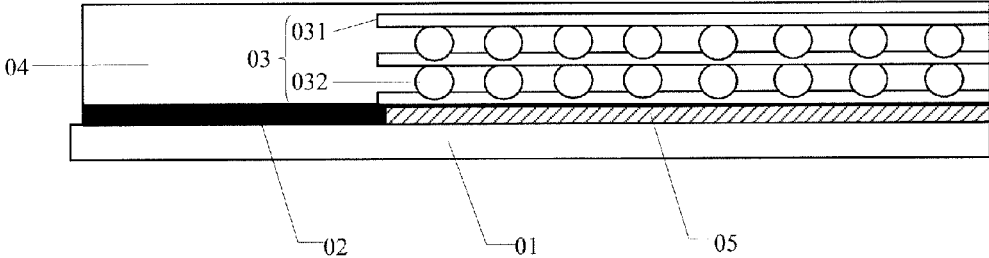

FIG. 4d

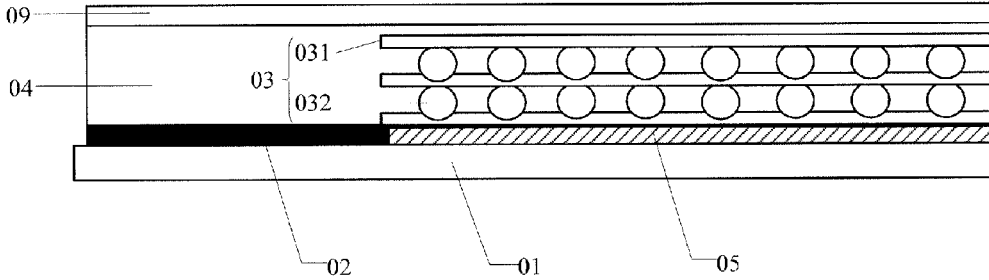

FIG. 4e

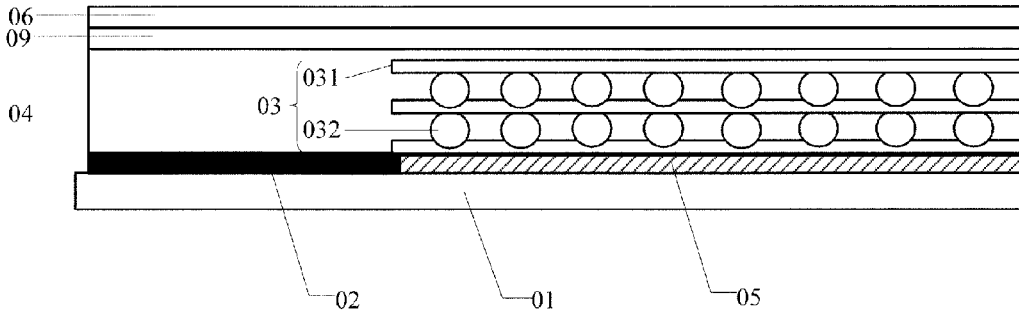

FIG. 4f

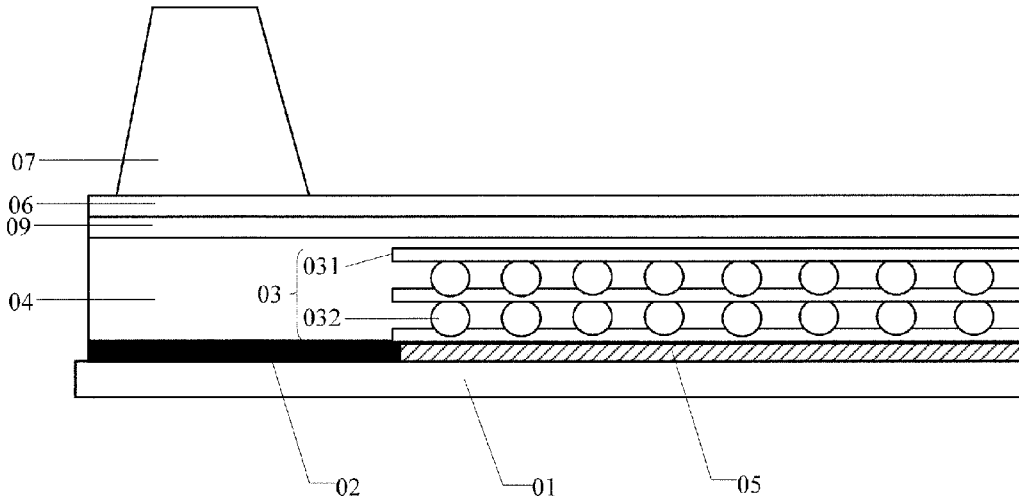

FIG. 4g

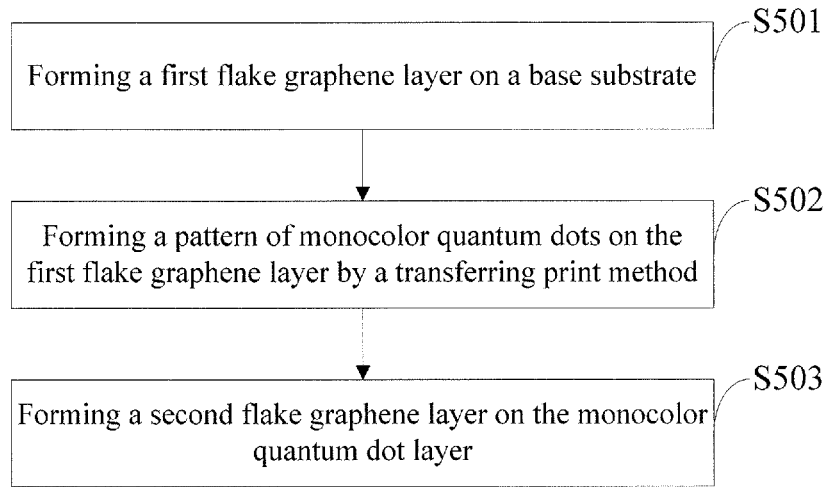

FIG. 5



FIG. 6a



FIG. 6b

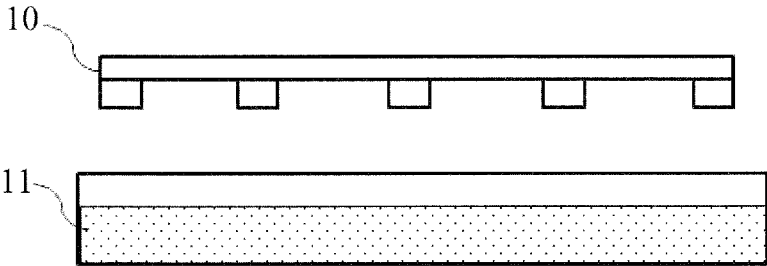

FIG. 6c

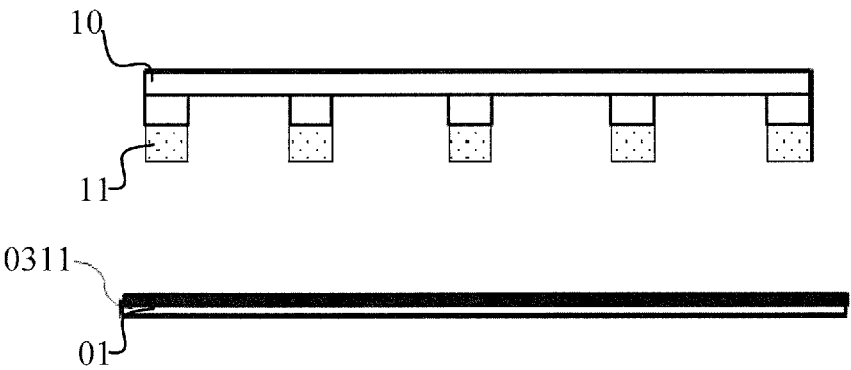

FIG. 6d

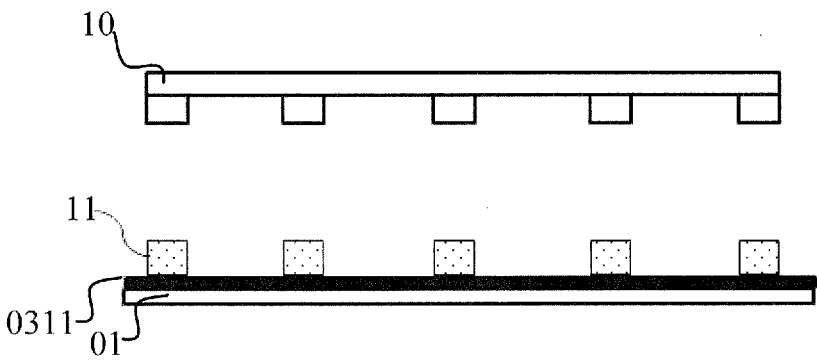

FIG. 6e

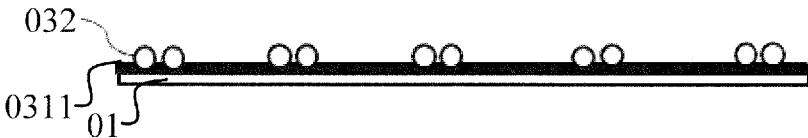

FIG. 6f

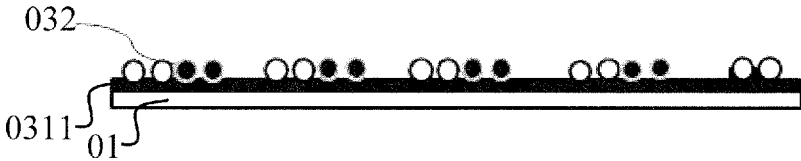

FIG. 6g



FIG. 6h



**COLOR FILTER SUBSTRATE, LIQUID  
CRYSTAL DISPLAY PANEL AND  
DISPERSING METHOD OF MONOCOLOR  
QUANTUM DOTS**

**TECHNICAL FIELD**

[0001] Embodiments of the present invention relate to a color filter substrate, a liquid crystal display panel, a display device and a dispersing method of monicolor quantum dots.

**BACKGROUND**

[0002] Quantum dots, also known as nanometer crystals, belong to one kind of nanometer particles formed of II-VI group or III-V group elements. Particle diameters of quantum dots are generally from 1 nm to 20 nm. Since electrons and holes are quantumly localized, and continuous energy band structure becomes a structure having discrete energy levels, quantum dots emit fluorescent light after being excited.

[0003] Emission spectrum of quantum dots can be controlled by changing sizes of quantum dots. By changing the sizes and elementary composition of quantum dots, it is possible to make their emission spectrum to cover the entire visible light region. Taking CdTe quantum dots as an example, when their particle diameters increase from 2.5 nm to 4.0 nm, their emission wavelength may be red-shifted from 510 nm to 660 nm.

[0004] At present, by means of luminescence characteristics of quantum dots, it is possible to apply quantum dots as molecule probes to fluorescence labeling, or to display devices. For example, while using monicolor quantum dots as a light emitting source of a backlight module of a liquid crystal display panel, monicolor quantum dots emit monochromatic light after being excited by blue light LEDs for example, and the excited monochromatic light is mixed with the blue light to form white background light. This kind of backlight source has a large color gamut and can improve picture quality.

[0005] Due to the poor dispersibility of nanometer order quantum dots in organic solvent, quantum dot aggregation occurs, when they are used to manufacture patterns, results in the phenomenon of quenching, which severely reduces quantum yield. Therefore, there has been no design presently in which quantum dots are applied to liquid crystal display panels.

**SUMMARY**

[0006] Embodiments of the present invention provide a color filter substrate, a liquid crystal display panel, a display device and a dispersing method of monicolor quantum dots to increase the color gamut of the display screen and hence improve picture quality.

[0007] One embodiment of the present invention provides a color filter substrate comprising: a base substrate; a plurality of pixels provided on the base substrate, each comprised of a plurality of sub-pixels of different colors; and a layered structure containing monicolor quantum dots disposed in areas corresponding to sub-pixels of at least one color of pixels. The layered structure comprises an alternate lamination of flake graphene layers and monicolor quantum dot layers. A bottom layer and a top layer of the layered structure are both flake graphene layers; and the monicolor quantum dots emit monochromatic light corresponding to a color of the sub-pixels after being excited.

[0008] For example, furthermore, in order to increase service life of monicolor quantum dots, the above-mentioned color filter substrate may further comprise: a protection layer covering the layered structure.

[0009] Another embodiment of the present invention further provides a liquid crystal display panel comprising: a color filter substrate, an array substrate and a liquid crystal layer between the color filter substrate and the array substrate, and the color filter substrate is the above-mentioned color filter substrate.

[0010] For example, furthermore, in order for the liquid crystal display panel to be able to display normally, the above-mentioned liquid crystal display panel may further comprise: a lower polarization sheet on one side of the array substrate opposite to the liquid crystal layer and an upper polarization sheet on one side of the layered structure facing the liquid crystal layer in the color filter substrate.

[0011] For example, furthermore, in order for the liquid crystal display panel to be able to display normally, the liquid crystal display panel can further comprise: a backlight module emitting blue light or ultraviolet light on one side of the array substrate opposite to the liquid crystal layer.

[0012] Yet another embodiment of the present invention further provides a display device comprising any of the above-mentioned liquid crystal display panels provided in embodiments of the present invention.

[0013] Yet another embodiment of the present invention further provides a dispersing method of monicolor quantum dots comprising: forming a first flake graphene layer on a base substrate; forming a pattern of monicolor quantum dots on the first flake graphene layer by a transfer print method; and forming a second flake graphene layer on the monicolor quantum dot layer.

[0014] For example, furthermore, in the above-mentioned method, the first flake graphene layer or second flake graphene layer is formed according to the following steps: mixing graphene powder, ethyl cellulose and organic solvent to obtain mixture solution; coating the mixture solution onto the base substrate or the monicolor quantum dot layer; and removing the organic solvent and ethyl cellulose in the mixture solution by drying and heating to obtain the first flake graphene layer formed on the base substrate or the second flake graphene layer formed on the monicolor quantum dot layer.

[0015] For example, furthermore, in the above-mentioned method, the graphene powder accounts for 1%-10% mass percent with respect to the ethyl cellulose; a sum of the graphene powder and the ethyl cellulose accounts for 20%-50% mass percent with respect to the organic solvent.

[0016] For example, furthermore, the organic solvent in the above-mentioned method may be ethanol.

[0017] For example, furthermore, in the above-mentioned method, forming of a pattern of monicolor quantum dots on the first flake graphene layer comprises: dipping a transfer print plate in the monicolor quantum dot solution; performing transfer printing with the transfer print plate carrying monicolor quantum dot solution on the first flake graphene layer of the base substrate; and drying the monicolor quantum dot solution on the first flake graphene layer to obtain the pattern of monicolor quantum dot layer formed on the first flake graphene layer.

## BRIEF DESCRIPTION OF THE DRAWINGS

**[0018]** In order to clearly illustrate the technical solution of the embodiments of the invention, the drawings of the embodiments will be briefly described in the following; it is obvious that the described drawings are only related to some embodiments of the invention and thus are not limitative of the invention.

**[0019]** FIG. 1 is a structure diagram of a color filter substrate provided in an embodiment of the present invention;

**[0020]** FIG. 2 is a structure diagram of a layered structure of the color filter substrate provided in an embodiment of the present invention;

**[0021]** FIG. 3 is a structure diagram of a liquid crystal display panel provided in an embodiment of the present invention;

**[0022]** FIGS. 4a-4g are structure diagrams of steps of manufacturing color filter substrate in the liquid crystal display panel provided in an embodiment of the present invention;

**[0023]** FIG. 5 is a flowchart of a dispersing method of monocholor quantum dots provided in an embodiment of the present invention; and

**[0024]** FIGS. 6a-6h are sketch maps of steps of the dispersing method of monocholor quantum dots provided in an embodiment of the present invention.

## DETAILED DESCRIPTION

**[0025]** In order to make objects, technical details and advantages of the embodiments of the invention apparent, the technical solutions of the embodiments will be described in a clearly and fully understandable way in connection with the drawings related to the embodiments of the invention. Apparently, the described embodiments are just a part but not all of the embodiments of the invention. Based on the described embodiments herein, those skilled in the art can obtain other embodiment(s), without any inventive work, which should be within the scope of the invention.

**[0026]** Specific examples of the color filter substrate, the liquid crystal display panel and the display device and the dispersing method of monocholor quantum dots provided in embodiments of the present invention will be described in detail below.

**[0027]** Shapes and sizes of film layers in the accompanying drawings do not reflect the actual scales of the array substrate or the color filter substrate, with the only purpose for illustrating contents of the present invention.

**[0028]** An embodiment of the present invention provides a color filter substrate as illustrated in FIG. 1, and the color filter substrate includes a base substrate **01** and a black matrix **02** disposed on the base substrate **01**. The pattern of the black matrix **02** defines a plurality of sub-pixel areas on the base substrate **01** (only one sub-pixel area is illustrated in FIG. 1) and every adjacent plurality of (two or more of) sub-pixel areas constitute one pixel area. The base substrate is for example a glass substrate or a plastic substrate. The black matrix **02** is fabricated from for example a black resin material or a metal oxide. For example, each pixel area includes red, green and blue sub-pixel areas.

**[0029]** The color filter substrate further includes: a layered structure **03** containing monocholor quantum dots provided in sub-pixel areas of at least one color of pixel areas. The layered structure **03** is formed by laminating flake graphene layers **031** and monocholor quantum dot layers **032** alternatively. The

bottom layer and top layer of the layered structure **03** are both flake graphene layers **031**. Monocholor quantum dots in the monocholor quantum dot layer **032**, after being excited by light, emit monochromatic light of the color corresponding to the sub-pixel such as red or green. For example, the layered structure **03** contains three flake graphene layers **031** and two monocholor quantum dot layers **032** of which each is sandwiched between two flake graphene layers **031** respectively.

**[0030]** In the above-mentioned color filter substrate provided in an embodiment of the present invention, a layered structure containing monocholor quantum dots is used instead of conventional color resin as a color filter to convert the backlight into monochromatic light. Since the emission spectrum of monocholor quantum dots is narrow and their luminescence efficiency is high, it is possible to convert backlight efficiently into monochromatic light, which can increase the color gamut of the liquid crystal display panel, enhance color saturation and improve the display quality of the display screen.

**[0031]** Further, the process of laminating flake graphene layers **031** and monocholor quantum dot layers **032** alternately to form the layered structure **03** can disperse monocholor quantum dots uniformly between adjacent flake graphene layers **031**, as illustrated in FIG. 2. This can prevent monocholor quantum dots from aggregating, enhance quantum yield of the quantum dots to improve light efficiency for quantum excitation. In addition, as illustrated in FIG. 2, a flake graphene layer **031** is arranged in a planar single layer of carbon atoms and has the characteristics of a two dimensional network structure. Therefore, the flake graphene layers **031** are transparent themselves, and will not influence normal display of liquid crystal display panel.

**[0032]** It is to be noted that the layered structure containing monocholor quantum dots described in embodiments of the present invention involves the case that quantum dots of sub-pixels of the same color are the same, and quantum dots of sub-pixels of different colors are different. Here, difference may be in size or material of the quantum dots, so long as it is ensured that quantum dots corresponding to sub-pixels of various colors, after being excited, emit only monochromatic light of the colors corresponding to the sub-pixels. That is, quantum dots of various sub-pixel areas of the layered structure containing monocholor quantum dots can only emit monochromatic light after being excited, but the areas corresponding to sub-pixel areas of different colors emit different monochromatic light.

**[0033]** In the present embodiment, traditional quantum dot materials may be adopted which may be at least one of zinc sulfide, zinc oxide, gallium nitride, zinc selenide, cadmium sulfide, gallium selenide, cadmium selenide, zinc telluride, cadmium telluride, gallium arsenide, indium phosphide, or lead telluride. Of course, materials for the quantum dots include, but not limited to the above listed, other materials with the properties same as or similar to the above-mentioned substances are also applicable. Taking zinc sulfide (ZnS) quantum dots as an example, quantum dots emitting red light have sizes mainly ranging 9~10 nm, quantum dots emitting yellow light have sizes of 8 nm or so, and quantum dots emitting green light have sizes of 7 nm or so.

**[0034]** Furthermore, in order to avoid the contact between monocholor quantum dot layers **032** in the layered structure **03** and the air, in the above-mentioned color filter substrate provided in embodiments of the present invention, a protection layer **04** covering the layered structure **03** may be further

provided as illustrated in FIG. 1. The protection layer **04** is typically formed of an organic resin material, which can avoid contact of monochrome quantum dots with oxygen and water, increasing service life of monochrome quantum dots.

**[0035]** In the process of forming film layers of the color filter substrate, it is typically to form the pattern of black matrix **02** first on the base substrate **01**, and the black matrix **02** defines a plurality of sub-pixel areas on the base substrate **01** to prevent light cross-talk from influencing display effect. In one example, in order to facilitate continuity of subsequently formed flake graphene in the same horizontal plane, as illustrated in FIG. 1, it is possible to provide a planarization layer **05** filling the hollow-out areas, namely sub-pixel areas in the pattern of the black matrix **02**, and the planarization layer can planarize the surface of the base substrate **01**. For example, the planarization layer **05** may be made of a resin material.

**[0036]** Another embodiment of the present invention further provides a liquid crystal display panel as illustrated in FIG. 3, and the liquid crystal display panel includes: a color filter substrate **100**, an array substrate **200** and a liquid crystal layer **300** interposed between the color filter substrate **100** and the array substrate **200**. The color filter substrate **100** is any of the above-mentioned color filter substrates provided in the embodiments of the present invention, while the array substrate **200** includes for example an array of sub-pixel areas corresponding to the array of sub-pixel areas of the color filter substrate **100**. The pixel electrode of each sub-pixel area of the array substrate **200** is configured to form an electric field for controlling rotation degree of liquid crystal material, and hence carrying out display operation. The array substrate **100** and the color filter substrate **200** are disposed opposite to each other and assembled together with sealant to form a liquid crystal cell in which liquid crystal material is filled. These two substrates may be separated by spacers (column spacers or sphere spacers) to keep a certain gap therebetween. Since this liquid crystal display panel solves the problem with a principle similar to the aforementioned color filter substrates, examples of the liquid crystal display panel can be referred to the implementations of the color filter substrate, and repetition will not be described any longer here.

**[0037]** The above-mentioned liquid crystal display panel provided in embodiments of the present invention may be of various modes, such as the advanced super dimension switch (ADSDS) liquid crystal display panel that can realize wide view angle, and traditional twisted nematic (TN) liquid crystal display panel, which are not limited here.

**[0038]** For example, an ADSDS type liquid crystal display panel is described as an example for the above-mentioned liquid crystal display panel provided in the embodiments of the present invention. For example, for a TN type liquid crystal display panel, the color filter substrate may further include a common electrode layer on one side facing the liquid crystal layer for cooperating with pixel electrodes on the array substrate to form an electric field for driving liquid crystal materials.

**[0039]** For example, as illustrated in FIG. 3, the above-mentioned liquid crystal display panel may further comprise: a lower polarization sheet **12** on one side of the array substrate **200** opposite to the liquid crystal layer **300**, and an upper polarization sheet **09** on one side of the layered structure **03** facing the liquid crystal layer **300** in the color filter substrate **100**. The lower polarization sheet **12** on one side of the array substrate **200** opposite to the liquid crystal layer **300** may be

manufactured by the process and material for manufacturing polarization sheets attached in a traditional liquid crystal display panel, which will not be described any longer here.

**[0040]** For example, the upper polarization sheet **09** may be manufactured with azo serial photosensitive resin(s), and then after directional ultraviolet illumination, the film with polarization effect is obtained by iodine solvent washing.

**[0041]** Furthermore, the upper polarization sheet **09** contained in the above-mentioned liquid crystal display panel provided in an embodiment of the present invention may also be provided for example by the process of attaching it on one side of the color filter substrate **100** opposite to the liquid crystal layer **300**, and for example the same process and material for attaching the lower polarization sheet on one side of the array substrate **200** opposite to the liquid crystal layer **300** can be used, which is not limited here.

**[0042]** In the liquid crystal display panel provided in embodiments of the present invention, there may also be provided with a backlight module **400** on one side of the array substrate **200** opposite to the liquid crystal layer **300**. For example, the backlight module **400** emits blue light with a central wavelength preferably at 450 nm such that monochrome quantum dots in the layered structure of the color filter substrate **100** emit corresponding monochromatic light after being excited. Of course, it is also possible to select near ultraviolet light as the backlight for exciting quantum dots depending on the selected excitation wavelength of quantum dots, which is not limited here.

**[0043]** When the above-mentioned liquid crystal screen provided in embodiments of the present invention is working, the blue light emitted by the backlight module **400** passes through the lower polarization sheet **12** and is modulated by the liquid crystal layer **300**, then is incident onto the polarization sheet **09** that serves as a polarization layer. Then it is incident onto the layered structure **03** containing monochrome quantum dots. Monochrome quantum dots in various layered structures **03** generate corresponding monochromatic light while being excited by backlight, realizing liquid crystal color display panel.

**[0044]** For example, the manufacturing process for the color filter substrate **100** provided with the upper polarization sheet **09** will be explained below, which includes the following steps:

**[0045]** (1) Forming a pattern of the black matrix **02** (BM) on the base substrate **01** by for example a printing or photography method as illustrated in FIG. **4a**;

**[0046]** (2) Forming a planarization layer **05** on the hollow out areas, i.e., sub-pixel areas in the pattern of the black matrix **02**, as illustrated in FIG. **4b**;

**[0047]** (3) Manufacturing a layered structure **03** containing monochrome quantum dots on the planarization layer **05** which is formed by laminating flake graphene layers **031** and monochrome quantum dot layers **032** alternatively, as illustrated in FIG. **4c**;

**[0048]** (4) Forming a protection layer **04** on the layered structure **03** as illustrated in FIG. **4d**;

**[0049]** (5) Forming an upper polarization sheet **09** on the protection layer **04** as illustrated in FIG. **4e**;

**[0050]** (6) Forming a passivation layer **06** on the upper polarization sheet **09** as illustrated in FIGS. **4f**; and

**[0051]** (7) Forming pillar like spacers **07** (PS) on the passivation layer **06** as illustrated in FIG. **4g**.

[0052] For example, an embodiment of the present invention further provides a dispersing method of monocolour quantum dots as illustrated in FIG. 5, comprising the following steps:

[0053] S501. Forming a first flake graphene layer on a base substrate;

[0054] S502. Forming a pattern of monocolour quantum dots on the first flake graphene layer by a transferring print method;

[0055] S503. Forming a second flake graphene layer on the monocolour quantum dot layer.

[0056] For example, the first flake graphene layer in step S501 and the second flake graphene layer in step S503 may be formed according to the following steps:

[0057] (1) Mixing graphene powder, ethyl cellulose and organic solvent to obtain mixture solution.

[0058] The graphene powder accounts for 1%-10% mass percent with respect to the ethyl cellulose; a sum of graphene powder and ethyl cellulose accounts for 20%-50% mass percent with respect to the organic solvent.

[0059] For example, the organic solvent is ethanol, and of course may be other common organic solvent, which is not limited here.

[0060] For example, it is possible to add graphene powder and ethyl cellulose into the organic solvent first. Then, the organic solvent added with graphene powder and ethyl cellulose is placed in an oven, and a dissolution process is carried out under the condition of 80-100° C., preferably 90° C. Finally, after the graphene powder and ethyl cellulose are dissolved, the organic solvent with dissolved graphene powder and ethyl cellulose is subjected to ultrasonic processing to obtain the mixture solution.

[0061] (2) Coating the mixture solution onto a base substrate or a monocolour quantum dot layer, for example as illustrated in FIG. 6a, in which the mixture solution 08 is coated onto the base substrate 01.

[0062] (3) Removing the organic solvent and ethyl cellulose in the mixture solution with drying and heating to obtain the first flake graphene layer formed on the base substrate or the second flake graphene layer formed on the monocolour quantum dot layer. For example, as illustrated in FIG. 6b, the first flake graphene layer 0311 is formed on the base substrate 01.

[0063] For example, it is possible to put the base substrate coated with mixture solution into an oven under 80-100° C. for drying for 12 hours, preferably under 90° C. Then, the oven is heated to about 400° C. for heating for 8 hours. Finally, it is naturally cooled down to the room temperature. Now the graphite is gradually layered and transformed into a transparent state. Preferably, in order to prevent foreign particles from dropping into the graphene surface layer, for example, the above-mentioned steps may be carried out in a dustless circumstance.

[0064] For example, forming a pattern of monocolour quantum dot layer on the first flake graphene layer in step S502 may be implemented by the following steps:

[0065] (1) Dipping a transferring print plate 10 in the monocolour quantum dot solution 11, as illustrated in FIG. 6c.

[0066] For example, in the monocolour quantum dot solution, the content of monocolour quantum dots is 0.1-5 wt%, and the solvent may be cyclohexane or other solvent with high polarity, such as toluene, ethyl acetate or benzene. Further, in order to prevent monocolour quantum dots from aggregation,

the monocolour quantum dot solution may be subjected to ultrasonic dispersion for 3 hours first.

[0067] (2) On the first flake graphene layer 0311 of the base substrate 01, performing a transfer printing process with the transfer print plate 10 carrying monocolour quantum dot solution 11, as illustrated in FIGS. 6d and 6e.

[0068] (3) Drying the monocolour quantum dot solution 11 on the first flake graphene layer 0311 to obtain a pattern of monocolour quantum dot layer 032 on the first flake graphene layer 0311, as illustrated in FIG. 6f. For example, it is possible to dry it under 100° C. for about 3 hours.

[0069] Then, the above-mentioned steps are repeated to transfer patterns of different monocolour quantum dot layers on the first flake graphene layer 0311 at other locations, as illustrated in FIG. 6g.

[0070] Finally, the second flake graphene layer 0312 is formed on the monocolour quantum dot layer 032, as illustrated in FIG. 6h.

[0071] An embodiment of the present invention further provides a display device comprising the aforementioned liquid crystal display panel and driving circuits operating in cooperation with the liquid crystal display panel. Since this device solves problems with a principle similar to that of the aforementioned liquid crystal display panel, the implementation of liquid crystal display panel may be referred to for the implementation of the device, and repetitions will not be described further here.

[0072] With the color filter substrate, the liquid crystal display panel, the display device and the dispersing method of monocolour quantum dots provided in embodiments of the present invention, a layered structure containing monocolour quantum dots is provided in sub-pixel areas of at least one colors in the pixels on the color filter substrate. The layered structure is formed by laminating flake graphene layers and monocolour quantum dot layers alternatively, and both bottom and top layers of the layered structure are flake graphene layers. Monocolour quantum dots emit monochromatic light corresponding to the color of sub-pixels after being excited. In embodiments of the present invention, a layered structure containing monocolour quantum dots is used instead of conventional color resin as a color filter to convert background light into monochromatic light. Since quantum dots have narrow emission spectrum and high luminescence efficiency, they can efficiently convert background light into monochromatic light, which can enhance color gamut of the liquid crystal display panel, enhance the color saturation and improve display quality of the display screen. Also, the process of forming the layered structure by laminating flake graphene layers and monocolour quantum dot layers alternatively allows the monocolour quantum dots to be uniformly dispersed between adjacent flake graphene layers, prevents monocolour quantum dots from accumulating, and increases quantum yield of quantum dots to improve light efficiency of quantum excitation.

[0073] What are described above is related to the illustrative embodiments of the disclosure only and not limitative to the scope of the disclosure; the scopes of the disclosure are defined by the accompanying claims.

1. A dispersing method of monocolour quantum dots comprising:

forming a first flake graphene layer on a base substrate;

forming a pattern of monocolour quantum dots on the first flake graphene layer with transfer method; and

forming a second flake graphene layer on the monochrome quantum dot layer.

2. The method of claim 1, wherein forming of the first flake graphene layer or second flake graphene layer comprises:

mixing graphene powder, ethyl cellulose and organic solvent to obtain a mixture solution;

coating the mixture solution onto the base substrate or the monochrome quantum dot layer; and

removing the organic solvent and ethyl cellulose in the mixture solution by drying to obtain the first flake graphene layer formed on the base substrate or the second flake graphene layer formed on the monochrome quantum dot layer.

3. The method of claim 2, wherein the graphene powder accounts for 1%-10% mass percent with respect to the ethyl cellulose; a sum of the graphene powder and the ethyl cellulose accounts for 20%-50% mass percent with respect to the organic solvent.

4. The method of claim 2, wherein the organic solvent is ethanol.

5. The method of claim 1, wherein forming of the pattern of monochrome quantum dots on the first flake graphene layer comprises:

dipping a transfer print plate in the monochrome quantum dot solution;

performing transfer printing with the transfer print plate carrying monochrome quantum dot solution on the first flake graphene layer of the base substrate; and

drying the monochrome quantum dot solution on the first flake graphene layer to obtain the pattern of monochrome quantum dot layer formed on the first flake graphene layer.

6. The method of claim 3, wherein the organic solvent is ethanol.

7. The method of claim 2, wherein mixing graphene powder, ethyl cellulose and organic solvent to obtain the mixture solution comprises:

adding graphene powder and ethyl cellulose into the organic solvent;

placing the organic solvent added with graphene powder and ethyl cellulose in an oven, and carrying out a dissolution process under a condition of 80-100° C.; and

subjecting the organic solvent with dissolved graphene powder and ethyl cellulose to ultrasonic processing to obtain the mixture solution.

8. The method of claim 7, wherein carrying out a dissolution process under a condition of 90° C.

9. The method of claim 2, wherein the step of removing the organic solvent and ethyl cellulose in the mixture solution by drying to obtain the first flake graphene layer formed on the base substrate or the second flake graphene layer formed on the monochrome quantum dot layer is carried out in a dustless circumstance.

10. The method of claim 5, wherein in the monochrome quantum dot solution, a content of monochrome quantum dots is 0.1-5 wt%.

11. The method of claim 5, wherein before dipping the transfer print plate in the monochrome quantum dot solution, the monochrome quantum dot solution is subjected to ultrasonic dispersion.

\* \* \* \* \*