



US 20150190300A1

(19) **United States**

(12) **Patent Application Publication**
HARDMAN et al.

(10) **Pub. No.: US 2015/0190300 A1**

(43) **Pub. Date: Jul. 9, 2015**

(54) **FOOT MANIFOLDS, APPARATUSES, SYSTEMS, AND METHODS FOR APPLYING REDUCED PRESSURE TO A TISSUE SITE ON A FOOT**

(60) Provisional application No. 61/036,433, filed on Mar. 13, 2008.

Publication Classification

(71) Applicant: **KCI Licensing, Inc.**

(51) **Int. Cl.**
A61H 9/00 (2006.01)

(72) Inventors: **IAN JAMES HARDMAN**,
Bournemouth (GB); **Colin John Hall**,
Poole (GB)

(52) **U.S. Cl.**
CPC **A61H 9/0057** (2013.01); **A61H 2201/164**
(2013.01)

(21) Appl. No.: **14/664,529**

(57) **ABSTRACT**

(22) Filed: **Mar. 20, 2015**

Apparatuses, systems, and methods for applying reduced pressure to a tissue site on a foot are provided. An apparatus may include an insole and a tissue contacting surface covering at least a portion of the insole. At least one portion of the tissue contacting surface is removable to form a void. The apparatus may also include a reduced-pressure interface for receiving reduced pressure from a reduced-pressure source, and at least one flow channel fluidly coupled to the reduced-pressure interface and the void.

Related U.S. Application Data

(63) Continuation of application No. 13/655,210, filed on Oct. 18, 2012, now Pat. No. 9,011,353, which is a continuation of application No. 12/404,111, filed on Mar. 13, 2009, now Pat. No. 8,313,449.

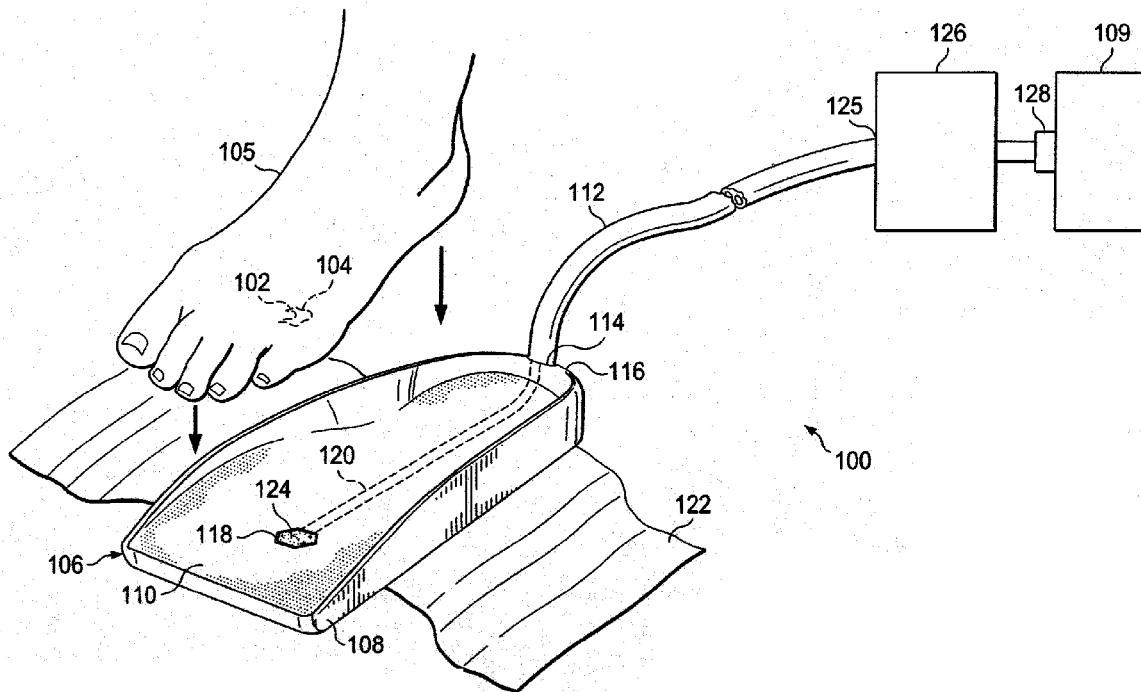

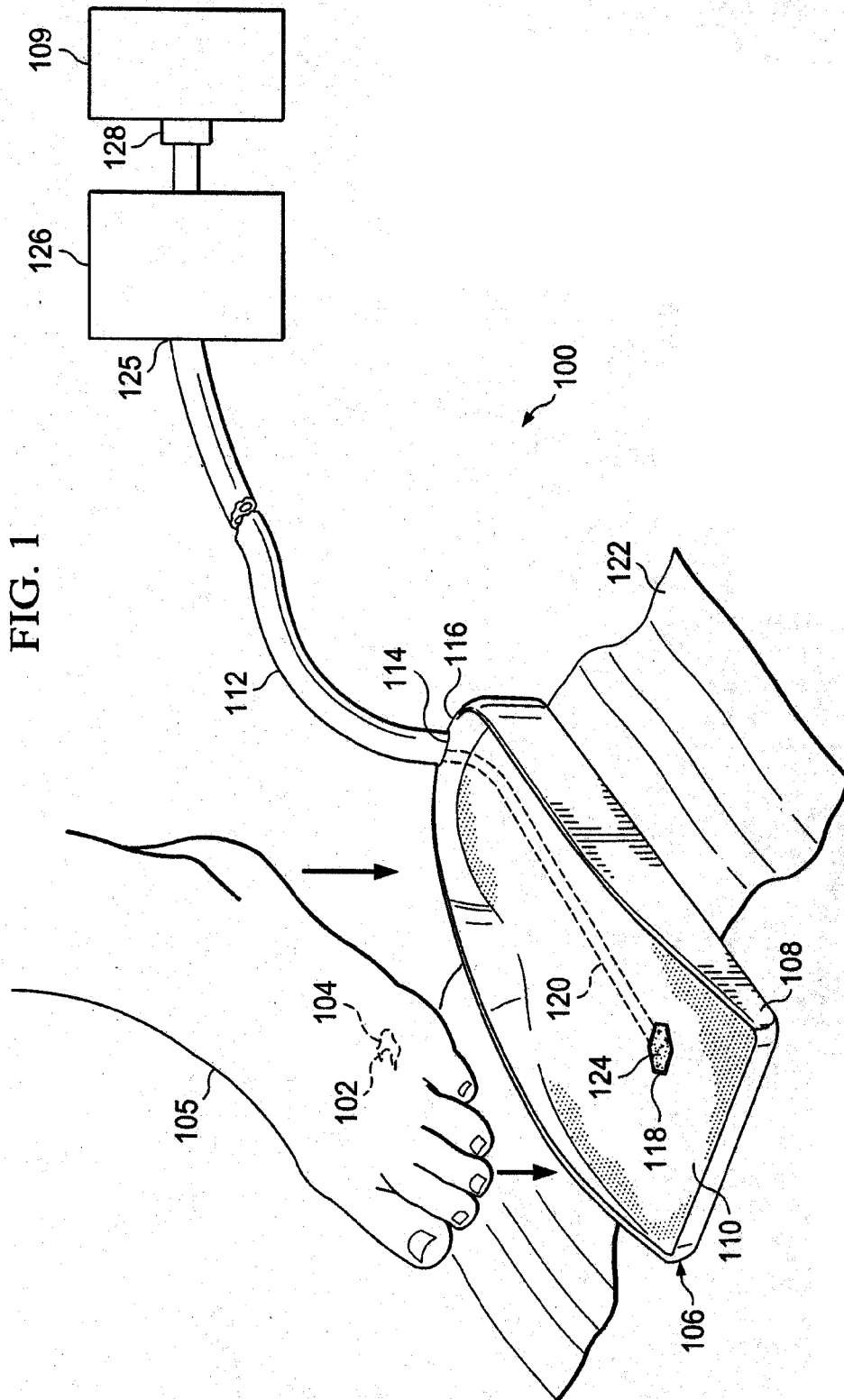

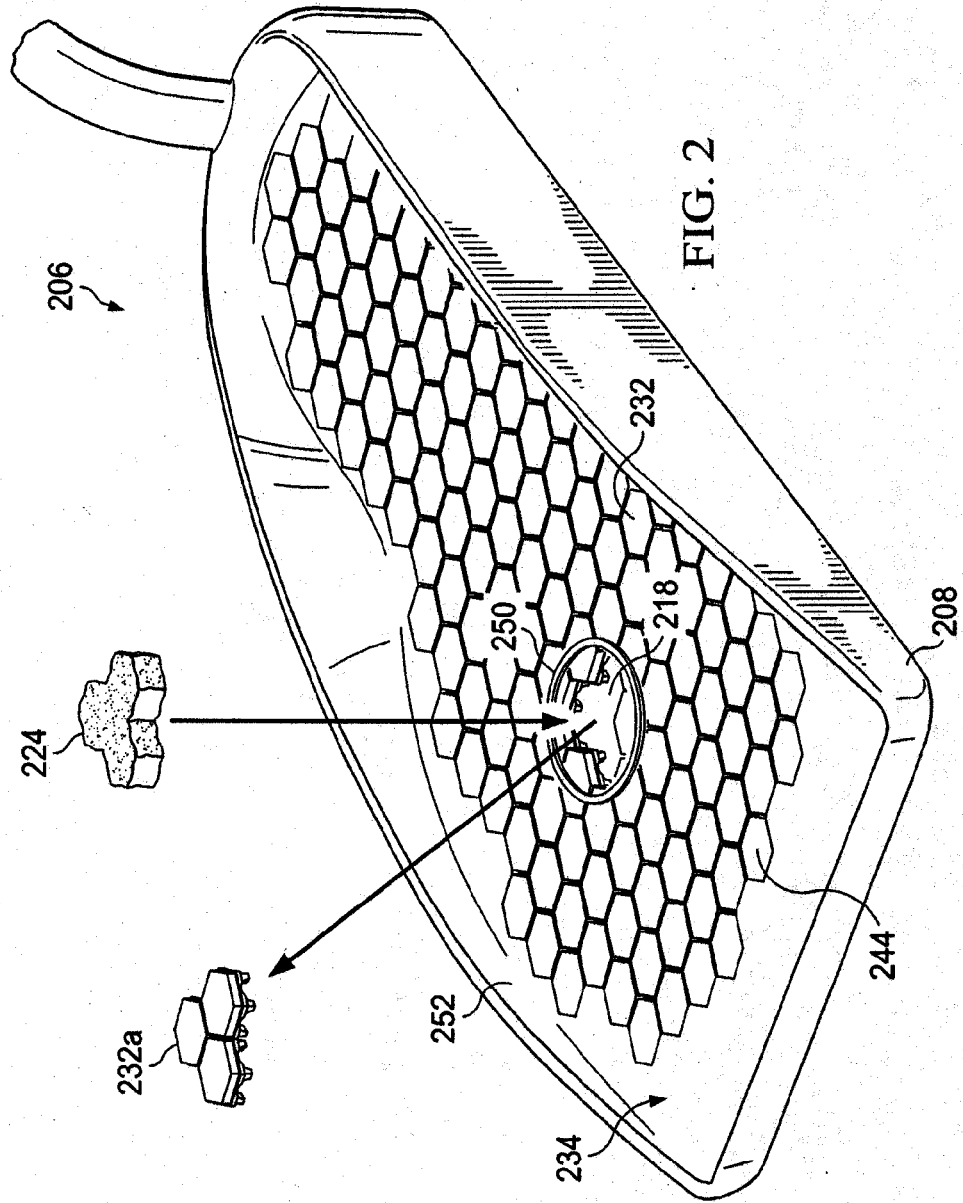

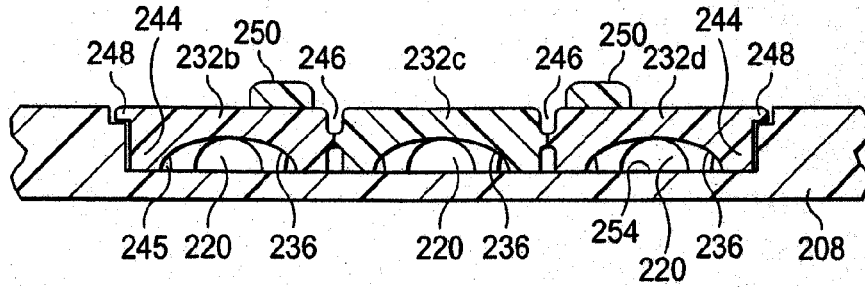

FIG. 3A

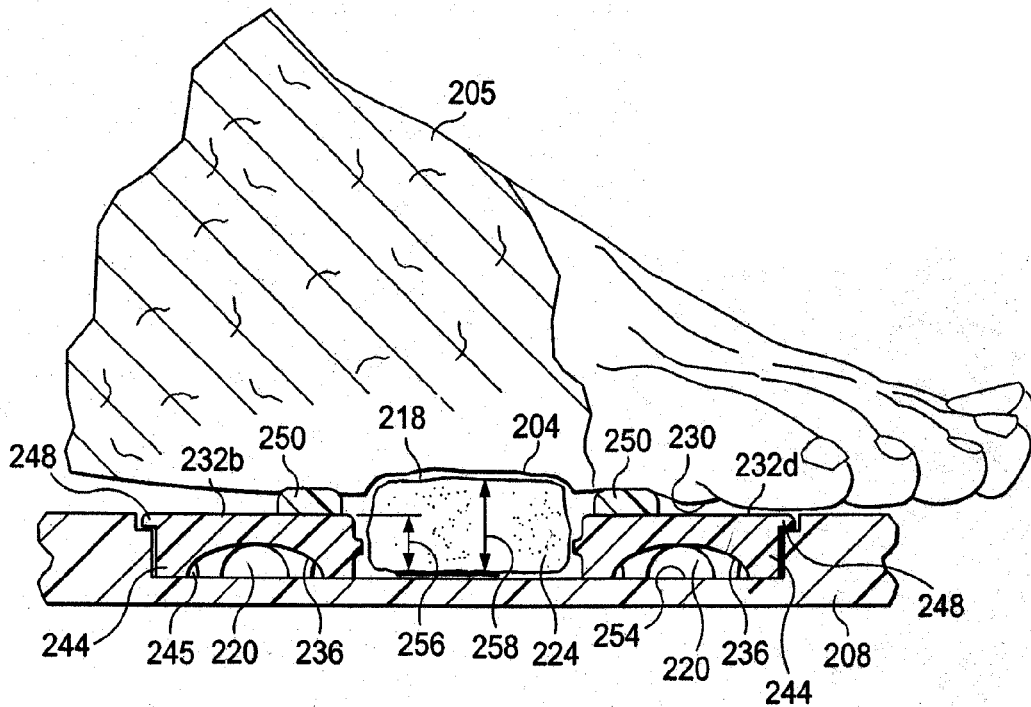
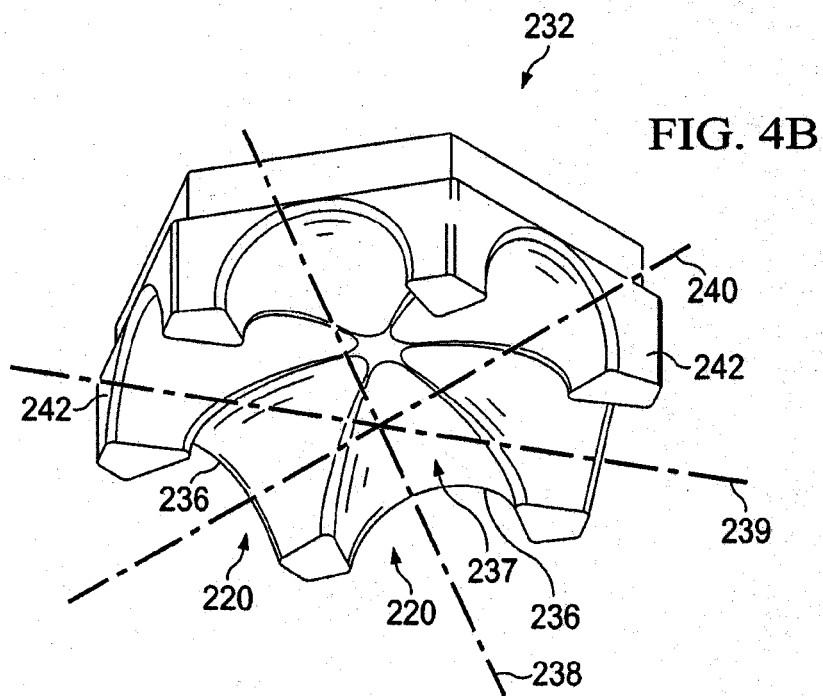
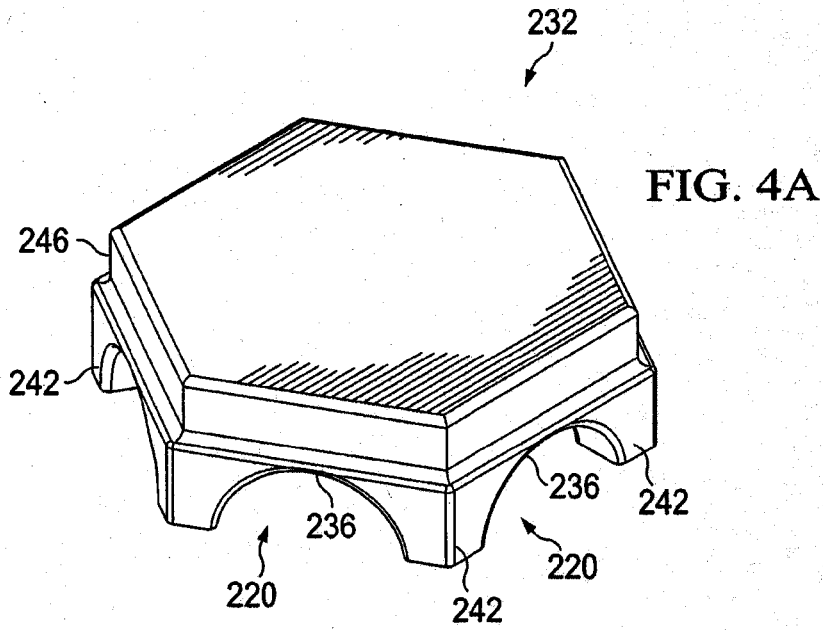
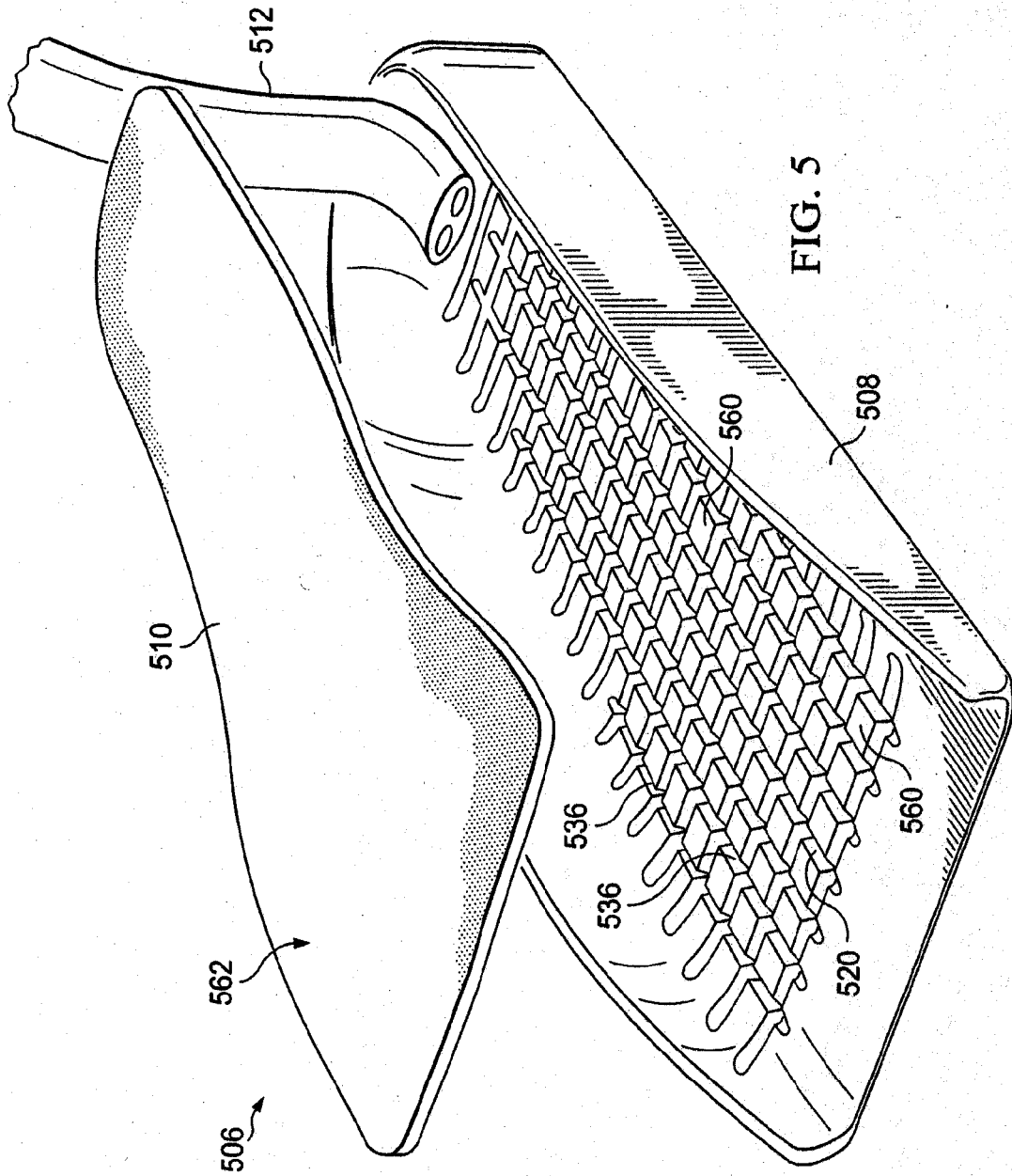
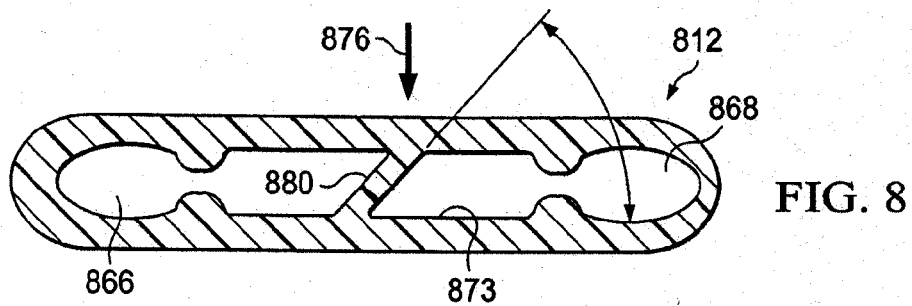
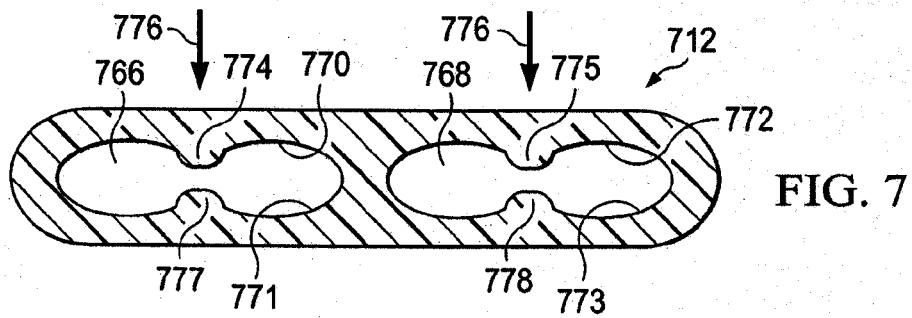
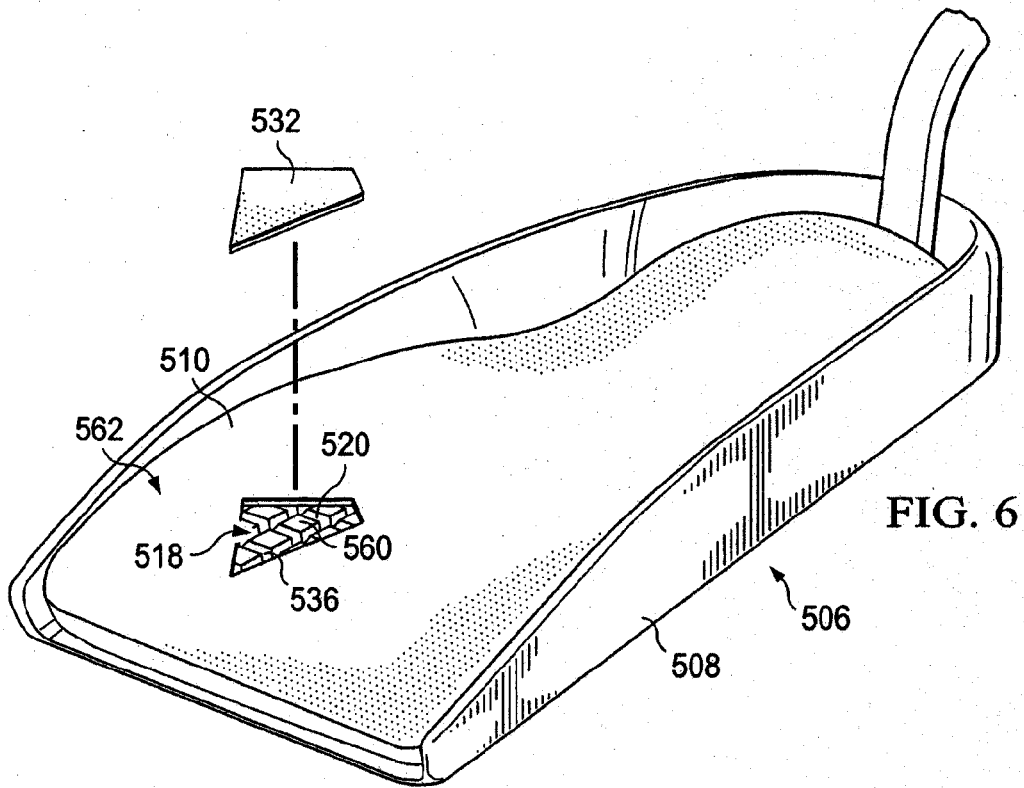

FIG. 3B







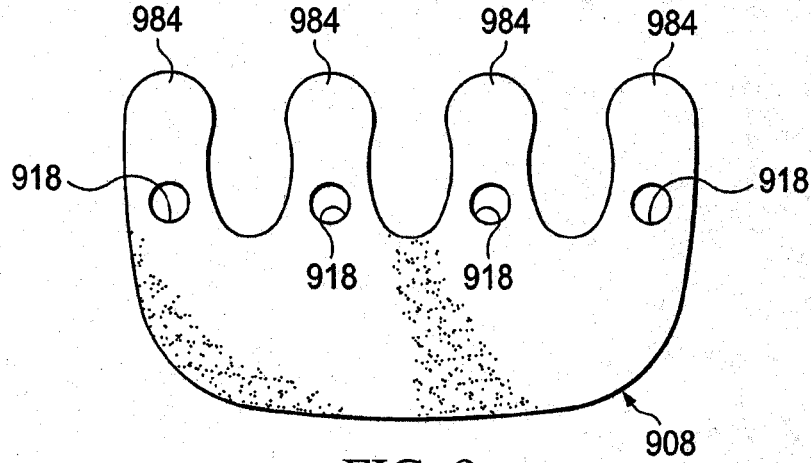

FIG. 9

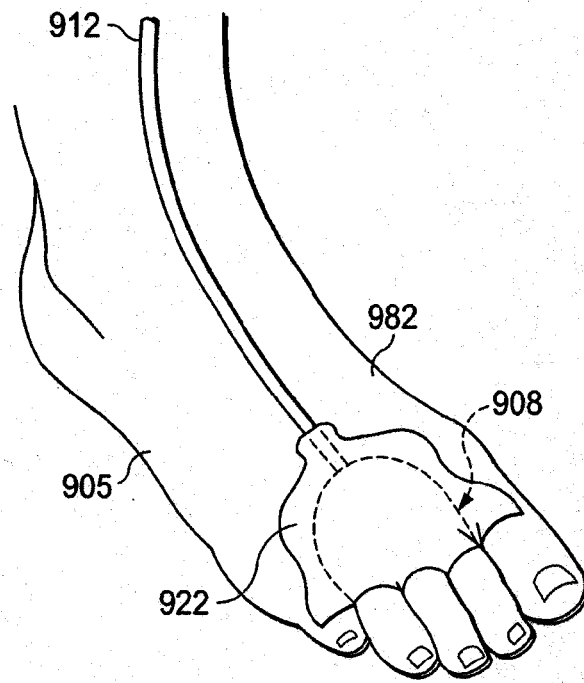

FIG. 10

**FOOT MANIFOLDS, APPARATUSES,
SYSTEMS, AND METHODS FOR APPLYING
REDUCED PRESSURE TO A TISSUE SITE ON
A FOOT**

CROSS-REFERENCE TO RELATED
APPLICATIONS

[0001] This application is a continuation of U.S. patent application Ser. No. 13/655,210, filed Oct. 18, 2012, which is a continuation of U.S. patent application Ser. No. 12/404,111, filed Mar. 13, 2009, which application claims the benefit of U.S. Provisional Application No. 61/036,433 filed Mar. 13, 2008, which is hereby incorporated by reference.

BACKGROUND

[0002] The illustrative embodiments relate generally to medical treatment systems and, more particularly, to foot manifolds, apparatuses, systems, and methods for applying reduced pressure to a tissue site on a foot.

[0003] Clinical studies and practice have shown that providing a reduced pressure in proximity to a tissue site augments and accelerates the growth of new tissue at the tissue site. The applications of this phenomenon are numerous, but application of reduced pressure has been particularly successful in treating wounds. This treatment (frequently referred to in the medical community as “negative pressure wound therapy,” “reduced pressure therapy,” or “vacuum therapy”) provides a number of benefits, which may include faster healing and increased formulation of granulation tissue.

SUMMARY

[0004] According to an illustrative embodiment, an apparatus for applying reduced pressure to a tissue site on a foot includes an insole and a tissue contacting surface covering at least a portion of the insole. At least one portion of the tissue contacting surface is removable to form a void. The apparatus may also include a reduced-pressure interface for receiving reduced pressure from a reduced-pressure source, and at least one flow channel fluidly coupled to the reduced-pressure interface and the void.

[0005] In one illustrative embodiment, a system may include, in addition to the apparatus described above, a reduced-pressure source operable to supply reduced pressure. The system may also include a delivery conduit operable to deliver reduced pressure from the reduced-pressure source to the reduced-pressure interface of the apparatus.

[0006] In one illustrative embodiment, a method for applying reduced pressure to a tissue site on a foot includes providing a foot manifold and removing a portion of a tissue contacting surface that covers an insole of the foot manifold to form a void. The method also includes aligning the void with the tissue site on the foot and creating a substantially pneumatic seal between the void and the tissue site. The method also includes applying reduced pressure from a reduced-pressure source to the void via a flow channel such that reduced pressure is applied to the tissue site.

[0007] In one illustrative embodiment, a method of manufacturing an apparatus for applying reduced pressure to a tissue site on a foot includes providing an insole and providing a tissue contacting surface. The method also includes covering at least a portion of the insole with the tissue contacting surface to form at least one flow channel operable to transfer reduced pressure.

[0008] Other objects, features, and advantages of the illustrative embodiments will become apparent with reference to the drawings and detailed description that follow.

BRIEF DESCRIPTION OF THE DRAWINGS

[0009] FIG. 1 illustrates a perspective view of a system for applying reduced pressure to a tissue site on a foot according to an illustrative embodiment;

[0010] FIG. 2 illustrates a perspective view of an apparatus for applying reduced pressure to a tissue site on a foot according to an illustrative embodiment;

[0011] FIG. 3A illustrates a cross-sectional view of the apparatus of FIG. 2;

[0012] FIG. 3B illustrates a cross-sectional view of the apparatus of FIG. 2, the apparatus having a support member removed to form a void;

[0013] FIG. 4A illustrates a top perspective view of a support member of the apparatus of FIG. 2;

[0014] FIG. 4B illustrates a bottom perspective view of the support member of FIG. 4A;

[0015] FIG. 5 illustrates an exploded perspective view of an apparatus for applying reduced pressure to a tissue site on a foot according to an illustrative embodiment;

[0016] FIG. 6 illustrates a perspective view of the apparatus of FIG. 5 with a portion of a sealing layer removed to form a void;

[0017] FIG. 7 illustrates a cross-sectional view of a delivery conduit according to an illustrative embodiment;

[0018] FIG. 8 illustrates a cross-sectional view of a delivery conduit according to an illustrative embodiment;

[0019] FIG. 9 illustrates a top view of an apparatus for applying reduced pressure to a tissue site on a foot according to an illustrative embodiment; and

[0020] FIG. 10 illustrates a perspective view of the apparatus of FIG. 9 applied to a tissue site on a foot according to an illustrative embodiment.

DETAILED DESCRIPTION

[0021] In the following detailed description of the illustrative embodiments, reference is made to the accompanying drawings that form a part hereof. These embodiments are described in sufficient detail to enable those skilled in the art to practice the invention, and it is understood that other embodiments may be utilized and that logical structural, mechanical, electrical, and chemical changes may be made without departing from the spirit or scope of the invention. To avoid detail not necessary to enable those skilled in the art to practice the embodiments described herein, the description may omit certain information known to those skilled in the art. The following detailed description is, therefore, not to be taken in a limiting sense, and the scope of the illustrative embodiments are defined only by the appended claims.

[0022] Referring to FIG. 1, an illustrative embodiment of a reduced-pressure treatment system 100 for providing reduced-pressure treatment to a tissue site 102, such as a wound 104, on a foot 105 of a patient is presented. The reduced-pressure treatment system 100 includes a foot manifold 106 that receives reduced pressure from a reduced-pressure source 109, and which supplies reduced pressure to a tissue site on the foot 105. The foot manifold 106 includes an insole 108, and a tissue contacting surface 110 that covers the tissue facing surface of the insole 108. As used herein, “covers” includes fully or partially covering. The reduced pressure

may be delivered to the foot manifold **106** through a delivery conduit **112**, which may be inserted, or otherwise removably coupled, to a reduced-pressure interface **114** located at the rear **116** of the insole **108**. A portion of the tissue contacting surface **110** is removable to form a void **118**, which may be aligned with the wound **104** when the foot manifold **106** and foot **105** are adjacent. One or more flow channels **120** in the insole **108** transfers reduced pressure from the reduced-pressure interface **114** to the void **118** such that reduced-pressure treatment is delivered to the wound **104**.

[0023] As used herein, “reduced pressure” generally refers to a pressure less than the ambient pressure at a tissue site that is being subjected to treatment. In most cases, this reduced pressure will be less than the atmospheric pressure at which the patient is located. Alternatively, the reduced pressure may be less than a hydrostatic pressure at the tissue site. In one embodiment, the reduced pressure may initially generate fluid flow in the delivery conduit **112** and proximate the wound **104**. As the hydrostatic pressure around the wound **104** approaches the desired reduced pressure, the flow may subside, and the reduced pressure may be maintained. Unless otherwise indicated, values of pressure stated herein are gauge pressures. The reduced pressure delivered may be static or dynamic (patterned or random) and may be delivered continuously or intermittently. Although the terms “vacuum” and “negative pressure” may be used to describe the pressure applied to the tissue site, the actual pressure applied to the tissue site may be more than the pressure normally associated with a complete vacuum. Consistent with the use herein, an increase in reduced pressure or vacuum pressure typically refers to a relative reduction in absolute pressure. Unless otherwise indicated, as used herein, “or” does not require mutual exclusivity.

[0024] The wound **104** may be any type of wound, or damaged area of tissue, and may include wounds from trauma, surgery, or other causes, such as a diabetic ulcer. The tissue site **102**, which includes the wound **104**, may be the bodily tissue of any human, animal, or other organism, including bone tissue, adipose tissue, muscle tissue, dermal tissue, vascular tissue, connective tissue, cartilage, tendons, ligaments, or any other tissue. Treatment of the tissue site **102** may include removal of fluids, e.g., exudate, or delivery of reduced pressure.

[0025] In the example in which the wound **104** is a foot ulcer, the insole **108** may also serve to off-load pressure from the wound **104**, such as when the patient is walking or standing. The tissue contacting surface **110** may maintain contact with the tissue around the wound **104**, thereby relieving pressure from the wound **104**. The pressure exerted upon the wound **104** is reduced due to the presence of the void **118** adjacent the wound **104**. In particular, because the portion of the tissue contacting surface **110** that is adjacent the wound **104** is removed, the pressure exerted upon the wound **104** is reduced.

[0026] The foot manifold **106** may be used in conjunction with or in lieu of therapeutic casting systems, such as total contact casting and removable cast walkers. For example, the foot manifold **106** may be placed into a therapeutic casting system that is worn by the patient. In another example, the foot manifold **106** may be inserted into any article of footwear, such as a shoe, boot, sandal, or sock.

[0027] The foot manifold **106** may also be secured to the foot **105** in other ways. For example, a securing member **122** may be at least partially wrapped around the insole **108** and

the foot **105**. Adhesive may be used to prevent the securing member **122** from unwrapping. If desired, the foot **105** and the foot manifold **106** that have been wrapped by the securing member **122** may be placed in footwear, including a therapeutic casting system. The foot manifold **106** may also be secured to the foot **105** using one or more elastic bands that press the foot manifold **106** and foot **105** against one another.

[0028] In another example, the foot manifold **106** may adhere to the foot **105** without the need for the securing member **122** or footwear. In this example, the tissue contacting surface **110** of the foot manifold **106** may be made from or coated with an adhesive material that secures the foot **105** to the foot manifold **106**.

[0029] A foam manifold **124** may be inserted into the void **118**. The foam manifold **124** assists in applying reduced pressure to, delivering fluids to, or removing fluids from the wound **104**. The foam manifold **124** typically includes a plurality of flow channels or pathways that are interconnected to improve distribution of fluids provided to and removed from the wound **104** adjacent the foam manifold **124**. The foam manifold **124** may be a biocompatible material that is capable of being placed in contact with the wound **104** and distributing reduced pressure to the wound **104**. Examples of foam manifolds **124** may include, for example, without limitation, devices that have structural elements arranged to form flow channels, such as, for example, cellular foam, open-cell foam, porous tissue collections, liquids, gels, and foams that include, or cure to include, flow channels. The foam manifold **124** may be porous and may be made from foam, gauze, felted mat, or any other material suited to a particular biological application. In one embodiment, the foam manifold **124** is a porous foam and includes a plurality of interconnected cells or pores that act as flow channels. The porous foam may be a polyurethane, open-cell, reticulated foam, such as a Granu-Foam® material manufactured by Kinetic Concepts, Incorporated of San Antonio, Tex. In some situations, the foam manifold **124** may also be used to distribute fluids, such as medications, antibacterials, growth factors, and various solutions to the wound **104**. Other layers may be included in or on the foam manifold **124**, such as absorptive materials, wicking materials, hydrophobic materials, and hydrophilic materials.

[0030] Reduced pressure is delivered to the void **118** through the flow channel **120**. Although the foot manifold **106** is shown to have only a single flow channel **120**, the foot manifold **106** may have any number of flow channels, such as flow channel **120**, that are able to fluidly connect any portion of the insole **108** or tissue contacting surface **110** with the reduced-pressure interface **114**. As described in the figures below, these flow channels may be interconnected, form any pattern, or defined by one or more grooves on the insole **108** or the tissue contacting surface **110**. The flow channel **120** may also be a tube or conduit that fluidly couples the reduced-pressure interface **114** to the void **118**.

[0031] Reduced pressure is delivered to the flow channel **120** via the reduced-pressure interface **114**. The reduced-pressure interface **114** may be any socket, port, hole, or other attachment capable of facilitate coupling, including the fluid coupling, between the delivery conduit **112** and the foot manifold **106**. As used herein, the term “coupled” includes coupling via a separate object and includes direct coupling. The term “coupled” also encompasses two or more components that are continuous with one another by virtue of each of the components being formed from the same piece of material. Also, the term “coupled” may include chemical, such as via a

chemical bond, mechanical, thermal, or electrical coupling. Fluid coupling means that fluid is in communication between the designated parts or locations.

[0032] In one non-limiting example, the reduced-pressure interface 114 may include a hole into which the delivery conduit 112 may be inserted, thereby forming an interference fit. Upon insertion of the delivery conduit 112 into the reduced-pressure interface 114, reduced pressure may be delivered to the flow channel 120 and the void 118 from the reduced-pressure source 109. A mechanism may also be used to secure the delivery conduit 112 to the reduced-pressure interface 114 to prevent the delivery conduit 112 from being pulled out of the reduced-pressure interface 114. In one embodiment, the delivery conduit 112 is integrally formed with the reduced-pressure interface 114 such that the delivery conduit 112 is fixedly coupled to the reduced-pressure interface 114. The reduced-pressure interface 114 may also include a swivel, hinge, or other movable attachment mechanism to permit the delivery conduit 112 to move or swivel relative to the insole 108.

[0033] The delivery conduit 112 may include one or more lumens through which a fluid may flow. In one embodiment, the delivery conduit 112 includes two or more lumens, any of which may be used to transfer reduced pressure to the foot manifold 106, transfer liquid, such as exudate, away from the foot manifold 106, or transfer therapeutic fluids to the foot manifold 106.

[0034] The reduced-pressure source 109 provides reduced pressure to the foot manifold 106. The reduced-pressure source 109 may be any means of supplying a reduced pressure, such a vacuum pump. While the amount and nature of reduced pressure applied to a site will typically vary according to the application, the reduced pressure will typically be between -5 mm Hg and -500 mm Hg.

[0035] A medial portion 125 of the delivery conduit 112 may have one or more devices, such as device 126. For example, the device 126 might be another fluid reservoir, or collection member to hold exudates and other fluids removed. Other examples of the device 126 that might be included on the medial portion 125 of the delivery conduit 112 or otherwise fluidly coupled to the delivery conduit 112 include the following non-limiting examples: a pressure-feedback device, a volume detection system, a blood detection system, an infection detection system, a flow monitoring system, a temperature monitoring system, etc. Some of these devices may be formed integral to the reduced-pressure source 109. For example, a reduced-pressure port 128 on the reduced-pressure source 109 may include a filter member that includes one or more filters, e.g., an odor filter.

[0036] In use, a patient or caretaker may remove a portion of the tissue contacting surface 110 to form the void 118. The portion of the tissue contacting surface 110 that is removed is detachably mated to the insole 108, and may be chosen such that the void 118 aligns, or is otherwise adjacent, the wound 104 when the foot manifold 106 and the foot 105 are adjacent one another. Grid lines or markers may be included on the tissue contacting surface 110 to assist in choosing the appropriate portion of the tissue contacting surface 110 for removal. The foam manifold 124 may be inserted into the void 118. When in use, the foot 105 and the foot manifold 106 are disposed adjacent one another to create a substantially pneumatic seal between the void 118 and the wound 104. As described below, the substantially pneumatic seal may be facilitated in variety of ways, including through the use of a

sealing member (not shown) or the tissue contacting layer 110 itself. Reduced pressure may then be applied to the foot manifold 106 from the reduced-pressure source 109. The reduced pressure may be transferred through the delivery conduit 112 and into the void 118 via the reduced-pressure interface 114 and the flow channel 120, thereby providing reduced-pressure treatment to the wound 104. The substantially pneumatic seal formed at the wound 104 helps to maintain the reduced pressure at therapeutic levels.

[0037] Referring to FIGS. 2, 3A-B, and 4A-B, an illustrative embodiment of the foot manifold 206 includes the insole 208. The foot manifold 206 also includes support members 232, which are functionally analogous to the tissue contacting surface 110 in FIG. 1.

[0038] In one embodiment, the insole 208 is shaped and sized to approximate the plantar region 230 of the foot 205, but may also cover only a portion of the plantar region 230, such as the heel region. The insole 208 may also cover all or a portion of the dorsal region, toes, sides, or rear of the foot 205. The insole 208 includes a ridge 252, which may help to secure the foot 205 to the foot manifold 206 and prevent movement of the insole 208 relative to the foot 205 or the wound 204. In another example, the insole 208 does not have the ridge 252.

[0039] The insole 208 may be formed from any material. For example, the insole 208 may be composed of a flexible or elastic material, such as silicon, polyurethane, or a thermoplastic elastomer. The flexible or elastic composition of the insole 208 may also facilitate the insertion of the insole 208 into an article of footwear.

[0040] The support members 232 form a layer that covers a tissue facing surface 234 of the insole 208. The support members 232 contact the plantar region 230 of the foot 205, and may provide an off-loading function that can reduce the pressure exerted on the wound 204. Although shown as hexagonal, the support members 232 may have any shape, including, without limitation, a square, rectangle, triangle, octagon, polygon, circle, oval, or irregular shape.

[0041] The flow channels 220 are disposed between the support members 232 and the insole 208, and are formed by a tissue facing surface 254 of the insole 208 and the grooves 236 on the insole-facing side 237 of the support members 232. The grooves 236 may be formed along three axes 238, 239, 240. Each side 242 of the support member 232 may include a groove 236. However, some support members 232, such as those support members on the periphery 244 of the layer formed by the support members 232, may have sides 242 that do not include a groove 236. When the support members 232 cover the insole 208, the grooves 236 form an interconnected network of flow channels 220 that distributes reduced pressure along the interface 245 between the support members 232 and the insole 208. The support members 232 comes into contact with the insole 208, or may be coupled to the insole 208 using any known technique, including without limitation welding (e.g., ultrasonic or RF welding), bonding, adhesives, cements, etc. In one embodiment, the support members 232 are coupled to the insole 208 to seal the flow channels 220 and keep reduced pressure from leaking out of the flow channels 220 leading to the void 218.

[0042] In one embodiment, the grooves 236 are arch-shaped grooves. However, the grooves 236 may have any shape. For example, the grooves 236 may have one or more

straight side walls such that, when the support member 232 is coupled to the insole 208, an at least partially polygonal flow channel is formed.

[0043] The support members 232 may include one or more insertion slots 246. The insertion slots 246 may be adapted to receive a device that facilitates the removal of each of the support members 232, such as a scalpel. The insertion slots 246 may have any shape, and the shape may depend upon the type of device to be used in the removal of the support members 232.

[0044] The support members 232 at the periphery 244 include lap joints 248. In one example, the lap joints 248 are included only on those support members 232 on the periphery 244 of the layer formed by the support members 232. The lap joints 248 facilitate a sealed connection between the support members 232 and the insole 208. Although the lap joints 248 are shown to be polygonal protrusions, the lap joints 248 may also be rounded protrusions or any other protrusion that can facilitate a sealed connection between the support members 232 and the insole 208.

[0045] The support members 232 may also be made of any material capable of supporting the foot 205. For example, each of the support members 232 may be made of elastic, flexible, or soft materials. The elastic qualities of the support members 232 may lessen the pressure exerted upon the tissue site. Non-limiting examples of the material from which the support members 232 may be composed include silicon (including soft, conformable silicon), polyurethane, and a thermoplastic elastomer (TPE).

[0046] Any one or more of the support members 232 may be removed to form the void 218. In FIG. 2, support members 232a are removed to form the void 218. The support members 232a may be chosen based on their location on the insole 208 such that the wound 204 is adjacent the void 218 when the foot 205 is placed adjacent the foot manifold 206. Markers, such as characters, may be included on the support members 232 to help locate the support members 232a that align with the wound 204. A sealing member 250 may be disposed around the void 218 and between the foot 205 and the support members 232 when the foot 205 is applied to the foot manifold 206. The foot 205 may be positioned on the sealing ring 250 and the support members 232 such that a seal is formed at the void 218. The seal that is formed by the sealing member 250 helps to prevent the escape of reduced pressure from the void 218 such that a therapeutic reduced pressure may be maintained at the void 218 and applied to the wound 204.

[0047] The sealing member 250 may have any shape and may be made of any material that helps to form a seal at the void 218. For example, the sealing member 250 may be a hydrogel ring. The sealing member 250 may also be formed from putty, silicon, closed cell polymer foam, TPE, or a soft, flexible, elastic, or adhesive material.

[0048] Upon removing the support members 232a, the void 218 may be fully or partially filled with the foam manifold 224. Before placement into the void 218, the foam manifold 224 may be smaller, larger, or approximately equal in volume to the void 218. The shape of the foam manifold 224 may also be any predetermined shape, or customized to fit the void 218. Also, the foam manifold 224, once inserted into the void 218, may expand to fill the void 218, and may press against the insole 208 or the support members 232 adjacent the void 218.

[0049] In one embodiment, the foam manifold 224 may be torn or cut from a foam sheet. The foam sheet may also be pre-cut to include foam manifold 224 that approximate the

size of the void 218, or the size of the support member 232. In an alternate embodiment, the foam manifold 224 may be placed into or on the wound 204 prior to applying the foot 205 to the foot manifold 206. In another embodiment, no foam manifold 224 need be used when treating the wound 204 with reduced pressure.

[0050] The foam manifold 224 in the void 218 may have a height 256 that approximates the height of the support members 232. The foam manifold 224 may also have a height 258 that is greater than the height of the support members 232, and which may touch the wound 204. In another embodiment, the foam manifold 224 is shorter than the height 256 of the support member 232.

[0051] In FIG. 3B, support member 232c, which is disposed between support members 232b and 232d in FIG. 3A, has been removed to form the void 218. Reduced pressure that is applied to the foot manifold 206 passes through the interconnected flow channels 220 formed by the grooves 236 and the tissue facing surface 254 of the insole 208 to reach the void 218. As explained above, the sealing member 250 may be used to create a seal at the void 218 such that a therapeutic reduced pressure is maintained at the void 218 and applied to the wound 204. In the illustrative embodiments, reduced pressure may be applied only to those portions of the foot 205 at which reduced-pressure treatment is desired, while supporting the remainder of the foot 205 using the support members 232.

[0052] Referring to FIGS. 5 and 6, a foot manifold 506 that includes a sealing layer 510 is shown according to an illustrative embodiment. The sealing layer 510 is functionally analogous to the tissue contacting layer 110 in FIG. 1. The sealing layer 510 is bonded, or otherwise coupled, to the insole 508, and covers all or a portion of the insole 508.

[0053] The insole 508 includes a flow channels 520, which are interconnected and formed by grooves 536 and protrusions 560 in the insole 508. The flow channels 520 form a grid. However, the flow channels 520 may form any pattern, including irregular patterns or no pattern at all. The flow channels 520 are further defined by an insole-contacting side of the sealing layer 510 when the sealing layer 510 abuts the insole 508. Reduced pressure may be provided to the flow channels 520 via the delivery conduit 512.

[0054] The sealing layer 510 may be composed of any material. For example, the sealing layer 510 may be composed of a flexible material that is capable of providing a sealed connection between the sealing layer 510 and the insole 508. In one non-limiting example, the sealing layer 510 may be a hydrogel layer. The tissue-facing side 562 or the insole-facing side of the sealing layer 510 may be adhesive. Adherence between the tissue-facing side 562 of the sealing layer 510 and the foot 105 may help to secure the foot 105 to the foot manifold 506.

[0055] A portion 532 may be identified, cut, and removed from the sealing layer 510 to form the void 518. The portion 532 may be removed using any device capable of cutting the sealing layer 510, such as a scalpel. A foam manifold may be inserted into the void 518. A foot may be disposed on top of the sealing layer 510 such that a tissue site, such as a wound, on the foot abuts the void 518. Reduced pressure may be transferred to the flow channels 520 via the delivery conduit 512, and the reduced pressure may be transferred through the flow channels 520 to the void 518.

[0056] The sealing characteristics of the sealing layer 510 help to prevent reduced pressure that is transferred to the void

518 from escaping, thereby maintaining a therapeutic reduced pressure for the tissue site abutting the void **518**. The sealing layer **510** may thus eliminate the need for a sealing member. Using the sealing layer **510**, the void **518** may be located anywhere on the sealing layer **510**, and the portion **532** of the sealing layer **510** that is removed to form the void **518** may have any shape. The location and shape of the removed portion **532** may be determined based on a location and shape of a wound on a foot, such as a foot ulcer. Grid markers, such as grid lines, may be printed, or otherwise included, on the sealing layer **510** to help identify the portion of the sealing layer **510** that should be removed to align the void **518** with a wound on a foot. The grid markers may also help to determine the healing progress of the wound as the sealing layer **510** is replaced during overall treatment of the wound.

[0057] Referring to FIG. 7, a delivery conduit **712** that is functionally analogous to the delivery conduit **112** in FIG. 1 is shown according to an illustrative embodiment. The delivery conduit **712** has an elongated shape having a low profile. The elongated shape of the delivery conduit **712** alleviates the pressure points applied to the portions of the foot, ankle, or leg that are adjacent the delivery conduit **712**. The delivery conduit **712** may also have other shapes, such as a circular, elliptical, polygonal, or curved “U” shape.

[0058] The delivery conduit **712** may also be made of any material, such as a flexible, elastic, or compressible material. The flexible, elastic, or compressible material may alleviate the pressure points applied to adjacent portions of the foot, ankle, or leg. Non-limiting examples of material from which the delivery conduit **712** may be formed include plastic, nylon, silicon, polyurethane, TPE, or PVC.

[0059] The delivery conduit **712** includes two lumens **766**, **768**. In one example, the lumens **766**, **768** transfer reduced pressure to one or more flow channels in a foot manifold. The delivery conduit **712** may have any number of lumens, including three or more lumens. In addition, one or more of the lumens in the delivery conduit **712** may be used to transport fluid, such as liquid or exudate, from a wound to a fluid collection apparatus. In other embodiments, the lumens **766**, **768** may have any shape, such as a circular, elliptical, or polygonal shape.

[0060] The lumen **766** is bound by a first wall **770** and a second wall **771**. Similarly, the lumen **768** is bound by a first wall **772** and a second wall **773**. The first walls **770**, **772** include protrusions **774**, **775**, respectively. The protrusion **774** prevents the first wall **770** from touching the second wall **771** when a force is applied to the delivery conduit **712** in a direction indicated by arrows **776**. The protrusion **775** prevents the first wall **772** from touching the second wall **773** when a force is applied to the delivery conduit **712** in a direction indicated by arrows **776**. In this manner, the protrusions **774**, **775** help prevent the lumens **766**, **768** from collapsing.

[0061] The second walls **771**, **773** include protrusions **777**, **778**, respectively. The protrusion **774** touches protrusion **777** when a force is applied to the delivery conduit **712** in a direction indicated by arrows **776** such that the portion of the first wall **770** and the second wall **771** that do not have protrusions **774** and **777** do not touch one another. Similarly, the protrusion **775** touches protrusion **778** when a force is applied to the delivery conduit **712** in a direction indicated by arrows **776** such that the portion of the first wall **772** and the second wall **773** that do not have protrusions **775** and **778** do not

touch one another. The lumens **766**, **768** may be prevented from collapsing in this manner.

[0062] Referring to FIG. 8, the delivery conduit **812** includes an angled divider **880**, which separates lumens **866**, **868** from one another. The angled divider **880** may alleviate pressure points on a foot, ankle, or leg when the foot, ankle, or leg presses against the delivery conduit **812** in a direction indicated by arrow **876**. In this example, the angled divider **880** may flatten when the foot, ankle, or leg presses against the delivery conduit **812** in a direction indicated by arrow **876**. The angled divider **880** may form an approximately 45 degree angle with the wall **873** of the lumen **868**, or any other lumen wall in the delivery conduit **812**.

[0063] Referring to FIGS. 9 and 10, an insole **908** is shown according to an illustrative embodiment. The insole **908** may be placed on a dorsal region **982** of the foot **905**, and, in particular, at the toe region of the foot **905**. In one example, the insole **908** may be composed of a foam, such as reticulated foam or a GranuFoam® material. The insole **908** may be coupled to the toe region of the foot **905** via the securing member **922**. Reduced pressure may be applied to the toe region by the insole **908** using reduced pressure that is delivered from a reduced-pressure source and delivered via the delivery conduit **912**.

[0064] The insole **908** includes protrusions **984**, which may be inserted between the toes of the foot **905**. The insole **908** may also include voids **918** through which reduced pressure may be applied to a region between the toes of the foot **905**. In another non-limiting example, each of the protrusions **984** may be placed on an individual toe of the foot **905**. The protrusions **984** may have any shape that facilitates the application of reduced pressure to the desired portion of the toe region of the foot **905**.

[0065] Although the present invention and its advantages have been disclosed in the context of certain illustrative, non-limiting embodiments, it should be understood that various changes, substitutions, permutations, and alterations can be made without departing from the scope of the invention as defined by the appended claims. It will be appreciated that any feature that is described in a connection to any one embodiment may also be applicable to any other embodiment.

What is claimed is:

1. An apparatus for applying reduced pressure to a tissue site on a foot, the apparatus comprising;
 - a) an insole having a plurality of protrusions extending from at least a portion of the insole to form a surface with grooves located between the protrusions;
 - a) a sealing layer covering the surface of the plurality of protrusions and forming flow channels with the grooves, a portion of the sealing layer adapted to have an opening to form a void configured to be in fluid communication with the tissue site, wherein at least a portion of the flow channels are fluidly coupled to the void for providing a reduced pressure to the void; and
 - a) a reduced-pressure interface fluidly coupled to the flow channels and adapted to receive reduced pressure from a reduced-pressure source for providing reduced-pressure to the void and the tissue site.
2. The apparatus of claim 1, wherein the opening in the sealing layer exposes at least a portion of two protrusions and the groove between the protrusions to form the void.

3. The apparatus of claim 1, wherein the at least one flow channel contains a tube transferring reduced pressure from the reduced-pressure interface to the void.

4. The apparatus of claim 1, further comprising:

a sealing member operable to substantially seal the void, the sealing member adapted to be disposed between the surface of the plurality of protrusions and the tissue site.

5. The apparatus of claim 1, wherein the at least one flow channel is at least partially formed by a groove on the insole.

6. The apparatus of claim 5, wherein the grooves forms a grid pattern.

7. The apparatus of claim 1, further comprising:

a foam manifold disposed in the void and adapted to further distribute reduced pressure to the tissue site.

8. The apparatus of claim 1, further comprising:

a delivery conduit fluidly coupled to the reduced-pressure interface and operable to transfer reduced pressure from the reduced pressure source to the reduced-pressure interface.

9. The apparatus of claim 8, wherein the delivery conduit comprises at least two lumens operable to transfer the reduced pressure from the reduced pressure source to the reduced-pressure interface, and wherein at least one wall of the at least two lumens has a protrusion operable to prevent the lumen from collapsing.

10. The apparatus of claim 1, further comprising:

a securing member operable to secure the insole adjacent the tissue site.

11. The apparatus of claim 1, wherein the void is adjacent the tissue site, and wherein the reduced pressure is applied to the tissue site via the void.

* * * * *