



US011866020B2

(12) **United States Patent**
Golov

(10) **Patent No.:** **US 11,866,020 B2**

(45) **Date of Patent:** ***Jan. 9, 2024**

(54) **DETECTING ROAD CONDITIONS BASED ON BRAKING EVENT DATA RECEIVED FROM VEHICLES**

G06V 10/82 (2022.01); **G06V 20/56** (2022.01); **G06V 20/58** (2022.01); **B60K 23/00** (2013.01); **B60T 7/12** (2013.01); **B60T 8/17** (2013.01); **B60W 2050/0075** (2013.01); **B60W 2556/10** (2020.02); **B60W 2556/65** (2020.02); **B62D 6/001** (2013.01); **G05D 2201/0213** (2013.01); **G06N 3/04** (2013.01)

(71) Applicant: **Micron Technology, Inc.**, Boise, ID (US)

(72) Inventor: **Gil Golov**, Backnang (DE)

(58) **Field of Classification Search**
CPC **G07C 5/008**; **H04W 4/40**; **H04W 64/003**; **H04W 64/006**; **G08G 1/0967**; **G08G 1/0967**; **G08G 1/09679**

(73) Assignee: **Lodestar Licensing Group LLC**, Evanston, IL (US)

See application file for complete search history.

(*) Notice: Subject to any disclaimer, the term of this patent is extended or adjusted under 35 U.S.C. 154(b) by 29 days.

(56) **References Cited**

This patent is subject to a terminal disclaimer.

U.S. PATENT DOCUMENTS

6,023,653 A 2/2000 Ichimura et al.
8,185,296 B2 5/2012 Yokoyama et al.
(Continued)

(21) Appl. No.: **17/493,742**

(22) Filed: **Oct. 4, 2021**

OTHER PUBLICATIONS

(65) **Prior Publication Data**
US 2022/0024469 A1 Jan. 27, 2022

Systems and Methods for Evaluating and Sharing Human Driving Style Information With Proximate Vehicles, U.S. Appl. No. 15/921,472, filed Mar. 14, 2018, Robert Bielby, Final Rejection Mailed, dated Oct. 13, 2021.

(Continued)

Related U.S. Application Data

(63) Continuation of application No. 16/010,060, filed on Jun. 15, 2018, now Pat. No. 11,161,518.

Primary Examiner — Anshul Sood

(74) *Attorney, Agent, or Firm* — Greenberg Traurig

(51) **Int. Cl.**
G05D 1/02 (2020.01)
G06N 3/04 (2023.01)
B60T 7/22 (2006.01)
B60W 50/00 (2006.01)
G06N 3/08 (2023.01)

(57) **ABSTRACT**

Data is received regarding vehicle braking events, each event occurring on one of a plurality of vehicles, and each event associated with a location. A determination is made that the braking events correspond to a pattern. Based on determining that the braking events correspond to the pattern, a first location is identified. In response to identifying the first location, at least one action is performed.

(Continued)

(52) **U.S. Cl.**
CPC **B60T 7/22** (2013.01); **B60W 50/0098** (2013.01); **G05D 1/0276** (2013.01); **G06N 3/08** (2013.01); **G06V 10/764** (2022.01);

22 Claims, 8 Drawing Sheets

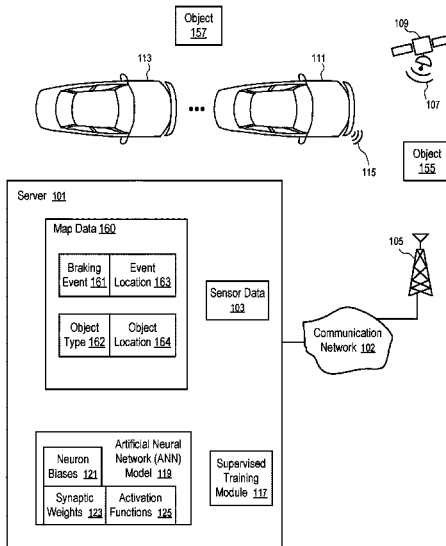

- (51) **Int. Cl.**
G06V 20/58 (2022.01)
G06V 10/764 (2022.01)
G06V 10/82 (2022.01)
G06V 20/56 (2022.01)
B60T 7/12 (2006.01)
B62D 6/00 (2006.01)
B60K 23/00 (2006.01)
B60T 8/17 (2006.01)

(56) **References Cited**
 U.S. PATENT DOCUMENTS

8,442,791 B2 5/2013 Stahlin
 8,543,320 B2 9/2013 Zheng et al.
 8,688,369 B2 4/2014 Denaro
 8,825,371 B2 9/2014 Prokhorov et al.
 9,043,127 B2 5/2015 Denaro
 9,062,977 B2 6/2015 Prokhorov et al.
 9,221,461 B2 12/2015 Ferguson et al.
 9,279,688 B2 3/2016 Denaro
 9,296,299 B2 3/2016 Ricci
 9,754,501 B2 9/2017 Stenneth
 9,786,172 B2 10/2017 Takahara et al.
 9,797,735 B2 10/2017 Denaro
 9,805,601 B1 10/2017 Fields et al.
 9,961,551 B2 5/2018 Scholl et al.
 10,031,523 B2 7/2018 Ricci et al.
 10,046,328 B2 8/2018 Nakayama et al.
 10,049,328 B2 8/2018 Jiang et al.
 10,068,477 B2 9/2018 Miller et al.
 10,099,697 B2 10/2018 Tatourian et al.
 10,139,831 B2 11/2018 Yan
 10,163,274 B1 12/2018 Brinkmann et al.
 10,179,586 B2 1/2019 Johnson
 10,215,571 B2 2/2019 Ghadiok et al.
 10,223,380 B2 3/2019 Giurgiu et al.
 10,257,270 B2 4/2019 Cohn et al.
 10,269,242 B2 4/2019 Ahmad et al.
 10,298,741 B2 5/2019 Goren et al.
 10,311,728 B2 6/2019 Stenneth et al.
 10,331,141 B2 6/2019 Grimm et al.
 10,345,110 B2 7/2019 Westover et al.
 10,460,394 B2 10/2019 Perl et al.
 10,493,994 B1 12/2019 Fields
 10,518,720 B2 12/2019 Haque
 10,529,231 B2 1/2020 Scofield
 10,543,853 B2 1/2020 Toyoda et al.
 10,648,818 B2 5/2020 Denaro
 10,755,111 B2 8/2020 Golov et al.
 10,997,429 B2 5/2021 Golov
 11,004,339 B2 5/2021 Oe et al.
 11,009,876 B2 5/2021 Bielby
 11,072,343 B2 7/2021 Emura et al.
 11,161,518 B2 11/2021 Golov
 11,441,916 B1 9/2022 Konrardy et al.
 2005/0232469 A1 10/2005 Schofield et al.
 2008/0189040 A1 8/2008 Nasu et al.
 2009/0234552 A1 9/2009 Takeda et al.
 2009/0265070 A1 10/2009 Okada et al.
 2010/0099353 A1 4/2010 Komori
 2011/0153532 A1 6/2011 Kuge et al.
 2011/0302214 A1 12/2011 Frye et al.
 2012/0109517 A1 5/2012 Watanabe
 2012/0296560 A1 11/2012 Zheng et al.
 2013/0054049 A1 2/2013 Uno
 2014/0067187 A1 3/2014 Ferguson et al.
 2014/0172290 A1 6/2014 Prokhorov et al.
 2014/0358414 A1 12/2014 Ibrahim et al.
 2015/0039365 A1 2/2015 Haque
 2015/0057838 A1 2/2015 Scholl et al.
 2016/0150070 A1 5/2016 Goren et al.
 2016/0176440 A1 6/2016 Witte et al.
 2016/0209841 A* 7/2016 Yamaoka B60W 60/0057
 2016/0229404 A1 8/2016 Byun
 2016/0280224 A1 9/2016 Tatourian et al.

2016/0351050 A1 12/2016 Takahara et al.
 2016/0363935 A1 12/2016 Shuster et al.
 2017/0015318 A1 1/2017 Scofield et al.
 2017/0039890 A1 2/2017 Truong et al.
 2017/0217433 A1 8/2017 Halder et al.
 2017/0232974 A1 8/2017 Nishida
 2017/0277716 A1 9/2017 Giurgiu et al.
 2017/0310747 A1 10/2017 Cohn et al.
 2017/0316691 A1 11/2017 Miller et al.
 2017/0323179 A1 11/2017 Vallespi-gonzalez
 2017/0372431 A1 12/2017 Perl et al.
 2018/0004223 A1 1/2018 Baldwin
 2018/0018869 A1 1/2018 Ahmad et al.
 2018/0038698 A1 2/2018 Denaro
 2018/0045519 A1 2/2018 Ghadiok et al.
 2018/0047285 A1 2/2018 Johnson
 2018/0050800 A1 2/2018 Boykin et al.
 2018/0093676 A1 4/2018 Emura et al.
 2018/0105186 A1 4/2018 Motomura et al.
 2018/0238702 A1 8/2018 Liebinger et al.
 2018/0259968 A1 9/2018 Frazzoli et al.
 2018/0293466 A1 10/2018 Viswanathan
 2018/0335785 A1 11/2018 Miller et al.
 2019/0009794 A1 1/2019 Toyoda et al.
 2019/0047584 A1 2/2019 Donnelly
 2019/0049257 A1 2/2019 Westover et al.
 2019/0049262 A1 2/2019 Grimm et al.
 2019/0051172 A1 2/2019 Stenneth et al.
 2019/0064843 A1 2/2019 Matsui et al.
 2019/0077413 A1 3/2019 Kondo et al.
 2019/0108752 A1 4/2019 Oe et al.
 2019/0147252 A1 5/2019 Sawada et al.
 2019/0168772 A1 6/2019 Emura et al.
 2019/0170519 A1 6/2019 Anwar et al.
 2019/0196481 A1 6/2019 Tay et al.
 2019/0236379 A1 8/2019 Golov et al.
 2019/0286133 A1 9/2019 Bielby
 2019/0287392 A1 9/2019 Bielby
 2019/0300017 A1 10/2019 Glaser et al.
 2019/0316913 A1 10/2019 Golov
 2019/0382004 A1 12/2019 Golov
 2019/0382029 A1 12/2019 Golov
 2020/0018604 A1 1/2020 Zhang et al.
 2020/0023839 A1 1/2020 Yan
 2020/0039508 A1 2/2020 Onishi
 2020/0135021 A1 4/2020 Akachi
 2020/0202560 A1 6/2020 Viswanathan
 2020/0217667 A1 7/2020 Kim et al.
 2020/0263996 A1 8/2020 Gokhale et al.
 2020/0387722 A1 12/2020 Golov et al.
 2021/0070286 A1 3/2021 Green et al.
 2021/0216790 A1 7/2021 Golov
 2021/0271243 A1 9/2021 Bielby
 2022/0176989 A1 6/2022 Hwang et al.
 2023/0041045 A1 2/2023 Golov
 2023/0045250 A1 2/2023 Golov

OTHER PUBLICATIONS

Systems and Methods for Evaluating and Sharing Autonomous Vehicle Driving Style Information With Proximate Vehicles, U.S. Appl. No. 15/921,491, filed Mar. 14, 2018, Robert Bielby, Patented Case, Jul. 31, 2020.
 Systems and Methods for Evaluating and Sharing Autonomous Vehicle Driving Style Information With Proximate Vehicles, U.S. Appl. No. 17/321,349, filed May 14, 2021, Robert Bielby, Docketed New Case—Ready for Examination, Aug. 23, 2021.
 Determining Autonomous Vehicle Status Based on Mapping of Crowdsourced Object Data, U.S. Appl. No. 15/951,087, filed Apr. 11, 2018, Gil Golov, Patented Case, Oct. 15, 2020.
 Determining Autonomous Vehicle Status Based on Mapping of Crowd Sourced Object Data, U.S. Appl. No. 17/216,351, filed Mar. 29, 2021, Gil Golov, Docketed New Case—Ready for Examination, Aug. 22, 2021.
 Detecting Road Conditions Based on Braking Event Data Received From Vehicles, U.S. Appl. No. 16/010,060, filed Jun. 15, 2018, Gil Golov, Patented Case, Jan. 28, 2021.

(56)

References Cited

OTHER PUBLICATIONS

Identifying Suspicious Entities Using Autonomous Vehicles, U.S. Appl. No. 15/882,168, filed Jan. 29, 2018, Gil Golov et al., Patented Case, Aug. 5, 2020.

Identifying Suspicious Entities Using Autonomous Vehicles, U.S. Appl. No. 17/001,546, filed Aug. 24, 2020, Gil Golov et al., Docketed New Case—Ready for Examination, Sep. 24, 2020.

International Search Report and Written Opinion, PCT/US2019/025112, dated Jul. 19, 2019.

Zhang, Xiaoyu, “The research of traffic information collection system based on crowdsourcing and related privacy issues”, master’s thesis, May 28, 2016, Jilin University, Changchun, China.

* cited by examiner

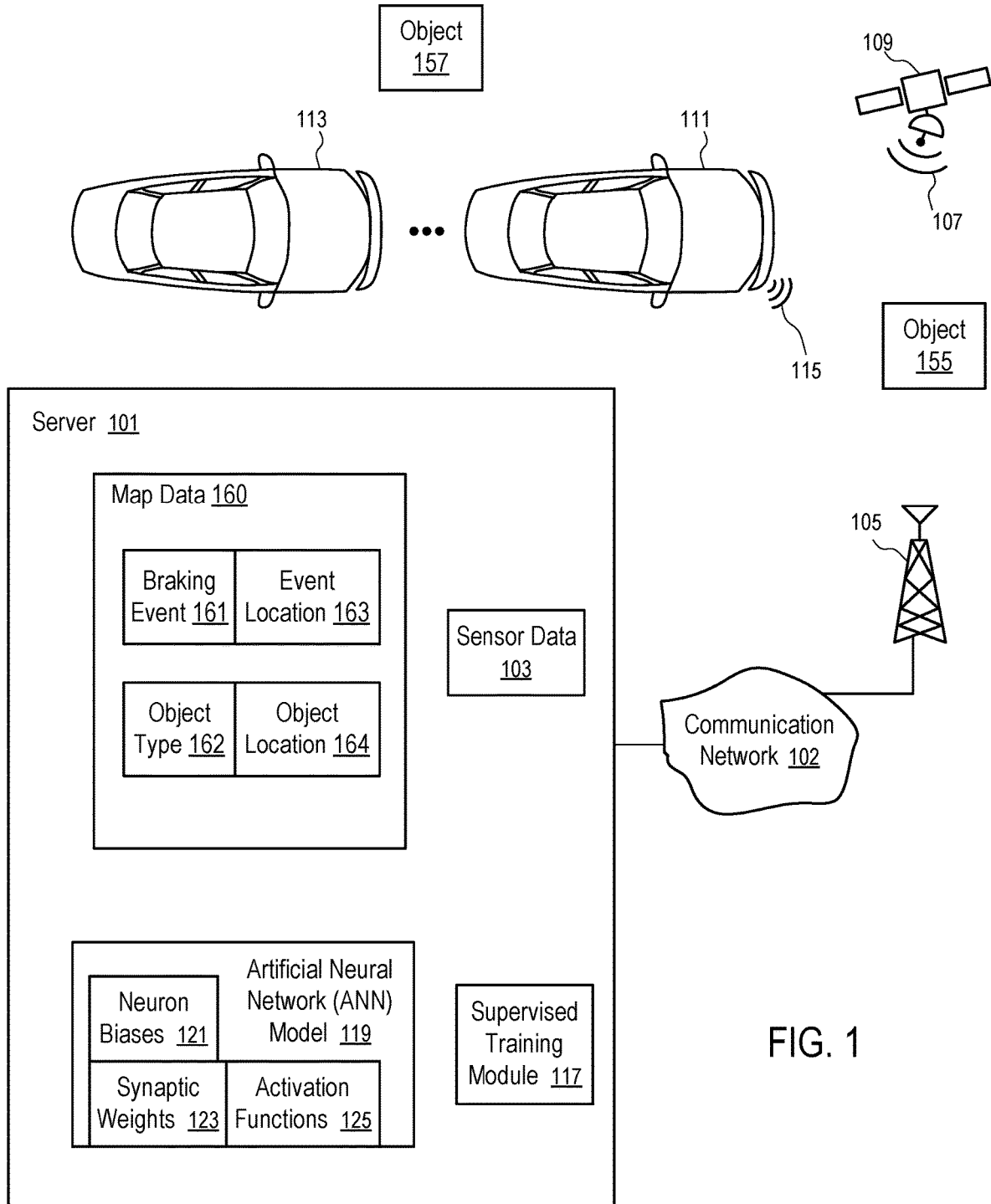

FIG. 1

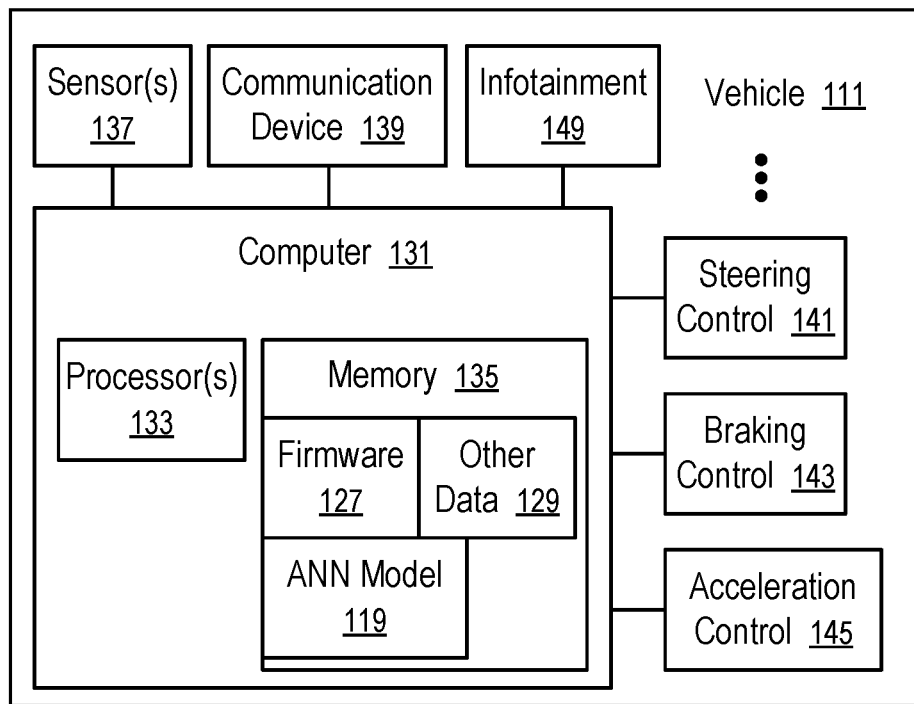

FIG. 2

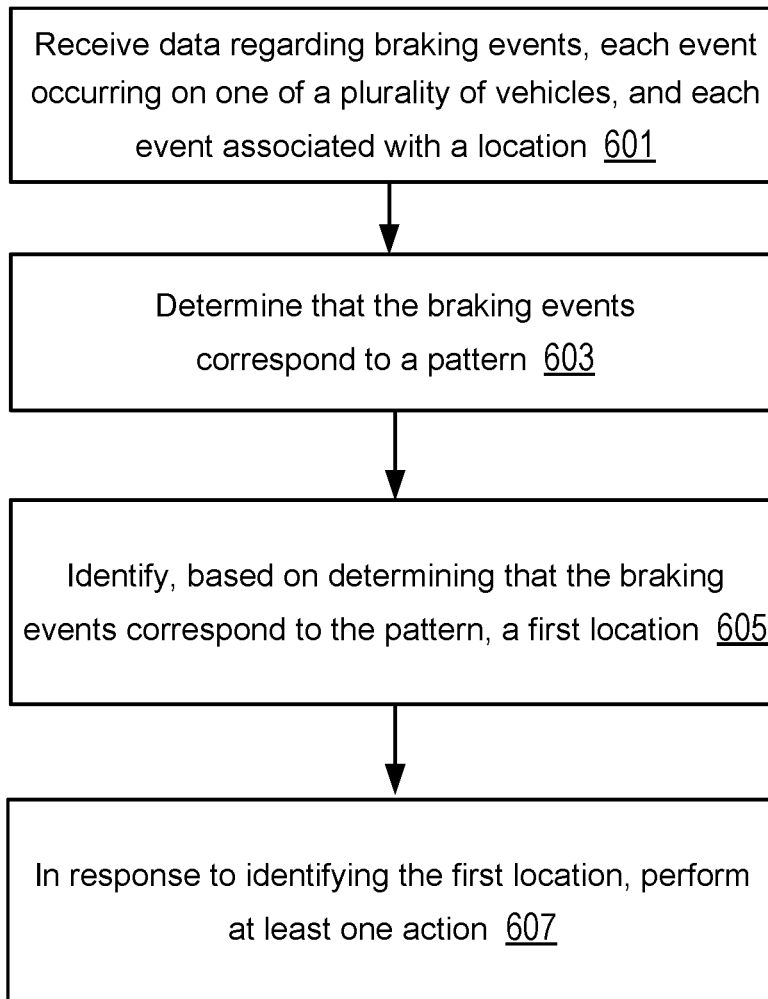

FIG. 3

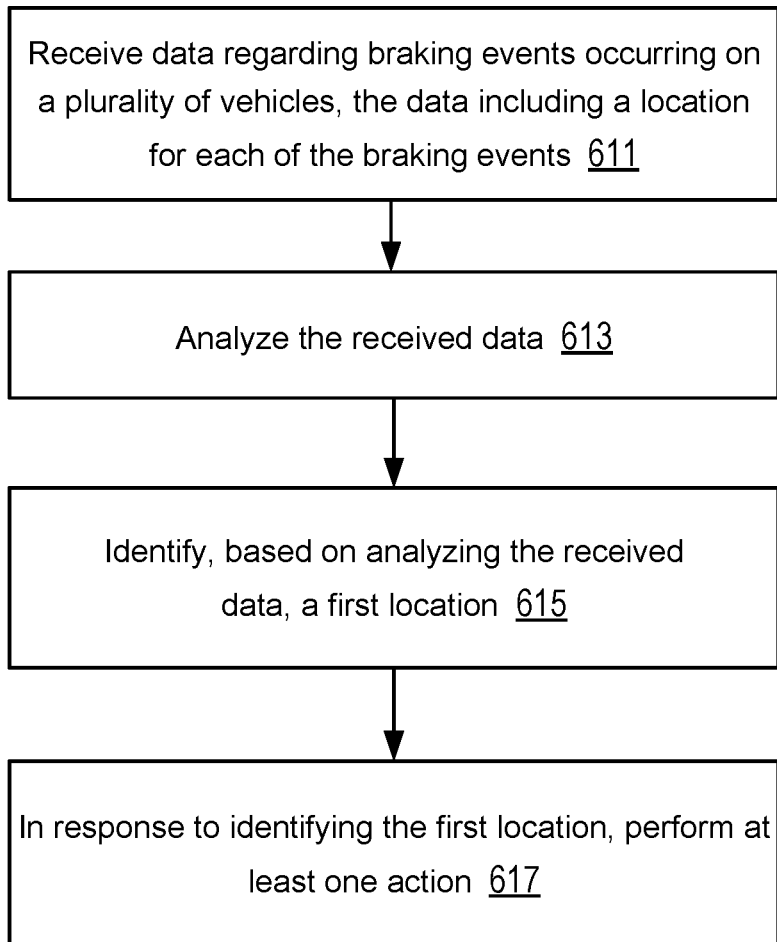

FIG. 4

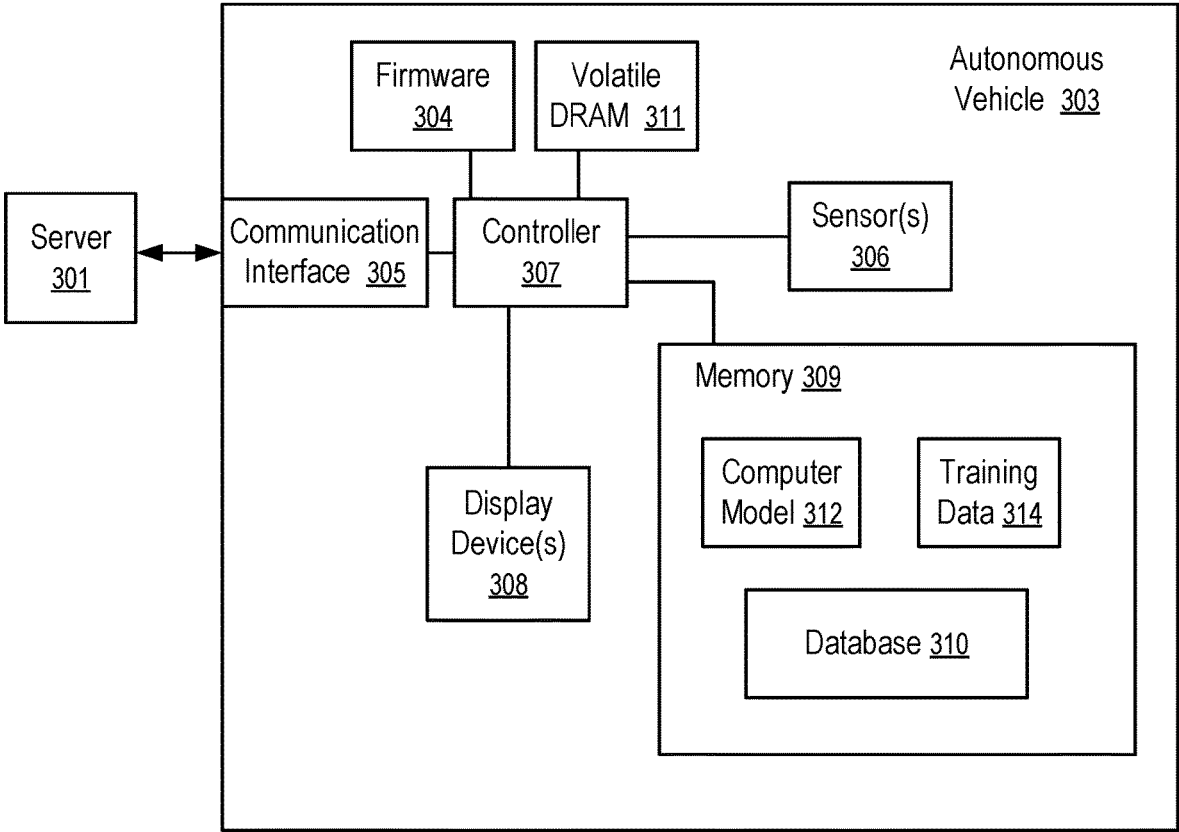

FIG. 5

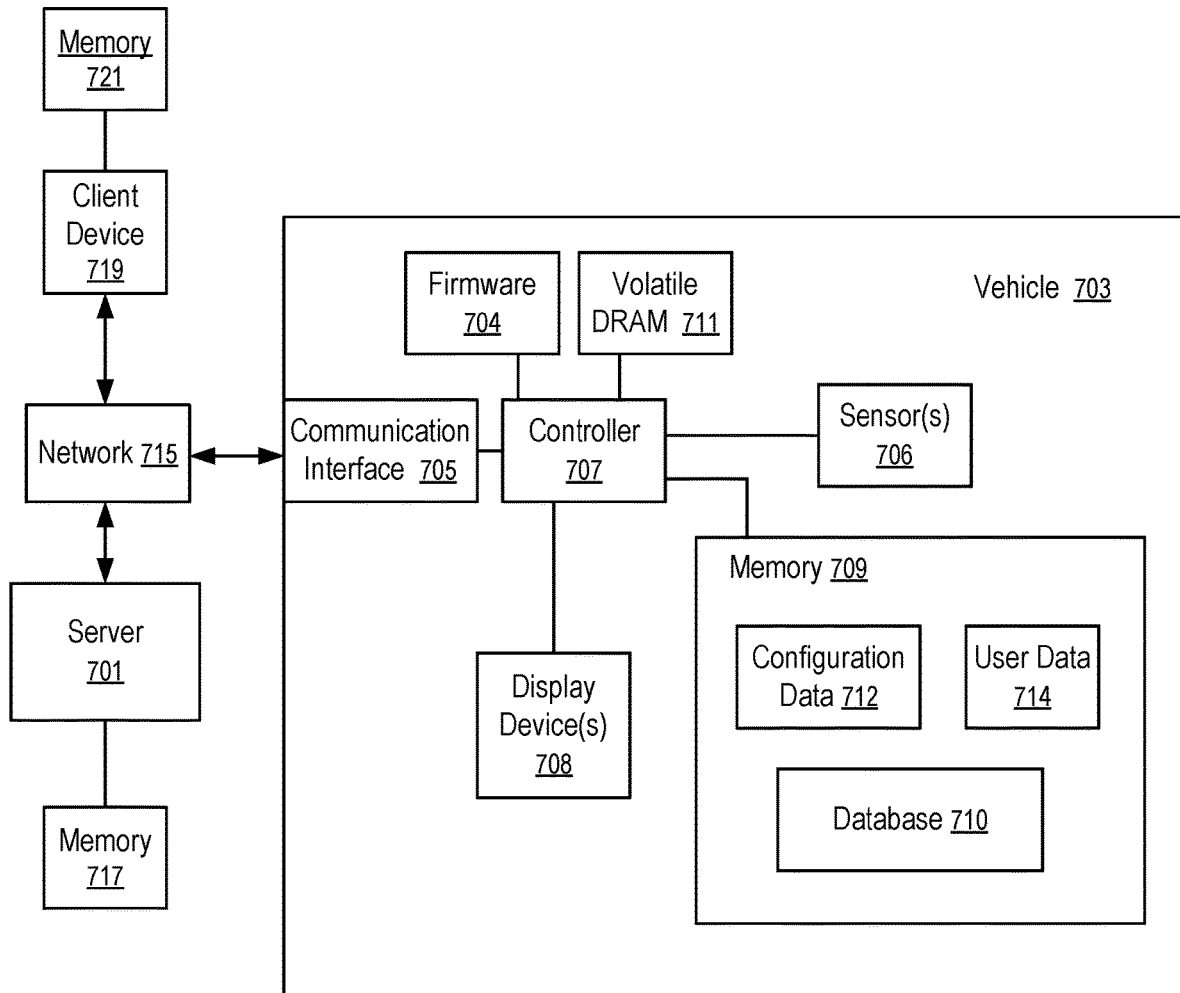

FIG. 6

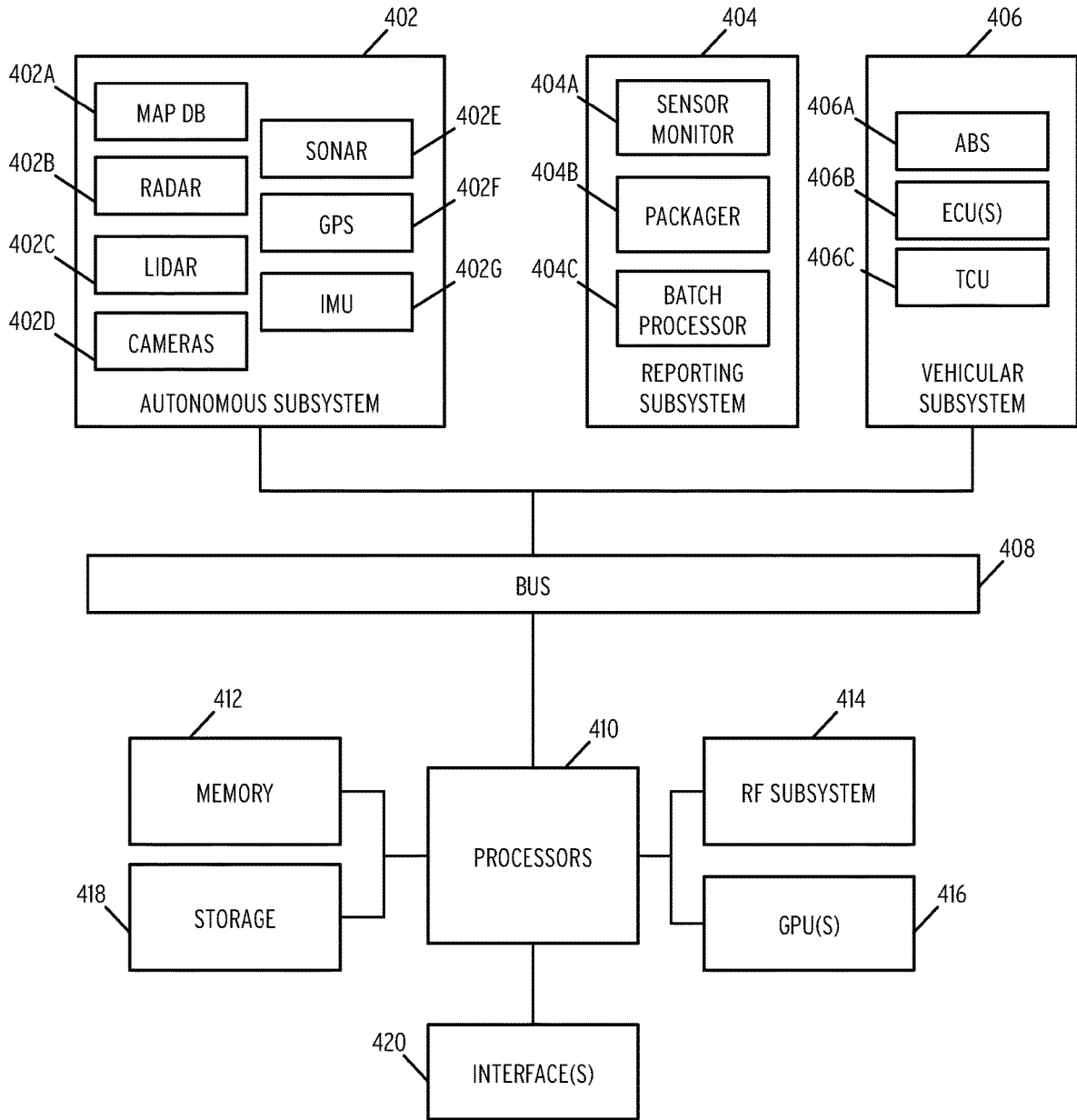

FIG. 7

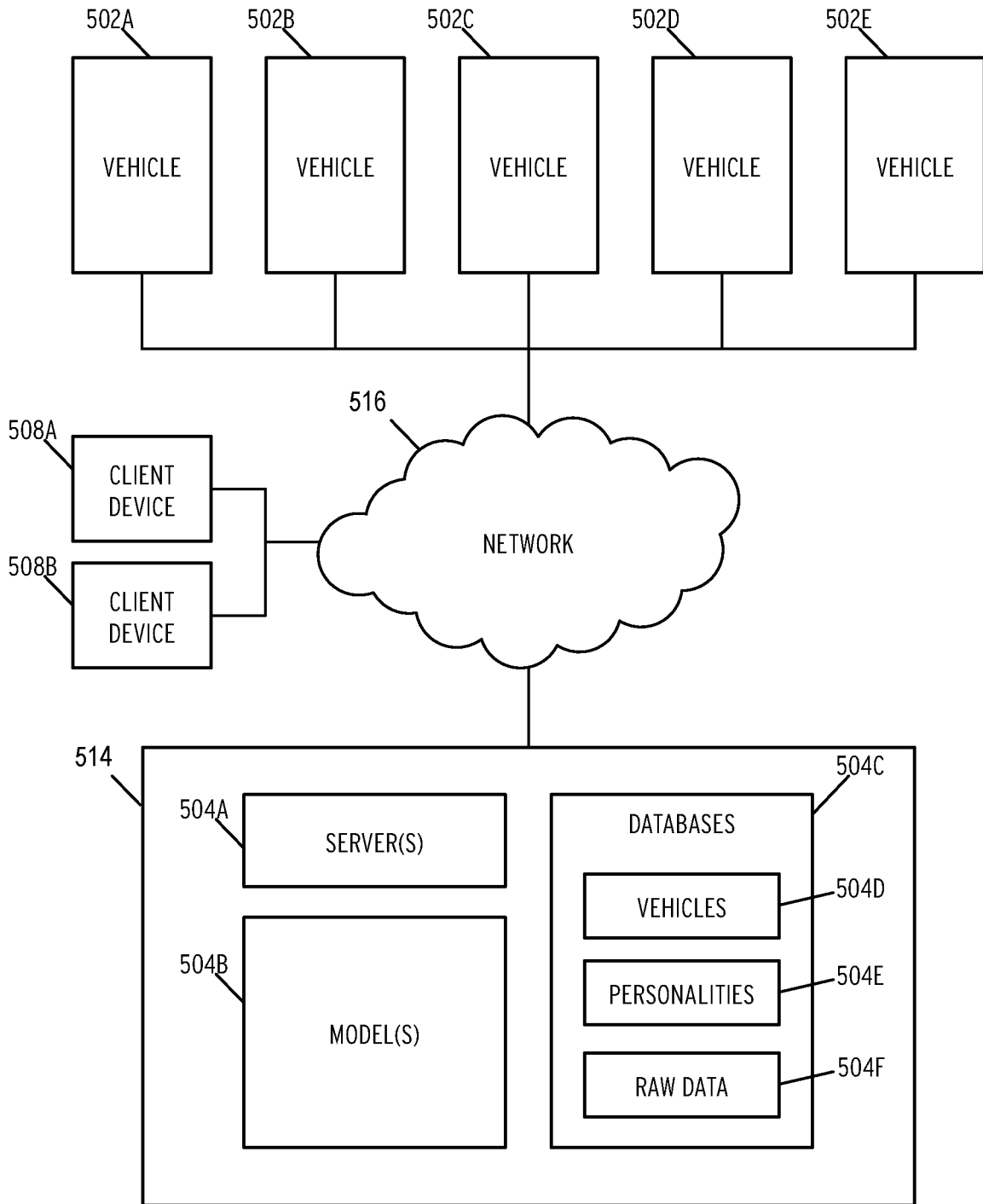

FIG. 8

DETECTING ROAD CONDITIONS BASED ON BRAKING EVENT DATA RECEIVED FROM VEHICLES

RELATED APPLICATIONS

The present application is a continuation application of U.S. patent application Ser. No. 16/010,060 filed Jun. 15, 2018, the entire disclosure of which application is hereby incorporated herein by reference.

This application is related to U.S. Pat. No. 10,997,429 issued on May 4, 2021, entitled "Determining Autonomous Vehicle Status Based on Mapping of Crowdsourced Object Data," by Gil Golov, the entire contents of which application is incorporated by reference as if fully set forth herein.

This application is also related to U.S. Pat. No. 10,894,545 issued on Jan. 19, 2021, entitled "Configuration of a Vehicle Based on Collected User Data," by Robert Richard Noel Bielby, the entire contents of which application is incorporated by reference as if fully set forth herein.

FIELD OF THE TECHNOLOGY

At least some embodiments disclosed herein relate to monitoring operating events for vehicles in general, and more particularly, but not limited to, monitoring data regarding braking events occurring on vehicles.

BACKGROUND

A user of a vehicle can be a driver in the case of a manually-driven vehicle. In other cases, such as for an autonomous vehicle, the user of the vehicle typically performs fewer control actions than a "driver" as regards the operation of the vehicle. For example, in some cases, the user may simply select a destination to which the vehicle travels, but without performing any directional or other control of the immediate movement of the vehicle on the roadway.

Recent developments in the technological area of autonomous driving allow a computing system to operate, at least under some conditions, control elements of a vehicle without the assistance from a user of the vehicle. For example, sensors (e.g., cameras and radars) can be installed on a vehicle to detect the conditions of the surroundings of the vehicle on a roadway. One function of these sensors is to detect objects that are encountered during travel of the vehicle.

Autonomous vehicles use a variety of sensors and artificial intelligence algorithms to detect these objects and to analyze the changing environment around the vehicle during travel. Objects that are encountered may include, for example, traffic lights, road signs, road lanes, etc. Failing to detect certain of these objects could cause an unexpected or undesired behavior of the vehicle, and in some cases could expose passengers of the vehicle and/or others outside of the vehicle (e.g., in the immediate area surrounding the vehicle) to danger.

In some cases, an object may be positioned in a way that creates an unsafe driving condition (e.g., a deep pothole in the center of a road). Failure by a driver or an autonomous vehicle navigation system to detect the unsafe condition may create a physical danger of injury to the driver and/or other passengers of a vehicle (e.g., a vehicle that suddenly encounters a deep pothole or other unsafe road condition without warning).

During normal operation of a vehicle, the various sensors are used to operate the vehicle. For example, a computing system installed on the vehicle analyzes the sensor inputs to identify the conditions and generate control signals or commands for the autonomous adjustments of the direction and/or speed of the vehicle, without any input from a human operator of the vehicle. Autonomous driving and/or advanced driver assistance system (ADAS) typically involves an artificial neural network (ANN) for the identification of events and/or objects that are captured in sensor inputs.

In general, an artificial neural network (ANN) uses a network of neurons to process inputs to the network and to generate outputs from the network. Each neuron m in the network receives a set of inputs p_k , where $k=1, 2, \dots, n$. In general, some of the inputs to a neuron may be the outputs of certain neurons in the network; and some of the inputs to a neuron may be the inputs to the network as a whole. The input/output relations among the neurons in the network represent the neuron connectivity in the network.

Each neuron m has a bias b_m , an activation function f_m , and a set of synaptic weights w_{mk} for its inputs p_k respectively, where $k=1, 2, \dots, n$. The activation function may be in the form of a step function, a linear function, a log-sigmoid function, etc. Different neurons in the network may have different activation functions.

Each neuron m generates a weighted sum s_m of its inputs and its bias, where $s_m = b_m + w_{m1} \times p_1 + w_{m2} \times p_2 + \dots + w_{mn} \times p_n$. The output a_m of the neuron m is the activation function of the weighted sum, where $a_m = f_m(s_m)$.

The relations between the input(s) and the output(s) of an ANN in general are defined by an ANN model that includes the data representing the connectivity of the neurons in the network, as well as the bias b_m , activation function f_m , and synaptic weights w_{mk} of each neuron m . Using a given ANN model, a computing device computes the output(s) of the network from a given set of inputs to the network.

For example, the inputs to an ANN network may be generated based on camera inputs; and the outputs from the ANN network may be the identification of an item, such as an event or an object.

For example, U.S. Pat. App. Pub. No. 2017/0293808, entitled "Vision-Based Rain Detection using Deep Learning", discloses a method of using a camera installed on a vehicle to determine, via an ANN model, whether the vehicle is in rain or no rain weather.

For example, U.S. Pat. App. Pub. No. 2017/0242436, entitled "Road Construction Detection Systems and Methods", discloses a method of detecting road construction using an ANN model.

For example, U.S. Pat. Nos. 9,672,734 and 9,245,188 discuss techniques for lane detection for human drivers and/or autonomous vehicle driving systems.

In general, an ANN may be trained using a supervised method where the synaptic weights are adjusted to minimize or reduce the error between known outputs resulted from respective inputs and computed outputs generated from applying the inputs to the ANN. Examples of supervised learning/training methods include reinforcement learning, and learning with error correction.

Alternatively or in combination, an ANN may be trained using an unsupervised method where the exact outputs resulted from a given set of inputs is not known a priori before the completion of the training. The ANN can be trained to classify an item into a plurality of categories, or data points into clusters.

Multiple training algorithms are typically employed for a sophisticated machine learning/training paradigm.

The disclosures of the above discussed patent documents are hereby incorporated herein by reference.

BRIEF DESCRIPTION OF THE DRAWINGS

The embodiments are illustrated by way of example and not limitation in the figures of the accompanying drawings in which like references indicate similar elements.

FIG. 1 illustrates a system to receive data regarding braking events occurring on a plurality of vehicles, according to one embodiment.

FIG. 2 shows an example of a vehicle configured using an Artificial Neural Network (ANN) model, according to one embodiment.

FIG. 3 shows a method to identify a location based on determining that braking events correspond to a pattern, according to one embodiment.

FIG. 4 shows a method to identify a location based on analysis of data regarding braking events for a plurality of vehicles, according to one embodiment.

FIG. 5 shows an autonomous vehicle controlled and/or configured in response to determining identifying a location associated with braking events, according to one embodiment.

FIG. 6 shows a vehicle controlled and/or configured via a communication interface using a cloud service, according to one embodiment.

FIG. 7 is a block diagram of an autonomous vehicle including one or more various components and/or subsystems, each of which can be updated in various embodiments to configure the vehicle and/or perform other actions associated with the vehicle.

FIG. 8 is a block diagram of a centralized autonomous vehicle operations system, according to various embodiments.

DETAILED DESCRIPTION

Currently, the technology supporting autonomous and other vehicles continues to improve. Improvements in digital camera technology, light detection and ranging (LIDAR), and other technologies have enabled vehicles to navigate roadways independent of drivers or with limited assistance from drivers. In some environments, such as factories, autonomous vehicles operate without any human intervention whatsoever.

While autonomous technology is primarily focused on controlling the movement of vehicles in a traditional sense, little emphasis has been placed on alternative applications that may be implemented on top of these autonomous systems. Indeed, application-level systems generally tend to reinforce existing uses of autonomous systems. For example, experimental uses of autonomous technology have been utilized to perform functions such as returning vehicles to a known location after delivering a passenger or performing refueling of vehicles while not utilized by passengers.

However, these approaches fail to fully utilize the hardware and processing power being implemented in autonomous vehicles, or in other vehicles utilizing automated driver assistance systems. Thus, there currently exists a need in the state of the art of autonomous and other vehicles to provide additional services leveraging the existing hardware installed within such vehicles.

In particular, there is a need to solve the technical problem of detecting unsafe road conditions that may be encountered

by an autonomous or other vehicle during its operation. In particular, this technical problem includes the need to determine whether navigation and/or other control of the vehicle should be performed to avoid the unsafe condition. In many cases, this detection of unsafe road conditions needs to be determined in real-time.

At least some embodiments disclosed herein relate to monitoring data regarding braking events occurring on vehicles. The data is received from each of the vehicles (e.g., received by a server). Analysis of the braking event data is used to identify unsafe locations, and in response to perform control actions for a vehicle currently being operated (e.g., controlling navigation of a current vehicle based on analysis of the braking event data). These embodiments provide a technological solution to the above technical problem by analyzing data regarding braking events received from other vehicles to identify the unsafe location and cause a control response for a current vehicle. Based on this analysis, an unsafe location on a road (e.g., corresponding to an unsafe road condition) is identified and/or determined. In response, a currently-operating vehicle (sometimes referred to herein as simply "current" vehicle) is, for example, alerted and/or controlled in order to avoid the unsafe road condition. The current vehicle is, for example, a manually-driven vehicle or an autonomous vehicle (e.g., a car, truck, aircraft, drone, watercraft, etc.). In one example, an unsafe road condition may include alien objects that are unsafely positioned on a road. For example, a tree may have unexpectedly fallen on a road due to a recent storm, and the tree is blocking safe travel on the road.

In one embodiment, a cloud service (sometimes referred to as simply the cloud) is used to detect unsafe driving road conditions. For example, when a driver performs an emergency braking, or the automatic emergency braking system of a vehicle is activated, the location of that braking event is transmitted to, for example, a server or other computing device in the cloud service. The location itself may be determined, for example, based on location data (e.g., geographic coordinates) provided from the vehicle itself (e.g., by a GPS location system) and/or location data otherwise associated with or known about the vehicle. The cloud searches for a pattern of emergency braking at the same location (within a tolerance such as, for example, a predetermined distance), which have been reported by numerous vehicles (e.g., other vehicles traveling the same road prior to the current vehicle). This pattern may be used to make a determination that driving is unsafe in that particular location.

In one embodiment, braking event data received from vehicles is analyzed to determine that the braking events correspond to a pattern. For example, pattern recognition can be used on the received data. In one case, machine learning is used to recognize patterns or regularities in data. In some cases, a pattern recognition system can be trained from labeled training data (e.g., supervised learning). In other cases, when no labeled data is available, other algorithms can be used to identify previously unknown patterns (e.g., unsupervised learning).

In one embodiment, a braking event is identified based on a measurement of a brake pedal in a vehicle. For example, a braking event may be identified based on a foot pressure or extent of movement as compared to a predetermined threshold. In another embodiment, a braking event is identified based on a rate of deceleration of the vehicle. For example, if a rate of deceleration exceeds a predetermined threshold, then a braking event is identified. In another

example, the rate of deceleration is observed over a predetermined time period (e.g., the rate is averaged over the time period).

In one embodiment, braking event data is analyzed to identify a pattern in which two or more locations of vehicles experiencing a braking event fall within a predetermined distance of another location (e.g., associated with collected or received data), or a predetermined region (e.g., a circular or other area of a predetermined radius or other dimension that encloses locations of braking events).

In one embodiment, identifying an unsafe location requires that a number of braking events within a time period exceed a predetermined number or threshold. For example, the identification can require that three or more braking events occur in a given day.

In one embodiment, in response to identifying an unsafe location, at least one action is performed. For example, a communication can be sent to a current vehicle that identifies the location. In another example, the location can be transmitted to another computing device that is used to control traffic flows, vehicle navigation, etc. In another example, this information can be used, for example, to improve road conditions, traffic sign and traffic lights infrastructure around the unsafe location (e.g., this may improve driving safety).

In another embodiment, braking event data is received by a server (e.g., a server of a cloud service) and stored as a map of locations of the braking events. Data for each braking event is, for example, received from other vehicles that have previously experienced a braking event (e.g., the hardware of these other vehicles is used to collect sensor and other data regarding the braking event that occurred during travel). For example, these other vehicles can be vehicles that have previously traveled over the same road that a current vehicle is presently traveling on. By storing data regarding the braking events (e.g., storing in a map), the current vehicle can be controlled during operation so as to avoid any unsafe locations that are determined from the braking event data.

In one embodiment, additional data from other vehicles can be received and/or stored that relates to objects detected by the other vehicles. For example, a fallen tree may be detected within a predetermined time of the occurrence of a braking event. For example, the map above can store data regarding the stop sign detected by one or more prior vehicles. The map includes a location of the stop sign along with data regarding an associated braking event.

Data received from a current vehicle traveling at or near this same location is compared to data stored in the map. In one example, based on comparing the data received from the current vehicle to the stored map data, navigation or another operating status of the current vehicle is controlled or changed (e.g., an updated configuration is performed). For example, it may be determined that the current vehicle should begin braking at least a predetermined distance or time prior to reaching a location that has been identified as unsafe.

In one embodiment, a cloud service receives braking event data from numerous vehicles. The braking event data is used to create a map of unsafe locations. These unsafe locations are identified based on analysis of the braking event data. The map data can be provided, for example, as an online service to other computing devices associated with vehicle operation. For example, the map data can be used by a server that controls operation of one or more autonomous vehicles. In another example, the service can transmit data to one or more vehicles that is used to control at least one action performed by the vehicle.

As mentioned above, in addition to braking event data, vehicles may send other data. For example, data regarding physical objects detected by vehicles can be sent to a server in a cloud. A map is stored that includes locations for each of these detected objects (e.g., along with braking event data). For example, the map can include data collected by the prior vehicles. For example, locations of physical objects can be based on data received from the prior vehicles.

In one embodiment, objects detected by prior vehicles (e.g., passive objects, such as traffic signs, traffic lights, etc.) are transmitted to the cloud service. The cloud service creates a dynamic map containing the type of object detected and its location (e.g., the map stores data that a stop sign is located at a position x, y). The cloud service stores the map (e.g. in a database or other data repository). Braking event data is also stored in the map (e.g., braking event locations associated with objects within a predetermined distance of the braking event location).

In one embodiment, in response identifying an unsafe location (e.g., as determined based on pattern recognition using braking event data), a server can perform one or more actions. For example, the server can send a communication to the current vehicle. In one case, the communication can cause the current vehicle to take corrective actions, such as terminating an autonomous navigation mode, braking, or changing course.

In one embodiment, in response to receiving a communication from a server, a current vehicle can switch off its autonomous driving mode, use a backup system, and/or activate a braking system to stop the vehicle.

In another embodiment, the cloud service can send a communication to a server or other computing device that monitors an operating status for other vehicles (e.g., a central monitoring service). For example, the cloud service can send a communication to a server operated by governmental authorities. The communication can, for example, identify that a road has an unsafe condition (e.g., at an identified location). In some cases, in response to a determination that the current vehicle has been in an accident associated with an identified unsafe location, the communication can be sent to the server or other computing device. In such a case, one or more indications provided to the server or other computing device can include data obtained from the current or another vehicle associated with a braking event at the accident location (e.g., data stored by the vehicle regarding operating functions and/or state of the vehicle prior to the accident, such as within a predetermined time period prior to the accident).

In one embodiment, the determination whether a vehicle has experienced a braking event and/or been involved in an accident can be based on data from one or more sensors of the vehicle. For example, data from an accelerometer of the vehicle can indicate a rapid deceleration of the vehicle (e.g., deceleration exceeding a threshold). In another case, data can indicate that an emergency system of the vehicle has been activated, such as for example, an airbag, an emergency braking system, etc. In some embodiments, any one and/or a combination of the foregoing events can be deemed to be a braking event for which location data is transmitted to a server.

In one embodiment, a route (e.g., data for the current location of the vehicle) taken by a vehicle being monitored is sent periodically to a cloud service. One or more sensors on the current vehicle are used to obtain data regarding braking events and/or objects in the environment of the vehicle as it travels along the route. Data from the sensors and/or data generated based on analysis of sensor data

and/or other data can be, for example, transmitted to the cloud service wirelessly (e.g., using a 3G, 4G, or 5G network or other radio-based communication system).

In one embodiment, in response to identifying an unsafe road location determined based on braking event data, one or more actions of a vehicle are configured. For example, an over-the-air firmware update can be sent to the vehicle for updating firmware of a computing device of the vehicle (e.g., this update causes the vehicle to avoid identified unsafe locations and/or objects at such locations). In one example, the firmware updates a navigation system of the vehicle. The updated configuration is based at least in part on analysis of data that is collected from other vehicles.

In various other embodiments, the configuration of one or more actions performed by a vehicle in response to identifying a location may include, for example, actions related to operation of the vehicle itself and/or operation of other system components mounted in the vehicle and/or otherwise attached to the vehicle. For example, the actions may include actions implemented via controls of an infotainment system, a window status, a seat position, and/or driving style of the vehicle.

In some embodiments, the analysis of braking event and/or sensor data collected by the current or other prior vehicles includes providing the data as an input to a machine learning model. The current vehicle is controlled by performing one or more actions that are based on an output from the machine learning model.

In one example, a machine learning model is trained and/or otherwise used to configure a vehicle (e.g., tailor actions of the vehicle). For example, the machine learning model may be based on pattern matching in which prior patterns of sensor inputs or other data is correlated with desired characteristics or configuration(s) for operation of the vehicle.

In one embodiment, data received from the current vehicle may include sensor data collected by the vehicle during its real world services (e.g., when the user is a driver or a passenger). In one embodiment, the data is transmitted from the vehicles to a centralized server (e.g., of a cloud service), which performs machine learning/training, using a supervised method and the received sensor data and/or other data, to generate an updated ANN model that can be subsequently loaded into the vehicle to replace its previously-installed ANN model. The model is used to configure the operation of the vehicle.

In some embodiments, the driver can take over certain operations from the vehicle in response to the vehicle receiving a communication that an unsafe location has been identified. One or more cameras of the vehicle, for example, can be used to collect image data that assists in implementing this action. In one example, the vehicle is configured in real-time to respond to the received braking event and/or object data.

FIG. 1 illustrates a system to receive data regarding braking events occurring on a plurality of vehicles, according to one embodiment. The system uses an Artificial Neural Network (ANN) model in some embodiments. The system of FIG. 1 includes a centralized server **101** in communication with a set of vehicles **111**, . . . , **113** via a communication network **102**.

In one embodiment, data regarding braking events occurring on vehicles (e.g., other or prior vehicle **113**) is received by server **101** via communication network **102**. The received data includes a location for each of the braking events. For example, the received data can include an event location **163** for each braking event **161**. Braking event **161** can include

data such as, for example, an identifier, a type of braking event, etc. The received braking event data can be stored as part of map data **160**.

In some embodiments, additional data is received by server **101** from the vehicles. This can include, for example, data regarding detected objects such as object type **162** and object location **164**. This additional data can be stored as part of map data **160**. Also, additional data such as sensor data **103** can be received from the vehicles.

The braking event data received from the vehicles by server **101** is analyzed. For example, this analysis can include pattern recognition or other data analysis (e.g., determining a correlation of braking event data to other data) to determine that the braking events correspond to a pattern. For example, event location data **163** can be analyzed to detect a pattern. In one embodiment, this pattern detection can be based at least in part on an output from artificial neural network model **119**.

Based on analysis of the received braking event data, a location is identified (e.g., an unsafe road obstacle). For example, server **101** may determine that a set of braking events corresponds to a pattern and a corresponding location is identified based on this determination. In one example, a location can be determined as being unsafe based on numerous emergency braking activations on vehicles at that location or within a predetermined distance of the identified location.

In response to identifying the location, at least one action is performed. For example, server **101** can transmit a communication to current vehicle **111** that causes the vehicle to change a navigation path and/or activate a braking system when within a predetermined distance of the identified unsafe location.

In some embodiments, in addition to sending data regarding braking events, vehicle **113** and/or other prior vehicles send data regarding objects detected during travel (e.g. vehicle **113** can be traveling prior to current vehicle **111**, which arrives later at the same location where an object has been detected by vehicle **113**). These objects can include, for example, object **155** and object **157**. Sensors of vehicle **113** and the other prior vehicles collect and/or generate data regarding the objects that have been detected. Data regarding detected objects can be analyzed in conjunction with braking event data in order to identify a location that prompts an action.

Data regarding the detected objects is sent, via communications network **102**, to a computing device such as server **101** (e.g., which may be part of a cloud service). Server **101** receives the object data from vehicle **113** and the other prior vehicles. Server **101** stores a map (e.g., including map data **160**), which may include a number of records for each object. In one example, map data **160** includes object type **162** and object location **164** for each object. Map data **160** also may include braking event data **161** and corresponding event locations **163**, as mentioned above.

Subsequent to receiving the data regarding detected objects from the prior vehicles, a current vehicle **111** also may transmit data regarding new objects that are being detected during travel. For example, object **155** can be a new object from the perspective of vehicle **111**.

Server **101** receives data regarding object **155** from vehicle **111**. In some embodiments, server **101** may determine, based on comparing the data regarding object **155** that is received from vehicle **111** to data regarding object **155** that is stored in map data **160**, how vehicle **111** should respond to an unsafe location that has been identified.

In some cases, vehicle **111** sends its current location to server **101**. The location of vehicle **111** is compared to object location **164** for object **155**. Server **101** determines a response that vehicle **111** should perform associated with object **155**.

In one embodiment, in response to identifying a location, server **101** performs one or more actions. For example, server **101** can transmit a communication to vehicle **111** that causes a termination of an autonomous driving mode.

In one embodiment, sensor data **103** can be collected in addition to map data **160**. Sensor data **103** can be, for example, provided by the current vehicle **111** and/or prior vehicles **113** (e.g., sensor data **103** may be for data other than object data, such as temperature, acceleration, audio, etc.). Sensor data **103** can be used in combination with map data **160** and/or other new data received from current vehicle **111** to perform an analysis of received data (including received braking event data). In some cases, some or all of the foregoing data can be used to train artificial neural network model **119**. Additionally, in some cases, an output from artificial neural network model **119** can be used as part of making a determination of an unsafe location.

In some embodiments, at least a portion of map data **160** can be transmitted to vehicle **111** and a determination or control action (e.g., navigation path change) regarding an operating status of vehicle **111** can be locally determined by a computing device mounted on or within vehicle **111**. In some embodiments, artificial neural network model **119** itself and/or associated data can be transmitted to and implemented on vehicle **111** and/or other vehicles. An output from artificial neural network model **119** can be used to determine actions performed in response to identifying an unsafe location based on braking event data (e.g., an identification received from server **101** by vehicle **111**).

In one embodiment, data from vehicle **111** (or from vehicle **113**) can be collected by sensors located in the vehicle. The collected data is analyzed, for example, using a computer model such as an artificial neural network (ANN) model. In one embodiment, the collected data is provided as an input to the ANN model. For example, the ANN model can be executed on server **101** and/or vehicle **111**. The vehicle **111** is controlled based on at least one output from the ANN model. For example, this control includes performing one or more actions based on the output. These actions can include, for example, control of steering, braking, acceleration, and/or control of other systems of vehicle **111** such as an infotainment system and/or communication device.

In one embodiment, the server **101** includes a supervised training module **117** to train, generate, and update ANN model **119** that includes neuron biases **121**, synaptic weights **123**, and activation functions **125** of neurons in a network used for processing braking event data, and/or other collected data regarding a vehicle and/or sensor data generated in the vehicles **111**, . . . , **113**.

In one embodiment, once the ANN model **119** is trained and implemented (e.g., for autonomous driving and/or an advanced driver assistance system), the ANN model **119** can be deployed on one or more of vehicles **111**, . . . , **113** for usage.

In various embodiments, the ANN model is trained using data as discussed above. The training can be performed on a server and/or the vehicle. Configuration for an ANN model as used in a vehicle can be updated based on the training. The training can be performed in some cases while the vehicle is being operated.

Typically, the vehicles **111**, . . . , **113** have sensors, such as a visible light camera, an infrared camera, a LIDAR, a RADAR, a sonar, and/or a set of peripheral sensors. The sensors of the vehicles **111**, . . . , **113** generate sensor inputs for the ANN model **119** in autonomous driving and/or advanced driver assistance system to generate operating instructions, such as steering, braking, accelerating, driving, alerts, emergency response, etc.

During the operations of the vehicles **111**, . . . , **113** in their respective service environments, the vehicles **111**, . . . , **113** encounter items, such as events or objects, that are captured in the sensor data. The ANN model **119** is used by the vehicles **111**, . . . , **113** to provide the identifications of the items to facilitate the generation of commands for the operations of the vehicles **111**, . . . , **113**, such as for autonomous driving and/or for advanced driver assistance. Capturing of certain of this data can be triggered in response to determining that a braking event has or is occurring. For example, vehicle **113** may determine that a braking event is occurring and activate collection of predetermined types or extent of sensor data (e.g., image data for detected objects).

In one example, a vehicle may communicate, via a wireless connection **115** to an access point (or base station) **105**, with the server **101** to submit the sensor input to enrich the sensor data **103** as an additional dataset for machine learning implemented using the supervised training module **117**. The wireless connection **115** may be made via a wireless local area network, a cellular communications network, and/or a communication link **107** to a satellite **109** or a communication balloon. In one example, user data collected from a vehicle can be similarly transmitted to the server.

Optionally, the sensor input stored in the vehicle may be transferred to another computer for uploading to the centralized server **101**. For example, the sensor input can be transferred to another computer via a memory device, such as a Universal Serial Bus (USB) drive, and/or via a wired computer connection, a Bluetooth or WiFi connection, a diagnosis tool, etc.

Periodically, the server **101** may run the supervised training module **117** to update the ANN model **119** based on updated data that has been received. The server **101** may use the sensor data **103** enhanced with the other data based on prior operation by similar vehicles (e.g., braking event data received from vehicle **113**) that are operated in the same geographical region or in geographical regions having similar traffic conditions (e.g., to generate a customized version of the ANN model **119** for the vehicle **111**).

Optionally, the server **101** uses the sensor data **103** along with object data received from a general population of vehicles (e.g., **111**, **113**) to generate an updated version of the ANN model **119**. The updated ANN model **119** can be downloaded to the current vehicle (e.g., vehicle **111**) via the communications network **102**, the access point (or base station) **105**, and communication links **115** and/or **107** as an over-the-air update of the firmware/software of the vehicle.

Optionally, the vehicle **111** has a self-learning capability. After an extended period on the road, the vehicle **111** may generate a new set of synaptic weights **123**, neuron biases **121**, activation functions **125**, and/or neuron connectivity for the ANN model **119** installed in the vehicle **111** using the sensor inputs it collected and stored in the vehicle **111**. As an example, the centralized server **101** may be operated by a factory, a producer or maker of the vehicles **111**, . . . , **113**, or a vendor of the autonomous driving and/or advanced driver assistance system for vehicles **111**, . . . , **113**.

FIG. 2 shows an example of a vehicle configured using an Artificial Neural Network (ANN) model, according to one embodiment. The vehicle **111** of FIG. 2 includes an infotainment system **149**, a communication device **139**, one or more sensors **137**, and a computer **131** that is connected to some controls of the vehicle **111**, such as a steering control **141** for the direction of the vehicle **111**, a braking control **143** for stopping of the vehicle **111**, an acceleration control **145** for the speed of the vehicle **111**, etc. In some embodiments, vehicle **113** of FIG. 1 has a similar configuration and/or similar components.

The computer **131** of the vehicle **111** includes one or more processors **133**, memory **135** storing firmware (or software) **127**, the ANN model **119** (e.g., as illustrated in FIG. 1), and other data **129**.

In one example, firmware **127** is updated by an over-the-air update in response to a communication from server **101** sent in response to identifying an unsafe location (e.g., located on a road that vehicle **111** is travelling on). Alternatively, and/or additionally, other firmware of various computing devices or systems of vehicle **111** can be updated.

The one or more sensors **137** may include a visible light camera, an infrared camera, a LIDAR, RADAR, or sonar system, and/or peripheral sensors, which are configured to provide sensor input to the computer **131**. A module of the firmware (or software) **127** executed in the processor(s) **133** applies the sensor input to an ANN defined by the model **119** to generate an output that identifies or classifies an event or object captured in the sensor input, such as an image or video clip. Data from this identification and/or classification can be included in object data sent from a vehicle to server **101** as discussed above.

Alternatively, and/or additionally, the identification of an unsafe location and/or classification of a braking event or object generated by the ANN model **119** can be used by an autonomous driving module of the firmware (or software) **127**, or an advanced driver assistance system, to generate a response. The response may be a command to activate and/or adjust one of the vehicle controls **141**, **143**, and **145**. In one embodiment, the response is an action performed by the vehicle where the action has been configured based on an update command from server **101** (e.g., the update command can be generated by server **101** in response to determining that vehicle **111** is approaching a location identified based on analysis of braking event data). In one embodiment, prior to generating the control response, the vehicle is configured. In one embodiment, the configuration of the vehicle is performed by updating firmware of vehicle **111**. In one embodiment, the configuration of the vehicle includes updating of the computer model stored in vehicle **111** (e.g., ANN model **119**).

The server **101** stores the received sensor input as part of the sensor data **103** for the subsequent further training or updating of the ANN model **119** using the supervised training module **117**. When an updated version of the ANN model **119** is available in the server **101**, the vehicle **111** may use the communication device **139** to download the updated ANN model **119** for installation in the memory **135** and/or for the replacement of the previously installed ANN model **119**. These actions may be performed in response to determining that vehicle **111** is failing to properly detect objects and/or in response to identifying an unsafe location.

In one example, the outputs of the ANN model **119** can be used to control (e.g., **141**, **143**, **145**) the acceleration of a vehicle (e.g., **111**), the speed of the vehicle **111**, and/or the direction of the vehicle **111**, during autonomous driving or provision of advanced driver assistance.

Typically, when the ANN model is generated, at least a portion of the synaptic weights **123** of some of the neurons in the network is updated. The update may also adjust some neuron biases **121** and/or change the activation functions **125** of some neurons. In some instances, additional neurons may be added in the network. In other instances, some neurons may be removed from the network.

In one example, data obtained from a sensor of a vehicle may be an image that captures an object using a camera that images using lights visible to human eyes, or a camera that images using infrared lights, or a sonar, radar, or LIDAR system. In one embodiment, image data obtained from at least one sensor of the vehicle is part of the collected data from the vehicle that is analyzed. In some instances, the ANN model is configured for a particular vehicle based on the sensor and other collected data.

FIG. 3 shows a method to identify a location based on determining that braking events correspond to a pattern, according to one embodiment. In block **601**, data is received regarding braking events for vehicles (e.g., vehicle **113** and/or other vehicles). Each braking event occurs on one of the vehicles, and each event is associated with a location at which the braking event occurs.

In block **603**, a determination is made that the braking events correspond to a pattern. The pattern may be, for example, that a predetermined number of the braking events occur within a predetermined distance of one another.

In block **605**, a first location is identified based on determining that the braking events correspond to the pattern. For example, a number of braking events occurring within a predetermined distance can be associated with a location at which the events occurred. In some embodiments, this location can be specified as a defined area, a zone, a physical region or territory, etc.

In block **607**, in response to identifying the first location (e.g., identifying that the first location is unsafe based on various parameters), at least one action is performed. For example, the action can be performed by server **101** (e.g., sending of a communication to current vehicle **111** to cause a control action on the vehicle). In another example, the action can include sending at least one communication to a computing device other than the new vehicle. In one example, the computing device is a server that monitors an operating status for each of one or more vehicles.

In one embodiment, a system includes: at least one processor; and memory storing instructions configured to instruct the at least one processor to: receive data regarding braking events, each event occurring on one of a plurality of vehicles, and each event associated with a location; determine that the braking events correspond to a pattern; identify, based on determining that the braking events correspond to the pattern, a first location; and in response to identifying the first location, perform at least one action.

In one embodiment, determining that the braking events correspond to the pattern comprises comparing a deceleration of the respective vehicle for each of the braking events to a predetermined threshold.

In one embodiment, determining that the braking events correspond to the pattern comprises at least one of: determining that the respective location for each of the braking events is within a predetermined distance of the first location; or determining that a distance between the respective locations for the braking events is within a predetermined value.

13

In one embodiment, each of the braking events corresponds to activation of at least one of an automatic emergency braking system or an anti-lock braking system of the respective vehicle.

In one embodiment, determining that the braking events correspond to the pattern comprises comparing a measurement associated with activation of a braking system of the respective vehicle to a predetermined threshold.

In one embodiment, the measurement is associated with movement of a brake pedal by a user of the respective vehicle.

In one embodiment, the predetermined threshold is a level of pressure or an extent of motion associated with depressing of the brake pedal.

In one embodiment, determining that the braking events correspond to the pattern comprises comparing a number of the braking events that occur within a predetermined time period to a threshold.

In one embodiment, determining that the braking events correspond to the pattern comprises identifying the pattern based at least in part on an output from a machine learning model.

In one embodiment, the machine learning model is an artificial neural network.

In one embodiment, performing the at least one action comprises sending a communication to a first vehicle, the communication causing the first vehicle to perform at least one of controlling an operation of the first vehicle based on an output from an artificial neural network, deactivating an autonomous driving mode of the first vehicle, or controlling a navigation system of the first vehicle.

In one embodiment, the instructions are further configured to instruct the at least one processor to store a map including the respective locations for each of the braking events.

In one embodiment, the instructions are further configured to instruct the at least one processor to provide, based on the map, a navigation service to a first vehicle.

In one embodiment, the data regarding braking events is received by a server that monitors a respective operating status for each of the plurality of vehicles, and monitoring the operating status includes receiving data regarding objects detected by each of the vehicles.

In one embodiment, performing the at least one action is based on an output from a machine learning model, and the machine learning model is trained using training data, the training data comprising data collected by sensors of the plurality of vehicles.

FIG. 4 shows a method to identify a location based on analysis of data regarding braking events for a plurality of vehicles (e.g., vehicle 113 and/or other vehicles), according to one embodiment. In block 611, data is received regarding braking events occurring on the vehicles. The data includes a location for each braking event.

In block 613, the received data is analyzed. For example, braking event data 161 and event location data 163 can be analyzed to determine that the data corresponds to a pattern and/or other correlation.

In block 615, based on analyzing the received data, a first location is identified. For example, the location can be identified by geographic coordinates and a type of condition associated with the result of the analysis. This type of condition can, for example, be communicated to a vehicle for use in determining a control action.

14

In block 617, in response to identifying the first location, one or more actions are performed. These actions can be performed by, for example, server 101, server 301, or server 701.

In one embodiment, a method includes: receiving, by at least one processor, data regarding braking events occurring on a plurality of vehicles, the data including a location for each of the braking events; analyzing, by the at least one processor, the received data; identifying, based on analyzing the received data, a first location; and in response to identifying the first location, performing at least one action.

In one embodiment, performing the at least one action comprises configuring, based on analyzing the received data, a first vehicle, wherein the first vehicle is an autonomous vehicle comprising a controller and a storage device, wherein configuring the first vehicle comprises updating firmware of the controller, and wherein the updated firmware is stored in the storage device.

In one embodiment, the method further comprises, in response to identifying the first location, analyzing image data associated with the first location, wherein analyzing the image data comprises performing pattern recognition on image data to determine at least one object associated with the first location.

In one embodiment, analyzing the received data comprises determining that the respective locations for the braking events are within a predetermined area.

In one embodiment, a non-transitory computer storage medium stores instructions which, when executed on a computing device, cause the computing device to perform a method comprising: receiving, by at least one processor, data regarding braking events occurring on a plurality of vehicles, the data including a location for each of the braking events; analyzing, by the at least one processor, the received data; and in response to analyzing the received data, performing at least one action.

FIG. 5 shows an autonomous vehicle 303 controlled and/or configured in response to identifying a location associated with braking events, according to one embodiment. A system controls a display device 308 or other device, system, or component of an autonomous vehicle 303. For example, a controller 307 controls the display of images on one or more display devices 308. Controller 307 also controls navigation of the vehicle (e.g. using braking control 143 of FIG. 2).

Server 301 may store, for example, map data 160. Server 301 may determine, using map data 160, that vehicle 303 is approaching an unsafe location (and/or is failing to properly detect objects). In response to this determination, server 301 may cause the controller 307 to terminate an autonomous navigation mode. Other actions can be performed in response to this determination including, for example, configuring a vehicle 303 by updating firmware 304, updating computer model 312, updating data in database 310, and/or updating training data 314.

The controller 307 may receive data collected by one or more sensors 306. The sensors 306 may be, for example, mounted in the autonomous vehicle 303. The sensors 306 may include, for example, a camera, a microphone, a motion detector, and/or a camera. At least a portion of the sensors may provide data associated with objects newly detected by vehicle 303 during travel.

The sensors 306 may provide various types of data for collection by the controller 307. For example, the collected data may include image data from the camera and/or audio data from the microphone.

In one embodiment, the controller 307 analyzes the collected data from the sensors 306. The analysis of the collected data includes providing some or all of the collected data as one or more inputs to a computer model 312. The computer model 312 can be, for example, an artificial neural network trained by deep learning. In one example, the computer model is a machine learning model that is trained using training data 314. The computer model 312 and/or the training data 314 can be stored, for example, in memory 309. An output from the computer model 312 can be transmitted to server 301 as part of object data for comparison to map data 160.

In one embodiment, memory 309 stores a database 310, which may include data collected by sensors 306 and/or data received by a communication interface 305 from computing device, such as, for example, a server 301 (server 301 can be, for example, server 101 of FIG. 1 in some embodiments). In one example, this communication may be used to wirelessly transmit collected data from the sensors 306 to the server 301. The received data may include configuration, training, and other data used to configure control of the display devices 308 or other components by controller 307.

In one example, the received data may include data collected from sensors of autonomous vehicles other than autonomous vehicle 303. This data may be included, for example, in training data 314 for training of the computer model 312. The received data may also be used to update a configuration of a machine learning model stored in memory 309 as computer model 312.

In FIG. 5, firmware 304 controls, for example, the operations of the controller 307 in controlling the display devices 308 and other components of vehicle 303. The controller 307 also can, for example, run the firmware 304 to perform operations responsive to communications from the server 301. The autonomous vehicle 303 includes volatile Dynamic Random-Access Memory (DRAM) 311 for the storage of run-time data and instructions used by the controller 307.

In one embodiment, memory 309 is implemented using various memory/storage technologies, such as NAND gate based flash memory, phase-change memory (PCM), magnetic memory (MRAM), resistive random-access memory, and 3D XPoint, such that the memory 309 is non-volatile and can retain data stored therein without power for days, months, and/or years.

In one embodiment server 301 communicates with the communication interface 305 via a communication channel. In one embodiment, the server 301 can be a computer having one or more Central Processing Units (CPUs) to which vehicles, such as the autonomous vehicle 303, may be connected using a computer network. For example, in some implementations, the communication channel between the server 301 and the communication interface 305 includes a computer network, such as a local area network, a wireless local area network, a cellular communications network, or a broadband high-speed always-connected wireless communication connection (e.g., a current or future generation of mobile network link).

In one embodiment, the controller 307 performs data intensive, in-memory processing using data and/or instructions organized in memory 309 or otherwise organized in the autonomous vehicle 303. For example, the controller 307 can perform a real-time analysis of a set of data collected and/or stored in the autonomous vehicle 303. In some embodiments, the set of data further includes collected or configuration update data obtained from server 301.

At least some embodiments of the systems and methods disclosed herein can be implemented using computer

instructions executed by the controller 307, such as the firmware 304. In some instances, hardware circuits can be used to implement at least some of the functions of the firmware 304. The firmware 304 can be initially stored in non-volatile storage media, such as by using memory 309, or another non-volatile device, and loaded into the volatile DRAM 311 and/or the in-processor cache memory for execution by the controller 307. In one example, the firmware 104 can be configured to use the techniques discussed herein for controlling display or other devices of a vehicle as configured based on collected user data.

FIG. 6 shows a vehicle 703 controlled and/or configured via a communication interface using a cloud service, according to one embodiment. For example, vehicle 703 receives a control communication and/or is configured in response to a determination by server 701 that vehicle 703 is approaching an unsafe location identified, at least in part, based on braking event data received from other vehicles.

The vehicle 703 includes a communication interface 705 used to receive a configuration update, which is based on analysis of collected object data. For example, the update can be received from server 701 and/or client device 719. Communication amongst two or more of the vehicle 703, a server 701, and a client device 719 can be performed over a network 715 (e.g., a wireless network). This communication is performed using communication interface 705.

In one embodiment, the server 701 controls the loading of configuration data (e.g., based on analysis of collected data) of the new configuration into the memory 709 of the vehicle. In one embodiment, data associated with usage of vehicle 703 is stored in a memory 721 of client device 719.

A controller 707 controls one or more operations of the vehicle 703. For example, controller 707 controls user data 714 stored in memory 709. Controller 707 also controls loading of updated configuration data into memory 709 and/or other memory of the vehicle 703. Controller 707 also controls display of information on display device(s) 708. Sensor(s) 706 provide data regarding operation of the vehicle 703. At least a portion of this operational data can be communicated to the server 701 and/or the client device 719.

Memory 709 can further include, for example, configuration data 712 and/or database 710. Configuration data 712 can be, for example, data associated with operation of the vehicle 703 as provided by the server 701. The configuration data 712 can be, for example, based on collected and/or analyzed object data (including braking event data received by server 701 from vehicles).

Database 710 can store, for example, configuration data for a user and/or data collected by sensors 706. Database 710 also can store, for example, navigational maps and/or other data provided by the server 701.

In one embodiment, when a vehicle is being operated, data regarding object detection activity of vehicle 703 can be communicated to server 701. This activity may include navigational and/or other operational aspects of the vehicle 703.

As illustrated in FIG. 6, controller 707 also may control the display of images on one or more display devices 708 (e.g., an alert to the user can be displayed in response to determining by server 701 and/or controller 707 that vehicle 703 is failing to properly detect objects). Display device 708 can be a liquid crystal display. The controller 707 may receive data collected by one or more sensors 706. The sensors 706 may be, for example, mounted in the vehicle 703. The sensors 706 may include, for example, a camera, a microphone, a motion detector, and/or a camera.

The sensors **706** may provide various types of data for collection and/or analysis by the controller **707**. For example, the collected data may include image data from the camera and/or audio data from the microphone. In one embodiment, the image data includes images of one or more new objects encountered by vehicle **703** during travel.

In one embodiment, the controller **707** analyzes the collected data from the sensors **706**. The analysis of the collected data includes providing some or all of the object data to server **701**.

In one embodiment, memory **709** stores database **710**, which may include data collected by sensors **706** and/or configuration data received by communication interface **705** from a computing device, such as, for example, server **701**. For example, this communication may be used to wirelessly transmit collected data from the sensors **706** to the server **701**. The data received by the vehicle may include configuration or other data used to configure control of navigation, display, or other devices by controller **707**.

In FIG. **6**, firmware **704** controls, for example, the operations of the controller **707**. The controller **707** also can, for example, run the firmware **704** to perform operations responsive to communications from the server **701**.

The vehicle **703** includes volatile Dynamic Random-Access Memory (DRAM) **711** for the storage of run-time data and instructions used by the controller **707** to improve the computation performance of the controller **707** and/or provide buffers for data transferred between the server **701** and memory **709**. DRAM **711** is volatile.

FIG. **7** is a block diagram of an autonomous vehicle including one or more various components and/or subsystems, each of which can be updated in various embodiments to configure the vehicle and/or perform other actions associated with the vehicle (e.g., configuration and/or other actions performed in response to identifying a location based on analyzing braking events of a plurality of vehicles). The system illustrated in FIG. **7** may be installed entirely within a vehicle.

The system includes an autonomous vehicle subsystem **402**. In the illustrated embodiment, autonomous vehicle subsystem **402** includes map database **402A**, radar devices **402B**, Lidar devices **402C**, digital cameras **402D**, sonar devices **402E**, GPS receivers **402F**, and inertial measurement units **402G**. Each of the components of autonomous vehicle subsystem **402** comprise standard components provided in most current autonomous vehicles. In one embodiment, map database **402A** stores a plurality of high-definition three-dimensional maps used for routing and navigation. Radar devices **402B**, Lidar devices **402C**, digital cameras **402D**, sonar devices **402E**, GPS receivers **402F**, and inertial measurement units **402G** may comprise various respective devices installed at various positions throughout the autonomous vehicle as known in the art. For example, these devices may be installed along the perimeter of an autonomous vehicle to provide location awareness, collision avoidance, and other standard autonomous vehicle functionality.

Vehicular subsystem **406** is additionally included within the system. Vehicular subsystem **406** includes various anti-lock braking systems **406A**, engine control units **402B**, and transmission control units **402C**. These components may be utilized to control the operation of the autonomous vehicle in response to the streaming data generated by autonomous vehicle subsystem **402A**. The standard autonomous vehicle interactions between autonomous vehicle subsystem **402** and vehicular subsystem **406** are generally known in the art and are not described in detail herein.

The processing side of the system includes one or more processors **410**, short-term memory **412**, an RF system **414**, graphics processing units (GPUs) **416**, long-term storage **418** and one or more interfaces **420**.

The one or more processors **410** may comprise central processing units, FPGAs, or any range of processing devices needed to support the operations of the autonomous vehicle. Memory **412** comprises DRAM or other suitable volatile RAM for temporary storage of data required by processors **410**. RF system **414** may comprise a cellular transceiver and/or satellite transceiver. Long-term storage **418** may comprise one or more high-capacity solid-state drives (SSDs). In general, long-term storage **418** may be utilized to store, for example, high-definition maps, routing data, and any other data requiring permanent or semi-permanent storage. GPUs **416** may comprise one more high throughput GPU devices for processing data received from autonomous vehicle subsystem **402A**. Finally, interfaces **420** may comprise various display units positioned within the autonomous vehicle (e.g., an in-dash screen).

The system additionally includes a reporting subsystem **404** which performs data collection (e.g., collection of data obtained from sensors of the vehicle that is used to drive the vehicle). The reporting subsystem **404** includes a sensor monitor **404A** which is connected to bus **408** and records sensor data transmitted on the bus **408** as well as any log data transmitted on the bus. The reporting subsystem **404** may additionally include one or more endpoints to allow for system components to transmit log data directly to the reporting subsystem **404**.

The reporting subsystem **404** additionally includes a packager **404B**. In one embodiment, packager **404B** retrieves the data from the sensor monitor **404A** or endpoints and packages the raw data for transmission to a central system (illustrated in FIG. **8**). In some embodiments, packager **404B** may be configured to package data at periodic time intervals. Alternatively, or in conjunction with the foregoing, packager **404B** may transmit data in real-time and may compress data to facilitate real-time communications with a central system.

The reporting subsystem **404** additionally includes a batch processor **404C**. In one embodiment, the batch processor **404C** is configured to perform any preprocessing on recorded data prior to transmittal. For example, batch processor **404C** may perform compression operations on the data prior to packaging by packager **404B**. In another embodiment, batch processor **404C** may be configured to filter the recorded data to remove extraneous data prior to packaging or transmittal. In another embodiment, batch processor **404C** may be configured to perform data cleaning on the recorded data to conform the raw data to a format suitable for further processing by the central system.

Each of the devices is connected via a bus **408**. In one embodiment, the bus **408** may comprise a controller area network (CAN) bus. In some embodiments, other bus types may be used (e.g., a FlexRay or MOST bus). Additionally, each subsystem may include one or more additional busses to handle internal subsystem communications (e.g., LIN busses for lower bandwidth communications).

FIG. **8** is a block diagram of a centralized autonomous vehicle operations system, according to various embodiments. As illustrated, the system includes a number of autonomous vehicles **502A-502E**. In one embodiment, each autonomous vehicle may comprise an autonomous vehicle such as that depicted in FIG. **7**. Each autonomous vehicle **502A-502E** may communicate with a central system **514** via

a network **516**. In one embodiment, network **516** comprises a global network such as the Internet.

In one example, central system **514** is implemented using one or more of servers **101**, **301**, and/or **701**. In one example, one or more of autonomous vehicles **502A-502E** are autonomous vehicle **703**.

The system additionally includes a plurality of client devices **508A**, **508B**. In the illustrated embodiment, client devices **508A**, **508B** may comprise any personal computing device (e.g., a laptop, tablet, mobile phone, etc.). Client devices **508A**, **508B** may issue requests for data from central system **514**. In one embodiment, client devices **508A**, **508B** transmit requests for data to support mobile applications or web page data, as described previously.

In one embodiment, central system **514** includes a plurality of servers **504A**. In one embodiment, servers **504A** comprise a plurality of front end webservers configured to serve responses to client device **508A**, **508B**. The servers **504A** may additionally include one or more application servers configured to perform various operations to support one or more vehicles.

In one embodiment, central system **514** additionally includes a plurality of models **504B**. In one embodiment, models **504B** may store one or more neural networks for classifying autonomous vehicle objects. The models **504B** may additionally include models for predicting future events. In some embodiments the models **504B** may store a combination of neural networks and other machine learning models.

Central system **514** additionally includes one or more databases **504C**. The databases **504C** may include database record for vehicles **504D**, personalities **504E**, and raw data **504F**. Raw data **504F** may comprise an unstructured database for storing raw data received from sensors and logs as discussed previously.

The present disclosure includes methods and apparatuses which perform the methods described above, including data processing systems which perform these methods, and computer readable media containing instructions which when executed on data processing systems cause the systems to perform these methods.

Each of the server **101** and the computer **131** of a vehicle **111**, . . . , or **113** can be implemented as one or more data processing systems. A typical data processing system may include an inter-connect (e.g., bus and system core logic), which interconnects a microprocessor(s) and memory. The microprocessor is typically coupled to cache memory.

The inter-connect interconnects the microprocessor(s) and the memory together and also interconnects them to input/output (I/O) device(s) via I/O controller(s). I/O devices may include a display device and/or peripheral devices, such as mice, keyboards, modems, network interfaces, printers, scanners, video cameras and other devices known in the art. In one embodiment, when the data processing system is a server system, some of the I/O devices, such as printers, scanners, mice, and/or keyboards, are optional.

The inter-connect can include one or more buses connected to one another through various bridges, controllers and/or adapters. In one embodiment the I/O controllers include a USB (Universal Serial Bus) adapter for controlling USB peripherals, and/or an IEEE-1394 bus adapter for controlling IEEE-1394 peripherals.

The memory may include one or more of: ROM (Read Only Memory), volatile RAM (Random Access Memory), and non-volatile memory, such as hard drive, flash memory, etc.

Volatile RAM is typically implemented as dynamic RAM (DRAM) which requires power continually in order to refresh or maintain the data in the memory. Non-volatile memory is typically a magnetic hard drive, a magnetic optical drive, an optical drive (e.g., a DVD RAM), or other type of memory system which maintains data even after power is removed from the system. The non-volatile memory may also be a random access memory.

The non-volatile memory can be a local device coupled directly to the rest of the components in the data processing system. A non-volatile memory that is remote from the system, such as a network storage device coupled to the data processing system through a network interface such as a modem or Ethernet interface, can also be used.

In the present disclosure, some functions and operations are described as being performed by or caused by software code to simplify description. However, such expressions are also used to specify that the functions result from execution of the code/instructions by a processor, such as a microprocessor.

Alternatively, or in combination, the functions and operations as described here can be implemented using special purpose circuitry, with or without software instructions, such as using Application-Specific Integrated Circuit (ASIC) or Field-Programmable Gate Array (FPGA). Embodiments can be implemented using hardwired circuitry without software instructions, or in combination with software instructions. Thus, the techniques are limited neither to any specific combination of hardware circuitry and software, nor to any particular source for the instructions executed by the data processing system.

While one embodiment can be implemented in fully functioning computers and computer systems, various embodiments are capable of being distributed as a computing product in a variety of forms and are capable of being applied regardless of the particular type of machine or computer-readable media used to actually effect the distribution.

At least some aspects disclosed can be embodied, at least in part, in software. That is, the techniques may be carried out in a computer system or other data processing system in response to its processor, such as a microprocessor, executing sequences of instructions contained in a memory, such as ROM, volatile RAM, non-volatile memory, cache or a remote storage device.

Routines executed to implement the embodiments may be implemented as part of an operating system or a specific application, component, program, object, module or sequence of instructions referred to as "computer programs." The computer programs typically include one or more instructions set at various times in various memory and storage devices in a computer, and that, when read and executed by one or more processors in a computer, cause the computer to perform operations necessary to execute elements involving the various aspects.

A machine readable medium can be used to store software and data which when executed by a data processing system causes the system to perform various methods. The executable software and data may be stored in various places including for example ROM, volatile RAM, non-volatile memory and/or cache. Portions of this software and/or data may be stored in any one of these storage devices. Further, the data and instructions can be obtained from centralized

servers or peer to peer networks. Different portions of the data and instructions can be obtained from different centralized servers and/or peer to peer networks at different times and in different communication sessions or in a same communication session. The data and instructions can be obtained in entirety prior to the execution of the applications. Alternatively, portions of the data and instructions can be obtained dynamically, just in time, when needed for execution. Thus, it is not required that the data and instructions be on a machine readable medium in entirety at a particular instance of time.

Examples of computer-readable media include but are not limited to non-transitory, recordable and non-recordable type media such as volatile and non-volatile memory devices, read only memory (ROM), random access memory (RAM), flash memory devices, floppy and other removable disks, magnetic disk storage media, optical storage media (e.g., Compact Disk Read-Only Memory (CD ROM), Digital Versatile Disks (DVDs), etc.), among others. The computer-readable media may store the instructions.

The instructions may also be embodied in digital and analog communication links for electrical, optical, acoustical or other forms of propagated signals, such as carrier waves, infrared signals, digital signals, etc. However, propagated signals, such as carrier waves, infrared signals, digital signals, etc. are not tangible machine readable medium and are not configured to store instructions.

In general, a machine readable medium includes any mechanism that provides (i.e., stores and/or transmits) information in a form accessible by a machine (e.g., a computer, network device, personal digital assistant, manufacturing tool, any device with a set of one or more processors, etc.).

In various embodiments, hardwired circuitry may be used in combination with software instructions to implement the techniques. Thus, the techniques are neither limited to any specific combination of hardware circuitry and software nor to any particular source for the instructions executed by the data processing system.

The above description and drawings are illustrative and are not to be construed as limiting. Numerous specific details are described to provide a thorough understanding. However, in certain instances, well known or conventional details are not described in order to avoid obscuring the description. References to one or an embodiment in the present disclosure are not necessarily references to the same embodiment; and, such references mean at least one.

In the foregoing specification, the disclosure has been described with reference to specific exemplary embodiments thereof. It will be evident that various modifications may be made thereto without departing from the broader spirit and scope as set forth in the following claims. The specification and drawings are, accordingly, to be regarded in an illustrative sense rather than a restrictive sense.

What is claimed is:

1. An apparatus comprising:

at least one processor; and

memory storing instructions configured to instruct the at least one processor to:

determine that a first vehicle of a plurality of autonomous vehicles is failing to properly detect objects when operating in an autonomous driving mode, wherein the first vehicle comprises a storage device configured to store an artificial neural network (ANN) model; and

in response to determining that the first vehicle is failing to properly detect objects, send a communication to the first vehicle, the communication caus-

ing the first vehicle to deactivate the autonomous driving mode of the first vehicle.

2. The apparatus of claim 1, wherein the communication further causes updating firmware of a controller of the first vehicle.

3. The apparatus of claim 1, wherein the first vehicle comprises the storage device configured to store the ANN model used to detect objects when operating in the autonomous driving mode.

4. The apparatus of claim 3, wherein the instructions are further configured to instruct the at least one processor to: in response to determining that the first vehicle is failing to properly detect objects, send updated firmware to the first vehicle;

wherein the updated firmware is stored in the storage device, and the updated firmware is used by the first vehicle to update the ANN model.

5. The apparatus of claim 3, wherein the ANN model is trained using training data, and the training data comprises data collected by sensors of the autonomous vehicles.

6. The apparatus of claim 1, wherein the instructions are further configured to instruct the at least one processor to: store a map based on data regarding braking events received from the vehicles other than the first vehicle; and

provide, based on the map, a navigation service to the first vehicle.

7. The apparatus of claim 1, wherein the instructions are further configured to instruct the at least one processor to: identify, based on braking events associated with the vehicles, a first location;

in response to identifying the first location, analyze image data associated with the first location, the analyzing comprising performing pattern recognition on image data to determine at least one object associated with the first location.

8. The apparatus of claim 1, wherein the instructions are further configured to instruct the at least one processor to: receive data regarding braking events, each event occurring on one of the autonomous vehicles, and each event associated with a location;

determine that the braking events correspond to a pattern; identify, based on determining that the braking events correspond to the pattern, a first location;

wherein determining that the first vehicle is failing to properly detect objects comprises determining that the first vehicle is failing to properly detect objects at the identified first location.

9. The apparatus of claim 8, wherein determining that the braking events correspond to the pattern comprises identifying the pattern based at least in part on an output from a machine learning model.

10. An apparatus comprising:

at least one processor; and

memory storing instructions configured to instruct the at least one processor to:

identify, based on data received regarding braking events of one of a plurality of vehicles, a first location;

determine that a first vehicle of the vehicles is failing to properly detect objects at the first location, wherein the first vehicle comprises a storage device configured to store an artificial neural network (ANN) model; and

in response to determining that the first vehicle is failing to properly detect the objects, control a navigation system of the first vehicle.

23

11. The apparatus of claim 10, wherein the instructions are further configured to instruct the at least one processor to: store a map based on data regarding braking events received from the vehicles; and provide, based on the map, a navigation service to the first vehicle.

12. The apparatus of claim 10, wherein identifying the first location comprises determining that the respective locations for the braking events are within a predetermined area.

13. The apparatus of claim 10, wherein identifying the first location comprises comparing a deceleration of the respective vehicle for each of the braking events to a predetermined threshold.

14. The apparatus of claim 10, wherein identifying the first location comprises at least one of:
 determining that the respective location for each of the braking events is within a predetermined distance of the first location; or
 determining that a distance between the respective locations for the braking events is within a predetermined value.

15. The apparatus of claim 10, wherein each of the braking events corresponds to activation of at least one of an automatic emergency braking system or an anti-lock braking system of the respective vehicle.

16. The apparatus of claim 10, wherein identifying the first location comprises comparing a measurement associated with activation of a braking system of the respective vehicle to a predetermined threshold.

24

17. The apparatus of claim 16, wherein the measurement is associated with movement of a brake pedal by a user of the respective vehicle.

18. The apparatus of claim 17, wherein the predetermined threshold is a level of pressure or an extent of motion associated with depressing of the brake pedal.

19. The apparatus of claim 10, wherein identifying the first location comprises comparing a number of the braking events that occur within a predetermined time period to a threshold.

20. The apparatus of claim 10, wherein the communication further causes the first vehicle to control an operation of the first vehicle based on an output from an artificial neural network.

21. A method comprising:
 identifying, based on data received regarding braking events occurring on one of a plurality of autonomous vehicles, a first location;
 determining that a first vehicle of the vehicles is failing to properly detect objects at the first location, wherein the first vehicle comprises a storage device configured to store an artificial neural network (ANN) model; and
 in response to determining that the first vehicle is failing to properly detect the objects, deactivating an autonomous driving mode of the first vehicle.

22. The method of claim 21, wherein the objects include at least one first object, and wherein the first vehicle stores the ANN model used to detect the first object when operating in the autonomous driving mode.

* * * * *