



US 20190223561A1

(19) **United States**

(12) **Patent Application Publication**  
**Kojima et al.**

(10) **Pub. No.: US 2019/0223561 A1**

(43) **Pub. Date: Jul. 25, 2019**

(54) **SLIDER AND SLIDE FASTENER**

(52) **U.S. Cl.**

(71) Applicant: **YKK Corporation**, Tokyo (JP)

CPC ..... **A44B 19/262** (2013.01)

(72) Inventors: **Masayoshi Kojima**, Kurobe-shi, Toyama (JP); **Hideki Sato**, Kurobe-shi, Toyama (JP); **Takayuki Inukai**, Kurobe-shi, Toyama (JP)

(57) **ABSTRACT**

(21) Appl. No.: **16/336,054**

A slider includes a slider body and a pull. The slider body includes an upper blade and a lower blade arranged to be spaced from each other in an up-down direction and to be parallel to each other, a guide post connecting the upper blade and the lower blade, and a pull attachment portion provided on an upper surface of the upper blade. The pull is attached to the pull attachment portion. A cut-out portion is formed on a front end portion of the upper blade at one of left and right sides with respect to the guide post. The cut-out portion is formed to be positioned at a rear side than a front end portion of the upper blade at the other of the left and right sides with respect to the guide post and than a front end portion of the lower blade.

(22) PCT Filed: **Sep. 26, 2016**

(86) PCT No.: **PCT/JP2016/078253**

§ 371 (c)(1),

(2) Date: **Mar. 22, 2019**

**Publication Classification**

(51) **Int. Cl.**

**A44B 19/26**

(2006.01)

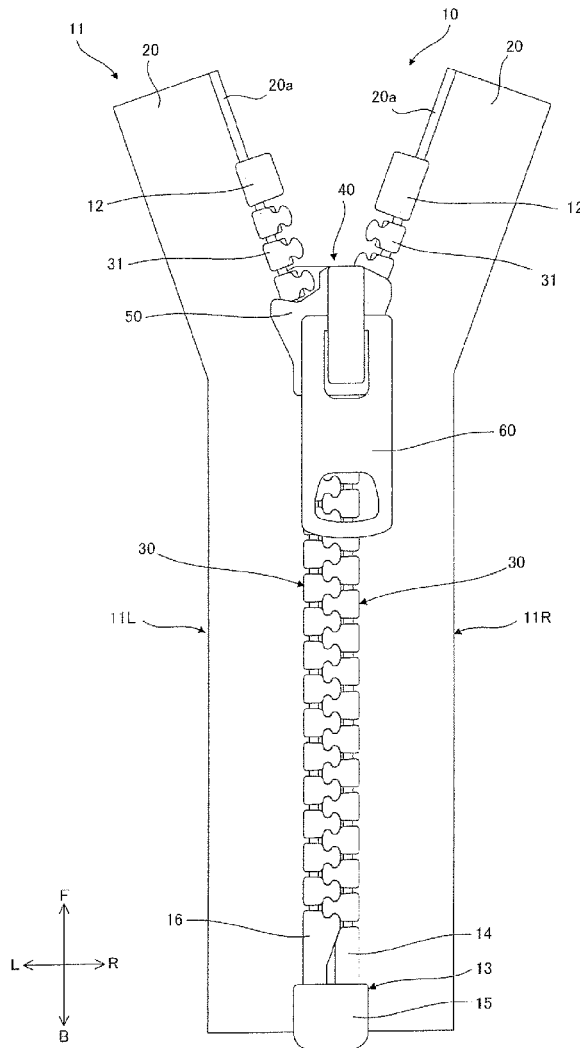

Fig. 1

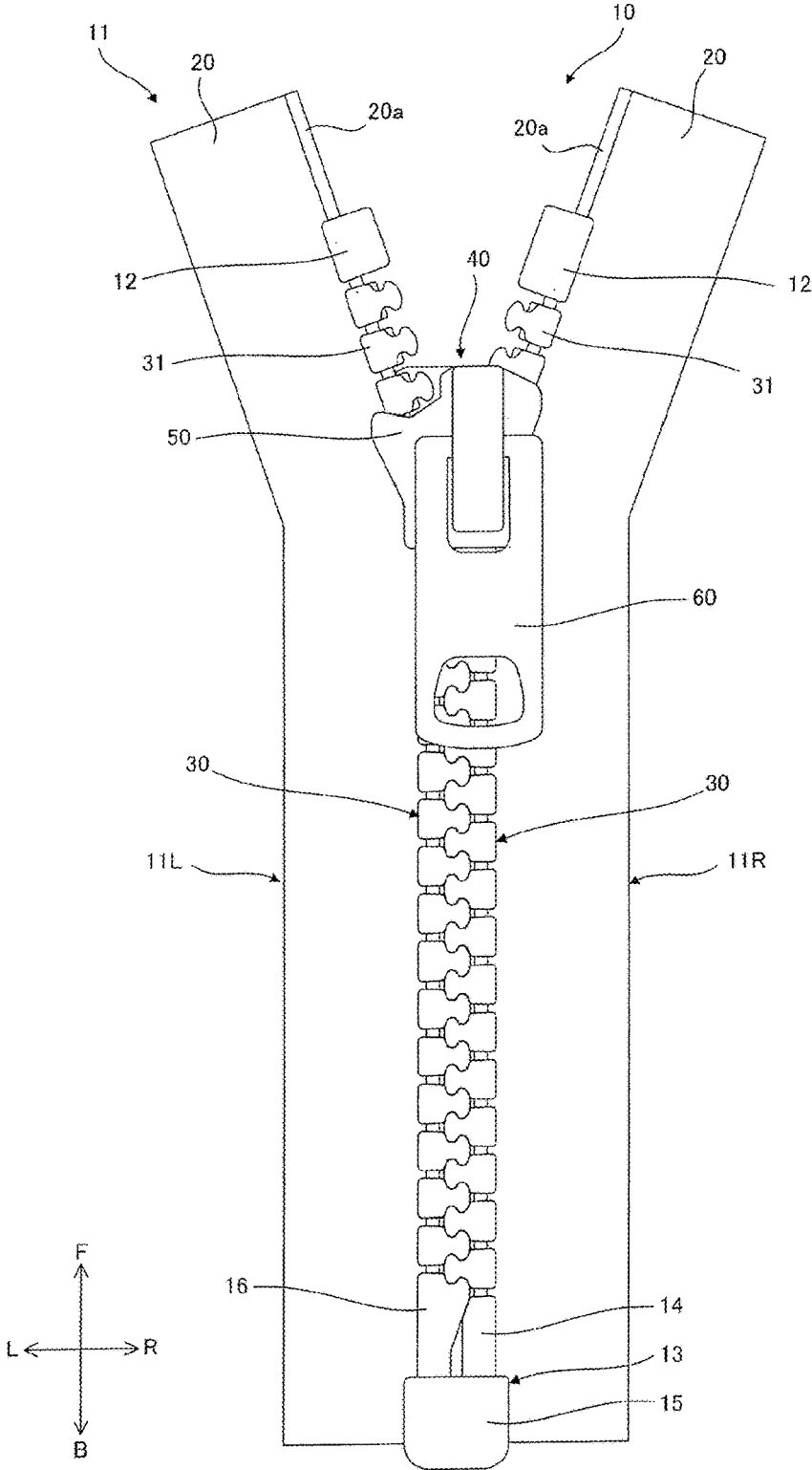

Fig. 2

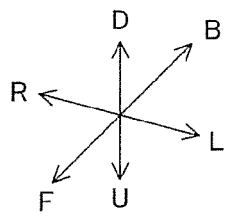
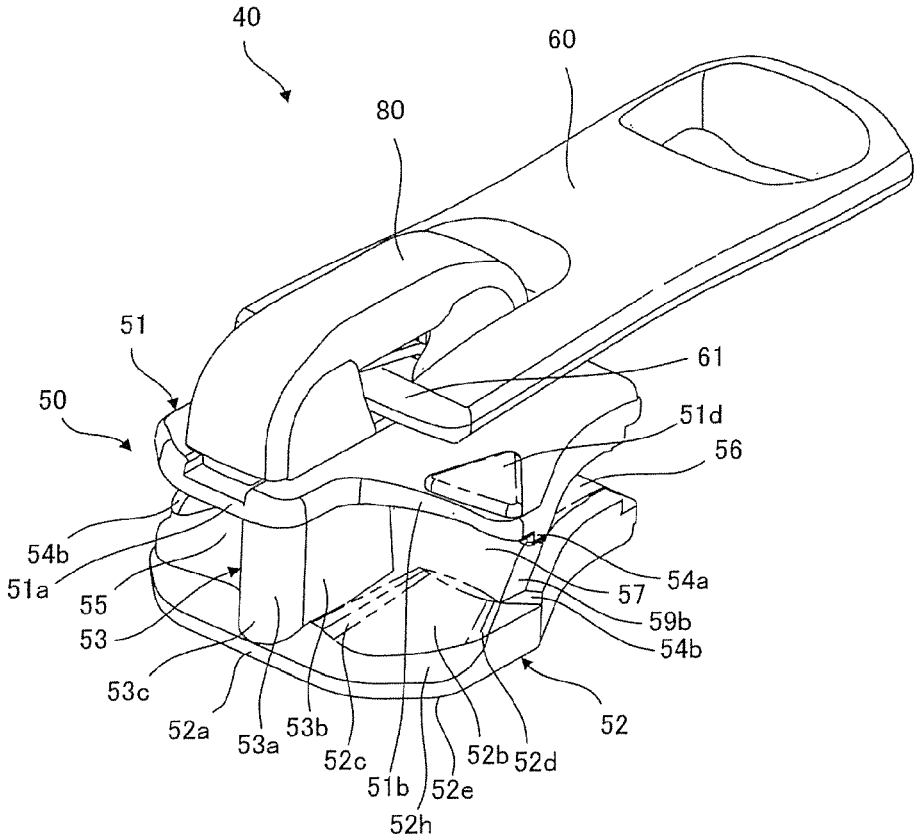
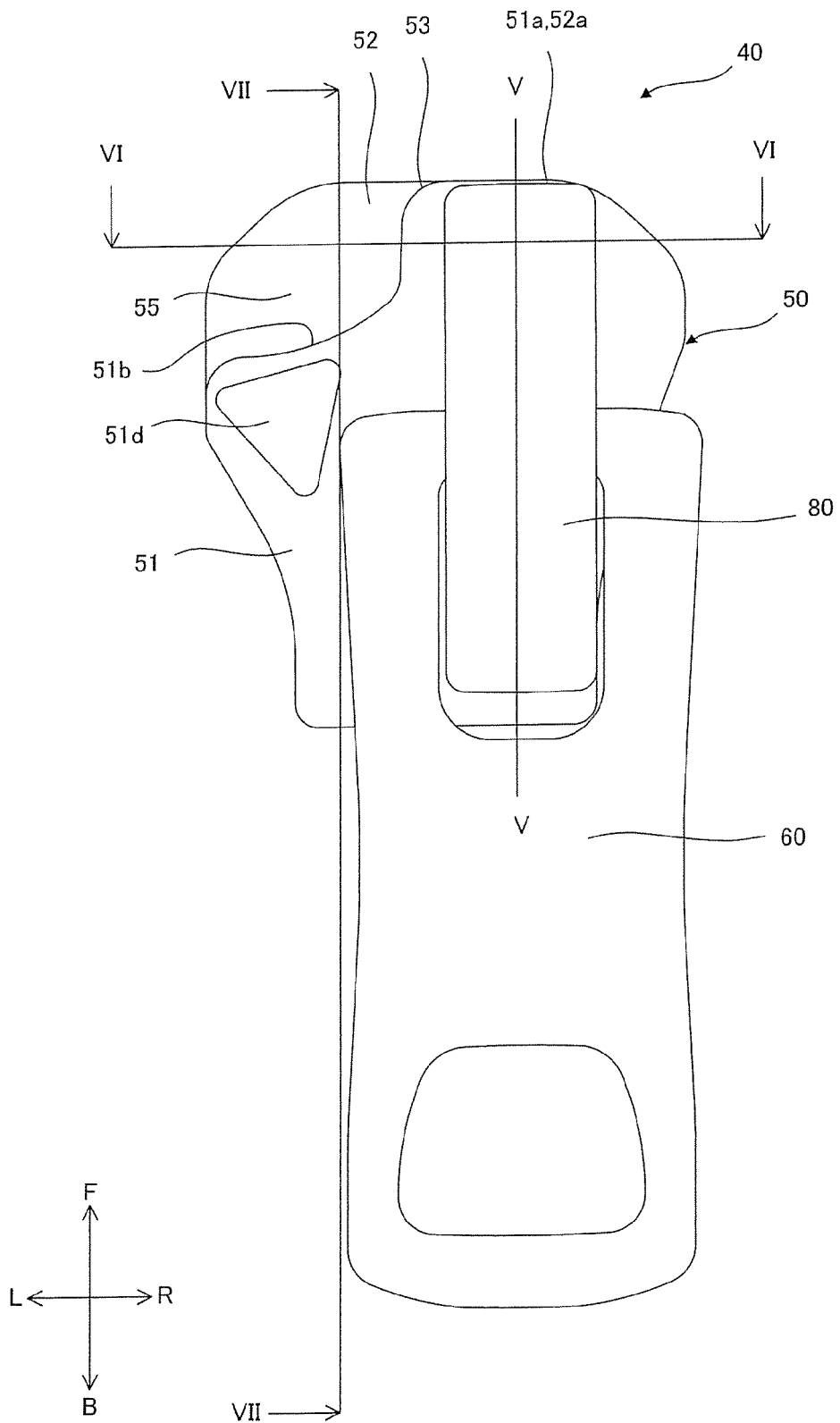
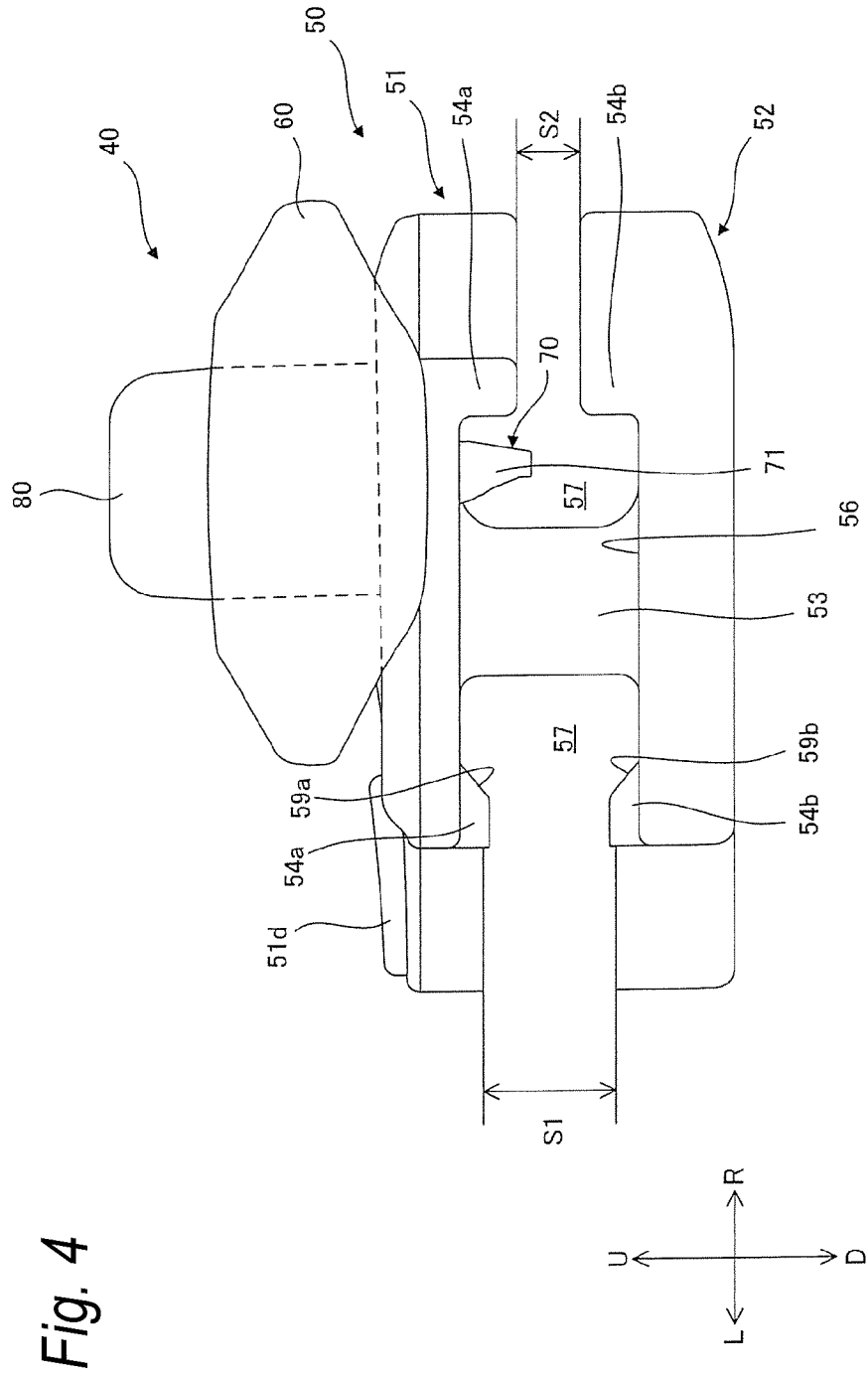

Fig. 3





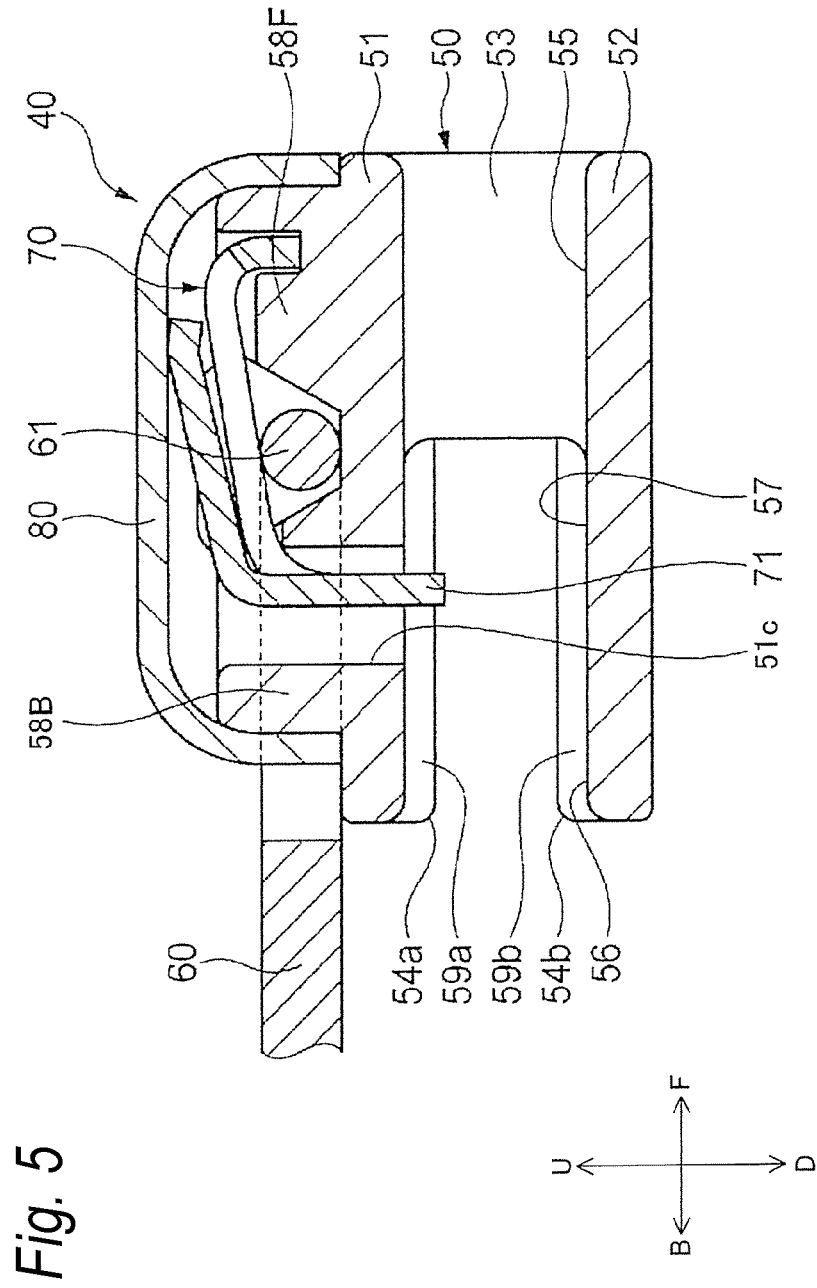

Fig. 5

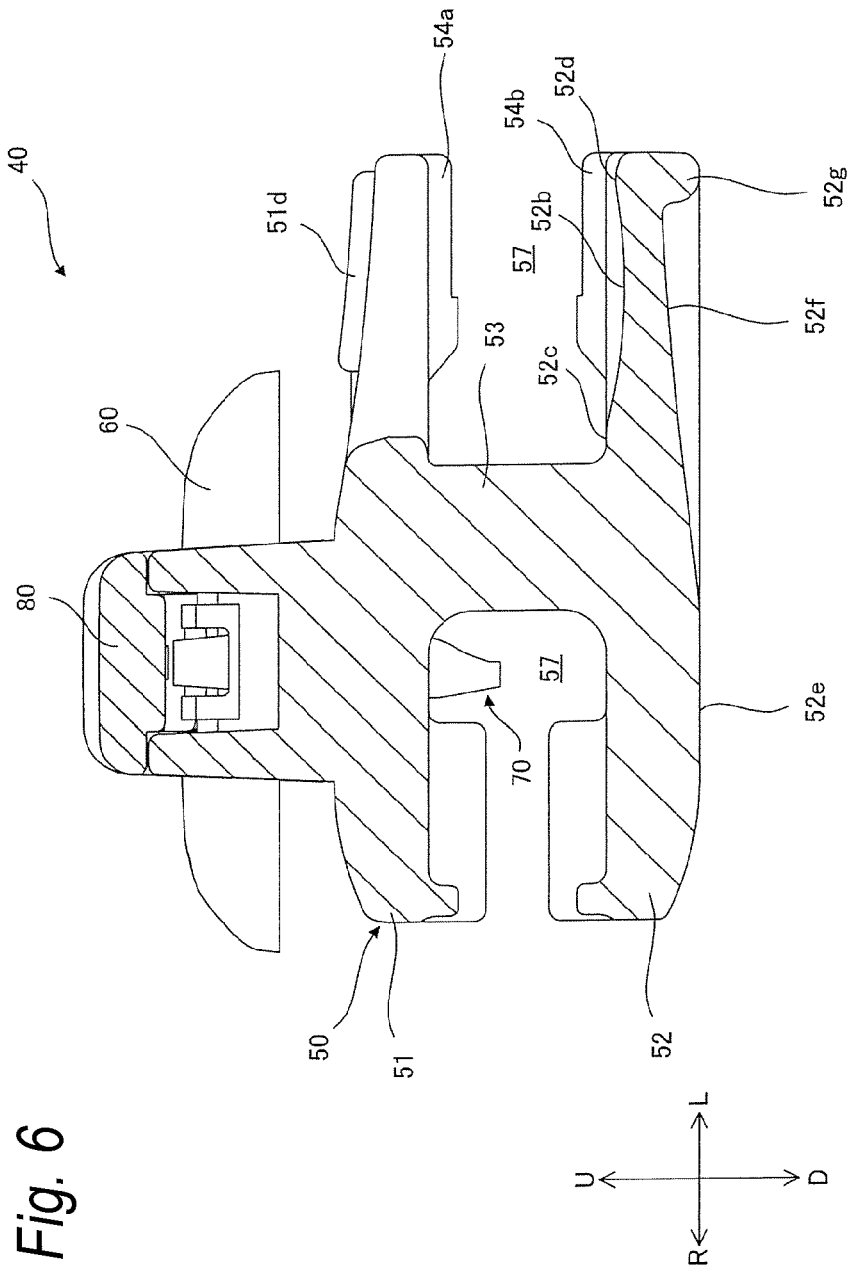

Fig. 6

Fig. 7

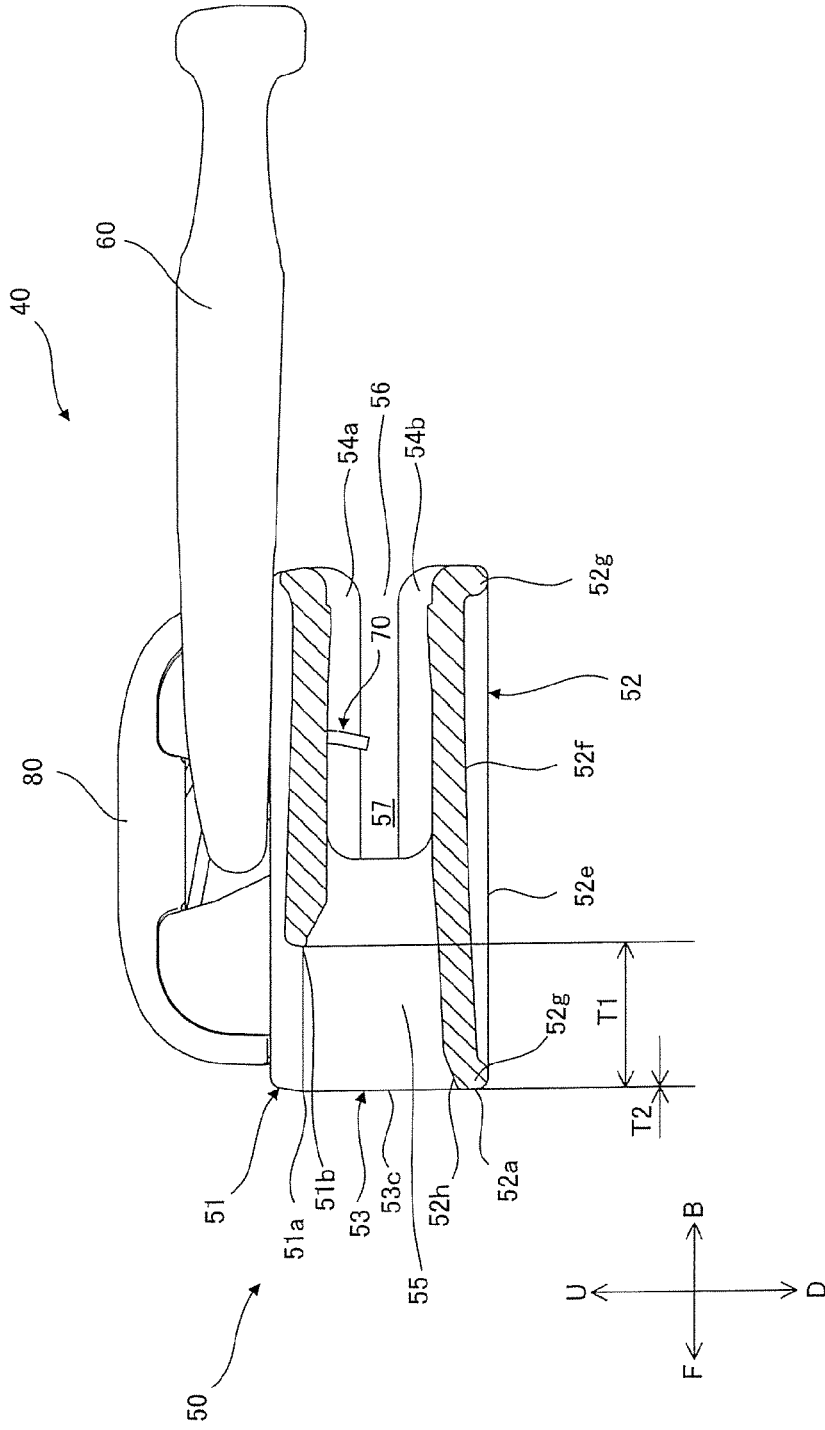





Fig. 9

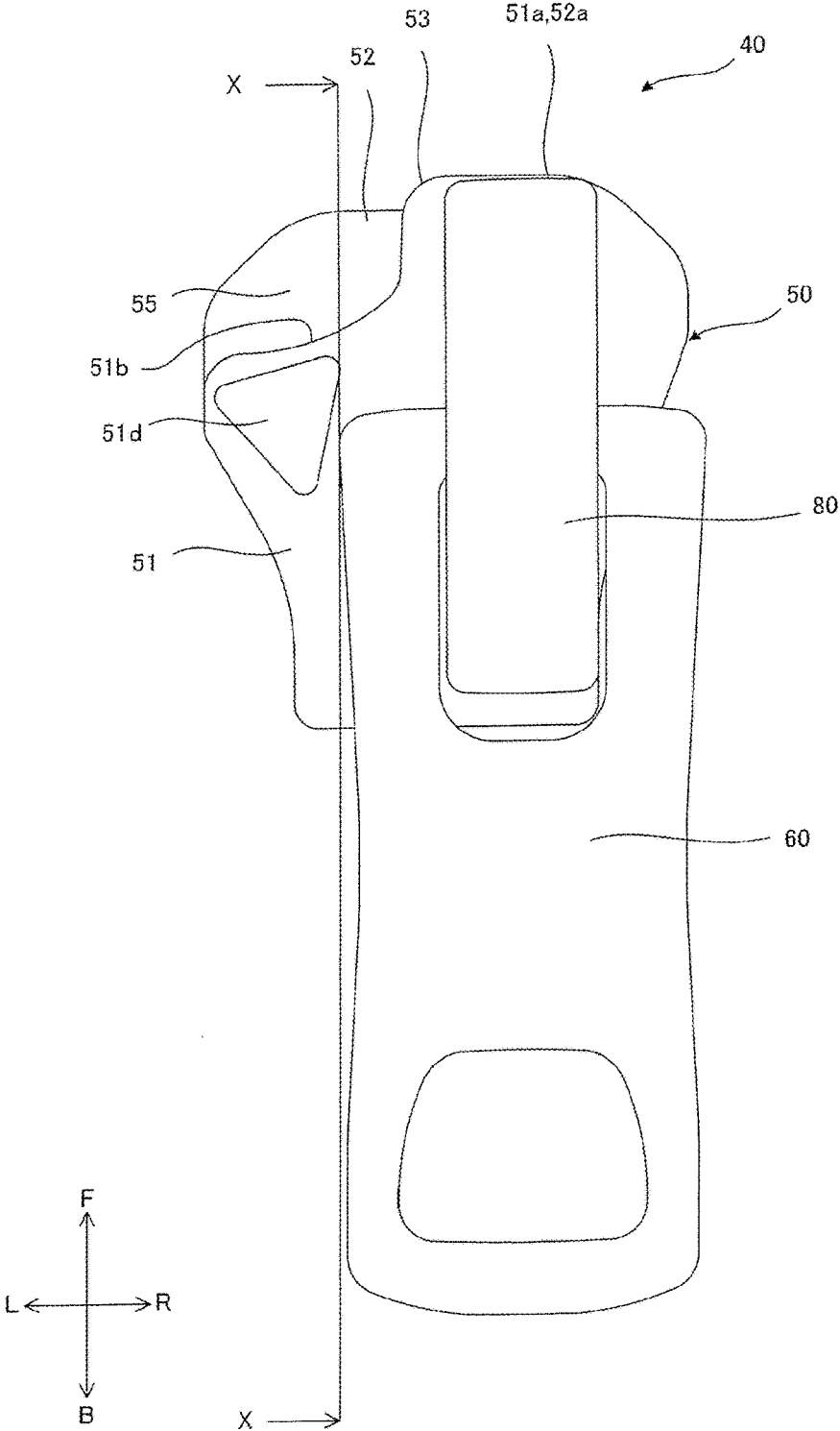

Fig. 10

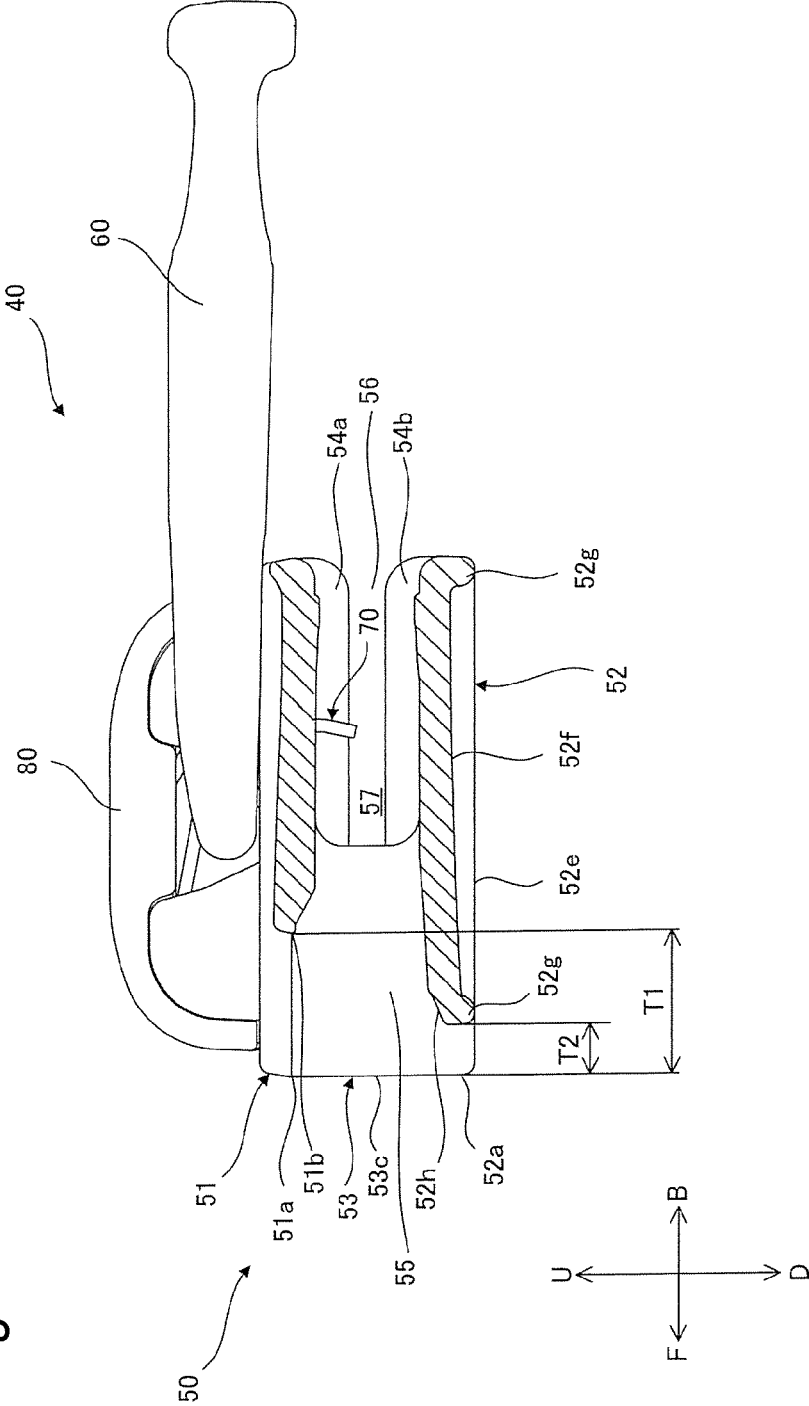

Fig. 11

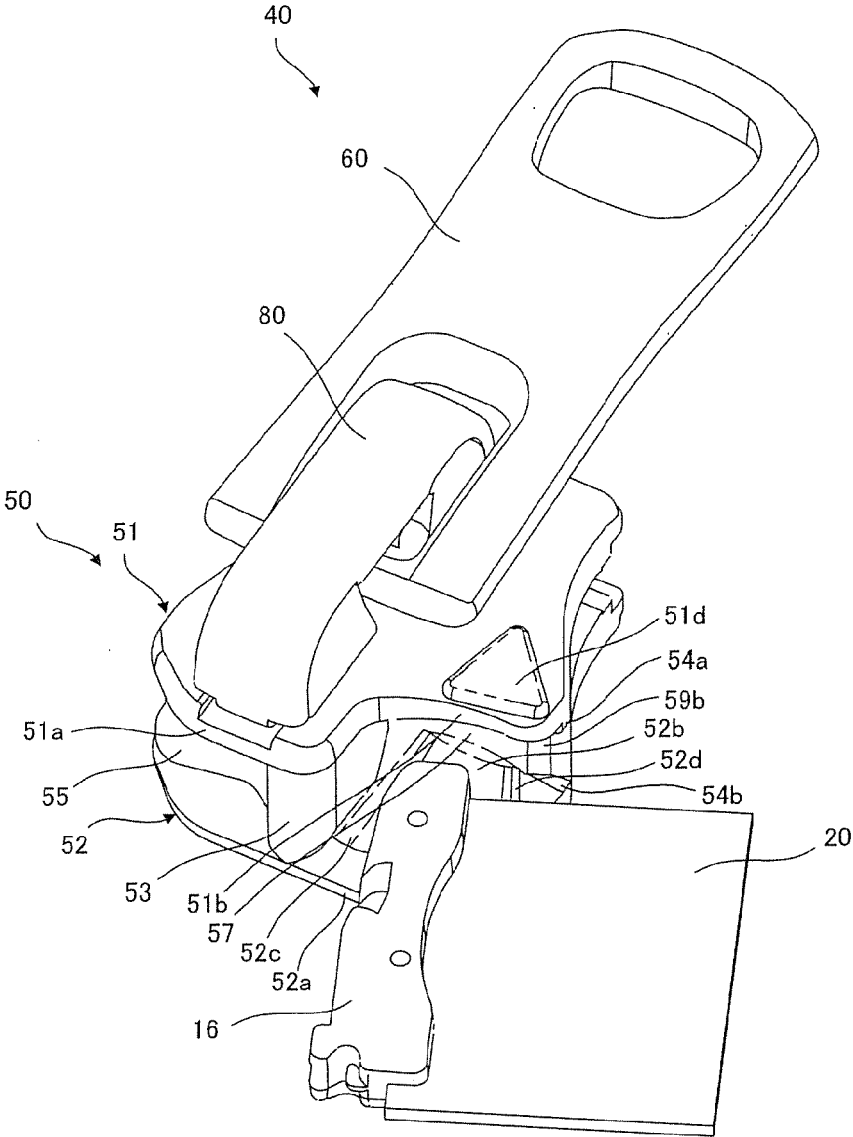
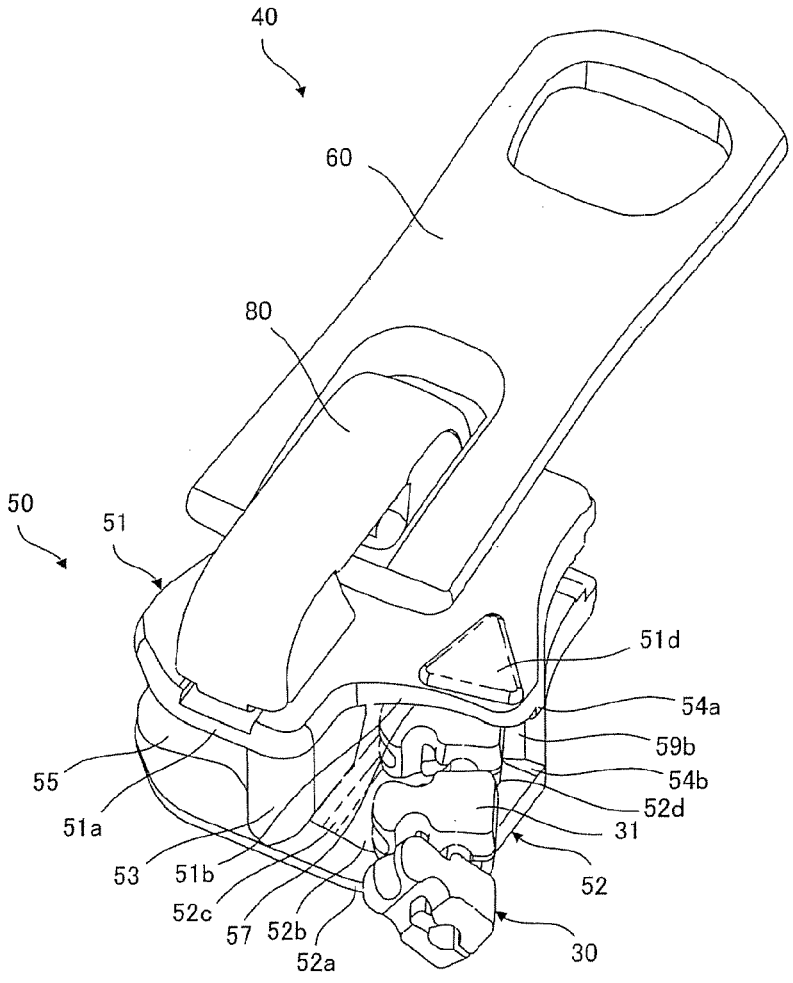

Fig. 12







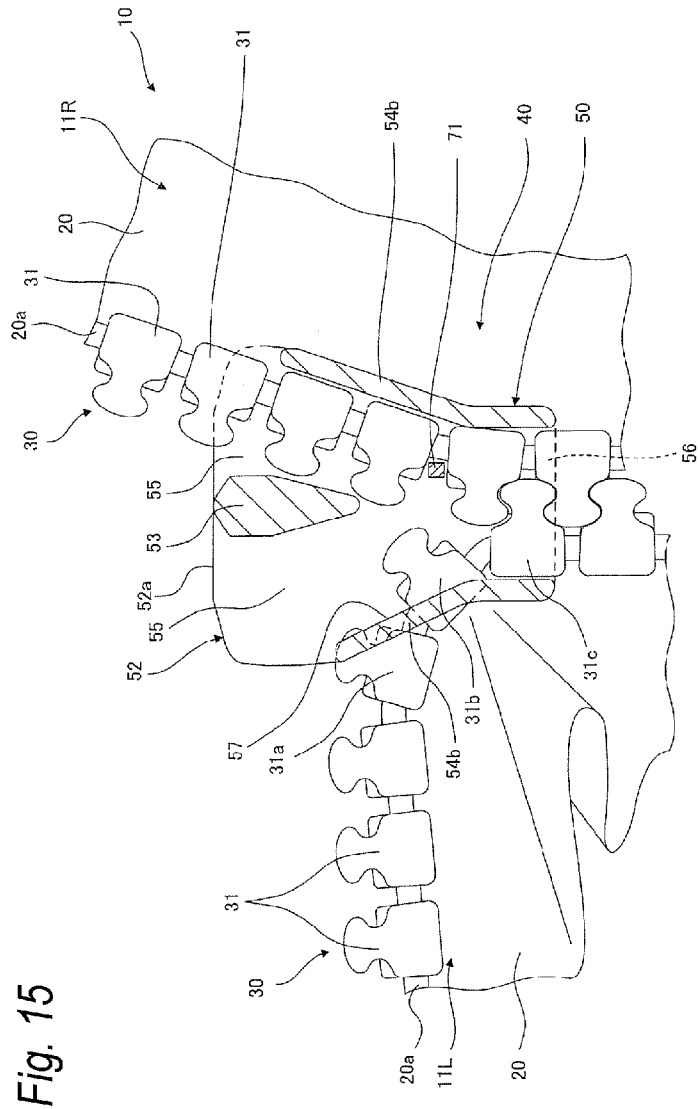

Fig. 15



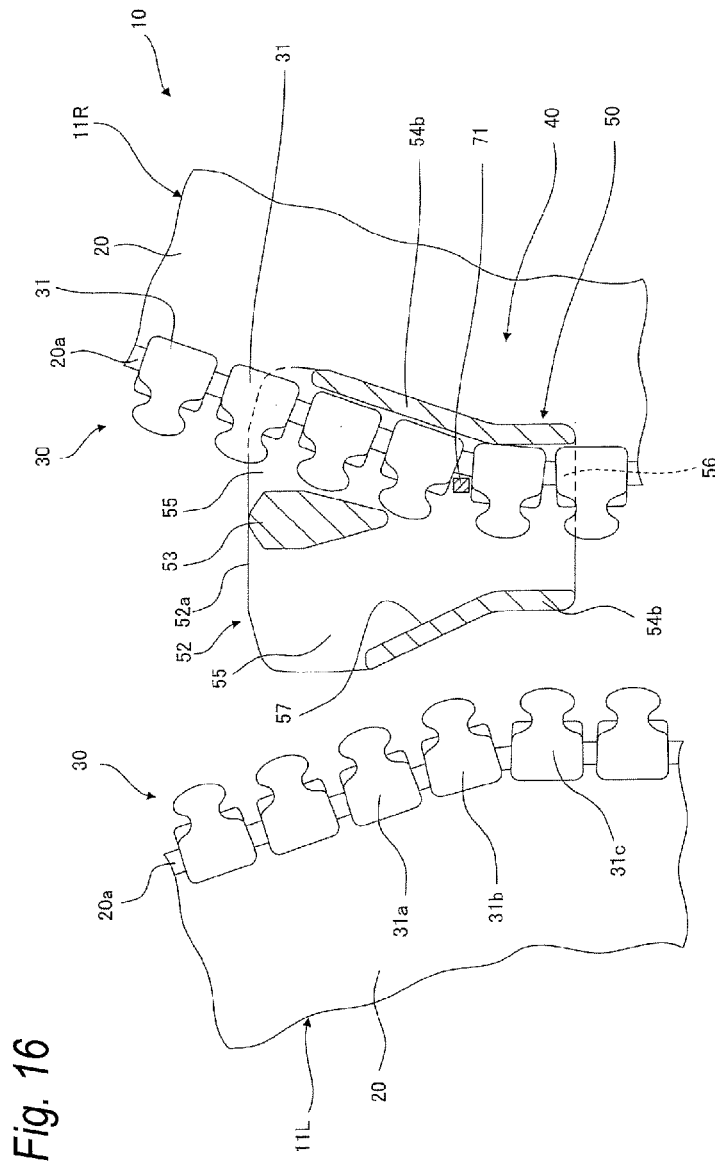

Fig. 17

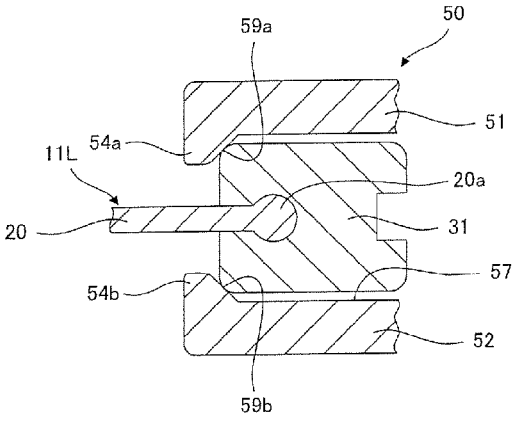

Fig. 18

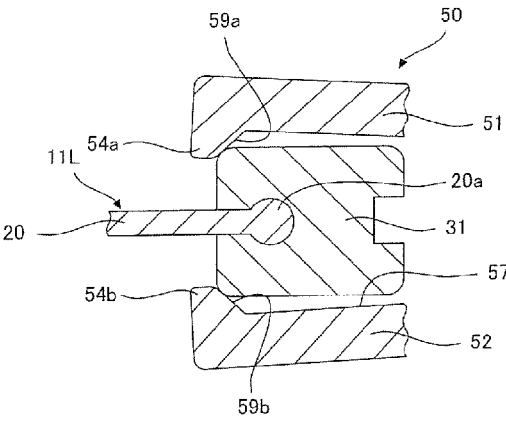
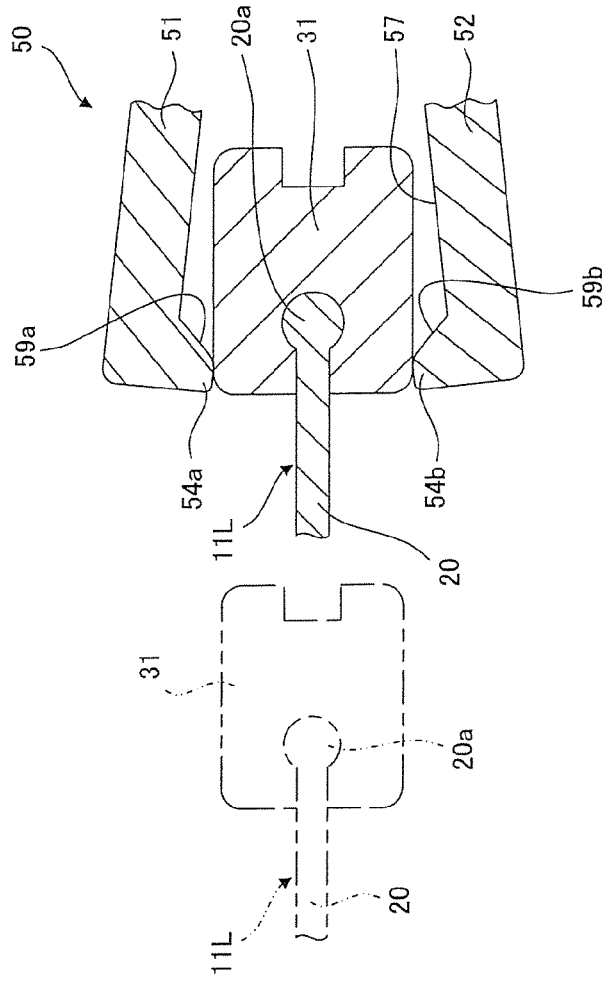

Fig. 19



**SLIDER AND SLIDE FASTENER**

## TECHNICAL FIELD

**[0001]** The present invention relates to a slider and a slide fastener, and in particular to a slider and a slide fastener, in which a separable pin and elements can be simply inserted into the slider.

## BACKGROUND ART

**[0002]** As conventional slide fasteners, a technique is known, in which a lower blade and a connecting post are configured to have an extended length in order to allow a separable pin to be simply inserted into a slider (e.g., see Patent Document 1).

## CITATION LIST

## Patent Document

**[0003]** Patent Document 1: Japanese Patent Application Publication No. 2009-273852

## SUMMARY OF INVENTION

## Problems to be Solved by Invention

**[0004]** However, the slider described in the above Patent Document 1 is increased in size and has a poor operability, since the connecting post and the lower blade have the extended length.

**[0005]** The present invention has been made keeping in mind the above problems, and an object thereof is to provide a slider and a slide fastener, in which a good operability is achieved while having a compact and simple structure and also a separable pin and elements can be simply inserted into the slider.

## Means for Solving Problems

**[0006]** A slider according to one embodiment of the present invention includes:

**[0007]** a slider body including an upper blade and a lower blade arranged to be spaced from each other in an up-down direction and to be parallel to each other, a guide post connecting the upper blade and the lower blade, and a pull attachment portion provided on the upper surface of the upper blade; and

**[0008]** a pull attached to the pull attachment portion,

**[0009]** wherein a cut-out portion (51*b*) is formed on a front end portion of the upper blade at one of left and right sides with respect to the guide post, the cut-out portion is formed to be positioned at a rear side than a front end portion of the upper blade at on the other of the left and right sides with respect to the guide post and than a front end portion of the lower blade.

**[0010]** In the slider according to one embodiment of the present invention,

**[0011]** a distance from a front end portion of the guide post to the cut-out portion of the upper blade is longer than a distance from the front end portion of the guide post to the front end portion of the lower blade.

**[0012]** In the slider according to one embodiment of the present invention,

**[0013]** the distance from the front end portion of the guide post to the front end portion of the lower blade is zero.

**[0014]** In the slider according to one embodiment of the present invention,

**[0015]** the cut-out portion is formed to extend from one lateral surface of the guide post toward the outside.

**[0016]** In the slider according to one embodiment of the present invention,

**[0017]** the upper surface of the lower blade, on the side at which the cut-out portion is formed, is provided with an inclined portion formed to be inclined upward as it goes rearward from the front end portion.

**[0018]** In the slider according to one embodiment of the present invention,

**[0019]** the upper surface of the front end portion of the lower blade, on the side at which the cut-out portion is formed, is provided with:

**[0020]** an introduction inside portion formed to be inclined upward as it goes toward the guide post;

**[0021]** an introduction outside portion formed to be inclined upward as it goes toward the outside; and

an introduction middle portion formed in a recessed shape between the introduction inside portion and the introduction outside portion.

**[0022]** In the slider according to one embodiment of the present invention,

**[0023]** the lower blade is formed such that a thickness of one of left and right parts thereof, on the side at which the cut-out portion of the upper blade is formed, is thinner than a thickness of the other of the left and right parts, on the side at which the cut-out portion of the upper blade is not formed.

**[0024]** A slide fastener according to one embodiment of the present invention includes:

**[0025]** a fastener chain in which a pair of fastener stringers including a pair of respective fastener tapes and respective element rows constituted of a plurality of elements fixed on respective tape side edge portions of the pair of fastener tapes are arranged so that the element rows are arranged to oppose each other; and

**[0026]** the slider as described above attached to be slidable along the element rows and configured to engage and disengage the elements.

**[0027]** The slide fastener according to one embodiment of the present invention further includes:

**[0028]** a top stop formed an top end of the tape side edge portion of each of the pair of fastener tapes; and

**[0029]** an opener formed on bottom ends of a tape side edge portions of the pair of fastener tapes.

## Advantageous Effects of Invention

**[0030]** According to the slider and the slide fastener of one embodiment of the present invention, on the part of the upper blade, which is located on one of left and right sides with the guide post, the cut-out portion is formed to be positioned in the rear of a front end portion of the part of the upper blade, which is located on the other of the left and right sides with the guide post, and also the front end portion of the lower blade. Accordingly, an insertion position of the separable pin can be easily seen and also the lower blade can guide the separable pin and the elements. Therefore, in the slider and the slide fastener of one embodiment of the present invention, a good operability is achieved while having a compact and simple structure and also a separable pin and elements can be simply inserted into the slider.

## BRIEF DESCRIPTION OF DRAWINGS

[0031] FIG. 1 shows a slide fastener according to the present embodiment.

[0032] FIG. 2 shows a perspective view of a slider according to the present embodiment.

[0033] FIG. 3 shows a plan view of a slider according to the present embodiment.

[0034] FIG. 4 shows a rear view of the slider according to the present embodiment as viewed from a rear mouth side thereof.

[0035] FIG. 5 shows a sectional view taken along a V-V line in FIG. 3.

[0036] FIG. 6 shows a sectional view taken along a VI-VI line in FIG. 3.

[0037] FIG. 7 shows a sectional view taken along a VII-VII line in FIG. 3.

[0038] FIG. 8 shows an enlarged front surface view of the slide fastener in a state where an upper blade of the slider according to the present embodiment is partially cut out.

[0039] FIG. 9 shows a plan view of a slider according to another embodiment.

[0040] FIG. 10 shows a sectional view taken along an X-X line in FIG. 9.

[0041] FIG. 11 shows a state where a separable pin is being inserted into the slider according to the present embodiment.

[0042] FIG. 12 shows a state where an element is being inserted into the slider according to the present embodiment.

[0043] FIG. 13 shows an enlarged front surface view explaining a state where a crosswise force is exerted on the slide fastener shown in FIG. 8.

[0044] FIG. 14 shows an enlarged front surface view explaining a state where an element of a separable fastener stringer shown in FIG. 13 begins being removed out of the slider.

[0045] FIG. 15 shows an enlarged front surface view explaining a state where the element shown in FIG. 14 is further removed out of the slider.

[0046] FIG. 16 shows an enlarged front surface view explaining a state where the element shown in FIG. 15 is completely removed out of the slider.

[0047] FIG. 17 shows a partial sectional view explaining a state where the element of the separable fastener stringer is in contact with flanges of the slider.

[0048] FIG. 18 shows a partial sectional view explaining a state where the element of the separable fastener stringer is pushing and spreading out flanges of the slider.

[0049] FIG. 19 shows a partial sectional view explaining a state where the element shown in FIG. 14 forces the upper blade and the lower blade to be bent and thus is being removed out of the slider.

## DESCRIPTION OF EMBODIMENTS

[0050] Hereinafter, a slider 40 and a slide fastener 10 according to one embodiment of the present invention will be described in detail with reference to the accompanying drawings.

[0051] FIG. 1 shows a slide fastener according to the present embodiment. FIG. 2 shows a perspective view of a slider according to the present embodiment. FIG. 3 shows a plan view of a slider according to the present embodiment. FIG. 4 shows a rear view of the slider according to the present embodiment as viewed from a rear mouth side

thereof. FIG. 5 shows a sectional view taken along a V-V line in FIG. 3. FIG. 6 shows a sectional view taken along a VI-VI line in FIG. 3. FIG. 7 shows a sectional view taken along a VII-VII line in FIG. 3. FIG. 8 shows an enlarged surface view of the slide fastener in a state where an upper blade of the slider according to the present embodiment is partially cut out. FIG. 9 shows a plan view of a slider according to another embodiment. FIG. 10 is a sectional view taken along an X-X line in FIG. 9.

[0052] Meanwhile, in a slide fastener 10 of the present embodiment, a lengthwise direction of a fastener tape 2 is referred to as a front-rear direction (F-B direction) and is represented by arrows F (forward direction) and R (rearward direction). Also, a widthwise direction of the fastener tape 2 is referred to as a left-right direction (L-R direction) and is represented by arrows L (left direction) and R (right direction). Further, a front and back direction of the fastener tape 2 is referred to as an up-down direction (U-D direction) and is represented by arrows U (upward direction) and D (downward direction). In addition, it should be noted that directions in the slider 40 itself is based on directions in the slide fastener 10 when the slider 40 is attached on the slide fastener 10.

[0053] That is, an upper side refers to a front side with respect to the paper surface of FIG. 1; a lower side refers to a back side with respect to the paper surface of FIG. 1; a front side refers to an upper side with respect to the paper surface of FIG. 1; a rear side refers to a lower side with respect to the paper surface of FIG. 1; a left side refers to a left side with respect to the paper surface of FIG. 1; and a right side refers to a right side with respect to the paper surface of FIG. 1.

[0054] Further, the left-right direction of the fastener tape 2 is also referred to as the widthwise direction. Also, the up-down direction of the fastener tape 2 is also referred to as the lengthwise direction.

[0055] As shown in FIGS. 1 and 8, the slide fastener 10 of the present embodiment includes a fastener chain 11 constituted of a pair of fastener stringers 11L, 11R, which have a pair of respective fastener tapes 20 and respective element rows 30 each constituted of a plurality of elements 31 fixed on respective edge portions 20a of the pair of fastener tapes 20 at predetermined pitches, and in which the element rows 30 are arranged to oppose each other; a slider 40 attached to be slidable along the fastener element rows 30 and configured to engage and disengage the fastener elements 31; a top stop 12 formed on top end of a tape side edge portion 20a of each of the pair of left and right fastener tapes 20; and an opener 13 formed on bottom ends of a tape side edge portions 20a of the pair of left and right fastener tapes 20.

[0056] The opener 13 includes a retainer pin 14 and a box body 15 formed on the top end of the tape side edge portion 20a of the right fastener tape 20, and a separable pin 16 formed on the bottom end of the tape side edge portion 20a of the left fastener tape 20 and capable of being inserted in the box body 15. Further, in the present embodiment, the left fastener stringer 11L provided with the separable pin 16 is a separable fastener stringer which can be separated from the slider 40, and the right fastener stringer 11R provided with the retainer pin 14 and the box body 15 is a fixed fastener stringer, which cannot be separated from the slider 40. Alternatively, the left and right arrangement of the retainer pin 14, and the box body 15 and separable pin 16 may be reversed.

[0057] Each of the fastener element rows 30 is constituted of a plurality of fastener elements 31, and the fastener elements 31 are injection-molded on the tape side edge portion 20a of the respective fastener tapes 20 using synthetic resin, such as polyamide, polyacetal, polypropylene or polybutylene terephthalate.

[0058] As shown in FIGS. 2 to 8, the slider 40 is a slider having an automatic stop function and includes a slider body 50, a pull 60, a stop claw body 70 and a pull holding cover 80.

[0059] The slider body 50 includes an upper blade 51 and a lower blade 52 arranged to be spaced from each other in the up-down direction and to be parallel to each other; a guide post 53 connecting front end portions of the upper blade 51 and the lower blade 52 at an introduction middle portion; upper flanges 54a protruding downward from left and right side edges of the upper blade 51; and lower flanges 54b protruding upward from left and right side edges of the lower blade 52. Accordingly, left and right shoulder mouths 55, which are separated from each other by the guide post 53, are formed in a front portion of the slider body 50, and a rear mouth 56 is formed in a rear portion of the slider body 50. Also, an element guide passage 57 having a generally Y-shape is formed between the upper blade 51 and the lower blade 52 to communicate the left and right shoulder mouths 55 with the rear mouth 56. The element guide passage 57 forms a passage allowing the pair of left and right fastener element rows 30 to be inserted therethrough.

[0060] Further, as shown in FIG. 4, a dimension S1, in the up-down direction, of a gap between the left upper and lower flanges 54a, 54b of the slider body 50 is set to be greater than a dimension S2, in the up-down direction, of a gap between the right upper and lower flanges 54a, 54b. Thus, when a crosswise force is exerted on the pair of left and right fastener stringers 11L, 11R, the left fastener stringer 11L can be separated from the slider 40.

[0061] Further, as shown in FIG. 5, on a part of an upper surface of the upper blade 51, which is located on a right side with respect to the guide post 53 (on the side of the fixed fastener stringer 11R), a front attaching post 58F and a rear attaching post 58B configured to allow a pull holding cover 80 to be attached thereto are erected side by side in the front-rear direction. More specifically, as shown in FIG. 8, the guide post 53 has a left lateral surface (front lateral surface 53a and rear lateral surface 53b) and a right lateral surface, and the front attaching post 58F and the rear attaching post 58B are erected on the part of the upper surface of the upper blade 51, which is located on the right side with respect to the left lateral surface of the guide post 53. In addition, a link portion 61 of the pull 60 and the stop claw body 70 are received between the front attaching post 58F and the rear attaching post 58B, and the pull holding cover 80 is covered on the front attaching post 58F and the rear attaching post 58B and also fixed thereto by crimping. Further, in the upper blade 51, a claw insertion hole 51c is formed to allow a stop claw 71 of the stop claw body 70 to be inserted therein. Meanwhile, in the present embodiment, the front attaching post 58F, the rear attaching post 58B, the stop claw body 70 and the pull holding cover 80 constitute a pull attachment portion.

[0062] Also, as described above, since the front attaching post 58F and the rear attaching post 58B are formed on the part of the upper blade 51, which is located on the right side with respect to the guide post 53, a part of the upper blade

51, which is located on the left side with respect to the guide post 53, has a slightly reduced rigidity and thus is configured to be easily bent. Since the left part of the upper blade 51 is bent, the separable fastener stringer 11L can be separated from the slider 40.

[0063] Further, in addition to the front attaching post 58F and the rear attaching post 58B, the stop claw body 70 is also arranged on the part of the upper blade 51, which is located on the right side with respect to the guide post 53. Accordingly, as shown in FIG. 8, the stop claw 71 of the stop claw body 70 is inserted between fastener elements 31 of the fixed fastener stringer 11R. Therefore, contact between the stop claw 71 and the fastener elements 31 of the separable fastener stringer 11L is prevented, thereby allowing the separable fastener stringer 11L to be separated from the slider 40.

[0064] However, although the slider 40 having an automatic stop function is illustrated in the present embodiment, the present invention is not limited thereto. A slider 40 having an automatic stop function, in which a pull attaching post configured to allow the pull 60 to be attached thereto is erected to replace the front attaching post 58F and the rear attaching post 58B, may be employed.

[0065] Further, as shown in FIGS. 2 and 3, the upper blade 51 has a cut-out portion 51b formed to extend from the left front lateral surface 53a of the guide post 53 toward the outside (toward the separable fastener stringer 11L). Also, the cut-out portion 51b is formed to be inclined rearward as it goes from the left front lateral surface 53a of the guide post 53 toward the outside. More specifically, as shown in FIG. 8, the guide post 53 has a front end portion 53c, a rear end portion 53d, the left lateral surface (front lateral surface 53a and rear lateral surface 53b) and the right lateral surface, and the cut-out portion 51b is formed to extend between the front end portion 53c and the rear end portion 53d of the guide post 53 and also from the left lateral surface of the guide post 53 outwardly. Thus, as shown in FIGS. 7 and 10, the cut-out portion 51b of the upper blade 51 on the left side of the guide post 53 is positioned in the rear of the front end portion 52a of the lower blade 52. Also, the cut-out portion 51b of the upper blade 51 on the left side of the guide post 53 is positioned in the rear of a front end portion 51a of the part of the upper blade 51, which is located on the right side with respect to the guide post 53. Further, a distance T1 from the front end portion 53c of the guide post 53 to the cut-out portion 51b of the upper blade 51 is longer than a distance T2 from the front end portion 53c of the guide post 53 to the front end portion 52a of the lower blade 52. Meanwhile, in the slider 40 of the present embodiment, the distance T1 from the front end portion 53c of the guide post 53 to the cut-out portion 51b of the upper blade 51 is about 1/4 to 1/3 of a distance from the front end portion 53c of the guide post 53 to the rear end of the slider 40.

[0066] Due to this configuration, according to the slider 40 and the slide fastener 10 of the present embodiment, parts of the upper blade and the lower blade, which are located on one side in the widthwise direction with respect to the guide post, can be easily bent and also an insertion position of the separable pin can be easily seen. Further, since the cut-out portion 51b is formed on a front end portion of a part of the upper blade 51, which is located on one of left and right sides with respect to the guide post 53, a region, on which the front attaching post 58F and the rear attaching post 58B can be erected, can be set aside on a part of the upper blade

**51**, which is located on the other of the left and right sides with respect to the guide post **53**. Further, when a crosswise force is exerted on the pair of left and right fastener stringers **11L**, **11R**, the part of the upper blade **51**, which is located on the one of the left and right sides with respect to the guide post **53** and on which the cut-out portion **51b** is formed, is more easily bent than the part of the upper blade **51**, which is located on the other of the left and right sides with respect to the guide post **53** and on which the cut-out portion **51b** is not formed. Therefore, it is possible to achieve a good operability while having a compact and simple structure. Also, when a crosswise force is exerted on the pair of left and right fastener stringers **11L**, **11R**, one fastener stringer **11L** can be easily separated from the slider **40**. In addition, the separable pin **16** and the elements **31** can be simply inserted into the slider **40**.

[0067] On the other hand, a left part of the front end portion **52a** of the lower blade **52** is formed to be flush with a right part of the front end portion **52a** of the lower blade **52** as shown in FIG. 3, or is formed in the rear of the front end portion **53c** of the guide post **53** in order to satisfy  $T1 > T2$  as shown in FIG. 9.

[0068] Due to this configuration, according to the slider **40** and the slide fastener **10** of the present embodiment, the insertion position of the separable pin **16** can be more easily seen. Thus, the separable pin **16** and the elements **31** can be more simply inserted into the slider **40**.

[0069] Further, the left part of the front end portion **52a** of the lower blade **52** may be positioned at the same or substantially the same position as that of the front end portion **53c** of the guide post **53** in the front-rear direction (F-B direction). That is, the distance **T2** from the front end portion **53c** of the guide post **53** to the front end portion **52a** of the lower blade **52** may be zero. Further, the front end portion **52a** of the lower blade **52** may be positioned at the same or substantially the same position as that of the front end portion **51a** of the right part of the upper blade **51** in the front-rear direction (F-B direction).

[0070] Due to this configuration, according to the slider **40** and the slide fastener **10** of the present embodiment, it is possible to achieve a good operability while having a more compact and simple structure.

[0071] Also, as shown in FIG. 8, a distance **L1** between the rear end portion **53d** of the guide post **53** and a front end portion **54c** of the left upper and lower flanges **54a**, **54b** of the slider body **50** in the front-rear direction is shorter than a distance **L2** between the rear end portion **53d** of the guide post **53** and the front end portion **54c** of the right upper and lower flanges **54a**, **54b** of the slider body **50** in the front-rear direction. Further, a distance **L3** between the front end portion **53c** of the guide post **53** and the front end portion **54c** of the left upper and lower flanges **54a**, **54b** in the front-rear direction is longer than the distance **T1** from the front end portion **53c** of the guide post **53** to the cut-out portion **51b** of the upper blade **51**.

[0072] Also, as shown in FIGS. 2 and 4, the cut-out portion **51b** is formed to extend from generally the middle of the left rear lateral surface **53b** of the guide post **53** outwardly in the widthwise direction. Further, inside surfaces, in the widthwise direction, of the left upper and lower flanges **54a**, **54b** of the slider body **50** are respectively formed by inclined surfaces **59a**, **59b**, of which thickness is gradually increased toward the outside.

[0073] As shown in FIG. 3, an insertion direction indicator portion **51d** is formed on an upper surface of the left part of the upper blade **51**. By forming the insertion direction indicator portion **51d**, a direction of the separable pin **16** when being inserted into the slider **40** can be easily identified. In the present embodiment, the insertion direction guide portion **51d** is formed to protrude from the upper surface. Since the insertion direction indicator portion **51d** is formed to protrude from the upper surface, it is possible to prevent adhesion with another slider **40** upon manufacturing. Also, the insertion direction indicator portion **51d** of the present embodiment is formed in a triangular shape so that an apex thereof is oriented toward the rear mouth, thereby indicating the insertion direction of the separable pin **16**. Alternatively, any other shapes, such as a rounded shape or a quadrangular shape, may be employed.

[0074] Further, as shown in FIG. 6, the lower blade **52** has an introduction middle portion **52b** formed on a part thereof, which defines the shoulder mouths **55**, to have a recessed shape between an introduction inside portion **52c** and an introduction outside portion **52d**. That is, since the introduction inside portion **52c** is formed to be inclined upward as it goes from the introduction middle portion **52b** toward the guide post **53** and the introduction outside portion **52d** is formed to be inclined upward as it goes from the introduction middle portion **52b** toward the outside, the introduction middle portion **52b** is formed at a location below the introduction inside portion **52c** and the introduction outside portion **52d** on both sides thereof. In addition, as shown in FIG. 7, on a part ranging from the front end portion **52a** to the introduction middle portion **52b**, introduction inside portion **52c** and introduction outside portion **52d**, an inclined portion **52h** is formed to be gradually inclined upward toward the rear side. Also, a part of the lower blade **52**, which is located on a left side with respect to the guide post **53**, is formed such that a thickness of a front side thereof is thinner than a thickness of a rear side thereof and also a front end thereof is thinnest.

[0075] Therefore, according to the slider **40** of the present embodiment, it is possible to guide the separable pin **16** and the elements **31** to the element guide passage **57**, thereby allowing the separable pin **16** and the elements **31** to be more simply inserted therein.

[0076] Also, as shown in FIGS. 6 and 7, the lower blade **52** is formed such that a thickness of one of left and right parts thereof, on the side of which the cut-out portion **51b** of the upper blade **51** is formed, is thinner than a thickness of the other of the left and right parts, on the side of which the cut-out portion **51b** of the upper blade **51** is not formed. Further, protrusions **52g** are formed to protrude downward from top and bottom end portions and a left end portion of a lower surface **52** of the lower blade **52**. As a result, a recess portion **52f** is formed on the lower surface **52e** of one of the left and right parts of the lower blade **52**, on the side of which the cut-out portion **51b** of the upper blade **51** is formed.

[0077] Also, according to the slider **40** of the present embodiment, a part of the lower blade **52**, which is located on one side in the widthwise direction with respect to the guide post **53**, can be configured to be more easily bent, since a thickness of one of the left and right parts of the lower blade **52**, on the side of which the cut-out portion **51b** of the upper blade **51** is formed, is thinner than a thickness of the other of the left and right parts, on the side of which

the cut-out portion **51b** of the upper blade **51** is not formed. Therefore, it is possible to separate one fastener stringer **11L** from the slider **40**.

[0078] Further, according to the slider **40** of the present embodiment, it is possible to prevent adhesion with another slider **40** upon manufacturing thereof, since the protrusions **52g** are formed. In addition, by forming the protrusions **52g** to have a rounded surface, an edge is not formed on the end portions, thereby preventing contact with the edge.

[0079] Next, an operation of the slide fastener **10** using the slider **40** of the present embodiment as described above will be described.

[0080] In the following, a state where the separable pin **16** is being inserted into the slider **40** will be described.

[0081] FIG. **11** shows a state where the separable pin **16** is being inserted into the slider **40** according to the present embodiment.

[0082] In the slide fastener **10** of the present embodiment, the separable pin **16** is inserted into the element guide passage **57** while being guided by the lower blade **52**, when the separable pin **16** is inserted into the slider **40**. At this time, if the separable pin **16** abuts against the lower blade **52** of the slider **40**, the separable pin **16** is smoothly inserted into the element guide passage **57**.

[0083] Since the cut-out portion **51b** is formed on the upper blade **51** of the slider **40**, the shoulder mouth **55** allowing the separable pin **16** to be inserted into the element guide passage **57** is widened as compared with a case where the cut-out portion **51b** is not formed. In the case where the cut-out portion **51b** is not formed, it is necessary to accurately insert the separable pin **16** into the shoulder mouth **55** from the front side thereof toward the rear side. In the case where the cut-out portion **51b** is formed, it is possible to insert the separable pin **16** into the shoulder mouth **55** simply by operating the separable pin **16** to be placed on the lower blade **52** from upper and left sides thereof as well as the front side. Also, since the cut-out portion **51b** is formed to be inclined rearward as it goes from the left front lateral surface **53a** of the guide post **53** toward the outside, it is possible to form the shoulder mouth **55** as wide as possible while maintaining strength of the cut-out portion **51b**. Further, since the cut-out portion **51b** is formed in the rear of the front end of the front attaching post **58F**, it is possible to add an insertion assist function to the slider without increasing a size of the slider, but while maintaining a function thereof as a slider. That is, the separable pin **16** is guided by the lower blade **52** and thus is smoothly inserted into the element guide passage **57**.

[0084] Also, the lower blade **52** is formed such that the introduction middle portion **52b** on the part thereof, which defines the shoulder mouths **55**, is formed to have a recessed shape between the introduction inside portion **52c** and the introduction outside portion **52d**. Accordingly, the separable pin **16** can naturally approach the introduction middle portion **52b**, so that the separable pin **16** is more smoothly inserted into the element guide passage **57**.

[0085] Further, as shown in FIGS. **2** and **4**, introduction inside portions on the left upper and lower flanges **54a**, **54b** of the slider body **50** are respectively formed by the inclined surfaces **59a**, **59b**, of which thickness is gradually increased from the introduction inside portions toward the outside. Accordingly, the separable pin **16** can be guided to the inside, so that the separable pin **16** is more smoothly inserted into the element guide passage **57**.

[0086] Further, the front attaching post **58F**, the rear attaching post **58B** and the stop claw body **70** as shown in FIG. **5** are arranged on the part of the upper blade **51**, which is located on the right side with respect to the guide post **53**. Accordingly, the shoulder mouth **55** allowing the separable pin **16** to be inserted into the element guide passage **57** is widened. That is, the separable pin **16** is guided by the lower blade **52** and thus is smoothly inserted into the element guide passage **57**. In addition, visibility of the insertion direction indicator portion **51d** formed on the upper surface of the left part of the upper blade **51** can be improved.

[0087] Subsequently, a state where an element **31** is being inserted into the slider **40** will be described.

[0088] FIG. **12** shows a state where an element **31** is being inserted into the slider **40** according to the present embodiment.

[0089] In the slide fastener **10** of the present embodiment, the element **31** is inserted into the element guide passage **57** while being guided by the lower blade **52**, when the element **31** is inserted into the slider **40**. At this time, if the element **31** abuts against the lower blade **52** of the slider **40**, the element **31** is turned in a direction allowing the element **31** to be naturally inserted into the element guide passage **57**, so that the element **31** is smoothly inserted into the element guide passage **57**.

[0090] Since the cut-out portion **51b** is formed on the upper blade **51** of the slider **40**, the shoulder mouth **55** allowing the element **31** to be inserted into the element guide passage **57** is widened as compared with the case where the cut-out portion **51b** is not formed. That is, the element **31** is guided by the lower blade **52** and thus is smoothly inserted into the element guide passage **57**.

[0091] Also, the lower blade **52** is formed such that the introduction middle portion **52b** on the part thereof, which defines the shoulder mouths **55**, is formed to have a recessed shape between the introduction inside portion **52c** and the introduction outside portion **52d**. Accordingly, the element **31** can naturally approach the introduction middle portion **52b**, so that the element **31** is more smoothly inserted into the element guide passage **57**.

[0092] Further, as shown in FIGS. **2** and **4**, the introduction inside portions on the left upper and lower flanges **54a**, **54b** of the slider body **50** are respectively formed by the inclined surfaces **59a**, **59b**, of which thickness is gradually increased from the introduction inside portions toward the outside. Accordingly, the element **31** can be guided to the inside, so that the element **31** is more smoothly inserted into the element guide passage **57**.

[0093] Further, the front attaching post **58F**, the rear attaching post **58B** and the stop claw body **70** as shown in FIG. **5** are arranged on the part of the upper blade **51**, which is located on the right side with respect to the guide post **53**. Accordingly, the shoulder mouth **55** allowing the element **31** to be inserted into the element guide passage **57** is widened. That is, the element **31** is guided by the lower blade **52** and thus is easily inserted into the element guide passage **57**. In addition, visibility of the insertion direction indicator portion **51d** formed on the upper surface of the left part of the upper blade **51** can be improved.

[0094] Subsequently, a state where the separable fastener stringer **11L** is being separated from the slider **40** will be described.

[0095] FIG. **13** shows an enlarged front surface view explaining a state where a crosswise force is exerted on the



slide fastener 10 shown in FIG. 8. FIG. 14 shows an enlarged front surface view explaining a state where an element 31 of the separable fastener stringer 11L shown in FIG. 13 begins being removed out of the slider 40. FIG. 15 shows an enlarged front surface view explaining a state where the element 31 shown in FIG. 14 is further removed out of the slider 40. FIG. 16 shows an enlarged front surface view explaining a state where the element 31 shown in FIG. 15 is completely removed out of the slider 40. FIG. 17 shows a partial sectional view explaining a state where the element 31 of the separable fastener stringer 11L is in contact with the flanges 54a, 54b of the slide 40. FIG. 18 shows a partial sectional view explaining a state where the element 31 of the separable fastener stringer 11L is pushing and spreading out the flanges 54a, 54b of the slide 40. FIG. 19 is a partial sectional view explaining a state where the element 31 shown in FIG. 14 forces the upper blade 51 and the lower blade 52 to be bent and thus is being removed out of the slider 40.

[0096] If a crosswise force is exerted on the slide fastener 10 shown in FIG. 8, elements 31 of the left element group 30, which do not abut against the upper and lower flanges 54a, 54b, are pulled out in the left direction as shown in FIG. 13. Meanwhile, as shown in FIGS. 2 and 4, the introduction inside portions on the left upper and lower flanges 54a, 54b of the slider body 50 are respectively formed by the inclined surfaces 59a, 59b, of which thickness is gradually increased from the introduction inside portions toward the outside. Accordingly, as shown in FIG. 17, upper and lower corner portions of a fastener element 31 of the separable fastener stringer 11L, on which the crosswise force is exerted, abut respectively against the inclined surfaces 59a, 59b of the upper and lower flanges 54a, 54b. Then, the crosswise force is effectively transferred to the upper blade 51 and the lower blade 52 via the inclined surfaces 59a, 59b.

[0097] Therefore, as shown in FIG. 18, a gap between the upper and lower flanges 54a, 54b in the slide fastener 10 is spread out. Then, a crosswise force toward the introduction outside portion is further exerted on the pair of left and right fastener stringer 11L, 11R. Accordingly, as shown in FIGS. 14 and 19, a first fastener element 31a (fastener element 31) of the separable fastener stringer 11L, which is positioned within the element guide passage 57 to be closest to the shoulder mouth 55 and is not engaged, is removed out of the slider 40 by forcing the parts of the upper and lower blades 51, 52, which are located on the left side with respect to the guide post 53, to be bent.

[0098] Then, as shown in FIG. 15, subsequently to the first fastener element 31a, second and third fastener elements 31b, 31c are also sequentially removed out of the slider 40 in the same manner as that in the first fastener element 31a. Therefore, as shown in FIG. 16, the separable fastener stringer 11L is separated from the slider 40.

[0099] As described above, in the slider 40 of the present embodiment, a length, in the front-rear direction, of the left upper and lower flanges 54a, 54b of the slider body 50 is shorter than those of the right upper and lower flanges 54a, 54b of the slider body 50. Accordingly, the parts of the upper and lower blades 51, 52, which are located on the left side with respect to the guide post 53, have a slightly reduced rigidity and thus are configured to be easily bent. Therefore, it is possible to allow the left parts of the upper blade 51 and

the lower blade 52 to be easily bent, thereby facilitating separating the separable fastener stringer 11L from the slider 40.

[0100] Further, according to the slide fastener 10 of the present embodiment, the cut-out portion 51b extending from the left front lateral surface 53a of the guide post 53 toward the introduction outside portion is formed on the upper blade 51. Accordingly, the part of the upper blade 51, which is located on the left side with respect to the guide post 53, can be configured to be easily bent. Therefore, it is possible to facilitate separating the separable fastener stringer 11L from the slider 40 by a simple structure.

[0101] Further, as shown in FIGS. 6 and 7, the lower blade 52 is formed such that a thickness of one of the left and right parts thereof, on the side of which the cut-out portion 51b of the upper blade 51 is formed, is thinner than a thickness of the other of the left and right parts, on the side of which the cut-out portion 51b of the upper blade 51 is not formed. Accordingly, the part of the lower blade 52, which is located on one side in the widthwise direction with respect to the guide post 53, is configured to be easily bent, thereby allowing the elements 31 to be easily removed through between the upper and lower flanges 54a, 54b.

[0102] Further, the protrusions 52g are formed to protrude downward from the top and bottom end portions and the left end portion of the lower surface 52 of the lower blade 52. Therefore, even if the lower blade 52 is formed to be thin, strength thereof can be maintained. In addition, since the protrusions 52g are formed, it is possible to prevent adhesion with another slider 40 upon manufacturing.

[0103] As set forth above, the slider 40 of the present embodiment includes a slider body 50 including an upper blade 51 and a lower blade 52 arranged to be spaced from each other in the up-down direction and also to be parallel to each other; a guide post 53 connecting the upper blade 51 and the lower blade 52; and a pull attachment portion 58F, 58R, 70, 80 provided on the upper surface of the upper blade 51; and a pull 60 attached to the pull attachment portion, wherein on a front end portion of a part of the upper blade 51, which is located on one of left and right sides with the guide post 53, a cut-out portion 51b is formed to be positioned in the rear of a front end portion 51a of a part of the upper blade 51, which is located on the other of the left and right sides with the guide post 53, and also a front end portion 52a of the lower blade 52. Thus, according to the slider 40 of the present embodiment, the insertion position of the separable pin 16 can be easily seen and also the lower blade 52 can guide the separable pin 16 and the elements 31. Therefore, the slider 40 according to the present embodiment can achieve a good operability while having a compact and simple structure and also allow the separable pin 16 and the elements 31 to be simply inserted into the slider 40.

[0104] Also, in the slider 40 of the present embodiment, a distance T1 from a front end portion 53c of the guide post 53 to the cut-out portion 51b of the upper blade 51 is longer than a distance T2 from the front end portion 53c of the guide post 53 to the front end portion 52a of the lower blade 52. Thus, according to the slider 40 of the present embodiment, the insertion position of the separable pin 16 can be more easily seen and thus the separable pin 16 and the elements 31 can be simply inserted into the slider 40.

[0105] Further, in the slider 40 of the present embodiment, the distance T2 from the front end portion 53c of the guide post 53 to the front end portion 52a of the lower blade 52 is

zero. Thus, according to the slider **40** of the present embodiment, it is possible to achieve a good operability while having a more compact and simple structure.

[0106] Further, in the slider **40** of the present embodiment, the cut-out portion **51b** is formed to extend from one lateral surface **53a** of the guide post **53** toward the outside. Thus, according to the slider **40** of the present embodiment, the slider **40** can be simply manufactured.

[0107] Further, in the slider **40** of the present embodiment, an upper surface of a part of the lower blade **52**, on the side of which the cut-out portion **51b** is formed, is provided with an inclined portion **52h** formed to be inclined upward as it goes rearward from the front end portion **52a**. Thus, according to the slider **40** of the present embodiment, it is possible to guide the separable pin **16** and the elements **31** to the element guide passage **57**, thereby allowing the separable pin **16** and the elements **31** to be more simply inserted therein.

[0108] Further, in the slider **40** of the present embodiment, an upper surface of the front end portion **52a** on a part of the lower blade **52**, on the side of which the cut-out portion **51b** is formed, is provided with an introduction inside portion **52c** formed to be inclined upward as it goes toward the guide post **53**; an introduction outside portion **52d** formed to be inclined upward as it goes toward the outside; and an introduction middle portion **52b** formed in a recessed shape between the introduction inside portion **52c** and the introduction outside portion **52d**. Therefore, according to the slider **40** of the present embodiment, it is possible to guide the separable pin **16** and the elements **31** to the element guide passage **57**, thereby allowing the separable pin **16** and the elements **31** to be more simply inserted therein.

[0109] Further, in the slider **40** of the present embodiment, the lower blade **52** is formed such that a thickness of one of the left and right parts thereof, on the side of which the cut-out portion **51b** of the upper blade **51** is formed, is thinner than a thickness of the other of the left and right parts, on the side of which the cut-out portion **51b** of the upper blade **51** is not formed. Accordingly, the part of the lower blade **52**, which is located on one side in the width-wise direction with respect to the guide post **53**, can be configured to be easily bent. Therefore, it is possible to more easily separate one fastener stringer **11L** from the slider **40**.

[0110] As set forth above, the slide fastener **10** of the present embodiment includes a fastener chain **11** constituted of a pair of fastener stringers **11L**, **11R**, wherein the pair of fastener stringers **11L**, **11R** includes a pair of respective fastener tapes **20** and respective element rows **30**, wherein each of the element rows **30** is constituted of a plurality of elements **31** fixed on respective tape side edge portions **20a** of the pair of fastener tapes **20**, wherein the element rows **30** are arranged to oppose each other; and the slider **40** as described above attached to be slidable along the element rows **30** and configured to engage and disengage the elements **31**. Thus, according to the slide fastener **10** of the present embodiment, the slider **40** is provided, in which the insertion position of the separable pin **16** can be easily seen and also the lower blade **52** can guide the separable pin **16** and the elements **31**. Accordingly, the separable pin **16** and the elements **31** can be simply inserted into the slider **40**, which has a compact and simple structure and also a good operability.

[0111] Also, the slide fastener **10** of the present embodiment includes a top stop **12** formed at a top end of the tape

side edge portion **20a** of each of the pair of fastener tapes **20**; and an opener **13** formed on bottom ends of a tape side edge portions **20a** of the pair of fastener tapes **20**. Thus, according to the slide fastener **10** of the present embodiment, the slide fastener **10** can be applied to various products.

[0112] Although various embodiments of the present invention have been described, the present invention is not limited to the foregoing embodiments, and accordingly, any other embodiments constructed by appropriately combining configurations of the foregoing embodiments are intended to be encompassed by the scope of the invention.

#### REFERENCE NUMERALS LIST

[0113]	<b>10</b> . . . Slide fastener
[0114]	<b>11L</b> , <b>11R</b> . . . Fastener Stringer
[0115]	<b>12</b> . . . Top stop
[0116]	<b>13</b> . . . Opener
[0117]	<b>14</b> . . . Retainer pin
[0118]	<b>15</b> . . . Box body
[0119]	<b>16</b> . . . Separable pin
[0120]	<b>20</b> . . . Fastener tape
[0121]	<b>20a</b> . . . Tape side edge portion
[0122]	<b>30</b> . . . Element row
[0123]	<b>31</b> . . . Fastener element
[0124]	<b>40</b> . . . Slider
[0125]	<b>50</b> . . . Slider body
[0126]	<b>51</b> . . . Upper blade
[0127]	<b>51a</b> . . . Front end portion
[0128]	<b>51b</b> . . . Cut-out portion
[0129]	<b>51d</b> . . . Insertion direction indicator portion
[0130]	<b>52</b> . . . Lower blade
[0131]	<b>52a</b> . . . Front end portion
[0132]	<b>52b</b> . . . Introduction middle portion
[0133]	<b>52c</b> . . . Introduction inside portion
[0134]	<b>52d</b> . . . Introduction outside portion
[0135]	<b>52e</b> . . . Lower surface
[0136]	<b>52f</b> . . . Recess portion
[0137]	<b>52g</b> . . . Protrusion
[0138]	<b>53</b> . . . Guide post
[0139]	<b>53a</b> . . . Front lateral surface
[0140]	<b>53b</b> . . . Rear lateral surface
[0141]	<b>53c</b> . . . Front end portion
[0142]	<b>54a</b> . . . Upper flange
[0143]	<b>54b</b> . . . Lower flange
[0144]	<b>55</b> . . . Shoulder mouth
[0145]	<b>56</b> . . . Rear mouth
[0146]	<b>57</b> . . . Guide passage
[0147]	<b>58F</b> . . . Front attaching post
[0148]	<b>58B</b> . . . Rear attaching post
[0149]	<b>59a</b> , <b>59b</b> . . . Inclined surface
[0150]	<b>60</b> . . . Pull
[0151]	<b>61</b> . . . Link portion
[0152]	<b>70</b> . . . Stop claw body
[0153]	<b>71</b> . . . Stop claw
[0154]	<b>80</b> . . . Pull holding cover

1. A slider comprising:

a slider body including an upper blade and a lower blade arranged to be spaced from each other in an up-down direction and to be parallel to each other, a guide post connecting the upper blade and the lower blade, and a pull attachment portion provided on an upper surface of the upper blade; and

a pull attached to the pull attachment portion,

wherein a cut-out portion is formed on a front end portion of the upper blade at one of left and right sides with respect to the guide post, the cut-out portion is formed to be positioned at a rear side than a front end portion of the upper blade at the other of the left and right sides with respect to the guide post and than a front end portion of the lower blade.

2. The slider according to claim 1, wherein a distance from a front end portion of the guide post to the cut-out portion of the upper blade is longer than a distance from the front end portion of the guide post to the front end portion of the lower blade.

3. The slider according to claim 2, wherein the distance from the front end portion of the guide post to the front end portion of the lower blade is zero.

4. The slider according to claim 1, wherein the cut-out portion is formed to extend from one lateral surface of the guide post toward the outside.

5. The slider according to claim 1, wherein an upper surface of the lower blade, on a side at which the cut-out portion is formed, is provided with an inclined portion formed to be inclined upward as it goes rearward from the front end portion.

6. The slider according to claim 1, wherein an upper surface of the front end portion of the lower blade, on a side at which the cut-out portion is formed, is provided with:

- an introduction inside portion formed to be inclined upward as it goes toward the guide post;
- an introduction outside portion formed to be inclined upward as it goes toward the outside; and
- an introduction middle portion formed in a recessed shape between the introduction inside portion and the introduction outside portion.

7. The slider according to claim 1, wherein the lower blade is formed such that a thickness of one of left and right parts thereof, on a side at which the cut-out portion of the

upper blade is formed, is thinner than a thickness of the other of the left and right parts, on a side at which the cut-out portion of the upper blade is not formed.

8. A slide fastener comprising:

- a fastener chain in which a pair of fastener stringers including a pair of respective fastener tapes and respective element rows constituted of a plurality of elements fixed on respective tape side edge portions of the pair of fastener tapes are arranged so that the element rows are arranged to oppose each other; and

a slider including:

- a slider body including an upper blade and a lower blade arranged to be spaced from each other in an up-down direction and to be parallel to each other, a guide post connecting the upper blade and the lower blade, and a pull attachment portion provided on an upper surface of the upper blade; and
- a pull attached to the pull attachment portion,

wherein a cut-out portion is formed on a front end portion of the upper blade at one of left and right sides with respect to the guide post, and the cut-out portion is formed to be positioned at a rear side than a front end portion of the upper blade at the other of the left and right sides with respect to the guide post and than a front end portion of the lower blade, and

wherein the slider is attached to be slidable along the element rows and configured to engage and disengage the elements.

9. The slide fastener according to claim 8, further comprising:

- a top stop formed an top end of the tape side edge portion of each of the pair of fastener tapes; and
- an opener formed on bottom ends of a tape side edge portions of the pair of fastener tapes.

\* \* \* \* \*