



US 20200173707A1

(19) **United States**

(12) **Patent Application Publication**
CORDON COMPAÑ

(10) **Pub. No.: US 2020/0173707 A1**

(43) **Pub. Date: Jun. 4, 2020**

(54) **STOP SENSOR FOR AN ICE MACHINE**

Publication Classification

(71) Applicant: **INDUSTRIA TECNICA VALENCIANA, S.A.**, Valencia (ES)

(51) **Int. Cl.**
F25C 5/187 (2006.01)
F25C 1/00 (2006.01)

(72) Inventor: **Cristina CORDON COMPAÑ**, Valencia (ES)

(52) **U.S. Cl.**
CPC *F25C 5/187* (2013.01); *F25C 2700/02* (2013.01); *F25C 1/00* (2013.01)

(73) Assignee: **INDUSTRIA TECNICA VALENCIANA, S.A.**, Valencia (ES)

(57) **ABSTRACT**

(21) Appl. No.: **16/211,021**

A stop sensor for an ice machine comprising a casing made up of a base and a cover, wherein the base acts as a housing for a sensor protected by glass, and which is arranged in an electronic board which in turn houses at least electronic means which send the stop signal; a probe, a light emitting diode and a switch; and in that the cover of the casing has a hole wherein a cap is housed which protects the sensor from possible inlets of water during the operation of the machine, and wherein in turn, said hole will coincide with the area where the button of the switch is located.

(22) Filed: **Dec. 5, 2018**

(30) **Foreign Application Priority Data**

Dec. 3, 2018 (EP) 18382886.2

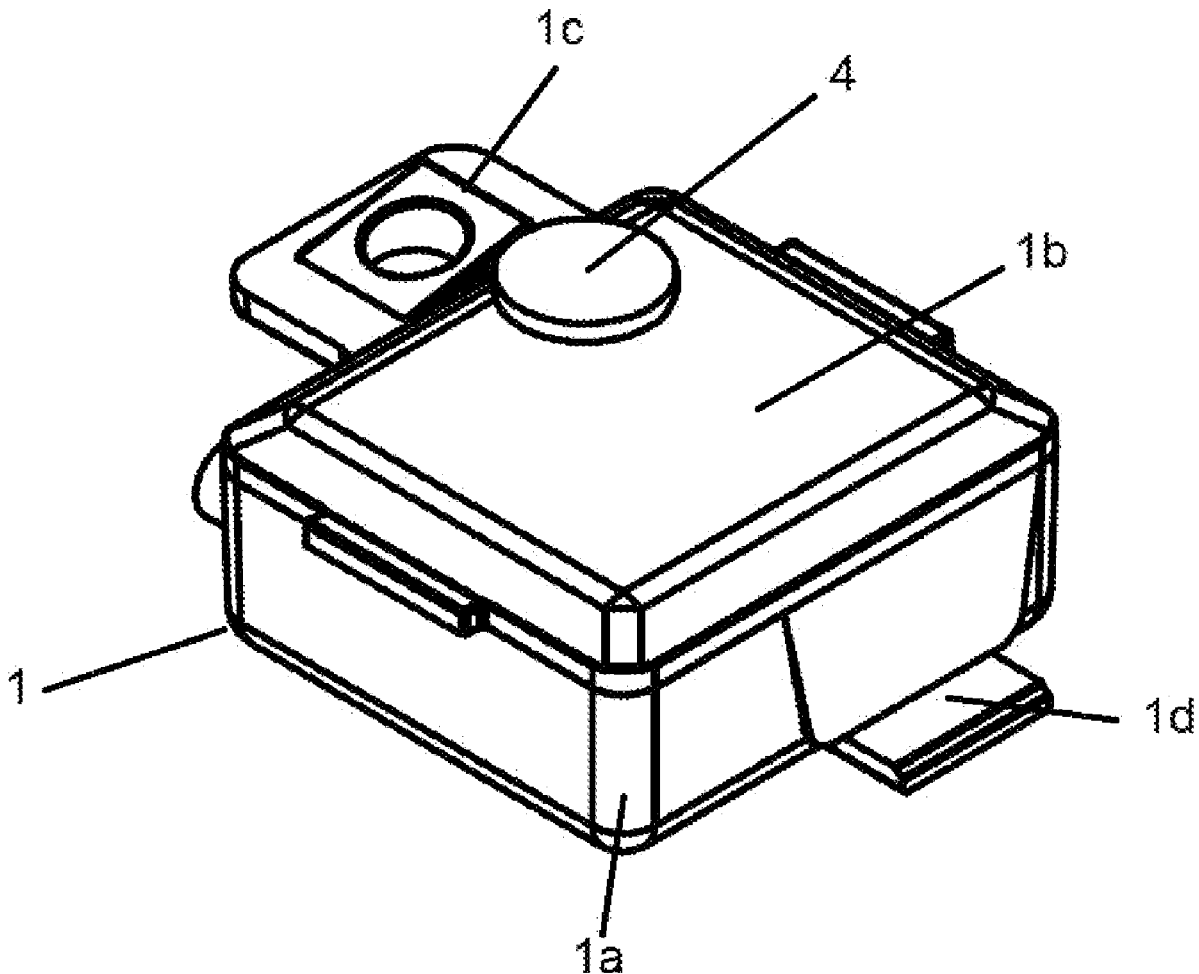

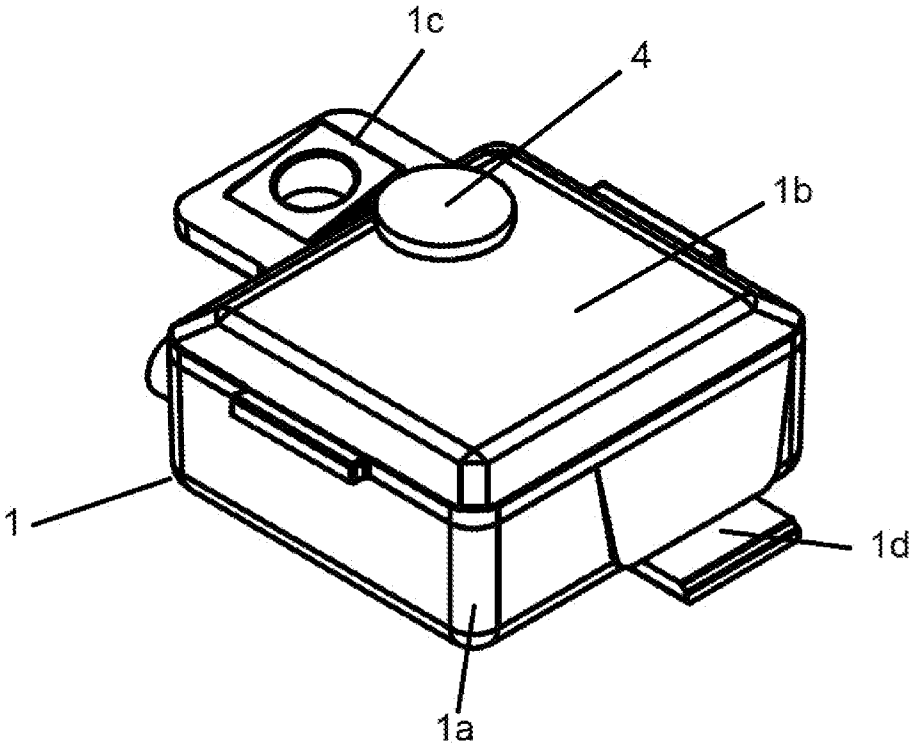

FIG.1

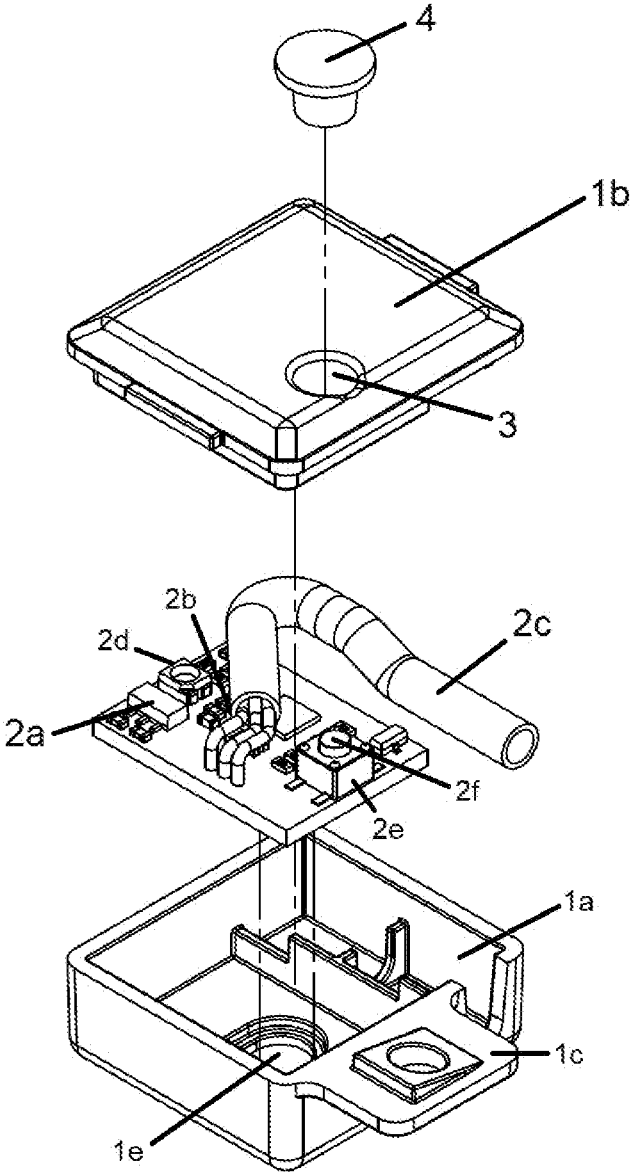

FIG.2

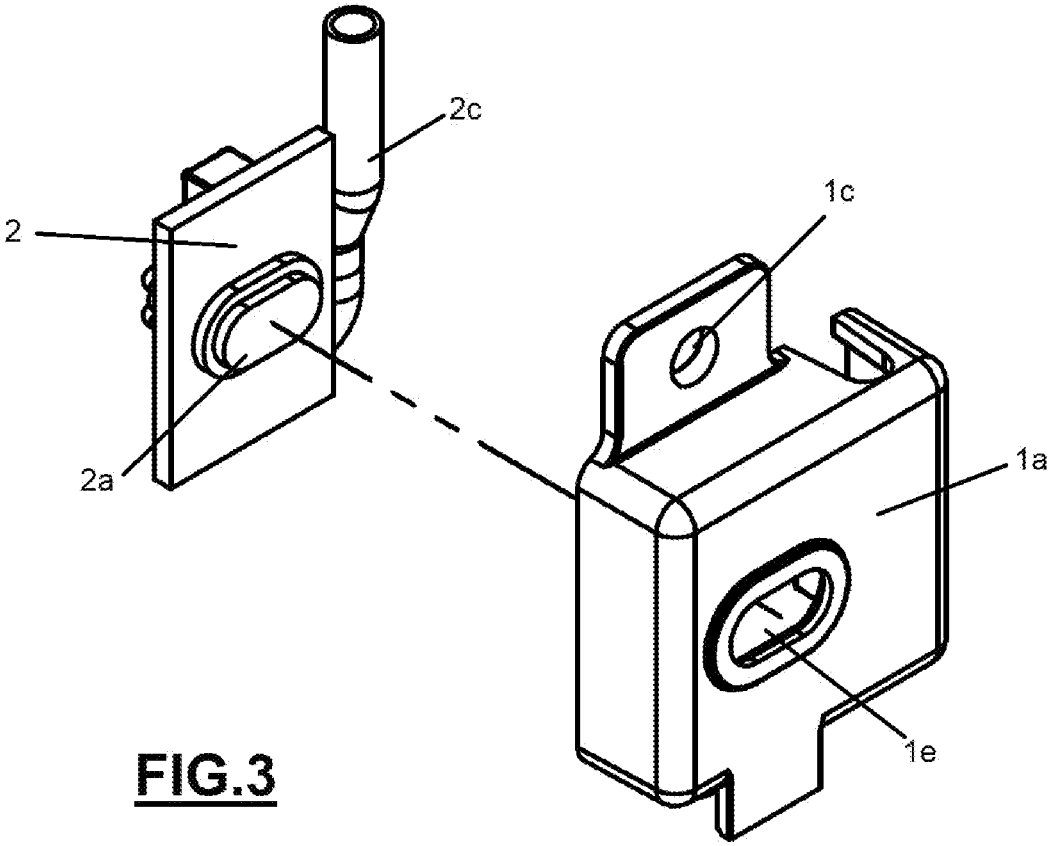

FIG.3

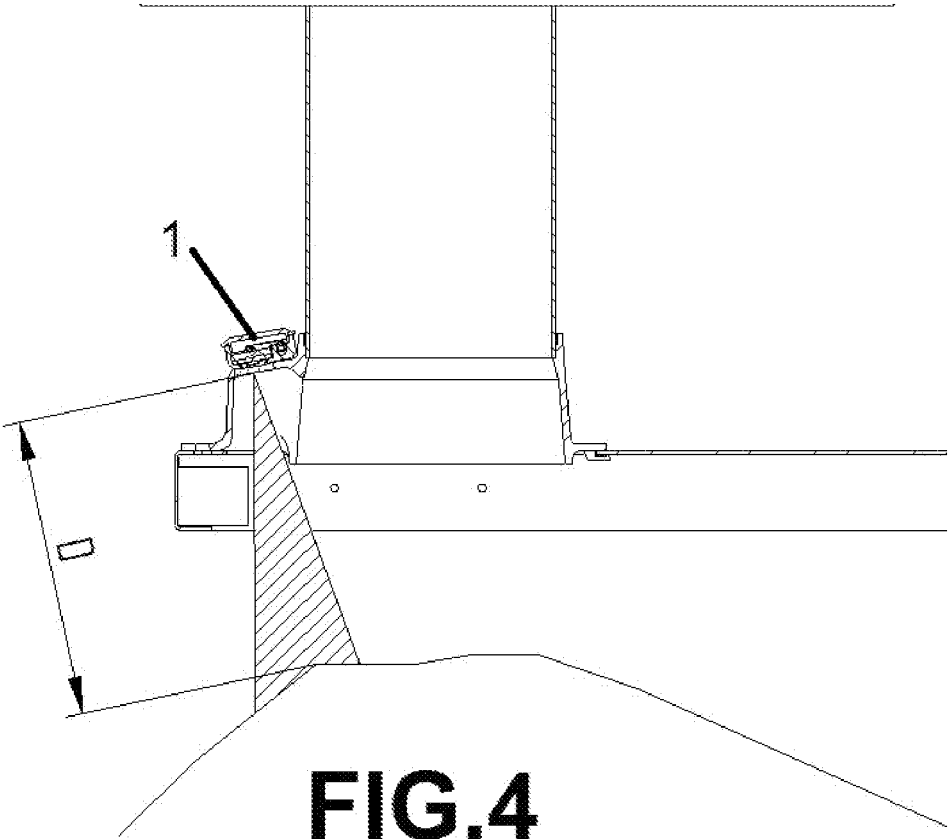

FIG.4

STOP SENSOR FOR AN ICE MACHINE

OBJECT OF THE INVENTION

[0001] The object of the present specification is a stop sensor for an ice machine, the function of which will be that of stopping the cited machine when the silo in which it is attached is full of ice, and once the ice has been released, the machine starts up again.

BACKGROUND OF THE INVENTION

[0002] Currently, in the field of manufacturing ice cubes, and more specifically in the machines designed to that purpose, there are diverse systems or means for detecting obstructions which emit a signal that stops the cited machine with the aim of preventing possible defects therein.

[0003] One of said means or devices are those commonly known as thermostats, wherein when the ice touches the bulb of the cited thermostat, the stopping will be activated. Thus, the described problem is solved; nevertheless, among the drawbacks of this solution is the fact that it is difficult to adjust to low ambient temperatures, which causes the installation thereof to not be viable at temperatures below 5° C.

[0004] Another type of solution is the one known as photoelectric sweeping, which is designed to respond to changes in the intensity of the light received, being activated in said cases. This type of solution has the main drawback of being very sensitive to ambient light; and furthermore, it is made up of an emitter and a receiver, therefore, it requires a more adjusted definition thereof, and requires greater maintenance than other similar solutions.

[0005] Finally, there are other machines which perform a complete mechanical stop thereof when they detect the problem. Nevertheless, this type of solution requires an operator to readjust the machine, and there is the risk that due to the stopping, certain components can become misaligned, which are necessary for the correct operations thereof. Therefore, the reliability of the solution is called into question.

DESCRIPTION OF THE INVENTION

[0006] The technical problem solved by the present invention is achieving a device that can determine the stopping of the machine when the silo where it is stored is full of ice and that in turn is able to reset the machine and determine the start-up thereof. To do so, the stop sensor for an ice machine, object of the present specification, is characterized in that it comprises a casing wherein the base thereof acts as a housing for a sensor protected by glass, and that is arranged in an electronic board which in turn houses at least electronic means that send the stop signal, a probe, a light emitting diode and a switch.

[0007] Due to the design thereof, the sensor contemplated herein will be able to measure the distance at which the object interrupting is, and therefore activate when it detects an anomaly, stopping the machine. Once the anomaly disappears, the machine will start up again.

[0008] The incorporation of the button will enable the distance at which the stop is activated to be regulated at will, with a maximum of two meters. This gives rise to the possibility of adjusting the filling for different types of installations (silo, chamber, etc.), thus, it will be able to be used in a greater number of ice-making machines.

Likewise, the regulation of the sensor will enable the operators thereof to be able to adapt the amount of ice stored to the needs required at any given time, such as for example, weekly, monthly, seasonally, etc.

[0009] Preferably, the sensor will be placed next to the outlet mouth for ice (shielded from drips and/or splashes), such that it is kept clean from lime or other deposits that could affect the measuring of the distance and therefore, of the correct operation thereof.

[0010] In turn, the sensor will be designed to work at low ambient temperatures, with a low sensitivity to ambient light.

BRIEF DESCRIPTION OF THE FIGURES

[0011] What follows is a very brief description of a series of drawings that aid in better understanding the invention and which are expressly related to an embodiment of said invention that is presented by way of a non-limiting example of the same.

[0012] FIG. 1. Shows a view of the stop sensor for an ice machine, object of the present specification.

[0013] FIG. 2. Shows an exploded view of the stop sensor for an ice machine.

[0014] FIG. 3. Shows a bottom view of the electronic board (2) as part of the stop sensor for an ice machine.

[0015] FIG. 4. Shows a view of the area of influence and detection of the sensor (2a) as part of the stop sensor for an ice machine.

DESCRIPTION OF A DETAILED EMBODIMENT OF THE INVENTION

[0016] The attached figures show a preferred embodiment of the invention. More specifically, the stop sensor for an ice machine, object of the present specification, is characterized in that it comprises a casing (1) made up of a base (1a) and a cover (1b), wherein the base (1a) which acts as a housing for a sensor (2a) protected by glass, and is arranged in an electronic board (2) which in turn houses at least electronic means (2b) which send the stop signal; a probe (2c), a light emitting diode (2d) and a switch (2e).

[0017] The electronic board (2) and a portion of the cable which makes up the probe (2c) have a layer of resin on the surface thereof, without surpassing the upper portion of the switch (2e), leaving the button (2f) free, preventing interferences with the lid (1b) of the casing (1).

[0018] The cover (1b) of the casing (1) has a hole (3) wherein a cap (4) is housed which protects the sensor from possible inlets of water during the operation of the machine, and wherein in turn, said hole (3) will coincide with the area where the button (2f) of the switch is located, such that it will not be necessary to take off the cover (1b) when the sensor (2a) is to be calibrated.

[0019] The base (1a) will have corresponding extensions (1c, 1d) which will facilitate the joining thereof to the ice-making machine. And a hollow (1e) where the sensor (2a) will be housed.

[0020] In a preferred embodiment, the sensor (2a) will detect a surface of up to two meters with a surface generated with an angle to the order of between 20° and 40°.

[0021] In a particular embodiment, the probe (2c) will have a length of up to two meters.

1. A stop sensor for an ice machine, the stop sensor comprising:

a casing, the casing including:
a base, and
a cover, wherein

the base acts as a housing for a sensor protected by glass,
and the sensor is arranged in or on an electronic board
which in turn houses at least electronic means which
send a stop signal;

a probe;
a light emitting diode; and
a switch having a button, wherein
the cover of the casing has a hole,
in the cover of the casing, a cap is housed which protects
the sensor from possible inlets of water,
said hole coincides with the area where the button of the
switch is located.

2. The stop sensor for the ice machine according to claim
1, wherein

the casing includes a lid,
the probe includes a cable,
the switch having an upper portion and a lower portion,
and
the electronic board and a portion of the cable have a layer
of resin on the surface thereof, without surpassing the
upper portion of the switch, leaving the button free,
preventing interferences with the lid of the casing.

3. The stop sensor for the ice machine according to claim
1, wherein

the base has corresponding extensions which facilitate a
joining of the stop sensor to the machine.

4. The stop sensor for the ice machine according to claim
1, wherein

the sensor is configured and/or programmed to detect a
surface of up to two meters with a surface generated
with an angle to the order of between 20° and 40°.

5. The stop sensor for the ice machine according to claim
1, wherein

the probe has a length of up to two meters.

6. The stop sensor for the ice machine according to claim
2, wherein

the base has corresponding extensions which facilitate a
joining of the stop sensor to the machine.

7. The stop sensor for the ice machine according to claim
2, wherein

the sensor is configured and/or programmed to detect a
surface of up to two meters with a surface generated
with an angle to the order of between 20° and 40°.

8. The stop sensor for the ice machine according to claim
3, wherein

the sensor is configured and/or programmed to detect a
surface of up to two meters with a surface generated
with an angle to the order of between 20° and 40°.

9. The stop sensor for the ice machine according to claim
6, wherein

the sensor is configured and/or programmed to detect a
surface of up to two meters with a surface generated
with an angle to the order of between 20° and 40°.

10. The stop sensor for the ice machine according to claim
2, wherein

the probe has a length of up to two meters.

11. The stop sensor for the ice machine according to claim
3, wherein

the probe has a length of up to two meters.

12. The stop sensor for the ice machine according to claim
4, wherein

the probe has a length of up to two meters.

13. The stop sensor for the ice machine according to claim
6, wherein

the probe has a length of up to two meters.

14. The stop sensor for the ice machine according to claim
7, wherein

the probe has a length of up to two meters.

15. The stop sensor for the ice machine according to claim
8, wherein

the probe has a length of up to two meters.

16. The stop sensor for the ice machine according to claim
9, wherein

the probe has a length of up to two meters.

* * * * *