



(12) **United States Patent**
Jertson et al.

(10) **Patent No.:** **US 11,819,740 B2**
(45) **Date of Patent:** **Nov. 21, 2023**

- (54) **GOLF CLUB HEADS WITH ENERGY STORAGE CHARACTERISTICS**
- (71) Applicant: **KARSTEN MANUFACTURING CORPORATION**, Phoenix, AZ (US)
- (72) Inventors: **Martin R. Jertson**, Cave Creek, AZ (US); **Eric J. Morales**, Laveen, AZ (US); **Cory S. Bacon**, Cave Creek, AZ (US); **Calvin Wang**, Chandler, AZ (US); **Xiaojian Chen**, Phoenix, AZ (US)
- (73) Assignee: **Karsten Manufacturing Corporation**, Phoenix, AZ (US)

(*) Notice: Subject to any disclaimer, the term of this patent is extended or adjusted under 35 U.S.C. 154(b) by 246 days.

(21) Appl. No.: **15/908,427**
(22) Filed: **Feb. 28, 2018**

- (65) **Prior Publication Data**
US 2018/0185714 A1 Jul. 5, 2018
- Related U.S. Application Data**
- (63) Continuation-in-part of application No. 14/920,484, filed on Oct. 22, 2015, now abandoned.
(Continued)

- (51) **Int. Cl.**
A63B 53/04 (2015.01)
- (52) **U.S. Cl.**
CPC **A63B 53/04** (2013.01); **A63B 53/0466** (2013.01); **A63B 53/0475** (2013.01);
(Continued)

- (58) **Field of Classification Search**
CPC . A63B 53/04; A63B 53/0466; A63B 53/0475; A63B 53/0412; A63B 53/0437; A63B 53/0433; A63B 53/0408
See application file for complete search history.

- (56) **References Cited**
U.S. PATENT DOCUMENTS
4,667,963 A * 5/1987 Yoneyama A63B 53/04 473/348
5,090,702 A * 2/1992 Viste A63B 53/04 473/331

(Continued)

- FOREIGN PATENT DOCUMENTS
CN 10474085 7/2015
JP 2003062132 3/2003
(Continued)

OTHER PUBLICATIONS
PCT International Search Report and Written Opinion from PCT Application No. PCT/US15/56933, filed Oct. 22, 2015.
(Continued)

Primary Examiner — William M Pierce

- (57) **ABSTRACT**
Embodiments of golf club heads with energy storage characteristics are presented herein. In some embodiments, a golf club head comprises a hollow body comprising a strikeface, a heel region, a toe region opposite the heel region, a sole, and a crown. In many embodiments, the crown comprises an upper region comprising a top rail and a lower region. In some embodiments, a cavity is located below the top rail, is located above the lower region of the crown, and is defined at least in part by the upper and lower regions of the crown. The cavity comprises a top wall, a back wall, a bottom incline, a back cavity angle measured between the top and back walls of the cavity and at least one channel.

20 Claims, 12 Drawing Sheets

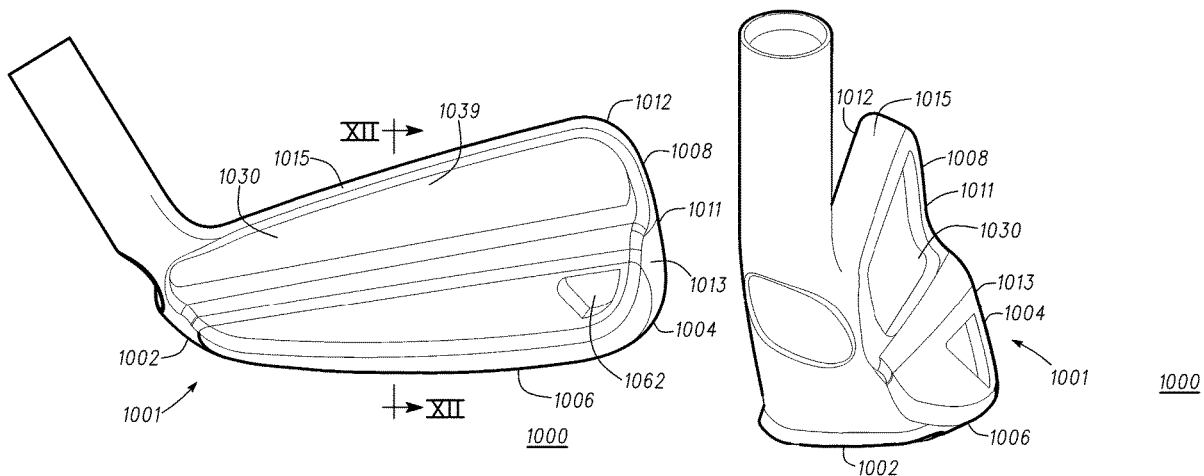

Related U.S. Application Data

(60) Provisional application No. 62/206,152, filed on Aug. 17, 2015, provisional application No. 62/131,739, filed on Mar. 11, 2015, provisional application No. 62/105,460, filed on Jan. 20, 2015, provisional application No. 62/105,464, filed on Jan. 20, 2015, provisional application No. 62/068,232, filed on Oct. 24, 2014.

(52) **U.S. Cl.**
 CPC *A63B 53/0408* (2020.08); *A63B 53/0412* (2020.08); *A63B 53/0433* (2020.08); *A63B 53/0437* (2020.08)

(56) **References Cited**

U.S. PATENT DOCUMENTS

5,163,682 A * 11/1992 Schmidt A63B 53/04
 473/332
 5,180,166 A * 1/1993 Schmidt A63B 53/04
 473/332
 5,184,823 A * 2/1993 Desboilles A63B 53/04
 473/345
 5,766,092 A * 6/1998 Mimeur A63B 53/04
 473/329
 6,306,048 B1 * 10/2001 McCabe A63B 53/04
 473/333
 6,348,013 B1 2/2002 Kosmatka
 6,379,265 B1 4/2002 Hirakawa et al.
 6,482,104 B1 * 11/2002 Gilbert A63B 53/04
 473/287
 6,533,679 B1 3/2003 McCabe et al.
 6,572,491 B2 6/2003 Hasebe et al.
 6,695,714 B1 * 2/2004 Bliss A63B 53/047
 473/328
 6,780,123 B2 * 8/2004 Hasebe A63B 53/04
 473/291
 6,811,496 B2 * 11/2004 Wahl A63B 53/047
 473/334
 6,971,961 B2 * 12/2005 Chen A63B 53/04
 473/342
 7,029,403 B2 * 4/2006 Rice A63B 53/0466
 473/329
 7,232,381 B2 * 6/2007 Imamoto A63B 53/047
 473/345
 7,337,861 B2 5/2008 Tateno et al.
 7,431,668 B2 10/2008 Tateno et al.
 7,435,191 B2 10/2008 Tateno et al.
 7,448,964 B2 11/2008 Schweigert et al.
 7,455,597 B2 * 11/2008 Matsunaga A63B 53/0466
 473/329
 7,470,200 B2 12/2008 Sanchez
 7,503,853 B2 3/2009 Matsunaga
 7,513,836 B2 * 4/2009 Matsunaga A63B 53/0466
 473/345
 7,549,934 B2 * 6/2009 Rice A63B 60/00
 473/329
 7,588,504 B2 9/2009 Matsunaga
 7,704,162 B2 * 4/2010 Rice A63B 60/00
 473/329
 7,758,440 B2 * 7/2010 Llewellyn A63B 53/0466
 473/244
 7,798,915 B2 9/2010 Matsunaga
 7,922,604 B2 * 4/2011 Roach A63B 53/047
 473/350
 7,935,001 B2 * 5/2011 Meyer A63B 53/0466
 473/314
 8,012,040 B2 * 9/2011 Takechi A63B 53/047
 473/329

8,043,165 B2 10/2011 Galloway
 8,109,842 B2 2/2012 Matsunaga
 8,182,365 B2 5/2012 Wada et al.
 8,235,841 B2 * 8/2012 Stites A63B 53/04
 473/328
 8,277,337 B2 10/2012 Shimazaki
 8,449,406 B1 * 5/2013 Frame A63B 53/04
 473/329
 8,647,217 B2 2/2014 Nishio
 8,651,975 B2 2/2014 Soracco
 8,657,703 B2 2/2014 Wada et al.
 8,753,230 B2 * 6/2014 Stokke A63B 53/047
 473/350
 8,870,681 B2 10/2014 Yamamoto
 8,961,336 B1 * 2/2015 Parsons A63B 53/0475
 473/332
 9,011,266 B2 * 4/2015 Brunski A63B 60/42
 473/345
 9,044,653 B2 6/2015 Wahl et al.
 9,079,078 B2 7/2015 Greensmith et al.
 9,089,747 B2 7/2015 Boyd et al.
 9,168,435 B1 * 10/2015 Boggs A63B 53/04
 9,265,995 B2 2/2016 Roberts et al.
 9,415,280 B2 8/2016 Stokke et al.
 9,908,018 B2 3/2018 Roberts et al.
 9,937,396 B2 4/2018 Stites et al.
 10,099,103 B2 * 10/2018 Golden A63B 60/54
 2003/0176231 A1 * 9/2003 Hasebe A63B 53/04
 473/291
 2011/0111883 A1 * 5/2011 Cackett A63B 53/047
 473/331
 2011/0183776 A1 7/2011 Breier et al.
 2012/0149494 A1 * 6/2012 Takahashi A63B 53/0466
 473/345
 2013/0109500 A1 * 5/2013 Boyd A63B 53/047
 473/332
 2013/0225319 A1 * 8/2013 Kato A63B 53/047
 473/331
 2013/0281229 A1 10/2013 Su
 2013/0331201 A1 * 12/2013 Wahl A63B 53/0475
 473/329
 2014/0087892 A1 * 3/2014 Taylor A63B 53/047
 473/305
 2015/0231454 A1 * 8/2015 Parsons A63B 53/0475
 473/335
 2015/0231806 A1 * 8/2015 Parsons B29C 45/14467
 264/261

FOREIGN PATENT DOCUMENTS

JP 2006212066 8/2006
 JP 2008054985 3/2008
 JP 2010167131 8/2010
 JP 5315577 7/2013
 JP 5763701 6/2015

OTHER PUBLICATIONS

http://www.golfworks.com/product.asp_Q_pn_E_MA0225_A_Maltby+DBM+Forged+Iron+Heads_A_c2p_E_cs, "Maltby Dbm Forged Head", Accessed Oct. 15, 2005.
<http://www.golfalot.com/equipment-news/taylormade-sldr-irons-2857.aspx>, "Taylor Made Sldr Irons", Published May 5, 2014, Accessed Oct. 15, 2015.
<http://www.golfwrx.com/322138/you-can-see-inside-cobras-king-ltd-drivers-andfairway-woods/>, "You can see inside Cobra's King Ltd drivers and fairway woods", Zak Kozuchowski, Accessed on Oct. 15, 2015.

* cited by examiner

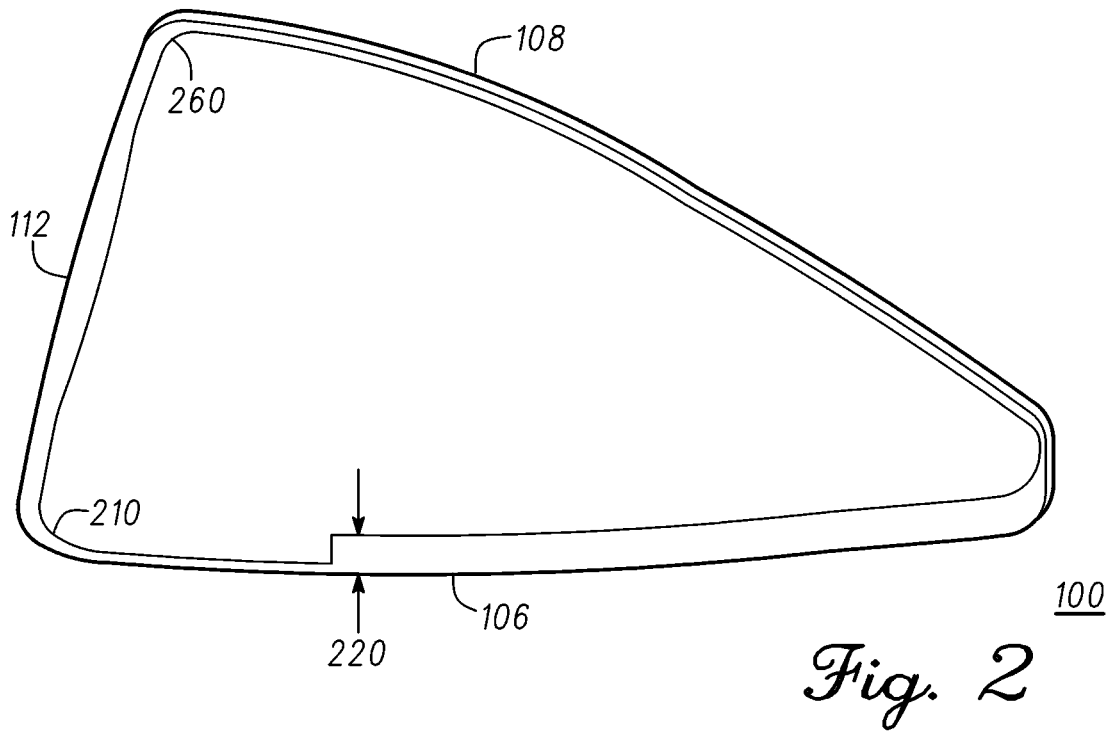
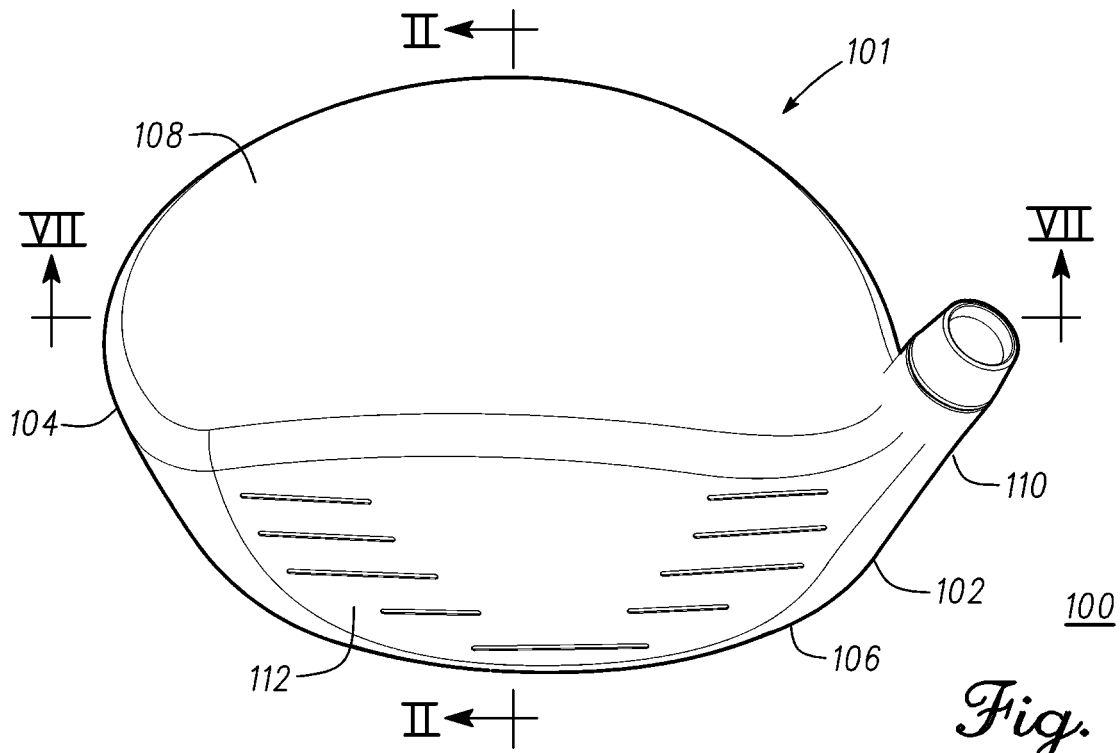

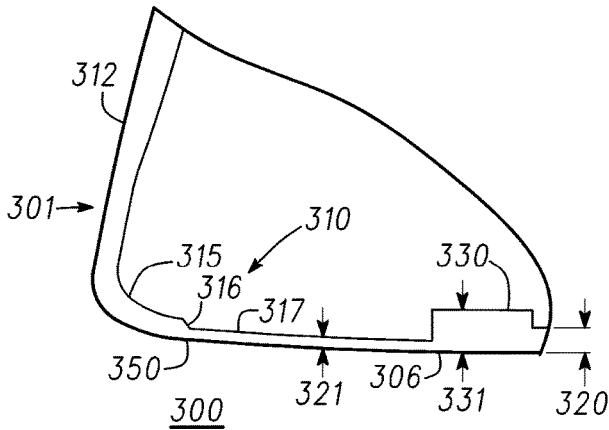

Fig. 3

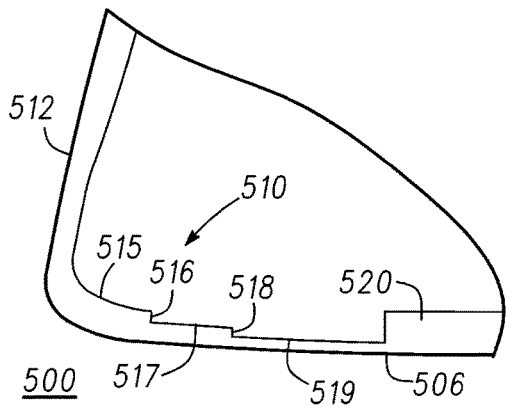
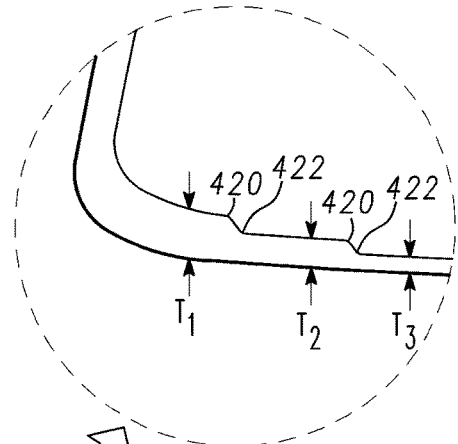

Fig. 5

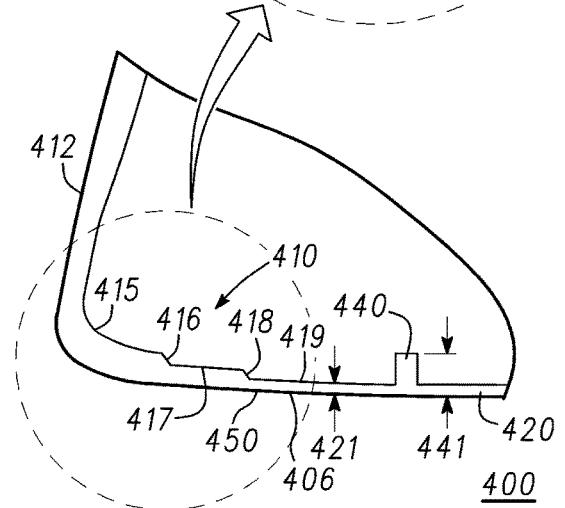

Fig. 4

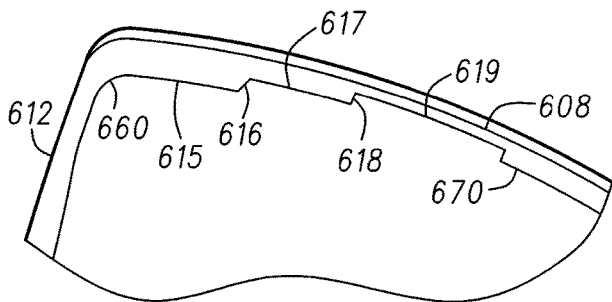

Fig. 6

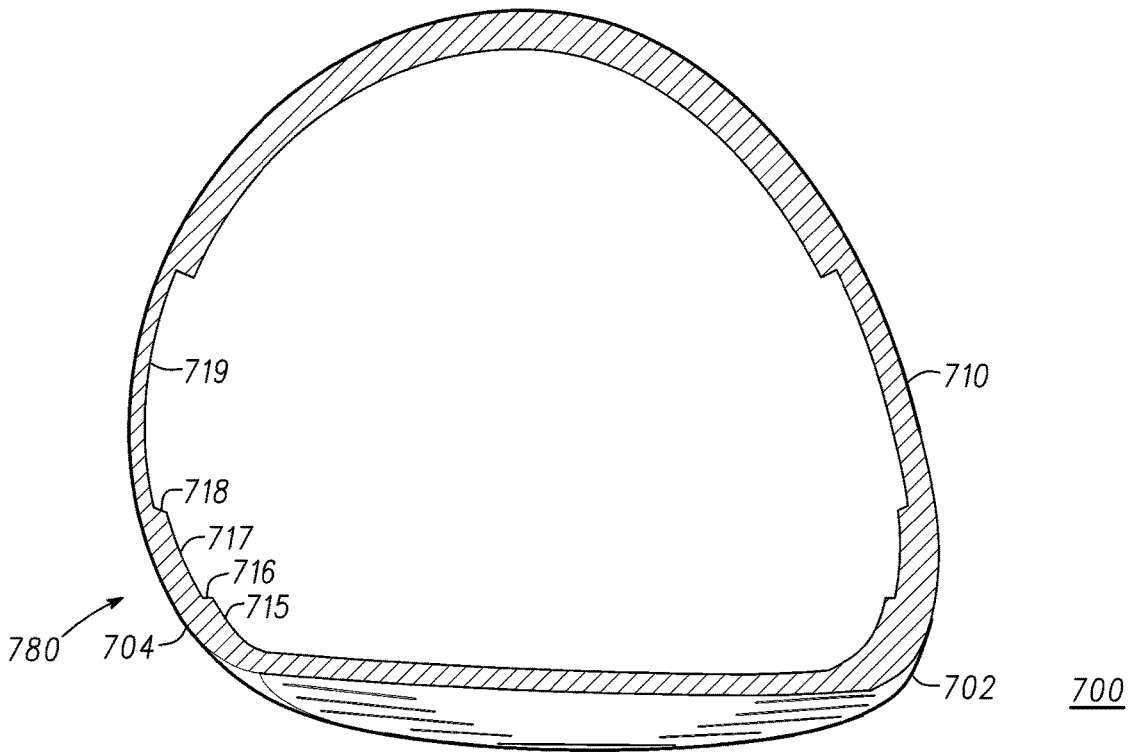

Fig. 7

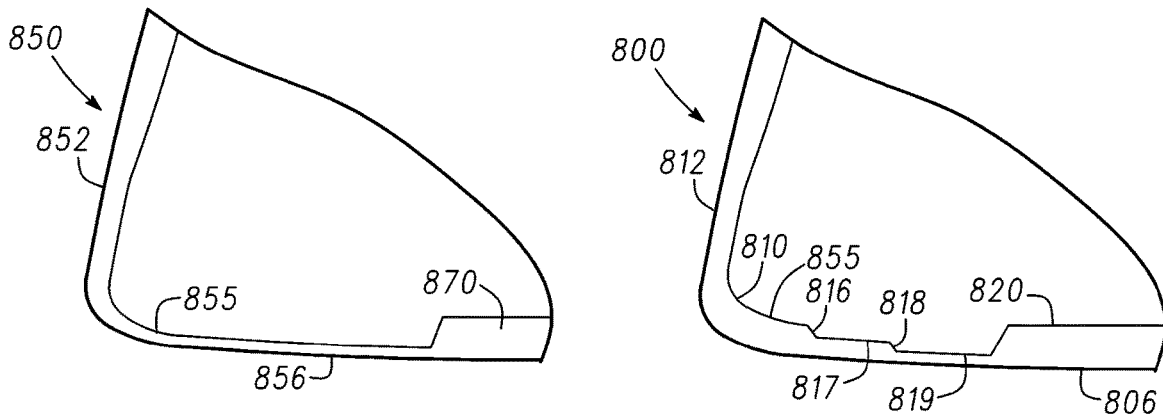
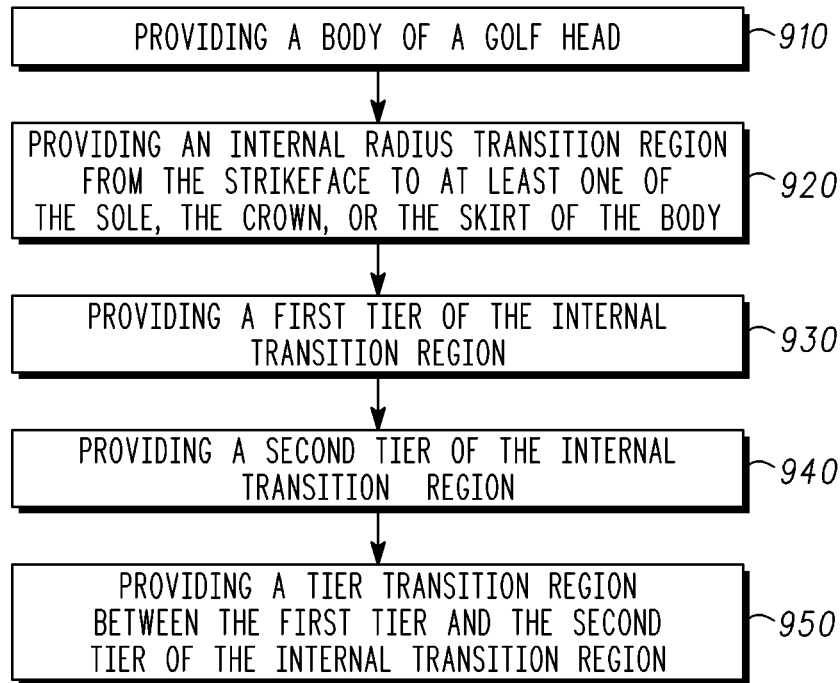

Fig. 8



900

Fig. 9

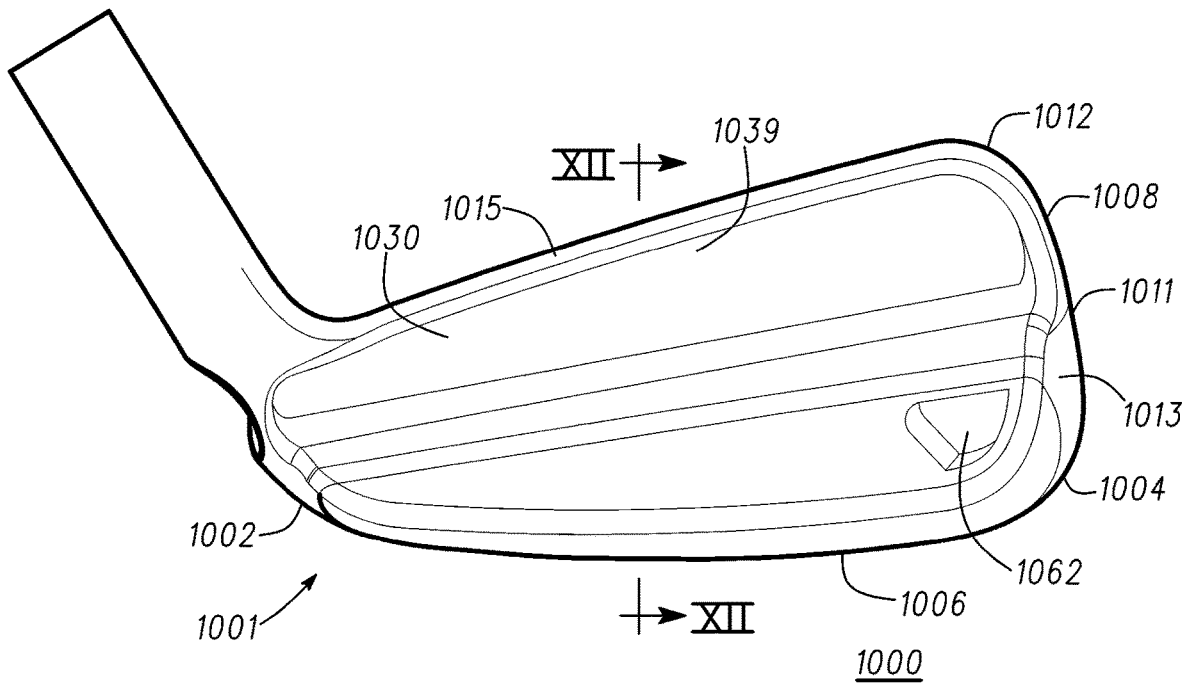

Fig. 10

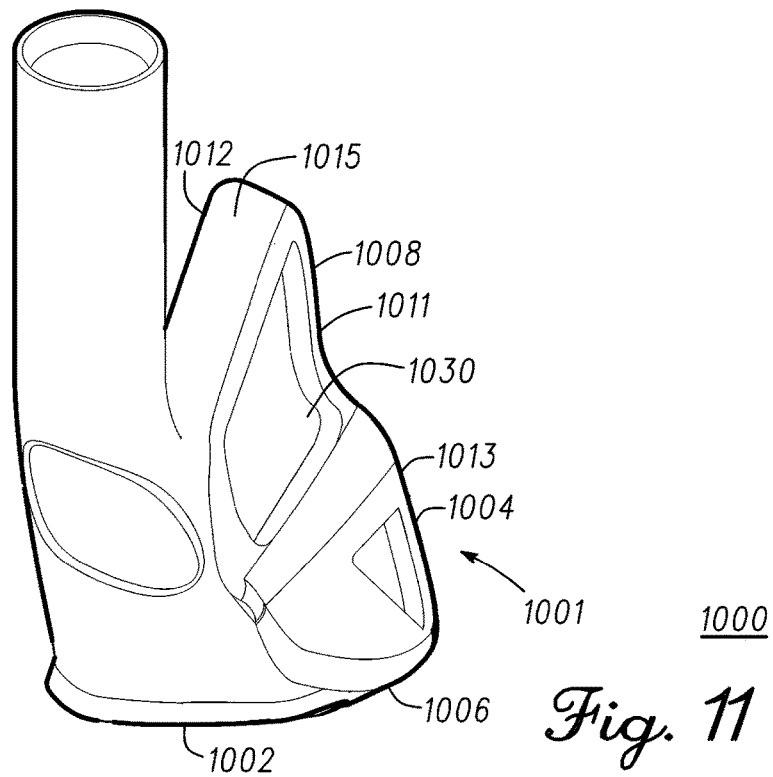
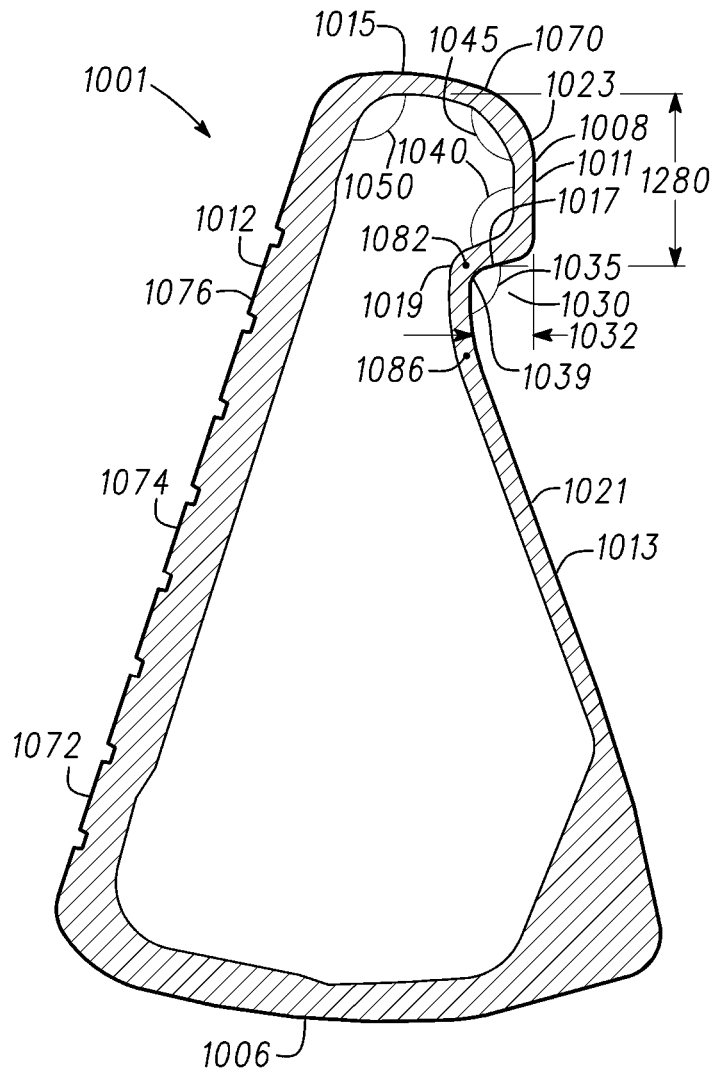

Fig. 11



1000

Fig. 12

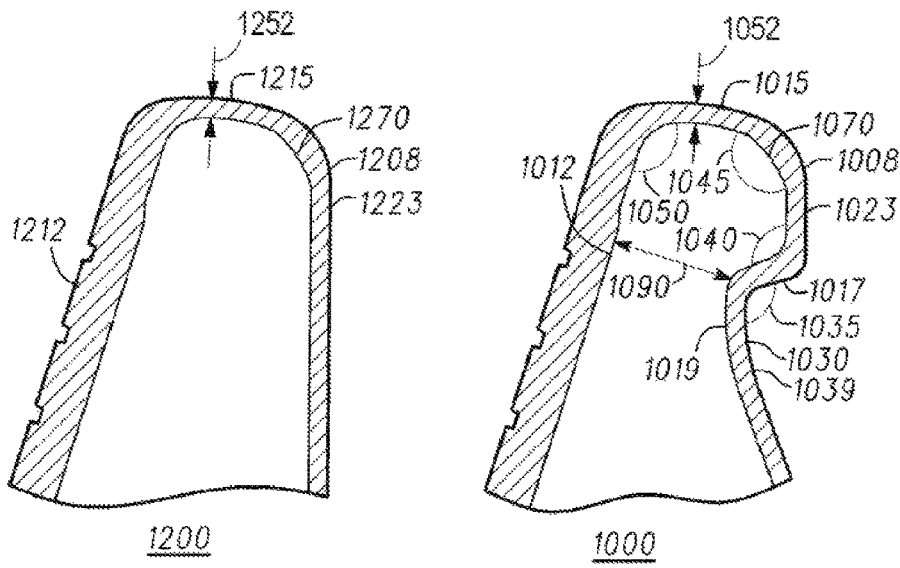

Fig. 13

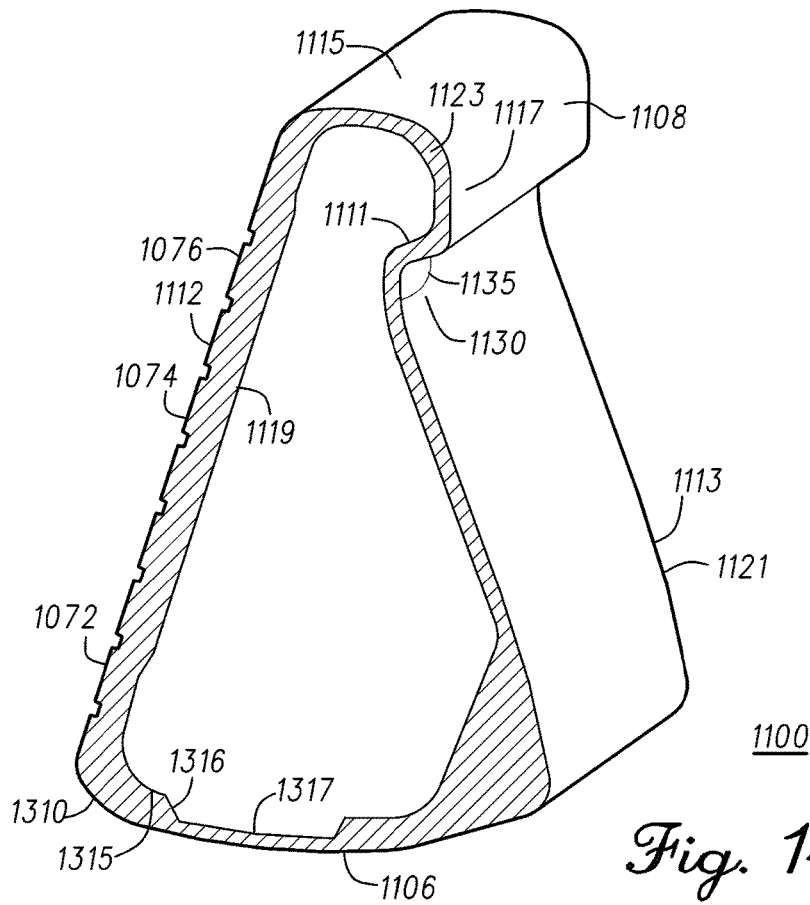

Fig. 14

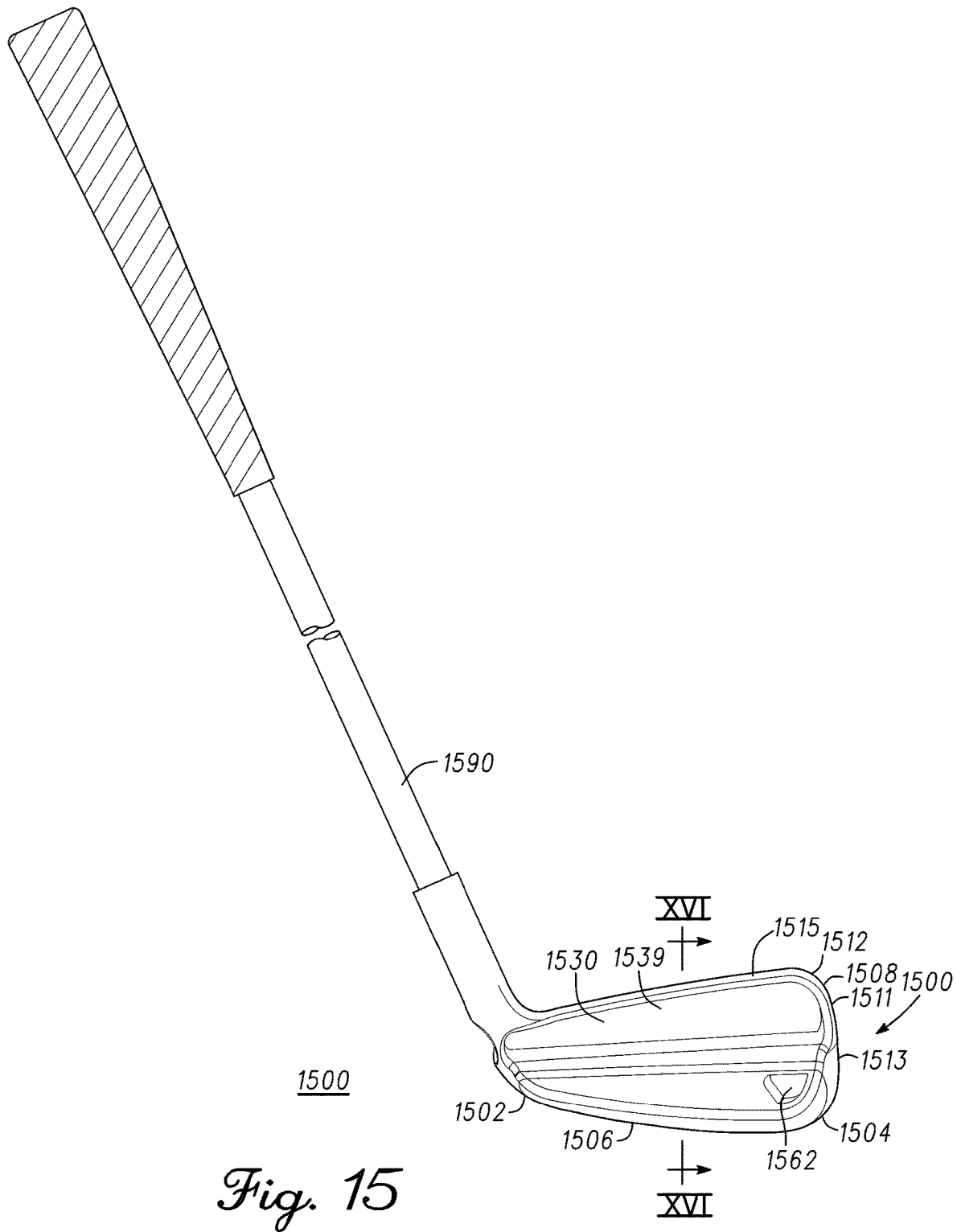

Fig. 15

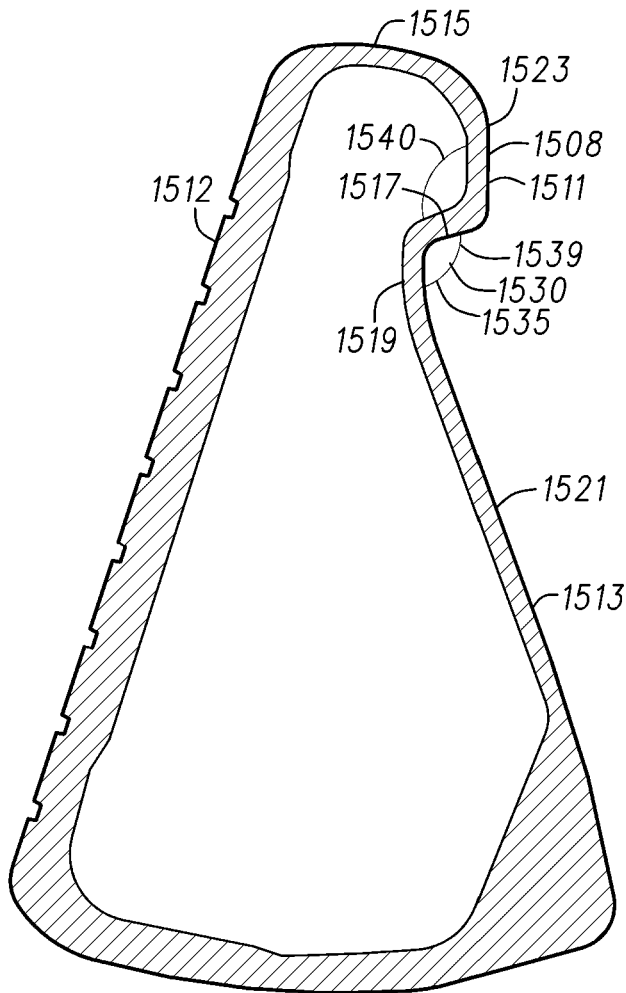

Fig. 16

PROVIDING A BODY, THE BODY HOUSING, A STRIKEFACE, A HEEL REGION, A TOE REGION OPPOSITE THE HEEL REGION, A SOLE, AND A CROWN COMPRISING AN UPPER REGION COMPRISING A TOP RAIL AND A LOWER REGION 1705

↓

PROVIDING A CAVITY LOCATED BELOW THE TOP RAIL, ABOVE THE LOWER REGION OF THE CROWN, AND IS DEFINED AT LEAST IN PART BY THE UPPER AND LOWER REGIONS OF THE CROWN 1710

1700

Fig. 17

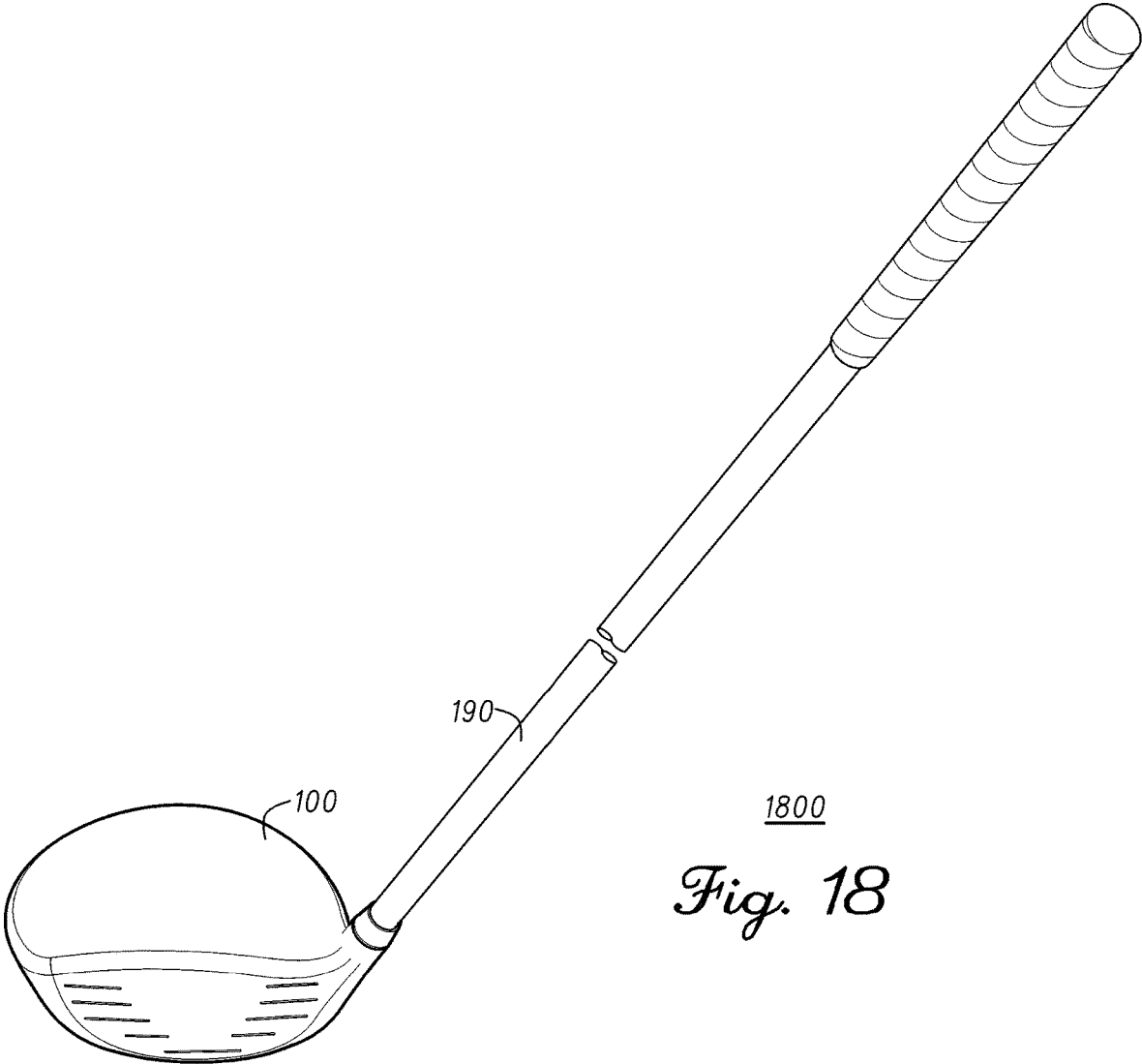

1800
Fig. 18

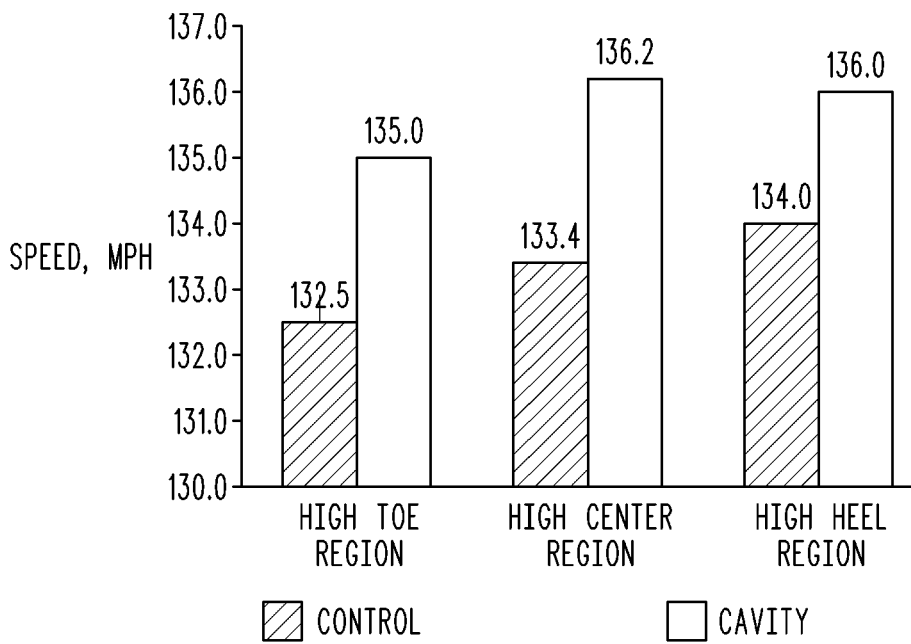

Fig. 19

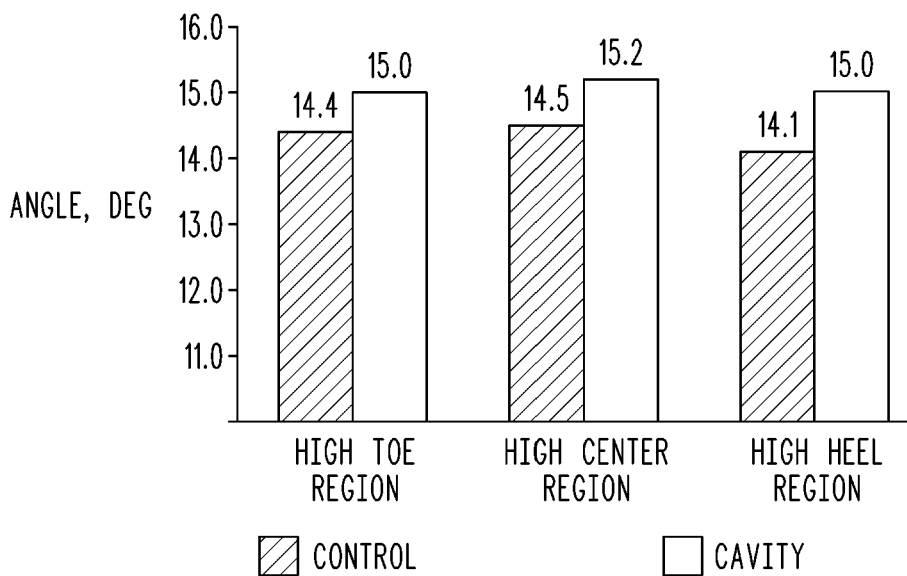
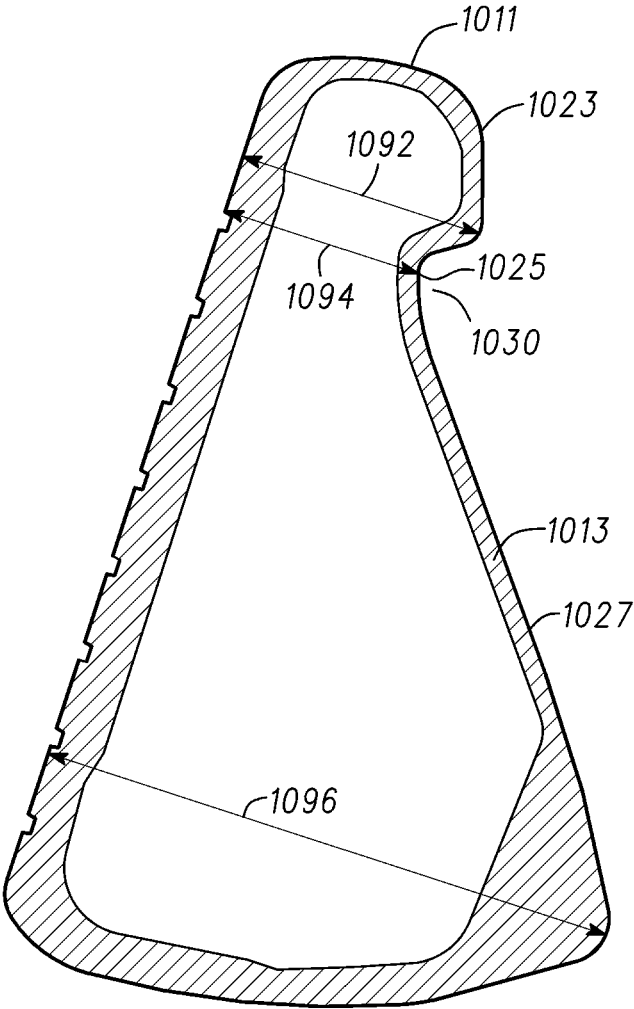

Fig. 20



1000

Fig. 21

GOLF CLUB HEADS WITH ENERGY STORAGE CHARACTERISTICS

CROSS-REFERENCE TO RELATED APPLICATIONS

This is a continuation in part of U.S. patent application Ser. No. 14/920,484, filed on Oct. 22, 2015, which claims priority to U.S. Provisional Application No. 62/206,152, filed Aug. 17, 2015, U.S. Provisional Application No. 62/131,739, filed Mar. 11, 2015, U.S. Provisional Application No. 62/105,460, filed Jan. 20, 2015, U.S. Provisional Application No. 62/105,464, filed Jan. 20, 2015, and U.S. Provisional Application No. 62/068,232, filed Oct. 24, 2014, all of which are incorporated by reference herein in their entirety.

TECHNICAL FIELD

This disclosure relates generally to golf clubs, and relates more particularly to golf club heads with energy storage characteristics.

BACKGROUND

Golf club manufacturers have designed golf club heads to relieve stress in the strikeface of the golf club head. In many instances, these designs do not allow the golf club head to flex in the crown to sole direction. Additionally, these designs may not change where peak bending of the golf club head occurs and do not allow additional storage of spring energy in the golf club head due to impact with the golf ball. Additional spring energy can increase ball speed across the strikeface.

BRIEF DESCRIPTION OF THE DRAWINGS

To facilitate further description of the embodiments, the following drawings are provided in which:

FIG. 1 depicts a front, crown-side perspective view of a golf club head according to an embodiment;

FIG. 2 depicts the golf club head of FIG. 1 along the cross-sectional line II-II in FIG. 1;

FIG. 3 depicts a view of a portion of a golf club head that is similar to the golf club head of FIG. 1, along a cross-sectional line similar to the cross-sectional line II-II in FIG. 1, according to another embodiment;

FIG. 4 depicts a view of a portion of a golf club head that is similar to the golf club head of FIG. 1, along a cross-sectional line similar to the cross-sectional line II-II in FIG. 1, according to another embodiment;

FIG. 5 depicts a view of a portion of a golf club head that is similar to the golf club head of FIG. 1, along a cross-sectional line similar to the cross-sectional line II-II in FIG. 1, according to another embodiment;

FIG. 6 depicts a view of another portion of a golf club head that is similar to the golf club head of FIG. 1, along a cross-sectional line similar to the cross-sectional line II-II in FIG. 1, according to another embodiment;

FIG. 7 depicts a cross-sectional view of a golf club similar to the golf club head of FIG. 1 along a similar cross-sectional line as the cross-sectional line VII-VII in FIG. 1, according to another embodiment;

FIG. 8 depicts a view of a portion of a golf club head similar to the golf club head of FIG. 4, according to an embodiment, and a view of the same area of a standard golf club head;

FIG. 9 depicts a method of manufacturing a golf club head according to an embodiment of a method.

FIG. 10 depicts a back, toe-side perspective view of a golf club head according to an embodiment;

FIG. 11 depicts a back, heel-side perspective view of the golf club head according to the embodiment of FIG. 10;

FIG. 12 depicts a cross-sectional view of the golf club head of FIG. 10 along the cross-sectional line XII-XII of FIG. 10;

FIG. 13 depicts a view of a portion of the golf club head of FIG. 12 and a view of the same area of a standard golf club head;

FIG. 14 depicts a cross-section view of a golf club head, similar to the golf club head of FIG. 10, along a cross-sectional line similar to cross-sectional line XII-XII of FIG. 10, according to another embodiment;

FIG. 15 depicts a back, toe-side perspective view of a golf club according to another embodiment;

FIG. 16 depicts a cross-sectional view of the golf club head of FIG. 15 along the cross-sectional line XVI-XVI of FIG. 15;

FIG. 17 depicts a flow diagram illustrating a method of manufacturing a golf club head according to an embodiment of another method;

FIG. 18 depicts a front perspective view of a golf club according to another embodiment;

FIG. 19 depicts results from testing of the golf club head of FIG. 14, according to another embodiment; and

FIG. 20 depicts results from testing of the golf club head of FIG. 14, according to another embodiment.

FIG. 21 depicts a cross sectional view of the golf club head of FIG. 10.

For simplicity and clarity of illustration, the drawing figures illustrate the general manner of construction, and descriptions and details of well-known features and techniques may be omitted to avoid unnecessarily obscuring the golf clubs and their methods of manufacture. Additionally, elements in the drawing figures are not necessarily drawn to scale. For example, the dimensions of some of the elements in the figures may be exaggerated relative to other elements to help improve understanding of embodiments of the golf clubs and their methods of manufacture. The same reference numerals in different figures denote the same elements.

The terms "first," "second," "third," "fourth," and the like in the description and in the claims, if any, are used for distinguishing between similar elements and not necessarily for describing a particular sequential or chronological order. It is to be understood that the terms so used are interchangeable under appropriate circumstances such that the embodiments of golf clubs and methods of manufacture described herein are, for example, capable of operation in sequences other than those illustrated or otherwise described herein. Furthermore, the terms "contain," "include," and "have," and any variations thereof, are intended to cover a non-exclusive inclusion, such that a process, method, article, or apparatus that comprises a list of elements is not necessarily limited to those elements, but may include other elements not expressly listed or inherent to such process, method, article, or apparatus.

The terms "left," "right," "front," "back," "top," "bottom," "side," "under," "over," and the like in the description and in the claims, if any, are used for descriptive purposes and not necessarily for describing permanent relative positions. It is to be understood that the terms so used are interchangeable under appropriate circumstances such that the embodiments of golf clubs and methods of manufacture described herein are, for example, capable of operation in

other orientations than those illustrated or otherwise described herein. The term “coupled,” as used herein, is defined as directly or indirectly connected in a physical, mechanical, or other manner.

DESCRIPTION OF EXAMPLES OF EMBODIMENTS

Various embodiments of the golf club heads with tiered internal thin sections include a golf club head comprising a body. The body comprises a strikeface, a heel region, a toe region opposite the heel region, a sole, a crown, and an internal radius transition region from the strikeface to at least one of the sole or the crown. In many embodiments, the internal radius transition region is not visible from an exterior of the golf club head and comprises a first tier, a second tier, and a tier transition region between the first tier and the second tier.

Another embodiment of the golf club heads with tiered internal thin sections include a golf club comprising a golf club head and a shaft coupled to the golf club head. The golf club head comprises a strikeface, a heel region, a toe region opposite the heel region, a sole, a crown, and an internal radius transition region from the strikeface to at least one of the sole or the crown. In many embodiments, the internal radius transition region is not visible from an exterior of the golf club head and comprises a first tier, a second tier, and a tier transition region between the first tier and the second tier.

Other embodiments of the golf club heads with tiered internal thin sections include a method for manufacturing a golf club head. The method comprises providing a body. The body comprises a strikeface, a heel region, a toe region opposite the heel region, a sole, and a crown. The method further comprises providing an internal radius transition region from the strikeface to at least one of the sole or the crown. The internal radius transition region is not visible from an exterior of the golf club head and comprises a first tier, a second tier, and a tier transition region between the first tier and the second tier. In many embodiments, the first tier has a first thickness, the second tier has a second thickness, and the second thickness is smaller than the first thickness.

Various embodiments include a golf club head comprising a hollow body. The hollow body comprises a strikeface, a heel region, a toe region opposite the heel region, a sole, and a crown. In many embodiments, the crown comprises an upper region comprising a top rail, and a lower region. In some embodiments, a cavity is located below the top rail, is located above the lower region of the crown, and is defined at least in part by the upper and lower regions of the crown. In many embodiments, the cavity comprises a top wall, a back wall, a bottom incline, a back cavity angle measured between the top and back walls of the cavity, and at least one channel.

Some embodiments include a golf club comprising a hollow-bodied golf club and a shaft coupled to the hollow-bodied golf club head. The hollow-bodied golf club head comprises a strikeface, a heel region, a toe region opposite the heel region, a sole, and a crown. In many embodiments, the crown comprises an upper region comprising a top rail, and a lower region. In some embodiments, a cavity is located below the top rail, is located above the lower region of the crown, and is defined at least in part by the upper and lower regions of the crown. In many embodiments, the cavity comprises a top wall, a back wall, a bottom incline, a back

cavity angle measured between the top and back walls of the cavity, and at least one channel.

Other embodiments include a method for manufacturing a golf club head. In many embodiments, the method comprises providing a body. The body having a strikeface, a heel region, a toe region opposite the heel region, a sole, and a crown. The crown comprises an upper region comprising a top rail and a lower region. In some embodiments, a cavity is located below the top rail, above the lower region of the crown, and is defined at least in part by the upper and lower regions of the crown. In many embodiments, the cavity comprises a top wall, a back wall adjacent to the top wall, a bottom incline adjacent to the back wall, a back cavity angle measured between the top and back walls of the cavity, and at least one channel.

Other examples and embodiments are further disclosed herein. Such examples and embodiments may be found in the figures, in the claims, and/or in the present description.

I. Golf Club Head with Cascading Sole

Turning to the drawings, FIG. 1 illustrates an embodiment of a golf club head 100. Golf club head 100 can be a wood-type golf club head. For example, golf club head 100 can be a fairway wood-type golf club head or a driver-type golf club head or a hybrid-type golf club head or an iron-type golf club head. Golf club head 100 comprises a body 101. Body 101 comprises a strikeface 112, a heel region 102, a toe region 104, a sole 106, and a crown 108. In FIG. 1, body 101 also comprises a skirt 110 extending between sole 106 and crown 108. In some embodiments, body 101 does not comprise skirt 110 or any skirt. FIG. 18 depicts a front perspective view of a golf club 1800 according to an embodiment. In some embodiments, golf club 1800 comprises golf club head 100 and a shaft 190.

In some embodiments, body 101 can comprise stainless steel, titanium, aluminum, a steel alloy (e.g. 455 steel, 475 steel, 431 steel, 17-4 stainless steel, maraging steel), a titanium alloy (e.g. Ti 7-4, Ti 6-4, T-9S), an aluminum alloy, or a composite material. In some embodiments, strikeface 112 can comprise stainless steel, titanium, aluminum, a steel alloy (e.g. 455 steel, 475 steel, 431 steel, 17-4 stainless steel, maraging steel), a titanium alloy (e.g. Ti 7-4, Ti 6-4, T-9S), an aluminum alloy, or a composite material. In some embodiments, body 101 can comprise the same material as strikeface 112. In some embodiments, body 101 can comprise a different material than strikeface 112.

FIG. 2 illustrates a cross-section of golf club head 100 along the cross-sectional line II-II in FIG. 1, according to one embodiment. FIG. 2 shows an internal radius transition 210 from strikeface 112 to sole 106, according to an embodiment. Internal radius transition 210 can comprise a smooth transition, or internal radius transition 210 can comprise a cascading sole of at least two tiers or levels of thickness. For example, internal radius transition 210 can comprise a cascading sole having 2, 3, 4, 5, 6, or 7 tiers. In some embodiments, internal radius transition can provide more bending of strikeface 112. In some examples, the increase in bending or deflection of strikeface 112 can allow approximately 1% to approximately 3% more energy from the deflection of strikeface 112.

In many embodiments, internal radius transition 210 is not visible from an exterior of golf club head 100. FIG. 2 also shows a top internal radius transition 260 from strikeface 112 to crown 108. In some embodiments, top internal radius transition 260 can comprise a smooth transition, while in other embodiments, top internal radius transition 260 can comprise at least two tiers or levels of thickness. For example, top internal radius transition 260 can comprise 2,

3, 4, 5, 6, or 7 tiers or levels of thickness. In some embodiments, golf club head **100** also can have an internal sole thickness **220**. Internal sole thickness **220** can be thicker than the smallest thickness of internal radius transition **210**. In many embodiments, internal sole thickness **220** also is thicker than an adjacent tier or a final tier in internal radius transition **210**. In some embodiments, internal sole thickness **220** can be thicker than all of internal radius transition **210**.

In some embodiments, internal radius transition **210** can be similar to the sole front section and/or the weight distribution channels as described in U.S. Pat. No. 8,579,728, entitled Golf Club Heads with Weight Redistribution Channels and Related Methods, which is incorporated by reference herein.

In some embodiments, the golf club head can comprise a cascading transition region, tiered transition region or internal radius transition from the strikeface to at least one of a crown, a heel, a toe, a sole, or a skirt. In some embodiments, the golf club head can comprise a single, continuous tiered transition region ring around a circumference of perimeter of the golf club head, for example a tiered transition region ring from the strikeface to each of the crown, the toe region, the heel region, and the sole region. In other embodiments, the golf club head comprises a tiered transition region only at the crown and/or at the sole. In some embodiments, the golf club head comprises a tiered transition region only at the toe region and/or at the heel region. In other examples, the tiered transition region is only located from the strikeface to the skirt. In other embodiments, the golf club head comprises separate or individual tiered transition regions from the strikeface to the toe region of the crown, the heel region of the crown, the toe region of the sole, and/or the heel region of the sole.

FIG. 3 depicts a view of an internal radius transition **310** of a golf club head **300** that is similar to the golf club head of FIG. 1, along a cross-sectional line similar to the cross-sectional line II-II in FIG. 1, according to another embodiment. FIG. 4 depicts a view of an internal radius transition **410** of a golf club head **400** that is similar to the golf club head of FIG. 1, along a cross-sectional line similar to the cross-sectional line II-II in FIG. 1, according to another embodiment. FIG. 5 depicts a view of an internal radius transition **510** of a golf club head **500** that is similar to the golf club head of FIG. 1, along a cross-sectional line similar to the cross-sectional line II-II in FIG. 1, according to another embodiment.

As shown in FIG. 3, internal radius transition **310** can be similar to internal radius transition **210** (FIG. 2) and golf club head **300** can be similar to golf club head **100** (FIGS. 1 and 2). Internal radius transition **310** comprises a first tier **315** having a first thickness, and a second tier **317** having a second thickness. In many embodiments, the thickness of each tier is substantially constant. For example, the first thickness of first tier **315** can comprise a first substantially constant thickness, and the second thickness of second tier **317** can comprise a second substantially constant thickness. In other embodiments, first tier **315** can comprise a first slope, wherein the first thickness of first tier **315** is thicker closer to strikeface **312** and thinner closer to a tier transition region **316**. Tier transition region **316** can comprise a tier slope that is steeper than the first slope of first tier **315**. Tier transition region **316** can be linearly sloped at an angle less than 90 degrees to transition from first tier **315** to second tier **317**. In other embodiments, tier transition region **316** can comprise an approximately 90 degree step, as shown in tier transition regions **516** and **518** of FIG. 5. Tier transition region **516** (FIG. 5) and **518** (FIG. 5) can be

similar to tier transition region **316** (FIG. 3), and tier transition regions **416** (FIG. 4) and **418** (FIG. 4).

As shown in FIG. 4, in some embodiments, each tiered transition **316**, **416**, **418**, **516**, **518** can include a first arcuate surface **420** and a second arcuate surface **422**. The first arcuate surface **420** has a first radius of curvature and the second arcuate surface **422** has a second radius of curvature. The first radius of curvature and the second radius of curvature of each tiered transition **316**, **416**, **418**, **516**, **518** can be the same, or the first radius of curvature and the second radius of curvature of each tiered transition **316**, **416**, **418**, **516**, **518** can be different. For example, the first radius of curvature of the first arcuate surface **420** can be the same as the second radius of curvature of the first arcuate surface **420**, the first radius of curvature of the first arcuate surface **420** can be less than the second radius of curvature of the first arcuate surface **420**, or the first radius of curvature of the first arcuate surface **420** can be greater than the second radius of curvature of the first arcuate surface **420**. For further example, the first radius of curvature of the second arcuate surface **422** can be the same as the second radius of curvature of the second arcuate surface **422**, the first radius of curvature of the second arcuate surface **422** can be less than the second radius of curvature of the second arcuate surface **422**, or the first radius of curvature of the second arcuate surface **422** can be greater than the second radius of curvature of the second arcuate surface **422**.

Further, each of the tiered transitions **316**, **416**, **418**, **516**, **518** can have the same first radius of curvature or a different first radius of curvature, and each of the tiered transitions **316**, **416**, **418**, **516**, **518** can have the same second radius of curvature or a different second radius of curvature. For example, the first radius of curvature of the first arcuate surface **420** can be the same as the first radius of curvature of the second arcuate surface **422**, the first radius of curvature of the first arcuate surface **420** can be less than the first radius of curvature of the second arcuate surface **422**, or the first radius of curvature of the first arcuate surface **420** can be greater than the first radius of curvature of the second arcuate surface **422**. For further example, the second radius of curvature of the first arcuate surface **420** can be the same as the second radius of curvature of the second arcuate surface **422**, the second radius of curvature of the first arcuate surface **420** can be less than the second radius of curvature of the second arcuate surface **422**, or the second radius of curvature of the first arcuate surface **420** can be greater than the second radius of curvature of the second arcuate surface **422**.

The internal radius transition features (e.g. internal tier transition **310**, FIG. 3) can change where a peak bending of a golf club head occurs. The tiered transition region can create a "plastic hinge" at the peak bending, promoting more localized deformation due to impact with the golf ball. In many embodiments, the buckling process starts at the location of the peak bending and the golf club head is optimized to stay just under the critical buckling threshold. The intentional plastic hinge allows the club to flex more in the crown and sole direction. Intentional Plastic Hinge allows control over exactly where and how much the crown and sole will flex by using the tiered features.

Using the internal radius transition, the stress of the golf club head can be distributed across a larger volume of material, thus lowering the localized peak stress. In many embodiments, the additional flex from crown to sole allows the face to bend further based on the same loading. This additional flex can generate more stress and bending in the face of the club to create more spring energy. An increase in

spring energy can be stored in the golf club head due to an impact with the golf ball. In many embodiments, the additional spring energy will help to increase ball speed. In some embodiments, the internal radius transition can create more overall bending in the golf club head, which also can lead to more ball speed. Higher ball speeds across the strikeface can result in better distance control. In some embodiments, the golf club head with internal radius transition features can store approximately 4% to approximately 6% more energy, which can then be returned to the golf ball.

Returning to FIG. 3, internal radius transition 310 can change where a peak bending 350 of the sole of golf club head 300 occurs. In addition, internal radius transition 310 can engage more of the body of club head 300 in the bending process on impact from a golf ball. In some embodiments, first tier 315 and second tier 317 allow some of the stress created by an impact of strikeface 312 with the golf ball to build up on each tier. This structure can prevent the stress from collecting primarily at the thinnest section of the sole to increase the reliability and durability of golf club head 300. In many embodiments, this structure creates a plastic hinge opposite the strikeface end of internal radius transition 310 and promotes more localized deformation at the plastic hinge location. In many embodiments, the plastic hinge can be located at the peak bending, for example, peak bending 350. This structure also can allow for the storage of more potential energy, for example, in the crown and/or the sole. In some embodiments, body 301 can experience an increase of approximately 4% to approximately 7% in flex or bending in the crown to sole direction at the sole and/or the crown. The additional flex in the crown to sole direction at the sole and/or the crown can allow strikeface 312 to bend further on the same loading or impact by the golf ball. Therefore, this structure can create more stress and bending in strikeface 312 of golf club head 300 that can be transferred to the ball on impact with the strikeface 312.

In some embodiments, each tier comprises an approximately constant thickness throughout the tier. In many embodiments, first tier 315 is thicker than second tier 317. In some embodiments of a driver-type golf club head, first tier 315 can be approximately 0.030 inch (0.076 cm) to approximately 0.060 inch (0.152 cm) thick, or approximately 0.040 inch (0.102 cm) to approximately 0.050 inch (0.127 cm) thick, and second tier 317 can be approximately 0.020 inch (0.051 cm) to approximately 0.050 inch thick (0.127 cm), or approximately 0.030 inch (0.076 cm) to approximately 0.040 inch (0.102 cm) thick. In some embodiments of a fairway wood-type golf club head, first tier 315 can be approximately 0.035 inch (0.089 cm) to approximately 0.065 inch (0.165 cm) thick, or approximately 0.045 inch (0.114 cm) to approximately 0.055 inch (0.140 cm) thick, and second tier 317 can be approximately 0.025 inch (0.064 cm) to approximately 0.055 inch (0.140 cm) thick, or approximately 0.035 inch (0.089 cm) to approximately 0.045 inch (0.114 cm) thick. In some embodiments of a hybrid-type golf club head, first tier 315 can be approximately 0.050 inch (0.127 cm) to approximately 0.080 inch (0.203 cm) thick, or approximately 0.060 inch (0.152 cm) to approximately 0.070 inch thick (0.178 cm), and second tier 317 can be approximately 0.040 inch (0.102 cm) to approximately 0.070 inch (0.178 cm) thick, or approximately 0.050 inch (0.127 cm) to approximately 0.060 inch (0.152 cm) thick. In many embodiments of an iron-type golf club head, the first tier 315 can be approximately 0.055 inch (0.140 cm) to approximately 0.085 inch (0.216 cm) thick, or approximately 0.060 inch (0.152 cm) to approximately 0.080 inch thick (0.203 cm), and the second

tier 317 can be approximately 0.045 inch (0.114 cm) to approximately 0.075 inch (0.191 cm) thick, or approximately 0.050 inch (0.127 cm) to approximately 0.070 inch (0.178 cm) thick.

In other embodiments, such as shown in FIG. 4, internal radius transition 410 can have more than 2 tiers. For example, internal radius transition 410 can have 2, 3, 4, 5, 6, or 7 tiers. A three tier internal radius transition 410 can be similar to internal radius transition 310 (FIG. 3) and has a first tier 415, a second tier 417, and a third tier 419. First tier 415 can be similar to first tier 315 in FIG. 3, and second tier 417 can be similar to second tier 317. In many embodiments, a peak bending 450 can occur further back from strikeface 412 as more tiers are added to the internal radius transition.

In many embodiments, second tier 417 is thicker than third tier 419. In some embodiments of a driver-type golf club head, third tier 419 is approximately 0.010 inch to approximately 0.040 inch (0.102 cm) thick, or approximately 0.020 inch (0.051 cm) to approximately 0.030 inch (0.076 cm) thick. In some embodiments of a fairway wood-type golf club head, third tier 419 is approximately 0.015 inch (0.038 cm) to approximately 0.045 inch (0.114 cm) thick, or approximately 0.025 inch (0.064 cm) to approximately 0.035 inch (0.089 cm) thick. In some embodiments of a hybrid-type golf club head, third tier 419 is approximately 0.030 inch (0.076 cm) to approximately 0.060 inch (0.152 cm) thick, or approximately 0.040 inch (0.102 cm) to approximately 0.050 inch (0.127 cm) thick. In some embodiments of an iron-type club head the third tier 419 is approximately 0.030 inch (0.076 cm) to approximately 0.060 inch (0.152 cm) thick, or approximately 0.035 inch (0.089 cm) to approximately 0.055 inch (0.140 cm) thick.

Meanwhile, referring to FIG. 5, in some embodiments of a driver-type golf club head, first tier 515 can be approximately 0.045 inch (0.114 cm) thick; second tier 517 can be approximately 0.035 inch (0.089 cm) thick; and third tier 519 can be approximately 0.025 inch (0.064 cm) thick. In some embodiments of a fairway wood-type golf club head, first tier 515 can be approximately 0.051 inch (0.130 cm) thick; second tier 517 can be approximately 0.039 inch (0.099 cm) thick; and third tier 519 can be approximately 0.030 inch (0.076 cm) thick. In some embodiments of a hybrid-type golf club head, first tier 515 can be approximately 0.067 inch (0.170 cm) thick; second tier 517 can be approximately 0.054 inch (0.137 cm) thick; and third tier 519 can be approximately 0.045 inch (0.114 cm) thick. In some embodiments of an iron-type club head, the first tier 515 can be approximately 0.067 inch (0.170 cm) thick; the second tier can be approximately 0.057 inch (0.145 cm) thick; and the third tier 519 can be approximately 0.042 inch (0.107 cm) thick.

In some embodiments, first tiers 315, 415, 515 in FIGS. 3, 4, and 5, respectively, can have a first tier length that is approximately equal to a second tier length of second tiers 317, 417, 517 in FIGS. 3, 4, and 5, respectively. In some embodiments, the first tier length of first tiers 315, 415, 515 in FIGS. 3, 4, and 5, respectively, can have a first tier length that is longer than the second tier length of second tiers 317, 417, 517. In other embodiments, the second tier length of second tiers 417, 517 in FIGS. 4 and 5, respectively, can be approximately equal to a third tier length of third tiers 419, 519 in FIGS. 4 and 5, respectively. In some embodiments, the second tier length of second tiers 417, 517 in FIGS. 4 and 5, respectively, can be longer than the third tier length of third tiers 419, 519 in FIGS. 4 and 5, respectively. In other embodiments, the second tier length of second tiers 417, 517

in FIGS. 4 and 5, respectively, can be shorter than the third tier length of third tiers 419, 519 in FIGS. 4 and 5, respectively.

Referring to FIGS. 3, 4, and 5, in some embodiments of a fairway wood-type golf club head or a driver-type golf club head or a hybrid-type golf club head, the first tiers 315, 415, 515 can have first tier lengths of approximately 0.05 inch (0.127 cm) to approximately 0.80 inch (2.03 cm); the second tiers 317, 417, 517 can have second tier lengths of approximately 0.03 inch (0.076 cm) to approximately 0.60 inch (1.52 cm); and the third tiers 419, 519 can have third tier lengths of approximately 0.04 inch (0.102 cm) to approximately 0.70 inch (1.78 cm). In some embodiments of an iron-type golf club head, the first tiers 315, 415, 515 can have first tier lengths of approximately 0.03 inch (0.076 cm) to approximately 0.30 inch (0.762 cm); the second tiers 317, 417, 517 can have second tier lengths of approximately 0.04 inch (0.102 cm) to approximately 0.40 inch (1.02 cm); and the third tiers 419, 519 can have third tier lengths of approximately 0.05 inch (0.127 cm) to approximately 0.50 inch (1.27 cm).

As shown in FIGS. 3, 4, and 5, in some embodiments, the first and the second arcuate surface of tiered transitions 316, 416, 516 can have first and second radii of curvatures that are at least two times larger than the difference between the first thickness T_1 and the second thickness T_2 of the first tier 315, 415, 515, and the second tier 317, 417, 517, respectively. In one embodiment, the first and the second arcuate surface of tiered transitions 316, 416, 516 has a first and a second radius of curvature that are approximately 6.5 times larger than the difference between the first thicknesses T_1 and the second thickness T_2 of the first tier 315, 415, 515 and the second tier 317, 417, 517, respectively. As shown in FIGS. 4 and 5, in some embodiments, the first and the second arcuate surface of tiered transitions 418, 518 can have first and second radii of curvatures that are at least two times larger than the difference between the second thickness T_2 and the third thickness T_3 of the second tier 417, 517 and the third tier 419, 519, respectively. In one embodiment, the first and the second arcuate surface of tiered transitions 418, 518 has a first and a second radius of curvature that are approximately 6.5 times larger than the difference between the second thicknesses T_2 and the third thickness T_3 of the second tier 417, 517 and the third tier 419, 519, respectively.

Some embodiments, such as golf club head 300, as shown in FIG. 3, comprise weight pad 330 to lower the center of gravity of golf club head 300. Weight pad 330 comprises a weight pad thickness 331 that is greater than the final tier thickness 321 of the adjacent tier. In this example, the adjacent tier is second tier 317. In many embodiments which comprise weight pad 330, internal sole thickness 320 can be approximately equal to final tier thickness 321. In some embodiments, internal sole thickness 320 can be thicker than final tier thickness 321. In some embodiments, internal sole thickness 320 is thinner than final tier thickness 321.

Some embodiments, such as golf club head 400, as shown in FIG. 4, comprise a rib 440. Rib 440 can be located internal to body 401 and approximately parallel to the strikeface. In many embodiments, rib 440 can be a ridge or bar. In some embodiments, rib 440 can have a rib thickness 441 that is greater than a third tier thickness 421, the thickness of the adjacent tier, or the thickness of the final tier of internal radius transition 410. The purpose for rib 440 is to reinforce the sole of golf club head 400 so that the peak bending of the sole occurs at tier transition region 416 and/or tier transition region 418.

Turning to FIG. 6, in some embodiments, golf club head 600 can comprise a crown internal radius transition 660 at crown 608. Crown internal radius transition 660 can be similar to internal radius transition 310 in FIG. 3, except crown internal radius transition 660 is located at the strikeface to crown transition instead of the strikeface to sole transition. In many embodiments, first tier 615 can be similar to first tiers 315, 415, and/or 515 in FIGS. 3, 4, and 5, respectively; second tier 617 can be similar to second tiers 317, 417, and/or 517 in FIGS. 3, 4, and 5, respectively; third tier 619 can be similar to third tiers 419 and/or 519 in FIGS. 4 and 5, respectively; and tier transition regions 616 and/or 618 can be similar to tier transition regions 316, 416, 516, 418, and/or 518 in FIGS. 3, 4, and 5. Similarly, the crown internal radius transition 660 can have several internal radius transitions to form more than two tiers. For example, the crown internal radius transition 660 can have 2, 3, 4, 5, 6, or 7 tiers.

In FIG. 7, a golf club head 700 can comprise a skirt internal radius transition 780 as shown in FIG. 7. FIG. 7 depicts a cross-sectional view of golf club 700 similar to golf club head 100 (FIG. 1) along a similar cross-sectional line as the cross-sectional line VII-VII in FIG. 1, according to another embodiment. Skirt internal radius transition 780 can be similar to internal radius transition 210 (FIG. 2), and first tier 715 can be similar to first tiers 315, 415, and/or 515 in FIGS. 3, 4, and 5, respectively; second tier 717 can be similar to second tiers 317, 417, and/or 517 in FIGS. 3, 4, and 5; third tier 719 can be similar to third tiers 419 and/or 519 in FIGS. 4 and 5, respectively; and tier transition regions 716 and/or 718 can be similar to tier transition regions 316, 416, 516, 418, and/or 518 in FIGS. 3, 4, and 5. Similarly, skirt internal radius transition 780 can have more than two tiers. For example, skirt internal radius transition 780 can have 2, 3, 4, 5, 6, or 7 tiers. As shown in FIG. 7, golf club head 700 also can comprise a skirt internal radius transition at the other side of strikeface 712. In another embodiment, golf club head 700 can comprise a skirt internal radius transition at a single side of strikeface 712.

FIG. 8 depicts a view of a portion of a golf club head 800 similar to golf club head 400 (FIG. 4), according to an embodiment, and a view of the same area of standard golf club head 850. Standard golf club head 850 comprises a uniform sole thickness 855 from a strikeface 852 to a sole 856, and an internal sole weight 870 that is thicker than a uniform sole thickness 855. Golf club head 800 comprises an internal radius transition 810 similar to internal radius transition 410 (FIG. 4). Internal radius transition 810 can comprise a first tier 815, similar to first tier 415 (FIG. 4), a second tier 817, similar to second tier 417 (FIG. 4), and a third tier 819, similar to third tier 419 (FIG. 4). Internal radius transition 810 also can comprise tier transition regions 816 and 818, similar to tier transition regions 416 (FIG. 4) and 418 (FIG. 4), and internal sole weight 820 that is similar to internal sole weight 870. In many embodiments, at least one of first tier 815, second tier 817, or third tier 819 can be thinner than uniform sole thickness 855. The thinness of the tiers can save weight that can then be redistributed in the club head.

There is a greater dispersion of higher stress over a greater area of sole 806 with internal transition region 810 than sole 856 without the cascading sole. In many embodiments, a general curve of a sole similar to uniform sole thickness 855 can absorb greater particular concentrations of impact force from a golf ball in particular regions, but will not disperse the force over a larger area. The cascading structure (or tiers of varying thickness along the internal radius transition),

such as internal radius transition **810**, however provides a technique to “package” the impact force from the golf ball over a larger area as the undulating or tier structure transfers higher stresses from one internal radius region of particular thickness to the next. In many embodiments, there is a bleeding, overflow, or pooling of the stress over internal radius transition **810** or the cascading thin sole. The greater dispersion of the greater stress force provides a greater recoiling force to the strikeface. The pooling of the stress over internal radius transition **810** also can prevent all of the stress from collecting directly at the thinnest tier. In many embodiments, the tiered features can help distribute the stress along the sole to prevent one large stress riser. Instead, there are multiple stress risers for a more even distribution of the stress. The stresses are extended along the cascading sole, allowing the sole to take on (or absorb) more stress. The stress, however, decreases at the thickest portion of the sole that without the cascading sole experiences the highest level of stress, and provides less spring back force to the strikeface.

An embodiment of a golf club head (e.g. **100**, **300**, **400**, **500**, **600**, or **700**) having the cascading sole was tested compared to a similar control club head devoid of a cascading sole. The club head with the cascading sole showed an increase in ball speed of approximately 0.5-1.5 miles per hour (mph) (0.8-2.4 kilometers per hour, kph), or approximately 0.5-0.9%, compared to the control club head. The increase in ball speed for center impacts was approximately 0.5-1.0 mph (0.8-1.6 kph), and the increase in ball speed for off-center impacts was approximately 1-1.5 mph (1.6-2.4 kph). The club head with the cascading sole further showed an increase in launch angle of approximately 0.1-0.3 degrees, a decrease in spin of approximately 275-315 revolutions per minute (rpm), and an increase in carry distance of approximately 3-6 yards (2.7-5.5 meters) compared to the control club head.

In some embodiments, the crown of a driver-type, hybrid-type, or wood-type golf club head having the cascading sole (e.g. **100**, **300**, **400**, **500**, **600**, or **700**) may further include a first crown thickness (not shown) and a second crown thickness (not shown). The first crown thickness may be positioned on the crown behind the strikeface or crown internal radius transition. The second crown thickness may be positioned on the crown behind the first crown thickness toward the rear of the club head. The first crown thickness is greater than the second crown thickness. Further, the first crown thickness may transition to the second crown thickness gradually according to any profile, or the first crown thickness may transition to the second crown thickness abruptly, such as with a step.

The first crown thickness may comprise any portion of the crown on a front end of the club head. For example, the first crown thickness may comprise 5%, 10%, 15%, 20%, 25%, 30%, 35%, 40%, 45%, 50%, or any other portion of the crown on the front end of the club head. The second crown thickness may comprise any portion of the crown on the rear of the club head. For example, the second crown thickness may comprise 40%, 45%, 50%, 55%, 60%, 65%, 70%, 75%, 80%, or any other portion of the rear of the club head.

The crown thickness may transition between the first crown thickness and the second crown thickness at any position on the crown of the club head, defining a crown thickness transition. The crown thickness transition may be any shape. In the exemplary embodiment, the crown thickness transition defines a bell-shaped curve, similar to the bell-shaped curve in U.S. Pat. No. 7,892,111, which is incorporated herein by reference. The first crown thickness

is positioned on the crown between the strikeface and the bell-shaped curve, and the second crown thickness is positioned on the crown between the bell-shaped curve and the rear of the club head.

In the exemplary embodiment, the first crown thickness is approximately 0.022 inches (0.056 cm) and the second crown thickness is approximately 0.019 inches (0.048 cm) when the golf club head is a fairway wood type golf club head. Further, in the exemplary embodiment, the first crown thickness is approximately 0.024 inches (0.061 cm) and the second crown thickness is approximately 0.019 inches (0.048 inches) when the golf club head is a hybrid type golf club head.

In other embodiments of a fairway wood or hybrid type golf club head, the first crown thickness may be less than approximately 0.029 (0.074), 0.028 (0.071), 0.027 (0.069), 0.026 (0.066), 0.025 (0.064), 0.024 (0.061), 0.023 (0.058), 0.022 (0.056), 0.021 (0.053), 0.020 (0.051), 0.019 (0.048), 0.018 (0.046), or 0.017 (0.043) inches (cm), and the second crown thickness may be less than approximately 0.024 (0.061), 0.023 (0.058), 0.022 (0.056), 0.021 (0.053), 0.020 (0.051), 0.019 (0.048), 0.018 (0.046), 0.017 (0.043), 0.016 (0.041), 0.015 (0.038), 0.014 (0.036), 0.013 (0.033), or 0.012 (0.031) inches (cm).

The crown internal radius transition dissipates and/or reduces stresses on the crown of the club head, thereby allowing the first and the second crown thickness to be reduced compared to previous designs. In the exemplary embodiment, the first crown thickness is reduced by approximately 17.2-24.1%, and the second crown thickness is reduced by approximately 20.8% compared to previous designs. Reducing the first and the second crown thickness allows the center of gravity of the club head to be lowered (positioned closer to the sole) compared to previous designs. The lowered center of gravity of the club head improves the performance characteristics of the club head by reducing gearing and spin on the ball.

Turning to FIG. 9, various embodiments of golf club heads with tiered internal thin sections include a method **900** for manufacturing a golf club head. Method **900** comprises providing a body (block **910**). The body comprises a strikeface, a heel region, a toe region opposite the heel region, a sole, and a crown. In some embodiments, the body further comprises a skirt extending from the crown to the sole. Method **900** further comprises providing an internal radius transition region from the strikeface to at least one of the sole, the crown, or the skirt (block **920**). Method **900** further comprises providing a first tier of the internal radius transition region (block **930**), providing a second tier of the internal transition region (block **940**), and providing a tier transition region between the first tier and the second tier of the internal transition region (block **950**). In some embodiments, each of blocks **910**, **920**, **930**, **940**, and **950** can be performed simultaneously with each other such as by casting the body of a club head. In other embodiments, one or more of blocks **920**, **930**, **940**, and/or **950** can be performed after block **910** through a machining process, as an example.

II. Golf Club Head with Back Cavity

In one embodiment, the golf club head has a back cavity located in an upper crown area of the golf club. In many embodiments, the back cavity can provide a box spring affect when striking a golf ball. The back cavity can be combined with varying thicknesses of the internal radius of the sole of the club head (cascading sole) to provide a spring like effect.

Some embodiments are directed to a club head (hybrid or fairway wood or iron with hollow design) that features a

hollowed construction club head that provides a more “iron-like” look and feel. In some embodiments, the golf club head can feature a flat strikeface and iron-like profile, which can provide improved workability and accuracy, similar to an iron. A back cavity located below a top rail and along the upper crown of the club head has been designed for hybrids, fairway woods and irons with a hollow construction. The back cavity may be a full channel from the heel to the toe just below the top rail and along the upper crown or back portion of the club head. The top rail and the cavity may be any design. In some embodiments, the cavity is angled at approximately 90 degrees and provides a targeted hinge point in the crown region of the golf club head. This hinge or buckling region enables the top rail to absorb more of the impact force over a wider volumetric area causing the cavity and the top rail to act as a springboard by returning more recoiled force back to the strikeface as it returns to its original orientation thereby imparting more force into the ball. This greater club face deflection by the cavity design can lead to less spin, a higher loft angle of the golf ball upon impact, and greater ball speed with the same club speed over standard golf club heads.

In a standard hybrid club head, the top rail and upper crown regions do not have a cavity of this design. In comparison to the present disclosure, there is less club strikeface bending or deflection in such a standard hybrid club head. Standard hybrids are unable to have as great a spring-back effect because less energy is transferred to the top rail of the club due to the lack of a cavity. The disclosed golf club head with back cavity allows more of the impact force of the golf ball to be absorbed and then returned to the strikeface. In many embodiments, the angle of the cavity can provide a buckling point, or plastic hinge, or targeted hinge, for the strikeface to deflect more over the standard golf club.

The recoiling effect of the cavity on the strikeface provides: (1) a higher golf ball speed relative to the same club head speed of a club head with an upper crown cavity (or back cavity) and one without, due in part to the spring effect that is transferred from the hinged region to the strikeface to the ball; (2) less spin of the golf ball after impact with the club, due in part to the hinge point above the cavity counters more force being absorbed by the club and instead transfers more force to the ball thereby preventing the ball from spinning backward off the strikeface; (3) a higher loft angle to the golf ball upon impact, due to the hinge and strikeface acting as a diving board or catapult to the ball. In some embodiments, the cavity may provide an increase in ball speed of approximately 1.0-1.2%, and an increase in launch angle of approximately 0.4-0.7 degrees.

Turning back to the drawings, FIG. 10 illustrates a back toe-side perspective view of an embodiment of golf club head 1000 and FIG. 11 illustrates a back heel-side perspective view of golf club head 1000 according to the embodiment of FIG. 10. Golf club head 1000 can be a hybrid-type golf club head. In other embodiments, golf club head 1000 can be an iron-type golf club head or a fairway wood-type golf club head. In many embodiments, golf club head 1000 does not include a badge or a custom tuning port.

The club head 1000 can comprise a volume between 39 cubic centimeters (cc) and 93 cc. For example, in some embodiments, the volume of the club head 1000 can be greater than 39 cc, greater than 40 cc, greater than 45 cc, greater than 50 cc, greater than 55 cc, greater than 60 cc, greater than 65 cc, greater than 70 cc, greater than 75 cc, greater than 80 cc, greater than 85 cc, or greater than 90 cc. In many embodiments, the volume of the club head 1000 can be measured by submerging the club head and measuring the

displaced volume of liquid. In many embodiments, the volume of the club head 1000 can be measured before a bore hole is created in the hosel.

Golf club head 1000 comprises a body 1001. In many embodiments, the body is hollow. In some embodiments, the body is at least partially hollow. The hollow portion within the body forms an enclosed internal void or cavity located behind the strikeface. The enclosed void can have a volume between 10 cc and 56 cc. In some embodiments, the void within the body can be greater than 10 cc, greater than 15 cc, greater than 20 cc, greater than 25 cc, greater than 30 cc, greater than 35 cc, greater than 40 cc, greater than 45 cc, greater than 50 cc, or greater than 56 cc. For example, the void can have a volume between 12-16 cc, between 16-20 cc, between 20-26 cc, between 26-35 cc, between 35-40 cc, between 40-48 cc, between 48-56 cc, between 13.3-16.3 cc, between 20.2-25.6, between 25.4-25.8, between 36.7-38.3 cc, or between 41.9-46.3 cc.

In some embodiments, the void can comprise between 20% and 70% of the total club head volume. For example, the void can comprise between 20% and 30%, between 30% and 40%, between 35% and 45%, between 40% and 50%, between 45% and 55%, between 50% and 60%, between 55% and 65%, or between 60% and 70% of the total head volume.

Body 1001 comprises a strikeface 1012, a heel region 1002, a toe region 1004 opposite heel region 1002, a sole 1006, and a crown 1008. Crown 1008 comprises an upper region 1011 and a lower region 1013. As seen in FIG. 12, the upper region 1011 can be above a second inflection point 1086, and the lower region 1013 can be below the second inflection point 1086. The upper region 1011 comprises a top rail 1015. The top rail 1015 begins at a top edge of the strikeface 1012 and extends to a rear wall 1023. The top rail 1015 can extend in a direction generally orthogonal to the strikeface (e.g. at an angle between 75 and 105 degrees from the strikeface). The rear wall 1023 can extend in a direction generally parallel to the strikeface (e.g. at an angle between 0 and 30 degrees from the strikeface). Further, the top rail 1015 extends along the top of the golf club head 1000 from the toe region 1004 to the heel region 1002. In some embodiments, top rail 1015 can be a flatter and taller top rail or skirt. The flatter and taller top rail can account for mishits on strikeface 1012 to increase playability off the tee.

In some embodiments, body 1001 can comprise stainless steel, titanium, aluminum, a steel alloy (e.g. 455 steel, 475 steel, 431 steel, 17-4 stainless steel, maraging steel), a titanium alloy (e.g. Ti 7-4, Ti 6-4, T-9S), an aluminum alloy, or a composite material. In some embodiments, strikeface 1012 can comprise stainless steel, titanium, aluminum, a steel alloy (e.g. 455 steel, 475 steel, 431 steel, 17-4 stainless steel, maraging steel), a titanium alloy (e.g. Ti 7-4, Ti 6-4, T-9S), an aluminum alloy, or a composite material. In some embodiments, body 1001 can comprise the same material as strikeface 1012. In some embodiments, body 1001 can comprise a different material than strikeface 1012.

The hollow void of the body 1001 can be located behind the strikeface 1012. In some embodiments, the void covers or is positioned behind between 60% and 100% of the back of the strikeface 1012. For example, the void can cover between 60% and 70%, between 70% and 80%, between 80% and 90%, or between 90% and 100% of the back of the strikeface 1012. In some embodiments, the void is located behind 100% of the strikeface and behind a portion of the heel region 1002. In some embodiments, the void is located behind 100% of the strikeface and behind a portion of the toe region 1004. From the back of the strikeface 1012, the

hollow void extends towards the rear of the body **1001**, and is contained on all sides so that it does not open to the exterior of the club head **1000**. Vertically, the void extends from the top rail **1015** to the sole **1006**. The void further extends horizontally from the back of the strikeface **1012** to one or more rear surfaces, as described below. The void can extend horizontally from the heel region **1002** to the toe region **1004**, at any location between the sole **1006** and the top rail **1015**. In some embodiments, the void can extend approximately halfway from the heel region **1002** to the toe region **1004**, at any location between the sole **1006** and the top rail **1015**. In some embodiments, the length of the void, measured horizontally between the heel and the toe, can be approximately 10% to 90% of the length of the body **1001**, at any location between the sole **1006** and the top rail **1015**.

The strikeface **1012** of the golf club head **1000** can have a thickness (not depicted), measured from the inside surface of the strikeface **1012** to the outside surface of the strikeface **1012**. In many embodiments, the thickness of the strikeface **1012** can be between 0.060 and 0.150 inch. In some embodiments, the thickness of the strikeface **1012** can be between 0.080 and 0.120 inch. In some embodiments, the thickness of the strikeface **1012** can be greater than 0.060 inch, greater than 0.070 inch, greater than 0.080 inch, greater than 0.090 inch, or greater than 0.100 inch. In some embodiments, the thickness of the strikeface **1012** can vary. In other embodiments, the thickness of the strikeface **1012** can be substantially constant.

As depicted in FIG. **13**, the top rail **1015** of golf club head **1000** can have a thickness **1052**, measured from the inside surface of the top rail **1015** to the outside surface of the top rail **1015**. In many embodiments, the top rail **1015** of the club head **1000** can be thinner than the top rail of typical iron type club heads.

In many embodiments, the thickness of the top rail **1015** can be between 0.020 and 0.070 inch. In some embodiments, the thickness of the top rail **1015** can be between 0.035 and 0.065 inch. In some embodiments, the thickness of the top rail **1015** can be between 0.040 and 0.050 inch. Further, in many embodiments, the thickness of the top rail **1015** can be less than 0.070 inch, less than 0.065 inch, less than 0.060 inch, less than 0.055 inch, less than 0.050 inch, less than 0.045 inch, less than 0.040 inch, less than 0.035 inch, less than 0.030 inch, or less than 0.025 inch.

In many embodiments, the top rail thickness **1052** can be less than the thickness of at least a portion of the strikeface **1012**. In these embodiments, the strikeface **1012** thickness can be measured at any location across the strikeface (e.g. at the center, near the heel, near the toe, near the top rail, near the sole, or at a periphery of the strikeface **1012**).

In many embodiments, a cavity **1030** is located below top rail **1015** and at the rear portion of the body **1001**. The cavity **1030** is an external cavity that is recessed in towards the center of the golf club head. The external cavity is visible when viewing the rear portion or backside of the club head **1000**. In many embodiments, cavity **1030** comprises a top rail box spring design. In many embodiments, top rail **1015** and cavity **1030** provide an increase in the overall bending of strikeface **1012**. The cavity **1030** enables bending of the strikeface **1012** to temporarily store elastic potential energy during impact, which is then returned to the strikeface to impart more energy to the golf ball, thereby increasing ball speed and travel distance. In some embodiments, the bending of strikeface **1012** can allow for an approximately 2% to approximately 5% increase of energy transfer to a golf ball on impact. The cavity **1030** allows for the strikeface **1012** to be thinner and allows additional overall bending. For some

fairway wood-type golf club head embodiments, cavity **1030** can be a reverse scoop or indentation of crown **1008** with greater thickness toward sole **1006**.

Referring to FIG. **10**, in some embodiments, golf club head **1000** can further comprise an insert **1062** at lower region **1013** of crown **1008** towards toe region **1004**. Some embodiments comprise an internal weight at sole **1006**. In many embodiments, insert **1062** may be comprised of tungsten or some other high density material. In many embodiments, the insert shifts the center of gravity (CG) back from strikeface **1012** by approximately 0.04 inch (1 mm) to 0.10 inch (2.5 mm) and provides a 3.5% to 5.5% increase in launch angle, which can lead to an increase of playability off the tee and high or low mishits.

In many embodiments, the CG is in lower region **1013** of crown **1008**, close to the intersection of toe region **1004** and sole **1006**. In some embodiments, the CG of golf club head **1000** is 0.597 inches along the CGy plane and 0.541 inches along the CGz plane. For the moment of inertia, I_{xx} , there was a 20.5% increase over the G30 iron and a 28% increase over the Rapture DI by golf club head **1000**. For I_{yy} , there was a 1.7% increase over the G30 iron and a 22% increase over Rapture DI.

In some embodiments, approximately 3 grams (g) to approximately 4 g is added to top rail **1015**. In most embodiments, the overall mass of golf club head **1000** remains the same. In some embodiments, mass can be removed from sole **1006** or toe region **1004** to offset the addition of mass to top rail **1015**. In some embodiments, adding the approximately 3 g to approximately 4 g of mass to top rail **1015** can assist in the golf club head resisting turning. In some embodiments, the CG of the golf club head is slightly raised.

FIG. **12** illustrates a cross-section of golf club head **1000** along the cross-sectional line XII-XII in FIG. **10**, according to one embodiment. As seen in FIG. **12**, strikeface **1012** comprises a high region **1076**, a middle region **1074**, and a low region **1072**. In many embodiments, upper region **1011** of crown **1008** comprises a rear wall **1023**, a top wall **1017** of cavity **1030** below and adjacent to rear wall **1023**, and a back wall **1019** of cavity **1030** below and adjacent to top wall **1017**.

In some embodiments, a height **1280** of rear wall **1023** of the upper region **1011** of crown **1008** can be approximately 0.125 inch (0.318 cm) to approximately 0.75 inch (1.91 cm), or approximately 0.150 inch (0.381 cm) to approximately 0.400 inch (1.02 cm). For example, in some embodiments, the height **1280** of rear wall **1023** of the upper region **1011** of crown **1008** can be approximately 0.175 inch (0.445 cm), 0.275 inch (0.699 cm), 0.375 inch (0.953 cm), 0.475 inch (1.21 cm), 0.575 inch (1.46 cm), or 0.675 inch (1.71 cm). In some embodiments, the height **1280** of rear wall **1023** of the upper region **1011** of crown **1008** can be approximately 5% to approximately 25% of the height of golf club head **1000**. In some embodiments, the length of top rail **1015**, measured from heel region **1002** to toe region **1004**, can be approximately 70% to approximately 95% of the length of golf club head **1000**.

The height **1280** of rear wall **1023** of the upper region **1011** of crown **1008**, as described herein, allows cavity **1030** to absorb at least a portion of the stress on strikeface **1012** during impact with a golf ball. A golf club head having a rear wall height greater than the rear wall height **1280** described herein would absorb less stress (and allow less strikeface deflection) on impact than the golf club head **1000** described herein, due to increased dispersion of the impact stress along the top rail prior to reaching the cavity.

The cavity **1030** is located on an exterior surface of the club head body **1001**. In some embodiments, cavity **1030** is located above the lower region **1013** of crown **1008** and is defined at least in part by upper region **1011** and lower region **1013** of crown **1008**. The cavity **1030** comprises a top wall **1017**, a back wall **1019**, and a bottom incline **1021**. A first inflection point **1082** is located between top wall **1017** of cavity **1030** and rear wall **1019** of cavity. The second inflection point **1086** is located between rear wall **1019** of cavity **1030** and bottom incline **1021**.

In some embodiments, the height of back wall **1019**, measured from first inflection point **1082** to second inflection point **1086**, can be approximately 0.010 inch (0.25 mm) to approximately 0.138 inch (3.5 mm), or approximately 0.010 inch (0.25 mm) to approximately 0.059 inch (1.5 mm). For example, the height of back wall **1019** can be approximately 0.01 inch (0.25 mm), 0.02 inch (0.5 mm), 0.03 inch (0.75 mm), 0.04 inch (1.0 mm), 0.05 inch (1.25 mm), 0.06 inch (1.5 mm), 0.07 inch (1.75 mm), 0.08 inch (2.0 mm), 0.09 inch (2.25 mm), 0.10 inch (2.5 mm), 0.11 inch (2.75 mm), 0.12 inch (3.0 mm), 0.13 inch (3.25 mm), or 0.14 inch (3.5 mm). In many embodiments, an apex of top wall **1017** can be approximately 0.125 inch (0.318 cm) to approximately 1.25 inches (3.18 cm) or approximately 0.25 inch (0.635 cm) to approximately 1.25 inches (3.18 cm) below an apex of top rail **1015**. For example, the apex of top wall **1017** can be approximately 0.125 inch (0.318 cm), 0.25 inch (0.635 cm), 0.375 inch (0.953 cm), 0.5 inch (1.27 cm), 0.625 inch (1.59 cm), 0.75 inch (1.91 cm), 0.825 inch (2.10 cm), 1.0 inch (2.54 cm), 1.125 inches (2.88 cm), or 1.25 inches (3.18 cm) below the apex of top rail **1015**.

In many embodiments, back wall **1019** of cavity **1030** can be substantially parallel to strikeface **1012**. In other embodiments, back wall **1019** is not substantially parallel to strikeface **1012**. In many embodiments, top wall **1017** of cavity is angled toward strikeface **1012** when moving toward the first inflection point **1082**. This orientation of top wall **1017** creates a buckling point or hinge point or plastic hinge to direct the stress of impact toward cavity **1030** and allowing increased flexing of strikeface **1012** during impact.

Lower region **1013** of crown **1008** comprises bottom incline **1021**. In many embodiments, the second inflection point **1086**, adjacent to bottom incline **1021**, can be at least approximately 0.25 inch (0.635 cm) to approximately 2.0 inches (5.08 cm), or approximately 0.5 inch (1.27 cm) to approximately 1.5 inches (3.81 cm) below the apex of top rail **1015**. For example, the second inflection point **1086** can be at least approximately 0.25 inch (0.635 cm), 0.5 inch (1.27 cm), 0.75 inch (1.91 cm), 1.0 inch (2.53 cm), 1.25 inches (3.18 cm), 1.5 inches (3.81 cm), 1.75 inches (4.45 cm) or 2.0 inches (5.08 cm) below the apex of top rail **1015**. In some embodiments, the maximum height of the bottom incline, measured from the sole **1006** of the club head **1000** to the second inflection point **1086**, can be at least approximately 0.25 inch (0.635 cm) to approximately 3 inches (7.62 cm), or approximately 0.50 inch (1.27 cm) to approximately 2 inches (5.08 cm) above a lowest point of the sole **1006**. For example, the second inflection point **1086** can be at least approximately 0.25 inch (0.635 cm), 0.375 inch (0.953 cm), 0.5 inch (1.27 cm), 0.625 inch (1.59 cm), 0.75 inch (1.91 cm), 0.825 inch (2.10 cm), 1.0 inch (2.54 cm), 1.125 inches (2.88 cm), 1.25 inches (3.18 cm), 1.375 inches (3.49 cm), 1.5 inches (3.81 cm), 1.625 inches (4.12 cm), 1.75 inches (4.45 cm), 1.875 inches (4.76 cm), 2.0 inches (5.08 cm), 2.125 inches (5.40 cm), 2.25 inches (5.71 cm), 2.375 inches (6.03 cm), 2.5 inches (6.35 cm), 2.625 inches (6.67 cm),

2.75 inches (7.00 cm), 2.875 inches (7.30 cm), or 3.0 inches (7.62 cm) above a lowest point of the sole.

Cavity **1030** further comprises at least one channel **1039** (FIG. 10). In many embodiments, channel **1039** extends from heel region **1002** to toe region **1004**. A channel width **1032** (FIG. 12) can be substantially constant throughout channel **1039**. In some embodiments, channel width **1032** (FIG. 12) can be approximately 0.008 inch (0.2 mm) to approximately 1 inch (25 mm), or approximately 0.008 inch (0.2 mm) to approximately 0.31 inch (8 mm). For example, channel width **1032** can be approximately 0.008 inch (0.2 mm), 0.016 inch (0.4 mm), 0.024 inch (0.6 mm), 0.031 inch (0.8 mm), 0.039 inch (1.0 mm), 0.079 inch (2 mm), 0.12 inch (3 mm), 0.16 inch (4 mm), 0.20 inch (5 mm), 0.24 inch (6 mm), 0.28 inch (7 mm), 0.31 inch (8 mm), 0.39 inch (10 mm), 0.59 inch (15 mm), 0.79 inch (20 mm), or 0.98 inch (25 mm). In other embodiments, a channel toe region width of channel **1039** is smaller than a channel heel region width of channel. In other embodiments, the channel heel region width is smaller than the channel toe region width. In other embodiments, a channel middle region width of channel **1039** can be smaller than at least one of the channel heel region width or the channel toe region width. In other embodiments, the channel middle region width can be greater than at least one of the channel heel region width or the channel toe region width. In some embodiments, channel **1039** is symmetrical. In other embodiments, channel **1039** is non-symmetrical. In other embodiments, channel **1039** can further comprise at least two partial channels. In some embodiments, channel **1039** can comprise a series of partial channels interrupted by one or more bridges. In some embodiments, the one or more bridges can be approximately the same thickness as the thickness of upper region **1011** of crown **1008**.

The channel width **1032**, as described herein, allows absorption of stress from strikeface **1012** on impact. A golf club head having a channel width less than the channel width described herein (e.g. a golf club head with a less pronounced cavity) would allow less stress absorption from the strikeface on impact (due to less material on the upper region **1011** of crown **1008**), and therefore would experience less strikeface deflection than the golf club head **1000** described herein.

In many embodiments, cavity **1030** further comprises a back cavity angle **1035**. Back cavity angle is measured between top wall **1017** and back wall **1019** of cavity **1030**. In many embodiments, back cavity angle **1035** can be approximately 70 degrees to approximately 110 degrees. In some embodiments, back cavity angle **1035** can be approximately 80 degrees to approximately 100 degrees. In some embodiments, back cavity angle **1035** is approximately 70, 75, 80, 85, 90, 95, 100, or 110 degrees. In many embodiments, back cavity angle **1035** provides a buckling point or plastic hinge or targeted hinge at a first inflection point **1082**, upon golf club head **1000** upon impact with a golf ball. In some embodiments, the wall thickness at first inflection point **1082** is thinner than at the top wall **1017** of cavity **1030**.

FIG. 13 illustrates a view of crown **1008** of the cross-section of golf club head **1000** of FIG. 12 alongside a similar cross-section of a golf club head **1200** without a cavity along a similar cross-sectional line XII-XII in FIG. 10. Golf club head **1200** comprises a strikeface **1212** and a crown **1208** with a top rail **1215**, a top rail hinge point **1270**, and a rear wall **1223**, similar to the strikeface **1012**, the crown **1008**, the top rail **1015**, the top rail hinge point **1070**, and the rear wall **1023**, respectively, of golf club head **1000**. The thick-

ness **1252** of the top rail can be similar to the thickness **1052** of the top rail of golf club head **1000**. Golf club head **1200** is an example of a golf club head without a cavity similar to the cavity **1030** of golf club head **1000**.

Referring to FIG. **13**, in many embodiments, golf club head **1000** comprises a rear angle **1040**, a top rail angle **1045**, and a strikeface angle **1050**. Rear angle **1040** is measured from top wall **1017** to rear wall **1023** of upper region **1011**. In many embodiments, rear angle **1040** can be approximately 70 degrees to approximately 110 degrees. In some embodiments, rear angle **1040** is approximately 90 degrees. Top rail angle **1045** is measured from rear wall **1023** of upper region **1011** to top rail **1015**. In many embodiments, top rail angle **1045** can be approximately 35 degrees to approximately 120 degrees or 70 degrees to approximately 110 degrees. In some embodiments, top rail angle **1045** can be approximately 35, 40, 45, 50, 55, 60, 65, 70, 75, 80, 85, 90, 95, 100, 105, 110, 115, or 120 degrees. Strikeface angle **1050** is measured from strikeface **1012** to top rail **1015**. In many embodiments, strikeface angle **1050** can be approximately 70 degrees to approximately 160 degrees or 70 degrees to approximately 110 degrees. In some embodiments, strikeface angle **1050** is approximately 70, 75, 80, 85, 90, 95, 100, 105, 110, 115, 120, 125, 130, 135, 140, 145, 150, 155, or 160 degrees.

Referring to FIG. **13**, in some embodiments, a minimum gap **1090** between strikeface **1012** and back wall **1019** is approximately 0.079 inch (2 mm) to approximately 0.39 inch (10 mm). For example, the minimum gap **1090** between strikeface **1012** and back wall **1019** can be approximately 0.079 inch (2 mm), 0.16 inch (4 mm), 0.24 inch (6 mm), 0.31 inch (8 mm), or 0.39 inch (10 mm). In some embodiments, the minimum gap **1090** between the strikeface **1012** and back wall **1019** is less than approximately 0.55 inch (14 mm), less than approximately 0.47 inch (12 mm), less than approximately 0.39 inch (10 mm), less than approximately 0.31 inch (8 mm), less than approximately 0.24 inch (6 mm), or less than approximately 0.16 inch (4 mm). Further, in some embodiments, a maximum gap between strikeface **1012** and rear wall **1023** of upper region **1011** of golf club head **1000** is greater than minimum gap **1090**. Further still, in some embodiments, a maximum gap between strikeface **1012** and bottom incline **1021** in lower region **1013** of golf club head **1000** is greater than minimum gap **1090** and maximum gap in upper region **1011**.

FIG. **21** illustrates a cross-sectional view of golf club head **1000**, similar to the cross-section of the golf club head **1000** illustrated in FIG. **12**. Golf club head **1000** includes cavity **1030**, upper region **1011**, and lower region **1013**. Upper region **1011** includes upper exterior rear wall **1023**, cavity **1030** includes cavity exterior wall **1025**, and lower region **1013** includes lower exterior wall **1027**. In many embodiments, a maximum upper distance **1092** measured as the perpendicular distance from the strikeface **1012** to the rear wall **1023** of upper region **1011** can be approximately 0.20-0.59 inch (5-15 mm). For example, maximum upper distance **1092** can be approximately 0.20 inch (5 mm), 0.24 inch (6 mm), 0.28 inch (7 mm), 0.31 inch (8 mm), 0.35 inch (9 mm), 0.39 inch (10 mm), 0.43 inch (11 mm), 0.47 inch (12 mm), 0.51 inch (13 mm), 0.55 inch (14 mm), or 0.59 inch (15 mm). Further, a minimum cavity distance **1094** measured as the perpendicular distance from the strikeface **1012** to the cavity exterior wall **1025** can be approximately 0.16-0.47 inch (4-12 mm). For example, minimum cavity distance **1094** can be approximately 0.16 inch (4 mm), 0.20 inch (5 mm), 0.24 inch (6 mm), 0.28 inch (7 mm), 0.31 inch (8 mm), 0.35 inch (9 mm), 0.39 inch (10 mm), 0.43 inch (11

mm), or 0.47 inch (12 mm). Further still, a maximum lower distance **1096** measured as the perpendicular distance from the strikeface **1012** to the lower exterior wall **1027** can be approximately 0.98-1.57 inch (25-40 mm). For example, maximum lower distance **1096** can be approximately 0.98 inch (25 mm), 1.02 inch (26 mm), 1.06 inch (27 mm), 1.10 inch (28 mm), 1.14 inch (29 mm), 1.18 inch (30 mm), 1.22 inch (31 mm), 1.26 inch (32 mm), 1.30 inch (33 mm), 1.34 inch (34 mm), 1.38 inch (35 mm), 1.42 inch (36 mm), 1.46 inch (37 mm), 1.50 inch (38 mm), 1.54 inch (39 mm), 1.57 inch or (40 mm). In many embodiments, maximum lower distance **1096** is greater than maximum upper distance **1092**, and maximum upper distance **1092** is greater than minimum cavity distance **1094**.

In many embodiments, cavity **1030** can provide an increase in golf ball speed over golf club head **1200**, which has a thin top rail **1215** but no cavity, and over standard golf club heads, which have both a thick top rail and no cavity. The cavity **1030** can also reduce the spin rate of standard hybrid club heads, and can increase the launch angle over both the standard hybrid and iron club heads. In many embodiments, the shape of cavity **1030** determines the level of spring and timing of the response of golf club head **1000**. When the golf ball impacts strikeface **1012** of club head **1000** with cavity **1030**, strikeface **1012** springs back like a drum, and crown **1008** bends in a controlled buckle manner. During impact, the top wall **1017** buckles or bows outward, causing the cavity **1030** to absorb and temporarily store some of the energy from the impact which is later transferred back to the strikeface and golf ball to increase ball speed and travel distance.

In many embodiments, top rail **1015** can absorb more stress over greater volumetric space than a top rail in a golf club head without cavity **1030**. The length, depth and width of cavity **1030** can vary. These parameters provide control regarding how much spring back is present in the overall design of club head **1000**.

Upon impact with the golf ball, strikeface **1012** can bend inward at a greater distance than on a golf club without cavity **1030**. In some embodiments, strikeface **1012** has an approximately 10% to approximately 50% greater deflection than a strikeface on a golf club head without cavity **1030**. In some embodiments, strikeface **1012** has an approximately 5% to approximately 40% or approximately 10% to approximately 20% greater deflection than a strikeface on a golf club head without cavity **1030**. For example, strikeface **1012** can have an approximately 5%, 10%, 15%, 20%, 25%, 30%, 35% or 40% greater deflection than a strikeface on a golf club head without cavity **1030**. In many embodiments, there is both a greater distance of retraction by strikeface **1012** due to the hinge and bending of cavity **1030** over a standard strikeface that does not have a back portion of the club without the cavity.

In many embodiments, the face deflection is greater with club head **1000** having cavity **1030**, as a greater buckling occurs along top rail hinge point **1070** upon impact with the golf ball. The rear wall **1023** and the top rail **1015** hinge about the top rail hinge point **1070**. This hinge-like mobility at the top rail hinge point **1070** allows the top rail angle **1045** to change during impact with a golf ball. During impact, the top rail angle **1045** changes and temporarily stores some of the energy of the impact as well as temporarily transferring some of the energy to the rear wall **1023** and the external cavity **1030**. The deflection-induced hinge motion at the top rail hinge point **1070** can cause the rear wall **1023** to move relative to the top rail **1015**. Furthermore, the motion of the rear wall **1023** causes the rear angle **1040** to change during

impact. Similar to the top rail angle **1045**, the rear angle **1040** can temporarily store energy during impact. Much of the stored energy around the top rail hinge point **1070** and the structure surrounding the rear angle **1040** is transferred back to the golf ball when the top rail angle **1045** and the rear angle **1040** restore to their original positions. The energy imparted to the golf ball can increase ball speed and travel distance of the golf ball.

Additionally, cavity **1030** provides a greater dispersion of stress along top rail hinge point **1070** region of the top rail **1015** and the spring back force is transferred from cavity **1030** and top rail **1015** to strikeface **1012**. A standard top rail without a cavity does not have this hinge/buckling effect, nor does it absorb a high level of stress over a large volumetric area of the top rail. Therefore, the standard strikeface does not contract and then recoil as much as strikeface **1012**.

The top wall **1017** and the rear wall **1019** of the external cavity **1030** hinge about the first inflection point **1082**. This hinge-like mobility at the first inflection point **1082** allows greater strikeface **1012** deflection during impact. During impact, the back cavity angle **1035** changes and temporarily stores some of the energy of the impact. This stored energy is transferred back to the golf ball when the top wall **1017** and rear wall **1019** return to their original positions, such that the original back cavity angle **1035** is restored. In this way, the back cavity **1030** stores energy, releases energy, and relieves stresses on the top rail **1015**.

Further, both a larger region of strikeface **1012** and top rail **1015** absorb more stress than the same crown region of a standard golf club head with a standard top rail and no cavity. The top rail thickness **1052** of golf club head **1000** enables the deflection of the strikeface **1012** and the hinge of upper portion of the crown **1008** on impact with a golf ball. Further, the thin top rail **1015** and cavity **1030** comprising inflection point **1082** allow bending across the top rail **1015**, rear wall **1023**, and top wall **1017** of cavity **1030** during impact to transfer energy to the cavity **1030**. The cavity **1030** is able to store to impact energy due to the thin top rail **1015** and inflection point **1082** of the cavity **1030**, and transfer the stored energy back to the ball on impact. The combination of the top rail thickness **1052** and the structure of the back cavity **1030** provide maximum energy storage and stress dispersion that results in improved ball speed without sacrificing durability. Furthermore, because the top rail **1015** has a thickness less than a strikeface thickness, the impact caused by collision of the club head with a golf ball will cause deflection of both the strikeface **1012** and the top rail **1015**. Conversely, a club head having a thick top rail comprises a rigid structure that blocks the deflection energy from being stored and transferred through the crown to other portions of the body and back to the golf ball.

In many embodiments, although there is greater stress along a greater area above cavity **1030** than the same area in a standard club without the cavity, the durability of the club head with and without the cavity is the same. By adding more spring to the back end of the club (due to the inward inclination of top wall **1017** toward strikeface **1012**), more force is displaced throughout the volume of the structure. The stress is observed over a greater area of strikeface **1012** and top rail **1015** of golf club head **1000**. Peak stresses can be seen in the standard top rail club head. However, more peak stresses are seen in golf club head **1000**, but distributed over a large volume of the material. The hinge and bend regions of golf club head **1000** (i.e., the region above cavity **1030** and cavity **1030** itself) will not deform as long as the stress does not meet the critical buckling threshold. Cavity

1030 and its placement can be design to be under the critical K value of the buckling threshold.

III. Golf Club Head with Cascading Sole and Back Cavity

In some embodiments, a golf club head with a back cavity can further comprise a cascading sole with tiered thin sections. FIG. **14** illustrates a cross-section of golf club head **1100**, which can be similar to golf club head **1000** (FIG. **10**), along a similar cross-sectional line XII-XII in FIG. **10**, according to an embodiment. Similar to golf club head **1000** (FIG. **10**), golf club head **1100** comprises a body **1101**. Body **1101** comprises a strikeface **1112**, a sole **1106**, and a crown **1108**. Strikeface **1112** comprises a high region **1176**, a middle region **1174**, and a low region **1172**. Crown **1108** comprises an upper region **1111** and a lower region **1113**. Upper region **1111** comprises a top rail **1115**. In many embodiments, a cavity **1130** is located below top rail **1115**. Golf club head **1100** further comprises a cascading sole **1310**, similar to internal radius transition **310** (FIG. **3**). Internal radius transition **1310** comprises a first tier **1315** at a first thickness, a second tier **1317** at a second thickness, and a tier transition region **1316**. In some embodiments, cascading sole **1310** can provide further pliability to top rail **1115**. In many embodiments, the back cavity combined with the cascading sole can provide an even greater spring effect on the strikeface. In some embodiments, the back cavity with the cascading sole allows approximately 3%-5% more energy in the deflection of the strikeface. The cascading sole **1310** can include any number of tiers greater than or equal to two tiers. For example, the cascading sole **1310** can have 2, 3, 4, 5, 6, or 7 tiers.

The golf club head **1100** having the cascading sole and the back cavity can provide a greater recoiling force to the strikeface than the golf club head having the cascading sole or back cavity alone. This is due to the combined increased recoiling force from both the internal radius transition and the back cavity, as discussed above. The increased recoiling force to the strikeface leads to greater deflection, which in turn increases the impact force applied to the golf ball thereby increasing the speed of the golf ball. In some embodiments, golf club head **1100** comprising both cavity **1130** and internal radius transition **1310** can increase ball speed, increase launch angle, and provide better distance control. In various embodiments, golf club head **1100** can increase ball speeds approximately 1% to approximately 4%. In some embodiments, golf club head **1100** can increase ball speeds approximately 1%, 2%, 3%, or 4%. In many embodiments, golf club head **1100** provides a larger increase in ball speeds when the golf ball impacts the strikeface in high region **1176**. In some embodiments, golf club head **1100** can increase the launch angle by approximately 0.5 degrees to approximately 1.1 degrees. In some embodiments, golf club head **1100** can increase the launch angle by approximately 0.5 degrees, 0.6 degrees, 0.7 degrees, 0.8 degrees, 0.9 degrees, 1.0 degrees, or 1.1 degrees.

An embodiment of golf club head **1100** having the cascading sole and the back cavity was tested. Overall, when compared to a control golf club head devoid of the cascading sole and the back cavity, the cavity golf club head showed an increase in golf ball speed and an increase in launch angle. The cavity golf club head showed the increase in golf ball speed and the increase in launch angle for all contact positions on the face due to the combined spring effect from the combination of cascading sole **1310** (FIG. **14**) and cavity **1130** (FIG. **14**). In some embodiments, a greater increase in golf ball speed and launch angle was observed on contact with high portions of the face, (e.g., high region **1076** (FIG. **12**) or high region **1176** (FIG. **14**)) due in part from the

spring effect of cavity **1130** (FIG. **14**). FIGS. **19-20** depicts results from the testing of the embodiment of golf club head **1100** (cavity golf club head) compared to a standard iron-type golf club head (control golf club head) with a closed back design and similar loft angle as the cavity golf club head. FIG. **19** shows an increase in golf ball speed in the cavity golf club head compared to the control golf club head when the golf ball impacts the high region of the strikeface, and FIG. **20** shows an increase in launch angle of the cavity golf club head compared to the control golf club head when the golf ball impacts the high region of the strikeface.

Specifically, FIG. **19** shows that golf ball speed is increased by approximately 1.9% (or approximately 2.5 mph) for the cavity golf club head when the golf ball impacts a high-toe region of the strikeface, approximately 2.1% (or approximately 2.8 mph, or approximately 4.5 kph) when the golf ball impacts a high-center region of the strikeface, and approximately 1.5% (or approximately 2.0 mph, or approximately 3.2 kph) when the golf ball impacts a high-heel region of the strikeface (all of the cavity golf club head), when compared to the control golf club head. When the golf ball impacts the strikeface in the high-toe region of the control golf club head, the golf ball speed is approximately 132.5 mph (213.2 kph), while the golf ball reaches approximately 135.0 mph (217.3 kph) when it impacts the strikeface in the high-toe region of the cavity golf club head. When the golf ball impacts the strikeface in the high-center region of the control golf club head, the golf ball speed is approximately 133.4 mph (214.7 kph), while the golf ball reaches approximately 136.2 mph (219.2 kph) when it impacts the strikeface in the high-center region of the cavity golf club head. When the golf ball impacts the strikeface in the high-heel region of the control golf club head, the golf ball speed is approximately 134.0 mph (215.7 kph), while the golf ball reaches approximately 136.0 mph (218.9 kph) when it impacts the strikeface in the high-heel region of the cavity golf club head.

FIG. **20** shows that launch angle of the cavity golf club head is increased by approximately 4.2% (or approximately 0.6 degrees) when the golf ball impacts the high-toe region of the strikeface, approximately 4.8% (or approximately 0.7 degrees) when the golf ball impacts the high-center region of the strikeface, and approximately 6.4% (or approximately 0.9 degrees) when the golf ball impacts the high-heel region of the strikeface (all of the cavity golf club head), when compared with the control golf club head. When the golf ball impacts the strikeface in the high-toe region of the control golf club head, the launch angle is approximately 14.4 degrees, while the launch angle is approximately 15.0 degrees when it impacts the strikeface in the high-toe region of the cavity golf club head. When the golf ball impacts the strikeface in the high-center region of the control golf club head, the launch angle is approximately 14.5 degrees, while the launch angle is approximately 15.2 degrees when it impacts the strikeface in the high-center region of the cavity golf club head. When the golf ball impacts the strikeface in the high-heel region of the control golf club head, the launch angle is approximately 14.1 degrees, while the launch angle is approximately 15.0 degrees when it impacts the strikeface in the high-heel region of the cavity golf club head.

FIG. **17** illustrates method **1700** for manufacturing a golf club head. Method **1700** comprises providing a body (block **1705**). Providing a body in block **1705** comprises the body having a strikeface, a heel region, a toe region opposite the heel region, a sole, and a crown. In many embodiments, the crown comprises an upper region and a lower region. In some embodiments, the upper region comprises a top rail. In

many embodiments, a cavity is located below the top rail and is located above the lower region of the crown (block **1710**). In some embodiments, the cavity is defined at least in part by the upper and lower regions of the crown. The cavity comprises a top wall, a back wall adjacent to the top wall, a bottom incline adjacent to the back wall, a back cavity angle measured between the top and back walls of the cavity, and at least one channel.

In some embodiments, method **1700** further comprises providing an insert at the lower region of the crown towards the toe region. In some embodiments, the insert is similar to insert **1062** (FIG. **10**).

In some embodiments, providing the body in block **1705** further comprises the body having a cascading sole. The cascading sole comprises an internal radius transition region from the strikeface to the sole. In many embodiments, the internal radius transition region can be similar to internal transition region or cascading sole **1310** (FIG. **14**). In some embodiments, the internal transition region comprises a first tier comprising a first thickness, a second tier comprising a second thickness smaller than the first thickness, and a tier transition region between the first tier and the second tier. IV. Golf Club with Cascading Sole and Back Cavity

Turning to FIG. **15**, FIG. **15** illustrates a golf club **1500** comprising a golf club head **1500** and a shaft **1590** coupled to golf club head **1500**. In some embodiments, golf club head **1500** of golf club **15000** comprises a hybrid-type golf club head. In other embodiments, golf club head **1500** can be an iron-type golf club head or a fairway wood-type golf club head. In many embodiments, golf club head **1500** can be similar to golf club head **100** or golf club head **1000** (FIG. **10**). Golf club head **1500** can be hollow-bodied and comprises a strikeface **1512**, a heel region **1502**, a toe region **1504** opposite heel region **1502**, a sole **1506**, and a crown **1508**. Crown **1508** comprises an upper region **1511** and a lower region **1513**. Upper region **1511** comprises a top rail **1515**. Golf club head **1500** further comprises a cavity **1530** located below top rail **1515** and above lower region **1513** of crown **1508**.

FIG. **16** illustrates a cross-section of golf club head **1500** along the cross-sectional line XVI-XVI in FIG. **15**, according to one embodiment. In some embodiments, cavity **1530** can be defined at least in part by upper region **1511** and lower region **1513**. In many embodiments, cavity **1530** comprises a top wall **1517**, a back wall **1519**, a bottom incline **1521**, a back cavity angle **1535** measured between top wall **1517** and back wall **1519**, and at least one channel **1539**. In some embodiments, an apex of top wall **1517** is approximately 0.25 inch to approximately 1.25 inches below an apex of top rail **1515**. In some embodiments, the apex of top wall **1517** is approximately 0.375 inch below the apex of top rail **1515**. In some embodiments, bottom incline **1521** can be at least approximately 0.50 inch to approximately 2 inches below an apex of top rail **1515**. In many embodiments, back cavity angle **1535** can be approximately 70 degrees to approximately 110 degrees. In some embodiments, back cavity angle **1535** can be approximately 90 degrees.

In many embodiments, upper region **1511** comprises the top and back walls of the cavity; and the lower region of the crown comprises the bottom incline of the cavity. In some embodiments, upper region **1511** further comprises a rear wall **1523** adjacent to top wall **1517** of cavity **1530** and a rear angle **1540** measured between top wall **1517** of cavity **1530** and rear wall **1523** of upper region **1511**. In many embodiments, rear angle **1540** is approximately 70 degrees to approximately 110 degrees.

25

In another embodiment, the golf club head can comprise a hosel. The hosel can comprise a hosel notch. The hosel notch can allow for iron-like range of loft and lie angle adjustability. Although not illustrated in FIG. 16, golf club head 1500 also can have a cascading sole or an internal radius transition at the sole.

The golf club heads with energy storage characteristics discussed herein may be implemented in a variety of embodiments, and the foregoing discussion of these embodiments does not necessarily represent a complete description of all possible embodiments. Rather, the detailed description of the drawings, and the drawings themselves, disclose at least one preferred embodiment of golf club heads with energy storage characteristics, and may disclose alternative embodiments of golf club heads with tiered internal thin sections.

Replacement of one or more claimed elements constitutes reconstruction and not repair. Additionally, benefits, other advantages, and solutions to problems have been described with regard to specific embodiments. The benefits, advantages, solutions to problems, and any element or elements that may cause any benefit, advantage, or solution to occur or become more pronounced, however, are not to be construed as critical, required, or essential features or elements of any or all of the claims, unless such benefits, advantages, solutions, or elements are expressly stated in such claims.

As the rules to golf may change from time to time (e.g., new regulations may be adopted or old rules may be eliminated or modified by golf standard organizations and/or governing bodies such as the United States Golf Association (USGA), the Royal and Ancient Golf Club of St. Andrews (R&A), etc.), golf equipment related to the apparatus, methods, and articles of manufacture described herein may be conforming or non-conforming to the rules of golf at any particular time. Accordingly, golf equipment related to the apparatus, methods, and articles of manufacture described herein may be advertised, offered for sale, and/or sold as conforming or non-conforming golf equipment. The apparatus, methods, and articles of manufacture described herein are not limited in this regard.

While the above examples may be described in connection with a driver-type golf club, the apparatus, methods, and articles of manufacture described herein may be applicable to other types of golf club such as a fairway wood-type golf club, a hybrid-type golf club, an iron-type golf club, a wedge-type golf club, or a putter-type golf club. Alternatively, the apparatus, methods, and articles of manufacture described herein may be applicable to other type of sports equipment such as a hockey stick, a tennis racket, a fishing pole, a ski pole, etc.

Moreover, embodiments and limitations disclosed herein are not dedicated to the public under the doctrine of dedication if the embodiments and/or limitations: (1) are not expressly claimed in the claims; and (2) are or are potentially equivalents of express elements and/or limitations in the claims under the doctrine of equivalents.

What is claimed is:

1. A golf club head comprising:
 - a hollow body defining an enclosed internal void, the body comprising:
 - a strikeface;
 - a heel region;
 - a toe region opposite the heel region;
 - a sole;
 - a top rail; and

26

- a rear portion extending between the top rail and the sole and on an opposite side of the internal void from the strikeface, the rear portion comprising:
 - a top cavity wall;
 - a back cavity wall adjacent to the top cavity wall;
 - an inflection point defining a junction between the top cavity wall and the back cavity wall; and
 - a back cavity angle measured at the inflection point between the top cavity wall and the back cavity wall;
 wherein the top cavity wall is angled toward the strikeface and away from the top rail in a direction toward the inflection point;
 - wherein the strikeface, the sole, the top rail, the rear portion, the heel region, and the toe region cooperate to define the enclosed internal void; and
 - wherein the top rail comprises a thickness less than a thickness of the strikeface; and
 - wherein the back cavity angle is approximately 70 degrees to approximately 110 degrees.
- 2. A golf club head comprising:
 - a hollow body defining an enclosed internal void, the body comprising:
 - a strikeface;
 - a heel region;
 - a toe region opposite the heel region;
 - a sole;
 - a top rail; and
 - a rear portion extending between the top rail and the sole and on an opposite side of the internal void from the strikeface, the rear portion comprising:
 - a top cavity wall;
 - a back cavity wall adjacent to the top cavity wall;
 - an inflection point defining a junction between the top cavity wall and the back cavity wall; and
 - a back cavity angle measured at the inflection point between the top cavity wall and the back cavity wall;
 wherein the top cavity wall is angled toward the strikeface and away from the top rail in a direction toward the inflection point;
 - wherein the strikeface, the sole, the top rail, the rear portion, the heel region, and the toe region cooperate to define the enclosed internal void; and
 - wherein the top rail comprises a thickness less than a thickness of the strikeface; and
 the rear portion further comprising:
 - a rear wall extending between the top wall of the cavity and the top rail; and
 - a rear angle measured between the top wall of the cavity and the rear wall; and
 - wherein the rear angle is approximately 70 degrees to approximately 110 degrees.
- 3. The golf club head of claim 1, wherein:
 - the back cavity wall is substantially parallel to the strikeface.
- 4. A golf club head comprising:
 - a hollow body defining an enclosed internal void, the body comprising:
 - a strikeface;
 - a heel region;
 - a toe region opposite the heel region;
 - a sole;
 - a top rail; and
 - a rear portion extending between the top rail and the sole and on an opposite side of the internal void from the strikeface, the rear portion comprising:

a top cavity wall;
 a back cavity wall adjacent to the top cavity wall;
 an inflection point defining a junction between the top cavity wall and the back cavity wall; and
 a back cavity angle measured at the inflection point between the top cavity wall and the back cavity wall;
 wherein the top cavity wall is angled toward the strikeface and away from the top rail in a direction toward the inflection point;
 wherein the strikeface, the sole, the top rail, the rear portion, the heel region, and the toe region cooperate to define the enclosed internal void; and
 wherein the top rail comprises a thickness less than a thickness of the strikeface; and
 wherein an apex of the top cavity wall is approximately 0.25 inch to approximately 1.25 inch below an apex of the top rail.

5. The golf club head of claim 1, further comprising:
 a cascading sole;
 wherein the cascading sole comprises an internal radius transition region from the strikeface to the sole;
 and the internal transition region comprises:
 a first tier comprising a first thickness;
 a second tier comprising a second thickness different than the first thickness; and
 a tier transition region between the first tier and the second tier.

6. The golf club head of claim 5, wherein the internal transition region further comprises a third tier.

7. The golf club head of claim 1, wherein the club head has a total volume that is greater than 40 cubic centimeters.

8. The golf club head of claim 7, wherein a total volume of the enclosed internal void is greater than 10 cubic centimeters.

9. The golf club head of claim 1, wherein the enclosed internal void is positioned behind 60% or more of the strikeface.

10. The golf club head of claim 1, wherein the enclosed internal void is positioned behind 90% or more of the strikeface.

11. The golf club head of claim 1, wherein the thickness of the top rail is less than 0.070 inch.

12. The golf club head of claim 1, wherein the thickness of the strikeface is between 0.060 and 0.150 inch.

13. The golf club head of claim 1, wherein an apex of the top cavity wall is approximately 0.25 inch to approximately 1.25 inch below an apex of the top rail.

14. The golf club head of claim 2, wherein the back cavity angle is approximately 70 degrees to approximately 110 degrees.

15. The golf club head of claim 2, wherein an apex of the top cavity wall is approximately 0.25 inch to approximately 1.25 inch below an apex of the top rail.

16. The golf club head of claim 2, further comprising:
 a cascading sole;
 wherein the cascading sole comprises an internal radius transition region from the strikeface to the sole;
 and the internal transition region comprises:
 a first tier comprising a first thickness;
 a second tier comprising a second thickness different than the first thickness; and
 a tier transition region between the first tier and the second tier.

17. The golf club head of claim 2, wherein the club head has a total volume that is greater than 40 cubic centimeters.

18. The golf club head of claim 2, wherein the thickness of the top rail is less than 0.070 inch.

19. The golf club head of claim 4, further comprising:
 a cascading sole;
 wherein the cascading sole comprises an internal radius transition region from the strikeface to the sole;
 and the internal transition region comprises:
 a first tier comprising a first thickness;
 a second tier comprising a second thickness different than the first thickness; and
 a tier transition region between the first tier and the second tier.

20. The golf club head of claim 4, wherein the thickness of the top rail is less than 0.070 inch.

* * * * *