



US 20120172784A1

(19) **United States**  
(12) **Patent Application Publication**  
**Soden**

(10) **Pub. No.: US 2012/0172784 A1**  
(43) **Pub. Date: Jul. 5, 2012**

(54) **DEVICE FOR TREATING TISSUE**

**Publication Classification**

(76) Inventor: **Declan Soden, County Cork (IE)**

(51) **Int. Cl.**  
*A61M 37/00* (2006.01)  
*A61N 1/04* (2006.01)

(21) Appl. No.: **13/395,242**

(52) **U.S. Cl.** ..... **604/20; 607/148**

(22) PCT Filed: **Sep. 10, 2010**

(57) **ABSTRACT**

(86) PCT No.: **PCT/IE10/00053**

§ 371 (c)(1),  
(2), (4) Date: **Mar. 9, 2012**

An apparatus for use in carrying out a prophylactic or treatment procedure on tissue comprises a head piece 1 having a receiver 2 for receiving an instrument such as an endoscope 10 and chamber 3 into which tissue is drawn by vacuum. There are two electrodes 11 within the chamber 2 and two electrodes 25 located on opposite sides of the entrance 5 into the chamber. The voltage applied to the inner and outer electrodes 11, 25 can be varied independently and allows tissue underlying the device to be treated. This is particularly important for colorectal cancers.

(30) **Foreign Application Priority Data**

Sep. 10, 2009 (IE) ..... 2009/0688

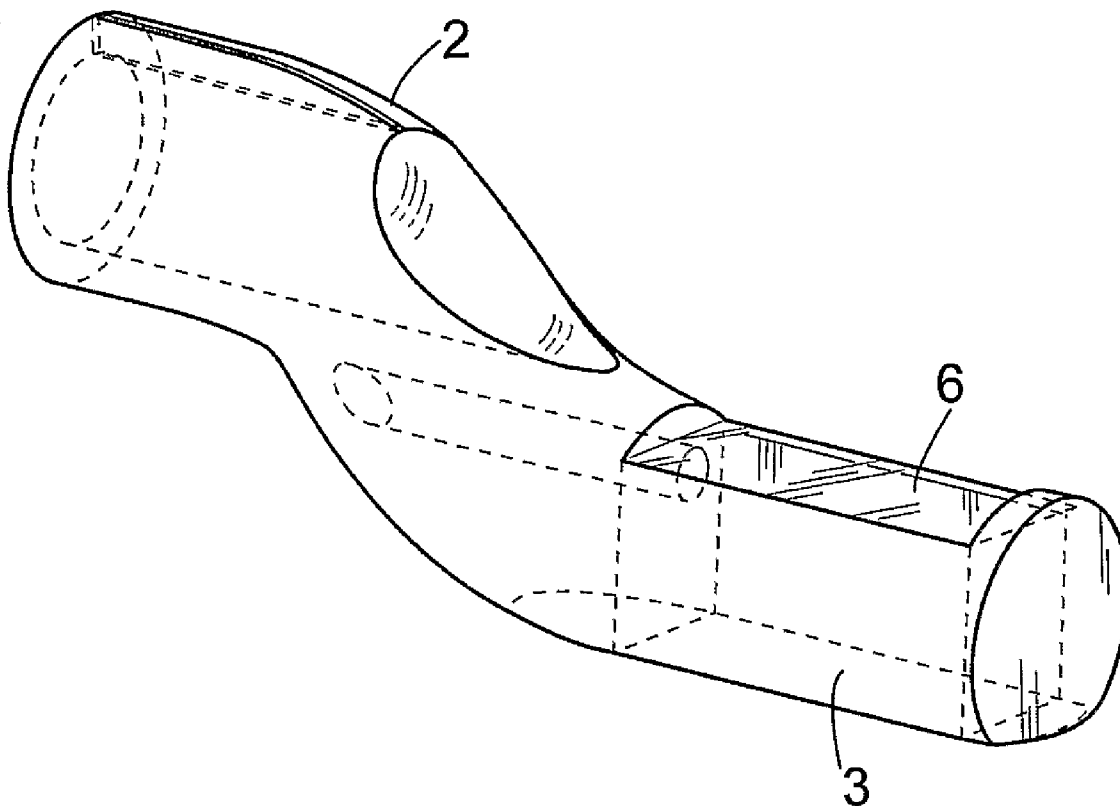

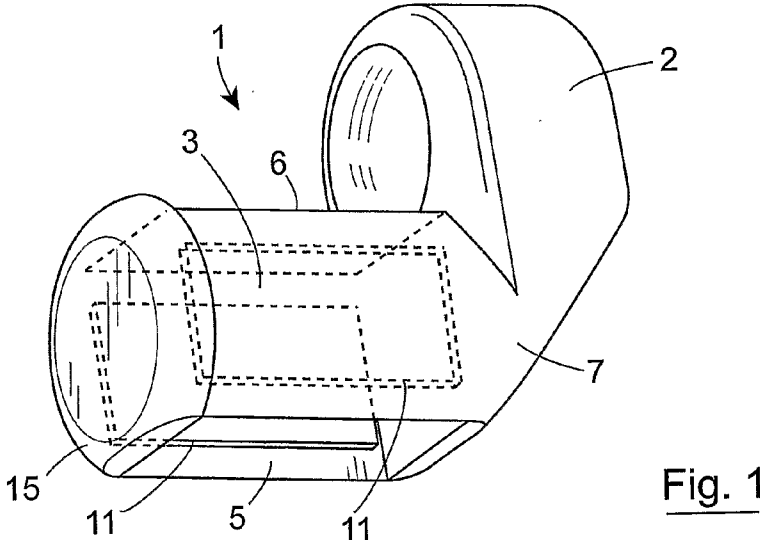

Fig. 1

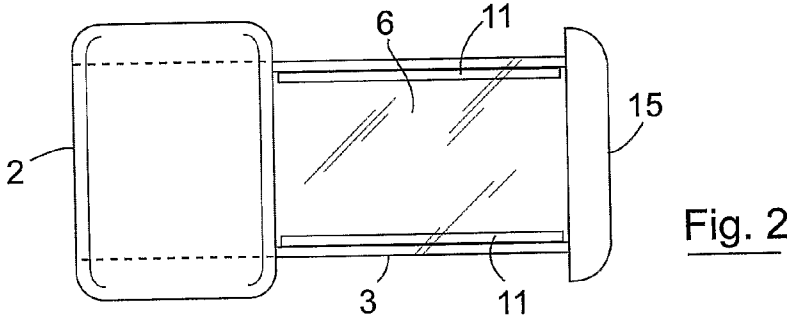

Fig. 2

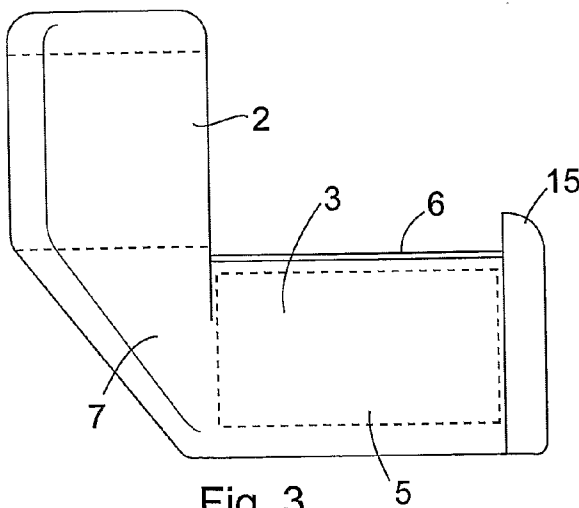

Fig. 3

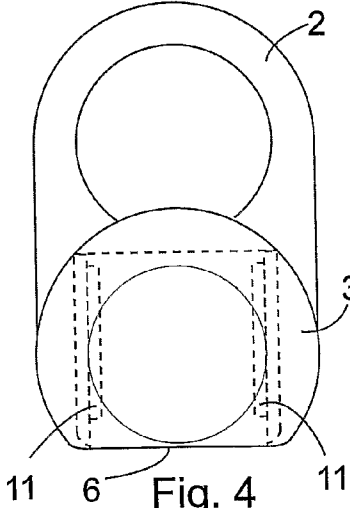

Fig. 4

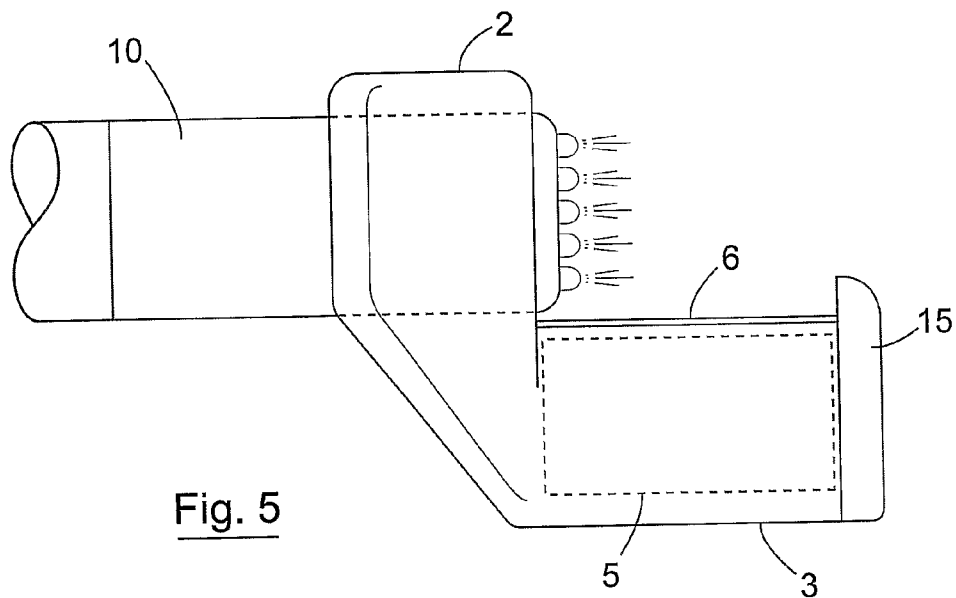

Fig. 5

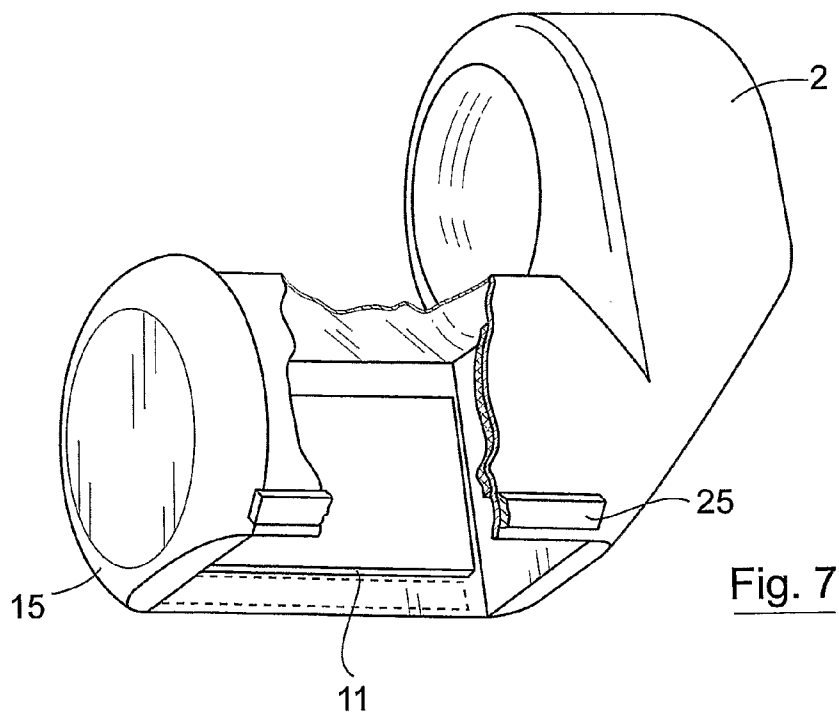
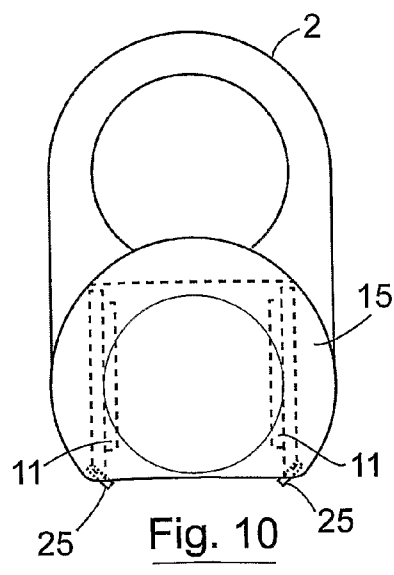
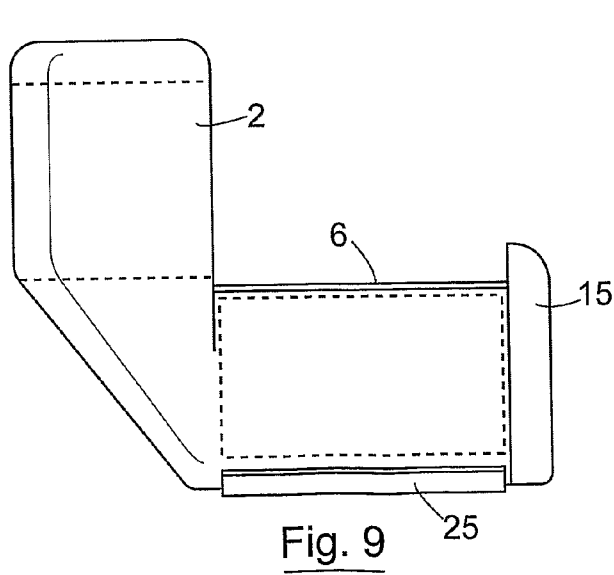
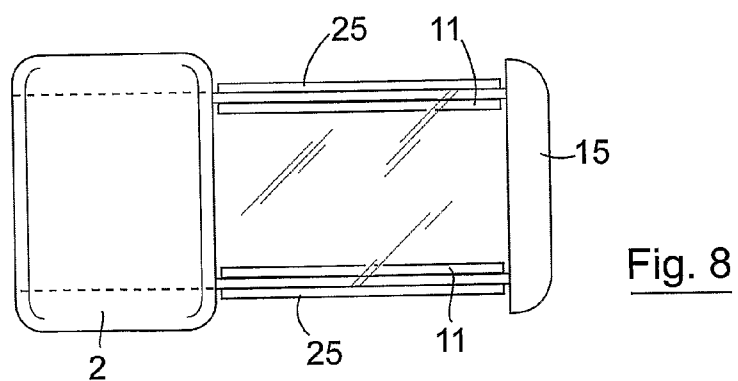
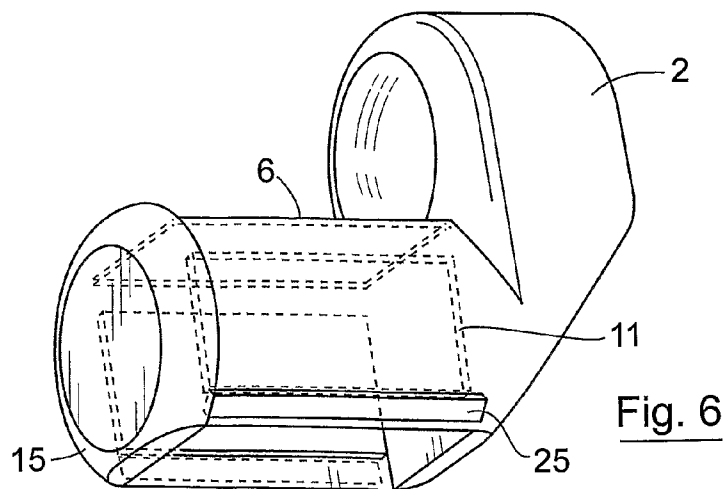

Fig. 7



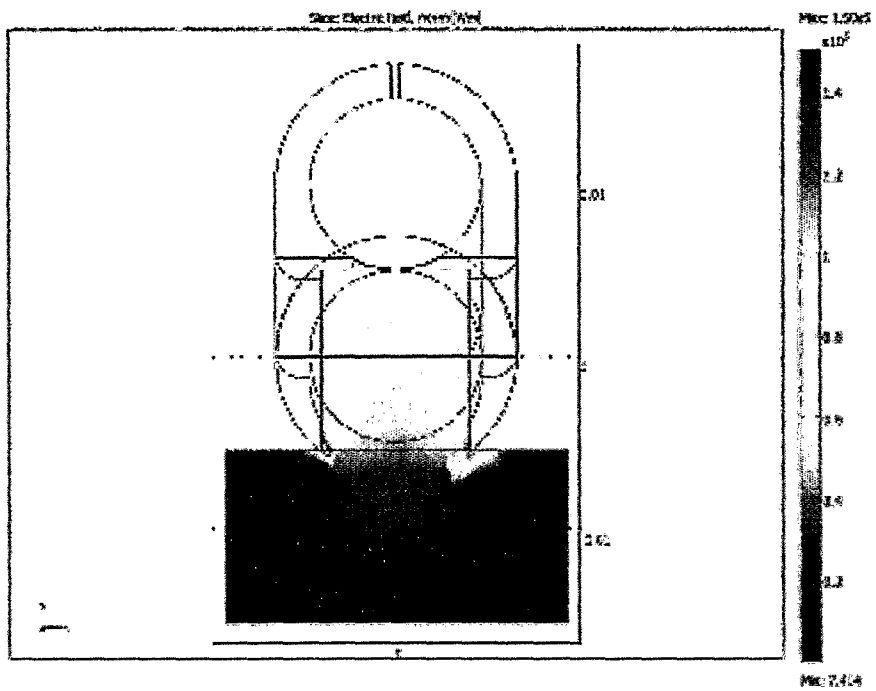

Fig. 11

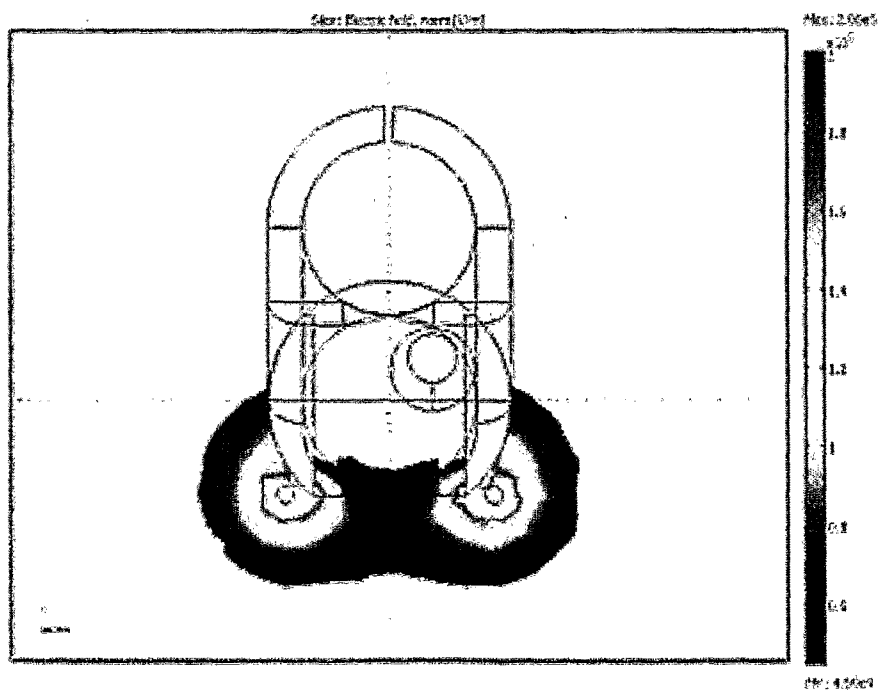

Fig. 12

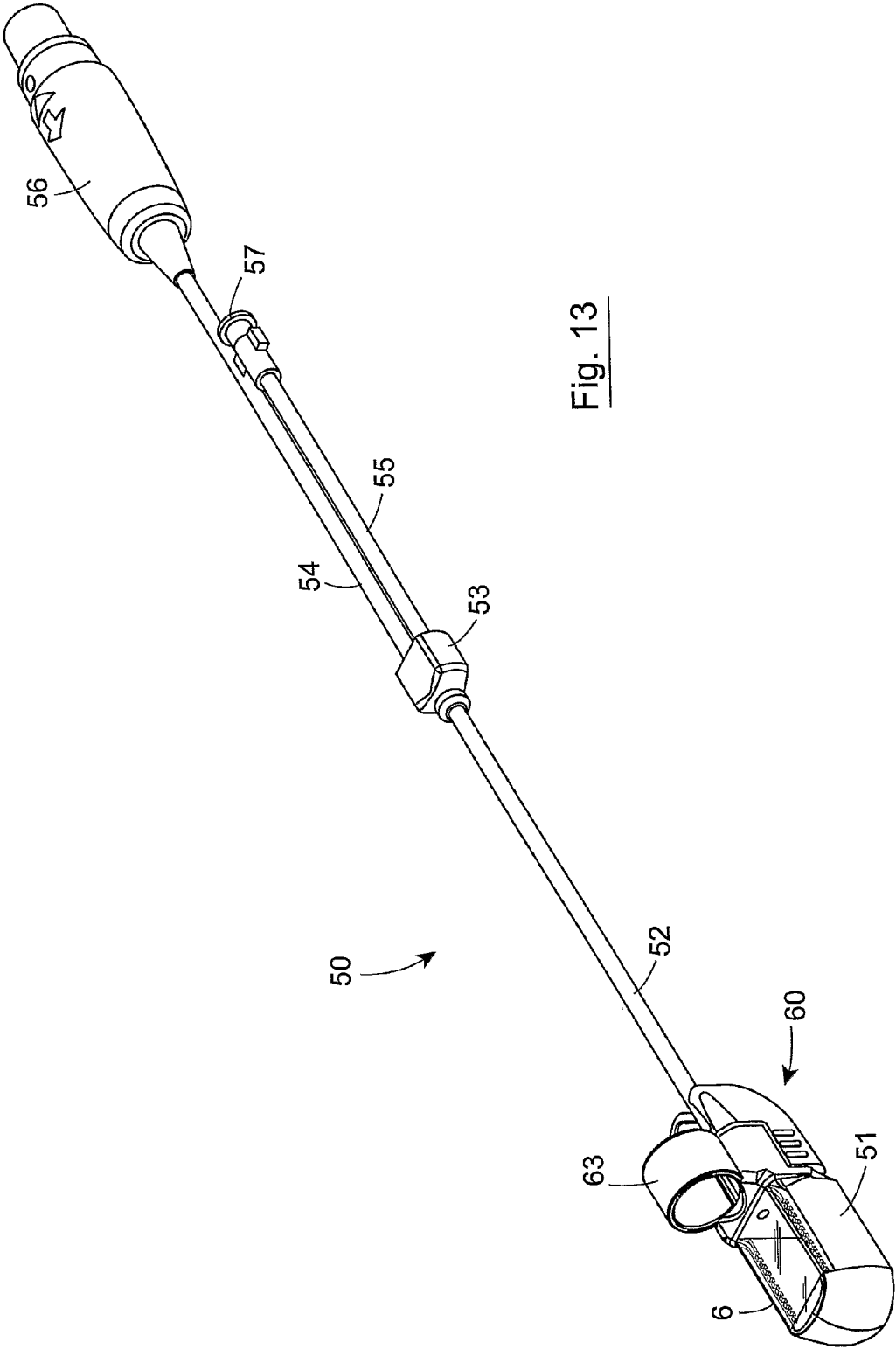

Fig. 13

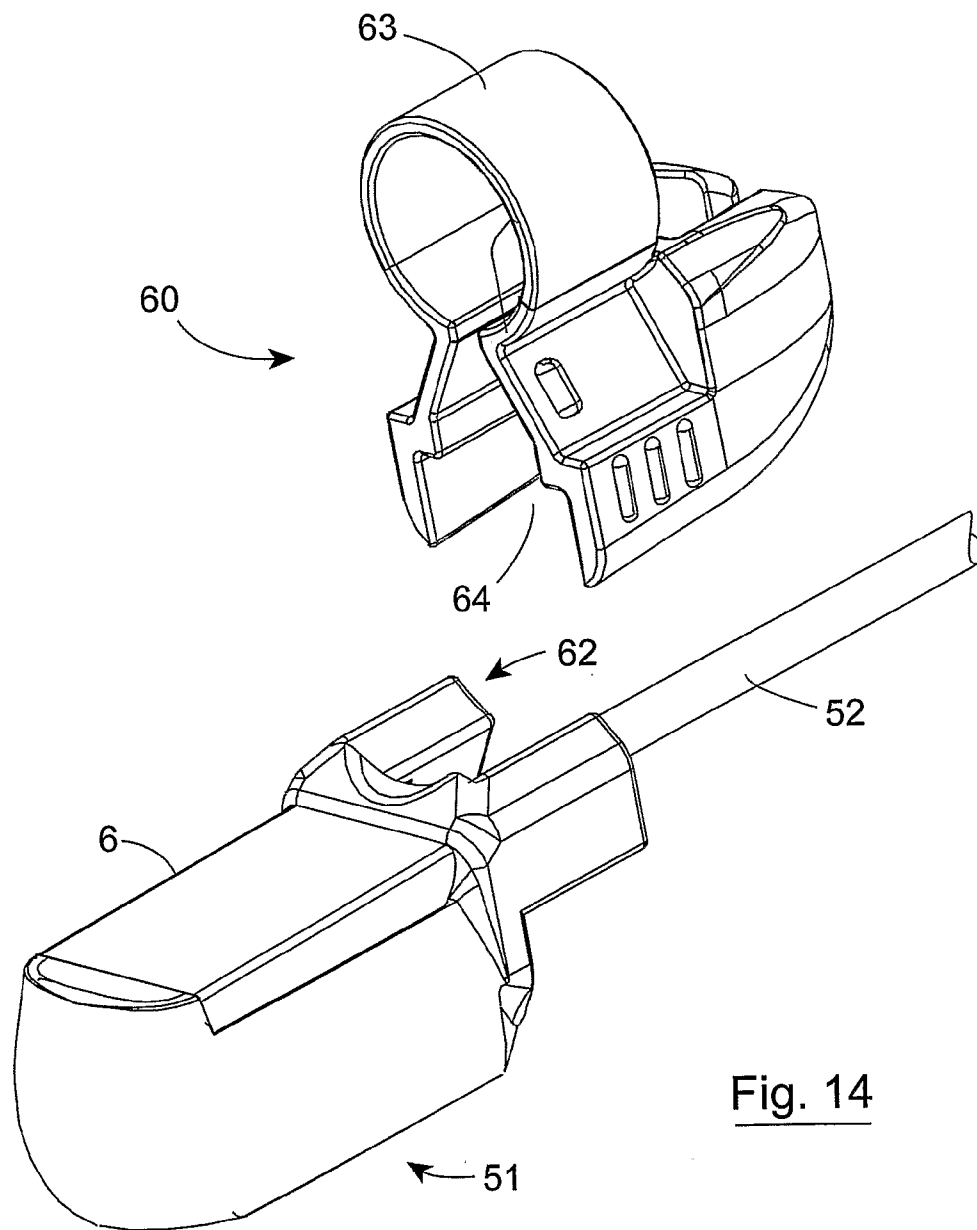

Fig. 14





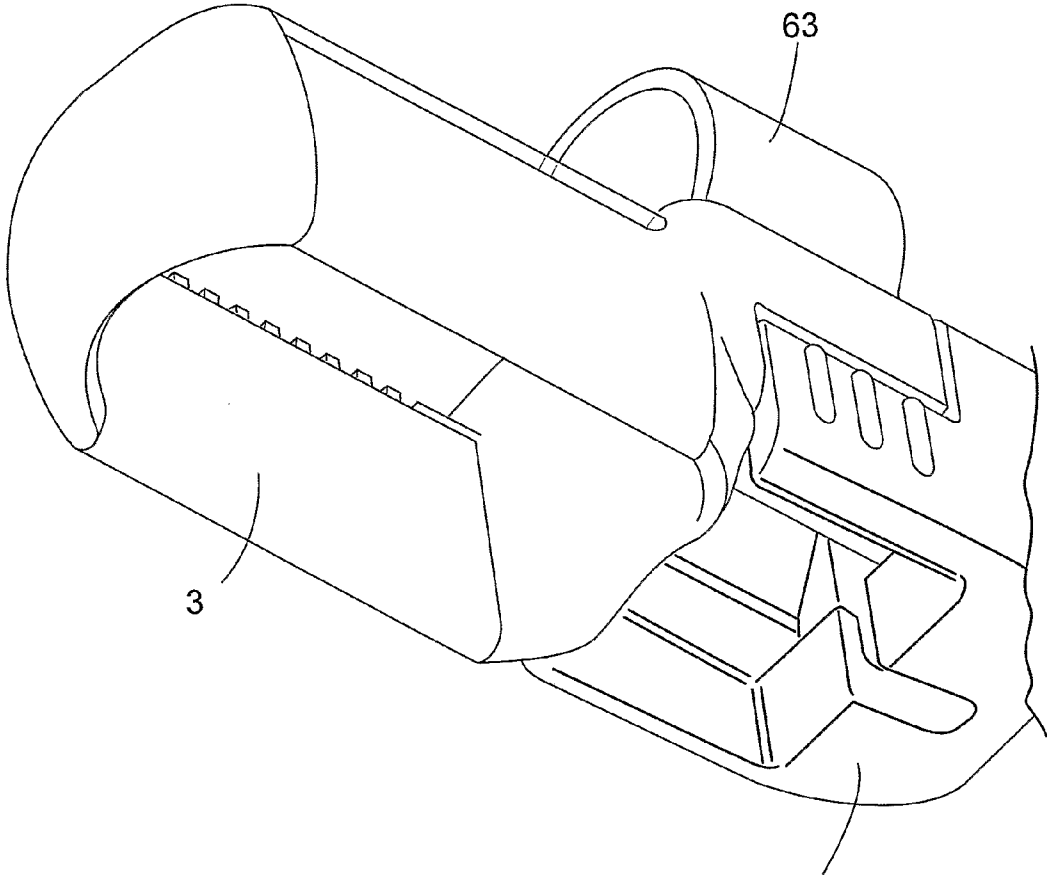
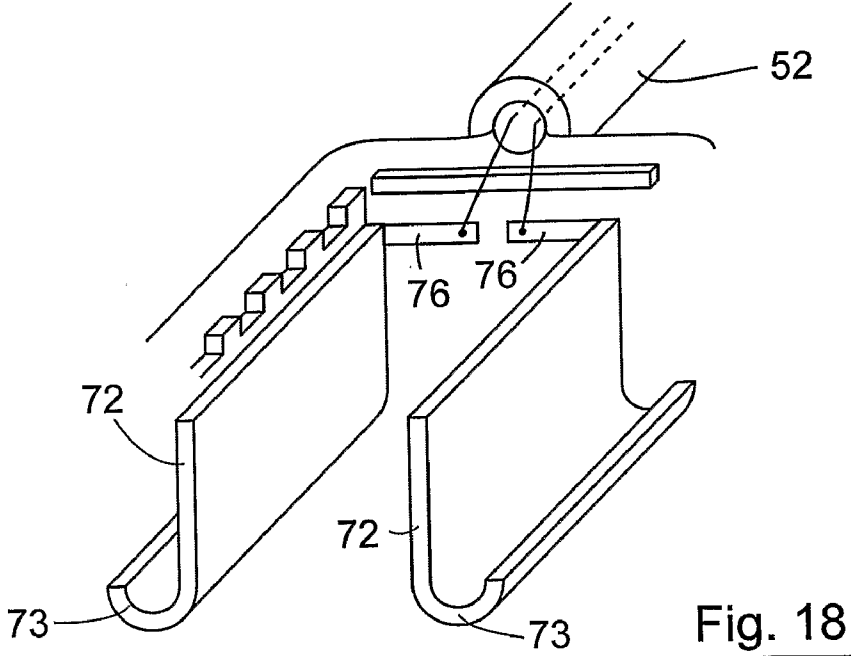
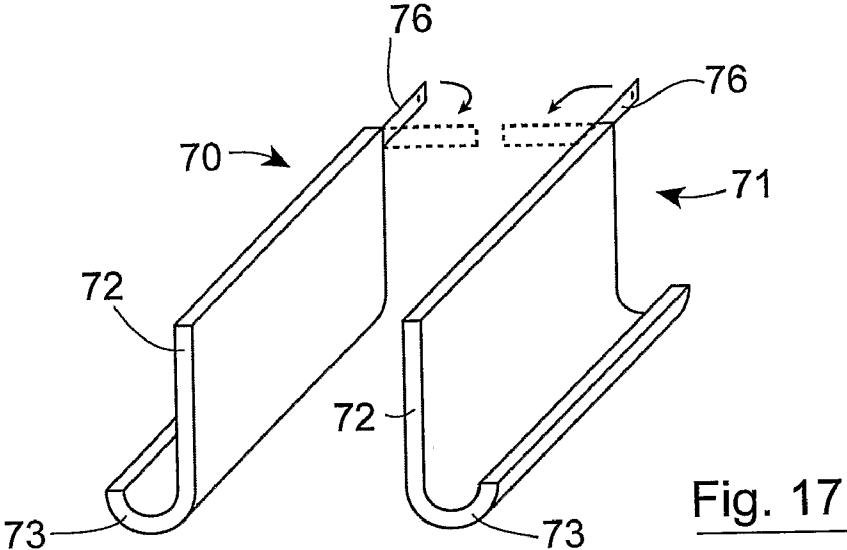

Fig. 16

60



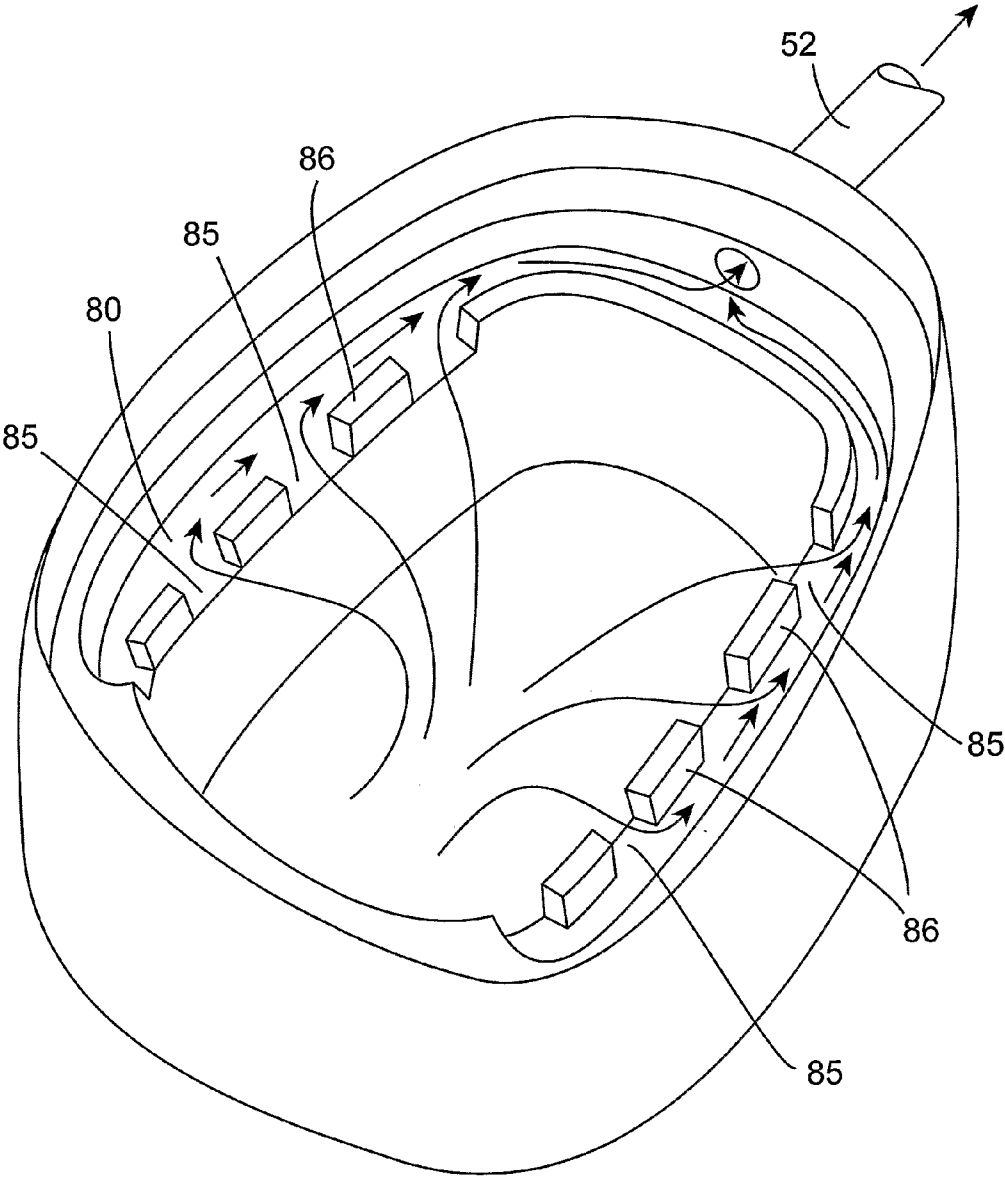

Fig. 19

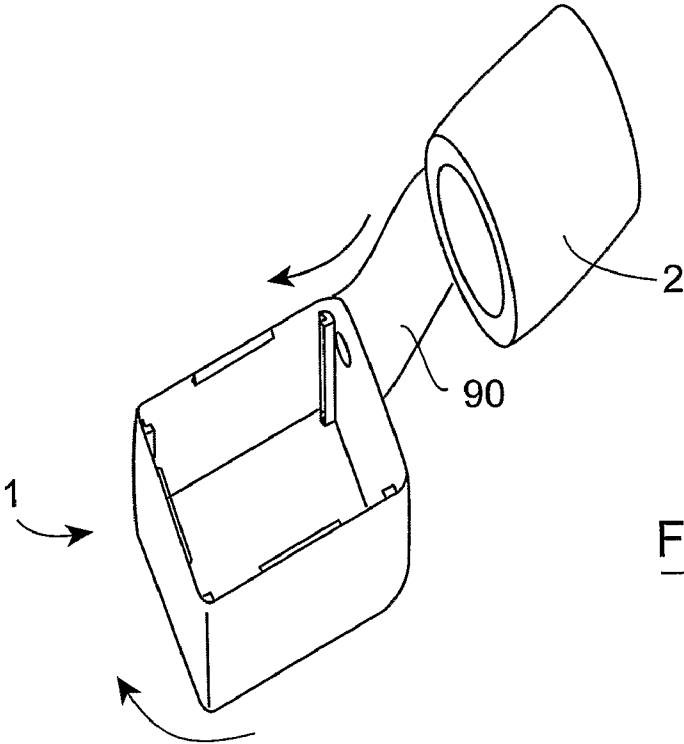

Fig. 20

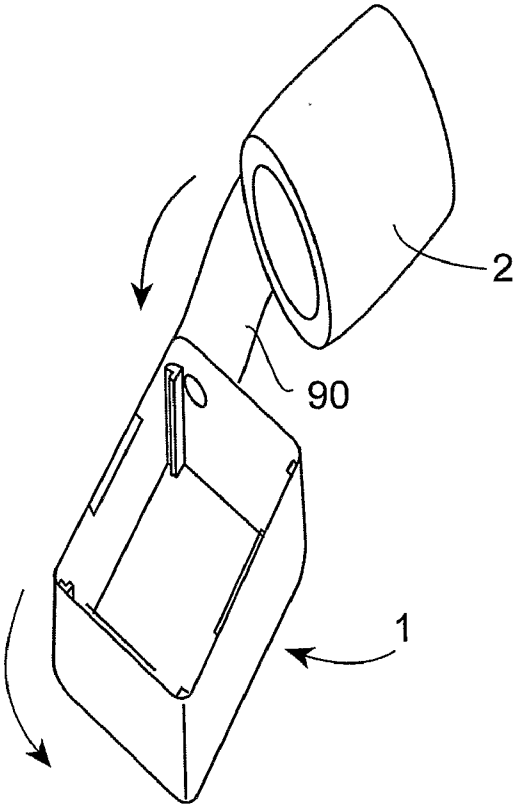

Fig. 21

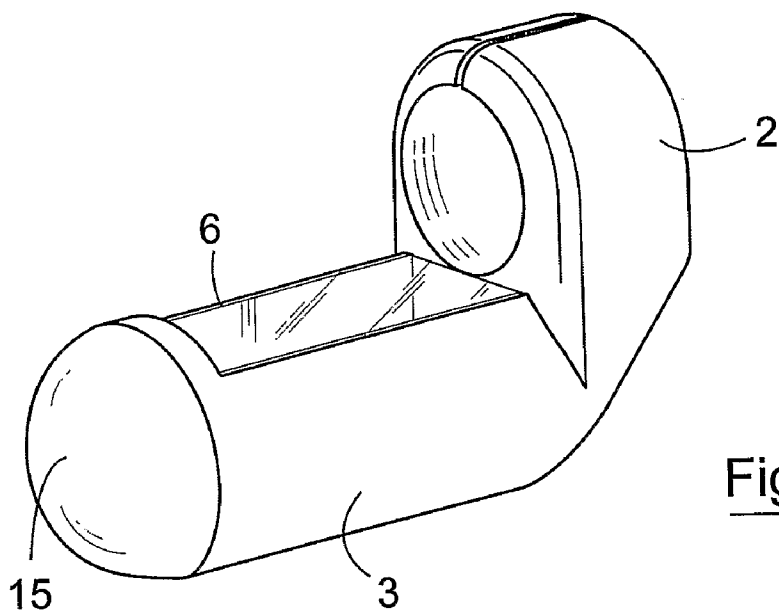

Fig. 22

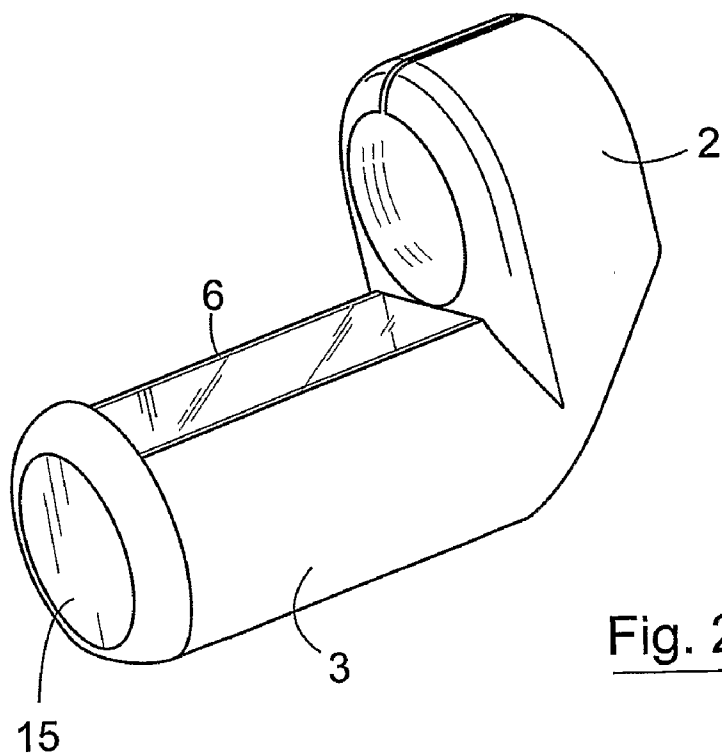

Fig. 23

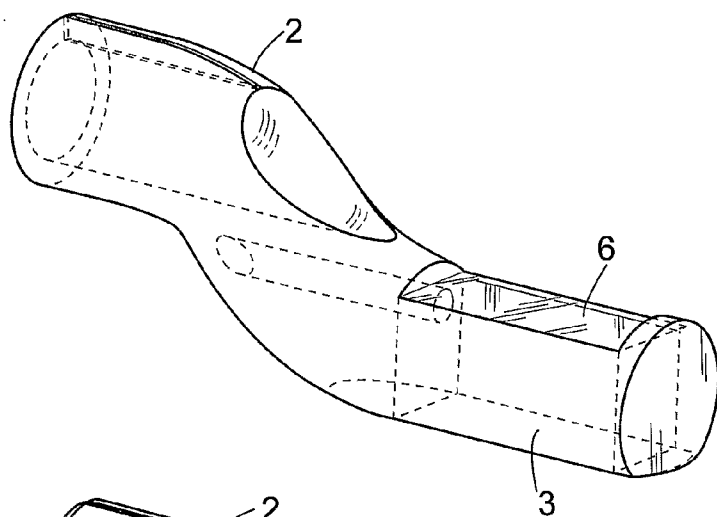

Fig. 24

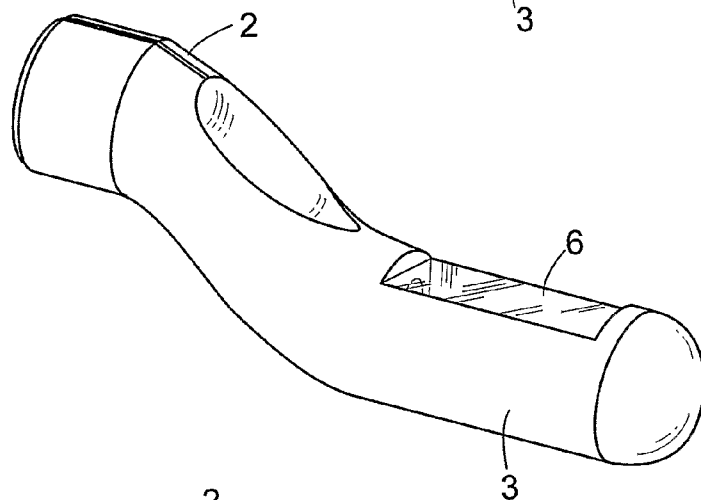

Fig. 25

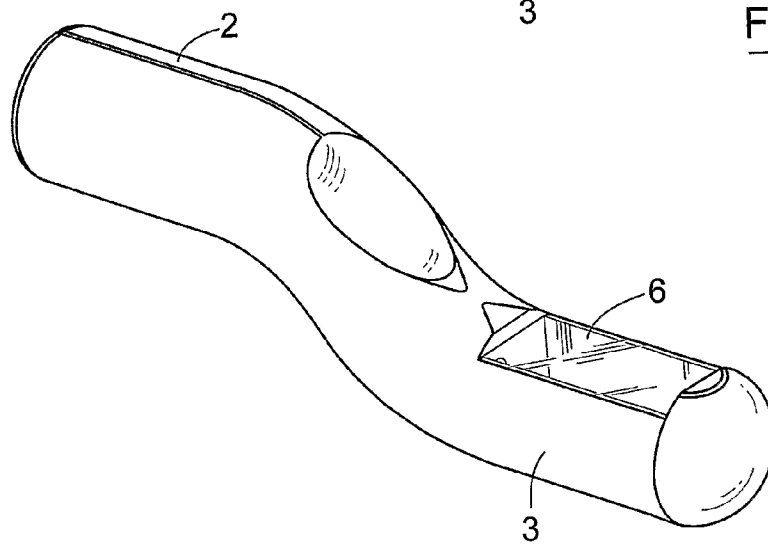

Fig. 26

**DEVICE FOR TREATING TISSUE**

**INTRODUCTION**

[0001] This invention relates to devices and apparatus for use in carrying out prophylactic or treatment procedure on tissue. The invention also relates to a method of prophylaxis or treatment of tissue utilising a device or apparatus of the invention.

[0002] In our WO 2005/092433A we describe an apparatus for carrying out a prophylactic or treatment procedure on tissue comprising a device having a chamber and at least one active element such as an electrode within the chamber. The chamber has an opening through which tissue is drawn into the chamber. Means for drawing the tissue into the chamber may comprise a vacuum lumen with vacuum orifices in the chamber. Treatment such as electroporation may be applied to tissue in the chamber. The entire contents of WO 2005/092433A are herein incorporated by reference.

**STATEMENTS OF INVENTION**

[0003] According to the invention there is provided an apparatus for use in carrying out a prophylactic or treatment procedure on tissue comprising:—

[0004] a head piece having a chamber with an entrance for receiving tissue;

[0005] at least one first active element located within the chamber; and

[0006] at least one second active element located externally of the chamber.

[0007] In one embodiment at least one first active element comprises an electrode.

[0008] In one case at least one second active element comprises an electrode.

[0009] There may be two first electrodes within the chamber. On one case the first electrodes are located on opposed sides of the chamber.

[0010] In one embodiment two second electrodes are provided outside of the chamber. The electrodes may be located on opposite sides of the entrance to the chamber.

[0011] In one embodiment the apparatus comprises means for applying electroporation to tissue located in the chamber.

[0012] In one case the apparatus comprises means for applying electroporation to tissue located outside of the chamber.

[0013] The apparatus in one embodiment comprises means for drawing tissue into the chamber. The means for drawing tissue into the chamber may comprise means for applying a vacuum to tissue. In one case the apparatus comprises a vacuum lumen for connecting the chamber in communication with a vacuum source. There may be one or more vacuum orifices for connecting the vacuum lumen in communication with the chamber.

[0014] In one case the vacuum source is configured to be located externally of a body.

[0015] In one embodiment the longitudinal axis of the vacuum lumen is offset radially from the longitudinal axis of the chamber.

[0016] The means for drawing tissue into the chamber may be configured to draw tissue towards the active element.

[0017] The means for drawing tissue into the chamber may be configured to draw tissue into contact with the active element.

[0018] In one case at least some of the active elements are the same.

[0019] In another case at least some of the active elements are different.

[0020] In one embodiment at least one active element has a therapeutic agent associated therewith. The active element may be impregnated with a therapeutic agent.

[0021] In one embodiment the apparatus comprises at least one sensor. The sensor may be used to monitor the treatment procedure. The sensor may be provided integral with an active element.

[0022] In one embodiment the device has at least one port to facilitate coupling of one or more ancillary devices. The ancillary device may comprise a needle for injecting a therapeutic agent into tissue.

[0023] In one embodiment the device is adapted for mounting to an instrument. The device may be adapted for mounting to a distal end of an instrument.

[0024] The instrument may comprise an endoscope, a laparoscope, a thoracoscope or a ureteroscope. In one case the instrument comprises a catheter.

[0025] In one embodiment the apparatus comprises a connector lumen for connecting the active element and/or the sensor in communication with a controller. The controller may be configured to be located externally of a body.

[0026] In one embodiment the first active element and the second active element are interconnected. The first active element and the second active element may be integral. In one case the first and second active elements are formed by a single electrode.

[0027] In one embodiment the apparatus comprises a receiver for mounting an instrument such as an endoscope to the head piece. The receiver may be releasably mounted or mountable to the head piece.

[0028] In one case the chamber comprises a channel extending at least partially around the chamber for drawing a vacuum through the chamber, the channel having openings through which a vacuum is drawn. The openings may be spaced-apart around the chamber.

[0029] In one embodiment the apparatus comprises the head piece, a receiver for mounting an instrument to the headpiece, and a flexible joint or connection between the head piece and the receiver.

[0030] The invention also provides an instrument comprising an apparatus of the invention such as an endoscope, a laparoscope, a thoracoscope, an ureteroscope, and/or a catheter

[0031] The invention further provides a method of prophylaxis or treatment of tissue comprising the steps of:—

[0032] providing a device of the invention;

[0033] delivering the device to a site of interest;

[0034] drawing tissue into the chamber;

[0035] applying treatment to the tissue drawn into the chamber using the at least one first active element within the chamber;

[0036] applying treatment to the tissue external of the chamber using the at least one second active element external of the chamber;

[0037] releasing the tissue from the chamber; and

[0038] withdrawing the device.

[0039] In one embodiment the tissue is drawn into the chamber by applying a vacuum. The tissue may be drawn towards the active element(s). The tissue may be drawn into contact with the active element(s).

**[0040]** In one case the method comprises the step of applying a stimulus to the tissue using the active element(s). The method may comprise the step of applying electrical energy and/or electromagnetic energy, and/or nuclear energy and/or heat energy via microwave or alternative energy source to the tissue.

**[0041]** In one embodiment the active element(s) comprises an electrode and the treatment applied to the tissue is an electroporation treatment.

**[0042]** In one case the tissue is a diseased tissue such as a tumour. The tumour may be oesophageal, colon, bladder, stomach, kidney, liver, pancreatic, fibrosarcoma, breast, prostate, glioma, lung, rectal, spleen, ovary, or melanoma type.

**[0043]** Alternatively, the tissue is a healthy tissue.

**[0044]** In one embodiment the method comprises the step of carrying out a further procedure on the tissue. The further procedure may be carried out before drawing tissue into the chamber. Alternatively or additionally the further procedure is carried out after drawing tissue into the chamber.

**[0045]** The further procedure may be a treatment procedure, and/or a visualisation procedure, and/or a drug treatment procedure, and/or a diagnostic procedure.

**[0046]** In one case the method comprises the step of coupling one or more ancillary laparoscopic devices to the device.

**[0047]** The method may comprise the step of injecting a therapeutic agent into the tissue.

**[0048]** In one case the device is mounted to or mountable to an instrument such as an endoscope, laparoscope, thoroscope, ureteroscope, and/or a catheter.

**[0049]** The device may be mounted to or mountable to a distal end of an instrument.

**[0050]** The method may comprise the step of monitoring the treatment procedure using a sensor.

**[0051]** The method may comprise the step of controlling the treatment procedure using a controller.

**[0052]** In one case the site of interest is a site on an external surface of a body. In another case the site of interest is an internal site within a body.

**[0053]** In a further aspect the invention provides a device for use in carrying out a prophylactic or treatment procedure on tissue comprising:—

**[0054]** a head piece having a receiver for receiving an instrument and a chamber for receiving tissue wherein the receiver is offset from the chamber.

**[0055]** The chamber may be at least partially translucent.

**[0056]** In a further aspect the invention provides a device for use in carrying out a prophylactic or treatment procedure on tissue comprising:—

**[0057]** a head piece having a receiver for receiving an instrument and a chamber for receiving tissue wherein the chamber is at least partially translucent.

**[0058]** In one embodiment the chamber comprises a front entrance and a rear wall opposite to the entrance, the rear wall being substantially translucent.

**[0059]** The chamber may be located distally of the receiver. In one case a longitudinal axis of the receiver is offset from the chamber entrance.

**[0060]** In one embodiment the head piece comprises a housing having a distal chamber portion and a proximal receiver portion. A longitudinal axis of the chamber portion may be offset from a longitudinal axis of the receiver portion. The housing may have a bend intermediate the chamber portion and the receiver portion.

**[0061]** In one embodiment the head piece comprises a tapered distal tip. The distal tip may be rounded.

**[0062]** In one case the proximal receiver portion is shorter than the distal chamber portion of the housing. The length of the proximal receiver portion may be less than 50% of the length of the distal chamber portion.

**[0063]** The invention further provides an apparatus for carrying out a prophylactic or treatment procedure on tissue comprising:—

**[0064]** a device of the invention;

**[0065]** at least one active element within the chamber;

**[0066]** means for drawing tissue into the chamber; and

**[0067]** means for applying a treatment to tissue drawn into the chamber.

**[0068]** The means for drawing tissue into the chamber may comprise means for applying a vacuum to tissue. In one case the apparatus comprises a vacuum lumen for connecting the chamber in communication with a vacuum source. The apparatus may comprise one or more vacuum orifices for connecting the vacuum lumen in communication with the chamber.

**[0069]** In one case the vacuum source is configured to be located externally of a body.

**[0070]** The longitudinal axis of the vacuum lumen may be offset radially from the longitudinal axis of the chamber.

**[0071]** The means for drawing tissue into the chamber may be configured to draw tissue towards the active element. The means for drawing tissue into the chamber may be configured to draw tissue into contact with the active element.

**[0072]** In one case the active element comprises an electrode.

**[0073]** The means for applying treatment may comprise means for applying electroporation to tissue in the chamber.

**[0074]** In one case the active element comprises a conductive element.

**[0075]** The active element may comprise an optical element and/or a radiation source and/or an ultrasound source.

**[0076]** The apparatus may comprise at least two active elements.

**[0077]** At least some of the active elements are the same. Alternatively at least some of the active elements are different.

**[0078]** In one embodiment at least one active element has a therapeutic agent associated therewith. The active element may be impregnated with a therapeutic agent.

**[0079]** The location of the active elements in the chamber may be configured to minimise the variation in intensity of the physical field within the chamber.

**[0080]** In one embodiment the apparatus comprises

**[0081]** at least one first active element located within the chamber; and

**[0082]** at least one second active element located externally of the chamber.

**[0083]** At least one first active element may comprise an electrode.

**[0084]** At least one second active element may comprise an electrode.

**[0085]** There may be two first electrodes within the chamber. The first electrodes may be located on opposed sides of the chamber.

**[0086]** In one case there are two second electrodes outside of the chamber. The electrodes may be located on opposite sides of the entrance to the chamber.



[0087] The apparatus may comprise means for applying electroporation to tissue located in the chamber and/or means for applying electroporation to tissue located outside of the chamber.

[0088] The apparatus may comprise at least one sensor. The sensor may be used to monitor the treatment procedure.

[0089] The sensor may be provided integral with the active element.

[0090] In one embodiment the head piece has at least one port to facilitate coupling of an ancillary device to the head piece.

[0091] The ancillary device may comprise a needle for injecting a therapeutic agent into tissue.

[0092] In one embodiment the apparatus comprises an instrument located in the receiver. The instrument may comprise an endoscope, a laparoscope, a thoracoscope, a ureteroscope and/or a catheter.

[0093] In one case the apparatus comprises a connector lumen for connecting the active element and/or the sensor in communication with a controller. The controller may be configured to be located externally of a body.

[0094] In a further aspect the invention provides a device for use in carrying out a prophylactic or treatment procedure on tissue comprising:—

[0095] a head piece having a chamber for receiving tissue wherein the head piece is at least partially flexible for navigating tortuous passageways and/or obstructions.

[0096] In one case the head piece is of a flexible material. The head piece may be of a foam material.

[0097] In one case the head piece is of a polyurethane material.

[0098] The device may comprise at least one active element. The active element may be flexible to conform with the head piece. In one case the active element comprises an electrode.

BRIEF DESCRIPTION OF THE DRAWINGS

[0099] The invention will be more clearly understood from the following description of some embodiments thereof, given by way of example only, with reference to the accompanying drawings, in which:

[0100] FIG. 1 is a perspective view of a head piece for use in carrying out a prophylactic or treatment procedure on tissue;

[0101] FIG. 2 is a top plan view of the head piece of FIG. 1;

[0102] FIG. 3 is a side elevational view of the head piece;

[0103] FIG. 4 is an end view of the head piece;

[0104] FIG. 5 is an elevational view of the head piece with an endoscope in position;

[0105] FIG. 6 is a perspective view of another head piece according to the invention;

[0106] FIG. 7 is a perspective, partially cut-away view of the head piece of FIG. 6;

[0107] FIGS. 8, 9 and 10 are respectively top plan, side elevational and end views of the head piece of FIGS. 6 and 7;

[0108] FIGS. 11 and 12 are diagrams illustrating the electrical field generated using the device;

[0109] FIG. 13 is a perspective view of a device according to the invention attached to an operating shaft;

[0110] FIG. 14 is an exploded view of part of the device of FIG. 13;

[0111] FIG. 15 is an enlarged perspective view of a head part of the device of FIGS. 13 and 14;

[0112] FIG. 16 is a perspective view of the underside of the head part;

[0113] FIG. 17 is a diagram of part of the head piece of the device showing vacuum flow;

[0114] FIG. 18 is a perspective view of electrodes for a head piece;

[0115] FIG. 19 is a partial view of the electrodes of FIG. 18 in position in a head piece;

[0116] FIGS. 20 and 21 are diagrams of another device of the invention; and

[0117] FIGS. 22 to 26 are perspective views of other head pieces.

DETAILED DESCRIPTION

[0118] Referring to the drawings and initially to FIGS. 1 to 5 thereof there is illustrated an apparatus according to the invention which is suitable for carrying out a prophylactic or treatment procedure on tissue.

[0119] The apparatus comprises a head piece 1 having a receiver 2 for receiving an instrument such as an endoscope 10 and a chamber 3 for receiving tissue. It will be noted that the receiver 2 is offset from the chamber 3. The chamber 3 is at least partially translucent to facilitate visualisation of the chamber 3 using the endoscope 10.

[0120] In this case the chamber 3 comprises a front entrance 5 and a rear wall 6 opposite to the entrance 5. The rear wall 6 is translucent and may for example, be of a suitable translucent plastics material.

[0121] The chamber 3 is located distally of the receiver 2. Longitudinal axes through the receiver 2 and chamber 3 are offset and there is a bend or transition region 7 between the receiver 2 and the housing 3. The overall length of the head piece is minimised.

[0122] The device has a number of active treatment elements. In this case there are two active treatment elements in the form of planar electrodes 11 on opposite sides of the chamber 3. The device also has a vacuum lumen (not shown) for drawing tissue into the chamber 3 through the entrance 5. A vacuum is applied through the vacuum lumen to apply a vacuum to tissue and to draw the tissue into the chamber 5 and into contact with the electrodes 11.

[0123] In this case each active element is provided in the form of a rigid planar member fixedly attached to the interior wall of the chamber 5. Each active element comprises an electrode 11 for applying an electroporation treatment to tissue drawn into the chamber 5.

[0124] In use, the head piece is mounted to an instrument 10 and the instrument 10 is advanced to a desired site of interest within the body. A vacuum is then applied using a vacuum source externally of the body. The vacuum draws the tissue into the chamber 3 and into contact with the active elements 11. When tissue is drawn into the chamber 3 a surgeon can see it through the rear wall 6 and can confirm appropriate engagement with the tumour.

[0125] The electrodes 11 are used to apply an electroporation treatment to the tissue in the chamber 3.

[0126] The device attaches to the head of an endoscope 10 and draws tumour tissue into a chamber 3 under vacuum pressure. An electrical field is generated around the tumour which ensures the tissue becomes porous. A therapeutic agent such as a chemotherapeutic macromolecule, for example bleomycin may then be delivered to the tissue. The device may incorporate a local injector such as one or more needles to deliver the therapeutic agent to the tissue. Thus, passive

diffusion of a locally present therapeutic agent is facilitated. Absorption occurs only in the area that has been electroporated and therefore is targeted to the tumour, leaving surrounding healthy tissues unaffected. One of the significant advantages of the system is that healthy cells and tissues surrounding the tumour can be treated to a greater degree than conventional ablation methods e.g. radiotherapy and radiofrequency ablation.

[0127] Some advantages of the invention are:

[0128] speed of application: pulses are delivered in 1 msec;

[0129] targeted delivery: drug adsorption is localised to the area treated by the device, only a fraction of drug used compared to standard (therefore less side effects for patient);

[0130] healthy tissue: studies to date indicate that healthy tissue is significantly less affected than tumour tissue allowing wider margins around the tumour to be treated, thereby decreasing the potential risk of recurrence;

[0131] repeatable: treatment can be delivered multiple times if required;

[0132] minimally invasive and non-toxic: the dose of drug is less than 1% of that used in conventional chemotherapy—endoscopic application allows for a greater number of patients to receive treatment;

[0133] unlike ablation methods the method of cell death is apoptotic, not an inflammatory, necrotic response;

[0134] new therapeutics: future potential for the device to be used for gene therapy;

[0135] the endoscopic application and electroporation treatment can be applied with the patient under sedation and can be completed on an outpatient basis;

[0136] the technology is complementary to existing therapies, is easy to perform and is relatively inexpensive;

[0137] many solid tumours may be accessed through body orifices without the need for surgical intervention.

[0138] The invention provides an endoscopic attachment for use in the minimally invasive treatment of gastrointestinal cancers such as colorectal and oesophageal cancers. Colorectal cancer is not adequately addressed by existing therapies. Oesophageal cancer is the fastest growing cancer in the western world and 60% of patients are deemed unsuitable for surgical treatment. The device of the invention can however be used to treat such tumours. In clinical practice an electric field is applied to the tumour followed by the delivery of electroporation pulses. The treatment duration is approximately 1 msec per application, which is significantly quicker than radiofrequency ablation or other thermal ablation methods.

[0139] During the treatment procedure, sensors may be used to enable the user to monitor the progress of the treatment procedure. The progress of the treatment procedure may be controlled using the controller.

[0140] When the treatment procedure is completed the vacuum is released to release the tissue from within the chamber 3 and the apparatus is retrieved from the body by withdrawing the instrument 10.

[0141] A further procedure may be carried out on the tissue before and/or after drawing tissue into the chamber 3. Possible further procedures include a treatment procedure, a visualisation procedure, a drug treatment procedure, or a diagnostic procedure.

[0142] The apparatus of the invention is suitable for treating a diseased tissue, such as a tumour. The tumour may be oesophageal, colon, bladder, stomach, kidney, liver, pancreatic, fibrosarcoma, breast, prostate, glioma, lung, rectal, spleen, ovary or melanoma type.

[0143] The apparatus of the invention is also suitable for carrying out a prophylactic treatment on healthy tissue.

[0144] The site of interest may be an internal site within body, or an external site on an external surface of the body.

[0145] The location of the active elements 11 within the chamber 5 is chosen to minimise the variation in intensity of the electric field within the chamber 5. In this manner, the device achieves a substantially homogenous physical field throughout the chamber 5.

[0146] A distal end 15 of the device is substantially rounded. In this way the device defines a smooth crossing profile.

[0147] The apparatus may be mounted to an instrument for delivery to a site of interest in a body and subsequent retrieval from the body. Typically the apparatus will be mounted to the distal end of an instrument. Suitable instruments to which the apparatus may be mounted include an endoscope, a laparoscope, a thoracoscope, a ureteroscope, a catheter.

[0148] Referring to FIGS. 6 to 10 there is illustrated another apparatus according to the invention which is similar to the device of FIGS. 1 to 5 and like parts are assigned the same reference numerals.

[0149] In this case there is at least one first active element such as an electrode 11 located within the chamber 3 and at least one second active element located externally of the chamber. In this instance there are two second electrodes 25 located on opposite sides of the entrance 5 into the chamber 3. The additional electrodes 25 on the outside of the chamber 3 improve the electrical field distribution. The voltage applied to the inner and outer electrodes can be varied independently. For example, to optimise field distribution the voltage applied to the outer electrodes 25 may be about three times larger than the voltage applied to the inner electrodes 11. The outside electrodes 25 may be of any suitable shape.

[0150] In the device described with reference to FIGS. 1 to 5 the electrical field generated by the device with two plate parallel electrodes 11 contained within the device is largely kept within the chamber. However with two additional electrodes 25 (wired separately) and placed on the outside of the chamber as illustrated in FIGS. 6 to 10 (somewhat like a pair of skis) a larger volume of tissue can be treated by targeting the tissue underlying the device. This would be particularly suitable for colorectal cancers.

[0151] Referring to FIGS. 11 and 12 the electric field generated by a device with inner chamber electrodes (FIG. 11) and with outer electrodes (FIG. 12) for deeper tissue penetration is illustrated. In (FIG. 11) with the electrodes 11 positioned parallel on both sides of the vacuum chamber, the electric field distribution inside is almost completely homogenous. The electric field is mostly limited to the chamber itself and does not protrude more than a few millimetres outside. Typically, 5 mm outside the chamber the electric field is ten times less than in the middle of chamber. With the electrodes 25 placed external of the device a field is generated which is dependent on the voltage applied and is capable of effectively electroporating tissue lying under the device.

[0152] The standard electroporation pulse parameters employed are typically in the region of at least 0.1 msec and up to several msec in length and with a frequency of at least 1

Hz. Standard electroporation typically consists of eight 0.1 msec pulses for a single treatment application to facilitate drug delivery.

[0153] The voltage applied for skin based application is in the range of 1000 to 13000 v/cm. For intraluminal application the required voltage can be reduced to under 1000 v/cm but typically should be greater than 500 v/cm.

[0154] In this device we have the possibility to apply two distinct electroporation pulse parameters to the tissue within the chamber and positioned directly under the chamber. In the first instance an electrical pulse is delivered between the two plate electrodes **11** of a specific voltage, pulse length and frequency. In the second instance a higher or lower voltage, pulse length and frequency can be applied to the external electrodes **25** which can be determined by the depth of tissue the clinician/operation intends to treat. A higher voltage will increase the surface area affected by the electrical field but will be allowable up to a maximum voltage that has been determined not to cause significant necrotic damage to tissue surrounding the electrode or to the patient.

[0155] Referring to FIGS. **13** to **19** there is illustrated another device **50** according to the invention, in which parts similar to those described in other drawings are assigned the same reference numerals. The device **50** comprises a head piece **51** with a conduit **52** extending therefrom. The conduit **52** provides a lumen for passage of vacuum and electrical connections. The conduit **52** is connected to a junction **53** which has a first and second conduits **54**, **55** extending therefrom.

[0156] The first conduit **54** leads the electrical connectors to a distal connector **56** for connection with a source of electrical power. The second conduit **55** has a distal port **57** for connection to a vacuum source. It will be appreciated that these aspects in particular may be utilised with any of the head pieces described herein.

[0157] The head piece **51** of the device **50** is releasably mounted to a receiver **60** for an endoscope. The receiver **60** is releasably mounted, in this case by connections **62**, **64**, (such as tongue and groove and/or snap fit projections) to the head pieces **51**. The receiver comprises a ring element **63** into which an endoscope is mounted. The ring element **63** may be of a flexible material to facilitate mounting of an endoscope. By providing a range of receivers **60** a wide range of different endoscopes can be mounted to the headpiece **51**. This greatly enhances the application of the device to a wide range of different endoscopes. Again, this aspect can also be applied to any of the headpiece designs described herein.

[0158] Referring in particular to FIGS. **20** and **21** in this case there are two electrodes **70**, **71** each of which comprises a planar part **72** which is located within the chamber of the headpiece **51** and an out-turned lip part **73** which extends around the edge of the chamber so that portions of the electrodes are external to the chamber. This is similar to the arrangement of the skid-type electrodes described with reference to FIGS. **5** to **11**. The lipped electrodes **70**, **71** can be used in situations where it is not necessary to independently vary the power supplied to internal and external electrodes.

[0159] The electrodes **70**, **71** have bendable tabs **76** for ease of mounting and electrical connection.

[0160] FIGS. **13** to **19** also illustrate another aspect which may be applied to any of the devices described herein. The vacuum is drawn on the chamber through an inlet channel **80** which extends from the vacuum lumen around the back and side walls of the chamber. The chamber has a plurality of exit

openings **85** into the vacuum channel **80** to distribute the applied vacuum around the chamber and thereby reducing the risk of the vacuum path becoming blocked, in use. In this case the openings **85** are defined between castellations **86**. Each individual opening **85** also provides a filter to prevent larger debris from being drawn into the vacuum line. The arrangement also facilitates even sealing/filling of the chamber with tissue as vacuum is acting on the tissue from a plurality of locations around the chamber.

[0161] The device can be at least partially flexible for navigating tortuous passageways and/or obstructions. One example is illustrated in FIGS. **20** and **21**. For example, such a device could be used to navigate around bends such as the epiglottis. The device may include a flexible joint **90**. The joint may comprise a flexible material, for example a foam material such as polyurethane.

[0162] FIGS. **22** to **26** illustrate various alternative head pieces which are similar to those described above and like parts are assigned the same reference numerals. Whilst there are some advantages associated with these head pieces in general they are not as advantageous as those of the devices of FIGS. **1** to **10** in terms of size, profile and/or visualisation.

[0163] It will be appreciated that various features described and/or illustrated with reference to an embodiment of the invention can be readily used in any of the other embodiments.

[0164] The invention is not limited to the embodiments hereinbefore described, with reference to the accompanying drawings, which may be varied in construction and detail.

**1-142.** (canceled)

**143.** An apparatus for use in carrying out a prophylactic or treatment procedure on tissue comprising:—

- a head piece having a chamber with an entrance for receiving tissue;
- at least one first active element located within the chamber;
- and
- at least one second active element located externally of the chamber.

**144.** The apparatus as claimed in claim **143** wherein at least one first active element comprises an electrode.

**145.** The apparatus as claimed in claim **143** wherein at least one second active element comprises an electrode.

**146.** The apparatus claimed in claim **143** comprising two first electrodes within the chamber.

**147.** The apparatus as claimed in claim **146** wherein the first electrodes are located on opposed sides of the chamber.

**148.** The apparatus as claimed in claim **143** comprising two second electrodes outside of the chamber.

**149.** The apparatus as claimed in claim **148** wherein the electrodes are located on opposite sides of the entrance to the chamber.

**150.** The apparatus as claimed in claim **143** comprising means for applying electroporation to tissue located in the chamber.

**151.** The apparatus as claimed in claim **143** comprising means for applying electroporation to tissue located outside of the chamber.

**152.** The apparatus as claimed in claim **143** comprising a vacuum lumen for connecting the chamber in communication with a vacuum source.

**153.** The apparatus as claimed in claim **143** wherein the longitudinal axis of the vacuum lumen is offset radially from the longitudinal axis of the chamber.

**154.** The apparatus as claimed in claim **143** wherein at least one active element has a therapeutic agent associated therewith.

**155.** The apparatus as claimed in claim **143** wherein the chamber comprises a channel extending at least partially around the chamber for drawing a vacuum through the chamber, the channel having openings through which a vacuum is drawn.

**156.** The apparatus as claimed in claim **143** comprising the head piece, a receiver for mounting an instrument to the headpiece, and a flexible joint or connection between the head piece and the receiver.

**157.** The method of prophylaxis or treatment of tissue comprising the steps of:—

- providing a device as claimed in claim **143**;
- delivering the device to a site of interest;
- drawing tissue into the chamber;
- applying treatment to the tissue drawn into the chamber using the at least one first active element within the chamber;
- applying treatment to the tissue external of the chamber using the at least one second active element external of the chamber;

releasing the tissue from the chamber; and withdrawing the device.

**158.** A device for use in carrying out a prophylactic or treatment procedure on tissue comprising:—  
a head piece having a receiver for receiving an instrument and a chamber for receiving tissue wherein the receiver is offset from the chamber.

**159.** A device for use in carrying out a prophylactic or treatment procedure on tissue comprising:—  
a head piece having a receiver for receiving an instrument and a chamber for receiving tissue wherein the chamber is at least partially translucent.

**160.** The apparatus for carrying out a prophylactic or treatment procedure on tissue comprising:—  
a device as claimed in claim **143**;  
at least one active element within the chamber;  
a vacuum lumen for drawing tissue into the chamber; and  
means for applying a treatment to tissue drawn into the chamber.

**161.** A device for use in carrying out a prophylactic or treatment procedure on tissue comprising:—  
a head piece having a chamber for receiving tissue wherein the head piece is at least partially flexible for navigating tortuous passageways and/or obstructions.

\* \* \* \* \*