



(19) **United States**

(12) **Patent Application Publication**
Melikyan et al.

(10) **Pub. No.: US 2020/0145123 A1**

(43) **Pub. Date: May 7, 2020**

(54) **METHODS AND APPARATUS FOR TUNING OPTICAL MICRORING DEVICES**

(52) **U.S. Cl.**
CPC *H04J 14/0283* (2013.01); *G02F 1/011* (2013.01); *H04B 2001/1072* (2013.01); *H04B 1/0475* (2013.01); *H04B 1/1027* (2013.01)

(71) Applicant: **Nokia Solutions and Networks OY**, Espoo (FI)
(72) Inventors: **Argishti Melikyan**, Matawan, NJ (US); **Po Dong**, Morganville, NJ (US)

(57) **ABSTRACT**
An optical system having a plurality of ring resonators that can be tuned by regulating their local temperatures in a manner that enables: initial spectral alignment of the optical resonances with the desired carrier wavelengths; fine-tuning of the ring resonators to spectrally align a selected feature of the optical resonances with the carrier wavelengths; and continuous tuning of the ring resonators to counter any detuning thereof during operation. The initial spectral alignment can be performed using intensity/frequency modulation of different carrier wavelengths with different respective frequencies and detection of said frequencies in the photo-currents generated by the individual ring resonators under reverse-bias conditions. After the initial spectral alignment, the ring resonators can be tuned by dithering the local temperatures and then using frequency decomposition of the feedback signal generated by a single photodiode coupled to the optical bus waveguide downstream from the ring resonators to adjust the heater voltages.

(73) Assignee: **Nokia Solutions and Networks OY**, Espoo (FI)

(21) Appl. No.: **16/183,261**
(22) Filed: **Nov. 7, 2018**

Publication Classification

(51) **Int. Cl.**
H04J 14/02 (2006.01)
G02F 1/01 (2006.01)
H04B 1/10 (2006.01)
H04B 1/04 (2006.01)

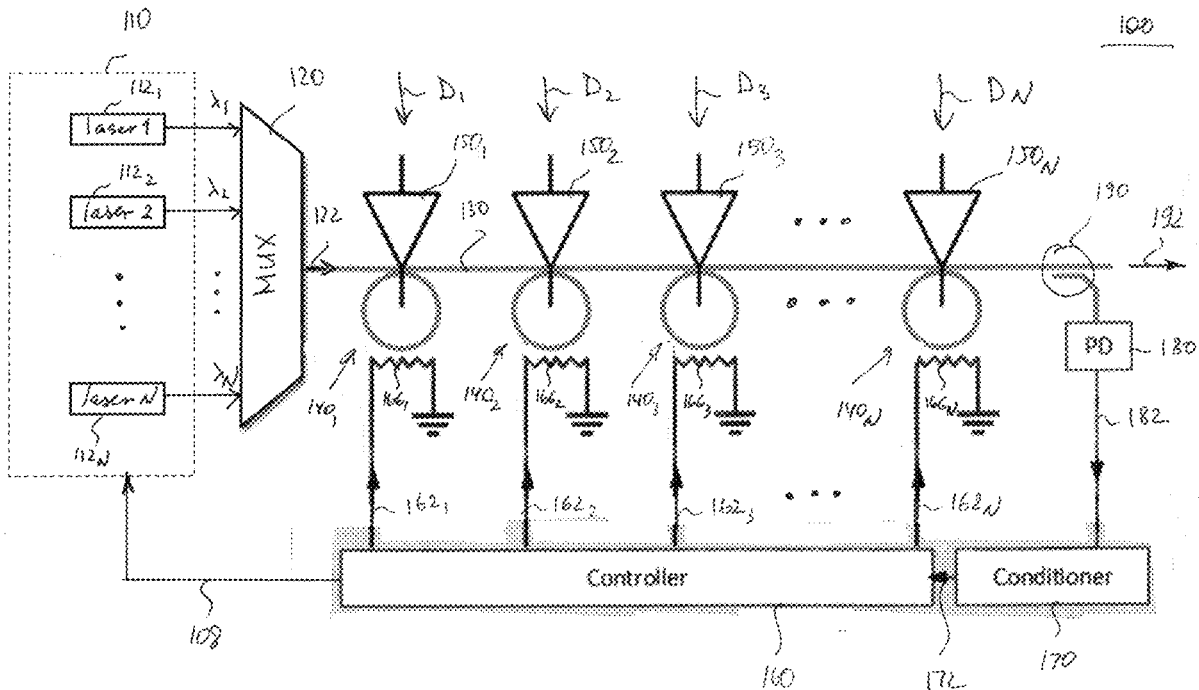

FIG. 2A

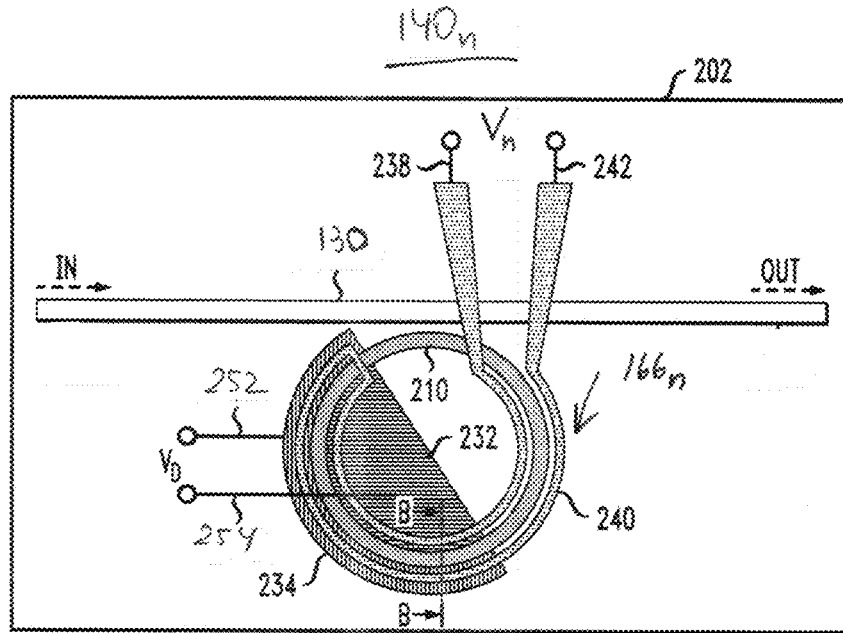

FIG. 2B

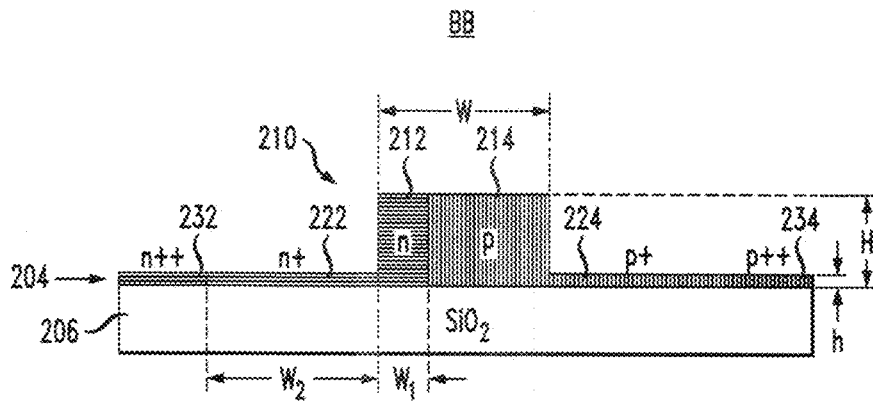

Fig. 3

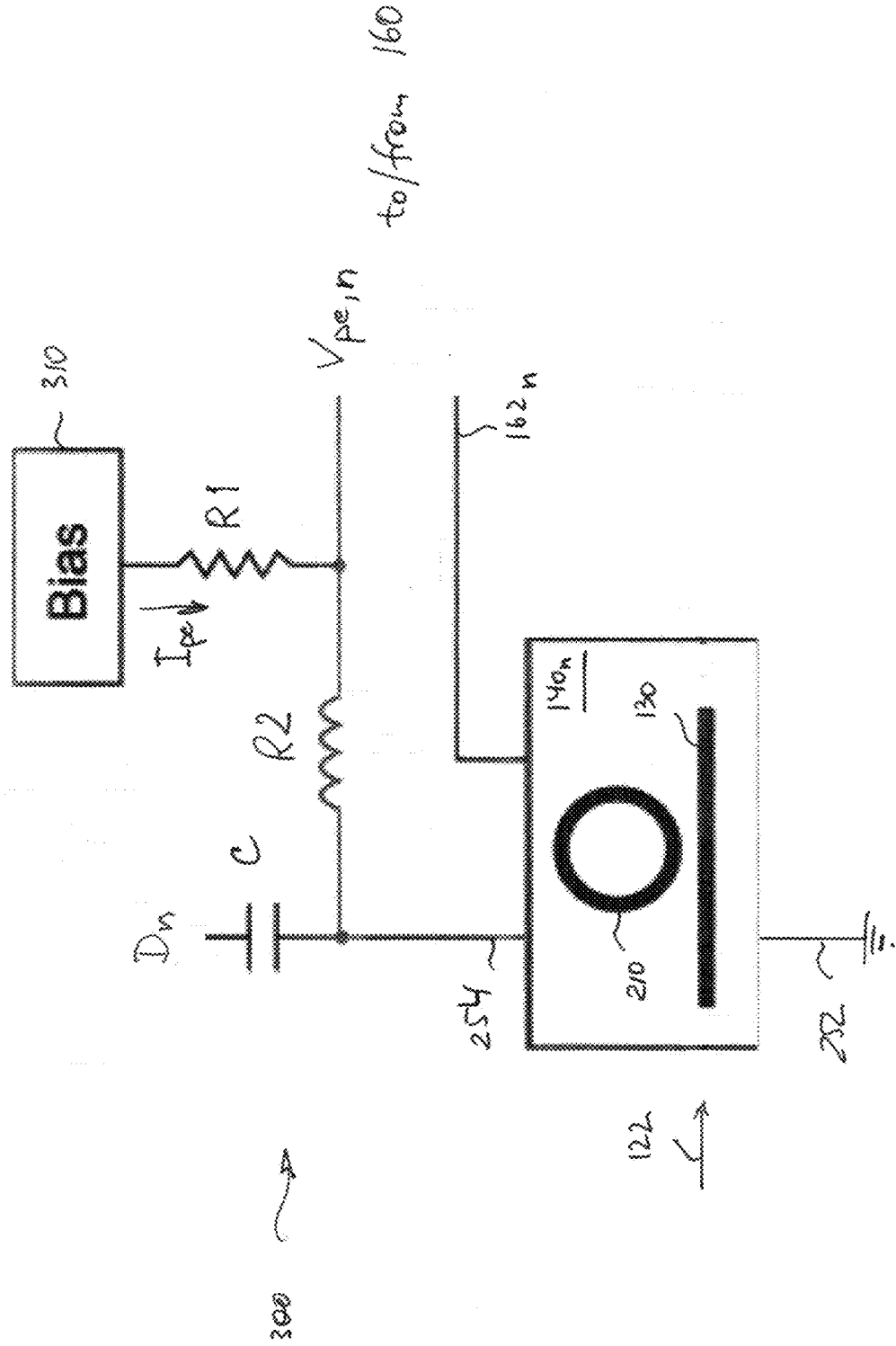

Fig. 4
400

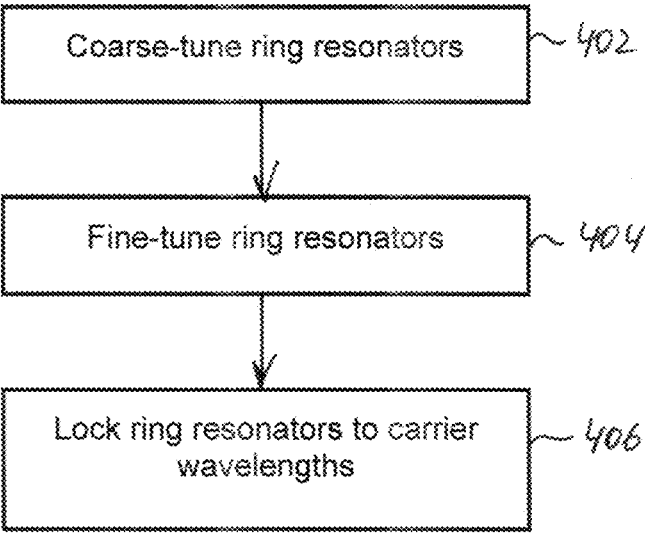

Fig. 5
500

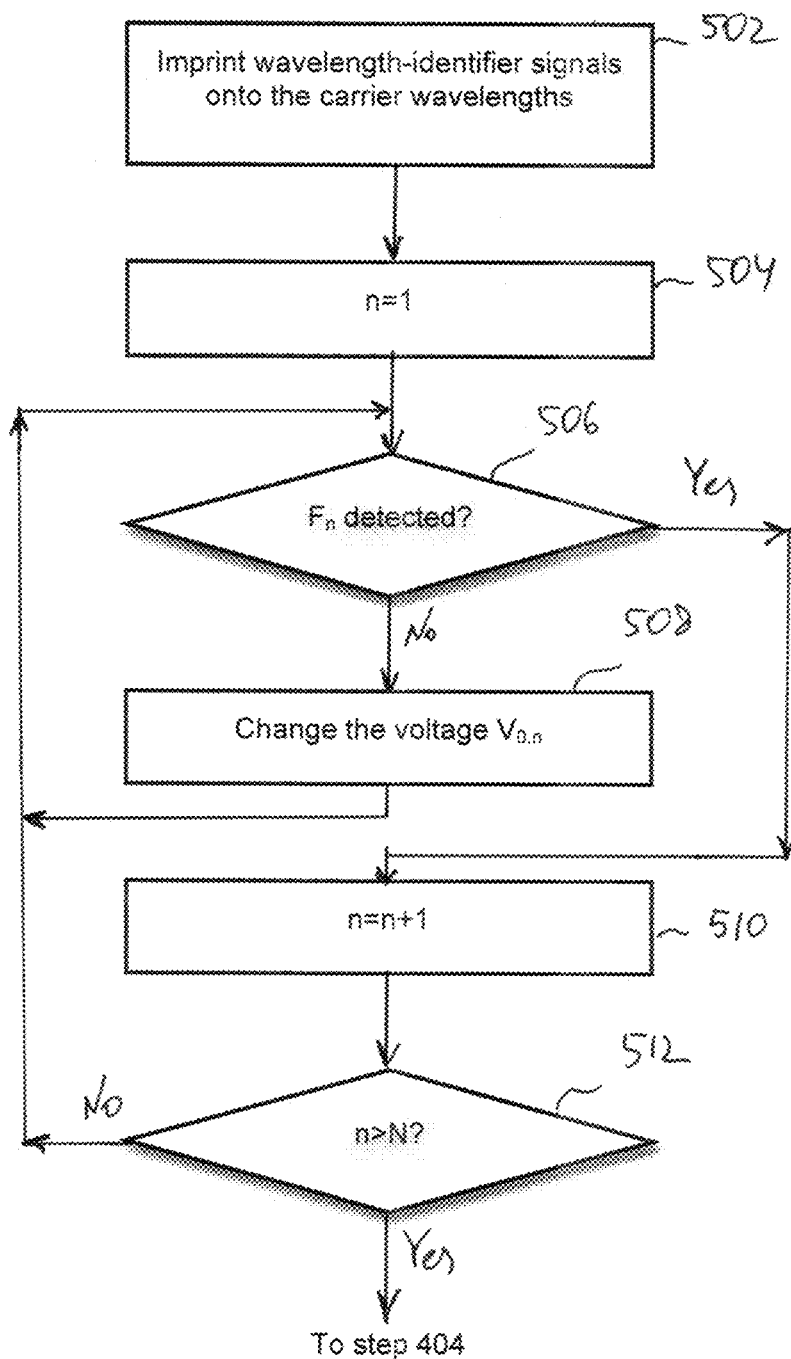

Fig 6
600

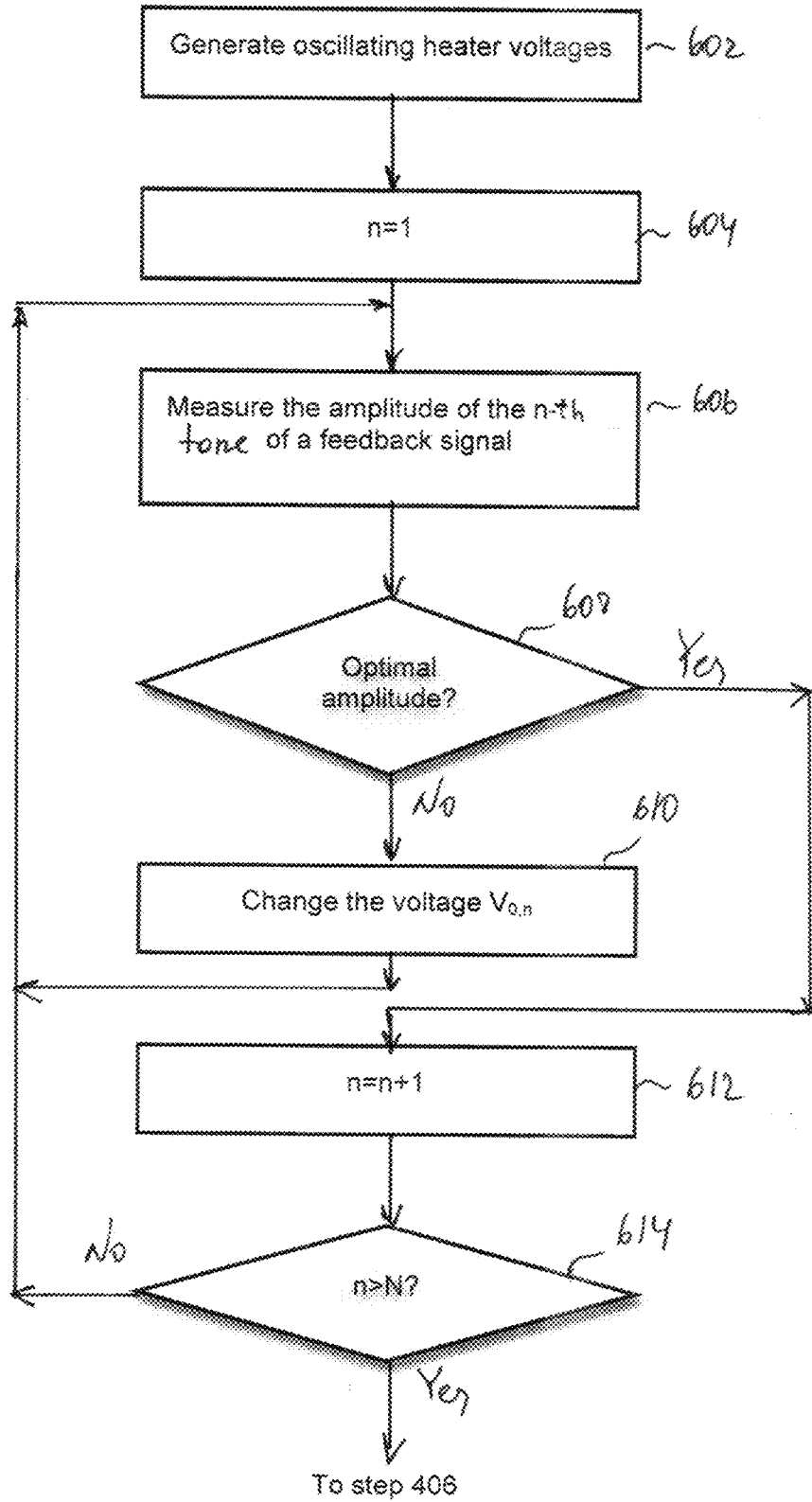

Fig. 7

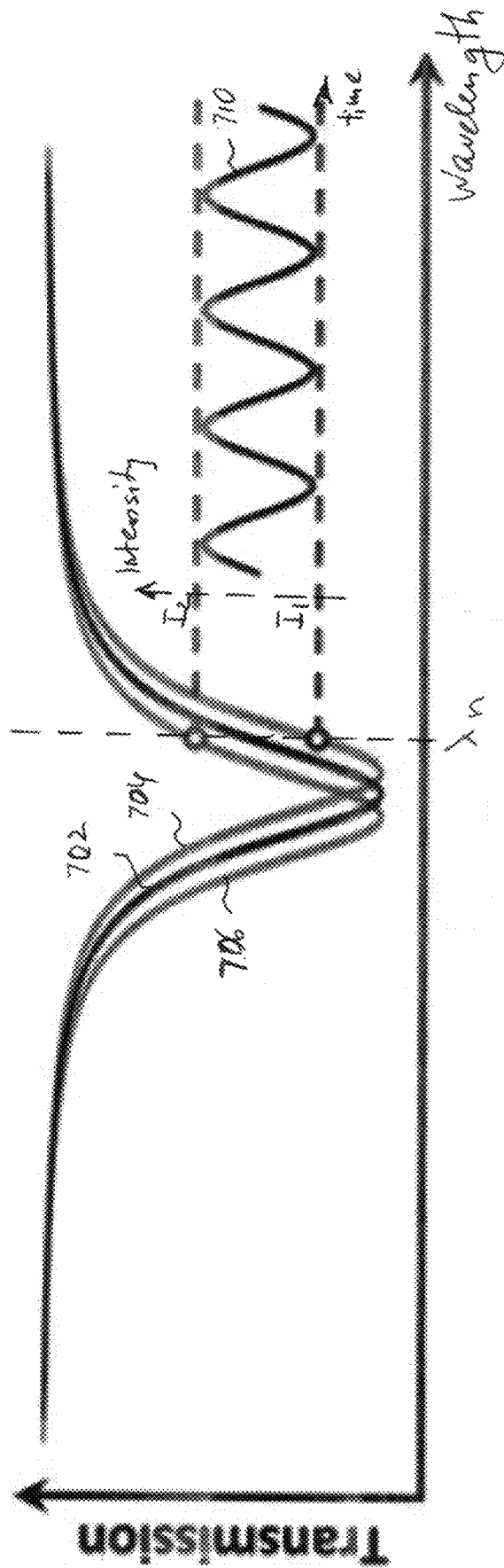

Fig. 8

800

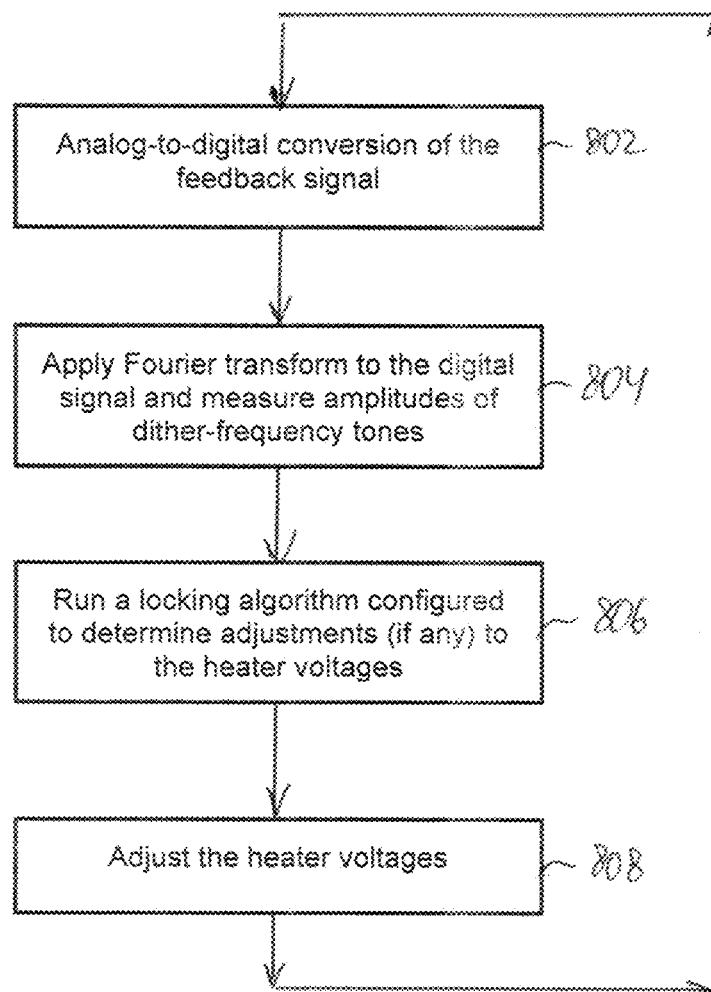

Fig. 9
900

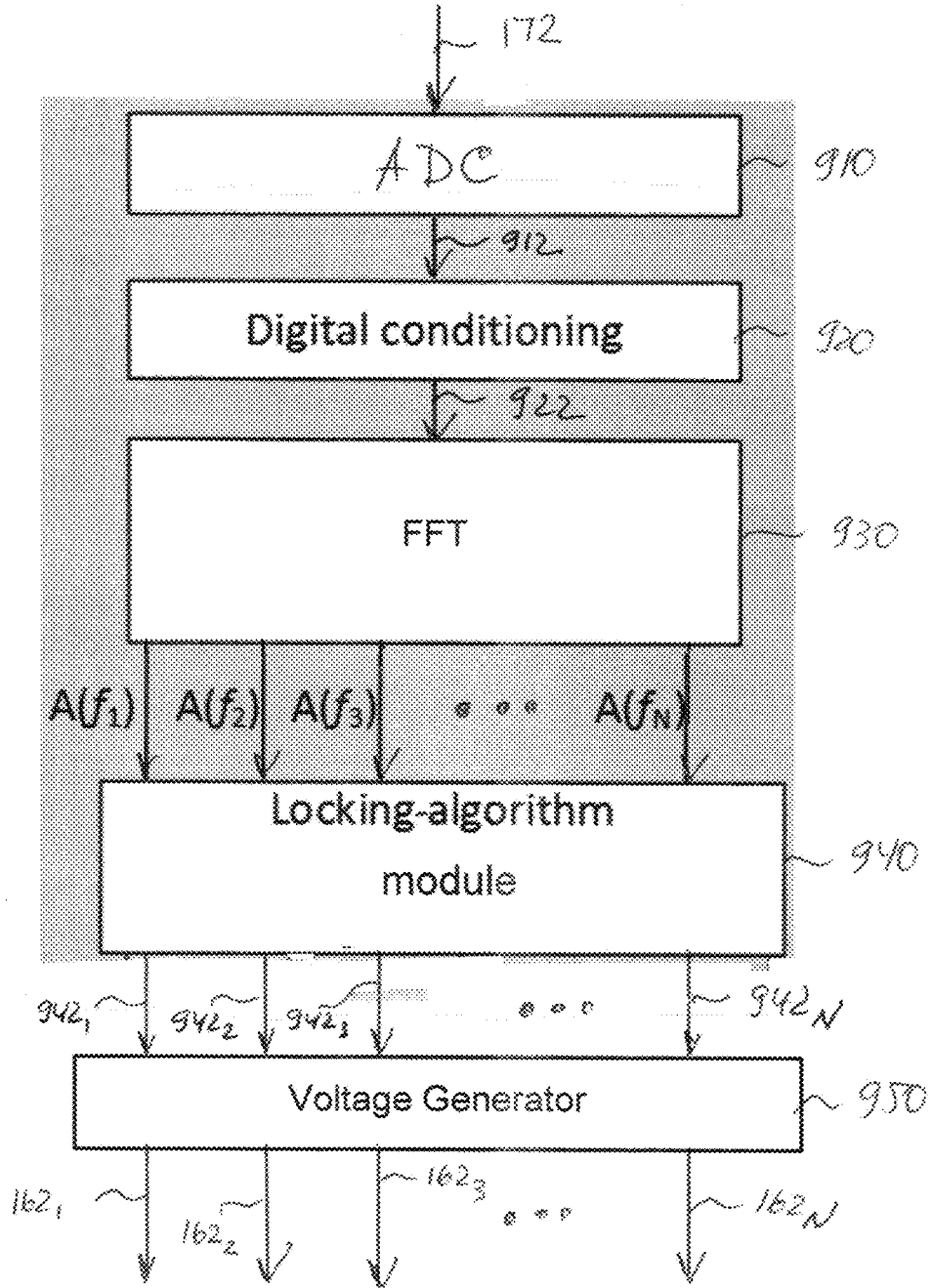

Fig. 10
1000

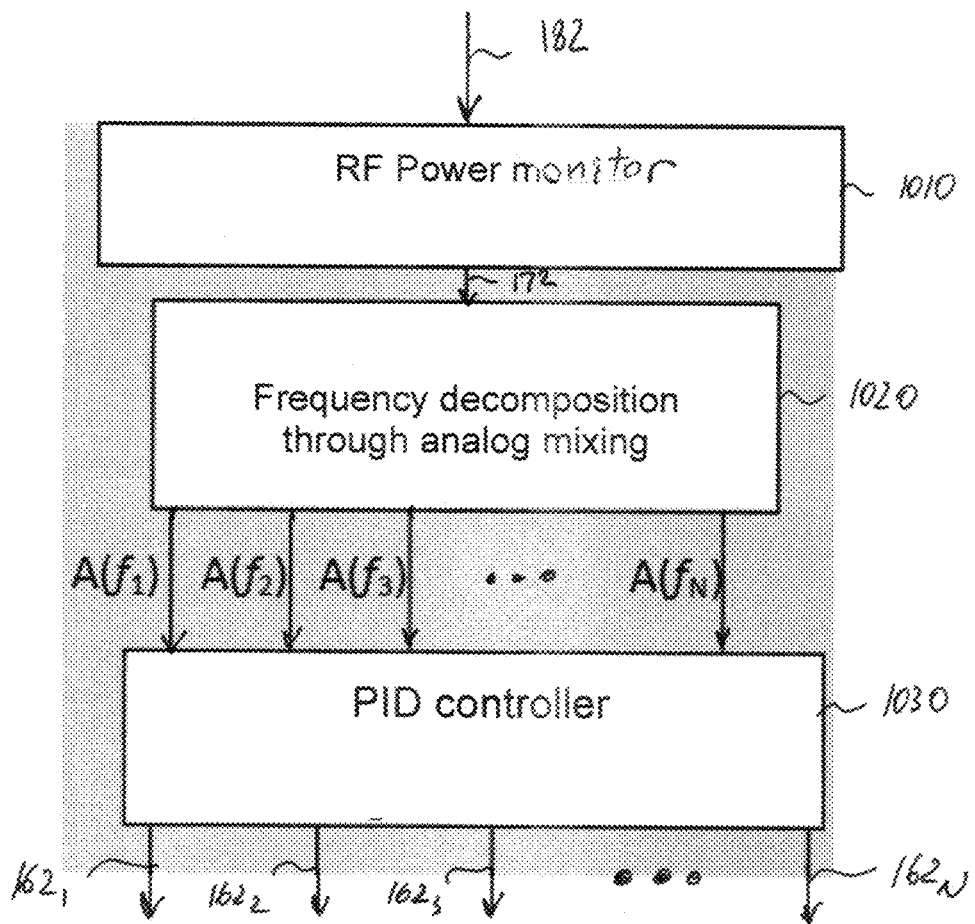
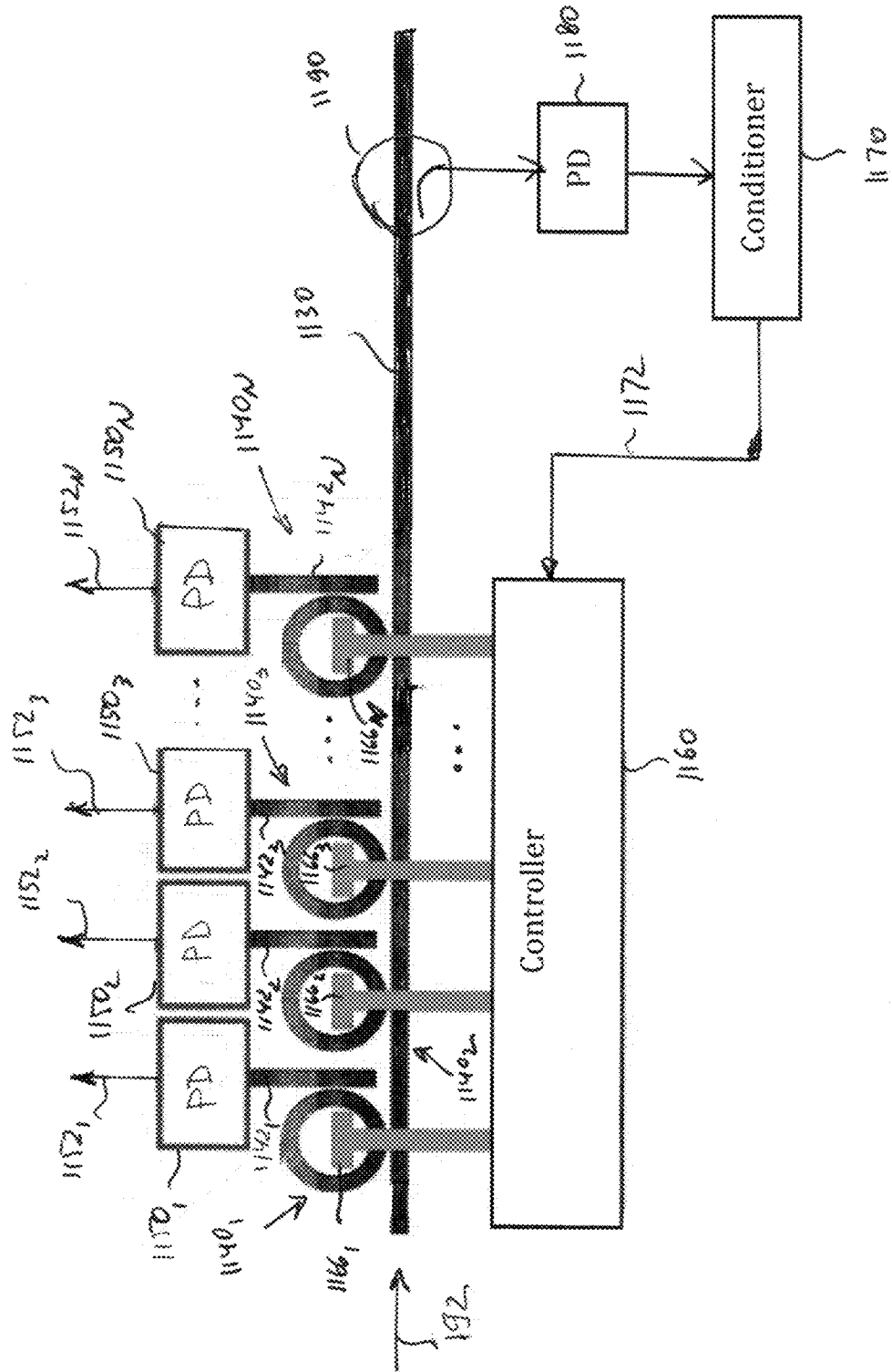

Fig. 11
1100



METHODS AND APPARATUS FOR TUNING OPTICAL MICRORING DEVICES

BACKGROUND

Field

[0001] Various example embodiments relate to optical communication equipment and, more specifically but not exclusively, to methods and apparatus for tuning optical microring devices.

Description of the Related Art

[0002] This section introduces aspects that may help facilitate a better understanding of the disclosure. Accordingly, the statements of this section are to be read in this light and are not to be understood as admissions about what is in the prior art or what is not in the prior art.

[0003] Microring devices can be used to implement a variety of photonic components (e.g., optical modulators, wavelength filters, optical switches, etc.) with desirable performance metrics, such as a small physical size, low power consumption, etc. Some microring-based silicon modulators can provide high modulation speeds (e.g., >10 Gbit/s) and are compatible with low-voltage (e.g., CMOS) driving circuits. These and other characteristics can make the microring devices very attractive, e.g., for use in massively parallel, high-speed optical networks.

SUMMARY OF SOME SPECIFIC EMBODIMENTS

[0004] Practical use of some microring devices may be hampered by their relatively high susceptibility to manufacturing imperfections and thermal fluctuations, e.g., due to the high thermo-optic coefficient of some constituent materials, such as silicon, and/or the resonant behavior of the microring. For example, to register and lock a microring with a corresponding laser wavelength, resonance adjustment may need to be performed to compensate the static resonant-frequency offset caused by the manufacturing-process variances and/or to track and cancel the dynamic resonant-frequency changes induced, e.g., by temperature fluctuations.

[0005] At least some embodiments disclosed herein address these and possibly other related problems in the state of the art by providing an optical system having a plurality of microring devices that can be tuned by regulating their local temperatures in a manner that enables (i) initial spectral alignment of the optical resonances with the desired carrier wavelengths of the WDM multiplex, (ii) fine-tuning of the microring devices to spectrally align a selected feature (e.g., an edge) of the optical resonances with the carrier wavelengths, and (iii) continuous tuning of the microring devices to counter any detuning thereof that might occur during operation. In an example embodiment, the initial spectral alignment can be performed using shallow intensity modulation or slight frequency modulation (chirp) of the different carrier wavelengths with different respective frequencies and subsequent detection of said frequencies in the photocurrents generated by the constituent semiconductor diodes of the individual microring devices under reverse-bias conditions. After the initial spectral alignment, the microring devices can be tuned by dithering the local temperatures and then using frequency decomposition of the

feedback signal generated by a single photodiode coupled to the optical bus waveguide downstream from the microring devices to appropriately adjust the heater voltages.

[0006] Different embodiments can advantageously be used for tuning WDM transmitters and/or WDM receivers.

[0007] According to an example embodiment, provided is an apparatus comprising: a plurality of optical ring resonators optically coupled to an optical waveguide at respective locations along the optical waveguide; a plurality of heaters, each of the heaters being located at a respective one of the optical ring resonators; a photodetector optically coupled to the optical waveguide downstream from the respective locations; and an electronic controller being configured to: regulate the plurality of heaters in response to an electrical output signal generated by the photodetector while electrical drive signals of the heaters are being dithered in amplitude; and dither the electrical drive signals of different ones of the heaters with different respective frequencies.

[0008] According to another example embodiment, provided is an apparatus comprising: a light source configured to transmit a plurality of carrier wavelengths through an optical waveguide, each of the carrier wavelengths being modulated at a different respective frequency; a plurality of optical ring resonators optically coupled to the optical waveguide at respective locations along the optical waveguide to receive the plurality of carrier wavelengths, each of the optical ring resonators comprising a respective optical waveguide loop that includes at least a portion of a respective semiconductor diode capable of generating a respective photocurrent in response to light in said respective optical waveguide loop; a plurality of heaters, each of the heaters being located to heat a respective one of the optical ring resonators; and an electronic controller configured to regulate the plurality of heaters in response to detecting at least some of said respective frequencies in the respective photocurrents.

[0009] According to yet another example embodiment, provided is an apparatus comprising: a plurality of optical ring resonators optically coupled to an optical waveguide at respective locations along the optical waveguide; a plurality of phase shifters, each of the phase shifters being in a respective one of the optical ring resonators; a photodetector optically coupled to the optical waveguide downstream from the respective locations; and an electronic controller being configured to: regulate the plurality of phase shifters in response to an electrical output signal generated by the photodetector while electrical drive signals of the phase shifters are being dithered in amplitude; and dither the electrical drive signals of different ones of the phase shifters with different respective frequencies.

BRIEF DESCRIPTION OF THE DRAWINGS

[0010] Other aspects, features, and benefits of various disclosed embodiments will become more fully apparent, by way of example, from the following detailed description and the accompanying drawings, in which:

[0011] FIG. 1 shows a block diagram of an optical transmitter according to an embodiment;

[0012] FIGS. 2A-2B show schematic diagrams of a ring resonator that can be used in the optical transmitter of FIG. 1 according to an embodiment;

[0013] FIG. 3 shows a schematic diagram of an electrical circuit that can be used to operate the ring resonator shown in FIGS. 2A-2B according to an embodiment;

[0014] FIG. 4 shows a flowchart of a tuning method that can be used in the optical transmitter of FIG. 1 according to an embodiment;

[0015] FIG. 5 shows a flowchart of a tuning method that can be used to implement a step of the tuning method of FIG. 4 according to an embodiment;

[0016] FIG. 6 shows a flowchart of a tuning method that can be used to implement another step of the tuning method of FIG. 4 according to an embodiment;

[0017] FIG. 7 graphically illustrates an example response of a ring resonator used in the optical transmitter of FIG. 1 according to an embodiment;

[0018] FIG. 8 shows a flowchart of a tuning method that can be used to implement yet another step of the tuning method of FIG. 4 according to an embodiment;

[0019] FIG. 9 shows a block diagram of an electrical circuit that can be used in the optical transmitter of FIG. 1 according to an embodiment;

[0020] FIG. 10 shows a block diagram of an electrical circuit that can be used in the optical transmitter of FIG. 1 according to another embodiment; and

[0021] FIG. 11 shows a block diagram of an optical receiver according to an embodiment.

DETAILED DESCRIPTION

[0022] At least some embodiments may benefit from the use of some features disclosed in (i) U.S. Patent Application Publication No. 2014/0003810 and (ii) the article by Argishti Melikyan, Kwangwok Kim, Young-Kai Chen, and Po Dong, "Tapless locking of silicon ring modulators for WDM applications," published in the proceedings of 2017 Optical Fiber Communications Conference and Exhibition (OFC), both of which are incorporated herein by reference in their entirety.

[0023] Various embodiments can be used in optical transmitters and/or optical receivers, e.g., as described in more detail below.

[0024] FIG. 1 shows a block diagram of an optical transmitter 100 according to an embodiment. Transmitter 100 can be operated as a wavelength-division-multiplexing (WDM) transmitter. For example, an optical output signal 192 generated by transmitter 100 can have N wavelength components, each having a different one of carrier wavelengths $\lambda_1, \lambda_2, \dots, \lambda_N$ and modulated with a different one of data streams D_1, D_2, \dots, D_N , where N is a positive integer greater than one.

[0025] In an example embodiment, transmitter 100 comprises a light source 110 that includes lasers 112₁-112_N, each configured to generate a respective one of the carrier wavelengths $\lambda_1, \lambda_2, \dots, \lambda_N$. An optical multiplexer (MUX) 120 connected to the lasers 112₁-112_N as indicated in FIG. 1 operates to multiplex the carrier wavelengths and apply a resulting WDM signal 122 to an optical bus 130. In some embodiments, optical bus 130 can be implemented as an on-chip waveguide.

[0026] Transmitter 100 further comprises ring resonators 140₁-140_N, each coupled to optical bus 130 using a suitable optical coupler. An example embodiment of ring resonator 140 is described in more detail below in reference to FIGS. 2A-2B. A person of ordinary skill in the art will understand that, in alternative embodiments, ring resonators 140 having other suitable physical structures may also be used.

[0027] In operation, each of ring resonators 140₁-140_N functions as an optical modulator configured to modulate a respective one of the carrier wavelengths $\lambda_1, \lambda_2, \dots, \lambda_N$ in

response to a respective one of data streams D_1, D_2, \dots, D_N . More specifically, drive circuits 150₁-150_N use data streams D_1, D_2, \dots, D_N , respectively, to appropriately drive ring resonators 140₁-140_N. The modulated carrier wavelengths generated in this manner by ring resonators 140₁-140_N provide the WDM components for optical output signal 192. An example embodiment of drive circuit 150 is described in more detail below in reference to FIG. 3. A person of ordinary skill in the art will understand that, in alternative embodiments, other suitable drive circuits 150 may also be used.

[0028] Transmitter 100 further comprises: (i) a photodetector (e.g., a photodiode, PD) 180; (ii) an electrical-signal conditioner 170; and (iii) an electronic controller 160.

[0029] Photodetector 180 is optically coupled to optical bus 130 by way of an optical tap 190. As a result, photodetector 180 can receive a small portion (e.g., <10%) of the optical power of optical output signal 192 and convert the received light into a corresponding electrical output signal 182.

[0030] Electrical-signal conditioner (e.g., circuit or device) 170 includes electrical circuits that operate to appropriately process, condition, and/or transform electrical signal 182 into a form that is more suitable for the signal processing implemented in electronic controller 160.

[0031] In some embodiments, circuit 170 may include some or all of the following: (i) a transimpedance amplifier; (ii) a frequency filter; (iii) a rectifier; (iv) a radio-frequency (RF) power meter or monitor; and (v) an analog-to-digital converter (ADC). The output signal generated by circuit 170 is an electrical signal 172 that is applied to electronic controller 160. Depending on the embodiment, electrical signal 172 can be an analog signal or a digital signal.

[0032] In some embodiments, circuit 170 can be omitted or integrated into electronic controller 160.

[0033] Electronic controller 160 operates to appropriately tune ring resonators 140₁-140_N. In particular, controller 160 can be used to: (i) register each of ring resonators 140₁-140_N with an intended one of carrier wavelengths $\lambda_1, \lambda_2, \dots, \lambda_N$; (ii) properly spectrally align the optical resonances of ring resonators 140₁-140_N with the respective carrier wavelengths to which the ring resonators are registered; and (iii) lock the spectral alignment to counter any possible detuning that might take place during operation of transmitter 100. These and other pertinent functions of controller 160 can be implemented, e.g., as described in more detail below, using: (i) the electrical inputs to the controller that may include, inter alia, electrical signal 172 (or 182) and a plurality of voltages $V_{pc,n}$ (not explicitly shown in FIG. 1; see FIG. 3) and (ii) the electrical outputs of the controller that may include, inter alia, a control signal 108 and a plurality of electrical signals 162₁-162_N.

[0034] Control signal 108 is applied to light source 110 to imprint wavelength-identifier signals onto the carrier wavelengths $\lambda_1, \lambda_2, \dots, \lambda_N$ generated by lasers 112₁-112_N. In an example embodiment, a wavelength-identifier signal can be a relatively shallow (e.g., ~10% or less) amplitude modulation of the corresponding carrier wavelength. Different wavelength-identifier signals typically have different respective frequencies, e.g., in the kHz range of the RF spectrum, that enable unambiguous identification of the different carrier wavelengths by detecting those frequencies in the corresponding electrical or optical signals downstream from light source 110. An example of such detection is described

in more detail below in reference to FIG. 3. The wavelength-identifier signals can be used, e.g., to register each of ring resonators 140_1 - 140_N with an intended one of carrier wavelengths $\lambda_1, \lambda_2, \dots, \lambda_N$, e.g., as described in more detail below in reference to FIG. 5.

[0035] In one example embodiment, a wavelength-identifier signal can be imprinted onto a carrier wavelength by modulating, with the corresponding frequency, the injection current of the corresponding laser **112**. In another example embodiment, a wavelength-identifier signal can be imprinted onto a carrier wavelength by using an optical modulator (not explicitly shown in FIG. 1), e.g., coupled between the corresponding laser **112** and MUX **120**. A person of ordinary skill in the art will understand that other methods and apparatus for imprinting wavelength-identifier signals onto the carrier wavelengths $\lambda_1, \lambda_2, \dots, \lambda_N$ can also be used.

[0036] In an alternative embodiment, a wavelength-identifier signal can be a relatively slight frequency modulation (e.g., chirp) of the corresponding carrier wavelength. Due to the resonant characteristics of ring resonators 140_1 - 140_N , such chirp can modulate the electrical current flowing through the resonator structure and, as such, is detectable in a manner similar to that described below in reference to FIG. 3.

[0037] Electrical signals 162_1 - 162_N are applied to heaters 166_1 - 166_N , respectively. A heater 166_n may be a part of ring resonator 140_n and/or be located near the loop (e.g., circular) waveguide thereof, where $n=1, 2, \dots, N$. In an example embodiment, heater 166_n can be positioned as indicated in FIG. 2A. In operation, electrical signal 162_n can be used to change the local temperature of ring resonator 140_n , which can change the resonant frequency of the ring resonator through the thermo-optic effect.

[0038] In an example embodiment, controller **160** can be configured to generate electrical signal 162_n in accordance with Eq. (1):

$$V_n = V_{0,n} + V_{1,n} \sin(2\pi f_n t) \quad (1)$$

where V_n is the total voltage of electrical signal 162_n ; $V_{0,n}$ is the quasi-dc component of electrical signal 162_n ; $V_{1,n}$ is the amplitude of the ac component of electrical signal 162_n ; f_n is the oscillation frequency of electrical signal 162_n ; and t is time. The oscillation frequencies f_n are typically different for different n and can be, e.g., in the kHz range. The oscillation frequencies f_n may also be different from the frequencies of the wavelength-identifier signals. The voltage $V_{0,n}$ can be slowly adjusted by controller **160**, e.g., as described in more detail below in reference to FIGS. 6 and 8. As used herein, the term “slowly” means that the characteristic time with which the voltage $V_{0,n}$ is changed is significantly larger than the oscillation period corresponding to any of the oscillation frequencies f_n . The voltage $V_{1,n}$ is typically a constant that may or may not depend on n .

[0039] FIGS. 2A-2B show schematic diagrams of ring resonator 140_n according to an embodiment. More specifically, FIG. 2A shows a top view of ring resonator 140_n , FIG. 2B shows a cross-sectional side view of ring resonator 140_n along the planar cross-section BB indicated in FIG. 2A.

[0040] The ring resonator 140_n shown in FIGS. 2A-2B can be implemented using CMOS-compatible processes and materials. For example, ring resonator 140_n of FIGS. 2A-2B can be fabricated using a silicon-on-insulator (SOI) substrate **202** and includes a circular waveguide (microring) **210**

optically coupled to the optical bus waveguide **130** as indicated in FIG. 2A. Waveguides **210** and **130** can be formed, e.g., by properly etching down the top silicon layer supported on a silicon-oxide layer **206** of SOI substrate **202** (see FIG. 2B). A silicon-oxide cladding layer (not explicitly shown in FIG. 2B) can then be deposited over the structure shown in FIG. 2B to encapsulate the resulting ridge-waveguide core.

[0041] As shown, circular waveguide **210** is a ridge waveguide that has a portion **212** made of n-doped silicon and a portion **214** made of p-doped silicon, the two portions forming a PN junction **212/214** as indicated in FIG. 2B. The location of the PN junction **212/214** may be offset from the center of waveguide **210**. In the shown embodiment, the PN junction **212/214** takes up approximately one-half of the microring circumference. In alternative embodiments, the corresponding PN junction may take up more or less than one-half of the microring circumference.

[0042] Ohmic contacts between the PN junction **212/214** and electrical terminals **252** and **254** are implemented by varying the dopant concentration within a silicon layer **204** that is adjacent to circular waveguide **210**. More specifically, an n+-doped portion **222** and an n++-doped portion **232** of layer **204** are used to provide an ohmic contact between portion **212** of waveguide **210** and electrical terminal **254**. A p+-doped portion **224** and a p++-doped portion **234** of layer **204** are similarly used to provide an ohmic contact between portion **214** of waveguide **210** and electrical terminal **252**. Intermediately doped portions **222** and **224** are optional and may not be present in some embodiments.

[0043] In an example embodiment, a thin-film heater 166_n can be formed near circular waveguide **210**, e.g., as indicated in FIG. 2A. For example, thin-film heater 166_n can be implemented using a titanium microstrip **240** that is vertically separated from circular waveguide **210** by a layer of silicon oxide (not explicitly shown in FIGS. 2A-2B). Electrical terminals **238** and **242** can then be used to apply electrical signal 162_n (e.g., V_n , Eq. (1)) to thin-film heater **240**.

[0044] In operation, the PN junction **212/214** functions as a phase shifter. For example, when a reverse bias is applied to the PN junction **212/214**, a depletion region forms within waveguide **210**. During the positive swing of the drive voltage V_D applied between electrical terminals **252** and **254**, the size of this depletion region increases, thereby decreasing the effective refractive index of waveguide **210**. During the negative swing of the drive voltage V_D , the size of this depletion region decreases, thereby increasing the effective refractive index of waveguide **210**. This modulation of the effective refractive index modulates the resonant frequency of the microring accordingly, which changes the transmittance of the optical bus waveguide **130** at the corresponding carrier wavelength, thereby modulating the intensity thereof and generating the corresponding data-modulated component of optical WDM signal **192** (also see FIG. 1).

[0045] In some embodiments, circular waveguide **210** can be replaced by a suitable closed-loop waveguide that is not necessarily circular in shape. In different embodiments, such a loop waveguide can be selected from a rather broad range of suitable shapes. Such suitable loop shapes typically do not have sharp corners and/or other features that can cause relatively high optical losses.

[0046] As used herein, the term “ring resonator” should be construed to be inclusive of optical resonators having closed-loop waveguides of different suitable loop shapes. As such, the word “ring” should not be construed to unduly limit the covered embodiments to only those having circular waveguides therein.

[0047] In some embodiments, thin-film heater 166_n and/or the corresponding portion of circular waveguide 210 can be replaced by a phase shifter that can control a phase shift of the light traveling therethrough using a mechanism that is different from the thermo-optic effect.

[0048] A variety of phase shifters that can be used for this purpose are known to those skilled in the pertinent art. In an example embodiment, such a phase shifter can be controlled using an electrical signal 162_n that can be described by Eq. (1), either quantitatively or approximately.

[0049] A person of ordinary skill in the art will understand that, together, thin-film heater 166_n and the corresponding portion of circular waveguide 210 form a phase shifter configured to operate based on the thermo-optic effect.

[0050] FIG. 3 shows a schematic diagram of an electrical circuit 300 that can be used to operate ring resonator 140_n according to an embodiment. Circuit 300 comprises a voltage generator 310 that is connected to electrical terminal 254 (also see FIG. 2A) of ring resonator 140_n , through a bias-T formed by the capacitor C and resistors $R1$ and $R2$. In an example embodiment, voltage generator 310 operates to apply a reverse bias to the PN junction $212/214$ of ring resonator 140_n .

[0051] As used herein, the term “reverse bias” refers to an electrical configuration of a semiconductor-junction diode in which the N-type material is at a high electrical potential, and the P-type material is at a low electrical potential. The reverse bias typically causes the depletion layer to grow wider due to a lack of electrons and/or holes, which presents a high impedance path across the junction and substantially prevents a current flow therethrough. However, a very small reverse leakage current can still flow through the junction.

[0052] Similarly, the term “forward bias” refers to an electrical configuration of a semiconductor-junction diode in which the N-type material is at a low potential, and the P-type material is at a high potential. If the forward bias is greater than the intrinsic voltage drop across the corresponding PN or PIN junction, then the corresponding potential barrier can be overcome by the electrical carriers, and a relatively large forward current can flow through the junction.

[0053] The data stream D_n (which can be carried, e.g., by a corresponding electrical NRZ signal) can be applied to the capacitor C as indicated in FIG. 3 (also see FIG. 1).

[0054] Under the reverse-bias conditions, the PN junction $212/214$ is typically capable of generating a photocurrent in response to the light traveling through circular waveguide 210 . In at least some embodiments, the PN junction $212/214$ can generate such photocurrent, e.g., by way of two-photon absorption (TPA). At least a portion I_{pc} of the generated photocurrent flows through the resistors $R1$ and $R2$, which can be converted into the corresponding voltage $V_{pc,n}$ as indicated in FIG. 3. The voltage $V_{pc,n}$ can be provided to electronic controller 160 , where it can be used to determine the voltage $V_{o,n}$ for electrical signal 162_n , e.g., as described below in reference to FIG. 5.

[0055] FIG. 4 shows a flowchart of a tuning method 400 that can be used in optical transmitter 100 according to an embodiment.

[0056] At step 402 of method 400 , each of ring resonators 140_1-140_N can be tuned to register the ring resonator with the intended one of carrier wavelengths $\lambda_1, \lambda_2, \dots, \lambda_N$. Step 402 can be referred to as “coarse tuning,” e.g., because, any ring resonator 140_n can initially be detuned from the intended carrier wavelength by a relatively large $\Delta\lambda$, e.g., such that the intended carrier wavelength is spectrally located outside of the resonator’s frequency band (resonance; also see FIG. 7). The tuning performed at step 402 is therefore directed at tuning ring resonator 140_n such that the optical resonance thereof is spectrally moved closer to the intended carrier wavelength, e.g., in a manner that causes electrical signal 172 (see FIG. 1) to become sensitive to the spectral position of optical resonance relative to the intended carrier wavelength.

[0057] In an example embodiment, controller 160 can be configured to perform step 402 using control signal 108 , voltages $V_{pc,n}$, and electrical signals 162_n , e.g., as described in more detail below in reference to FIG. 5. Upon completion of step 402 , ring resonators 140_1-140_N are typically tuned such that electrical signal 172 (FIG. 1) is sensitive to the relative spectral positions of the intended carrier wavelengths and the optical resonances of the corresponding ring resonators 140_n .

[0058] At step 404 , each of ring resonators 140_1-140_N is further tuned to spectrally align a selected feature of the optical resonances with the respective carrier wavelengths. In various embodiments, such a feature can be, e.g., the center frequency of the optical resonance, an edge of the optical resonance, etc.

[0059] In an example embodiment, controller 160 can be configured to perform step 404 using electrical signals 172 and 162_n , e.g., as described in more detail below in reference to FIG. 6. Upon completion of step 404 , ring resonators 140_1-140_N may be nearly optimally tuned for data transmission under the thermal profile existing across the ring resonators at that time.

[0060] At step 406 , each of ring resonators 140_1-140_N may be continuously tuned to counter any detuning that might occur during operation. Such continuous tuning can be directed, e.g., at approximately maintaining the operating point(s) to which ring resonators 140_1-140_N were tuned upon the completion of step 404 . In an example embodiment, controller 160 can be configured to perform step 406 using electrical signals 172 and 162_n , e.g., as described in more detail below in reference to FIG. 8.

[0061] FIG. 5 shows a flowchart of an example tuning method 500 that can be used to implement step 402 of method 400 according to an embodiment.

[0062] At step 502 of method 500 , controller 160 operates to generate control signal 108 (also see FIG. 1) in a manner that causes light source 110 to imprint different wavelength-identifier signals onto the carrier wavelengths $\lambda_1, \lambda_2, \dots, \lambda_N$. For example, an n -th wavelength-identifier signal imprinted onto the carrier wavelengths λ_n may have a respective modulation frequency F_n that is different from the modulation frequency of any other wavelength-identifier signal. As indicated above, the modulation frequency F_n can modulate the intensity the carrier wavelength λ_n or impose a periodic chirp on the carrier wavelength λ_n .

[0063] Method 500 further includes a processing loop comprising steps 506-512 that can be repeated multiple times to tune different ones of ring resonators 140₁-140_N. Although this processing loop is shown and described as being executed sequentially for different values of n, embodiments of method 500 are not so limited. A person of ordinary skill in the art will understand that controller 160 may alternatively be configured to execute several such processing loops in parallel, with different concurrently executed instances of the processing loop tuning different ones of ring resonators 140₁-140_N.

[0064] Step 504 is the loop initialization step at which ring resonator 140₁ is selected for tuning by setting the value of n to n=1. A person of ordinary skill in the art will understand that, in alternative embodiments, different ones of ring resonators 140₁-140_N may be selected for tuning in any suitable order and not necessarily one at a time.

[0065] At step 506, controller 160 processes the voltage V_{pc,n} (see FIG. 3) to determine whether or not this voltage is modulated with the frequency F_n. Such processing may include subjecting the corresponding signal to frequency decomposition/analysis in a conventional manner, e.g., using a circuit comprising one or more of the following: a frequency filter, a frequency mixer, a spectrum analyzer, and a Fourier-transform circuit. If the frequency F_n is not detected in the voltage V_{pc,n}, then the processing of method 500 is directed to step 508. Otherwise, the processing of method 500 is directed to step 510.

[0066] At step 508, controller 160 changes the voltage V_{o,n} used in electrical signal 162_n, (see Eq. (1)). The change causes the local temperature of ring resonator 140_n to change, which produces a corresponding spectral shift of the optical resonance of ring resonator 140_n due to the thermo-optic effect. The processing of method 500 is then directed back to step 506.

[0067] At step 510, a next ring resonator 140_n is selected for being tuned, by incrementing the value of n by one.

[0068] Step 512 serves to determine whether or not all of the ring resonators 140₁-140_N are registered with the corresponding carrier wavelengths. If yes, then method 500 is terminated, and the subsequent processing can typically be directed to step 404 of method 400 (FIG. 4). Otherwise, the processing of method 500 is directed back to step 506.

[0069] FIG. 6 shows a flowchart of an example tuning method 600 that can be used to implement step 404 of method 400 according to an embodiment. More specifically, method 600 is directed at tuning ring resonators 140₁-140_N such that each of carrier wavelengths λ₁, λ₂, . . . , λ_N becomes spectrally aligned with a selected edge of the optical resonance of the corresponding ring resonator, e.g., as graphically indicated in FIG. 7.

[0070] At step 602 of method 600, controller 160 operates to generate electrical signals 162₁-162_N in accordance with Eq. (1) using the voltages V_{o,n} (n=1, 2, . . . , N) determined at step 402 of method 400 (also see FIGS. 4-5).

[0071] FIG. 7 graphically illustrates an example response of ring resonator 140_n to electrical signal 162_n, e.g., generated at step 602 of method 600. Herein, the carrier wavelength λ_n is located within the optical resonance of ring resonator 140_n, represented by curves 702, 704, and 706. More specifically, the time dependence (dithering) of electrical signal 162_n (also see Eq. (1)) causes the optical resonance of ring resonator 140_n to oscillate between the spectral positions indicated by curves 704 and 706. Curve

702 indicates the spectral position of the optical resonance of ring resonator 140_n when the dithering is turned OFF (e.g., by setting the dither amplitude V_{1,n} to zero; also see Eq. (1)).

[0072] Curve 710 shown in the inset of FIG. 7 illustrates the intensity modulation of the carrier wavelength λ_n caused by the oscillation of the optical resonance of ring resonator 140_n between the spectral positions 704 and 706. For example, when the optical resonance is at position 704, the transmission of ring resonator 140_n at the carrier wavelength λ_n is relatively low, which causes the corresponding WDM component of optical output signal 192 to have a relatively low intensity I₁. When the optical resonance is at position 706, the transmission of ring resonator 140_n at the carrier wavelength λ_n is relatively high, which causes the corresponding WDM component of optical output signal 192 to have a relatively high intensity I₂. The oscillation of the optical resonance between positions 704 and 706 thus causes the intensity of the corresponding WDM component of optical output signal 192 to oscillate between the intensities I₁ and I₂ with the frequency f_n, as indicated by curve 710.

[0073] Due to the dither-induced intensity modulation of carrier wavelengths λ₁, λ₂, . . . , λ_N with frequencies f₁, f₂, . . . , f_N, respectively, electrical signal 172 (see FIG. 1) typically contains multiple corresponding frequency tones. The amplitudes of these frequency tones can be measured, e.g., as known in the pertinent art, by subjecting electrical signal 172 to frequency decomposition/analysis. Example circuits that can be used in controller 160 for this purpose are described in more detail below in reference to FIGS. 9-10.

[0074] Referring back to FIG. 6, method 600 has a processing loop comprising steps 606-614 that can be run multiple times to tune different ones of ring resonators 140₁-140_N. Although this processing loop is shown and described as being executed sequentially for different values of n, embodiments of method 600 are not so limited. A person of ordinary skill in the art will understand that controller 160 may alternatively be configured to execute several such processing loops in parallel, with different concurrently executed instances of the processing loop being configured to tune different ones of ring resonators 140₁-140_N. Step 604 is the loop initialization step at which ring resonator 140₁ is selected for tuning by setting the loop-index value n to n=1. A person of ordinary skill in the art will understand that, in alternative embodiments, different ones of ring resonators 140₁-140_N may be selected for tuning in any suitable order and not necessarily one at a time.

[0075] At step 606, controller 160 processes electrical signal 172 to measure the amplitude of the n-th tone thereof (e.g., the tone having the frequency f_n). In different embodiments, step 606 can be performed in the analog domain or in the digital domain.

[0076] At step 608, controller 160 determines whether or not the amplitude measured at step 606 has an optimal value. If the measured amplitude does not have an optimal value, then the processing of method 600 is directed to step 610. Otherwise, the processing of method 600 is directed to step 612.

[0077] In an example embodiment, an optimal value of the amplitude may be close to the maximum possible amplitude of the n-th tone of electrical signal 172. Said maximum amplitude typically corresponds to the spectral alignment in which the steepest slope of curve 702 is at the carrier wavelength λ_n (also see FIG. 7). This spectral alignment can

be beneficial, e.g., because it facilitates the opening of the eye of optical signal **192** at the carrier wavelength λ_n .

[0078] Step **608** can therefore be implemented using conventional methods for finding an approximate maximum of a signal. For example, thresholding the changes of the tone's amplitude caused by the changes of electrical signal **162_n**, or estimating the derivative of the tone's amplitude with respect to the voltage $V_{o,n}$ (see Eq. (1)) can be used for this purpose. Other suitable methods can also be applied as known in the pertinent art.

[0079] At step **610**, controller **160** changes the voltage $V_{o,n}$ used in electrical signal **162_n**, (see Eq. (1)). The change causes the local temperature of ring resonator **140_n** to change, which produces a corresponding spectral shift of the curves **702-706** due to the thermo-optic effect. The processing of method **600** is then directed back to step **606**.

[0080] At step **612**, a next ring resonator **140_n** is selected for tuning, by incrementing the value of n by one.

[0081] Step **614** serves to determine whether or not all of the ring resonators **140₁-140_N** have been tuned to optimize the optical modulation amplitude. If yes, then method **600** is terminated, and the subsequent processing can typically be directed to step **406** of method **400** (FIG. 4). Otherwise, the processing of method **600** is directed back to step **606**.

[0082] FIG. 8 shows a flowchart of an example tuning method **800** that can be used to implement step **406** of method **400** according to an embodiment. More specifically, method **800** is directed at continuously adjusting the quasi-dc heater voltages $V_{o,n}$ of signals **162₁-162_N** to maintain the spectral alignments obtained at step **404** of method **400**.

[0083] At step **802** of method **800**, controller **160** operates to convert electrical signal **172** into digital form. Step **802** may also include some signal conditioning, performed either before or after the conversion, or both.

[0084] At step **804**, controller **160** operates to apply a Fourier transform to the signal generated at step **802**. The resulting digital spectrum typically contains pronounced spectral components at frequencies f_1, f_2, \dots, f_N due to the presence of the above-described frequency tones in electrical signal **172**. The amplitudes of these spectral components can be measured and stored in the memory for further use, e.g., at step **806**.

[0085] At step **806**, controller **160** uses the amplitudes of the spectral components measured at step **804** as inputs to a locking algorithm configured to determine adjustments (if any are needed) to the voltages $V_{o,n}$, with the adjustments being such that the spectral alignments achieved at step **404** of method **400** can be maintained. As already indicated above, some or all of the voltages $V_{o,n}$ may need to be adjusted, from time to time, to counter possible detuning of ring resonators **140₁-140_N** caused, e.g., by local temperature fluctuations.

[0086] In an example embodiment, the locking algorithm used at step **806** may be configured to keep the amplitudes of the spectral components located at frequencies f_1, f_2, \dots, f_N near their respective maximum values. Many signal-processing algorithms suitable for this purpose are known to persons skilled in the pertinent art. One example of such an algorithm is a least mean squares (LMS) algorithm.

[0087] At step **808**, controller **160** operates to change some or all of heater signals **162₁-162_N** using the adjustments determined at step **806**. The processing of method **800** is then directed back to step **802**.

[0088] FIG. 9 shows a block diagram of an electrical circuit **900** that can be used in controller **160** (FIG. 1) according to an embodiment. Circuit **900** can be used, e.g., to generate heater signals **162₁-162_N** in response to feedback signal **172**. Circuit **900** can also be used to implement method **800**, e.g., as described below.

[0089] Circuits **910** and **920** of circuit **900** can be used to implement step **802** of method **800**. More specifically, circuit **910** comprises an analog-to-digital converter (ADC) that operates in a conventional manner to convert feedback signal **172** into a corresponding stream **912** of digital samples. Circuit **920** may then be used to apply some digital processing to digital stream **912**, thereby converting it to a digital stream **922** that may be better suited for the signal processing implemented in the downstream circuits. In some embodiments, circuit **920** may be absent.

[0090] A fast-Fourier-transform (FFT) module **930** can be used to implement step **804** of method **800**. In operation, FFT module **930** applies Fourier transformation to digital stream **922**, thereby converting it into a corresponding set of spectral samples. FFT module **930** may then filter and/or post-process the generated spectral samples to determine or estimate the amplitudes $A(f_1), A(f_2), \dots, A(f_N)$ of the frequency tones located at frequencies f_1, f_2, \dots, f_N . The amplitudes $A(f_1), A(f_2), \dots, A(f_N)$ are then outputted for further use in the downstream circuits.

[0091] A locking-algorithm module **930** can be used to implement step **806** of method **800**.

[0092] In operation, module **930** runs, for example, an LMS algorithm to generate control signals **942₁-942_N** in response to the amplitudes $A(f_1), A(f_2), \dots, A(f_N)$ received from FFT module **930**. Module **930** then applies control signals **942₁-942_N** to a voltage generator **950**.

[0093] Voltage generator **950** can be used to implement step **808** of method **800**. In response to control signals **942₁-942_N** received from module **930**, voltage generator **950** generates heater signals **162₁-162_N**, wherein some of the voltages $V_{o,n}$ may have been adjusted to counteract the detuning of the corresponding ones of ring resonators **140₁-140_N**.

[0094] FIG. 10 shows a block diagram of an electrical circuit **1000** that can be used in controller **160** (FIG. 1) according to another embodiment. Circuit **1000** can be used, e.g., to generate heater signals **162₁-162_N** in response to the PD output signal **182**. Circuit **1000** can also be used to implement step **406** of method **400**.

[0095] Circuit **1000** comprises an RF power monitor **1010** capable of monitoring the power of PD output signal **182** within the appropriate bandwidth greater than any of the frequencies f_1, f_2, \dots, f_N . In this embodiment, the electrical output signal **172** generated by power monitor **1010** can be a superposition of RF components at frequencies f_1, f_2, \dots, f_N , each proportional to the optical-modulation amplitude at that frequency.

[0096] Circuit **1000** further comprises an analog frequency analyzer **1020** configured to determine or estimate the amplitudes $A(f_1), A(f_2), \dots, A(f_N)$ of the RF components of signal **172** located at frequencies f_1, f_2, \dots, f_N . In an example embodiment, frequency analyzer **1020** may include a tunable RF source operating as a local oscillator, an RF signal mixer, and one or more frequency filters connected in a conventional manner. A sweep of the tunable RF source through the appropriate frequency range enables selection of the different RF components of signal **172** for amplitude

measurements. The amplitudes $A(f_1)$, $A(f_2)$, . . . , $A(f_N)$ measured in this manner are then applied to a proportional-integral-differential (PID) controller **1030**.

[0097] In response to the amplitudes $A(f_1)$, $A(f_2)$, . . . , $A(f_N)$ received from analog frequency analyzer **1020**, PID controller **1030** generates heater signals **162₁-162_N** such that each of said amplitudes is driven toward or kept near the maximum possible value thereof. The latter can be achieved, e.g., by appropriately adjusting the voltages $V_{0,n}$ to counteract the detuning of the ring resonators **140₁-140_N**.

[0098] FIG. **11** shows a block diagram of an optical receiver **1100** according to an embodiment. Receiver **1100** can be operated as a WDM receiver capable of properly detecting optical output signal **192** generated by WDM transmitter **100** (FIG. **1**). As already indicated above, optical signal **192** may have N wavelength components, each having a different one of carrier wavelengths $\lambda_1, \lambda_2, \dots, \lambda_N$.

[0099] Receiver **1100** comprises ring resonators **1140₁-1140_N**, each coupled to an optical bus **1130** using a suitable optical coupler. Ring resonator **1140_n**, differs from ring resonator **140_n** (FIG. **1**) in that ring resonator **1140_n**, additionally includes a drop waveguide **1142_n** coupled to circular waveguide **210** (see FIG. **2**). Each of drop waveguides **1142₁-1142_N** is configured to feed light into a respective one of photodetectors **1150₁-1150_N**. In operation, ring resonators **1140₁-1140_N** work as demultiplexing filters that distribute different modulated carrier wavelengths to different ones of photodetectors **1150₁-1150_N**.

[0100] Receiver **1100** further comprises an electronic controller **1160** that can tune ring resonators **1140₁-1140_N** using heaters **1166₁-1166_N**, respectively. Said tuning can be performed using: (i) a feedback signal **1172** generated using an optical tap **1190**, a photodetector **1180**, and an optional electrical-signal conditioner (e.g., circuit or device) **1170** and/or (ii) electrical signals **1152₁-1152_N** generated by photodetectors **1150₁-1150_N**. In particular, controller **1160** can be used to: (i) register each of ring resonators **1140₁-1140_N** with an intended one of carrier wavelengths $\lambda_1, \lambda_2, \dots, \lambda_N$; (ii) properly spectrally align the optical resonances of ring resonators **1140₁-1140_N** with the respective carrier wavelengths to which the ring resonators are registered; and (iii) maintain the spectral alignment to counter any possible detuning of ring resonators **1140₁-1140_N** that might take place during operation of receiver **1100**.

[0101] A person of ordinary skill in the art will understand, without any undue experimentation, how to adapt at least some of the above-described methods **400**, **500**, **600**, and **800** for use in receiver **1100**.

[0102] According to an example embodiment disclosed above, e.g., in the summary section and/or in reference to any one or any combination of some or all of FIGS. **1-11**, provided is an apparatus comprising: a plurality of optical ring resonators (e.g., **140₁-140_N**, FIG. **1**) optically coupled to an optical waveguide (e.g., **130**, FIG. **1**) at respective locations along the optical waveguide; a plurality of heaters (e.g., **166₁-166_N**, FIG. **1**), each of the heaters being located at a respective one of the optical ring resonators; a photodetector (e.g., **180**, FIG. **1**) optically coupled to the optical waveguide downstream from the respective locations; and an electronic controller (e.g., **160**, FIG. **1**) being configured to: regulate (e.g., at **404**, **406**, FIG. **4**) the plurality of heaters in response to an electrical output signal generated by the photodetector while electrical drive signals of the heaters are being dithered in amplitude (e.g., in accordance with Eq.

(1)); and dither the electrical drive signals of different ones of the heaters with different respective frequencies.

[0103] In some embodiments of the above apparatus, the electronic controller is further configured to: measure (e.g., at **606**, FIG. **6**; **804**, FIG. **8**) amplitudes of frequency tones of the electrical output signal at the different respective frequencies; and regulate (e.g., at **610**, FIG. **6**; **808**, FIG. **8**) each of the heaters using measured values of a respective one of said amplitudes.

[0104] In some embodiments of any of the above apparatus, the electronic controller comprises a Fourier-transform circuit (e.g., **930**, FIG. **9**) configured to measure amplitudes of frequency tones of the electrical output signal by applying a Fourier transform to digital samples corresponding to the electrical output signal.

[0105] In some embodiments of any of the above apparatus, the electronic controller comprises a frequency analyzer (e.g., **1020**, FIG. **10**) configured to measure amplitudes of frequency tones of the electrical output signal using analog frequency decomposition.

[0106] In some embodiments of any of the above apparatus, the electronic controller comprises a radio-frequency power monitor (e.g., **1010**, FIG. **10**) connected to provide an electrical input to the frequency analyzer in response to the electrical output signal.

[0107] In some embodiments of any of the above apparatus, the electronic controller is configured to regulate a particular one of the heaters based on a measurement of a frequency component of the electrical output signal, the frequency component being of the respective frequency used to dither the electrical drive signal of the particular one of the heaters.

[0108] In some embodiments of any of the above apparatus, the electronic controller is configured to regulate the particular one of the heaters such that the amplitude of the frequency component of the respective frequency remains near a maximum thereof.

[0109] In some embodiments of any of the above apparatus, the apparatus further comprises an optical WDM transmitter (e.g., **100**, FIG. **1**) that includes the plurality of optical ring resonators.

[0110] In some embodiments of any of the above apparatus, the apparatus further comprises an optical WDM receiver (e.g., **1100**, FIG. **11**) that includes the plurality of optical ring resonators.

[0111] In some embodiments of any of the above apparatus, the apparatus further comprises a light source (e.g., **110**, FIG. **1**) configured to transmit a plurality of carrier wavelengths through the optical waveguide.

[0112] In some embodiments of any of the above apparatus, the electronic controller is configured to regulate each of the heaters to spectrally align (e.g., at **402**, **404**, FIG. **4**) a resonance (e.g., **702**, FIG. **7**) of a respective one of the optical ring resonators with a respective carrier wavelength (e.g., λ_n , FIG. **7**) of the plurality of carrier wavelengths.

[0113] In some embodiments of any of the above apparatus, each of the optical ring resonators comprises a respective optical waveguide loop (e.g., **210**, FIG. **2A**) that includes at least a portion of a respective semiconductor diode (e.g., **212/214**, FIG. **2B**) configured to generate a respective photocurrent (e.g., I_{pc} , FIG. **3**) in response to light in said respective optical waveguide loop; and wherein the

electronic controller is further configured to regulate (e.g., at **402**, FIG. **4**) each of the heaters in response to the respective photocurrent.

[0114] According to another example embodiment disclosed above, e.g., in the summary section and/or in reference to any one or any combination of some or all of FIGS. **1-11**, provided is an apparatus comprising: a light source (e.g., **110**, FIG. **1**) configured to transmit a plurality of carrier wavelengths through an optical waveguide, each of the carrier wavelengths being modulated at a different respective frequency (e.g., F_n , FIG. **5**); a plurality of optical ring resonators (e.g., **140₁-140_N**, FIG. **1**) optically coupled to the optical waveguide (e.g., **130**, FIG. **1**) at respective locations along the optical waveguide to receive the plurality of carrier wavelengths, each of the optical ring resonators comprising a respective optical waveguide loop (e.g., **210**, FIG. **2A**) that includes at least a portion of a respective semiconductor diode (e.g., **212/214**, FIG. **2B**) capable of generating a respective photocurrent (e.g., I_{pc} , FIG. **3**) in response to light in said respective optical waveguide loop; a plurality of heaters (e.g., **166₁-166_N**, FIG. **1**), each of the heaters being located to heat a respective one of the optical ring resonators; and an electronic controller (e.g., **160**, FIG. **1**) configured to regulate (e.g., at **402**, FIG. **4**; **508**, FIG. **5**) the plurality of heaters in response to detecting at least some of said respective frequencies in the respective photocurrents.

[0115] In some embodiments of the above apparatus, the electronic controller is further configured to regulate each one of the heaters to about spectrally align (e.g., at **402**, FIG. **4**) a resonance (e.g., **702**, FIG. **7**) of the respective one of the optical ring resonators with a respective one of the carrier wavelengths (e.g., λ_n , FIG. **7**) based on detecting the respective frequency in the respective photocurrent.

[0116] In some embodiments of any of the above apparatus, the apparatus further comprises an optical WDM transmitter (e.g., **100**, FIG. **1**) that includes the plurality of optical ring resonators.

[0117] In some embodiments of any of the above apparatus, the apparatus further comprises an optical WDM receiver (e.g., **1100**, FIG. **11**) that includes the plurality of optical ring resonators.

[0118] In some embodiments of any of the above apparatus, at least some of the respective photocurrents are generated by way of two-photon absorption in the respective optical waveguide loops.

[0119] In some embodiments of any of the above apparatus, the light source is configured to intensity-modulate the carrier wavelengths with the different respective frequencies using a modulation depth of less than about 10%.

[0120] In some embodiments of any of the above apparatus, the light source is configured to chirp the carrier wavelengths with the different respective frequencies.

[0121] According to yet another example embodiment disclosed above, e.g., in the summary section and/or in reference to any one or any combination of some or all of FIGS. **1-11**, provided is an apparatus comprising: a plurality of optical ring resonators (e.g., **140₁-140_N**, FIG. **1**) optically coupled to an optical waveguide (e.g., **130**, FIG. **1**) at respective locations along the optical waveguide; a plurality of phase shifters (e.g., **210/166_n**, FIG. **2**), each of the phase shifters being in a respective one of the optical ring resonators; a photodetector (e.g., **180**, FIG. **1**) optically coupled to the optical waveguide downstream from the respective

locations; and an electronic controller (e.g., **160**, FIG. **1**) being configured to: regulate (e.g., at **404**, **406**, FIG. **4**) the plurality of phase shifters in response to an electrical output signal generated by the photodetector while electrical drive signals of the phase shifters are being dithered in amplitude (e.g., in accordance with Eq. (1)); and dither the electrical drive signals of different ones of the phase shifters with different respective frequencies.

[0122] While this disclosure includes references to illustrative embodiments, this specification is not intended to be construed in a limiting sense. Various modifications of the described embodiments, as well as other embodiments within the scope of the disclosure, which are apparent to persons skilled in the art to which the disclosure pertains are deemed to lie within the principle and scope of the disclosure, e.g., as expressed in the following claims.

[0123] Unless explicitly stated otherwise, each numerical value and range should be interpreted as being approximate as if the word “about” or “approximately” preceded the value or range.

[0124] It will be further understood that various changes in the details, materials, and arrangements of the parts which have been described and illustrated in order to explain the nature of this disclosure may be made by those skilled in the art without departing from the scope of the disclosure, e.g., as expressed in the following claims.

[0125] The use of figure numbers and/or figure reference labels in the claims is intended to identify one or more possible embodiments of the claimed subject matter in order to facilitate the interpretation of the claims. Such use is not to be construed as necessarily limiting the scope of those claims to the embodiments shown in the corresponding figures.

[0126] Although the elements in the following method claims, if any, are recited in a particular sequence with corresponding labeling, unless the claim recitations otherwise imply a particular sequence for implementing some or all of those elements, those elements are not necessarily intended to be limited to being implemented in that particular sequence.

[0127] Reference herein to “one embodiment” or “an embodiment” means that a particular feature, structure, or characteristic described in connection with the embodiment can be included in at least one embodiment of the disclosure. The appearances of the phrase “in one embodiment” in various places in the specification are not necessarily all referring to the same embodiment, nor are separate or alternative embodiments necessarily mutually exclusive of other embodiments. The same applies to the term “implementation.”

[0128] Unless otherwise specified herein, the use of the ordinal adjectives “first,” “second,” “third,” etc., to refer to an object of a plurality of like objects merely indicates that different instances of such like objects are being referred to, and is not intended to imply that the like objects so referred-to have to be in a corresponding order or sequence, either temporally, spatially, in ranking, or in any other manner.

[0129] Throughout the detailed description, the drawings, which are not to scale, are illustrative only and are used in order to explain, rather than limit the disclosure. The use of terms such as height, length, width, top, bottom, is strictly to facilitate the description of the embodiments and is not intended to limit the embodiments to a specific orientation. For example, height does not imply only a vertical rise

limitation, but is used to identify one of the three dimensions of a three dimensional structure as shown in the figures. Such “height” would be vertical where the electrodes are horizontal but would be horizontal where the electrodes are vertical, and so on.

[0130] Also for purposes of this description, the terms “couple,” “coupling,” “coupled,” “connect,” “connecting,” or “connected” refer to any manner known in the art or later developed in which energy is allowed to be transferred between two or more elements, and the interposition of one or more additional elements is contemplated, although not required. Conversely, the terms “directly coupled,” “directly connected,” etc., imply the absence of such additional elements. The same type of distinction applies to the use of terms “attached” and “directly attached,” as applied to a description of a physical structure. For example, a relatively thin layer of adhesive or other suitable binder can be used to implement such “direct attachment” of the two corresponding components in such physical structure.

[0131] The described embodiments are to be considered in all respects as only illustrative and not restrictive. In particular, the scope of the disclosure is indicated by the appended claims rather than by the description and figures herein. All changes that come within the meaning and range of equivalency of the claims are to be embraced within their scope.

[0132] The functions of the various elements shown in the figures, including any functional blocks labeled as “processors” and/or “controllers,” may be provided through the use of dedicated hardware as well as hardware capable of executing software in association with appropriate software. When provided by a processor, the functions may be provided by a single dedicated processor, by a single shared processor, or by a plurality of individual processors, some of which may be shared. Moreover, explicit use of the term “processor” or “controller” should not be construed to refer exclusively to hardware capable of executing software, and may implicitly include, without limitation, digital signal processor (DSP) hardware, network processor, application specific integrated circuit (ASIC), field programmable gate array (FPGA), read only memory (ROM) for storing software, random access memory (RAM), and non volatile storage. Other hardware, conventional and/or custom, may also be included. Similarly, any switches shown in the figures are conceptual only. Their function may be carried out through the operation of program logic, through dedicated logic, through the interaction of program control and dedicated logic, or even manually, the particular technique being selectable by the implementer as more specifically understood from the context.

[0133] As used in this application, the term “circuitry” may refer to one or more or all of the following: (a) hardware-only circuit implementations (such as implementations in only analog and/or digital circuitry); (b) combinations of hardware circuits and software, such as (as applicable): (i) a combination of analog and/or digital hardware circuit(s) with software/firmware and (ii) any portions of hardware processor(s) with software (including digital signal processor(s)), software, and memory(ies) that work together to cause an apparatus, such as a mobile phone or server, to perform various functions); and (c) hardware circuit(s) and or processor(s), such as a microprocessor(s) or a portion of a microprocessor(s), that requires software (e.g., firmware) for operation, but the software may not be present

when it is not needed for operation.” This definition of circuitry applies to all uses of this term in this application, including in any claims. As a further example, as used in this application, the term circuitry also covers an implementation of merely a hardware circuit or processor (or multiple processors) or portion of a hardware circuit or processor and its (or their) accompanying software and/or firmware. The term circuitry also covers, for example and if applicable to the particular claim element, a baseband integrated circuit or processor integrated circuit for a mobile device or a similar integrated circuit in server, a cellular network device, or other computing or network device.

[0134] It should be appreciated by those of ordinary skill in the art that any block diagrams herein represent conceptual views of illustrative circuitry embodying the principles of the disclosure. Similarly, it will be appreciated that any flow charts, flow diagrams, state transition diagrams, pseudo code, and the like represent various processes which may be substantially represented in computer readable medium and so executed by a computer or processor, whether or not such computer or processor is explicitly shown.

[0135] As used herein and in the claims, the term “provide” with respect to a system, device, or component encompasses designing or fabricating the system, device, or component; causing the system, device, or component to be designed or fabricated; and/or obtaining the system, device, or component by purchase, lease, rental, or other contractual arrangement.

What is claimed is:

1. An apparatus comprising:
 - a plurality of optical ring resonators optically coupled to an optical waveguide at respective locations along the optical waveguide;
 - a plurality of heaters, each of the heaters being located at a respective one of the optical ring resonators;
 - a photodetector optically coupled to the optical waveguide downstream from the respective locations; and
 - an electronic controller being configured to:
 - regulate the plurality of heaters in response to an electrical output signal generated by the photodetector while electrical drive signals of the heaters are being dithered in amplitude; and
 - dither the electrical drive signals of different ones of the heaters with different respective frequencies.
2. The apparatus of claim 1, wherein the electronic controller is further configured to:
 - measure amplitudes of frequency tones of the electrical output signal at the different respective frequencies; and
 - regulate each of the heaters using measured values of a respective one of said amplitudes.
3. The apparatus of claim 1, wherein the electronic controller comprises a Fourier-transform circuit configured to measure amplitudes of frequency tones of the electrical output signal by applying a Fourier transform to digital samples corresponding to the electrical output signal.
4. The apparatus of claim 1, wherein the electronic controller comprises a frequency analyzer configured to measure amplitudes of frequency tones of the electrical output signal using analog frequency decomposition.
5. The apparatus of claim 4, wherein the electronic controller comprises a radio-frequency power monitor connected to provide an electrical input to the frequency analyzer in response to the electrical output signal.

6. The apparatus of claim 1, wherein the electronic controller is configured to regulate a particular one of the heaters based on a measurement of a frequency component of the electrical output signal, the frequency component being of the respective frequency used to dither the electrical drive signal of the particular one of the heaters.

7. The apparatus of claim 6, wherein the electronic controller is configured to regulate the particular one of the heaters such that an amplitude of the frequency component of the respective frequency remains near a maximum thereof.

8. The apparatus of claim 1, further comprising an optical WDM transmitter that includes the plurality of optical ring resonators.

9. The apparatus of claim 1, further comprising an optical WDM receiver that includes the plurality of optical ring resonators.

10. The apparatus of claim 1, further comprising a light source configured to transmit a plurality of carrier wavelengths through the optical waveguide.

11. The apparatus of claim 10, wherein the electronic controller is configured to regulate each of the heaters to spectrally align a resonance of a respective one of the optical ring resonators with a respective carrier wavelength of the plurality of carrier wavelengths.

12. The apparatus of claim 1,

wherein each of the optical ring resonators comprises a respective optical waveguide loop that includes at least a portion of a respective semiconductor diode configured to generate a respective photocurrent in response to light in said respective optical waveguide loop; and wherein the electronic controller is further configured to regulate each of the heaters in response to the respective photocurrent.

13. An apparatus comprising:

a light source configured to transmit a plurality of carrier wavelengths through an optical waveguide, each of the carrier wavelengths being modulated at a different respective frequency;

a plurality of optical ring resonators optically coupled to the optical waveguide at respective locations along the optical waveguide to receive the plurality of carrier wavelengths, each of the optical ring resonators comprising a respective optical waveguide loop that includes at least a portion of a respective semiconduc-

tor diode capable of generating a respective photocurrent in response to light in said respective optical waveguide loop;

a plurality of heaters, each of the heaters being located to heat a respective one of the optical ring resonators; and an electronic controller configured to regulate the plurality of heaters in response to detecting at least some of said respective frequencies in the respective photocurrents.

14. The apparatus of claim 13, wherein the electronic controller is further configured to regulate each one of the heaters to about spectrally align a resonance of the respective one of the optical ring resonators with a respective one of the carrier wavelengths based on detecting the respective frequency in the respective photocurrent.

15. The apparatus of claim 13, further comprising an optical WDM transmitter that includes the plurality of optical ring resonators.

16. The apparatus of claim 13, further comprising an optical WDM receiver that includes the plurality of optical ring resonators.

17. The apparatus of claim 13, wherein at least some of the respective photocurrents are generated by way of two-photon absorption in the respective optical waveguide loops.

18. The apparatus of claim 13, wherein the light source is configured to intensity-modulate the carrier wavelengths with the different respective frequencies using a modulation depth of less than about 10%.

19. The apparatus of claim 13, wherein the light source is configured to chirp the carrier wavelengths with the different respective frequencies.

20. An apparatus comprising:

a plurality of optical ring resonators optically coupled to an optical waveguide at respective locations along the optical waveguide;

a plurality of phase shifters, each of the phase shifters being in a respective one of the optical ring resonators; a photodetector optically coupled to the optical waveguide downstream from the respective locations; and an electronic controller being configured to:

regulate the plurality of phase shifters in response to an electrical output signal generated by the photodetector while electrical drive signals of the phase shifters are being dithered in amplitude; and

dither the electrical drive signals of different ones of the phase shifters with different respective frequencies.

* * * * *