



US 20120042500A1

(19) **United States**

(12) **Patent Application Publication**
Determan et al.

(10) **Pub. No.: US 2012/0042500 A1**

(43) **Pub. Date: Feb. 23, 2012**

(54) **THERMAL EXPANSION COMPENSATOR**

Publication Classification

(75) Inventors: **William Determan**, Sylmar, CA (US); **Daniel Edward Matejczyk**, West Hill, CA (US)

(51) **Int. Cl.**
B23P 17/04 (2006.01)

(73) Assignee: **HAMILTON SUNDSTRAND SPACE SYSTEMS INTERNATIONAL, INC.**, Windsor Locks, CT (US)

(52) **U.S. Cl.** **29/460**

(21) Appl. No.: **13/183,128**

(22) Filed: **Jul. 14, 2011**

(57) **ABSTRACT**

A thermal expansion compensator is provided and includes a first electrode structure having a first surface, a second electrode structure having a second surface facing the first surface and an elastic element bonded to the first and second surfaces and including a conductive element by which the first and second electrode structures electrically and/or thermally communicate, the conductive element having a length that is not substantially longer than a distance between the first and second surfaces.

Related U.S. Application Data

(62) Division of application No. 12/857,965, filed on Aug. 17, 2010.

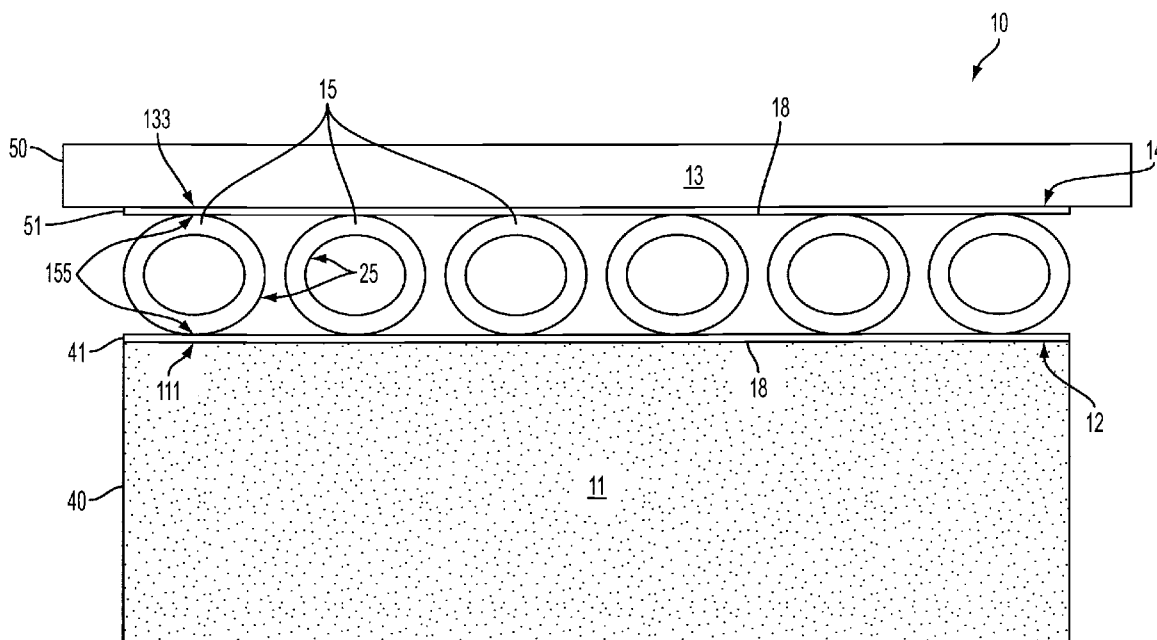

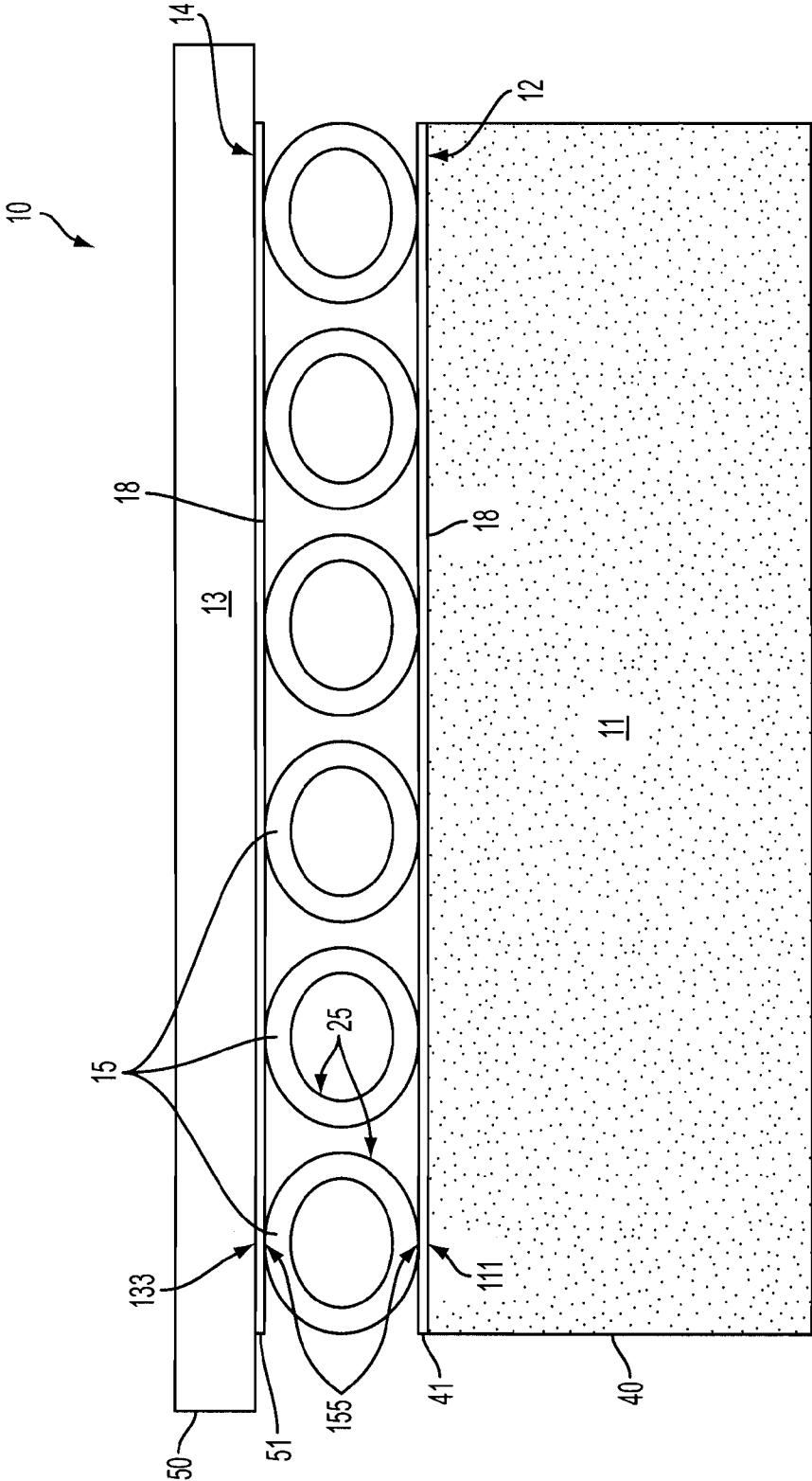

FIG. 1

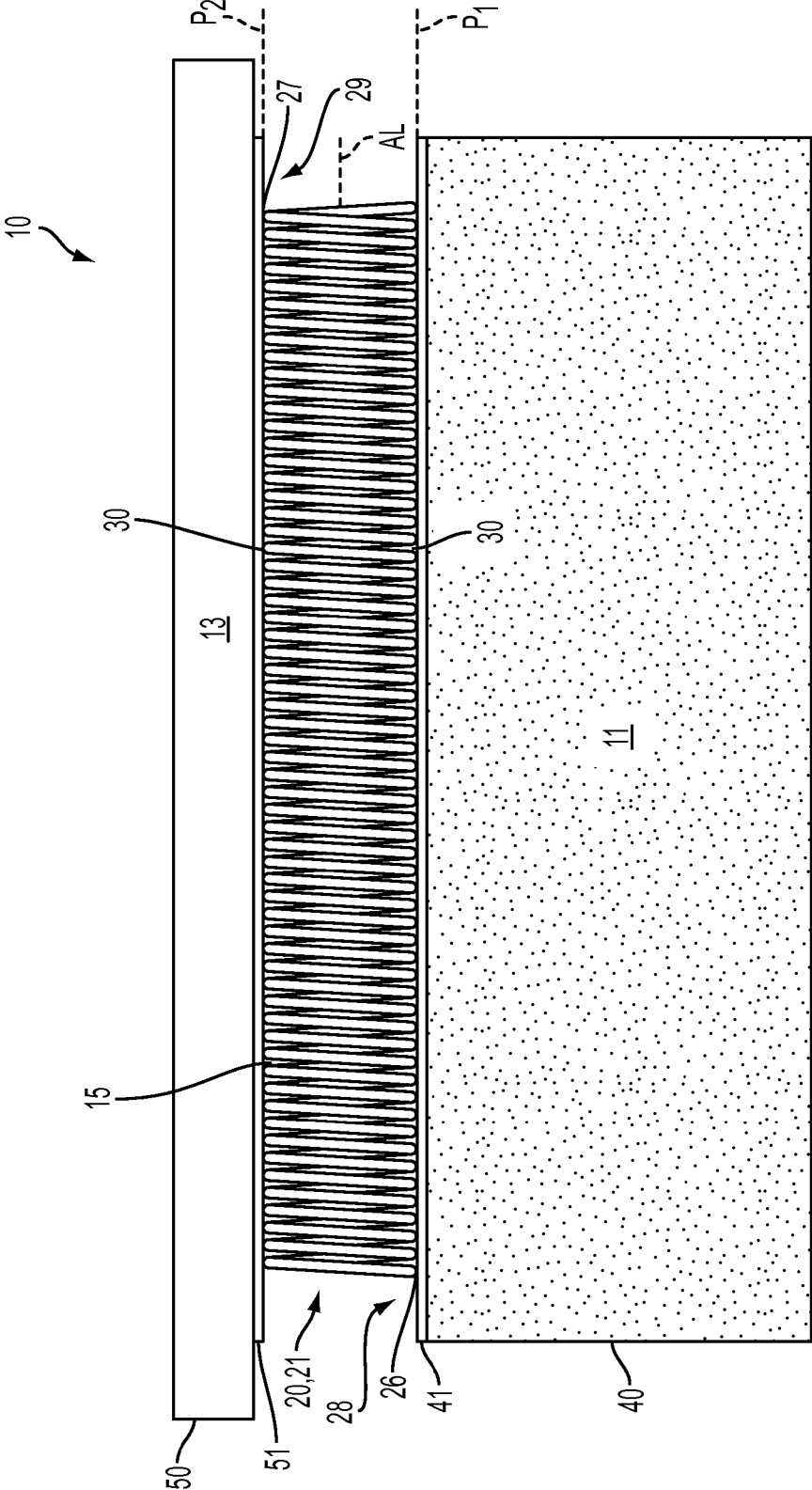

FIG. 2

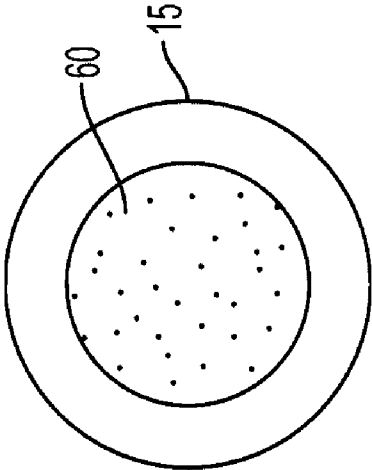

FIG. 3A

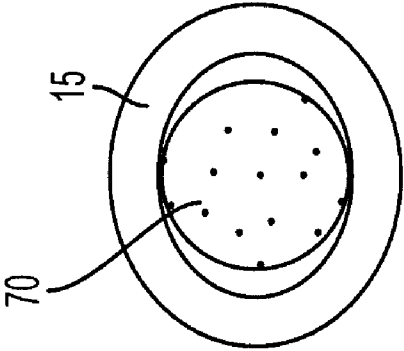

FIG. 3B

THERMAL EXPANSION COMPENSATOR

CROSS-REFERENCE TO RELATED APPLICATION

[0001] The present application is a divisional application of and claims the benefit of priority to application Ser. No. 12/857,965, entitled, "THERMAL EXPANSION COMPENSATOR HAVING AN ELASTIC CONDUCTIVE ELEMENT BONDED TO TWO FACING SURFACES," which was filed on Aug. 17, 2010, the entire contents of which are incorporated herein by reference.

FEDERAL RESEARCH STATEMENT

[0002] This invention was conceived under contract no. 1320783 with the National Air and Space Administration (NASA) having an effective date of Mar. 11, 2008 and relating to differential growth of elements requiring a thermal-mechanical coupler with a low effective Young's Modulus. This invention is unclassified.

BACKGROUND OF THE INVENTION

[0003] The subject matter disclosed herein relates to a high temperature thermal expansion compensator.

[0004] High-temperature thermoelectric materials are generally brittle, they have a relatively high Young's Modulus and relatively low allowable strain. They also exhibit low ultimate tensile strength. Several classes of thermoelectric materials exist with different values for their coefficients of thermal expansion. When thermoelectric materials from two different classes are combined to form a new thermoelectric couple, then, the difference in their coefficient of thermal expansions requires that a compensation device be included within the structural frame of the couple to prevent buildup of high stress levels in the thermoelectric couple legs and their potential to fracture.

[0005] The required properties for such a compensator include a very low effective Young's Modulus, they should allow for high elastic strain, they should be compatible with the operating environment and have the capability to demonstrate metallurgical bonding of the compensator into the thermoelectric couple's electrodes. There are no known materials, or combination of materials in the form of graded structures, which can satisfy all four criteria for the compensator simultaneously.

BRIEF DESCRIPTION OF THE INVENTION

[0006] According to one aspect of the invention, a thermal expansion compensator is provided and includes a first electrode structure having a first surface, a second electrode structure having a second surface facing the first surface and an elastic element bonded to the first and second surfaces and including a conductive element by which the first and second electrode structures electrically and/or thermally communicate, the conductive element having a length that is not substantially longer than a distance between the first and second surfaces.

[0007] According to another aspect of the invention, a thermal expansion compensator is provided and includes a first electrode structure having a first surface, a second electrode structure having a second surface facing the first surface and a series of coils arranged side-by-side and between the first and second electrode structures with respective portions of

each of the coils metallurgically bonded to corresponding portions of the first and second surfaces.

[0008] According to another aspect of the invention, a thermal expansion compensator is provided and includes a first electrode structure having a first surface, a second electrode structure having a second surface facing the first surface and wiring, including two or more wire sections, each of which is coiled to form a coil section having opposing ends corresponding to opposing wire section ends and sides extending therebetween, each of the coil sections being disposed side-long between the first and second electrode structures with respective portions of each of the coil section sides metallurgically bonded to corresponding portions of the first and second surfaces.

[0009] According to another aspect of the invention, a thermal expansion compensator is provided and includes a first electrode structure having a first surface, a second electrode structure having a second surface facing the first surface and wiring, including two or more wire sections, each of which is coiled to form a coil section having opposing ends corresponding to opposing wire section ends and sides extending therebetween, each of the coil sections being disposed between the first and second electrode structures such that longitudinal axes thereof are substantially parallel with respective planes of the first and second surfaces with respective portions of each of the coil section sides metallurgically bonded to corresponding portions of the first and second surfaces.

[0010] According to yet another aspect of the invention, a method of assembling a thermal expansion compensator is provided and includes disposing coils with pins inserted therein on a first foil layer disposed on a first electrode, disposing a second foil layer and then a second electrode on the pins and the coils, loading and then bonding the coils to the first and second foils layers and the first and second foil layers to the first and second electrodes to form an assembly, removing the pins and compressing the assembly in a direction perpendicular to a longitudinal direction of the coils to achieve a coil compression.

[0011] These and other advantages and features will become more apparent from the following description taken in conjunction with the drawings.

BRIEF DESCRIPTION OF THE DRAWING

[0012] The subject matter which is regarded as the invention is particularly pointed out and distinctly claimed in the claims at the conclusion of the specification. The foregoing and other features, and advantages of the invention are apparent from the following detailed description taken in conjunction with the accompanying drawings in which:

[0013] FIG. 1 is a side view of a thermal expansion compensator metallurgically bonded to electrodes;

[0014] FIG. 2 is another side view of the compensator metallurgically bonded to electrodes; and

[0015] FIG. 3A is an axial view of a first pin inserted into a coil; and

[0016] FIG. 3B is an axial view of a second pin inserted into the coil of FIG. 3A having been compressed.

[0017] The detailed description explains embodiments of the invention, together with advantages and features, by way of example with reference to the drawings.

DETAILED DESCRIPTION OF THE INVENTION

[0018] With reference to FIGS. 1 and 2, a thermal expansion compensator 10 is provided and includes a first electrode

structure **11** having a first surface **12**, a second electrode structure **13** having a second surface **14** facing the first surface **12** and an elastic element bonded to the first and second surfaces **12** and **14**. The elastic element includes an electrically and/or thermally conductive element by which the first and second electrode structures **11** and **13** electrically and/or thermally communicate with one another along pathways defined by the electrically and/or thermally conductive element. The electrically and/or thermally conductive element has a length that is not substantially longer than a distance between the first and second surfaces.

[0019] The elastic element may include cushioning resin or epoxy that is conductive or in which the conductive element is suspended, memory foam that is conductive or in which the conductive element is suspended, coils laid on end, coils laid on their sides as described below, leaf springs or similar types of elastic or cushioning devices. In any case, the pathways along which the first and second electrode structures **11** and **13** electrically and/or thermally communicate have respective lengths that are equal to or slightly longer than the distance between the first and second surfaces **12** and **14**. That is, if the distance between the first and second surfaces **12** and **14** is X , the respective lengths of the pathways may be X to about $2X$.

[0020] In accordance with embodiments, the thermal expansion compensator **10** is provided and includes the first electrode structure **11** having the first surface **12**, the second electrode structure **13** having the second surface **14**, which faces the first surface **12** and a series of coils **15** arranged side-by-side and between the first and second electrode structures **11** and **13** with respective portions **155** of each of the coils **15** metallurgically bonded to corresponding portions **111** and **133** of the first and second surfaces **12** and **14**.

[0021] The coils **15** may be provided in numbers of two or more and may be formed of wiring, including two or more wire sections **20**, **21**, where each wire section **20**, **21** is coiled into a coil section **25**. The coil section **25** has opposing ends **26**, **27** that correspond to opposing wire section ends **28**, **29** and sides **30** extending between the opposing ends **26**, **27**. Each of the coil sections **25** may be disposed sidelong between the first and second electrode structures **11** and **13** such that longitudinal axes, A_L , of the coil sections **25** are substantially parallel with planes, P_1 and P_2 , of the first and second electrode structures **11** and **13**. With the coil sections **25** disposed in this manner, the respective portions **155** of for example each of the coil section sides **30** are metallurgically bonded to the corresponding portions **111**, **133** of the first and second surfaces **12** and **14**.

[0022] The coils **15** may include helical coiling with, for example, **85** turns per $0.285''$ or about **300** turns per inch. The coils **15** may be separate from one another, as shown in FIG. **1** or, in some cases, provided as a continuous serpentine structure whereby the coils **15** include substantially straight portions and, for example, hairpin sections. In any case, the coils **15** include wires or wiring having a relatively small diameter relative to a distance between the first and second electrode structures **11** and **13**.

[0023] The first electrode structure **11** includes a base **40** formed of molybdenum (Mo) and, in some cases, stainless steel or similar materials. The first electrode **11** further includes a titanium (Ti) layer **41** at the first surface **12**. Like the base, the coils **15** may be formed of molybdenum. The second electrode structure **13** is arranged similarly with a molybdenum base **50** and a titanium layer **51**. In this way, when the thermal expansion compensator **10** is assembled,

during a bonding process in which the thermal expansion compensator is loaded and heated to about **760** degrees Celsius for about **120** minutes, the molybdenum of the respective bases **40**, **50** diffusion bonds with the titanium layers **41**, **51** of the respective first and second surfaces **12** and **14**. Similarly, the titanium layers **41**, **51** of the respective first and second surfaces **12** and **14** diffusion bonds with the molybdenum of the coils **15** at the respective portions **155**. Since the bonding temperature is relatively low as compared to, for example, the melting temperatures of components associated with the thermal expansion compensator **10**, damage to those components during the bonding process can be avoided or substantially reduced.

[0024] The thermal expansion compensator **10** described herein thus employs a set of, for example, helical coils **15**, made from relatively small diameter wire, which are laid on their sides **30**. These coils **15** are metallurgically bonded into the first and second electrode structures **11** and **13**. Once the bonding is achieved, the coils **15** act like springs in the orthogonal direction allowing elastic compression of each wire ring for a relatively low deflection force. Models of coil diametrical deflection with applied force can be applied to predict overall force-deflection behavior and to calculate its effective spring constant. In the thermal expansion compensator **10**, therefore soft compliance (i.e., thermal expansion) is possible along with low thermal and electrical impedance. In particular, a relatively very low effective Young's Modulus is achieved under relatively high elastic strain levels of **15%** or greater.

[0025] Coil diameter and coil-to-wire outside diameter ratios can be varied in the design of the thermal expansion compensator **10** to change the desired elastic deflection range. The number of coils **15**, the wire material and its treatment and the number of turns per inch of coil **15** can be changed to adjust the effective spring constant. The wire material can be selected or a twisted wire rope construction can be used for different operating environments and other uses.

[0026] In accordance with further aspects of the invention, the thermal expansion compensator **10** is assembled with reference to FIG. **3A**. Initially, the coils **15** are formed and positioned onto pins **60**, such as temporary molybdenum pins, and held with a holder. The holder, the pins **60** and the coils **15** are then positioned on temporary foil for subsequent transfer. A layer **41** of titanium foil ($0.0005''$ thick) is then placed onto a molybdenum base **40** of the first (hot) electrode structure **11** and the holder, the pins **60** and the coils **15** are placed on top of the titanium layer **41**. At this point, positions of the pin **60** and the titanium layer **41** are verified and a second titanium layer **51** is placed on top of the coils **15**. The base **50** of the second electrode structure **13** is then placed on the layer **51**, a remainder of tooling for applying load is installed and the structure is transferred to, for example, a furnace hearth where load application may be prepared.

[0027] The bonding process includes application of a downward load to the base **50** of the second electrode structure **13** and across the coils **15** to be bonded. Bonding is then performed at about **760** degrees Celsius for about **120** minutes. Once the bonding is complete, the pins **60** are removed from the coils **15** under a microscope as is necessary. Following pin **60** removal, the coils **15** may be optionally compressed using tooling to precisely control a position of the base **50**. Thus, the thermal expansion compensator **10** assembly can be compressed to provide a desired compression of the coils **15** perpendicular to their longitudinal axes, A_L . This

compression is optional and may be carried out to modify the coil shape, as shown in FIG. 3B, and thereby to modify the effective Young's modulus of the assembly.

[0028] With reference to FIG. 3B, a second optional bond cycle may be employed to provide for additional bonding beyond that which is achieved in the initial bonding. Here, a second set of pins 70, such as molybdenum pins or stainless steel pins, are selected and sized to precisely fit the inner diameter obtained in the coil 15 compression. The second pins 70 are installed and provide support during a second loading and bonding sequence, which is substantially similar to the initial sequence.

[0029] While the invention has been described in detail in connection with only a limited number of embodiments, it should be readily understood that the invention is not limited to such disclosed embodiments. Rather, the invention can be modified to incorporate any number of variations, alterations, substitutions or equivalent arrangements not heretofore described, but which are commensurate with the spirit and scope of the invention. Additionally, while various embodiments of the invention have been described, it is to be understood that aspects of the invention may include only some of the described embodiments. Accordingly, the invention is not to be seen as limited by the foregoing description, but is only limited by the scope of the appended claims.

1. A method of assembling a thermal expansion compensator, the method comprising:
 disposing coils with pins inserted therein on a first foil layer disposed on a first electrode;
 disposing a second foil layer and then a second electrode on the pins and the coils;

loading and then bonding the coils to the first and second foil layers and the first and second foil layers to the first and second electrodes to form an assembly; and
 removing the pins.

2. The method according to claim 1, further comprising compressing the assembly in a direction perpendicular to a longitudinal direction of the coils to achieve a coil compression.

3. The method according to claim 1, wherein the coils comprise molybdenum (Mo), the first and second foil layers comprise titanium (Ti) and the first and second electrodes comprise molybdenum (Mo).

4. The method according to claim 1, wherein the bonding comprises bonding at about 760 degrees Celsius for about 120 minutes.

5. The method according to claim 1, further comprising performing a second bonding operation to increase the bonding between the coils and the first and second foils layers and between the first and second foil layers to the first and second electrodes.

6. The method according to claim 5, wherein the performing of the second bonding operation comprises inserting second pins to tightly fit within the coils.

7. A method of assembling a thermal expansion compensator, the method comprising:

disposing coils on a first foil layer disposed on a first electrode;

disposing a second foil layer and then a second electrode on the coils;

bonding the coils to the first and second foil layers; and
 bonding the first and second foil layers to the first and second electrodes.

* * * * *