

(12) STANDARD PATENT
(19) AUSTRALIAN PATENT OFFICE

(11) Application No. **AU 2018284233 B2**

(54) Title
Fluid removal management and control of wound closure in wound therapy

(51) International Patent Classification(s)
A61M 1/00 (2006.01) **A61F 13/00** (2006.01)

(21) Application No: **2018284233** (22) Date of Filing: **2018.06.12**

(87) WIPO No: **WO18/231878**

(30) Priority Data

(31) Number	(32) Date	(33) Country
62/519,781	2017.06.14	US
62/519,787	2017.06.14	US

(43) Publication Date: **2018.12.20**

(44) Accepted Journal Date: **2024.01.04**

(71) Applicant(s)
Smith & Nephew, Inc.

(72) Inventor(s)
Hunt, Allan Kenneth Frazer Grugeon;Jaecklein, William Joseph;Quintanar, Felix Clarence

(74) Agent / Attorney
Griffith Hack, Level 10 161 Collins St, MELBOURNE, VIC, 3000, AU

(56) Related Art
WO 2016/018448 A1
US 2013/0150813 A1
US 2016/0184496 A1
US 2008/0243096 A1



(51) International Patent Classification:
A61M 1/00 (2006.01) A61F 13/00 (2006.01)

(21) International Application Number:
PCT/US2018/037169

(22) International Filing Date:
12 June 2018 (12.06.2018)

(25) Filing Language: English

(26) Publication Language: English

(30) Priority Data:
62/519,781 14 June 2017 (14.06.2017) US
62/519,787 14 June 2017 (14.06.2017) US

(71) Applicant: SMITH & NEPHEW, INC. [US/US]; 1450 Brooks Road, Memphis, Tennessee 38116 (US).

(72) Inventors: HUNT, Allan Kenneth Frazer Grugeon; c/o Smith & Nephew Patent Department, PO Box 81, 101 Hessle Road, Hull HU3 2BN (GB). JAECKLEIN, William Joseph; c/o Smith & Nephew Patent Department, PO Box

81, 101 Hessle Road, Hull HU3 2BN (GB). QUINTANAR, Felix Clarence; c/o Smith & Nephew Patent Department, PO Box 81, 101 Hessle Road, Hull HU3 2BN (GB).

(74) Agent: ALTMAN, Daniel E.; KNOBBE, MARTENS, OLSON & BEAR, LLP, 2040 Main Street, 14th Floor, Irvine, California 92614 (US).

(81) Designated States (unless otherwise indicated, for every kind of national protection available): AE, AG, AL, AM, AO, AT, AU, AZ, BA, BB, BG, BH, BN, BR, BW, BY, BZ, CA, CH, CL, CN, CO, CR, CU, CZ, DE, DJ, DK, DM, DO, DZ, EC, EE, EG, ES, FI, GB, GD, GE, GH, GM, GT, HN, HR, HU, ID, IL, IN, IR, IS, JO, JP, KE, KG, KH, KN, KP, KR, KW, KZ, LA, LC, LK, LR, LS, LU, LY, MA, MD, ME, MG, MK, MN, MW, MX, MY, MZ, NA, NG, NI, NO, NZ, OM, PA, PE, PG, PH, PL, PT, QA, RO, RS, RU, RW, SA, SC, SD, SE, SG, SK, SL, SM, ST, SV, SY, TH, TJ, TM, TN, TR, TT, TZ, UA, UG, US, UZ, VC, VN, ZA, ZM, ZW.

(84) Designated States (unless otherwise indicated, for every kind of regional protection available): ARIPO (BW, GH,

(54) Title: FLUID REMOVAL MANAGEMENT AND CONTROL OF WOUND CLOSURE IN WOUND THERAPY

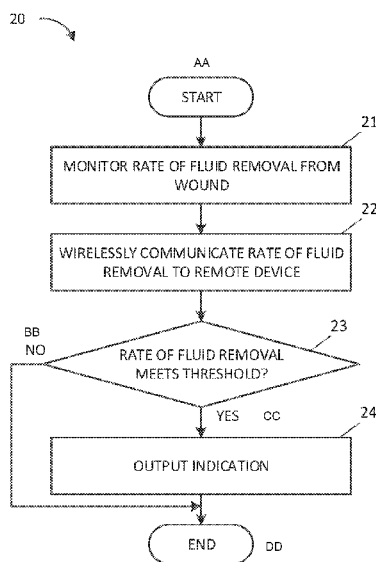

FIG. 4A

(57) Abstract: Embodiments of negative pressure wound therapy systems and methods for operating the systems are disclosed. In one embodiment, a negative pressure wound therapy apparatus can include a wound dressing, a negative pressure source, and a controller. The negative pressure source can provide negative pressure via a fluid flow path to the wound dressing. The controller can monitor a rate of fluid removal from the wound, wirelessly communicate the rate of fluid removal to a remote device, and output an indication when the rate of fluid removal meets a threshold.



GM, KE, LR, LS, MW, MZ, NA, RW, SD, SL, ST, SZ, TZ, UG, ZM, ZW), Eurasian (AM, AZ, BY, KG, KZ, RU, TJ, TM), European (AL, AT, BE, BG, CH, CY, CZ, DE, DK, EE, ES, FI, FR, GB, GR, HR, HU, IE, IS, IT, LT, LU, LV, MC, MK, MT, NL, NO, PL, PT, RO, RS, SE, SI, SK, SM, TR), OAPI (BF, BJ, CF, CG, CI, CM, GA, GN, GQ, GW, KM, ML, MR, NE, SN, TD, TG).

Declarations under Rule 4.17:

- *as to applicant's entitlement to apply for and be granted a patent (Rule 4.17(ii))*
- *as to the applicant's entitlement to claim the priority of the earlier application (Rule 4.17(iii))*

Published:

- *with international search report (Art. 21(3))*
- *before the expiration of the time limit for amending the claims and to be republished in the event of receipt of amendments (Rule 48.2(h))*

FLUID REMOVAL MANAGEMENT AND CONTROL OF WOUND CLOSURE IN WOUND THERAPY

CROSS-REFERENCE TO RELATED APPLICATIONS

[0001] This application claims priority to U.S. Provisional Application No. 62/519787, filed on June 14, 2017, and U.S. Provisional Application No. 62/519781, filed on June 14, 2017; the disclosures of both applications are hereby incorporated by reference in their entirety.

BACKGROUND

[0002] Embodiments of the present disclosure relate to methods and apparatuses for dressing and providing therapy to a wound. In particular, but without limitation, embodiments disclosed herein relate to negative pressure therapy devices, methods for controlling the operation of topical negative pressure (TNP) systems, and methods of using TNP systems.

SUMMARY

[0003] In some embodiments, a wound therapy apparatus is disclosed. The wound therapy apparatus includes: a wound dressing comprising a stabilizing structure configured to be inserted into a wound; a negative pressure source configured to provide negative pressure via a fluid flow path to the wound dressing; and a controller. The controller is configured to: monitor a rate of fluid removal from the wound and wirelessly communicate the rate of fluid removal to a remote device, and output an indication when the rate of fluid removal meets a threshold.

[0004] The wound therapy apparatus of the preceding paragraph can include one or more of the following features: The controller is further configured to cause the negative pressure source to adjust a level of negative pressure provided to the wound dressing when the rate of fluid removal meets the threshold. The controller is further configured to monitor the rate of fluid removal from a weight of fluid aspirated from the wound. The controller is further configured to monitor the weight of fluid aspirated from the wound and a weight of fluid stored in a canister. The wound therapy apparatus can further include a pressure sensor configured to

monitor one or more characteristics of pressure in the fluid flow path, and wherein the controller is further configured to monitor the rate of fluid removal using the one or more characteristics of pressure. The wound therapy apparatus can further include a canister configured to store fluid removed from the wound, and wherein the controller is further configured to monitor the rate of fluid removal from a level of fluid in the canister. The controller is further configured to monitor the level of fluid in the canister using one or more characteristics of pressure in the fluid flow path. The controller is further configured to monitor the level of fluid in the canister from an activity level of the negative pressure source. The negative pressure source comprises a vacuum pump, and the activity level of the negative pressure source corresponds to a speed of the vacuum pump. The one or more characteristics of pressure comprises a magnitude of pressure signals, and the magnitude of pressure signals increases as the level of fluid in the canister increases. The controller is further configured to wirelessly communicate the rate of fluid removal to the remote device to cause the remote device to store the rate of fluid removal in an electronic medical record associated with the patient.

[0005] In some embodiments, a method of operating a negative pressure wound therapy apparatus comprising a controller and a negative pressure source is disclosed. The negative pressure source is configured to provide negative pressure via a fluid flow path to a wound dressing, the wound dressing comprising a stabilizing structure inserted into a wound. The method includes: monitoring a rate of fluid removal from the wound; wirelessly communicating the rate of fluid removal to a remote device; and outputting an indication when the rate of fluid removal meets a threshold. The method is performed by the controller.

[0006] The method of the preceding paragraph can include one or more of the following features: The method further includes adjusting a level of negative pressure provided by the negative pressure source to the wound dressing when the rate of fluid removal meets the threshold. The monitoring the rate of fluid removal comprises monitoring the rate of fluid removal from a weight of fluid aspirated from the wound. The monitoring the rate of fluid removal comprises monitoring the weight of fluid aspirated from the wound and a weight of fluid absorbed by the wound

dressing or stored in a canister. The method further includes monitoring one or more characteristics of pressure in the fluid flow path, and wherein the monitoring the rate of fluid removal comprises monitoring the rate of fluid removal using the one or more characteristics of pressure. The monitoring the rate of fluid removal comprises monitoring the rate of fluid removal from a level of fluid in a canister that stores fluid removed from the wound. The monitoring the rate of fluid removal comprises monitoring the level of fluid in the canister using one or more characteristics of pressure in the fluid flow path. The monitoring the rate of fluid removal comprises monitoring the level of fluid in the canister from an activity level of the negative pressure source. The negative pressure source comprises a vacuum pump, and the activity level of the negative pressure source corresponds to a speed of the vacuum pump. The one or more characteristics of pressure comprises a magnitude of pressure signals, and wherein the magnitude of pressure signals increases as the level of fluid in the canister increases. The wirelessly communicating the rate of fluid removal comprises wirelessly communicating the rate of fluid removal to the remote device to cause the remote device to store the rate of fluid removal in an electronic medical record associated with the patient.

[0007] In a first aspect, the invention provides a wound therapy apparatus comprising: a negative pressure source configured to provide negative pressure via a fluid flow path to a wound dressing comprising a stabilizing structure, the stabilizing structure being configured to be inserted into a wound and collapse upon application of negative pressure to the wound when the stabilizing structure is positioned in the wound; a sensor configured to detect pressure in the fluid flow path; and a controller configured to: determine a measure of collapse of the stabilizing structure from the pressure in the fluid flow path while the negative pressure source maintains a magnitude of the pressure in the fluid flow path within a negative pressure range; and output an indication responsive to the measure of collapse.

[0008] The wound therapy apparatus of the preceding paragraph can include one or more of the following features: The controller is configured to determine the measure of collapse from a change in the magnitude of the pressure

in the fluid flow path over time. The controller is further configured to determine the measure of collapse from a comparison of the magnitude of the pressure in the fluid flow path over time to a pressure change pattern. The pressure change pattern is indicative of one or more of: (i) pressure magnitude in the fluid flow path when the stabilizing structure is fully collapsed, (ii) pressure magnitude in the fluid flow path when the stabilizing structure is partially collapsed, or (iii) pressure magnitude in the fluid flow path when the stabilizing structure is not collapsed. The measure of collapse comprises a rate of collapse of the stabilizing structure. The controller is further configured to detect that a suture burst or failed from the pressure in the fluid flow path, the suture being proximate to the wound dressing. The controller is configured to output the indication to (i) activate or deactivate the negative pressure source, (ii) activate or deactivate an alarm, (iii) increase or decrease a target negative pressure provided by the negative pressure source, or (iv) release negative pressure in the fluid flow path. The controller is configured to output the indication to control activation and deactivation of the negative pressure source for a time period according to a target level of collapse of the stabilizing structure rather than to control activation and deactivation of the negative pressure source to adjust the magnitude of the pressure in the fluid flow path to target a predetermined negative pressure threshold. The time period is at least 1 minutes, 5 minutes, 10 minutes, 30 minutes, 1 hour, or 5 hours. The controller is configured to output the indication for presentation to a user or storage in a memory device. The controller is further configured to store, in a memory device, device usage data in association with the indication, and the device usage data comprises one or more of a pressure level, an alarm, an exudate level, an event log, and an operation use time. The controller is further configured to determine whether the wound dressing comprises the stabilizing structure from the pressure in the fluid flow path. The sensor is configured to detect the pressure in the fluid flow path at the wound dressing, in one or more lumens of the fluid flow path, or at an inlet of the negative pressure source. The negative pressure source is configured to perform negative pressure therapy when the magnitude of the pressure in the fluid flow path is maintained within the negative pressure range.

[0009] In a second aspect, the invention provides, a method of operating a wound therapy apparatus comprising a controller and a negative pressure source configured to provide negative pressure via a fluid flow path to a wound dressing, the wound dressing comprising a stabilizing structure, the stabilizing structure configured to be inserted into a wound and further configured to collapse upon application of negative pressure to the wound when the stabilizing structure is positioned in the wound, the method comprising: monitoring pressure in the fluid flow path; determining a measure of collapse of the stabilizing structure from the pressure in the fluid flow path while the negative pressure source maintains a magnitude of the pressure in the fluid flow path within a negative pressure range; and outputting an indication responsive to the measure of collapse, wherein the method is performed by the controller.

[0010] The method of the preceding paragraph can include one or more of the following features: The determining the measure of collapse comprises determining the measure of collapse from a change in the magnitude of the pressure in the fluid flow path over time. The determining the measure of collapse comprises determining the measure of collapse from a comparison of the magnitude of the pressure in the fluid flow path over time to a pressure change pattern. The pressure change pattern is indicative of one or more of: (i) pressure magnitude in the fluid flow path when the stabilizing structure is fully collapsed, (ii) pressure magnitude in the fluid flow path when the stabilizing structure is partially collapsed, or (iii) pressure magnitude in the fluid flow path when the stabilizing structure is not collapsed. The measure of collapse comprises a rate of collapse of the stabilizing structure. The outputting the indication comprises outputting the indication to (i) activate or deactivate the negative pressure source, (ii) activate or deactivate an alarm, (iii) increase or decrease a target negative pressure provided by the negative pressure source, or (iv) release negative pressure in the fluid flow path. The outputting the indication comprises outputting the indication to control activation and deactivation of the negative pressure source for a time period according to a target level of collapse of the stabilizing structure rather than to control activation and deactivation of the negative pressure source to adjust the magnitude of pressure to target a

predetermined negative pressure threshold. The time period is at least 1 minutes, 5 minutes, 10 minutes, 30 minutes, 1 hour, or 5 hours. The outputting the indication comprises outputting the indication for presentation to a user or storage in a memory device. The method can further include storing, in a memory device, device usage data in association with the indication, and the device usage data comprises one or more of a pressure level, an alarm, an exudate level, an event log, and an operation use time. The method can further include determining whether the wound dressing comprises the stabilizing structure from the pressure in the fluid flow path. The monitoring the pressure in the fluid flow path comprises monitoring the pressure in the fluid flow path at the wound dressing, in one or more lumens of the fluid flow path, or at an inlet of the negative pressure source. The negative pressure source is configured to perform negative pressure therapy when a magnitude of the pressure in the fluid flow path is maintained within the negative pressure range.

BRIEF DESCRIPTION OF THE DRAWINGS

[0011] Features and advantages of the present disclosure will be apparent from the following detailed description, taken in conjunction with the accompanying drawings of which:

[0012] Figs. 1, 2, and 3 illustrate embodiments of a negative pressure treatment system.

[0013] Fig. 4A illustrates a fluid removal management process according to some embodiments.

[0014] Fig. 4B illustrates a collapse monitoring process according to some embodiments.

[0015] Fig. 5 illustrates a graph of pressure signals according to some embodiments.

[0016] Figs. 6A-C illustrate multiple views of an embodiment of a stabilizing structure.

[0017] Fig. 7 illustrates an embodiment of an open abdominal wound.

[0018] Fig. 8 illustrates an embodiment of a step in a method of treating a wound.

[0019] Fig. 9 illustrates an embodiment of a step in a method of treating a wound.

[0020] Figs. 10A-C illustrate an embodiment of steps of a method of treating a wound.

[0021] Figs. 11A-B illustrate steps of a method of treating a wound.

[0022] Figs. 12A-C depict an embodiment of steps of a method of treating a wound.

[0023] Fig. 13 illustrates embodiments of steps of a method of treating a wound.

[0024] Figs. 14A-G illustrate an embodiment of a method of treating a wound.

[0025] Figs. 15A-E illustrate an embodiment of a method of treating a wound.

DETAILED DESCRIPTION

Introduction

[0026] The present disclosure relates to methods and apparatuses for dressing and treating a wound with reduced pressure therapy or topical negative pressure (TNP) therapy, as well positive pressure therapy or wound care that is not aided by applied pressure. In particular, but without limitation, embodiments of this disclosure relate to negative pressure therapy apparatuses, methods for controlling the operation of TNP systems, and methods of using TNP systems. The methods and apparatuses can incorporate or implement any combination of the features described below.

[0027] The apparatuses and components including the wound overlay and packing materials, if any, are sometimes collectively referred to herein as wound dressings.

[0028] It will be appreciated that throughout this specification reference is made to a wound. It is to be understood that the term wound is to be broadly construed and encompasses open and closed wounds in which skin is torn, cut or punctured or where trauma causes a contusion, or any other superficial or other

conditions or imperfections on the skin of a patient or otherwise that benefit from reduced pressure treatment. A wound is thus broadly defined as any damaged region of tissue where fluid may or may not be produced. Examples of such wounds include, but are not limited to, abdominal wounds or other large or incisional wounds, either as a result of surgery, trauma, sterniotomies, fasciotomies, or other conditions, dehisced wounds, acute wounds, chronic wounds, subacute and dehisced wounds, traumatic wounds, flaps and skin grafts, lacerations, abrasions, contusions, burns, electrical burns, diabetic ulcers, pressure ulcers, stoma, surgical wounds, trauma and venous ulcers or the like.

[0029] As is used in this section or elsewhere in this specification, reduced or negative pressure levels, such as $-X$ mmHg, represent pressure levels that are below atmospheric pressure, which typically corresponds to 760 mmHg (or 1 atm, 29.93 inHg, 101.325 kPa, 14.696 psi, etc.). Accordingly, a negative pressure value of $-X$ mmHg reflects pressure that is X mmHg below atmospheric pressure, such as a pressure of $(760-X)$ mmHg. In addition, negative pressure that is “less” or “smaller” than $-X$ mmHg corresponds to pressure that is closer to atmospheric pressure (e.g., -40 mmHg is less than -60 mmHg). Negative pressure that is “more” or “greater” than $-X$ mmHg corresponds to pressure that is further from atmospheric pressure (e.g., -80 mmHg is more than -60 mmHg).

[0030] The negative pressure range for some embodiments of the present disclosure can be approximately -80 mmHg, or between about -10 mmHg and -200 mmHg. Note that these pressures are relative to normal ambient atmospheric pressure. Thus, -200 mmHg would be about 560 mmHg in practical terms. In some embodiments, the pressure range can be between about -40 mmHg and -150 mmHg. Alternatively, a pressure range of up to -75 mmHg, up to -80 mmHg or over -80 mmHg can be used. Also in other embodiments a pressure range of below -75 mmHg can be used. Alternatively, a pressure range of over approximately -100 mmHg, or even -150 mmHg, can be supplied by the negative pressure apparatus. In some embodiments, the negative pressure range can be as small as about -20 mmHg or about -25 mmHg, which may be useful to reduce fistulas. In some embodiments of wound closure devices described here, increased wound

contraction can lead to increased tissue expansion in the surrounding wound tissue. This effect may be increased by varying the force applied to the tissue, for example by varying the negative pressure applied to the wound over time, possibly in conjunction with increased tensile forces applied to the wound via embodiments of the wound closure devices. In some embodiments, negative pressure may be varied over time for example using a sinusoidal wave, square wave, or in synchronization with one or more patient physiological indices (e.g., heartbeat).

[0031] Examples of such applications where additional disclosure relating to the preceding descriptions may be found include U.S. Patent No. 8,235,955, titled “Wound treatment apparatus and method,” issued August 7, 2012 and U.S. Patent No. 7,753,894, titled “Wound cleansing apparatus with stress,” issued July 13, 2010. Both applications are hereby incorporated by reference in their entirety. Other applications that may contain teachings relevant for use with the embodiments described in this section or elsewhere in this specification may include Application Serial No. 12/886,088, titled “Systems And Methods For Using Negative Pressure Wound Therapy To Manage Open Abdominal Wounds,” filed September 20, 2010, published as US 2011/0213287; Application Serial No. 13/092,042, titled “Wound Dressing And Method Of Use,” filed April 21, 2011, published as US 2011/0282309; and Application Serial No. 13/365,615, titled “Negative Pressure Wound Closure Device,” filed February 3, 2012, published as US 2012/0209227, the entireties of each of which are hereby incorporated by reference. Still more applications that may contain teachings relevant for use with the embodiments described in this specification are Application Serial No. 13/942,493, titled “Negative Pressure Wound Closure Device,” filed July 15, 2013, published as US 2014/0180225; PCT App. No. PCT/US2013/050619, filed July 16, 2013 titled “Negative Pressure Wound Closure Device,” published as WO 2014/014871 A1; PCT App. No. PCT/US2013/050698, filed July 16, 2013 titled “Negative Pressure Wound Closure Device,” published as WO 2014/014922 A1; PCT App. No. PCT/IB2013/01555, titled “Devices and Methods for Treating and Closing Wounds with Negative Pressure,” filed May 5, 2013, published as WO 2013/175309 A1; PCT App. No. PCT/US2014/025059, titled “Negative Pressure Wound Closure Device and Systems and Methods of Use in

Treating Wounds with Negative Pressure,” filed March 12, 2014, published as WO 2014/165275 A1; and PCT App. No. PCT/GB2014/050746, “Compressible Wound Fillers and Systems and Methods of Use In Treating Wounds With Negative Pressure,” filed Mar 13, 2014, published as WO 2014/140578 A1, and “Negative Pressure Wound Closure Device,” filed Oct 21, 2014, and published as PCT/US2014/061627. The entireties of the aforementioned applications are each hereby incorporated by reference and should be considered part of the present specification.

[0032] It will be understood that throughout this specification in some embodiments reference is made to an elongate, elongated or longitudinal strip or strips. It is to be understood that these terms are to be broadly construed and refer in some embodiments to an elongate material having two parallel or substantially parallel faces, where in cross-section a thickness of the material as measured perpendicular to the faces is relatively smaller than a height of the material measured parallel to the faces. While in some embodiments the strips may be constructed from discrete lengths of material, in other embodiments the strips may simply refer to elongate portions of an overall structure having two parallel or substantially parallel faces. The strips in some embodiments have a rectangular or generally rectangular-shaped faces, wherein a length of the face is longer than the height of the face. In some embodiments, the length of the face may be more than 2 times, 4 times, 6 times, 8 times, 10 times, 12 times or more greater than the height of the face.

[0033] As used in this section or elsewhere in this specification, the term “horizontal,” when referring to a wound, indicates a direction or plane generally parallel to the skin surrounding the wound. The term “vertical,” when referring to a wound, generally refers to a direction extending perpendicular to the horizontal plane. The term “longitudinal,” when referring to a wound, generally refers to a direction in the horizontal plane taken in a direction along which the wound is longest. The term “lateral,” when referring to a wound, generally refers to a direction in the horizontal plane perpendicular to the longitudinal direction. The terms “horizontal,” “vertical,” “longitudinal,” and “lateral” may also be used to describe the

stabilizing structures and wound closure devices described throughout this specification. When describing these structures or devices, these terms should not be construed to require that the structures or devices necessarily be placed into a wound in a certain orientation, though in certain embodiments, it may be preferable to do so.

[0034] Although one or more features described herein may be discussed in the context of negative pressure wound therapy, the one or more features can apply to other contexts like positive pressure wound therapy or traditional wound therapy without application of pressure.

Overview

[0035] During treatment of a patient's wound using a TNP apparatus, the TNP apparatus may remove fluids including wound exudate from the wound. To help ensure that fluid removal from the wound remains within acceptable performance limits for the TNP apparatus and acceptable health or comfort limits for the patient, the TNP apparatus can include a controller that automatically monitors and tracks a volume or rate of fluid removal from the wound, such as a total volume of fluid removal, an instantaneous rate of fluid removal, or a rate of fluid removal per time period (such as over a last five or last one hour). The controller can use one or more sensors to monitor the volume or rate of fluid removal, communicate data to another device, control operation of the TNP apparatus, or provide an indication to a user of the TNP apparatus responsive to the volume or rate of fluid removal.

[0036] The one or more sensors used by the controller to monitor the volume or rate of fluid removal can, for example, include a scale, a level sensor, a pressure sensor, or an activity sensor. The scale can measure a weight of fluid removed from the wound, for instance, by weighing a canister or a wound dressing (which can also be or include any of the wound closure devices described herein) that collects and stores fluid removal from the wound. Because the weight of removed fluid can be generally proportional to the volume of fluid removal, the controller can use the weight to monitor the volume or rate of fluid removal. The fluid level sensor can measure a level of fluid in a canister (or wound dressing) which

collects and stores fluid removed from the wound. The level of fluid in the canister (or wound dressing) can be generally proportional to the volume of removed fluid and thus can be used by the controller to monitor the volume or rate of fluid removal. The pressure sensor can measure pressure in a fluid flow path through which the TNP apparatus provides negative pressure to the wound. The controller, in such implementations, can analyze one or more characteristics of pressure in the fluid flow path, such as magnitude of pressure pulses, to determine and monitor the volume or rate of fluid removal. The activity sensor can measure a level of activity of the TNP apparatus, such as a speed of a negative pressure source actuator (such as a motor) of the TNP apparatus, and the controller can use the level of activity to determine and monitor the volume or rate of fluid removal.

[0037] The controller can store in a memory device one or more values indicative of the volume or rate of fluid removal over time for additional processing. In one example, the controller may then manually in response to user input or automatically transmit the one or more values using a transmitter of the TNP apparatus to a remote device. The controller can, for instance, transmit via a wireless communication network the one or more values in a message that upon receipt by the remote device causes the remote device to store the one or more values in an electronic medical record associated with a user of the TNP apparatus or an individual prescribed to use the TNP apparatus. In another example, the controller can provide a notification (such as output an alarm) when the volume or rate of fluid removal meets a threshold that indicates an excess fluid removal or sudden increase or decrease in fluid removal. In yet another example, the controller can automatically increase or decrease one or more operational parameters, such as negative pressure provided by the TNP apparatus to the wound, according to the volume or rate of fluid removal.

[0038] The controller can moreover utilize information about a patient, such as patient metabolism or physiology or data from other treatment of the patient, in combination with the volume or rate of fluid removal to communicate data to another device, control operation of the TNP apparatus, or provide an indication to a user of the TNP apparatus. In one example, the controller can receive information

about a volume or rate of fluid that may be provided to the patient (which may include intravenous fluids, drugs, or painkillers) and use the volume or rate of fluid provided to the patient to adjust a threshold used to trigger activity by the TNP apparatus. It may be particularly important to ensure during the first few days of treating a wound that more fluids are going into a patient than are removed from the wound. Thus, the controller can, for instance, compare the volume of fluid provided to the patient with the volume of fluid removal from the wound and provide a notification (such as trigger an alarm) if the volume of fluid removal meets or exceeds the volume of fluid provided to the patient. The controller can additionally or alternatively automatically adjust one or more operational parameters, such as the level of negative pressure provided by the TNP apparatus, to attempt to decrease the rate of fluid removal from the wound. In another example, the controller can receive information about the metabolism or physiology of the patient and adjust a threshold used to trigger activity by the TNP apparatus responsive to the volume or rate of fluid removal. The controller, as a result, can be more sensitive to the volume or rate of fluid removal for certain individual than other individuals (such as more sensitive to the volume or rate of fluid removal in smaller individuals than larger individuals) or at certain times than other times (such as when a patient is in critical condition rather than in stable condition).

[0039] A wound dressing used in negative wound pressure therapy can include a wound matrix or a stabilizing structure configured to collapse when negative pressure is applied to a wound in which the stabilizing structure is placed or positioned, as well as when a wound closes and heals. The stabilizing structure can be rigid or substantially rigid. The collapse of the stabilizing structure, however, can be difficult to monitor once the stabilizing structure is placed in the wound because the stabilizing structure may be difficult to see within the wound or through a drape, foam, or another wound dressing component placed over the stabilizing structure.

[0040] A TNP apparatus can include a controller that monitors pressure in a fluid flow path connecting a source of negative pressure to a wound dressing including a stabilizing structure. The controller can advantageously, in certain embodiments, monitor a state of collapse of the stabilizing structure based on the

pressure in the fluid flow path. The stabilizing structure can change negative pressure wound therapy dynamics, such as during a continuous or an intermittent operation mode of the TNP apparatus, and the state of collapse of the stabilizing structure can cause pressure changes, noise, or artifacts, such as due to a non-homogeneous compression or decompression of the stabilizing structure. Such pressure artifacts may be detected and analyzed to determine the state of collapse of the stabilizing structure. For example, unlike foam which may become substantially flat when sufficient negative pressure is applied (such as, -80 mmHg) and may not collapse further even when negative pressure is increased, the stabilizing structure may collapse over a larger range of negative pressures. Collapse of the stabilizing structure can cause variations in the pressure levels, such as pressure artifacts. This may be due to the removal of air from the cells of the stabilizing structure, which causes its collapse.

[0041] The controller can, for example, determine a measure of collapse of the stabilizing structure from the pressure changes in the fluid flow path and output an indication responsive to the measure of collapse. The pressure changes can be detected using one or more pressure sensors in the fluid flow path. The measure of collapse can be determined, for instance, using one or more of a peak-to-peak magnitude of pressure variation, a statistical pressure algorithm, a pressure pattern matching, pressure micro-changes like in envelope changes in pressure signal, or pressure frequency variation, among other approaches. The measure of collapse can, in some instances, be a degree or rate of collapse of the stabilizing structure and indicative of a degree or rate of closure of the wound.

[0042] The controller can monitor the healing of the wound from the measure of collapse as the wound closes and heals. The healing or closing of the wound can cause the collapse of the stabilizing structure beyond what may be expected when a particular level of negative pressure is applied to the wound incorporating the stabilizing structure. As a result, the controller can determine that a degree or rate of collapse in excess of the degree or rate of collapse attributable to application of negative pressure may be attributable to wound healing or closure. In such implementations, the indication output by the controller can be output for

presentation to user and denote to replace the stabilizing structure with a smaller stabilizing structure that may be more appropriate for the wound since the wound has partially healed or closed.

[0043] The controller can control provision of wound therapy, a degree or rate of collapse of the stabilizing structure, a size of the wound, an amount or rate of fluid removed from the wound, or an amount or rate of pain experienced based on the measure of collapse. For example, the controller can, at least for a period of time (like 30 seconds, 1 minutes, 2 minutes, 3 minutes, 5 minutes, or 10 minutes) or for a number of compression or decompression cycles (like 2, 3, 5, 10, 20, or 50, compression-decompression cycles) activate or deactivate a negative pressure source according to the measure of collapse. Moreover, the controller can activate or deactivate the negative pressure source according to the measure of collapse in addition to or instead of controlling the negative pressure source to target a specific level or a range of negative pressure. Such control advantageously can, in certain embodiments, enable provision of therapy to be tailored to a particular wound, environment or patient (such as in a non-linear way), which thereby can enable faster, less painful, more effective, or more responsive therapy. In addition, such control may enable the controller to be more reactive to or prevent blockages in the fluid flow path because more tailored or customized negative pressure therapy can be applied based on, for example, measured fluid removal from the wound. For example, more appropriate level (or levels) of negative pressure can be continuously selected based on the measured fluid removal, which can result in a lessened risk of a blockage as negative pressure being applied in tailored to the rate of flow of removed fluid.

[0044] The controller can determine, prior to initiating or reinitiating provision of therapy, one or more characteristics of a wound dressing from the pressure in the fluid flow path. The one or more characteristics can include a size of the wound dressing, a type of the wound dressing, or whether the wound dressing includes a stabilizing structure. In one example, in response to determining that the wound dressing includes the stabilizing structure, the controller can determine to control application of negative pressure based on the measure of collapse, and in

response to determining that the wound dressing does not include the stabilizing structure, the controller can determine to control application of negative pressure instead to a pressure setpoint.

[0045] The controller can detect or characterize patient movement from pressure variations in the fluid flow path due to shifts in the stabilizing structure of a wound dressing. The patient movement can include, for instance, leg or arm movement or breathing by the patient (for example, when the stabilizing structure is placed in an abdominal wound).

[0046] The controller can determine whether a suture burst or failed from pressure variations in the fluid flow path. The suture may be used to hold together tissue near a wound dressing. In one example, the controller may monitor cycles of variations in pressure, such as in a peak-to-peak pressure signal, and detect a spike in pressure that may be indicative of a volume change of the wound due to a burst or failed suture.

Pressure Therapy Systems

[0047] Figure 1 illustrates an embodiment of a negative pressure treatment system 100 that comprises a wound packer 102 inserted into a wound 101. The wound packer 102 may comprise porous materials such as foam, and in some embodiments, may comprise one or more embodiments of wound closure devices described in further detail in this section or elsewhere in this specification. In some embodiments, the perimeter or top of any wound closure device inserted into the wound 101 may also be covered with foam or other porous materials. A single drape 104 or multiple drapes may be placed over the wound 101, and is preferably adhered or sealed to the skin on the periphery of the wound 101 so as to create a fluid-tight seal. An aperture 106 may be made through the drape 104 which can be manually made or preformed into the drape 104 so as to provide a fluidic connection from the wound 101 to a source of negative pressure such as a TNP apparatus 110 that includes a pump. Preferably, the fluidic connection between the aperture 106 and the pump of the TNP apparatus 110 is made via a conduit 108. In some embodiments, the conduit 108 may comprise a RENASYS® Soft Port™,

manufactured by Smith & Nephew. Of course, in some embodiments, the drape 104 may not necessarily comprise an aperture 106, and the fluidic connection to the pump of the TNP apparatus 110 may be made by placing the conduit 108 below the drape. In some wounds, particularly larger wounds, multiple conduits 108 may be used, fluidically connected via one or more apertures 106.

[0048] In some embodiments, the drape 104 may be provided with one or more corrugations or folds. Preferably, the corrugations are aligned along the longitudinal axis of the wound, and as such may support closure of the wound by preferentially collapsing in a direction perpendicular to the longitudinal axis of the wound. Such corrugations may aid in the application of contractile forces parallel to the wound surface and in the direction of wound closure. Examples of such drapes may be found in Application Serial No. 12/922,118, titled "Vacuum Closure Device," filed November 17, 2010 (published as US 2011/0054365), which is hereby incorporated by reference in its entirety.

[0049] In use, the wound 101 is prepared and cleaned. In some cases, such as abdominal wounds, a non- or minimally-adherent organ protection layer (not illustrated) may be applied over any exposed viscera. The wound packer 102 is then inserted into the wound, and is covered with the drape 104 so as to form a fluid-tight seal. A first end of the conduit 108 is then placed in fluidic communication with the wound, for example via the aperture 106. The second end of the conduit 108 is connected to the TNP apparatus 110. The pump of the TNP apparatus 110 may then be activated so as to supply negative pressure to the wound 101 and evacuate wound exudate from the wound 101. As will be described in additional detail below and in relation to the embodiments of the foregoing wound closure devices, negative pressure may also aid in promoting closure of the wound 101, for example by approximating opposing wound margins.

[0050] Any structure or component disclosed herein this section or elsewhere in the specification may comprise a radiopaque material. A radiopaque material advantageously allows a clinician to more easily find pieces of the wound closure device that may have come loose from the structure and become lost in the

wound. Some examples of radiopaque materials include barium sulfate, bismuth trioxide, bismuth subcarbonate, bismuth oxychloride, and tungsten.

[0051] Figure 2 illustrates a negative pressure therapy system 10A according to some embodiments. The system 10A includes a TNP apparatus 11 (which may be similar to the TNP apparatus 110 and the TNP apparatus of the Overview section) and a remote data processing system 13. The TNP apparatus 11 can be used to treat a wound using a wound dressing that is in fluidic communication with the TNP apparatus 11 via a fluid flow path. The TNP apparatus 11 can include a controller 12A (which may be similar to the controller of the Overview section), a memory device 12B, a negative pressure source 12C, a user interface 12D, a power supply 12E, a pressure sensor 12F, a transceiver 12G, and additional sensor(s) 12H that are configured to electrically communicate with one another. The TNP apparatus 11 can include a canister 12I that collects fluid including wound exudate. In some embodiments, wound exudate can additionally or alternatively be absorbed by a wound dressing and the canister 12I then may or may not be used.

[0052] The controller 12A can control operations of one or more other components of the TNP apparatus 11 according at least to instructions stored in the memory device 12B. The controller 12A can, for instance, control operations of and supply of negative pressure by the negative pressure source 12C. The negative pressure source 12C can include a pump, such as, without limitation, a rotary diaphragm pump or other diaphragm pump, a piezoelectric pump, a peristaltic pump, a piston pump, a rotary vane pump, a liquid ring pump, a scroll pump, a diaphragm pump operated by a piezoelectric transducer, a voice coil pump, or any other suitable pump or micropump or any combinations of the foregoing. The user interface 12D can include one or more elements that receive user inputs or provide user outputs to a patient or caregiver. The one or more elements that receive user inputs can include buttons, switches, dials, touch screens, microphones, or the like. The one or more elements that provide user outputs can include lights, displays, speakers, or the like.

[0053] The pressure sensor 12F can be used to monitor pressure underneath a wound dressing, such as by monitoring (i) pressure in a fluid flow path connecting the negative pressure source 12C and the wound dressing as illustrated by Figure 3, (ii) pressure at or in the wound dressing, or (iii) pressure at or in the negative pressure source 12C. In some implementations, the pressure sensor 12F can include at least two pressure sensors that are positioned in or fluidically connected to the fluid flow path to permit differential measurement of the pressure, such as differential measurement between pressure at or near the wound and pressure at or near the TNP apparatus 11. For example, a first pressure sensor can be positioned upstream of the wound (such as at or near the inlet of the negative pressure source 12C) and a second pressure sensor can be positioned to detect pressure at or near the wound or at or near a canister. This configuration can be accomplished by incorporating, in addition to one or more lumens forming a first fluid flow path connecting the negative pressure source 12C to the wound, a second fluid flow path that includes one or more lumens connecting the TNP apparatus 11 to the wound and through which the second pressure sensor can monitor pressure at or near the wound or at or near a canister. The first and second fluid flow paths can be fluidically isolated from each other.

[0054] Figure 3 illustrates a negative pressure therapy system 10B according to some embodiments. The system 10B includes the TNP apparatus 11, as well as a fluid flow path 15, a wound dressing 16, and a wound 17. The TNP apparatus 11 can be used to treat the wound 17 using the wound dressing 16 that is in fluidic communication with the negative pressure source 12C via the fluid flow path 15. The pressure sensor 12F is depicted in Figure 3 as being positioned in the fluid flow path 15, such as at or near an inlet of the TNP apparatus 11, to measure pressure in the fluid flow path 15. The wound dressing 16 can embody any of the wound dressings or wound closure devices described herein. In some implementations, the canister 12I may not be used and, instead, wound exudate can be collected by wound dressing 16 which can be absorbent. In other implementations, both the canister 12I and the wound dressing 16 can be used, and the wound dressing 16 can be absorbent.

[0055] Turning again to Figure 2, the transceiver 12G can be used to communicate with the data processing system 13 via a network 14. The transceiver 12G can, for example, transmit device usage data like alarms, rate of fluid removal, measured pressure, or changes to a therapy program administered by the TNP apparatus 11 to the data processing system 13. The network 14 can be a communication network, such as a wireless communication network like a cellular communication network or a wired communication network. The memory device 12B can be used to store the device usage data that may then be transmitted by the transceiver 12G. The data processing system 13 can, in some implementations, automatically store data received from the transceiver 12G to an electronic medical file associated with a patient that used or is prescribed to use the TNP apparatus 11. The transceiver 12G can, in some instances, include a transmitter to transmit data separate from a receiver used to receive data.

[0056] The additional sensor(s) 12H can include, for example, a level sensor that detects a level of fluid in the canister 12I or a scale that weighs one or more components of the negative pressure therapy systems 10A and 10B like the canister 12I or the wound dressing 16. The controller 12A can use the additional sensor(s) 12H to monitor a rate of fluid removal from a wound, such as the wound 17.

Pressure Therapy Methods

[0057] Figure 4A illustrates a fluid removal management process 20 performable by a device, such as the controller 12A of the TNP apparatus 11 or a controller of the TNP apparatus 110. For convenience, the fluid removal management process 20 is described in the context of the TNP apparatus 11 of Figures 2 and 3, but may instead be implemented in other systems described herein or by other computing systems not shown. The fluid removal management process 20 can advantageously, in certain embodiments, enable the TNP apparatus 11 to monitor a rate of fluid removal from the wound 17 and automatically wirelessly communicate the rate of fluid removal to another device and output an indication when the rate of fluid removal becomes excessive.

[0058] At block 21, the fluid removal management process 20 can monitor a rate of fluid removal from the wound 17. For example, the fluid removal management process 20 can use measurements provided by one or more sensors, like the pressure sensor 12F or the additional sensor(s) 12H, to monitor the rate of fluid removal.

[0059] At block 22, the fluid removal management process 20 can wirelessly communicate the rate of fluid removal to the data processing system 13. The fluid removal management process 20 can, for instance, use the transceiver 12G to communicate the rate of fluid removal via the network 14 to the data processing system 13. The fluid removal management process 20 can communicate over a wired interface rather than or in addition to wirelessly in some implementations.

[0060] At block 23, the fluid removal management process 20 can determine whether the rate of fluid removal meets a threshold. The thresholds can be a rate threshold whose magnitude indicates an excessive fluid rate increase or decrease during delivery of negative pressure therapy with the TNP apparatus 11.

[0061] When the rate of fluid removal meets the threshold, at block 24, the fluid removal management process 20 can output an indication that the rate of fluid removal experienced an excessive fluid rate increase or decrease during delivery of negative pressure therapy with the TNP apparatus 11. The indication can, for instance, include activation a visible or audible alarm of the user interface 12D or display of a textual warning message on a display of the user interface 12D.

[0062] On the other hand, when the rate of fluid removal does not meet the threshold, the fluid removal management process 20 can end.

[0063] Figure 4B illustrates a collapse monitoring process 30 performable by a device, such as the controller 12A of the TNP apparatus 11 or a controller of the TNP apparatus 110. For convenience, the collapse monitoring process 30 is described in the context of the TNP apparatus 11 of Figures 2 and 3, but may instead be implemented in other systems described herein or by other computing systems not shown. The collapse monitoring process 30 can advantageously, in certain embodiments, enable the TNP apparatus 11 to monitor collapse of a

stabilizing structure of the wound dressing 16 placed in the wound 17 from pressure in the fluid flow path 15 and appropriately control operation of the TNP apparatus 11.

[0064] At block 31, the collapse monitoring process 30 can monitor pressure in a fluid flow path. For example, the controller 12A can monitor pressure using the pressure sensor 12F or the additional sensor(s) 12H positioned to detect the pressure in the fluid flow path 15.

[0065] At block 32, the collapse monitoring process 30 can determine a measure of collapse of a stabilizing structure of a wound dressing. For example, the controller 12A can determine a measure of collapse of a stabilizing structure of the wound dressing 16 from the pressure in the fluid flow path 15 detected by the pressure sensor 12F or the additional sensor(s) 12H. The measure of collapse can, for instance, be determined from a change in a magnitude or a frequency of the pressure in the fluid flow path over time as described herein. In one example, the controller can compare the magnitude over time to one or more pressure patterns indicative of one of (i) pressure magnitude in the fluid flow path when the stabilizing structure is fully collapsed, (ii) pressure magnitude in the fluid flow path when the stabilizing structure is partially collapsed, and (iii) pressure magnitude in the fluid flow path when the stabilizing structure is not collapsed, and the controller can determine the measure of collapse from a degree of similarity of the magnitude over time to the one or more of the pressure patterns. In another example, the measure of collapse can be or be related to a degree or a rate of collapse of the stabilizing structure.

[0066] At block 33, the collapse monitoring process 30 can output an indication responsive to the measure of collapse. For example, the controller 12A can output an indication according to the measure of collapse. The collapse monitoring process 30 can, in some implementations, output the indication to control activation and deactivation of the negative pressure source for a time period (such as for 1 minutes, 5 minutes, 10 minutes, 30 minutes, 1 hour, or 5 hours) according to the measure of collapse rather than to control activation and deactivation of the negative pressure source to adjust the magnitude of pressure to target a predetermined negative pressure threshold. In some implementations, the controller

can output the indication for presentation to a user (such as via a visible, audible, or tactile alarm of the user interface 12D or display of a textual warning message on a display of the user interface 12D) or for storage in a memory device, such as for storage in association with device usage data like a pressure level, an alarm, an exudate level, an event log, and an operation use time. In some embodiments, at block 33, the collapse monitoring process 30 can adjust one or more parameters of negative pressure therapy, such as the negative pressure level, mode (for example, continuous or intermittent), etc. Control of negative pressure therapy can be tied to achieving or maintaining a target level of collapse of the stabilizing structure (for example, 10% when the treatment has begun, 30% after treatment has been applied for some time, etc.). Additionally or alternatively, the collapse monitoring process 30 can activate or deactivate the negative pressure source, increase or decrease a target negative pressure provided by the negative pressure source, or release negative pressure in the fluid flow path.

Fluid Detection

[0067] Presence of exudate in the fluid flow path can be detected by processing data from one or more pressure sensors, such as the pressure sensor 12F. This detection can be enhanced by changing one or more settings of the negative pressure source, such as increasing the delivered vacuum level, decreasing the vacuum level, pausing or stopping the negative pressure source, changing the speed of an actuator (such as a pump motor), changing a cadence of the actuator, and the like. In some embodiments, as the negative pressure source operates, it generates pressure pulses or signals that are propagated through the fluid flow path. The pressure signals are illustrated in the pressure curve 402 of Figure 5 according to some embodiments. As is illustrated in region 404, pressure in the fluid flow path varies or oscillates around a particular pressure setting or set point 408 (for example, as selected by the user) during normal operation of the system. Region 406 illustrates pressure pulses in the flow path when there is a blockage distal to the negative pressure source, such as the canister (or dressing) becomes full or a canister filter is occluded or blocked. As is illustrated, a distal

blockage causes a reduced volume to be seen upstream of the canister (or dressing), and the amplitude of the pressure pulses increases. The frequency of a pressure signal is slowed or decreased in some embodiments. In certain embodiments, this change or “bounce” in the magnitude (or frequency) of the pressure pulse signal can be magnified or enhanced by varying the speed of the actuator, varying the cadence of the actuator, such as by adjusting pulse-width modulation (PWM) control parameters, and the like. Such adjustments of negative pressure source operation are not required but can be performed over short time duration and the changes can be small such that the operation of the system remains relatively unaffected. In some embodiments, the canister filter can be hydrophobic so that the flow of liquid is substantially blocked while the flow of air is allowed. Additional details of flow rate detection are described in U.S. Patent No. 8,843,327, which is incorporated by reference in its entirety.

[0068] Canisterless systems can use an absorbent dressing for exudate removed from the wound. Such dressing may include absorbing or superabsorbing material to collect or retain exudate so that it is not aspirated into the negative pressure source. Similar to a canister filter, a dressing filter (which may be hydrophobic) may be used to prevent the exudate from reaching the negative pressure source. In such systems, detection of a dressing full condition or dressing filter (which may be) occluded condition can be an equivalent to detection of a canister full condition.

[0069] Changes in characteristics of pressure signals can be used to determine collapse of stabilizing structures, rate of fluid removal, distal blockages, level of exudate in the canister (or dressing), canister (or dressing) full conditions, and the like. The characteristics can include signal magnitude, frequency, shape (e.g., envelope), etc. In some embodiments, the system can detect the rate of fluid removal by monitoring the change in the magnitude of pressure pulses over time. For example, as the canister (or dressing) becomes filled with wound exudate, the magnitude of pressure pulses can increase, as illustrated in region 406. Additional details of monitoring the rate of fluid removal are disclosed in U.S. Patent Publication No. 2016/0184496, which is incorporated by reference in its entirety.

Stabilizing Structures and Wound Closure Devices

[0070] Figure 6A is a drawing of an embodiment of a stabilizing structure 6000 comprising a plurality of elongate strips 6006 arranged in parallel or semi-parallel, whose longitudinal length can be aligned with the longitudinal axis of a wound. In embodiments, the elongate strips 6006 may also be arranged in a non-parallel fashion. The various cells within this stabilizing structure 6000 may have a variety of shapes and sizes. As will be described in greater detail below, the length and shape of the elongate strips 6006, intervening members 6010, and cells 6004 may be designed so as to facilitate greater closure of the stabilizing structure. In certain embodiments, the junctions 6900 between the elongate strips and intervening members may be thinned to better facilitate rotation and closure of the stabilizing structures. In some embodiments, the stabilizing structure is tearable, such that the structure may be shaped into the shape of a wound. As described elsewhere in the specification, tears may be completed at the intersections between intervening members and elongate strips or at any suitable location along the elongate strip or intervening member.

[0071] All stabilizing structures described herein this section or elsewhere in the specification may be fashioned to accommodate any size of wound. However, to better accommodate the needs of the clinical environment, in certain embodiments, the stabilizing structures described herein may be provided in a pack of two sizes, one smaller stabilizing structure and one larger stabilizing structure about 1.25 times as larger, about 1.5 times as large, about 1.75 times as large, about 2 times as larger, about 2.5 times as larger, about 3 times as large, about 4 times as large, about 5 times as large, or more than about 5 times as large. In some embodiments, the pack may comprise more than two sizes, such as three sizes, four sizes, five sizes, or more than five sizes. The stabilizing structures within the pack may be of a variety of sizes in relation to one another such as the ratios described above.

[0072] In certain embodiments, the stabilizing structure 6000 can collapse in any manner described in this section or elsewhere in this specification with or

without the application of negative pressure. For example, the stabilizing structure may collapse significantly more in one plane than in another plane upon application of negative pressure. In some embodiments, the stabilizing structure is configured to collapse more in a horizontal plane parallel to the length and width of the stabilizing structure than in a vertical plane perpendicular to the horizontal plane. In embodiments, particular rows may collapse in a first direction, while another row may collapse in the same or an opposing direction. In certain embodiments, the stabilizing structure may collapse along the width of the stabilizing structure while remaining relatively rigid along the length of the stabilizing structure and in the vertical direction.

[0073] The stabilizing structure may be comprised of any materials described in this section or elsewhere in this specification, including: flexible plastics such as silicone, polyurethane, rigid plastics such as polyvinyl chloride, semi-rigid plastics, semi-flexible plastics, biocompatible materials, composite materials, metals, and foam. In certain embodiments, the stabilizing structure may comprise a radio opaque material, to more readily allow a clinician to find pieces of the stabilizing structure within the wound.

[0074] Returning to Figure 6A, stabilizing structure 6000 may have an outer perimeter that defines an at least partially elliptical shape. As described above, stabilizing structure 6000 may comprise a plurality of cells 6004 provided side-by-side, each cell defined by one or more walls, each cell having a top end and a bottom end with an opening extending through the top and bottom ends. As with the other stabilizing structures described herein this section and elsewhere in the specification, the stabilizing structure 6000 is configured to collapse by collapsing one or more cells 6004. In some embodiments, the cells are all of the same approximate shape and size; however, in other embodiments, the cells are of different shapes and sizes. In some embodiments, the stabilizing structures as described herein this section or elsewhere in the specification may be domed, such that the central portion of the stabilizing structure bulges upward. For example, a lower portion of the stabilizing structure may be concave, while an upper portion of the stabilizing structure is convex.

[0075] The elongate strips 6006 may be made from one single material, such as those described elsewhere in the specification, or the elongate strips may be made from multiple materials. For example, elongate strips 6006 may comprise sections of more rigid material and sections of more flexible material. The elongate strips 6006 may be curved along their length so as to facilitate the curved outer perimeter of the stabilizing structure 6000. The elongate strips may be curved along their lengths outward away from a center of the stabilizing structure 6000. The arch of the curves of the elongate strips 6006 may vary considerably, with some strips 6006 being highly curved while other are minimally curved or even straight.

[0076] Similarly, the stabilizing structure 6000 can further comprise a plurality of intervening members 6010 connected to the elongate strips 6006. The intervening members 6010 may all be of a similar shape and size or they may be of a variety of shapes and sizes. The intervening members may be constructed from any material disclosed herein this section or elsewhere in the specification. Further, the intervening members may be constructed from multiple materials.

[0077] Advantageously, the elliptical shape of stabilizing structure 6000 may allow the structure to better accommodate the shape of the wound. Most wounds are in shapes that are rounded, thus, an elliptically shaped stabilizing structure 6000 may better fit into a wound.

[0078] In embodiments, the outer perimeter 6002 may have a reduced edge 6012 so as to facilitate collapse of the stabilizing structure. By removing mass of the stabilizing structure at reduced edge 6012, the stabilizing structure can collapse more freely at reduced edge 6012, thus allowing for a better fit within the wound. Further, by reduced the mass at reduced edge 6012, there may be less pinching of the surrounding tissue during and after collapse of the stabilizing structure 6000.

[0079] The stabilizing structure 6000 and all stabilizing structures and wound closure devices described in this section or elsewhere in this specification can collapse on a variety of timescales in a dynamic fashion. In certain embodiments, the majority of the collapse may occur within the first few minutes upon application of negative pressure. However, after the initial collapse, the

stabilizing structure or wound closure device may continue to collapse at a much slower rate, thereby applying increasing longitudinal tension over a long period of time and drawing the edges of the wound closer together. By slowly drawing the wound edges closer together over time, the stabilizing structure or wound closure device allows the surrounding healing tissue to remodel synergistically with the closure of the device or stabilizing structure. Slow, dynamic wound closure may allow the surrounding tissue to heal at an accelerated rate, because the collapsing structure or device slowly brings the edges of the wound closer together without stressing the newly formed or weakened tissue too quickly.

[0080] In some embodiments, the stabilizing structures described in this section or elsewhere in this specification can be placed into a wound for a period of time and then removed or replaced with another stabilizing structure. For example, a stabilizing structure could be inserted into a wound for a period of time, promoting closure of the wound by drawing the edges closer together. After a period of time has passed, the stabilizing structure can be replaced by a stabilizing structure of a different size or collapsibility, for example a stabilizing structure of a smaller size or decreased density. This process could be repeated over and over, thereby continuously drawing the edges of the wound together over time and allowing for continuing repair and remodeling of the surrounding tissue. In certain embodiments, the stabilizing structure is configured to remain in the wound for at least about less than 1 hour, at least about 1 hour, at least about 2 hours, at least about 4 hours, at least about 6 hours, at least about 8 hours, at least about 12 hours, at least about 24 hours, at least about 2 days, at least about 4 days, at least about 6 days, at least about 1 week, at least about 2 weeks, at least about 3 weeks, or more than 3 weeks.

[0081] In certain embodiments, up to 90% of the collapse of the stabilizing structure or wound closure device may occur within the first few minutes upon application of negative pressure, while the remaining 10% of the collapse may occur slowly over a period of many minutes, hours, days, weeks, or months. In other embodiments, up to about 80% of the collapse, up to about 70%, up to about 60%, up to about 50%, up to about 40%, up to about 30%, up to about 20%, up to about 10%, or about 0% of the collapse will occur immediately within the first few minutes

upon application of negative pressure while the remainder of the collapse occurs at a much slower rate such as over the course of many minutes, hours, days weeks, or months. In other embodiments, the stabilizing structure can collapse at a variable rate. In some embodiments, the entirety of the collapse occurs at a slowed rate, while in other embodiments the entirety of the collapse occurs almost immediately within the first few minutes. In further embodiments, the collapse can occur at any rate and the rate can vary over time. In certain embodiments, the rate of collapse can be altered in a variable fashion by adding or removing portions of the structure or by controlling the application of negative pressure and irrigant fluid.

[0082] Returning to Figure 6A, in some embodiments, the pattern of the stabilizing structure 6000 is designed in such a way as to facilitate maximum closure of the stabilizing structure. Preferably, maximum closure is in a direction perpendicular to the length of the elongate members and within the horizontal plane. As will be described in greater detail below, greater closure may be achieved by varying the length of the elongate strips 6006, the length of the intervening members 6010, and the shape of the cells 6004. The shape of the cells 6004 may comprise any shape described herein this section or elsewhere in the specification. For example, as depicted in Figure 6A, the cells 6004 may be diamond-shaped or parallelepiped with smaller diamond-like shapes 6020 located within larger diamonds 6022. Such a construction may provide greater overall closure of the stabilizing device 6000 to provide for maximum closure of the wound. Additionally, the smaller diamond-like shapes 6020 located within larger diamonds 6022 can spread the load over a greater area reducing the chance of damage to the tissue structures below the matrix. This construction can also reduce the likelihood of the foam or the drape being pulled into the matrix and preventing closure of the wound.

[0083] Figures 6B-C are illustrations of different views of the stabilizing structure embodiment of Figure 6A. As described above in relation to Figure 6A, the stabilizing structure comprises cells 6004, intervening members 6010, and elongate strips 6006; however, here a simulated shape of a wound 6910 is also included for comparison.

[0084] Any of the stabilizing structures described herein this section or elsewhere in the specification may be constructed from any suitable means. For example, the stabilizing structures may be constructed via molding or may be printed directly using 3D printing technology. In certain embodiments, the stabilizing structures of Figures 6A-C may be constructed from a single polymer via 3D printing. In some embodiments, the stabilizing structures may be constructed from one polymer, two polymers, three polymers, or more than three polymers. The stabilizing structures may be constructed from any material disclosed herein this section or elsewhere in the specification. The stabilizing structure can be made by cutting the structure out of a solid block of material. Methods used for cutting can include, for example, water jet cutting, laser cutting, or die cutting. The stabilizing structures may be cut to size along the walls of the cells 6004. For example, the intervening members along the outside face of elongate strips 6006 can be cut off to appropriately size the stabilizing structure. The stabilizing structure may be cut along the walls, along any portions of the elongate strips, or along any portions of the intervening members.

[0085] In some embodiments, the stabilizing structure 6000 of Figures 6A-C can be configured to include perforations or detachable sections that allow portions of the device to separate from the remainder of the device. For example, perforations may be incorporated into the joints 6900 between various cells 6004 contained within the stabilizing structure 6000, allowing for the removal of individual rows or cells to alter the shape of the stabilizing structure 6000.

[0086] Applicable to all stabilizing structures or wound closure devices described in this section or elsewhere in the specification, the stabilizing structure or wound closure device may be tearable such that the stabilizing structure may be shaped into the shape of a wound. In some embodiments, the stabilizing structure may be torn at the intersections between intervening members and elongate strips, while in further embodiments, the elongate strips or intervening members may be torn at any suitable position.

Wound Closure and Treatment Methods

[0087] The stabilizing structures or wound closure devices described in this section or elsewhere in this specification may be used in conjunction with methods or systems for the closure of a wound. In some embodiments of methods of use for closure of a wound, one or more of the stabilizing structures or wound closure devices of any of the embodiments described in this section or elsewhere in this specification is placed into a wound. In some embodiments, an organ protection layer may be provided in the wound before placement of the stabilizing structure. In certain embodiments, foam or other porous material may be placed in the wound along with the stabilizing structure or wound closure device, either below, above, or surrounding the stabilizing structure or wound closure device. Foam or other porous material may also surround the perimeter of the stabilizing structure or wound closure device. The stabilizing structure or wound closure device may be configured to collapse in any manner as described in this section or elsewhere in this specification, for example by having a particular size and shape, or by comprising a certain volume of foam or other porous material within the cells of the structure. The stabilizing structure or wound closure device may further be altered in any manner described in this section or elsewhere in this specification so as to better accommodate the shape of the wound. After placement in the wound, the stabilizing structure or wound closure device can be sealed by a fluid-tight drape. The fluid-tight drape can comprise a port configured for the application of negative pressure. A source of negative pressure may then be connected to the port and negative pressure may be applied to the wound. The stabilizing structure or wound closure device may be replaced over time by stabilizing structures or wound closure devices of various shapes and sizes as desired to best promote wound healing.

[0088] Figures 7-15E depict embodiments of methods for the treatment of a wound that utilize a wound closure device comprising a stabilizing structure as described herein this section and elsewhere in the specification. To better illustrate non-limiting embodiments of the methods, numbers have been added to the steps of Figure 13 to allow the reader to more easily follow these steps of the method. However, the steps can be performed in any order, and any numbering system is for

clarity only. Further, in some embodiments, different steps of these methods may be excluded. In other embodiments, additional steps may be added to the methods based on methods described herein this section and elsewhere in the specification. The porous layers and structures described in this section may be of any material or structure described elsewhere in the specification, such as foam.

[0089] Figure 7 depicts an embodiment of an open wound 5100 prior to treatment with a wound closure device as will be described in much greater detail below. The open wound of Figure 7 is similar to the wounds described elsewhere in the specification, particularly as relate to Figure 1. In some instances, as described elsewhere in the specification, such a wound may be produced via a surgical incision or other means.

[0090] Figure 8 depicts an embodiment of an initial step in a method for the treatment of an open wound 5100 with a wound closure device. Before treatment, the wound may be cleaned with a pad 5180 and the skin 5190 prepared for application of a wound closure device, such as those described in relation to Figures 6A-C.

[0091] Figure 9 depicts an embodiment of an early step in a method for the treatment of an open wound 5100. In some embodiments, a tissue protection layer 5170 may be placed over the wound to protect the underlying tissues from the rigors of negative pressure wound therapy or other potential harms. Accordingly, certain embodiments provide for a tissue protection layer 5170 which may be cut to size to be placed over the wound site 5100. The tissue protection layer 5170 can be a material which will not adhere to the wound site or to the exposed viscera in close proximity. Such a tissue protection layer may be constructed from any suitable material such as a biocompatible polymer. For example, organ protection layers manufactured by Smith & Nephew and sold under the brand RENASYS® may act as tissue protection layers and be placed over the abdominal cavity or wound bed 5100 and tucked over the peritoneal gutter. In further examples, materials such as the fluoropolymer polytetrafluoroethylene (PTFE) may be applicable as these materials are generally non-adherent and used in surgical grafts. In one embodiment, the tissue protection layer is permeable. For example, the tissue protection layer 5170

can be provided with openings, such as holes, slits, or channels, to allow the removal of fluids from the wound site 5100 or the transmittal of negative pressure to the wound site 5100. In further embodiments, the tissue protection layer may be used over non-abdominal wounds on other areas of the body, such as the leg, arm, shoulder, or back. In certain embodiments, the tissue protection layer may comprise a sensor configured to measure pressures in and around the wound. For example, the sensor may be used to measure the level of negative pressure applied to the wound or to measure the pressure on the underlying organs beneath the abdominal wound.

[0092] Figures 10A-C illustrate embodiments of possible initial steps in a method for the treatment of an open wound. However, as described above, the steps need not be performed in this order and may be performed in any order. In Figure 10A, two pieces of a porous material such as foam, a bottom piece 5102 and a top piece 5116 are selected so as to approximate the size of the wound 5100. In some embodiments, the top piece and the bottom piece are of identical thickness. However, in certain embodiments, and vice-versa, top piece 5116 may be at least twice as thick, at least four times as thick, at least 10 times as thick or more than ten times as thick as bottom piece 5102. Figure 10B illustrates an embodiment of additional steps in a method for the treatment of an open wound. Bottom piece 5102 may be shaped via cutting or other suitable means to the shape of the wound and subsequently placed into the wound 5100, as shown in Figure 10C and depicted further below in Figure 11A.

[0093] Figures 11A-B depict a foam layer 5102 (for example, a 15 mm layer of foam), after shaping, placed into a wound bed 5100. In Figures 12A-C, a stabilizing structure 5104 similar to the stabilizing structures disclosed in Figures 6A-C or any other stabilizing structure described elsewhere in the specification, is in the shape of the wound. The stabilizing structure may be shaped into the shape of the wound via cutting or other suitable means or the stabilizing structure may initially be of a size that is readily accommodated by the wound. As displayed in Figure 12B, the stabilizing structure 5104 may be placed into the wound. To assist with the insertion of the device into the wound bed, the device can be deformed slightly

inwardly or horizontally to facilitate entrance into the wound site. In some embodiments, the device may be squeezed slightly during insertion and then release upon contact with the walls of the wound. In certain embodiments, the wound closure device 5104 may be placed such that the longitudinal sides of the matrix align with the longitudinal axis of the wound 5100. Continuing with Figure 12B, another foam layer 5116 (for example, a 10 mm layer of foam) is placed on top of the wound closure device 5104.

[0094] Figure 12C is illustrate application of a port 5122 to the stabilizing structure and foam of Figures 12A-B. A bridging portion of foam 5118 may be placed in intimate contact with the foam layer 5116 at the edge of the wound. The bridging portion of foam 5118 may extend over intact skin, with a piece of drape 5120 placed between it and the intact skin. Further, a suction port 5122 may be connected to the bridging portion 5118 with a section of drape 5120 between. In alternative embodiments, the bridging portion 5118 and suction port 5122 may be placed on the wound during a different step depicted in Figures 11A-12B.

[0095] In Figure 13, as shown by steps 1-4, the device may be covered by one or more drapes 5120. A hole may be made in the drape covering the bridging portion of foam, and a suction port 5122 may be placed over the hole. A protective layer 5124 on the top surface of the one or more drapes may be removed after the drapes 5120 are applied. Once the drapes 5120 are applied and the port is in place, negative pressure may be applied to the wound through the drape from a vacuum source. The negative pressure can cause the stabilizing structure to collapse horizontally as described elsewhere in this specification. The tissue anchors adhered to the stabilizing structure through the porous layer engage tissue of the wound and may facilitate closure of the wound.

[0096] Figures 14A-C provide further illustrations of an upper foam layer 5116 being placed in a wound, followed by placing a bridging portion 5118 and placing one or more drapes or wound covers 5120. Figures 14D-G illustrate an embodiment of several steps in a method for the treatment and closure of a wound. As illustrated in Figure 14D, a suction port 5122 is separated from a release liner 5126 and later applied to a wound as depicted in Figures 11A-13. Figure 14E

illustrates a canister 5128 being inserted into a negative pressure wound therapy device 5130 in preparation for the collection of wound exudate. Figure 14F illustrates the snap connection between the tubing connected to the suction port and the tubing connected to the negative pressure wound therapy device 5130. Once the connection has been made, negative pressure wound treatment may begin as depicted in Figure 14G.

[0097] Figures 15A-E illustrate an alternative method for closing a wound, with some similarities to the methods of Figures 7-14G. Here, foam is placed under the muscle and fascia, followed by foam extending vertically out of the wound and folded over. Such a method may provide enhanced closure of the dermis but possibly not at the fascia level. In alternative embodiments, such a configuration may be combined with a stabilizing structure such as those disclosed herein this section and elsewhere in the specification, by providing a folded over foam layer 5116 that bulges out of the wound. Figure 15E is a cross-sectional drawing of the alternative method.

[0098] Further details regarding the wound closure devices, stabilizing structures, related apparatuses and methods of use that may be combined with or incorporated into any of the embodiments described herein are found elsewhere throughout this specification and in International Application No. PCT/US2013/050698, filed July 16, 2013, published as WO 2014/014922 A1, the entirety of which is hereby incorporated by reference.

Other Variations

[0099] Any value of a threshold, limit, duration, etc. provided herein is not intended to be absolute and, thereby, can be approximate. In addition, any threshold, limit, duration, etc. provided herein can be fixed or varied either automatically or by a user. Furthermore, as is used herein relative terminology such as exceeds, greater than, less than, etc. in relation to a reference value is intended to also encompass being equal to the reference value. For example, exceeding a reference value that is positive can encompass being equal to or greater than the reference value. In addition, as is used herein relative terminology such as exceeds,

greater than, less than, etc. in relation to a reference value is intended to also encompass an inverse of the disclosed relationship, such as below, less than, greater than, etc. in relations to the reference value. Moreover, although blocks of the various processes may be described in terms of determining whether a value meets or does not meet a particular threshold, the blocks can be similarly understood, for example, in terms of a value (i) being below or above a threshold or (ii) satisfying or not satisfying a threshold.

[0100] Features, materials, characteristics, or groups described in conjunction with a particular aspect, embodiment, or example are to be understood to be applicable to any other aspect, embodiment or example described herein unless incompatible therewith. All of the features disclosed in this specification (including any accompanying claims, abstract and drawings), or all of the steps of any method or process so disclosed, may be combined in any combination, except combinations where at least some of such features or steps are mutually exclusive. The protection is not restricted to the details of any foregoing embodiments. The protection extends to any novel one, or any novel combination, of the features disclosed in this specification (including any accompanying claims, abstract and drawings), or to any novel one, or any novel combination, of the steps of any method or process so disclosed.

[0101] While certain embodiments have been described, these embodiments have been presented by way of example only, and are not intended to limit the scope of protection. Indeed, the novel methods and systems described herein may be embodied in a variety of other forms. Furthermore, various omissions, substitutions and changes in the form of the methods and systems described herein may be made. Those skilled in the art will appreciate that in some embodiments, the actual steps taken in the processes illustrated or disclosed may differ from those shown in the figures. Depending on the embodiment, certain of the steps described above may be removed, others may be added. For example, the actual steps or order of steps taken in the disclosed processes may differ from those shown in the figure. Depending on the embodiment, certain of the steps described above may be removed, others may be added. For instance, the various components illustrated in

the figures may be implemented as software or firmware on a processor, controller, ASIC, FPGA, or dedicated hardware. Hardware components, such as processors, ASICs, FPGAs, and the like, can include logic circuitry. Furthermore, the features and attributes of the specific embodiments disclosed above may be combined in different ways to form additional embodiments, all of which fall within the scope of the present disclosure.

[0102] User interface screens illustrated and described herein can include additional or alternative components. These components can include menus, lists, buttons, text boxes, labels, radio buttons, scroll bars, sliders, checkboxes, combo boxes, status bars, dialog boxes, windows, and the like. User interface screens can include additional or alternative information. Components can be arranged, grouped, displayed in any suitable order.

[0103] Although the present disclosure includes certain embodiments, examples and applications, it will be understood by those skilled in the art that the present disclosure extends beyond the specifically disclosed embodiments to other alternative embodiments or uses and obvious modifications and equivalents thereof, including embodiments which do not provide all of the features and advantages set forth herein. Accordingly, the scope of the present disclosure is not intended to be limited by the specific disclosures of preferred embodiments herein, and may be defined by claims as presented herein or as presented in the future.

[0104] Conditional language, such as “can,” “could,” “might,” or “may,” unless specifically stated otherwise, or otherwise understood within the context as used, is generally intended to convey that certain embodiments include, while other embodiments do not include, certain features, elements, or steps. Thus, such conditional language is not generally intended to imply that features, elements, or steps are in any way required for one or more embodiments or that one or more embodiments necessarily include logic for deciding, with or without user input or prompting, whether these features, elements, or steps are included or are to be performed in any particular embodiment. The terms “comprising,” “including,” “having,” and the like are synonymous and are used inclusively, in an open-ended fashion, and do not exclude additional elements, features, acts, operations, and so

forth. Also, the term “or” is used in its inclusive sense (and not in its exclusive sense) so that when used, for example, to connect a list of elements, the term “or” means one, some, or all of the elements in the list. Further, the term “each,” as used herein, in addition to having its ordinary meaning, can mean any subset of a set of elements to which the term “each” is applied.

[0105] Conjunctive language such as the phrase “at least one of X, Y, and Z,” unless specifically stated otherwise, is otherwise understood with the context as used in general to convey that an item, term, etc. may be either X, Y, or Z. Thus, such conjunctive language is not generally intended to imply that certain embodiments require the presence of at least one of X, at least one of Y, and at least one of Z.

[0106] Language of degree used herein, such as the terms “approximately,” “about,” “generally,” and “substantially” as used herein represent a value, amount, or characteristic close to the stated value, amount, or characteristic that still performs a desired function or achieves a desired result. For example, the terms “approximately,” “about,” “generally,” and “substantially” may refer to an amount that is within less than 10% of, within less than 5% of, within less than 1% of, within less than 0.1% of, and within less than 0.01% of the stated amount. As another example, in certain embodiments, the terms “generally parallel” and “substantially parallel” refer to a value, amount, or characteristic that departs from exactly parallel by less than or equal to 15 degrees, 10 degrees, 5 degrees, 3 degrees, 1 degree, or 0.1 degree.

[0107] The scope of the present disclosure is not intended to be limited by the specific disclosures of preferred embodiments in this section or elsewhere in this specification, and may be defined by claims as presented in this section or elsewhere in this specification or as presented in the future. The language of the claims is to be interpreted broadly based on the language employed in the claims and not limited to the examples described in the present specification or during the prosecution of the application, which examples are to be construed as non-exclusive.

[0108] It is to be understood that, if any prior art publication is referred to herein, such reference does not constitute an admission that the publication forms a part of the common general knowledge in the art, in Australia or any other country.

[0109] In the claims which follow and in the preceding description of the invention, except where the context requires otherwise due to express language or necessary implication, the word “comprise” or variations such as “comprises” or “comprising” is used in an inclusive sense, i.e. to specify the presence of the stated features but not to preclude the presence or addition of further features in various embodiments of the invention.

WHAT IS CLAIMED IS:

1. A wound therapy apparatus comprising:
 - a negative pressure source configured to provide negative pressure via a fluid flow path to a wound dressing comprising a stabilizing structure, the stabilizing structure being configured to be inserted into a wound and collapse upon application of negative pressure to the wound when the stabilizing structure is positioned in the wound;
 - a sensor configured to detect pressure in the fluid flow path; and
 - a controller configured to:
 - determine a measure of collapse of the stabilizing structure from the pressure in the fluid flow path while the negative pressure source maintains a magnitude of the pressure in the fluid flow path within a negative pressure range; and
 - output an indication responsive to the measure of collapse.
2. The wound therapy apparatus of claim 1, wherein the controller is configured to determine the measure of collapse from a change in the magnitude of the pressure in the fluid flow path over time.
3. The wound therapy apparatus of claim 1 or claim 2, wherein the controller is further configured to determine the measure of collapse from a comparison of the magnitude of the pressure in the fluid flow path over time to a pressure change pattern.
4. The wound therapy apparatus of claim 3, wherein the pressure change pattern is indicative of one or more of: (i) pressure magnitude in the fluid flow path when the stabilizing structure is fully collapsed, (ii) pressure magnitude in the fluid flow path when the stabilizing structure is partially collapsed, or (iii) pressure magnitude in the fluid flow path when the stabilizing structure is not collapsed.

5. The wound therapy apparatus of any one of claims 1-4, wherein the measure of collapse comprises a rate of collapse of the stabilizing structure.

6. The wound therapy apparatus of any one of claims 1-5, wherein the controller is further configured to detect that a suture burst or failed from the pressure in the fluid flow path, the suture being proximate to the wound dressing.

7. The wound therapy apparatus of any one of claims 1-6, wherein the controller is configured to output the indication to (i) activate or deactivate the negative pressure source, (ii) activate or deactivate an alarm, (iii) increase or decrease a target negative pressure provided by the negative pressure source, or (iv) release negative pressure in the fluid flow path.

8. The wound therapy apparatus of any one of claims 1-7, wherein the controller is configured to output the indication to control activation and deactivation of the negative pressure source for a time period according to a target level of collapse of the stabilizing structure rather than to control activation and deactivation of the negative pressure source to adjust the magnitude of the pressure in the fluid flow path to target a predetermined negative pressure threshold.

9. The wound therapy apparatus of claim 8, wherein the time period is at least 1 minute.

10. The wound therapy apparatus of any one of claims 1-9, wherein the controller is configured to output the indication for presentation to a user or storage in a memory device.

11. The wound therapy apparatus of any one of claims 1-10, wherein the controller is further configured to store, in a memory device, device usage data in association with the indication, and the device usage data comprises one or more of a pressure level, an alarm, an exudate level, an event log, and an operation use time.

12. The wound therapy apparatus of any one of claims 1-11, wherein the controller is further configured to determine whether the wound dressing comprises the stabilizing structure from the pressure in the fluid flow path.

13. The wound therapy apparatus of any one of claims 1-12, wherein the sensor is configured to detect the pressure in the fluid flow path at the wound dressing, in one or more lumens of the fluid flow path, or at an inlet of the negative pressure source.

14. The wound therapy apparatus of any one of claims 1-13, wherein the negative pressure source is configured to perform negative pressure therapy when the magnitude of the pressure in the fluid flow path is maintained within the negative pressure range.

15. A method of operating a wound therapy apparatus comprising a controller and a negative pressure source configured to provide negative pressure via a fluid flow path to a wound dressing, the wound dressing comprising a stabilizing structure, the stabilizing structure configured to be inserted into a wound and further configured to collapse upon application of negative pressure to the wound when the stabilizing structure is positioned in the wound, the method comprising:

monitoring pressure in the fluid flow path;

determining a measure of collapse of the stabilizing structure from the pressure in the fluid flow path while the negative pressure source maintains a magnitude of the pressure in the fluid flow path within a negative pressure range; and

outputting an indication responsive to the measure of collapse, wherein the method is performed by the controller.

16. The method of claim 15, wherein said determining the measure of collapse comprises determining the measure of collapse from a change in the magnitude of the pressure in the fluid flow path over time.

17. The method of claim 15 or claim 16, wherein said determining the measure of collapse comprises determining the measure of collapse from a comparison of the magnitude of the pressure in the fluid flow path over time to a pressure change pattern.

18. The method of claim 17, wherein the pressure change pattern is indicative of one or more of:

- (i) pressure magnitude in the fluid flow path when the stabilizing structure is fully collapsed;
- (ii) pressure magnitude in the fluid flow path when the stabilizing structure is partially collapsed; and
- (iii) pressure magnitude in the fluid flow path when the stabilizing structure is not collapsed.

19. The method of any one of claims 15-18, wherein the measure of collapse comprises a rate of collapse of the stabilizing structure.

20. The method of any one of claims 15-19, wherein said outputting the indication comprises outputting the indication to:

- (i) activate or deactivate the negative source;
- (ii) activate or deactivate an alarm;
- (iv) increase or decrease a target negative pressure provided by the negative pressure source; or
- (v) release negative pressure in the fluid flow path.

21. The method of any one of claims 15-20, wherein said outputting the indication comprises outputting the indication to control activation and deactivation of the negative pressure source for a time period according to a target level of collapse of the stabilizing structure rather than to control activation and deactivation of the negative pressure source to adjust the magnitude of pressure to target a predetermined negative pressure threshold.

22. The method of claim 21, wherein the time period is at least 1 minute.
23. The method of any one of claims 15-22, wherein said outputting the indication comprises outputting the indication for presentation to a user or storage in a memory device.
24. The method of any one of claims 15-23, further comprising storing, in a memory device, device usage data in association with the indication, and the device usage data comprises one or more of a pressure level, an alarm, an exudate level, an event log, and an operation use time.
25. The method of any one of claims 15-24, further comprising determining whether the wound dressing comprises the stabilizing structure from the pressure in the fluid flow path.
26. The method of any one of claims 15-25, wherein said monitoring the pressure in the fluid flow path comprises monitoring the pressure in the fluid flow path at the wound dressing, in one or more lumens of the fluid flow path, or at an inlet of the negative pressure source.
27. The method of any one of claims 15-26, wherein the negative pressure source is configured to perform negative pressure therapy when a magnitude of the pressure in the fluid flow path is maintained within the negative pressure range.

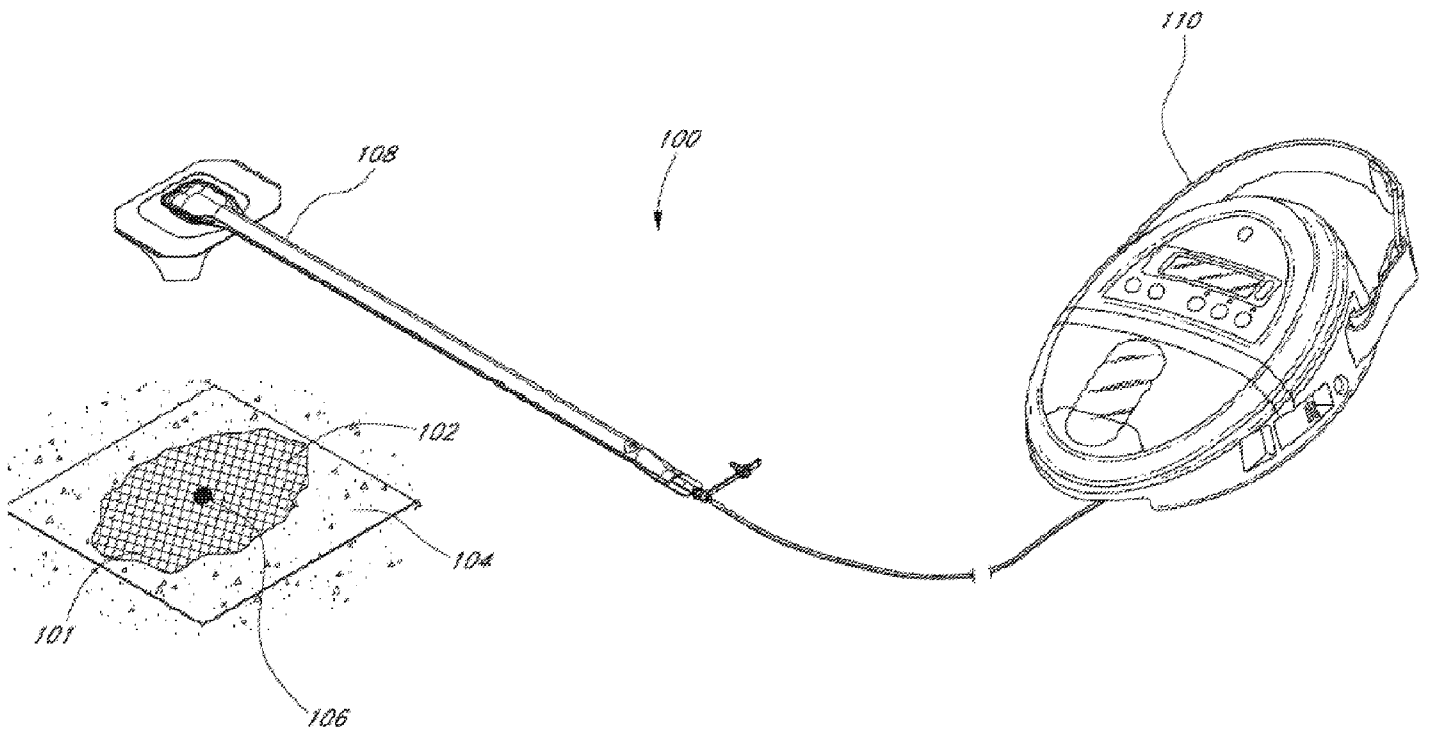

FIG. 1

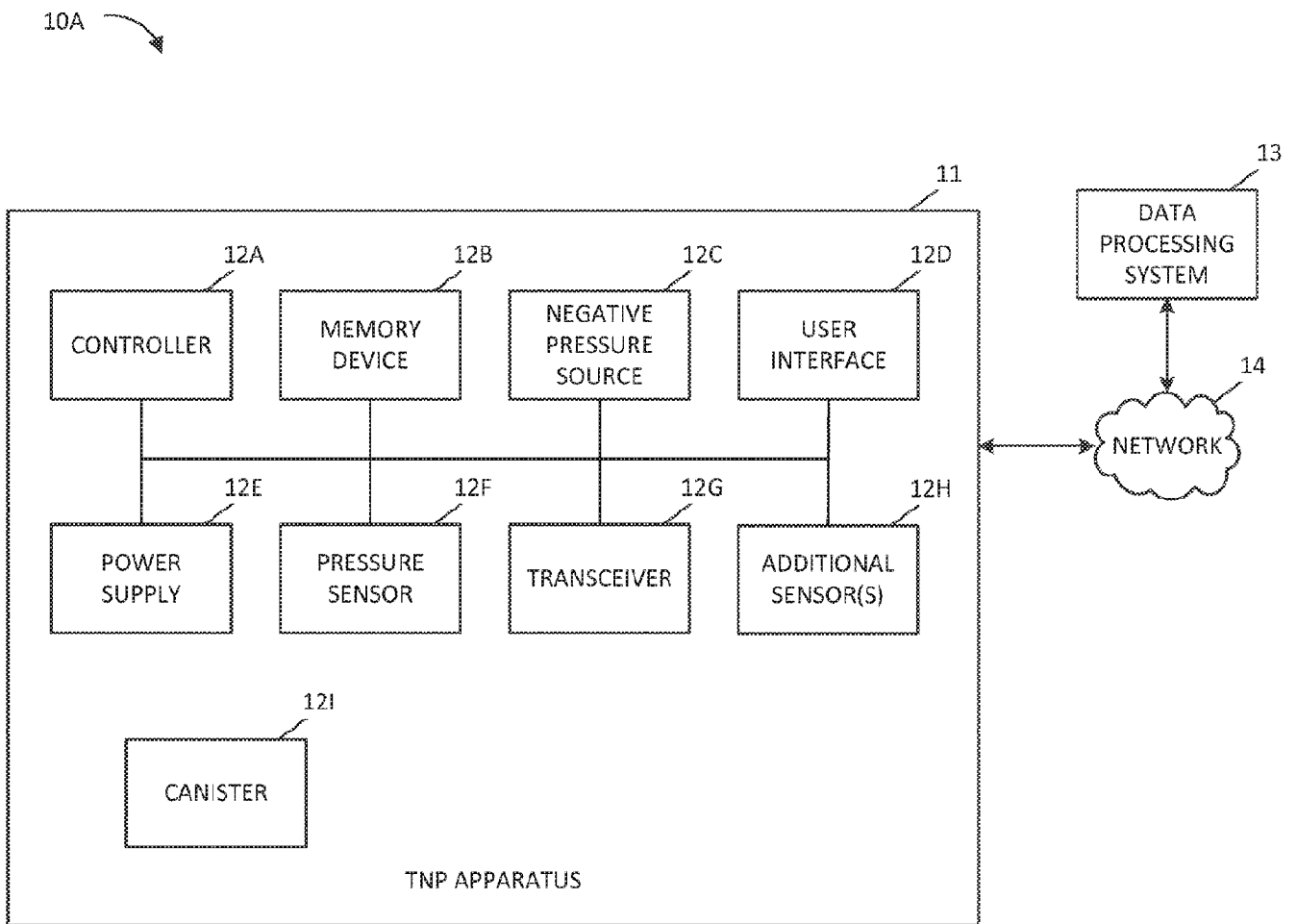

FIG. 2

10B

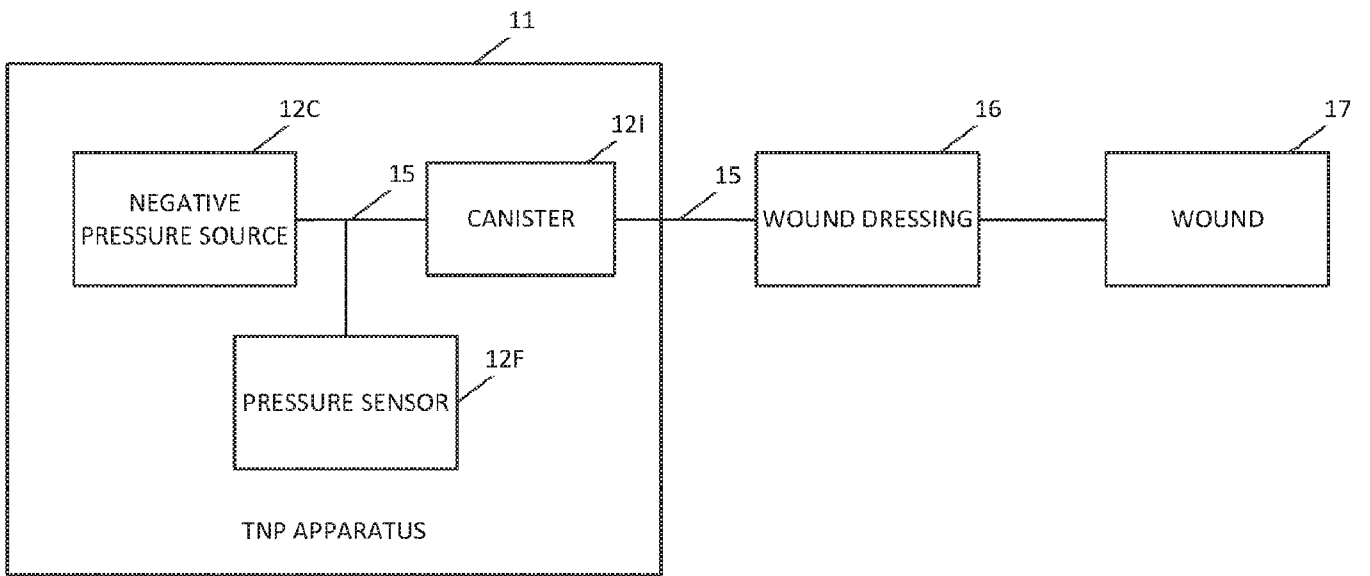

FIG. 3

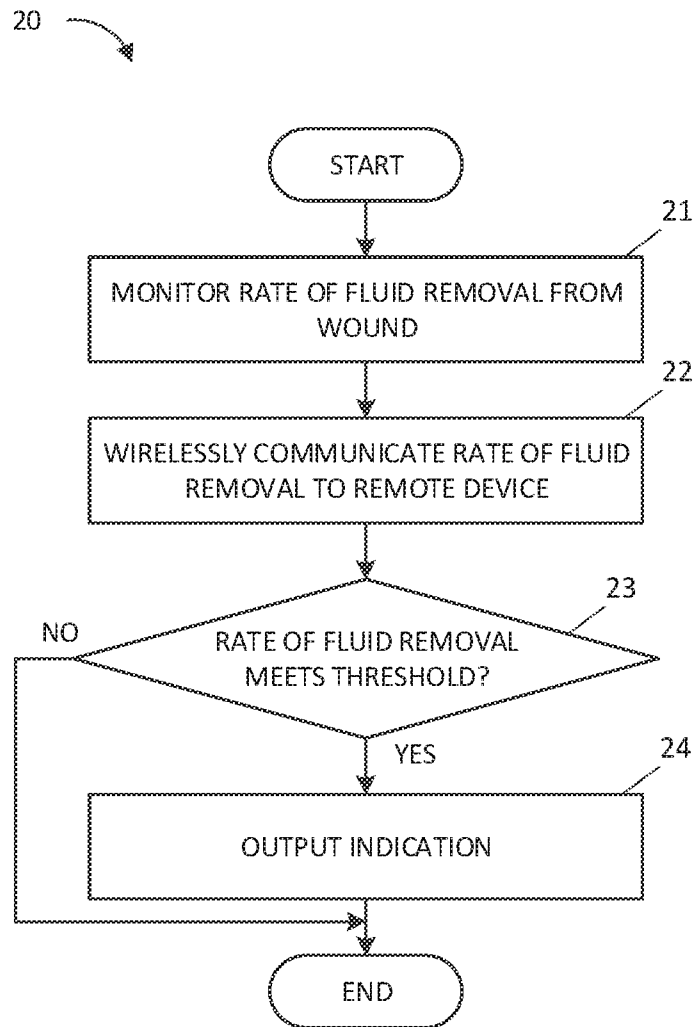

FIG. 4A

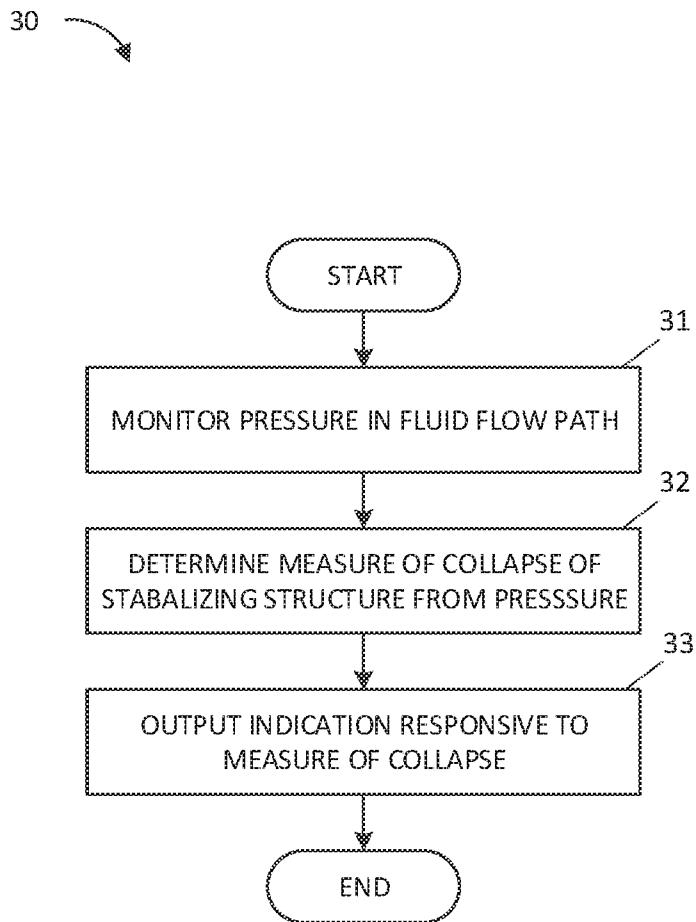

FIG. 4B

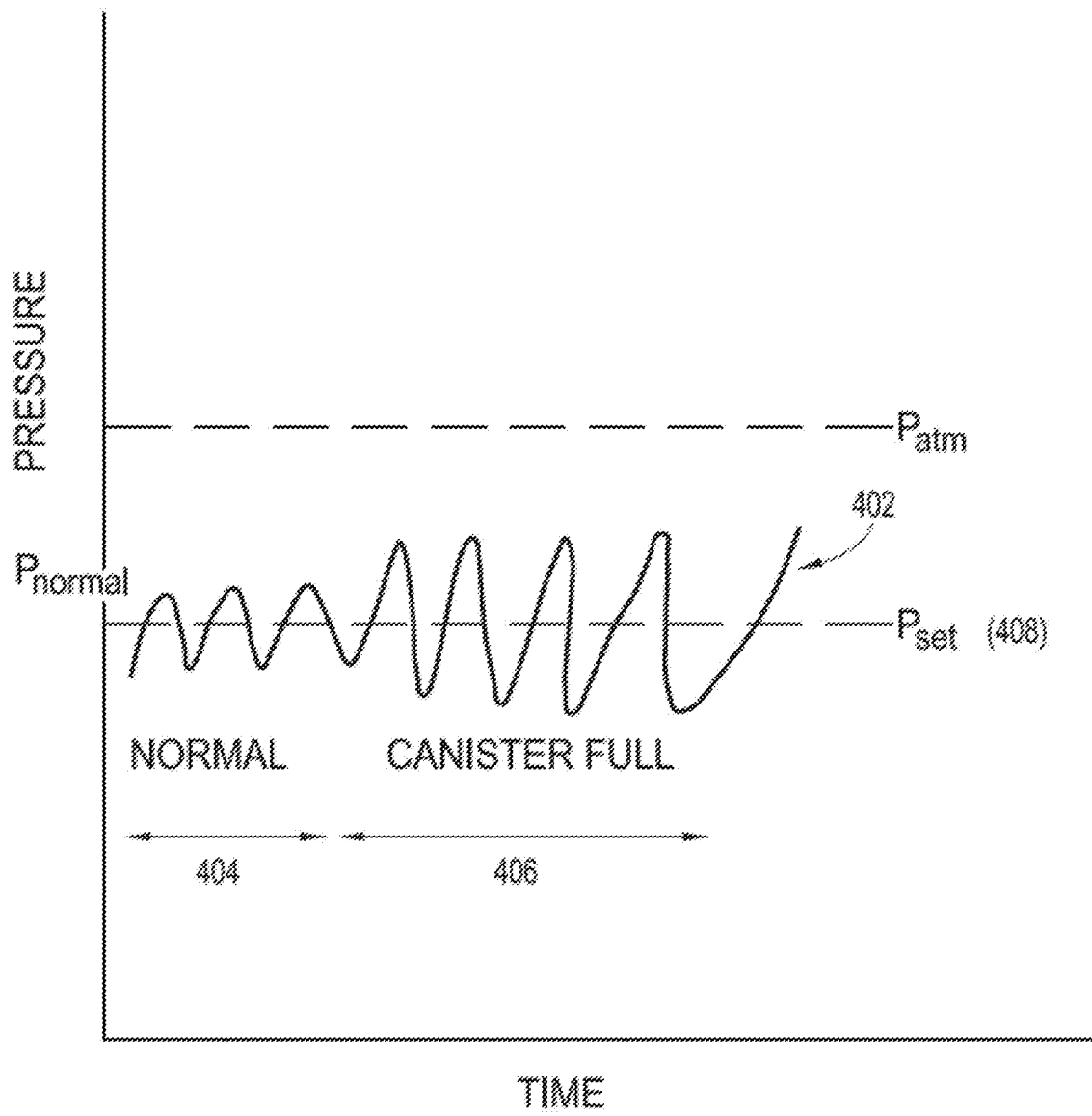

FIG. 5

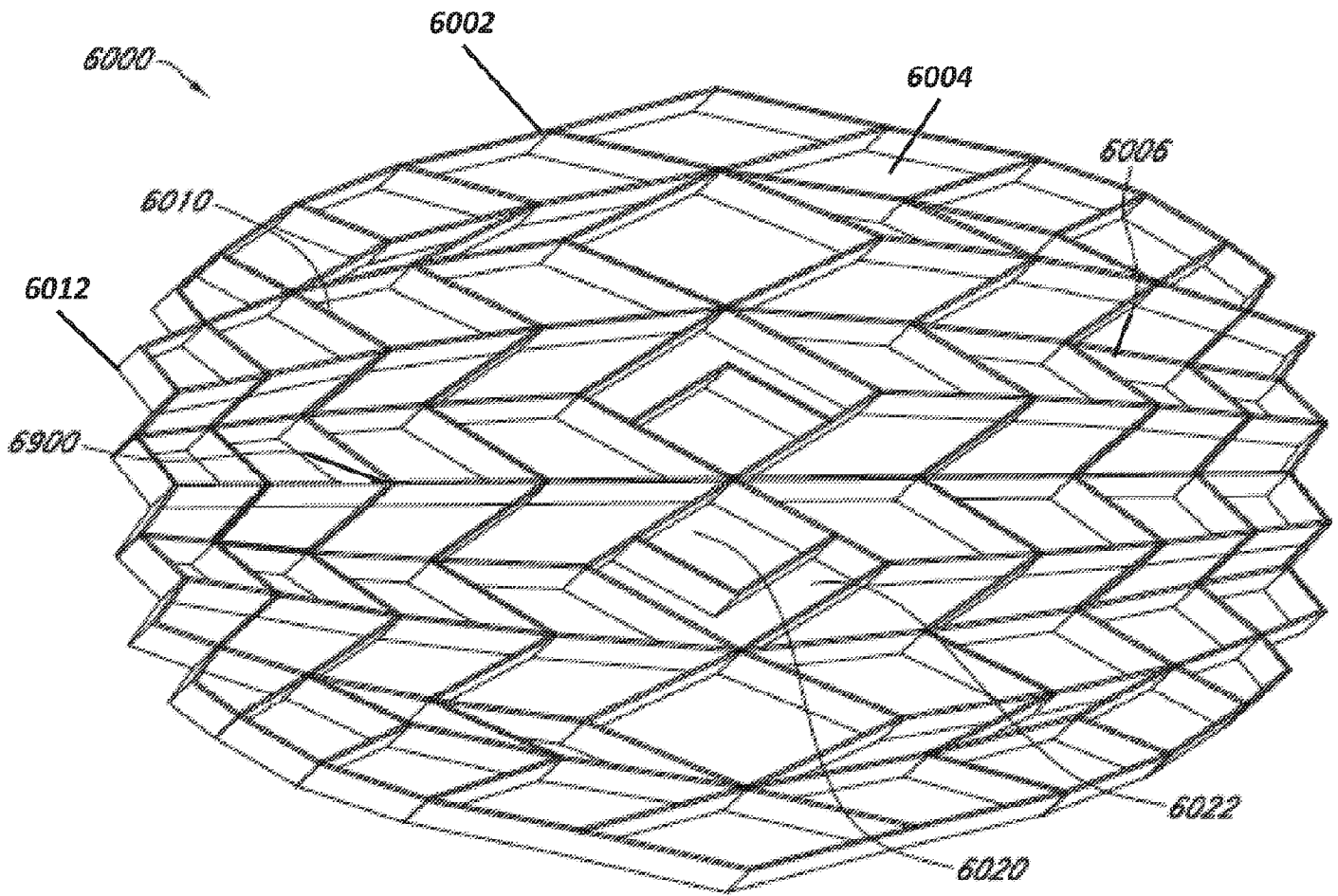

FIG. 6A

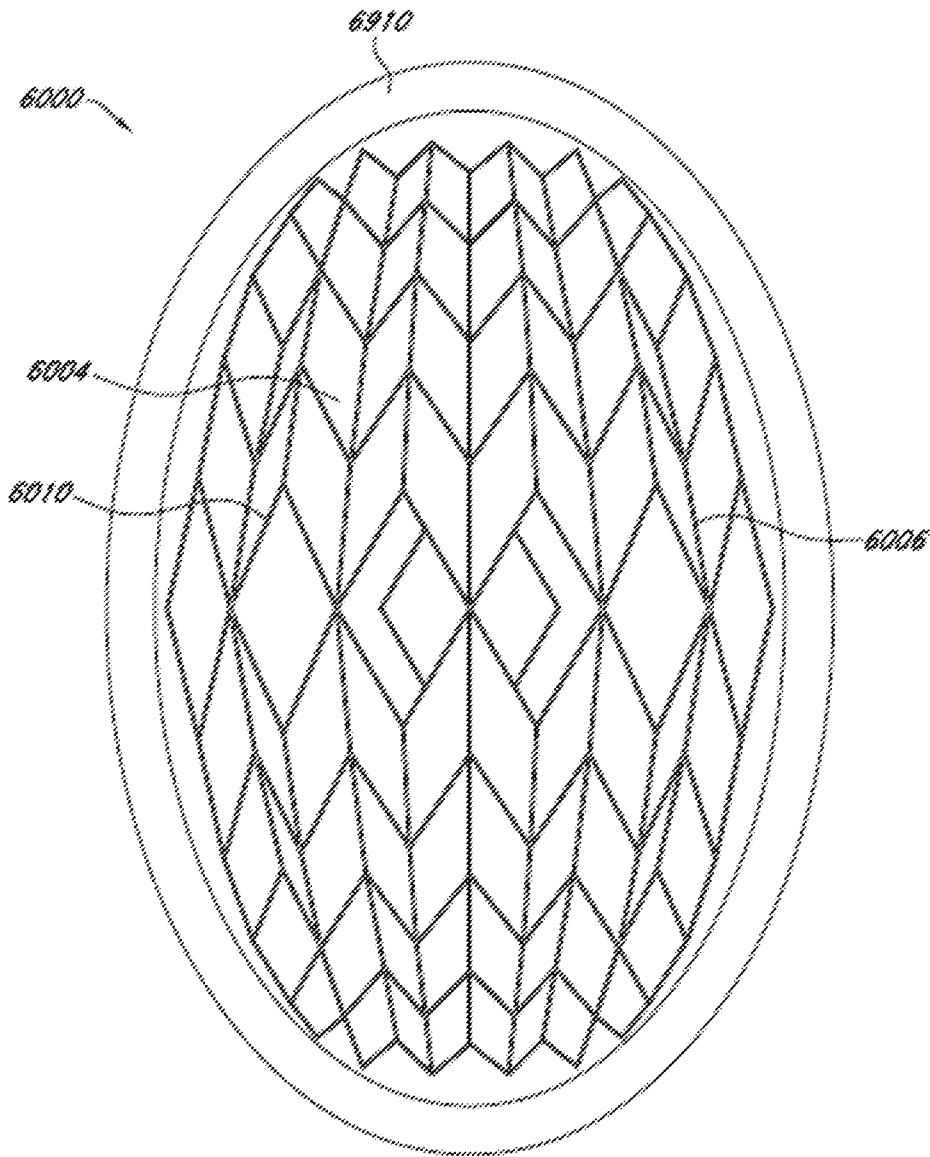

FIG. 6B

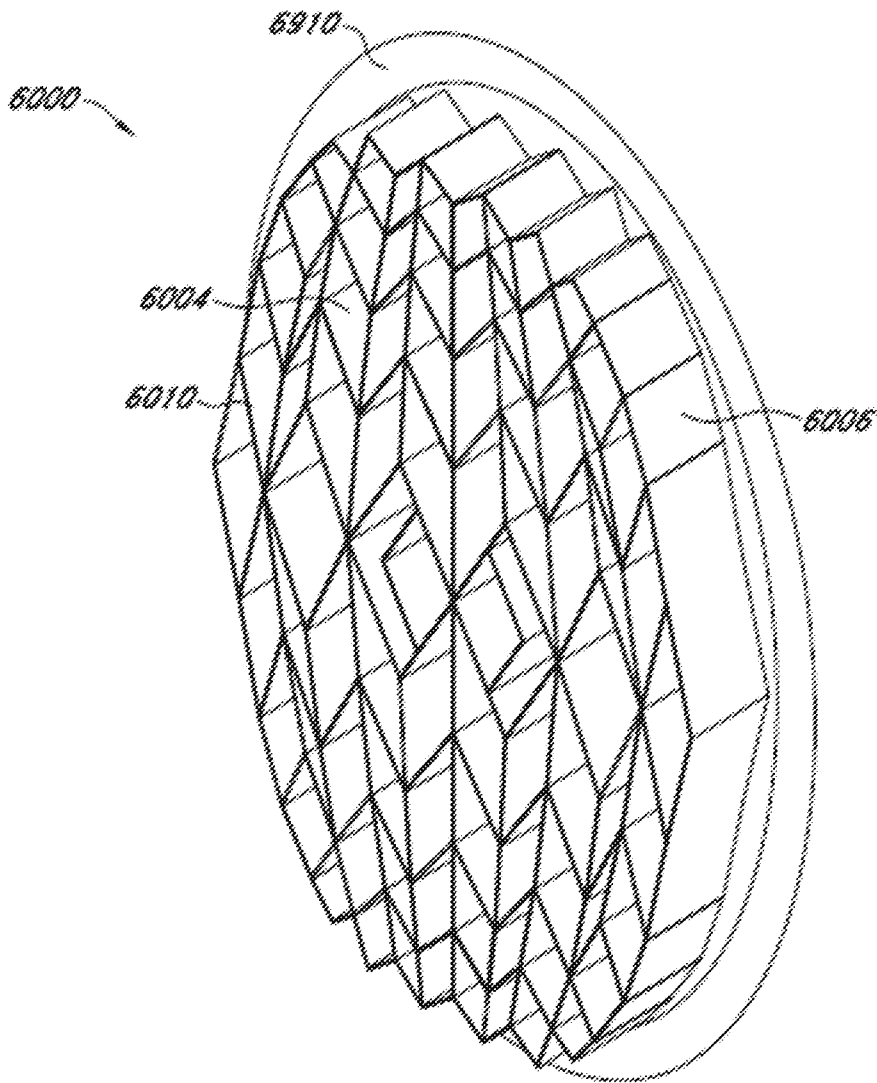

FIG. 6C

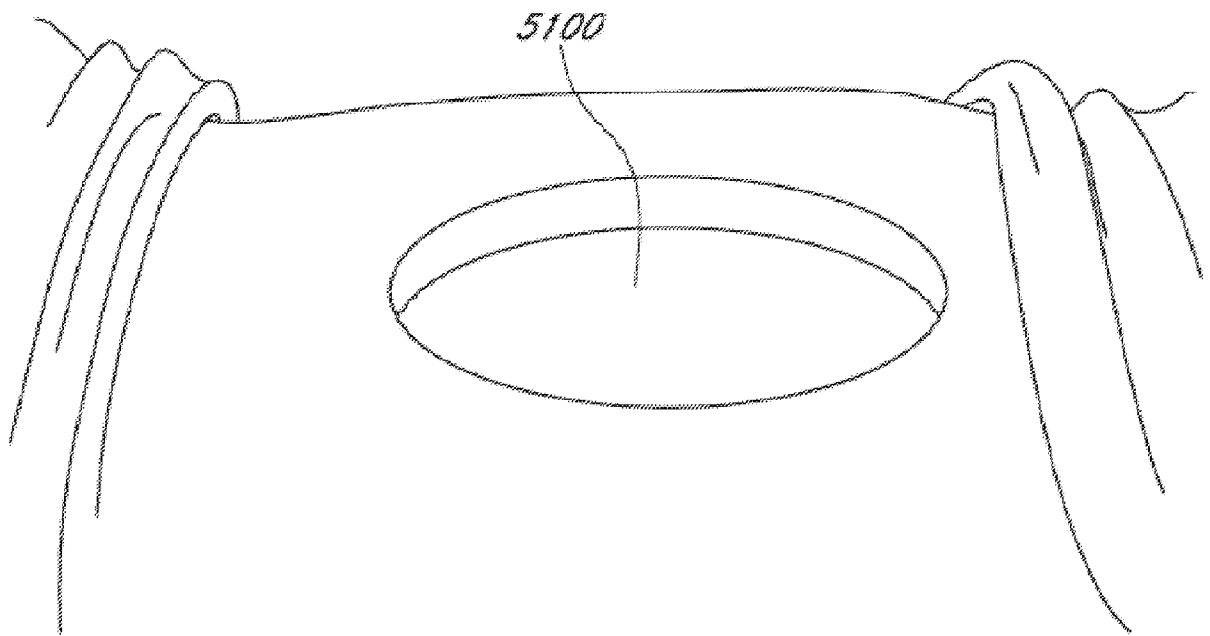

FIG. 7

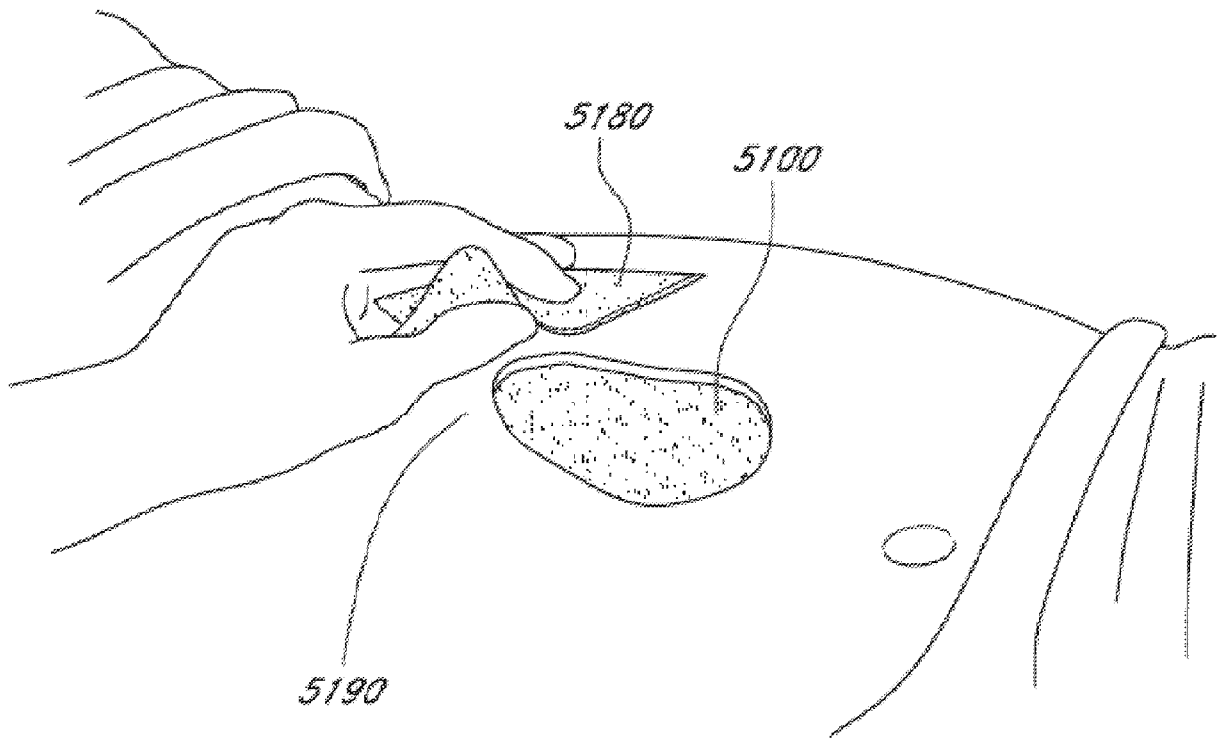

FIG. 8

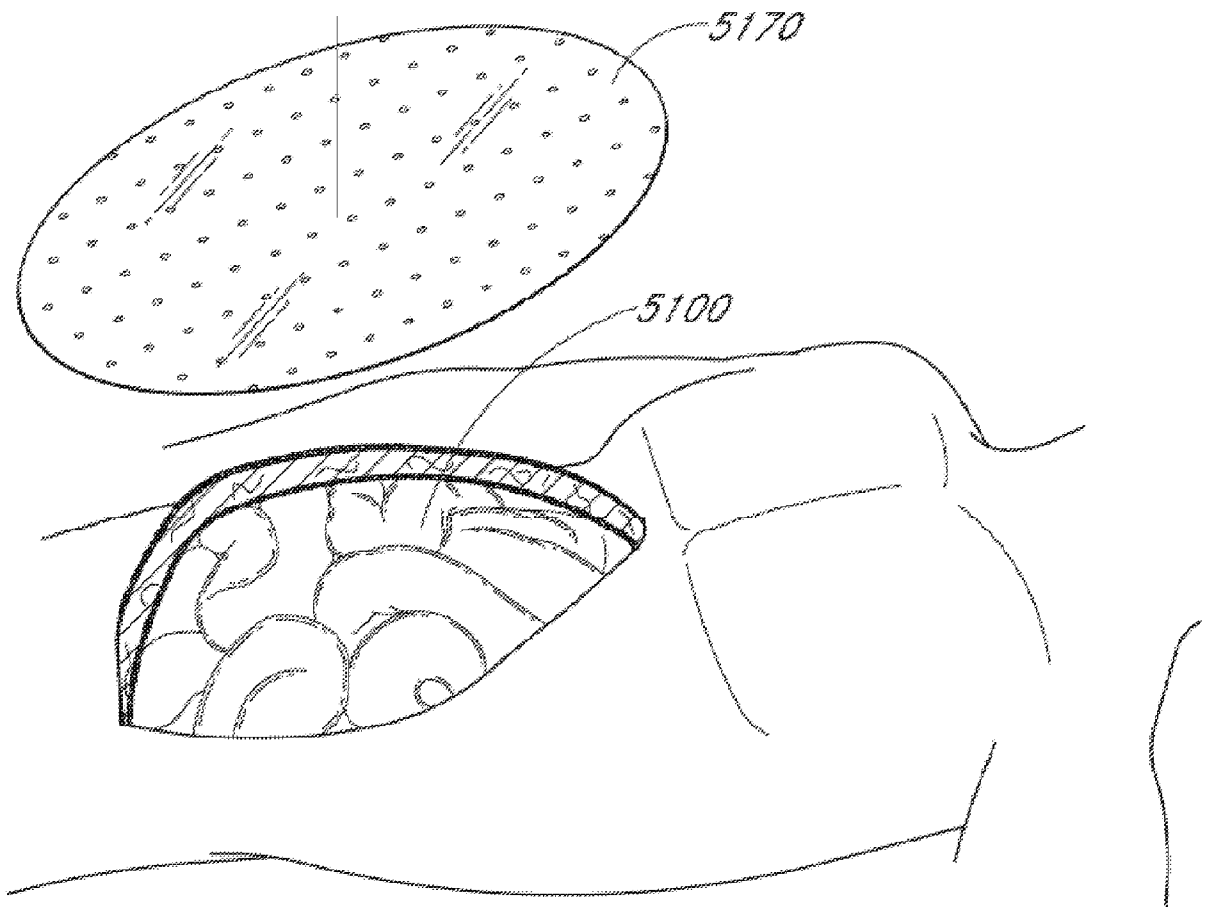

FIG. 9

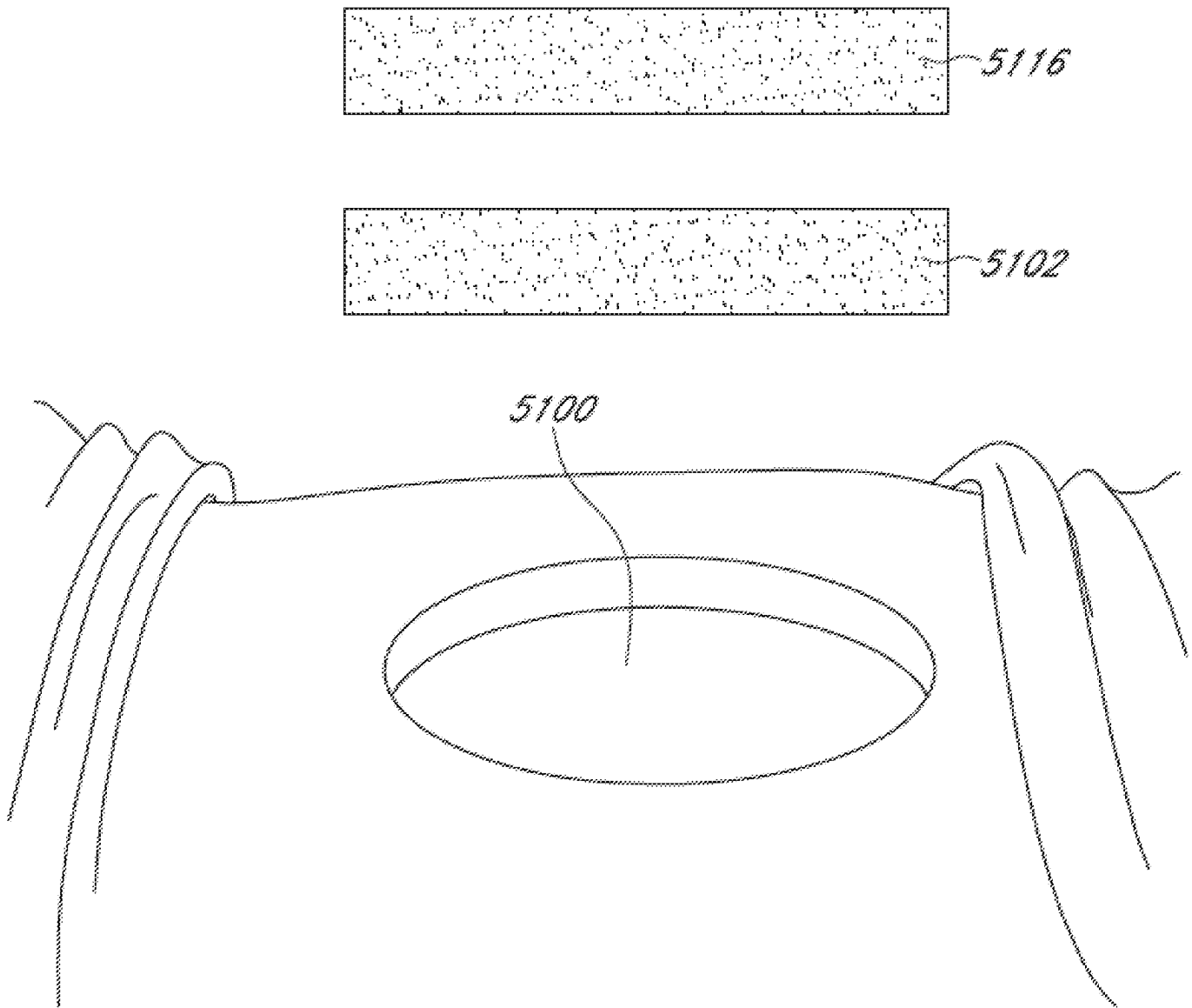

FIG. 10A

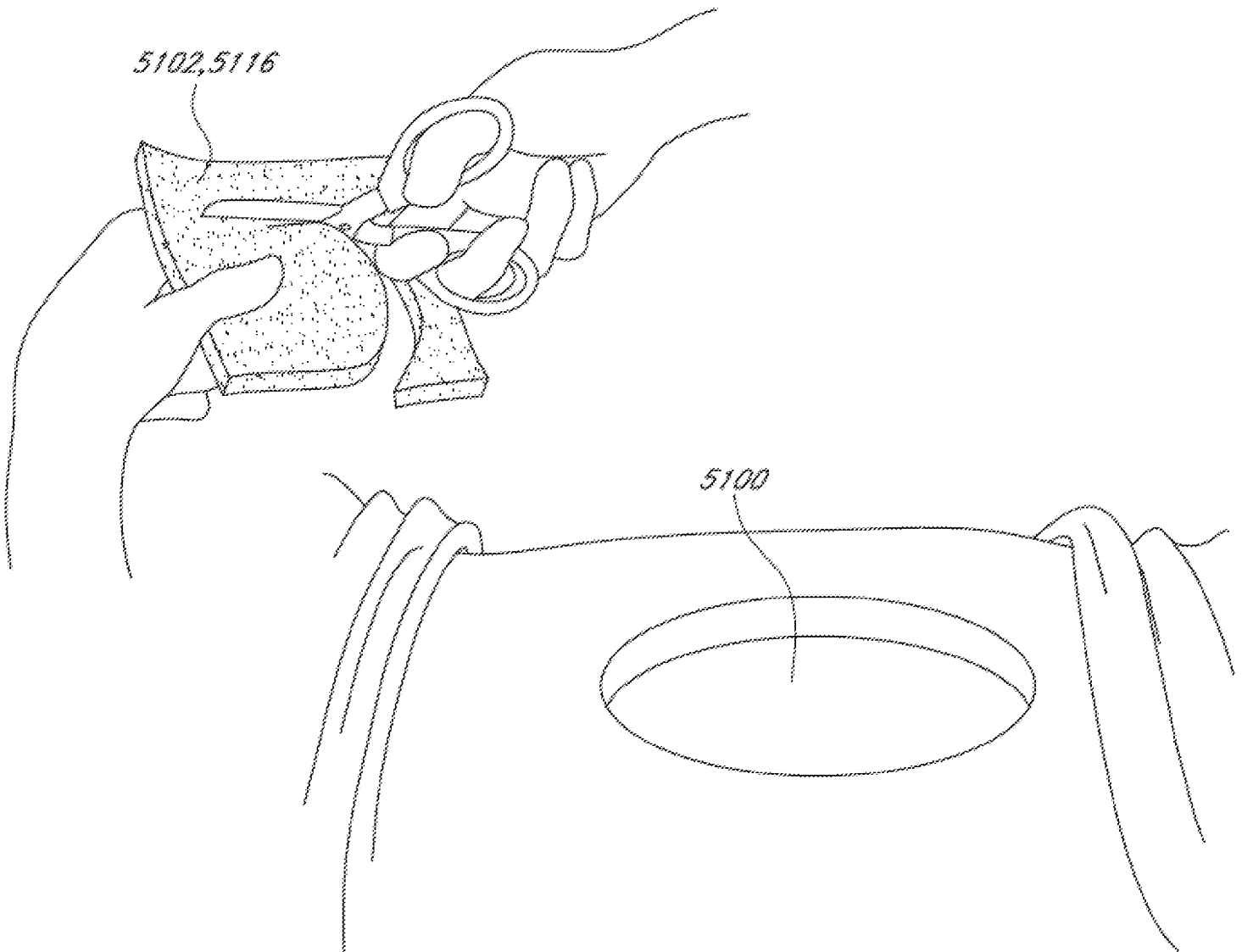

FIG. 10B

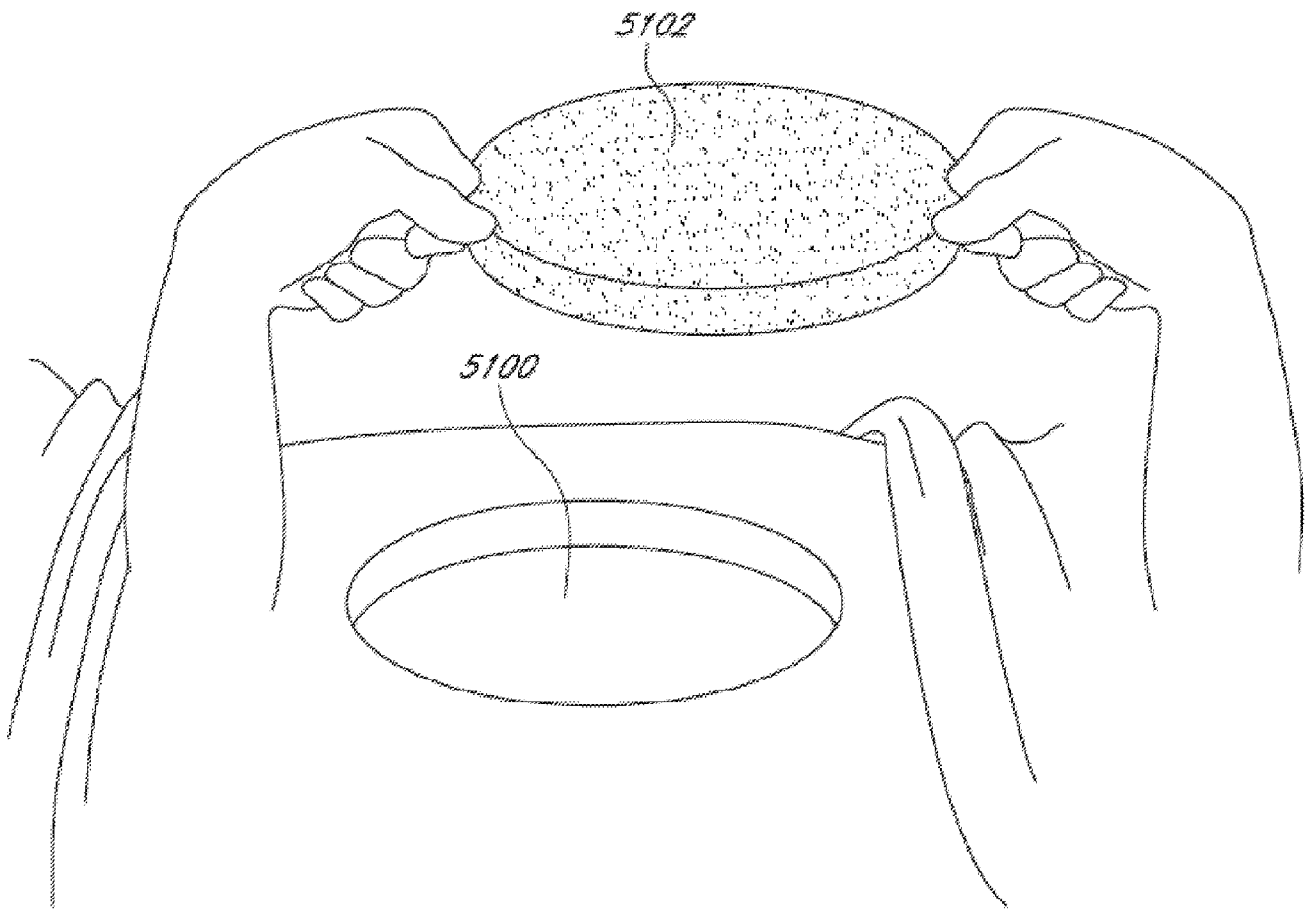

FIG. 10C

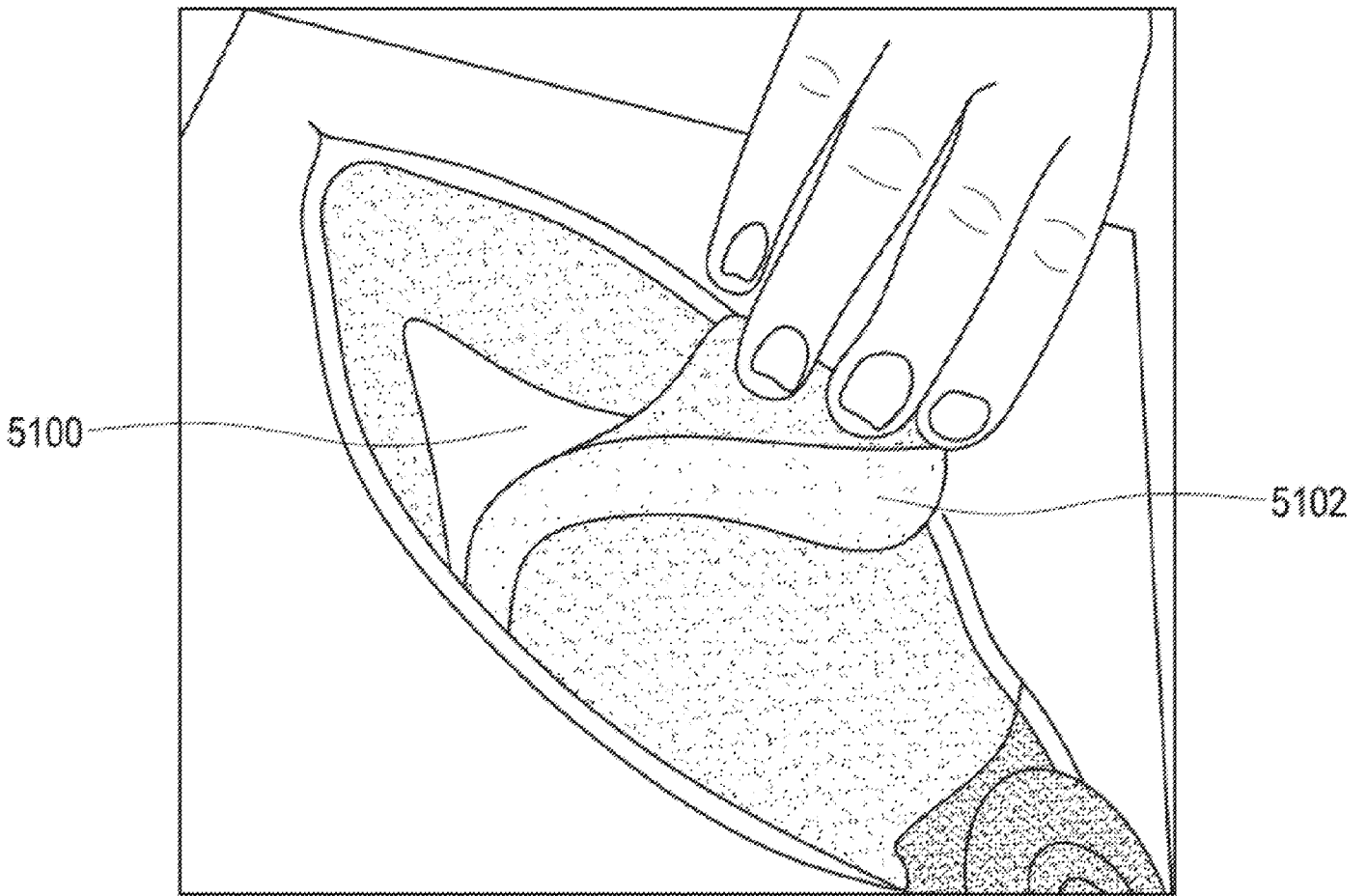

FIG. 11A

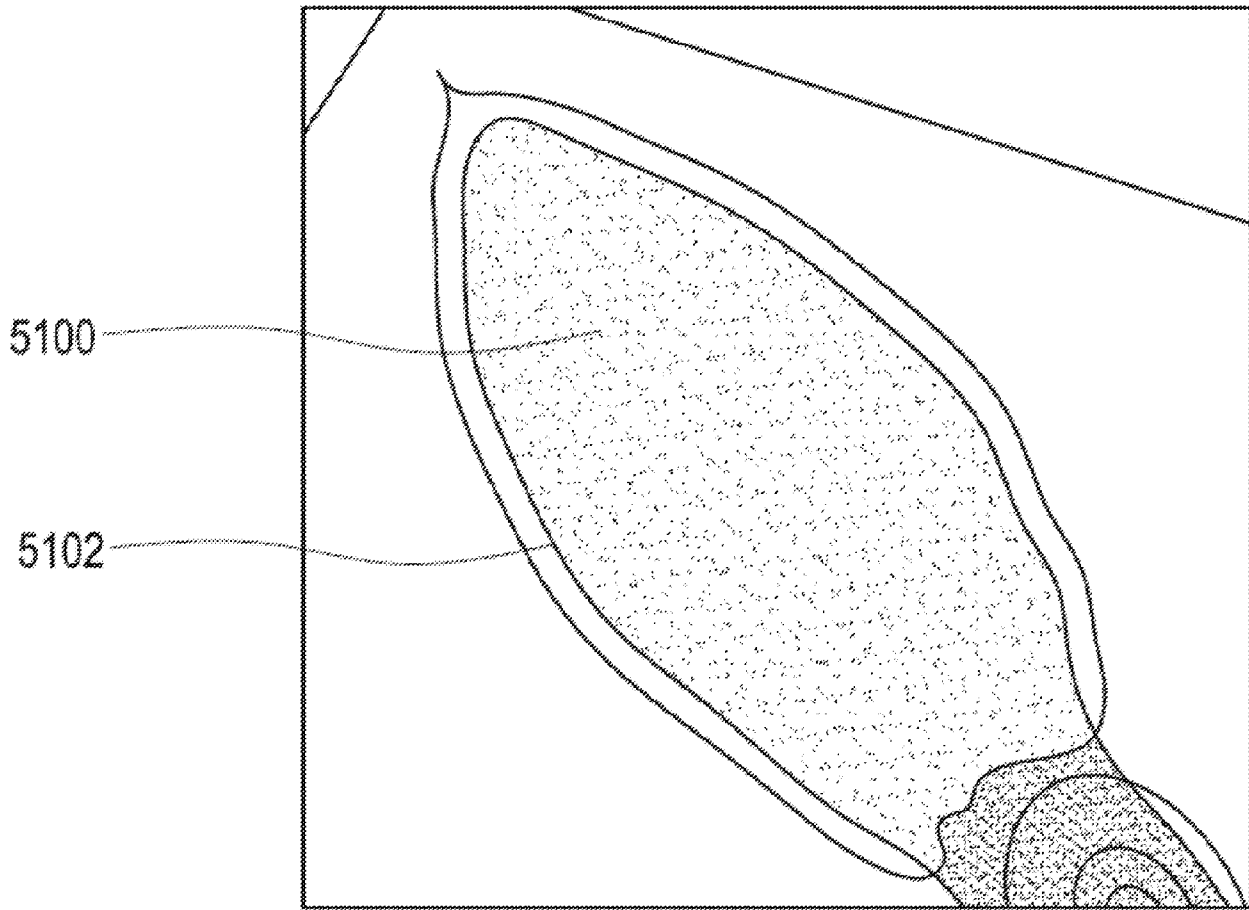

FIG. 11B

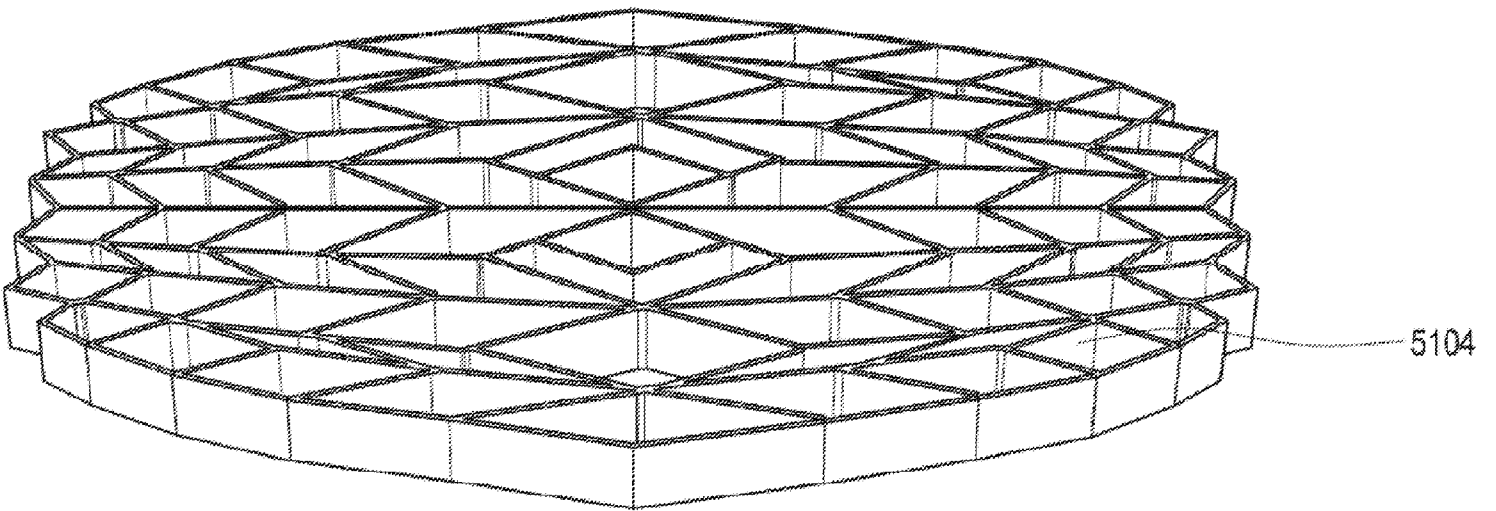

FIG. 12A

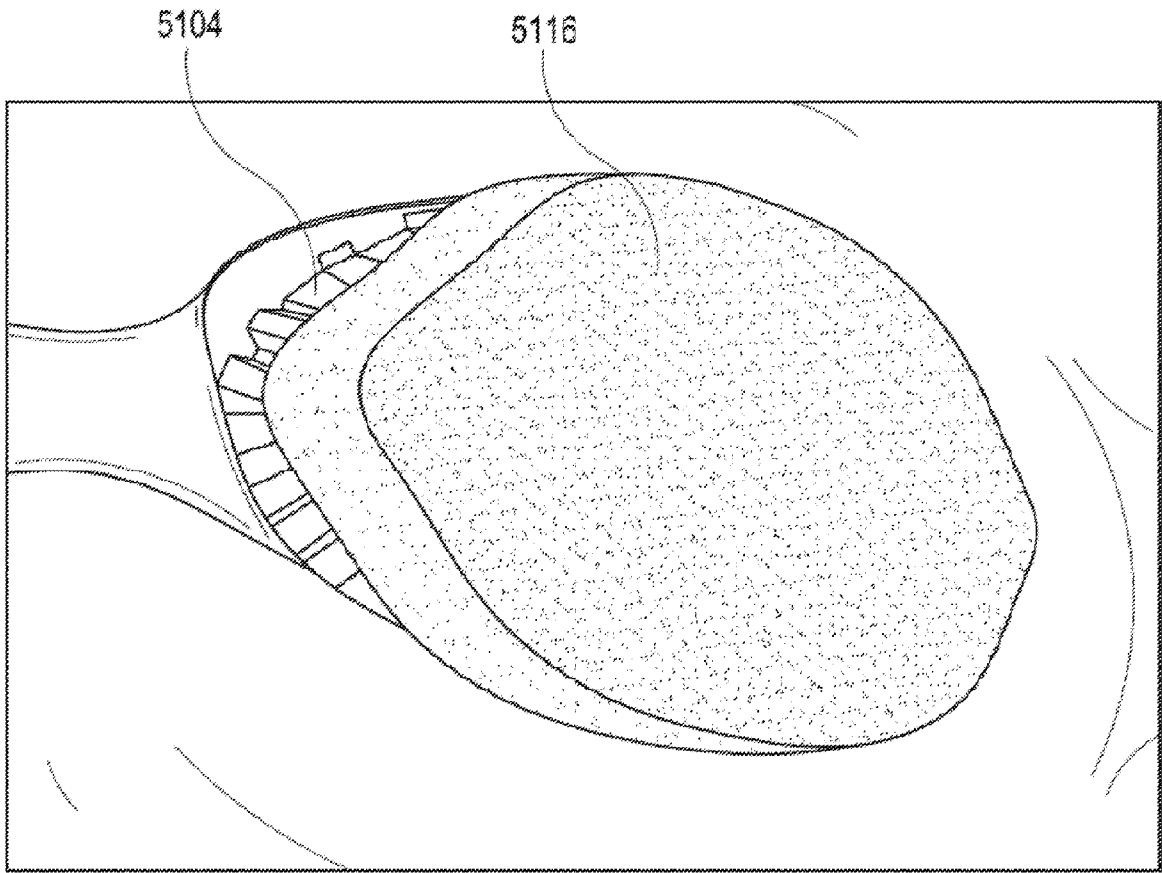

FIG. 12B

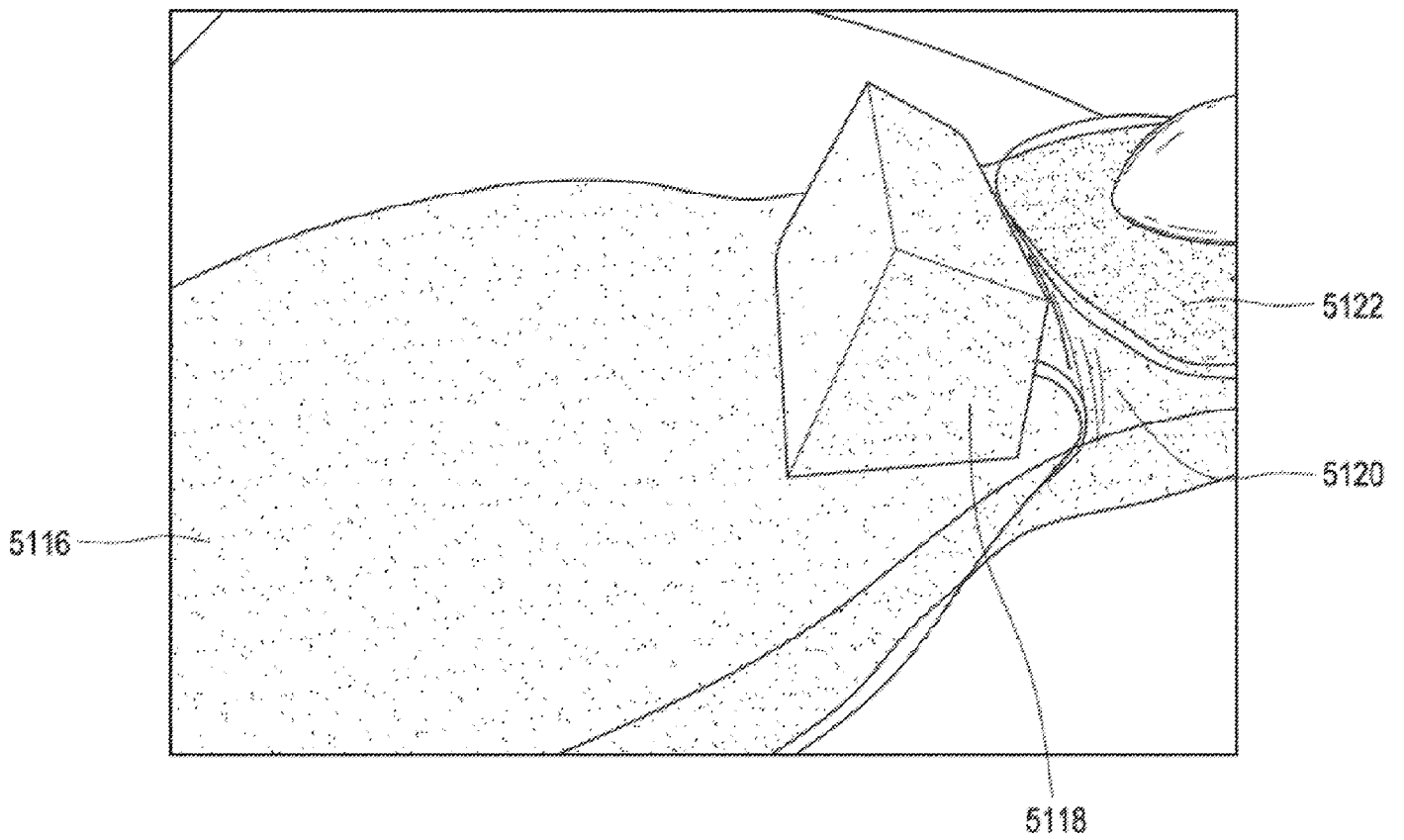

FIG. 12C

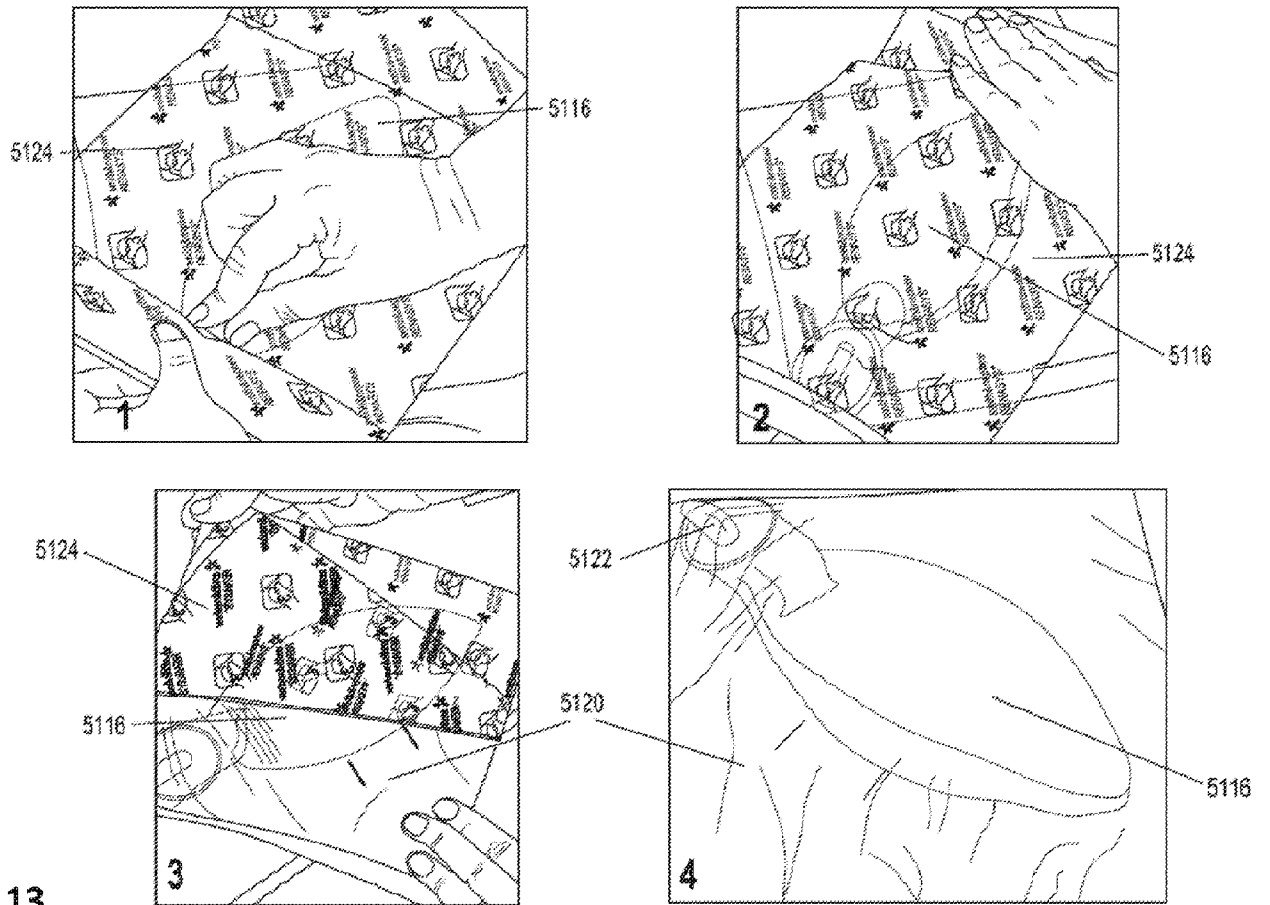

FIG. 13

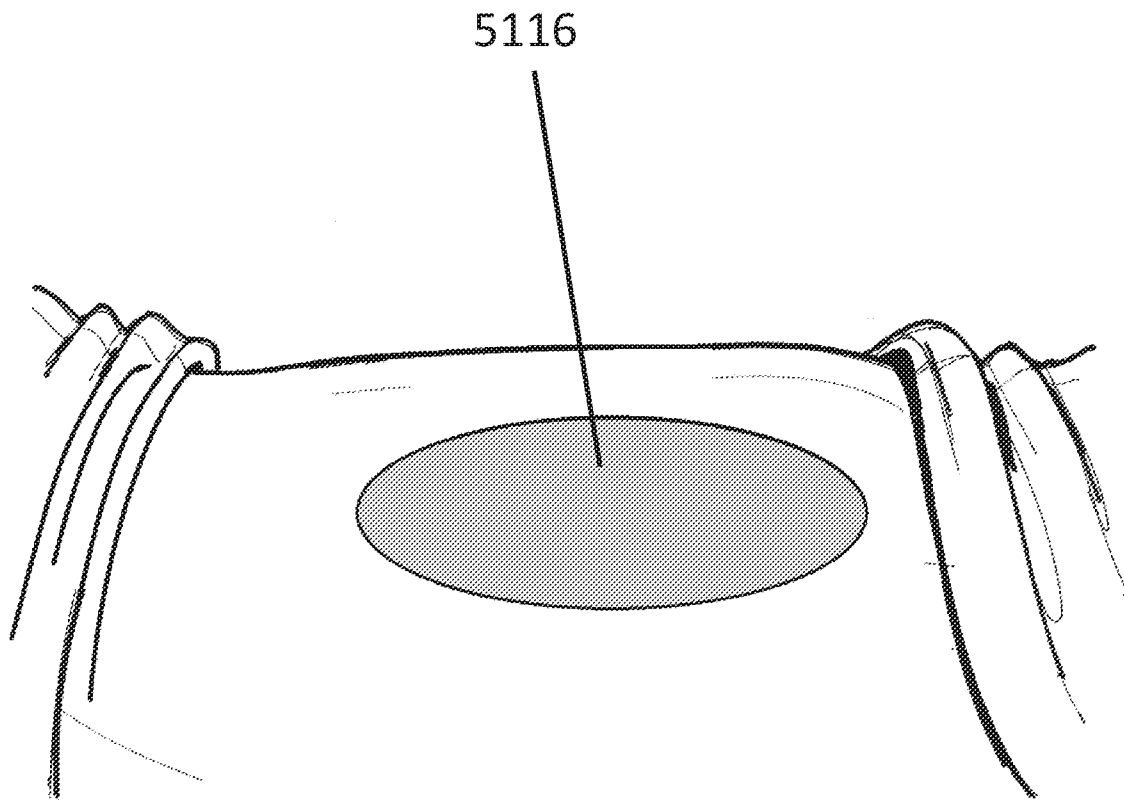

FIG. 14A

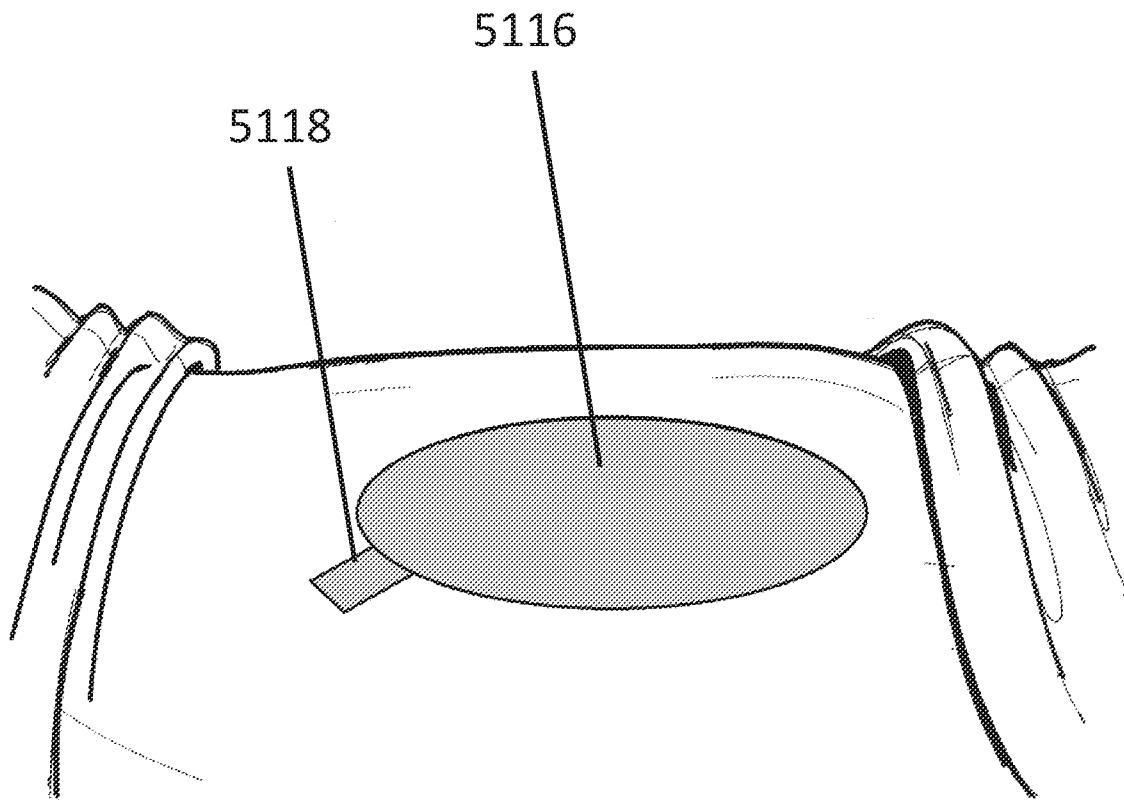

FIG. 14B

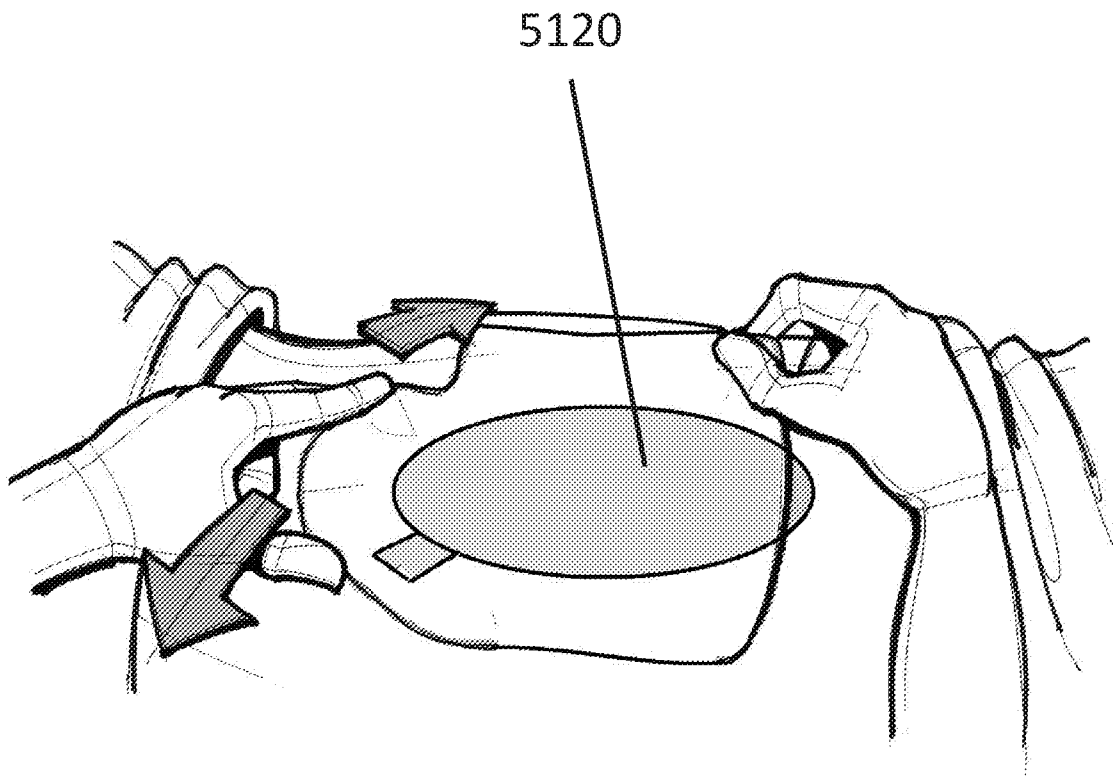

FIG. 14C

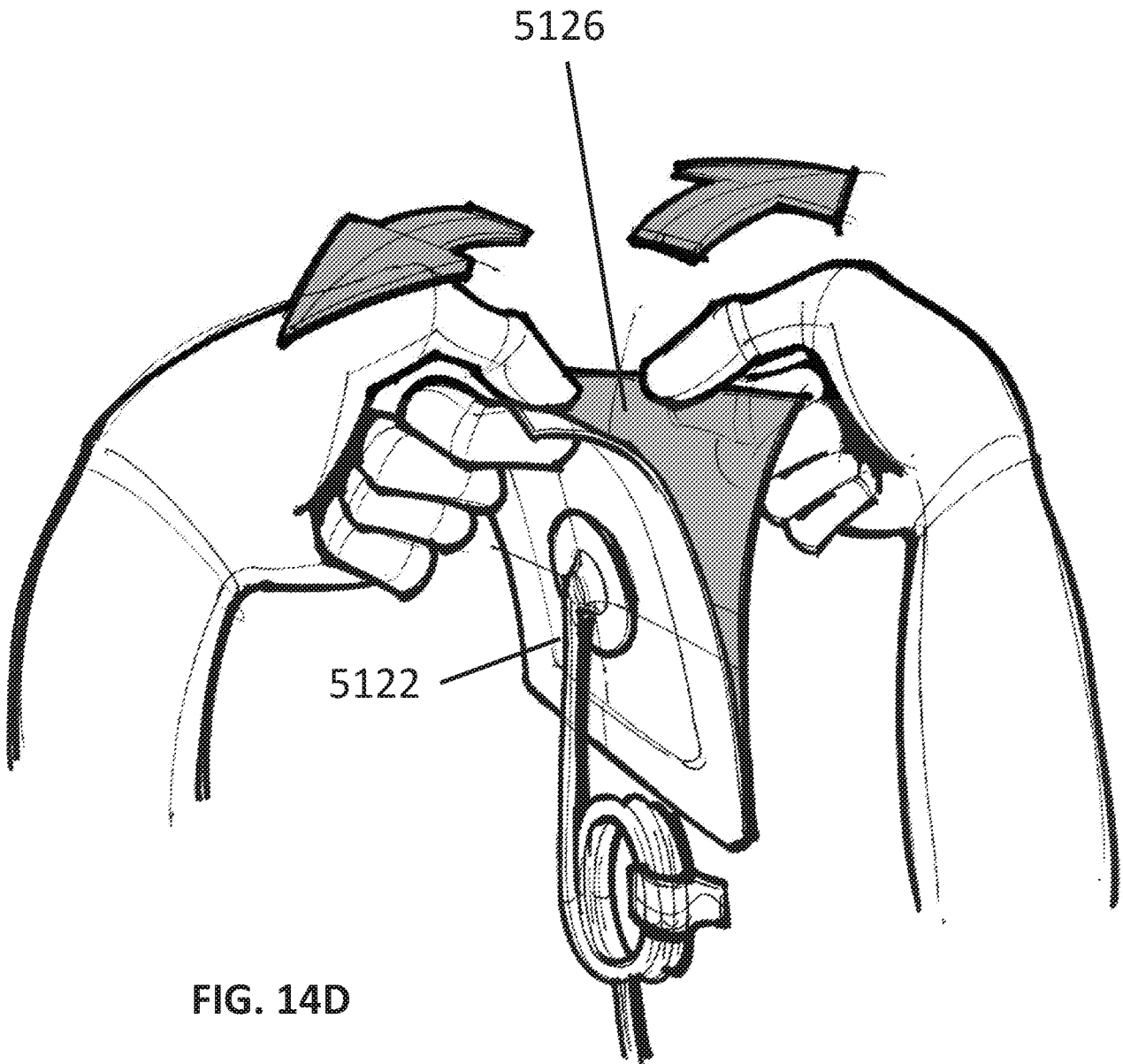

FIG. 14D

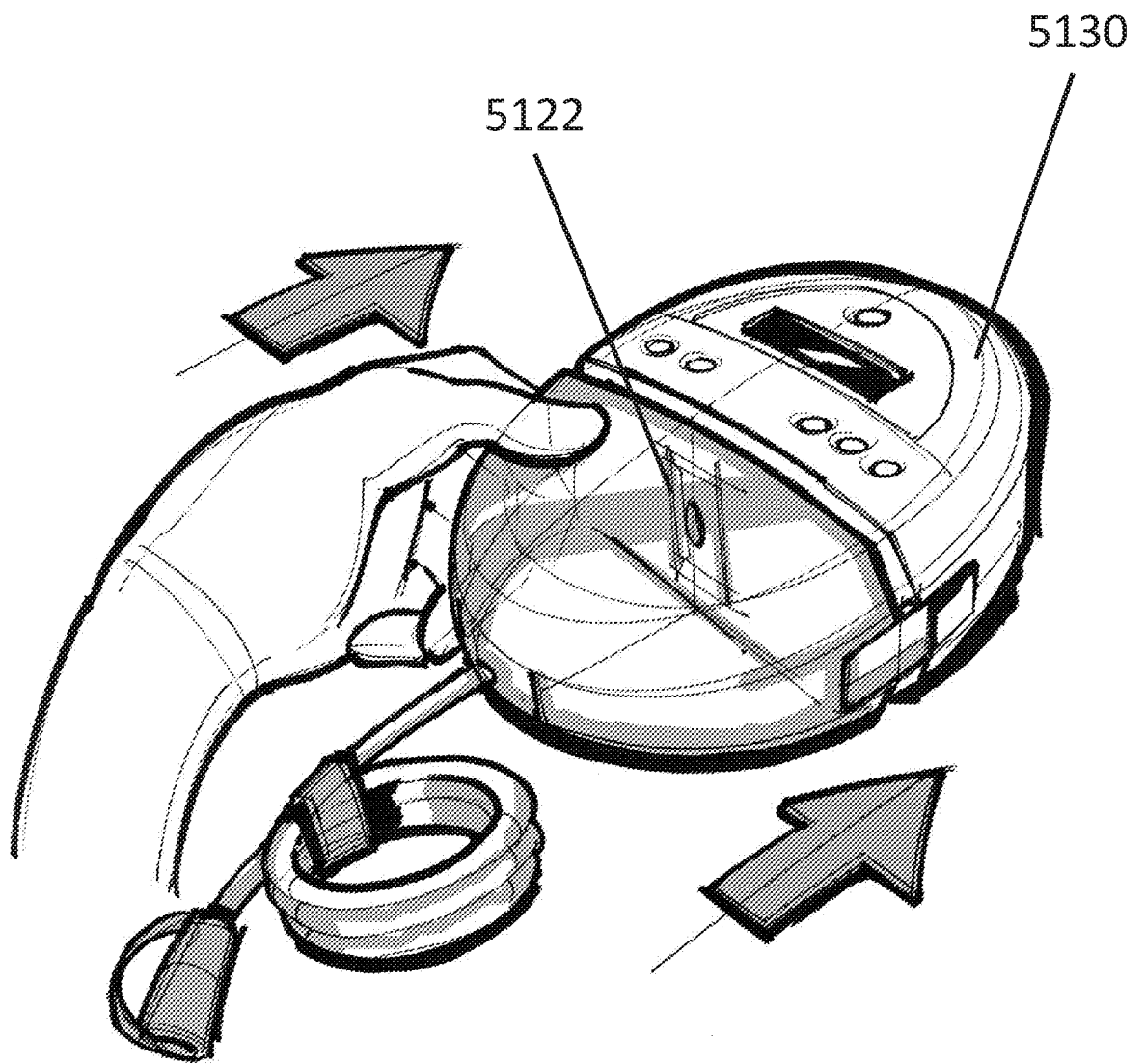

FIG. 14E

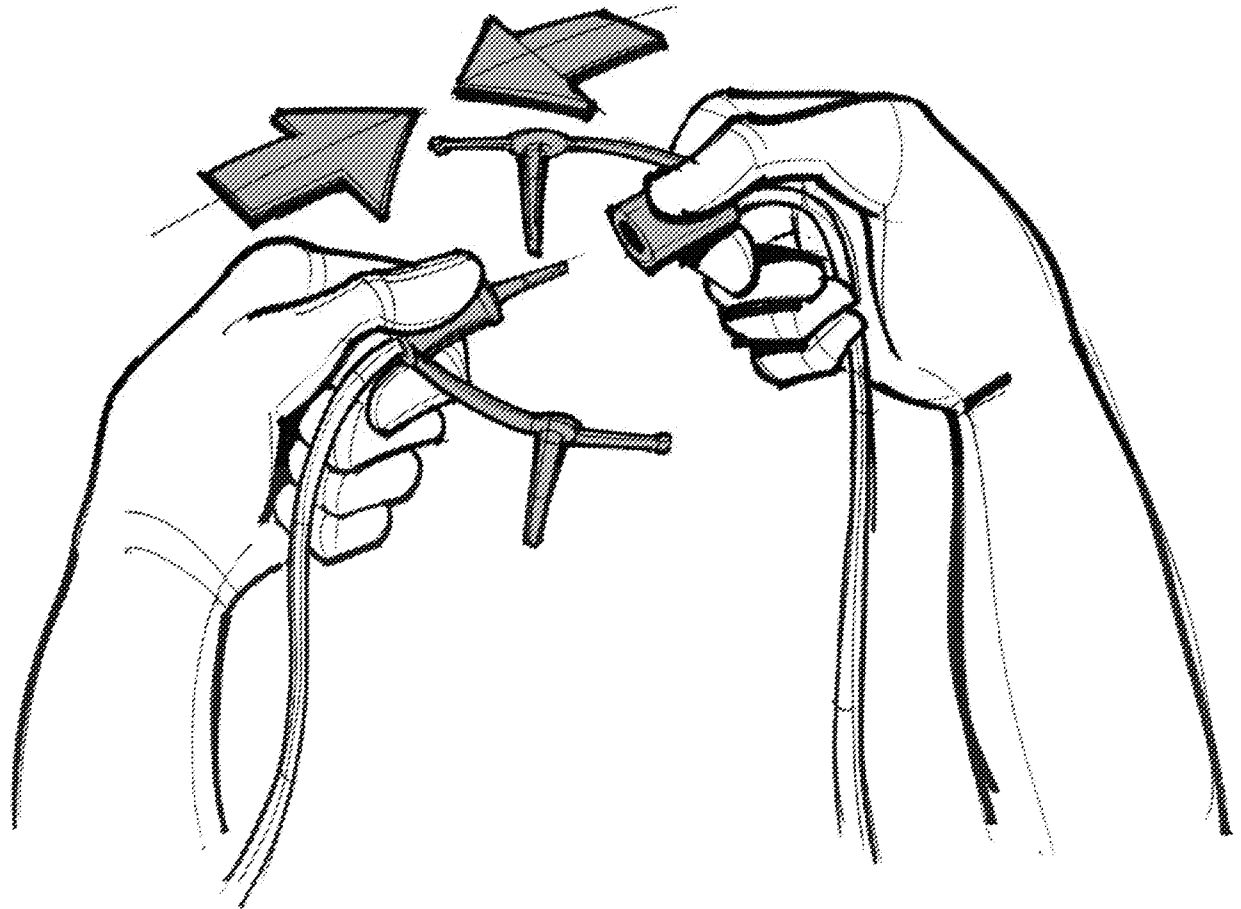

FIG. 14F

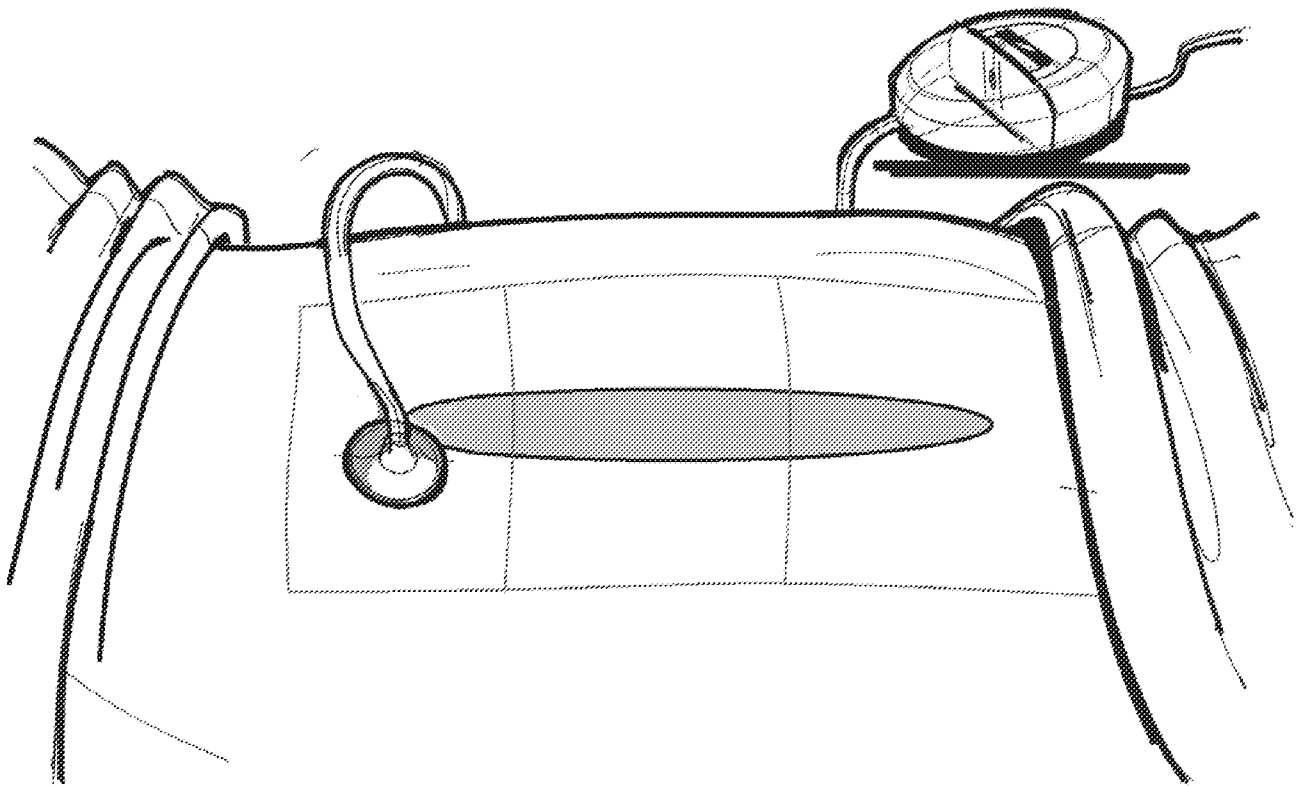

FIG. 14G

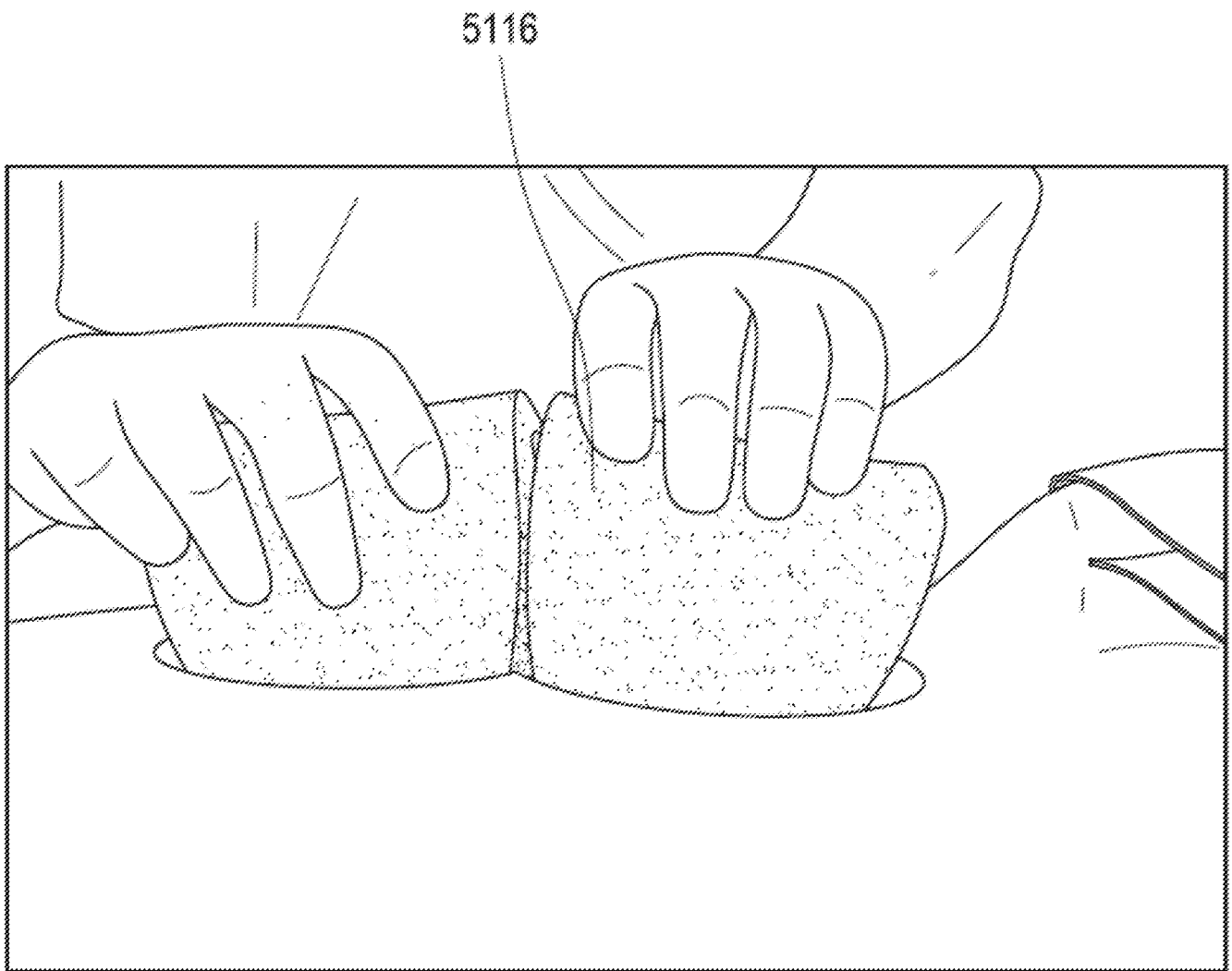

FIG. 15A

5116

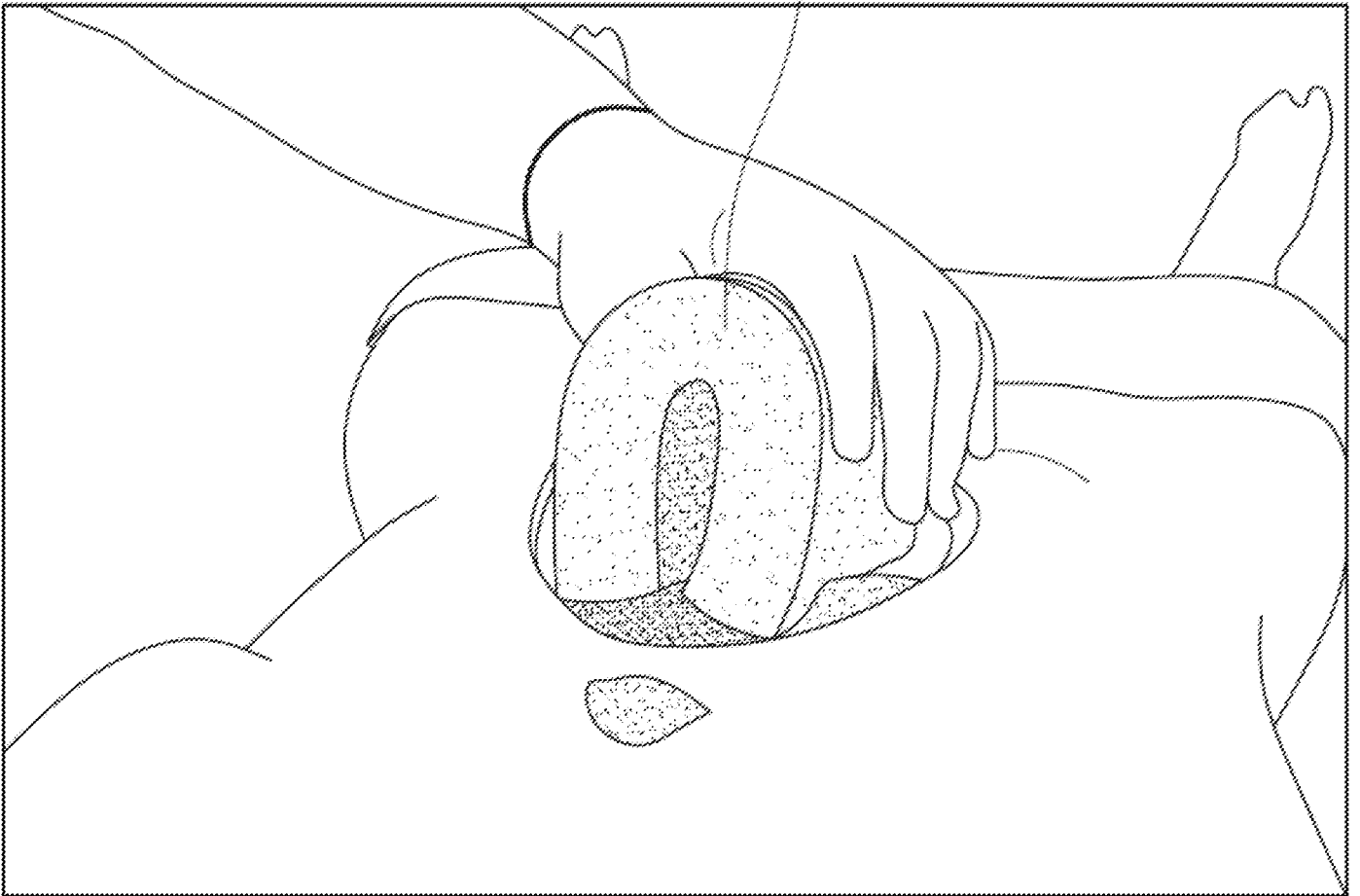

FIG. 15B

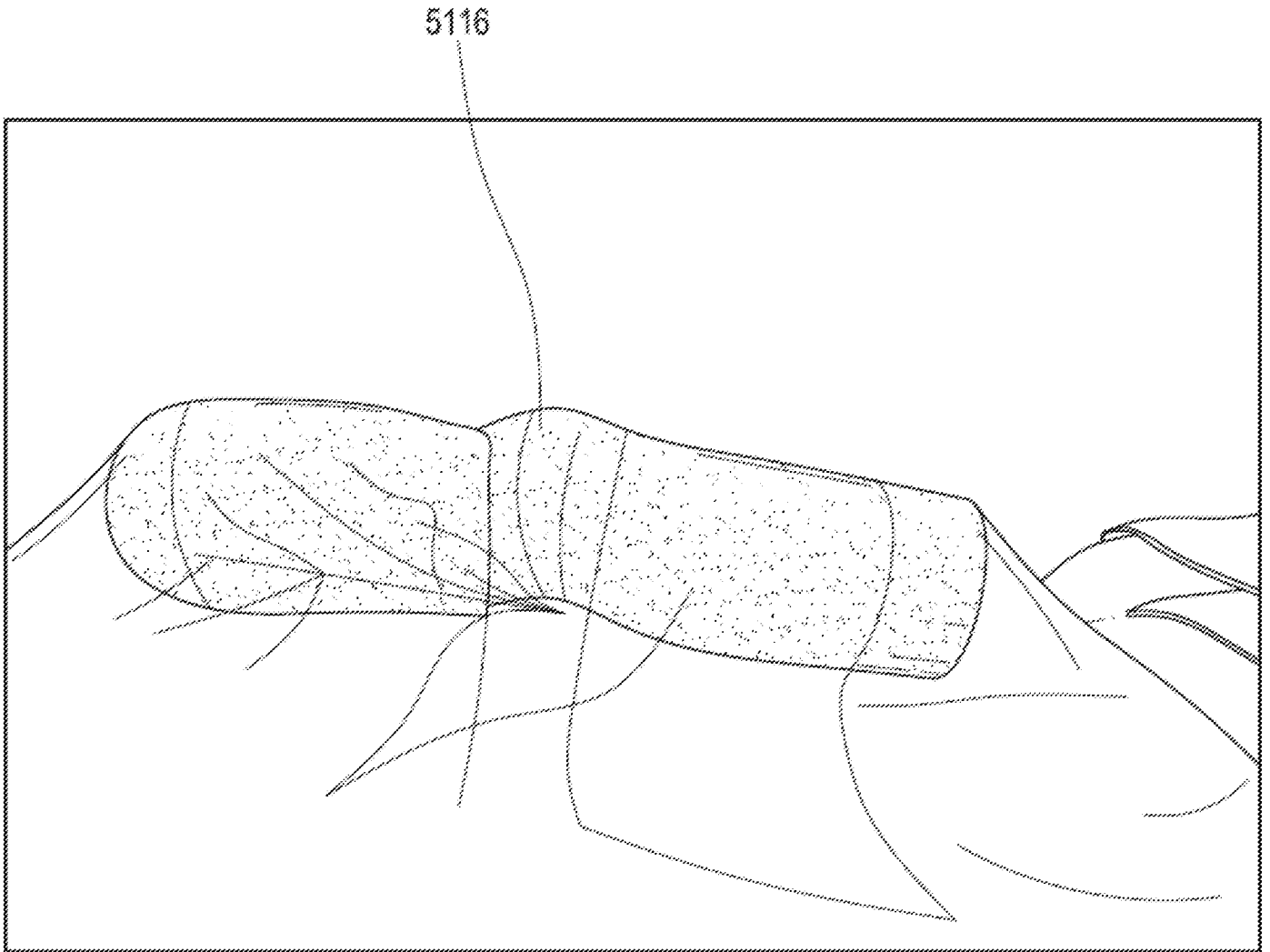

FIG. 15C

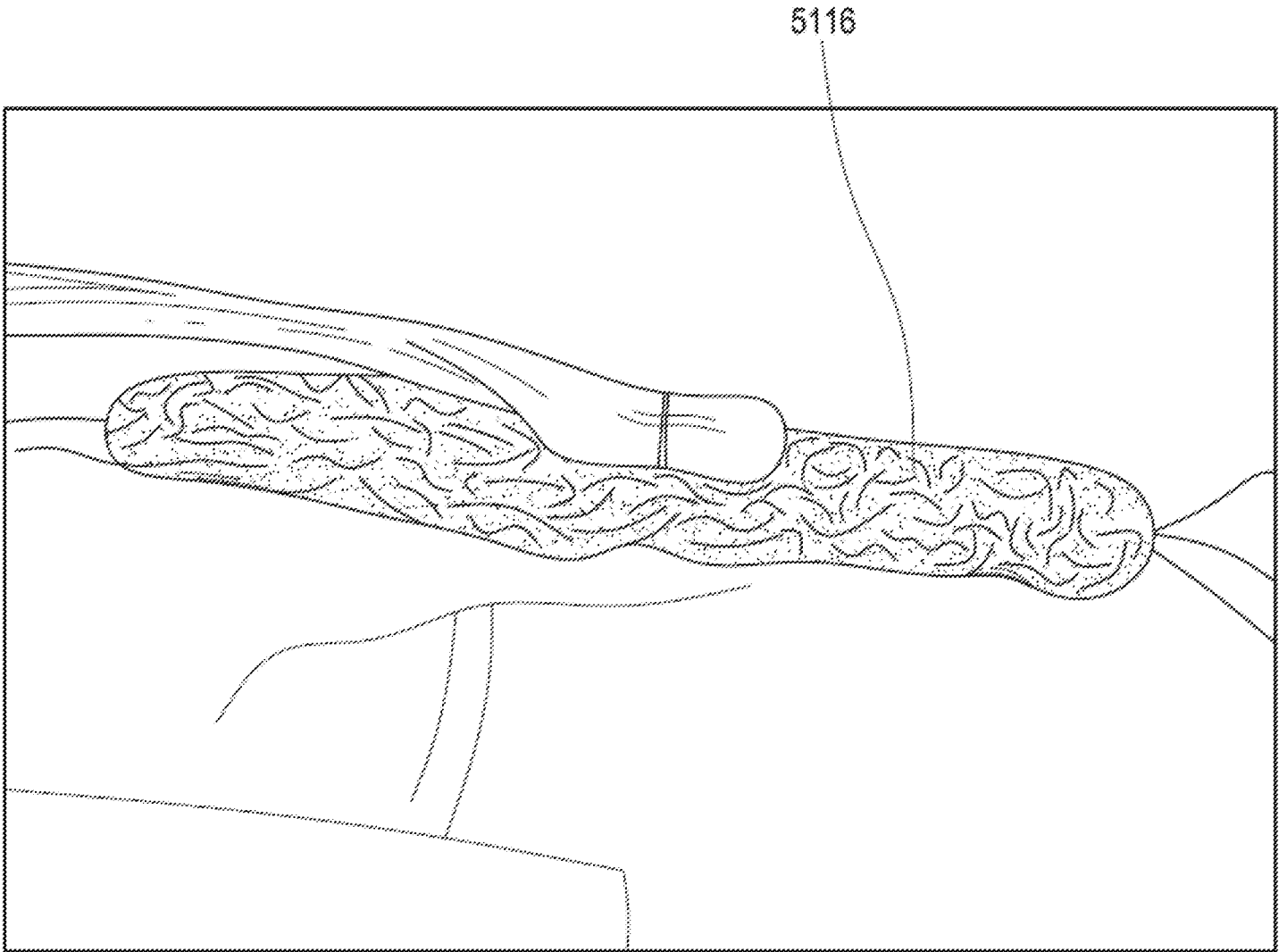

FIG. 15D

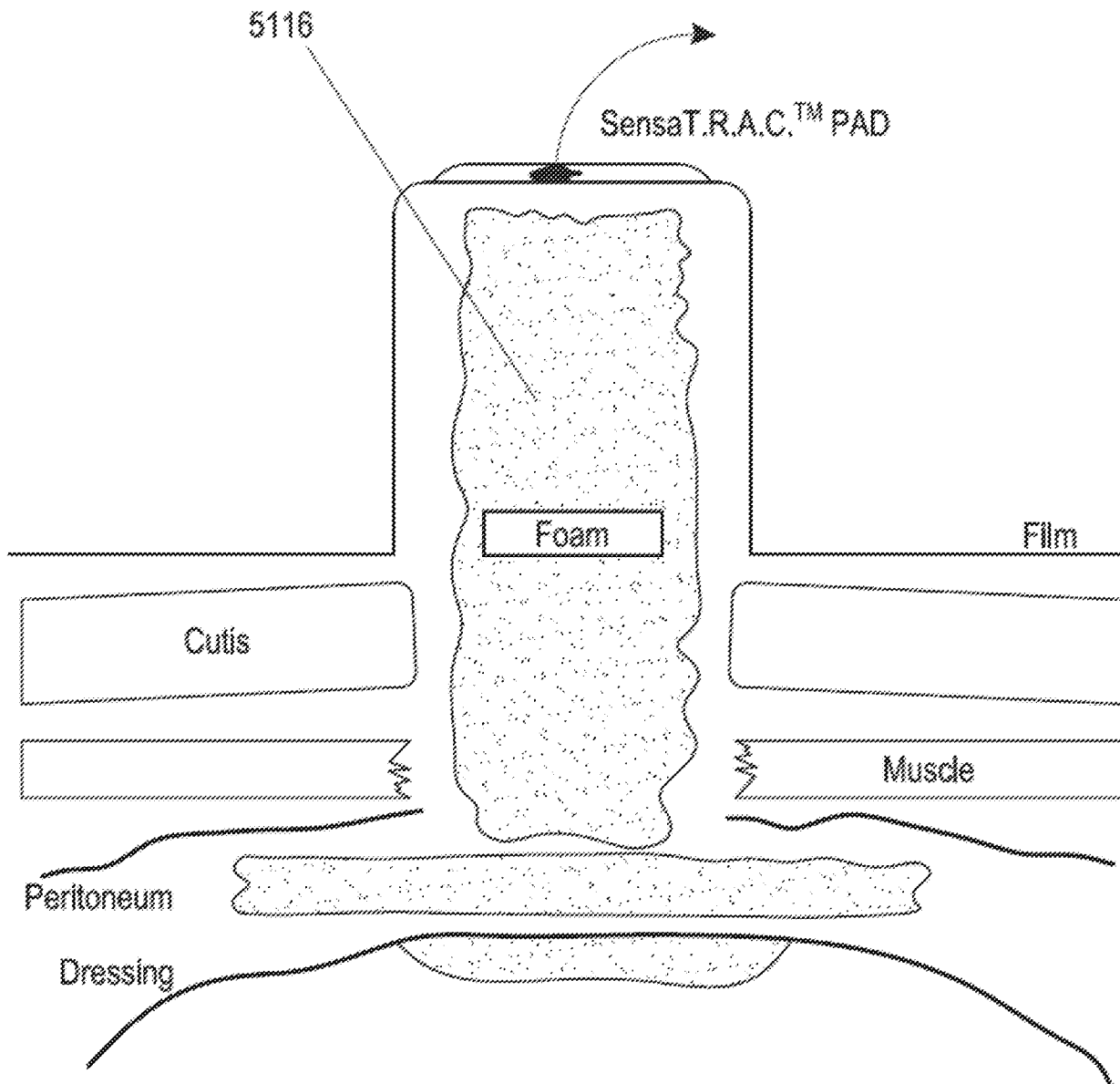

FIG. 15E