



US 20230093940A1

(19) **United States**

(12) **Patent Application Publication**  
**Castan et al.**

(10) **Pub. No.: US 2023/0093940 A1**

(43) **Pub. Date: Mar. 30, 2023**

(54) **BIOREACTOR WITH ADDITION TUBE**

*C12N 5/071* (2010.01)

(71) Applicant: **Cytiva Sweden AB**, Uppsala (SE)

*C12N 1/20* (2006.01)

(72) Inventors: **Andreas Castan**, Uppsala (SE); **Klaus Gebauer**, Uppsala (SE)

(52) **U.S. Cl.**

*C12N 5/04* (2006.01)

*C12N 1/16* (2006.01)

(21) Appl. No.: **18/062,481**

(22) Filed: **Dec. 6, 2022**

CPC ..... *C12M 29/00* (2013.01); *C12N 5/0601* (2013.01); *C12M 27/16* (2013.01); *C12M 21/08* (2013.01); *C12M 27/02* (2013.01); *C12N 5/0602* (2013.01); *C12M 23/26* (2013.01); *C12M 23/38* (2013.01); *C12M 29/14* (2013.01); *C12N 1/20* (2013.01); *C12N 5/04* (2013.01); *C12M 23/14* (2013.01); *C12N 1/16* (2013.01)

**Related U.S. Application Data**

(63) Continuation of application No. 14/910,824, filed on Feb. 8, 2016, now Pat. No. 11,549,091, filed as application No. PCT/SE2013/051001 on Aug. 27, 2013.

(57) **ABSTRACT**

**Publication Classification**

(51) **Int. Cl.**

*C12M 1/00* (2006.01)

*C12N 5/07* (2010.01)

*C12M 3/06* (2006.01)

*C12M 3/00* (2006.01)

*C12M 1/06* (2006.01)

The invention discloses a bioreactor with a vessel defining an inner volume, agitation means and at least one addition tube, wherein a delivery orifice in the addition tube is located within the inner volume and a check valve is arranged in proximity of the delivery orifice for allowing flow of a fluid in the direction from the addition tube into the inner volume of the vessel and blocking flow in the reverse direction.

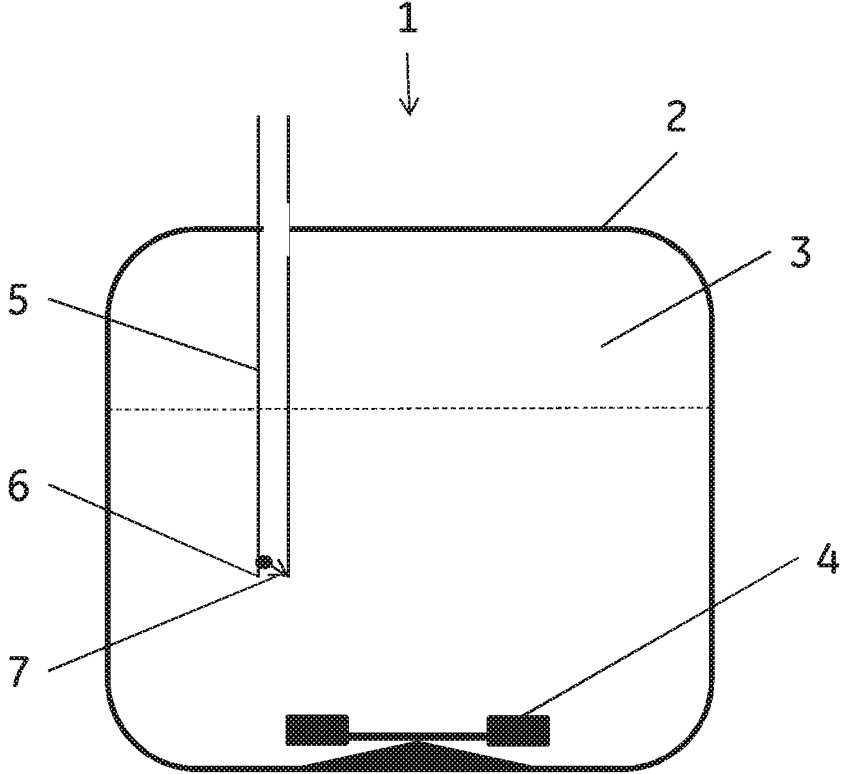

Fig. 1.

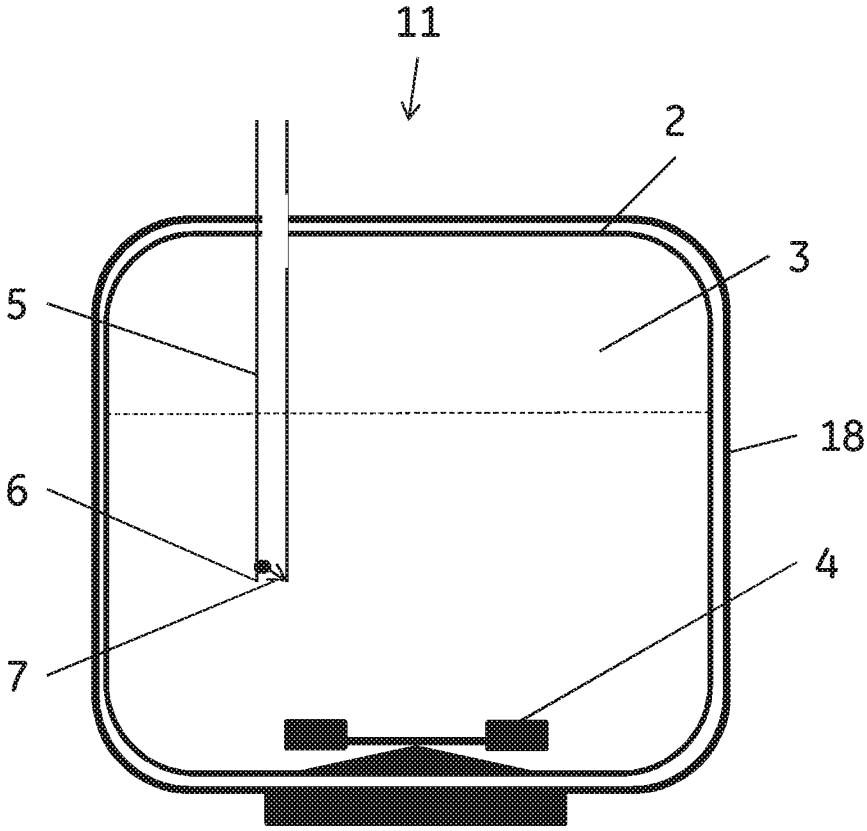

Fig. 2.

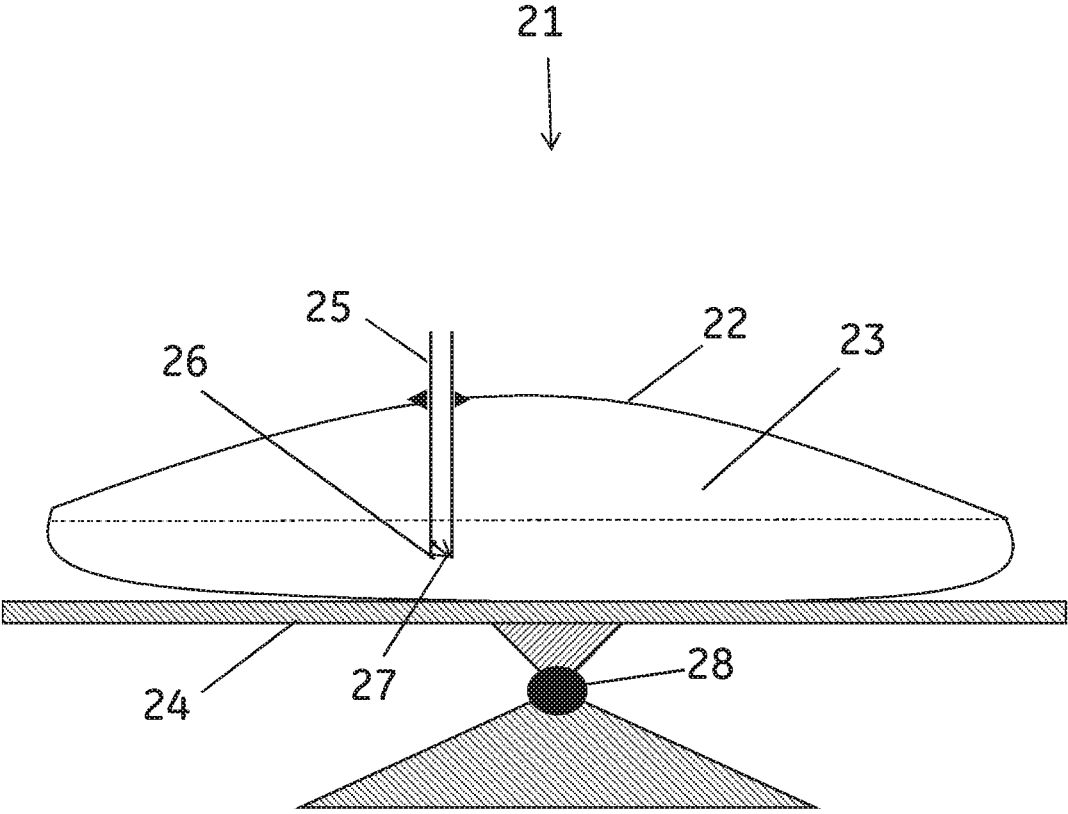

Fig. 3.

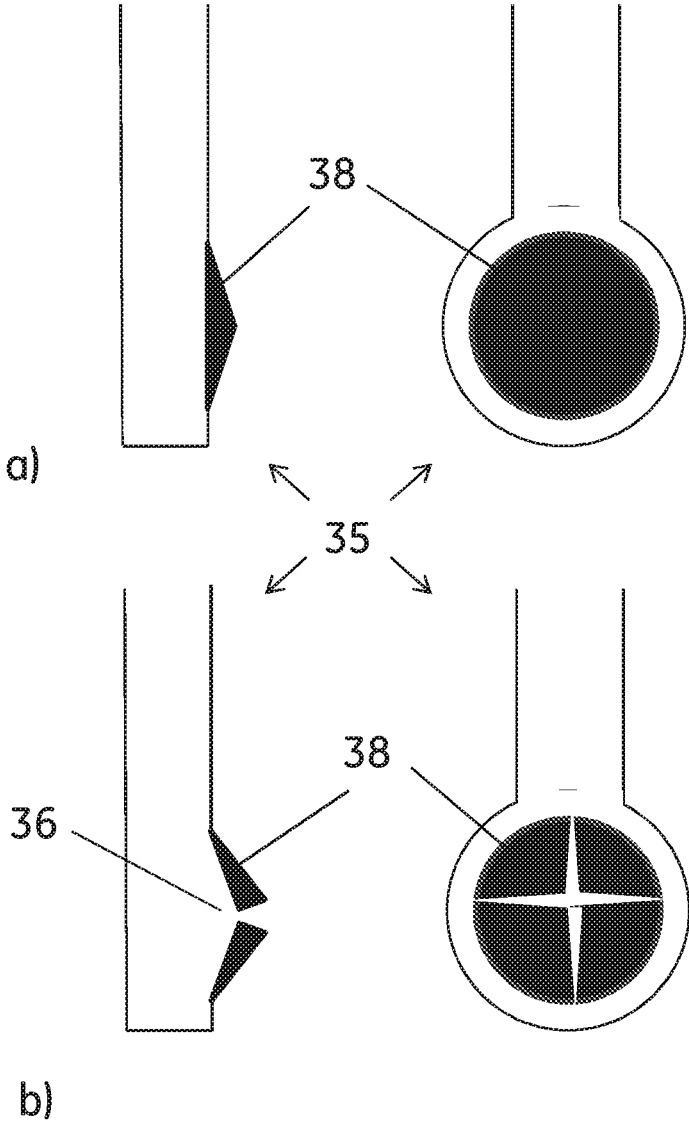

Fig. 4.

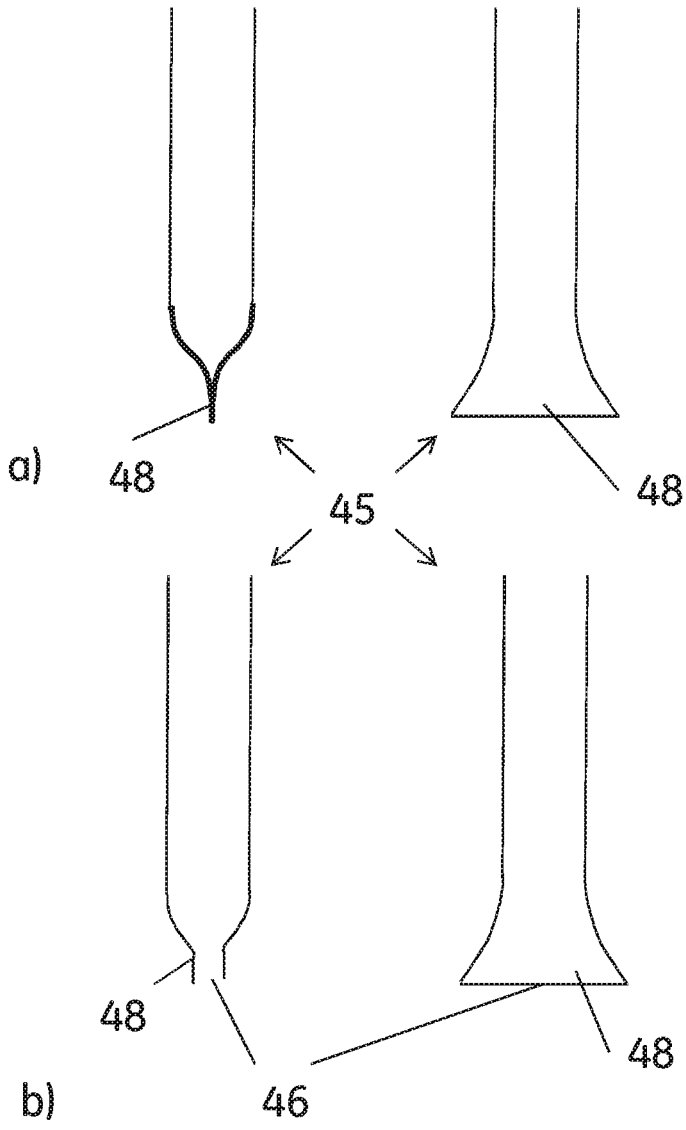

Fig. 5.

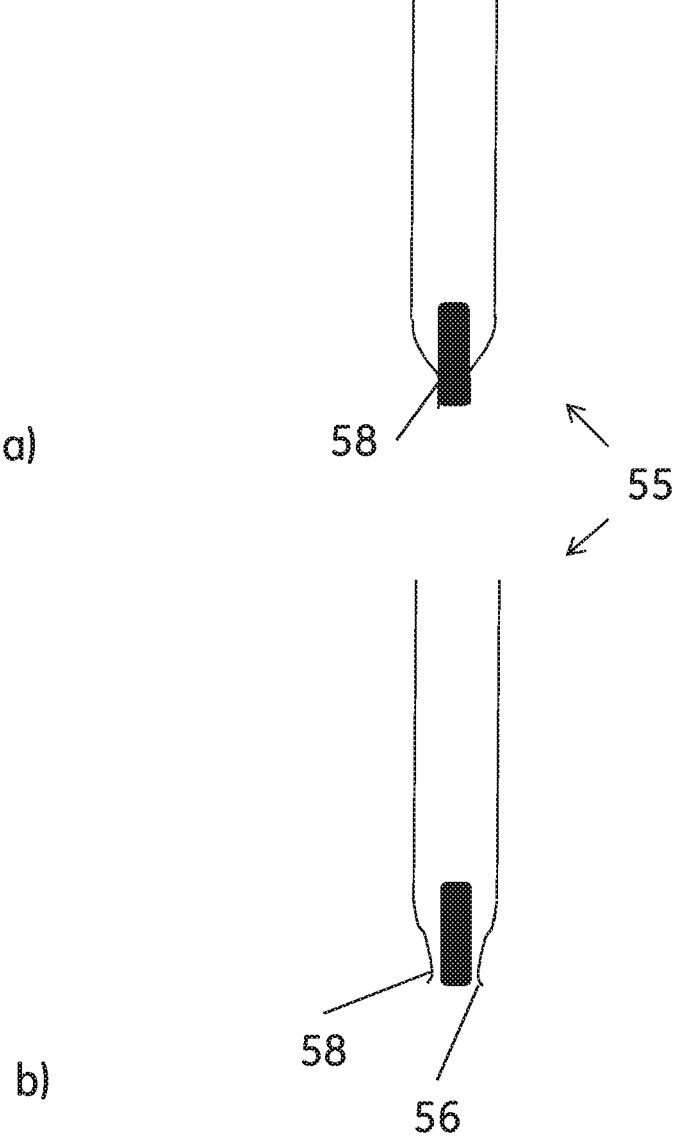

Fig. 6.

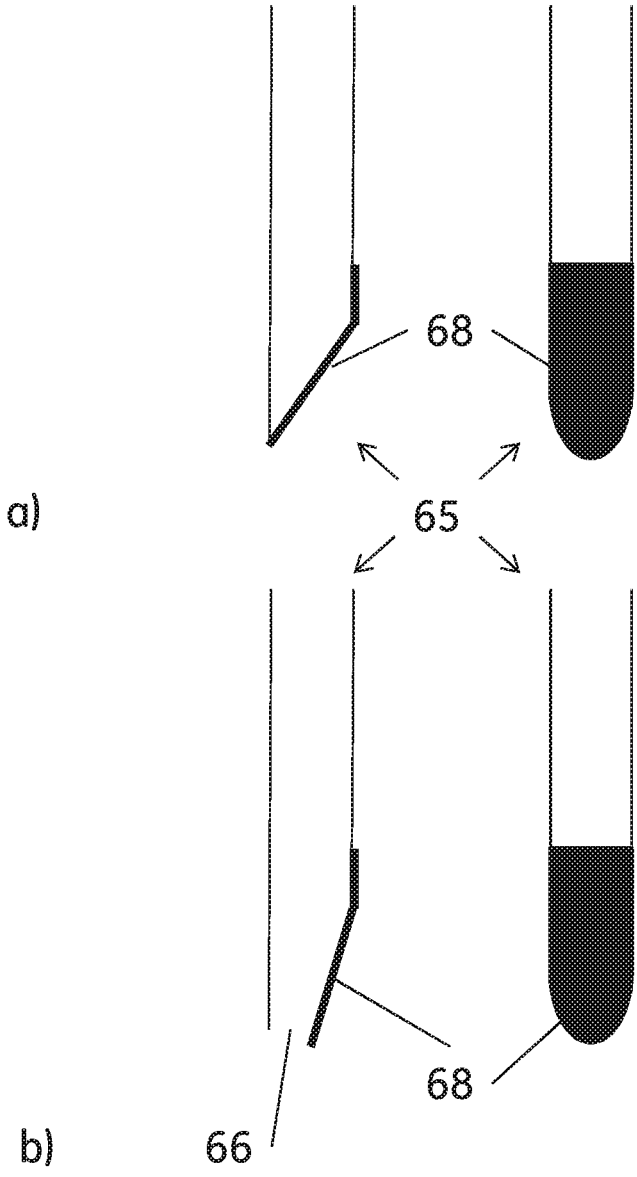

Fig. 7.



**BIOREACTOR WITH ADDITION TUBE****CROSS REFERENCE TO RELATED APPLICATIONS**

[0001] This application is a continuation of U.S. application Ser. No. 14/910,824, filed on Feb. 8, 2016, which claims the priority benefit of PCT/SE2013/051001, filed on Aug. 27, 2013. The entire contents of which are incorporated herein by reference.

**TECHNICAL FIELD OF THE INVENTION**

[0002] The present invention relates to bioreactors, and more particularly to addition tubes for bioreactors. The invention also relates to cultivation of cells in bioreactors with addition tubes.

**BACKGROUND OF THE INVENTION**

[0003] In the biopharmaceutical and Life Sciences industries, cells are commonly cultivated with the purpose either to recover products expressed by the cells, such as proteins, vaccine components etc. or to recover e.g. stem cells for therapeutic use. The cultivation conditions need to be carefully controlled and it is common practice to add reagents such as pH regulators, gases, nutrients, antifoam etc. to the culture during cultivation. This is done by pumping through an addition tube, which can have a delivery orifice (usually the end of the tube) either immersed in the cell culture medium or suspended above the cell culture medium. The pump is typically run intermittently, either controlled by a feedback loop or by a fixed addition program. One issue is then that reagent may be delivered by dripping or diffusion even when the pump is stopped, causing poor control of the reagent supply. When the delivery orifice is immersed, a further issue is also that cell culture medium and cells may enter the tube and be subjected to highly toxic conditions leading to cell death and release of detrimental signal substances. When the delivery orifice is suspended above the medium, the reagent may also go primarily into the foam layer on top of the medium, preventing proper distribution in the culture.

[0004] Accordingly there is a need for a well-controlled method of adding reagents to a cell culture with no risk of cells being subjected to overly high local reagent concentrations.

**SUMMARY OF THE INVENTION**

[0005] One aspect of the invention is to provide a means for well-controlled addition of reagents to cell cultures. This is achieved with a bioreactor as defined in claim 1.

[0006] One advantage is that reagents are only delivered when intended and in the amounts intended. Further advantages are that the reagents are evenly distributed and that cells are not exposed locally to high transient reagent concentrations.

[0007] Another aspect of the invention is to provide a method of cultivating cells with well-controlled addition of reagents. This is achieved with a cell cultivation method as defined in the claims.

[0008] Further suitable embodiments of the invention are described in the dependent claims.

**BRIEF DESCRIPTION OF THE DRAWINGS**

[0009] FIG. 1 shows a bioreactor according to the invention.

[0010] FIG. 2 shows a bioreactor according to the invention, with a plastic bag supported by a rigid structure.

[0011] FIG. 3 shows a bioreactor according to the invention, with an inflatable bag resting on a movable platform.

[0012] FIG. 4 shows a detailed picture of an addition tube of the invention, with a split disk check valve.

[0013] FIG. 5 shows a detailed picture of an addition tube of the invention, with a lip (duckbill) check valve.

[0014] FIG. 6 shows a detailed picture of an addition tube of the invention, with a tubular check valve.

[0015] FIG. 7 shows a detailed picture of an addition tube of the invention, with a flap check valve.

**DETAILED DESCRIPTION OF EMBODIMENTS**

[0016] In one aspect the present invention discloses a bioreactor 1;11;21 comprising a vessel 2;22 which defines an inner volume 3;23. The bioreactor further comprises agitation means 4;24 and at least one addition tube 5;25, where a delivery orifice 6;26 in the addition tube is located within the inner volume of the vessel and a check valve 7;27 is arranged in proximity of, or adjacent, the delivery orifice such that it allows flow of a fluid in the direction from the addition tube into the inner volume 3;23 and blocking flow in the reverse direction. When check valve 7;27 is arranged in proximity of delivery orifice 6;26, the distance between the check valve and the orifice may be e.g. up to 20 times the diameter of tube 5;25, such as up to 10 times, up to 5 times or up to 2 times the diameter of tube 5;25 (or the average diameter if the diameter varies along the length of tube 5;25). Short distances are advantageous due to the smaller dead volumes, but it can be easier to accommodate the check valve in the tube if some distance is allowed. When a fluid, such as a pH regulating solution, a nutrient solution, a growth factor solution or a gas is supplied to the inner volume via the addition tube and the delivery orifice, the check valve opens and when no fluid is supplied the valve is closed, blocking any convective or diffusive permeation of fluid from the inner volume into the addition tube. The vessel can typically have a volume from 0.1 litres up to several thousand litres and the diameter of the addition tube can correspondingly be from about 1 mm up to several cm. The addition tube can be connected with a port in a wall of the vessel and this port can during use of the bioreactor be connected, e.g. with tubing, to a fluid supply vessel and to a pressure-generating delivery means. The delivery means can e.g. be a pump, a pressurized fluid supply vessel or a fluid supply vessel placed above the bioreactor to generate a hydrostatic pressure. The delivery of fluid can be controlled e.g. by switching or regulating a pump or by opening/closing a regulator valve in the tubing.

[0017] In some embodiments, the delivery orifice 6;26 of the addition tube is arranged to be immersed in liquid during use of the bioreactor. This has the advantage that the fluid is added directly into the cell culture liquid and there is no risk of fluid being trapped in the foam layer formed on top of the liquid during cultivation. The addition tube can e.g. be connected with a port in a top wall of the vessel and the addition tube can have a length sufficient to reach down at least halfway to a bottom wall of the vessel, such as at least 80% or at least 90% of the distance from the top wall to the

bottom wall, with the delivery orifice located at or in proximity of a bottom end of the addition tube. The bioreactor should in these cases be supplied with an instruction to fill the vessel with sufficient liquid for immersion of the delivery orifice during use. The addition tube can alternatively also be connected with a port in a side wall or a bottom wall of the vessel and even in these cases the vessel should be filled with sufficient liquid for immersion of the delivery orifice during use.

**[0018]** In certain embodiments, the position of the delivery orifice in the vessel is adjustable. This can be achieved e.g. with a telescopic addition tube, bellows in a vessel wall port to which the addition tube is connected, etc. and has the advantage that the delivery orifice can be immersed and positioned at a point of high turbulence regardless of the degree of filling of the vessel.

**[0019]** In some embodiments, the delivery orifice **6;26** of the addition tube is covered by the check valve **7;27**. An advantage of this is that the cell culture liquid is in direct contact with the check valve and no stagnant zones are formed outside the check valve. The check valve itself can suitably be constructed such that no stagnant zones are formed on its outside. Examples of such check valves are illustrated in FIGS. **4-7**.

**[0020]** In some embodiments, the check valve is inserted in the addition tube, e.g. at a position in proximity of the delivery orifice.

**[0021]** In certain embodiments, the opening pressure of said check valve is below or equal to 10 kPa, such as between 10 Pa and 10 kPa, between 100 Pa and 10 kPa or between 1 kPa and 10 kPa. A too high opening pressure can give rise to pressure build-up and uncontrolled burst of fluid, while a too low opening pressure may cause the valve to open e.g. from pressure fluctuations induced by the agitation. The opening pressure is the minimum pressure difference between the two sides (inlet side and outlet side) of the check valve, which will cause the check valve to open. It can easily be determined with standard method, e.g. by gradually increasing the pressure on the inlet side and noting at which pressure the valve opens.

**[0022]** In some embodiments, the check valve comprises an elastomeric closing member **38;48;58;68**. Elastomeric closing members facilitate the construction of check valves without stagnant zones and are well compatible with single use bioreactor vessels. It is also possible to have an addition tube with an integrally formed elastomeric check valve closing member, such that no separate assembly of valve parts is needed.

**[0023]** In certain embodiments, the elastomeric closing member is selected from the group consisting of tubes, lips, flaps and split disks. An example of a tubular closing member **58** is shown in FIG. **6**, an example of lips **48** in FIG. **5**, a flap **68** in FIG. **7** and a split disk **38** in FIG. **4**. All these constructions can be made with no or minimal outside stagnant zones and they are suitable for use in bioreactors.

**[0024]** In some embodiments, the vessel comprises a flexible plastic bag **2;22**. This allows for single use bioreactors. The flexible plastic bag **2** can e.g. be supported by a rigid support structure **18** during use. The rigid support structure can be made from e.g. stainless steel.

**[0025]** In certain embodiments the agitation means comprises an impeller **4**. The impeller is suitably located in the inner volume of the vessel and can be arranged to rotate or oscillate, e.g. by the action of an external magnetic drive.

**[0026]** In some embodiments the flexible plastic bag **22** is inflatable and the agitation means comprises a movable support platform **24** for the flexible plastic bag. As illustrated in FIG. **3**, the inflated bag can be self-supporting and can rest on the platform **24**, which can be movable around an axis **28** to generate an oscillatory rocking agitation.

**[0027]** In certain embodiments the bioreactor or the vessel, including the addition tube and optionally the agitation means, is radiation sterilized. This is convenient for single-use bioreactors and can be achieved when all the components are made from radiation stable materials. Suitable materials for the vessel and the addition tube can be e.g. polyethylene and ethylene copolymers, while suitable elastomers for the closing member of the check valve can be e.g. radiation stable silicones.

**[0028]** In some embodiments the addition tube is fluidically connected to a supply vessel containing a liquid solution comprising a pH regulator, a nutrient and/or a growth factor. The liquid solution can be e.g. aqueous ammonia for pH control, but it can also be more complex media component solutions.

**[0029]** In one aspect the present invention discloses a method of cell cultivation, which comprises the steps of:

**[0030]** a) providing a bioreactor as described above;

**[0031]** b) adding cell cultivation medium and cells to the inner volume of the vessel;

**[0032]** c) providing agitation by the agitation means, and

**[0033]** d) adding a liquid solution and/or a gas to the inner volume via the addition tube.

**[0034]** The cells can be e.g. i) animal cells, such as mammalian or insect cells, ii) microorganisms such as bacteria or yeast cells or iii) plant cells.

**[0035]** In certain embodiments the amount of cell cultivation medium in step b) is sufficient to immerse the delivery orifice of the addition tube.

**[0036]** In some embodiments the liquid solution comprises a pH regulator, a nutrient and/or a growth factor.

**[0037]** This written description uses examples to disclose the invention, including the best mode, and also to enable any person skilled in the art to practice the invention, including making and using any devices or systems and performing any incorporated methods. The patentable scope of the invention is defined by the claims, and may include other examples that occur to those skilled in the art. Such other examples are intended to be within the scope of the claims if they have structural elements that do not differ from the literal language of the claims, or if they include equivalent structural elements with insubstantial differences from the literal languages of the claims. Features from different embodiments may be combined to form new embodiments.

**1.** A bioreactor comprising:

a vessel defining an inner volume configured to contain liquid contents;

an agitation means;

at least one addition tube configured to introduce reagents from outside the bioreactor, the at least one addition tube having a first end protruding into the inner volume of the vessel to be in direct contact with the liquid contents of the vessel wherein cultivation takes place and a second end residing outside of the bioreactor; and

a check valve having a delivery orifice adjacent the first end of the at least one addition tube, with the delivery orifice configured to be immersed in direct contact with

the liquid contents of the vessel wherein cultivation takes place, the check valve comprising a closing member covering the delivery orifice allowing flow of a fluid in a downward direction along gravity from the second end, through the addition tube and through the delivery orifice into the inner volume of the vessel and blocking flow in the reverse direction, wherein there is no or minimal stagnant zones outside the check valve.

2. The bioreactor of claim 1, wherein the check valve has an opening pressure of between 10 Pa and 10 kPa.

3. The bioreactor of claim 1, wherein the closing member is elastomeric.

4. The bioreactor of claim 3, wherein the elastomeric closing member is selected from the group consisting of tubes, lips, flaps and split disks.

5. The bioreactor of claim 1, wherein the vessel comprises a flexible plastic bag.

6. The bioreactor of claim 5, wherein the flexible plastic bag is arranged to be supported by a rigid support structure during use.

7. The bioreactor of claim 1, wherein the agitation means comprises an impeller.

8. The bioreactor of claim 5, wherein the flexible plastic bag is inflatable and the agitation means comprises a movable support platform for the flexible plastic bag.

9. The bioreactor of claim 1, wherein the addition tube is fluidically connected to a supply vessel containing a liquid solution comprising a pH regulator, a nutrient and/or a growth factor.

10. The bioreactor of claim 1, wherein the check valve has an opening pressure of between 100 Pa and 10 kPa.

11. A bioreactor comprising,

a vessel defining an inner volume configured to contain liquid contents;

an agitation means;

at least one addition tube configured to introduce reagents from outside the bioreactor, the at least one addition tube having a first end protruding into the inner volume

of the vessel to be in direct contact with the liquid contents of the vessel wherein cultivation takes place; and

a check valve having a delivery orifice adjacent the first end of the at least one addition tube, with the delivery orifice configured to be immersed in direct contact with the liquid contents of the vessel wherein cultivation takes place, for allowing flow of a fluid in a downward direction along gravity from the addition tube into the inner volume through the delivery orifice and blocking flow in the reverse direction, such that there is no or minimal stagnant zones outside the check valve.

12. The bioreactor of claim 11, wherein the at least one addition tube is further configured such that the first end protruding into the inner volume of the vessel is located near a bottom of the vessel.

13. The bioreactor of claim 11, wherein the check valve has an opening pressure of between 10 Pa and 10 kPa.

14. The bioreactor of claim 11, wherein the check valve comprises an elastomeric closing member selected from the group consisting of tubes, lips, flaps and split disks.

15. The bioreactor of claim 11, wherein the vessel comprises a flexible plastic bag.

16. The bioreactor of claim 15, wherein the flexible plastic bag is arranged to be supported by a rigid support structure during use.

17. The bioreactor of claim 11, wherein the agitation means comprises an impeller.

18. The bioreactor of claim 15, wherein the flexible plastic bag is inflatable and the agitation means comprises a movable support platform for the flexible plastic bag.

19. The bioreactor of claim 11, wherein the addition tube is fluidically connected to a supply vessel containing a liquid solution comprising a pH regulator, a nutrient and/or a growth factor.

20. The bioreactor of claim 11, wherein the check valve has an opening pressure of between 100 Pa and 10 kPa.

\* \* \* \* \*