



US 20240122364A1

(19) **United States**

(12) **Patent Application Publication**
LENG

(10) **Pub. No.: US 2024/0122364 A1**

(43) **Pub. Date: Apr. 18, 2024**

(54) **SPRING MODULE AND SPRING CUSHION FOR FURNITURE**

Publication Classification

(71) Applicant: **NEW-TEC INTEGRATION (XIAMEN) CO., LTD.**, Xiamen (CN)

(51) **Int. Cl.**
A47C 27/07 (2006.01)
A47C 27/06 (2006.01)

(72) Inventor: **Luhao LENG**, Xiamen (CN)

(52) **U.S. Cl.**
CPC *A47C 27/07* (2013.01); *A47C 27/063* (2013.01); *A47C 27/065* (2013.01)

(21) Appl. No.: **17/769,235**

(22) PCT Filed: **Oct. 16, 2020**

(57) **ABSTRACT**

(86) PCT No.: **PCT/CN2020/121418**

§ 371 (c)(1),

(2) Date: **Apr. 14, 2022**

The present disclosure provides a spring module for a spring cushion of furniture and a spring cushion having the same, the spring module may comprise a spring and a spring bracket for accommodating the conical spring, and the spring bracket may comprise a base, an end cover and a flexible connecting part connected therebetween, the spring may be fixed in the spring bracket with a predetermined initial pressure. The present disclosure further relates to a spring cushion having the spring module.

(30) **Foreign Application Priority Data**

Oct. 17, 2019 (CN) 201910990436.2

Oct. 15, 2020 (CN) 202011104573.0

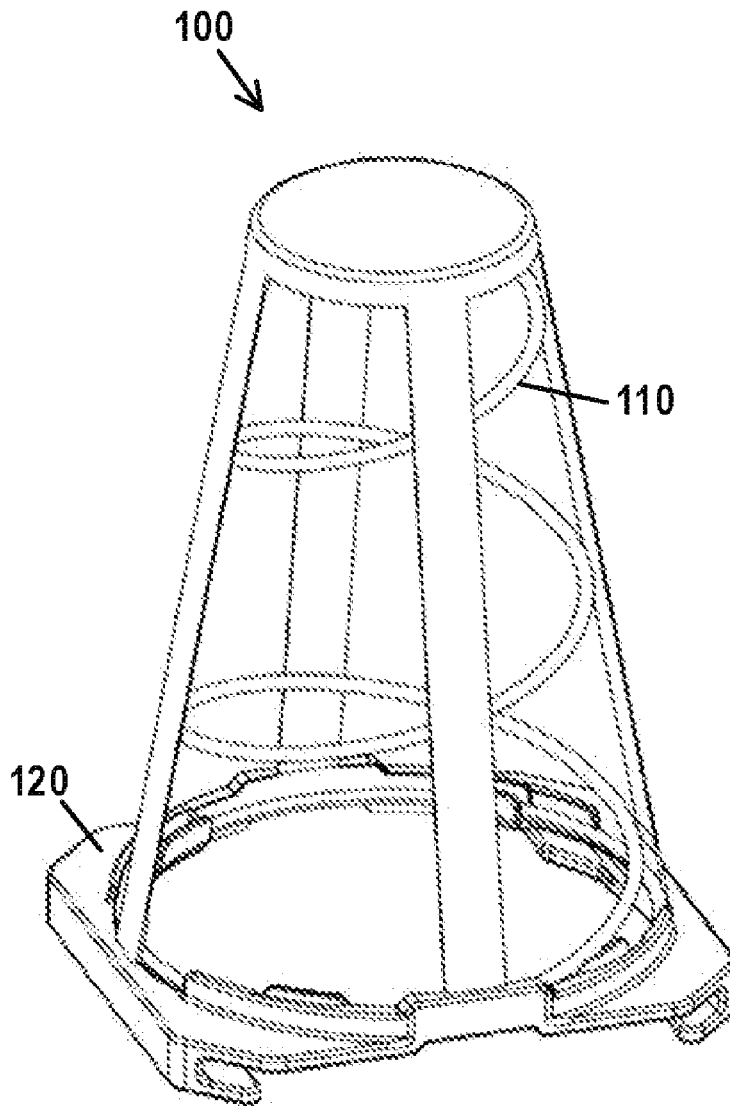

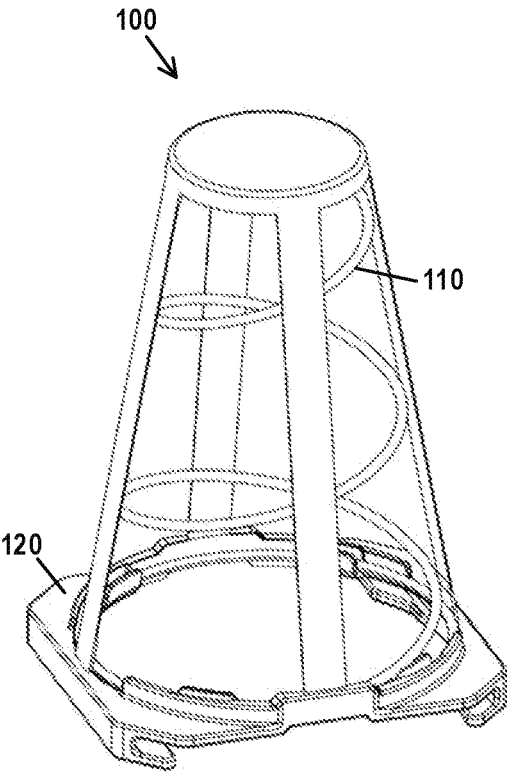

FIG.1A

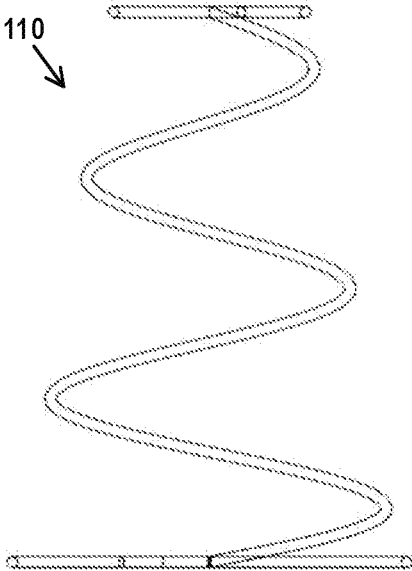

FIG.1B

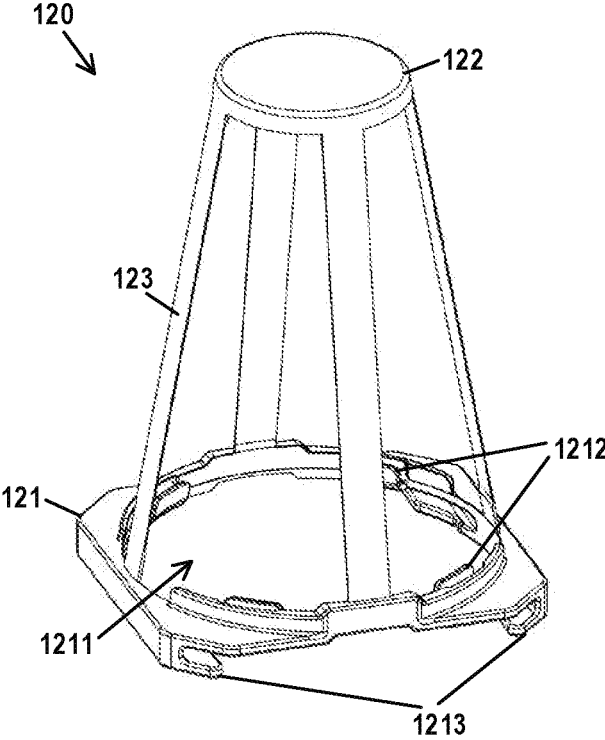

FIG.1C

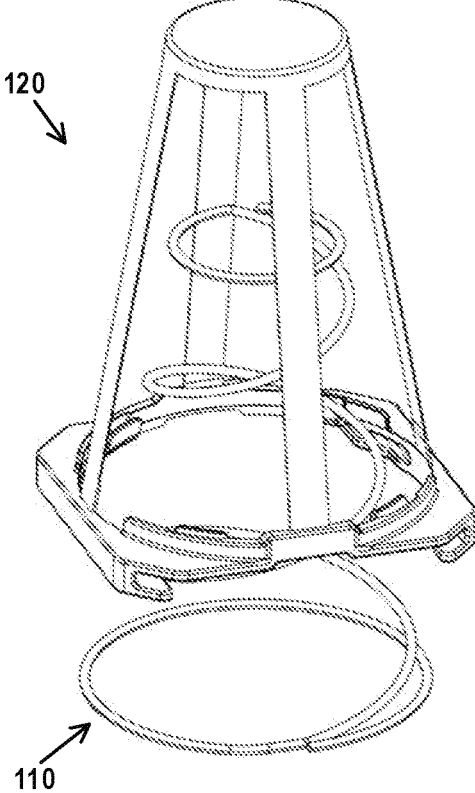

FIG.1D

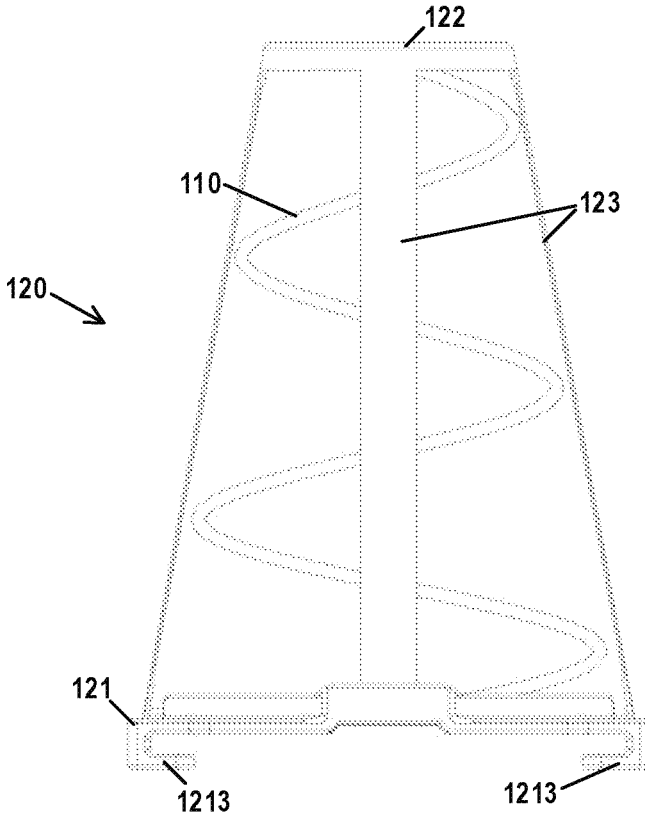

FIG.1E

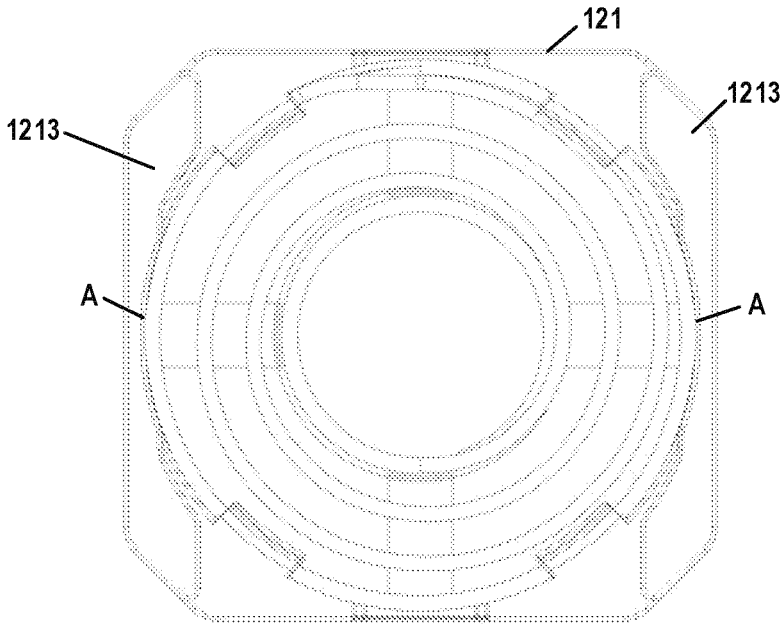

FIG.1F

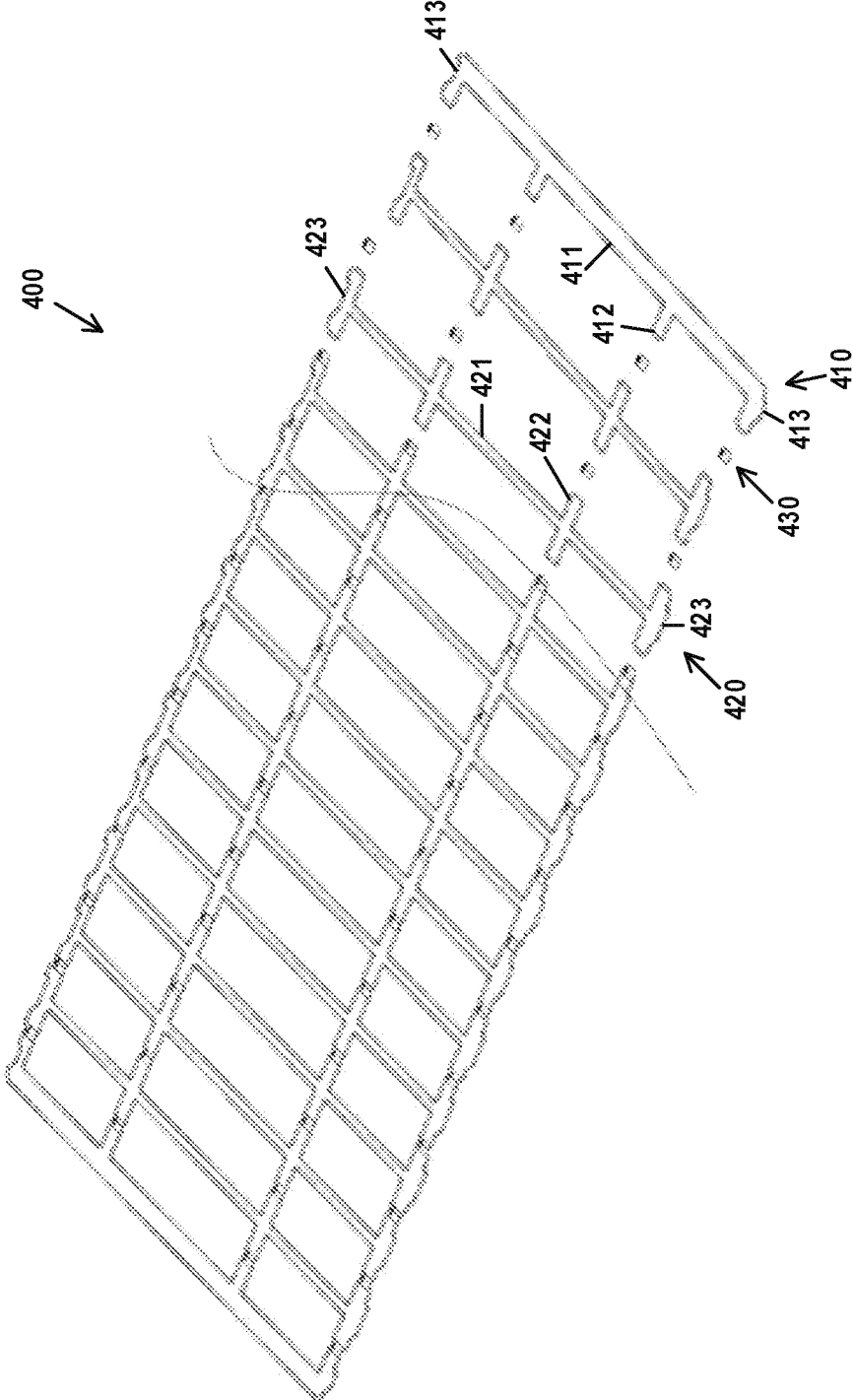

FIG. 2

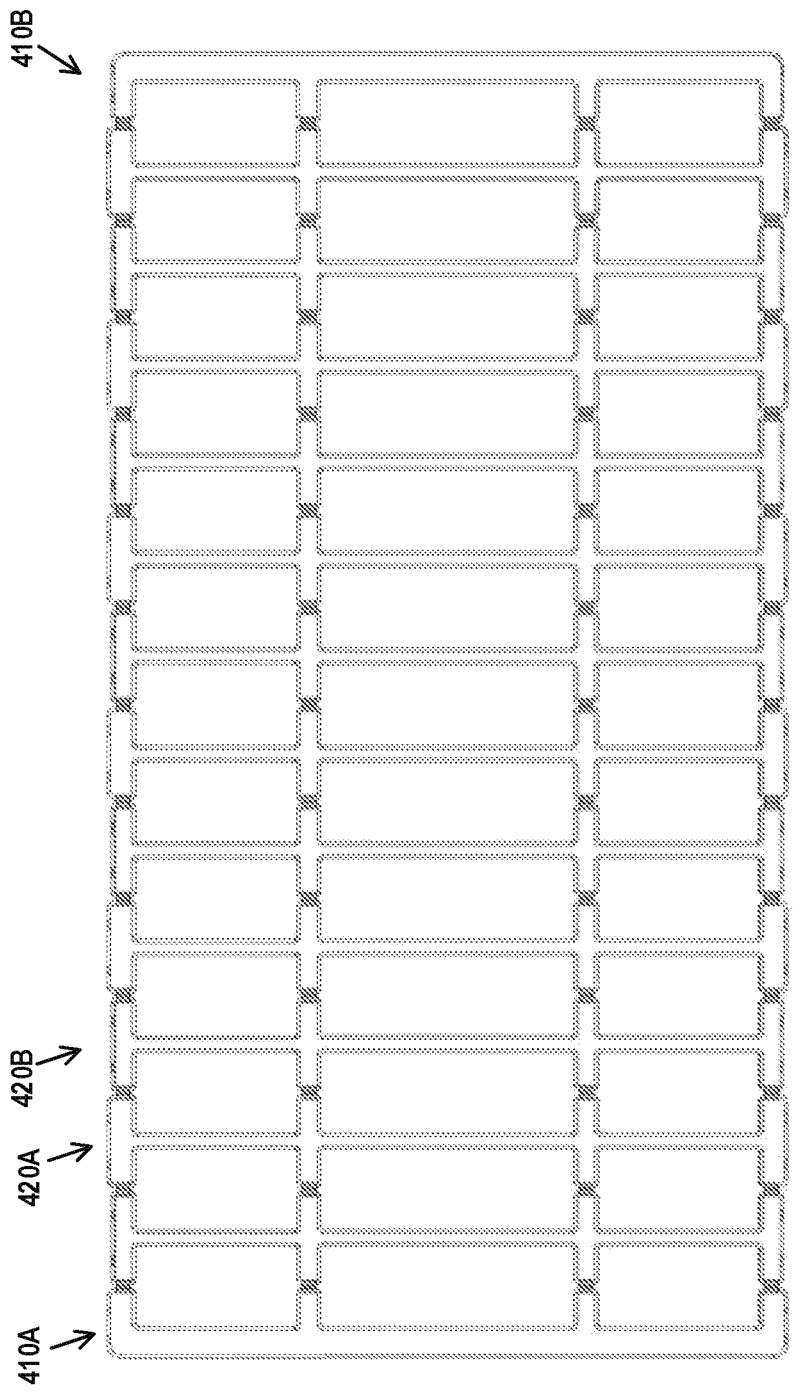

FIG. 3A



FIG. 3B

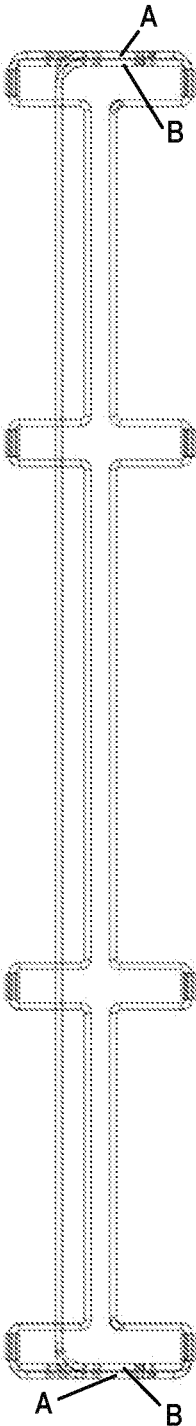

FIG.3C

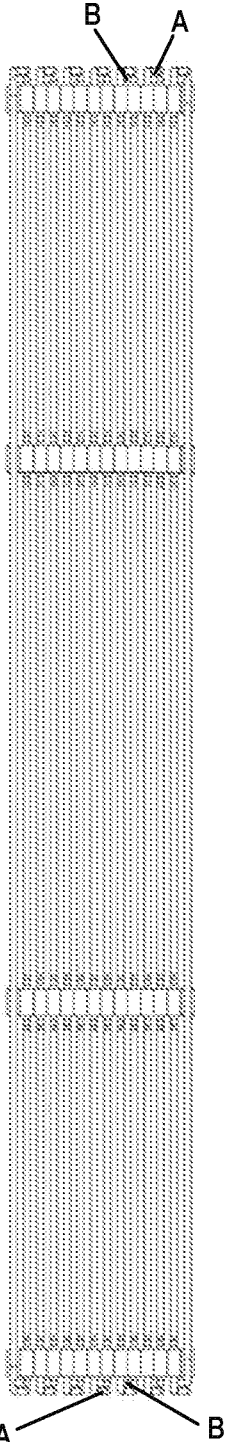

FIG.3D

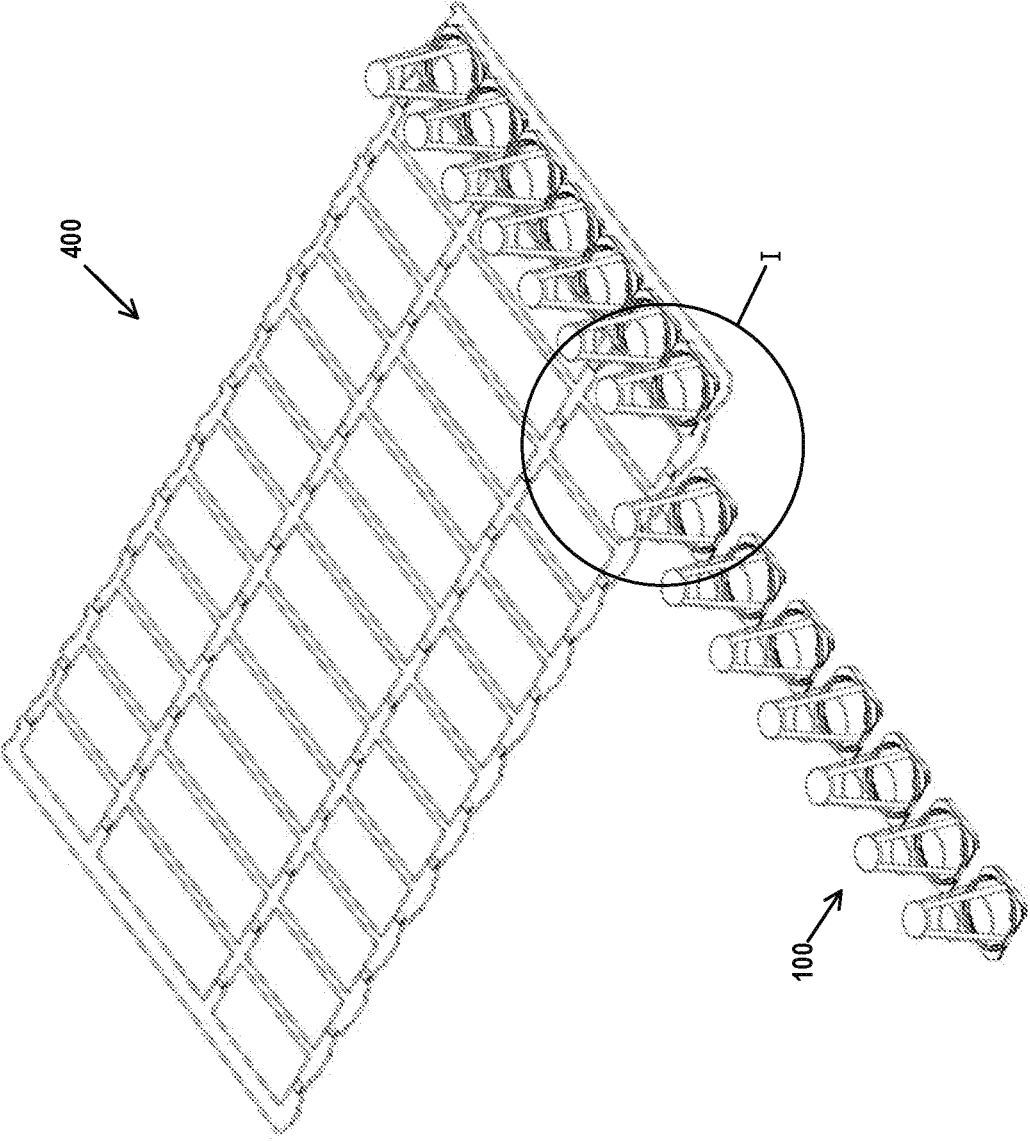

FIG.4A

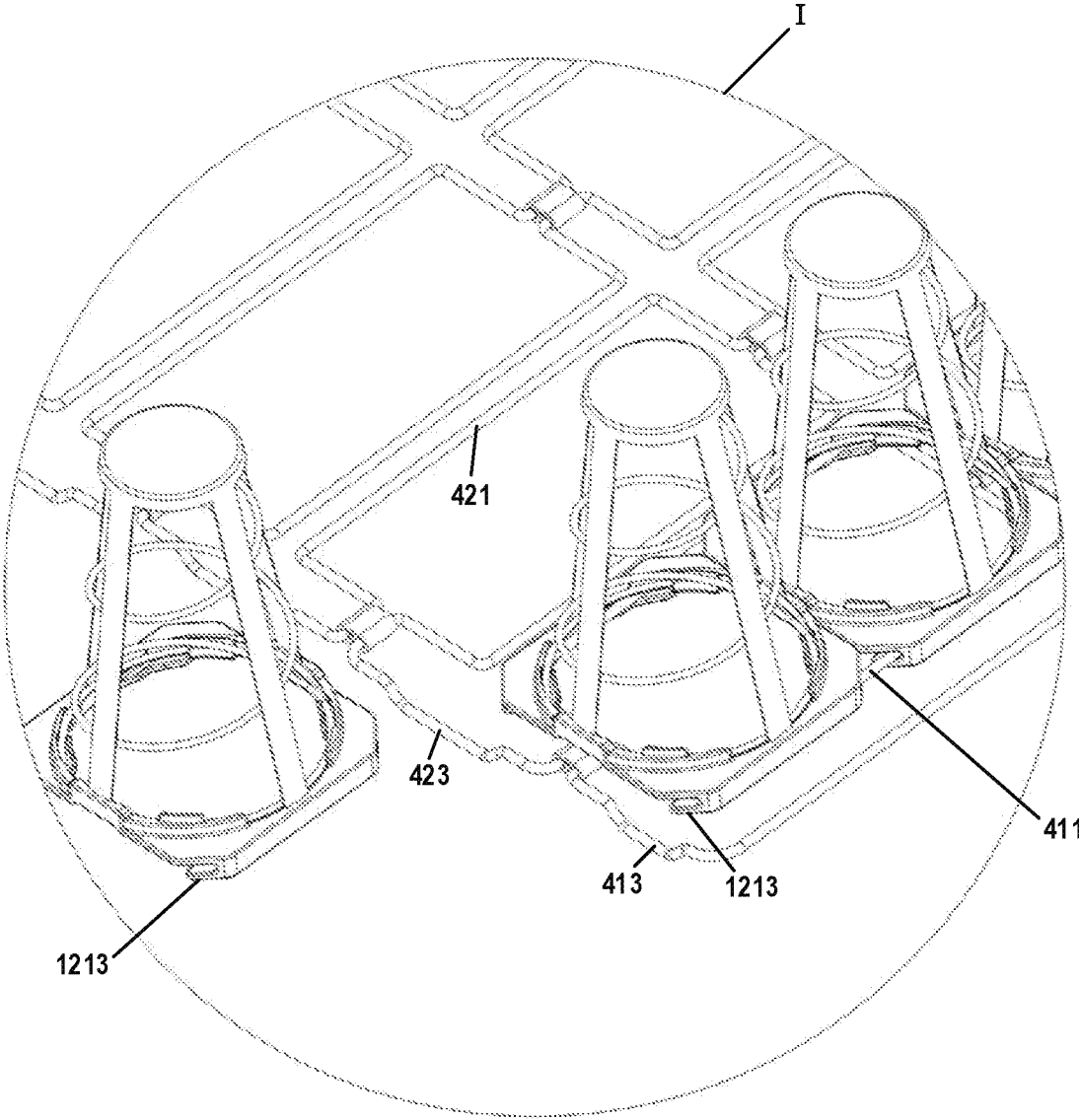

FIG.4B

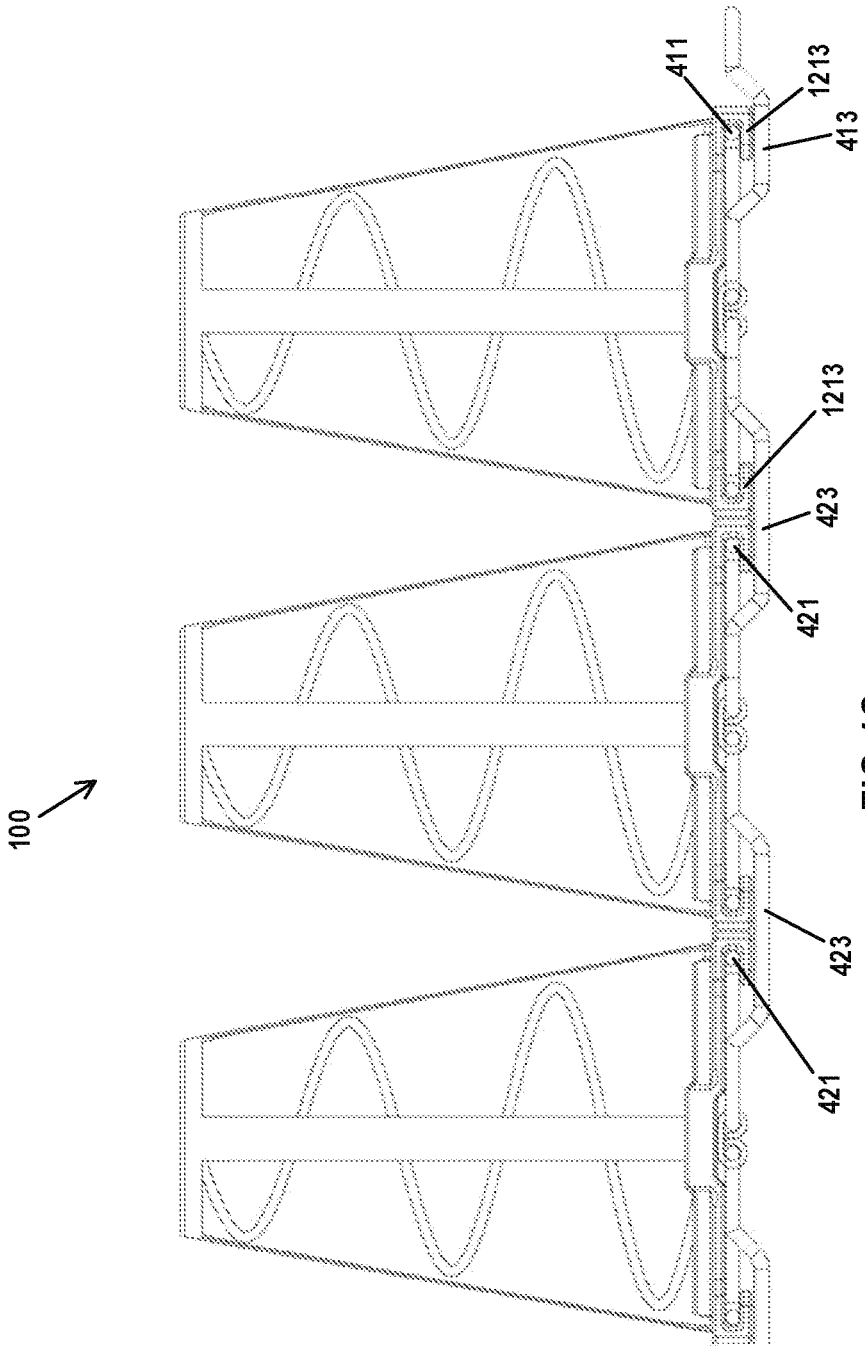

FIG.4C

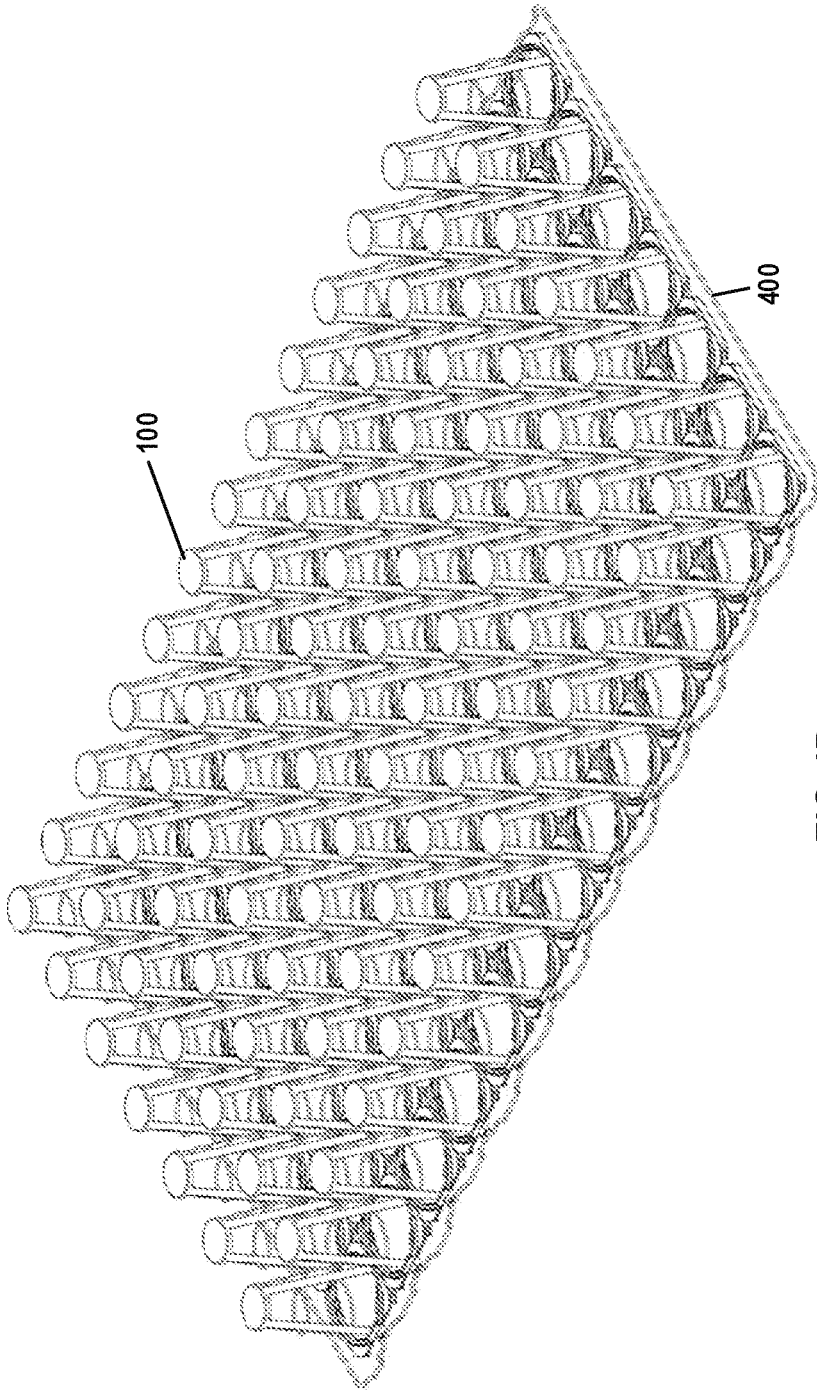

FIG.4D

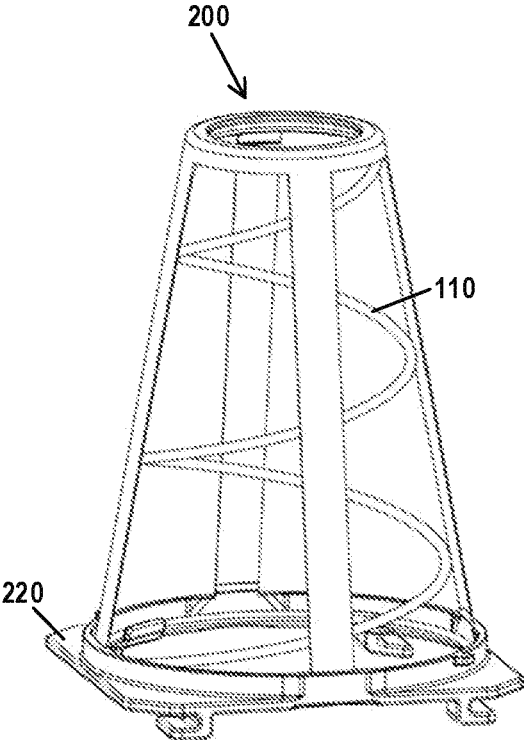

FIG. 5A

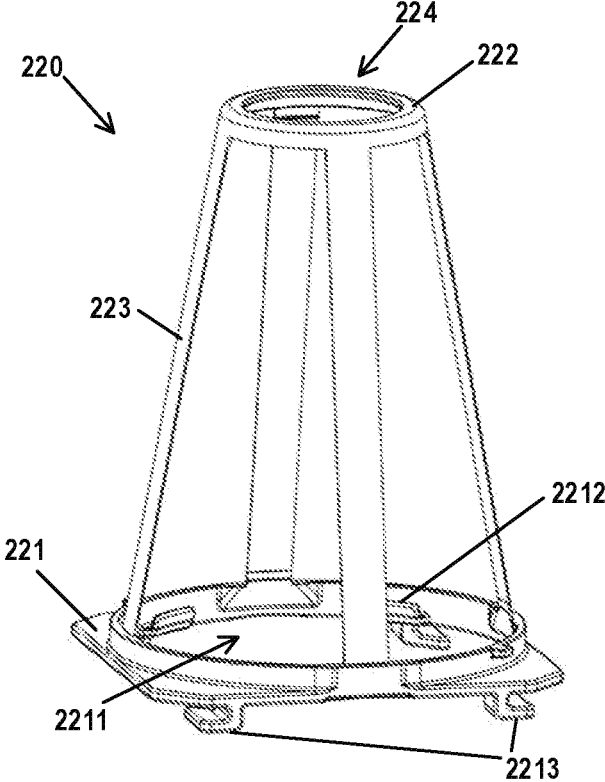

FIG. 5B

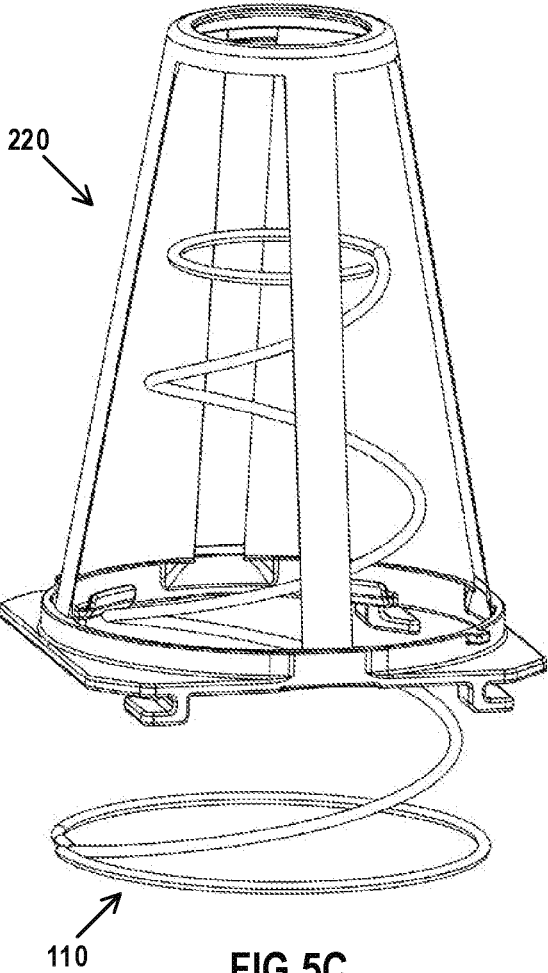

FIG.5C

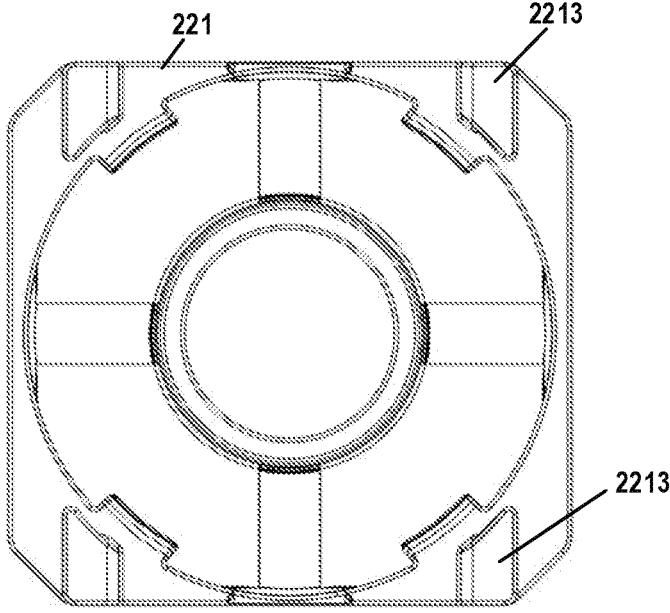

FIG.5D

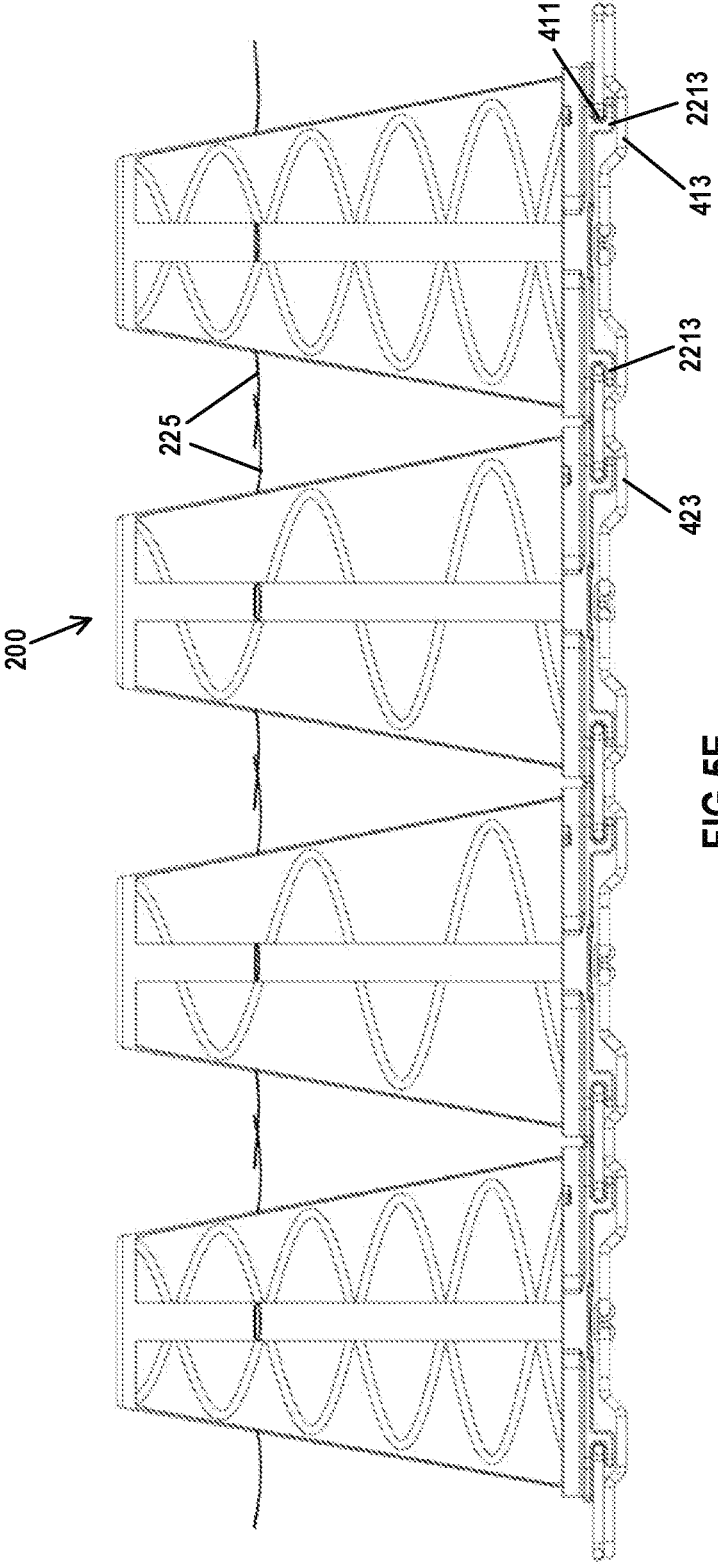

FIG.5E

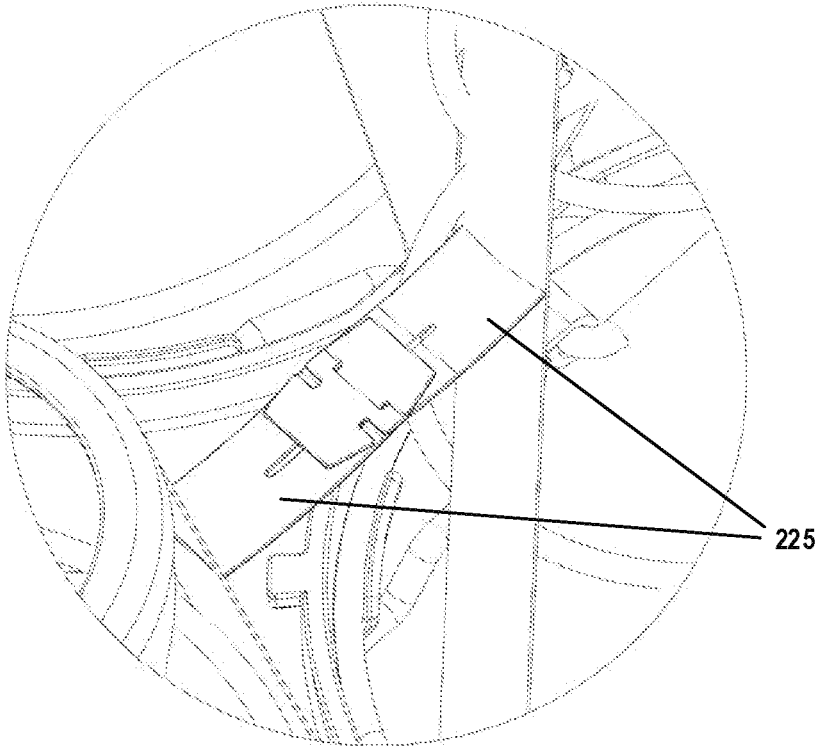

FIG. 5F

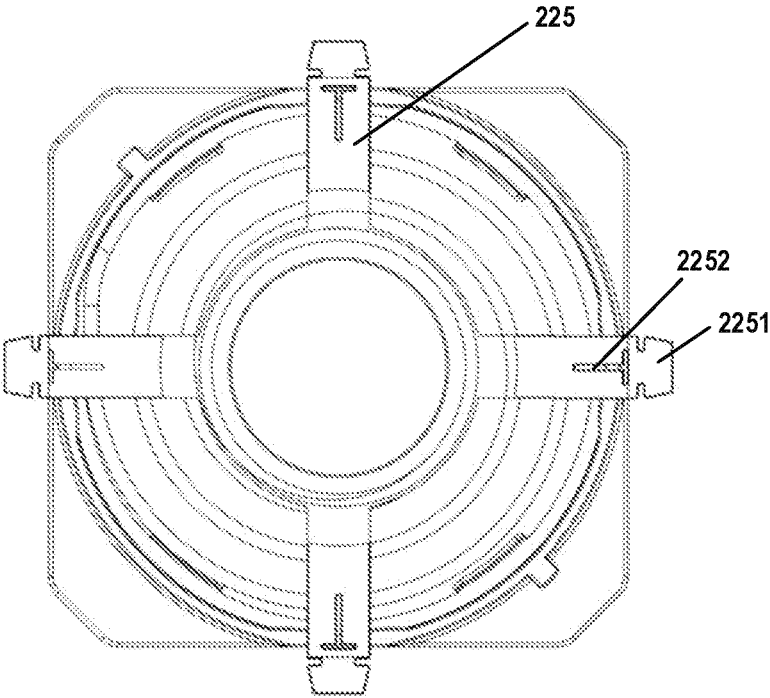

FIG. 5G

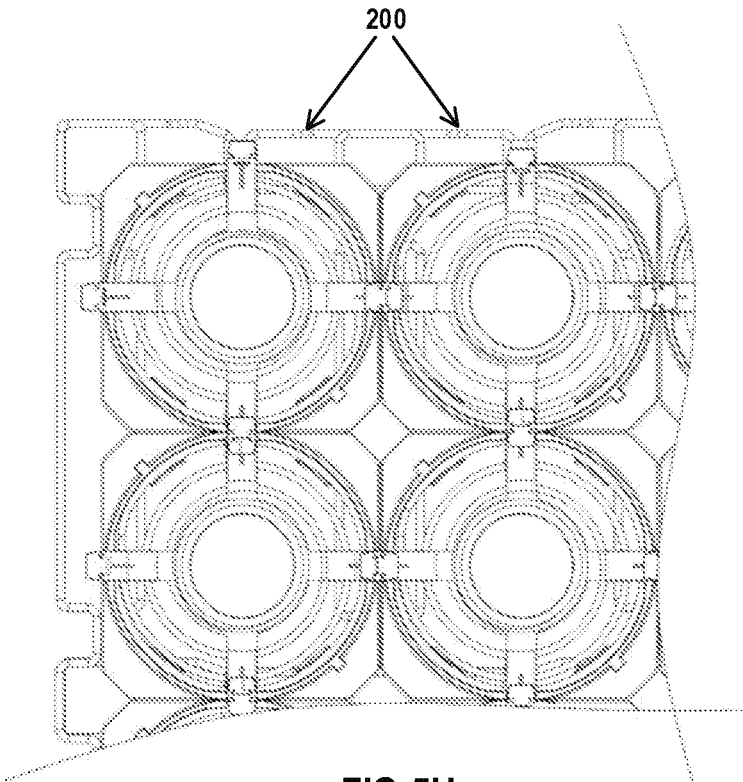

FIG. 5H

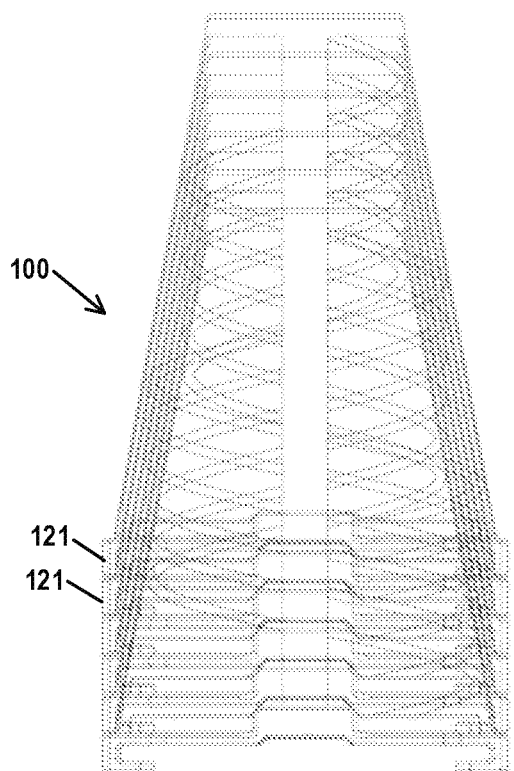

FIG. 6

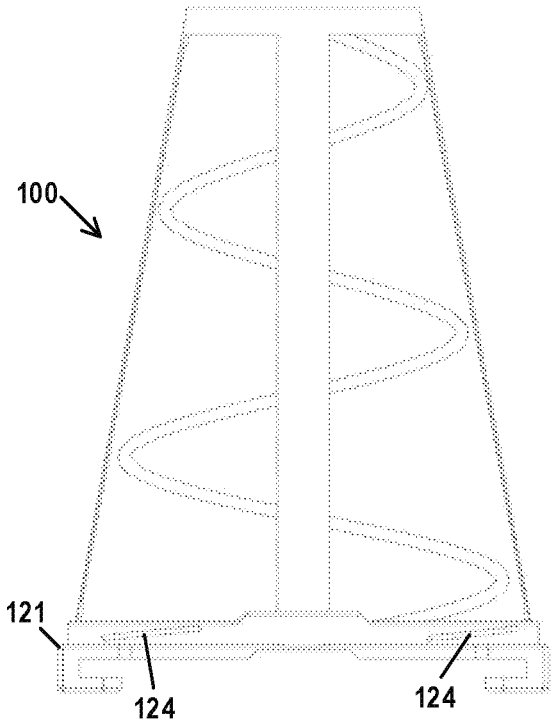

FIG.7A

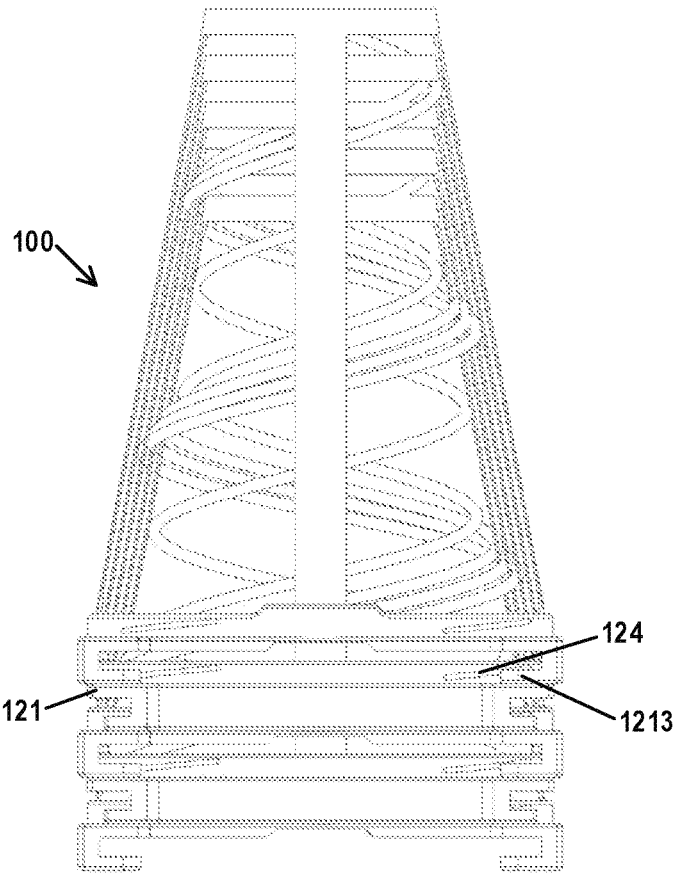

FIG.7B

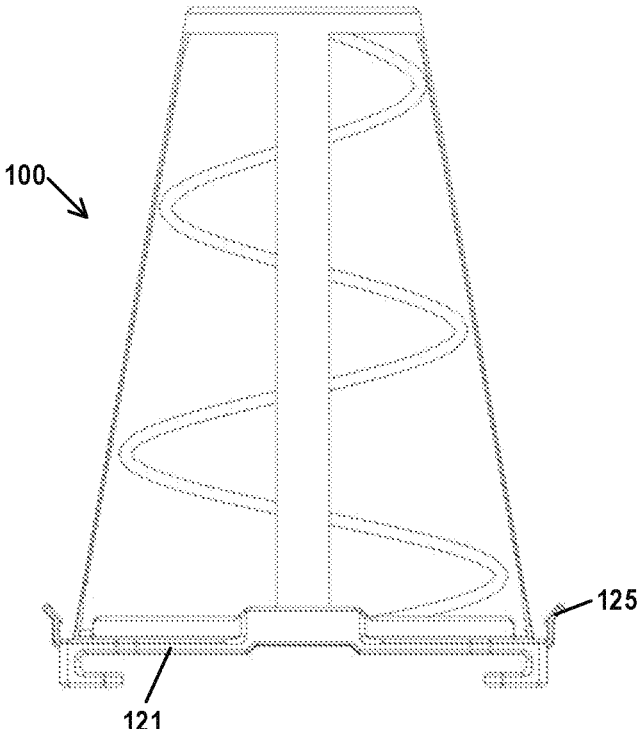

FIG.7C

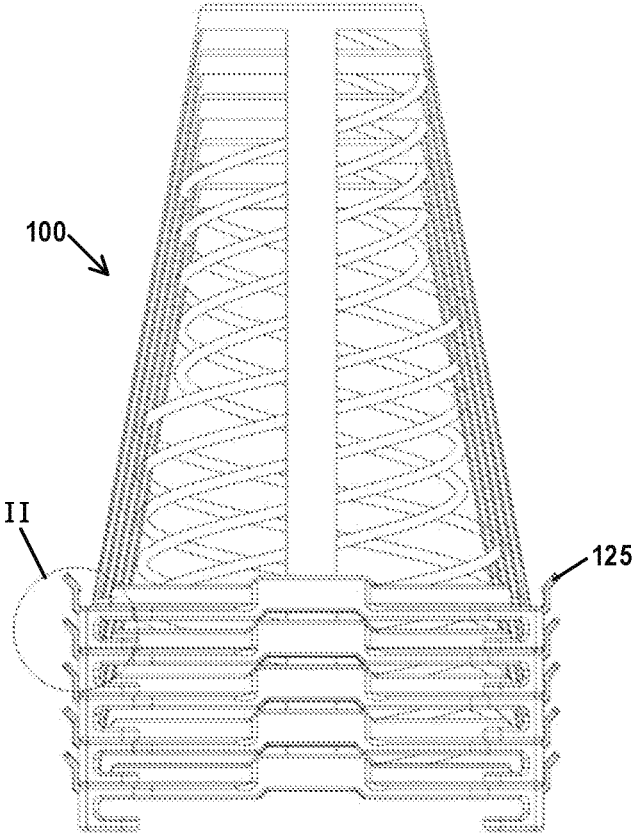

FIG.7D

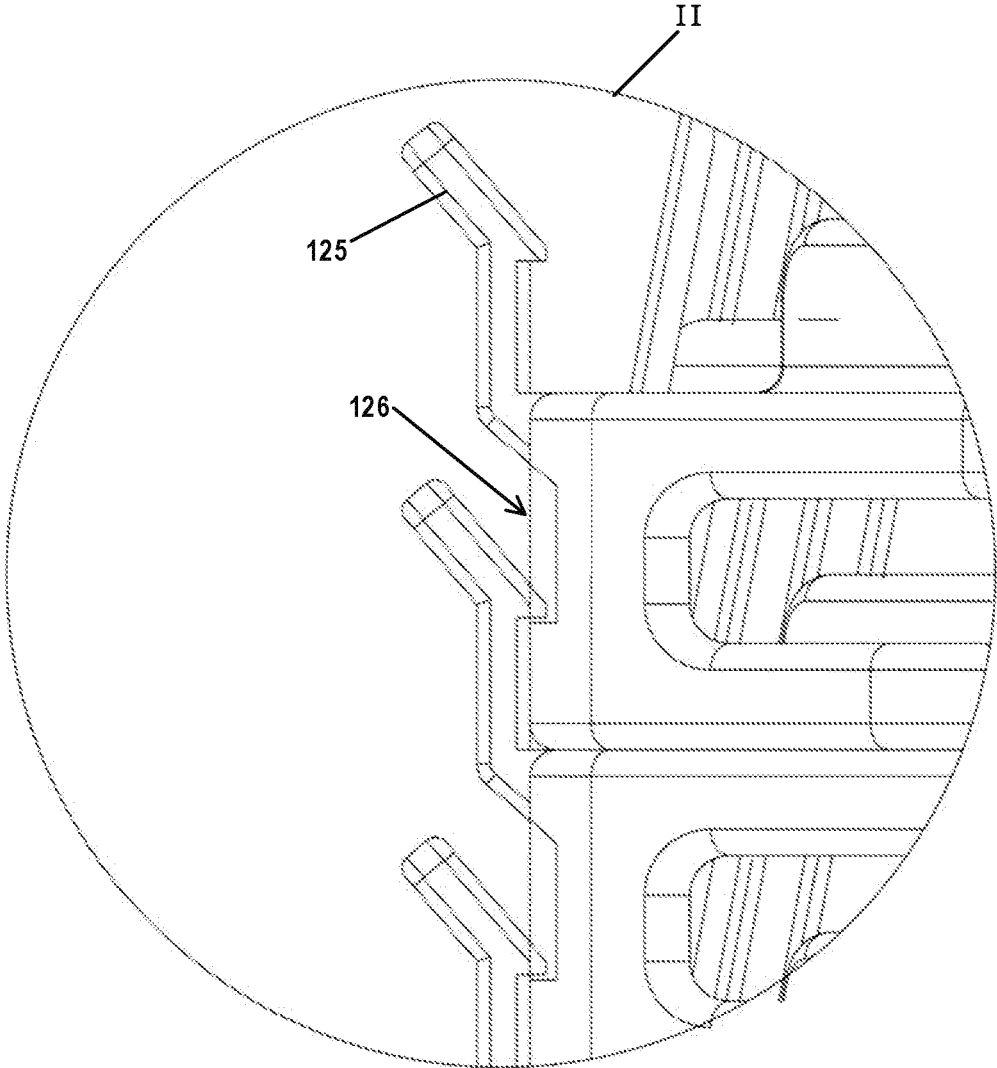

FIG.7E

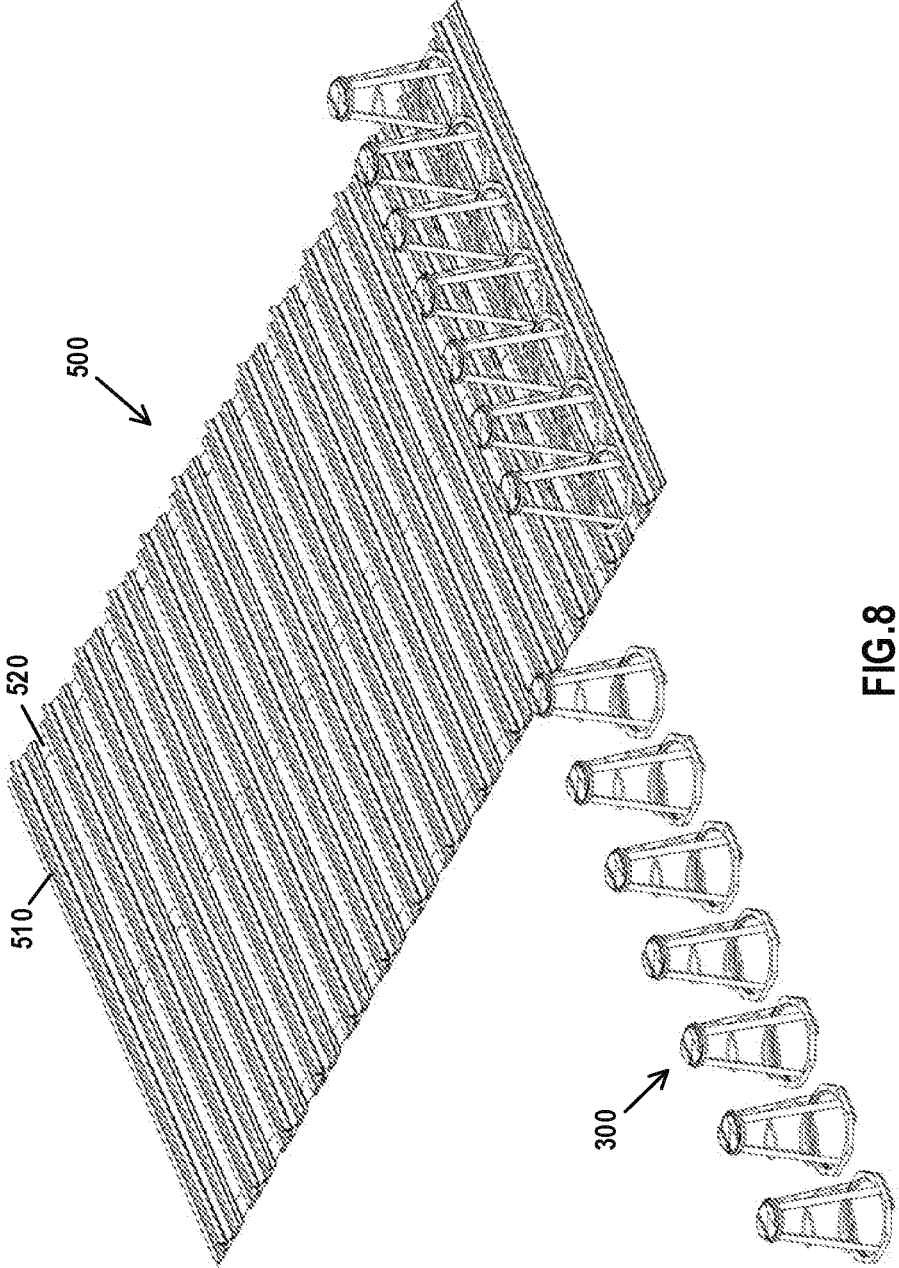

FIG.8

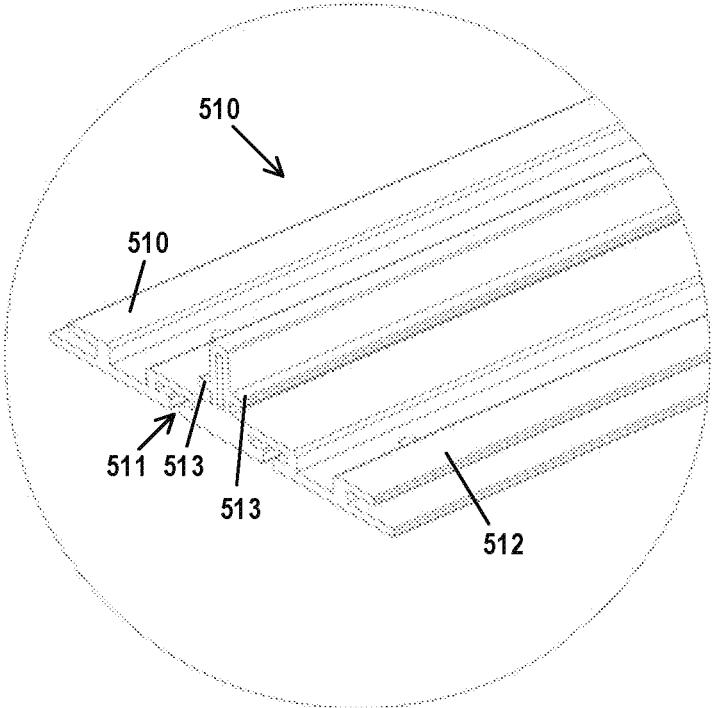

FIG.9A

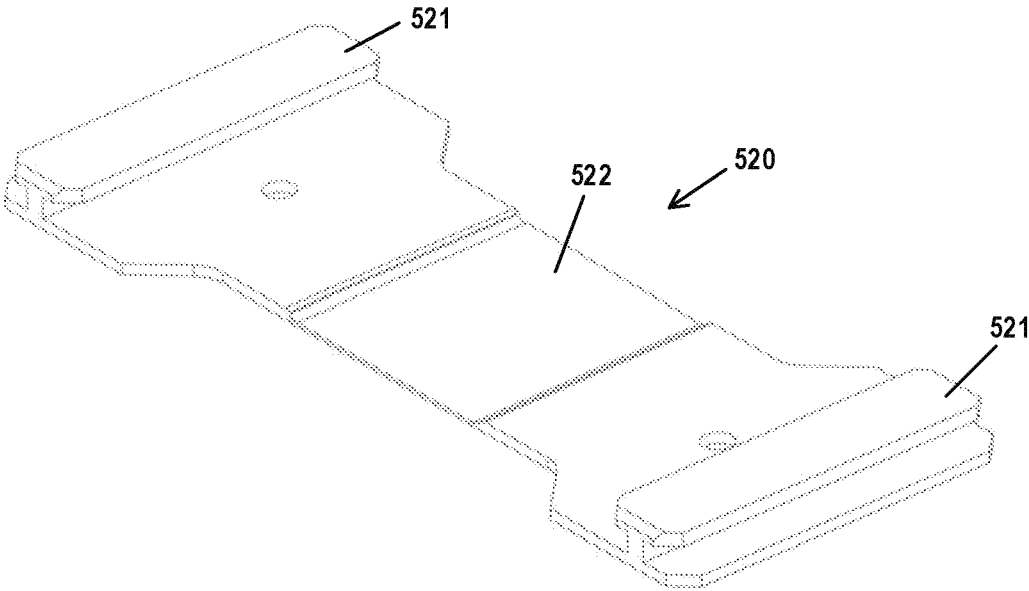

FIG.9B

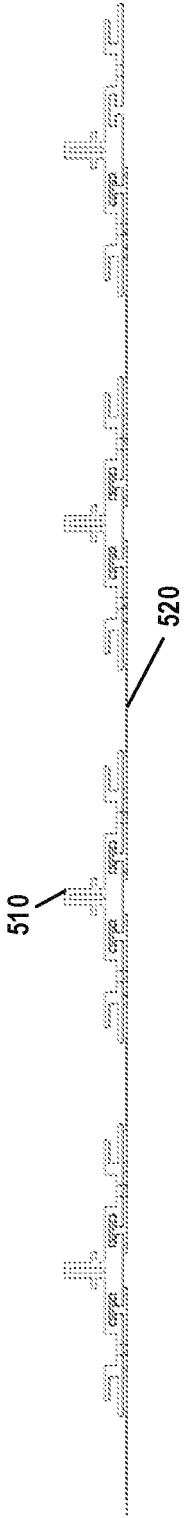

FIG.9C

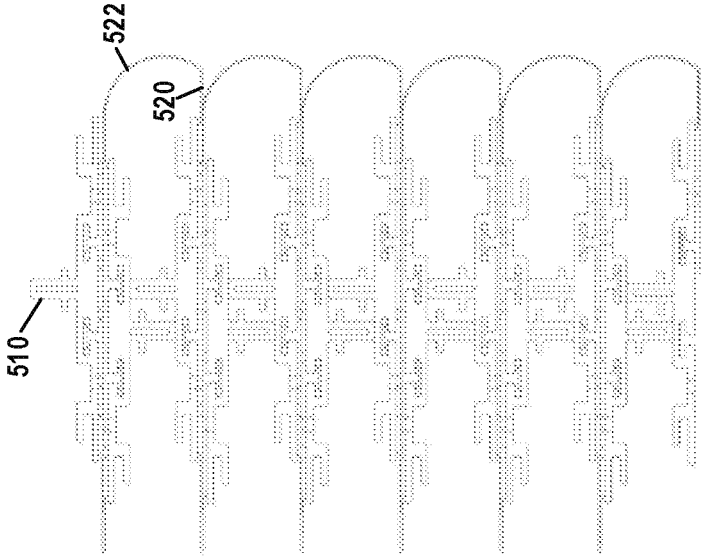

FIG.9D

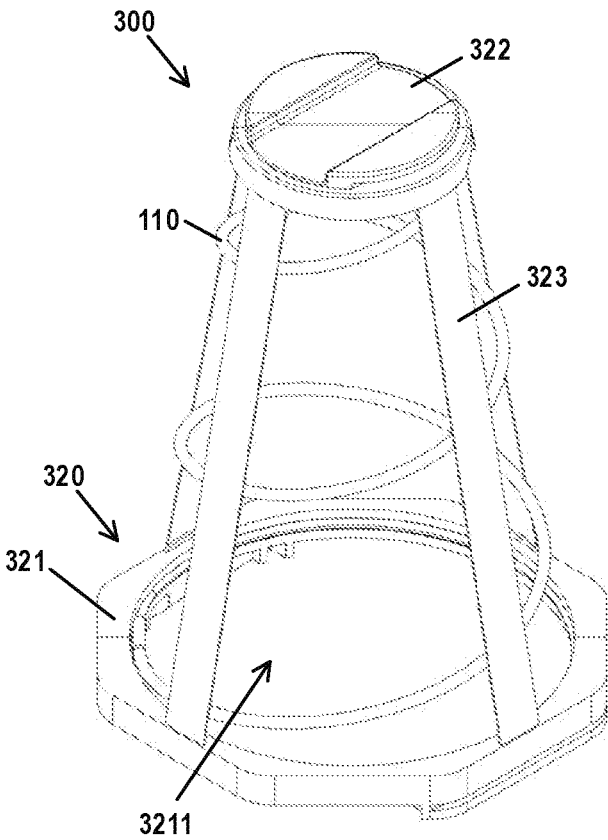

FIG. 10A

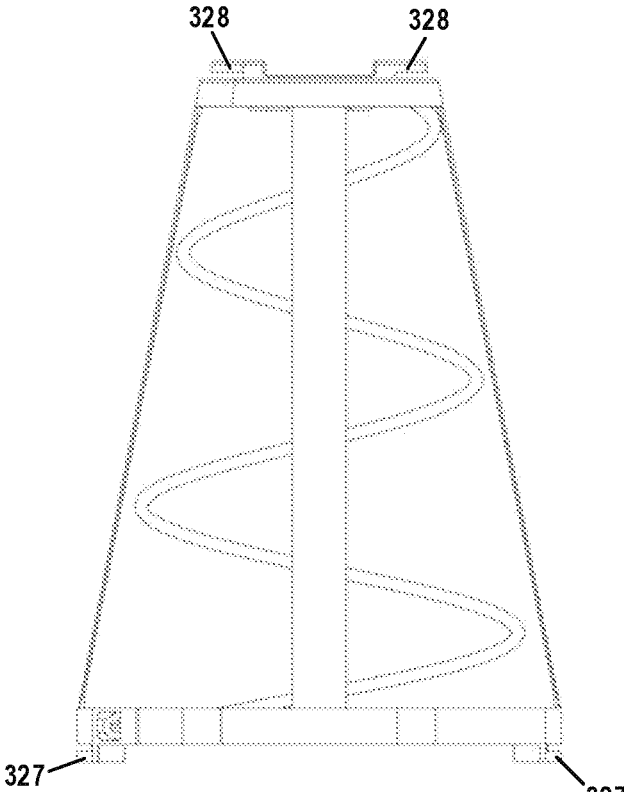

FIG. 10B

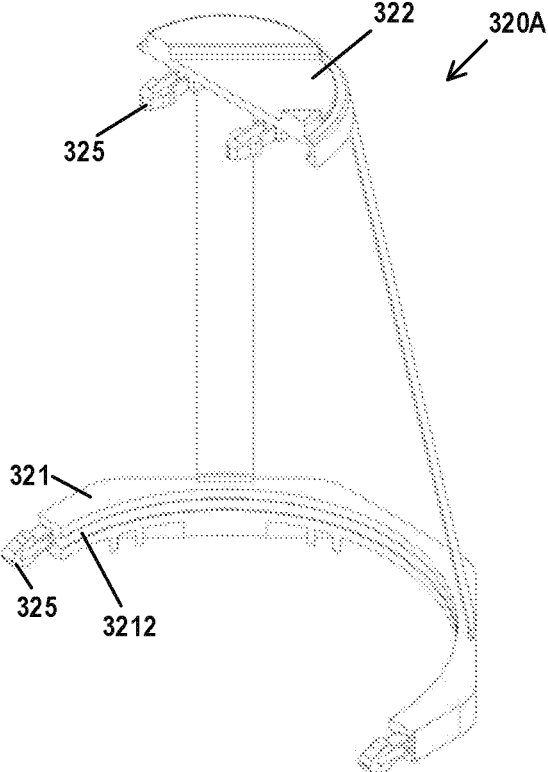

FIG. 10C

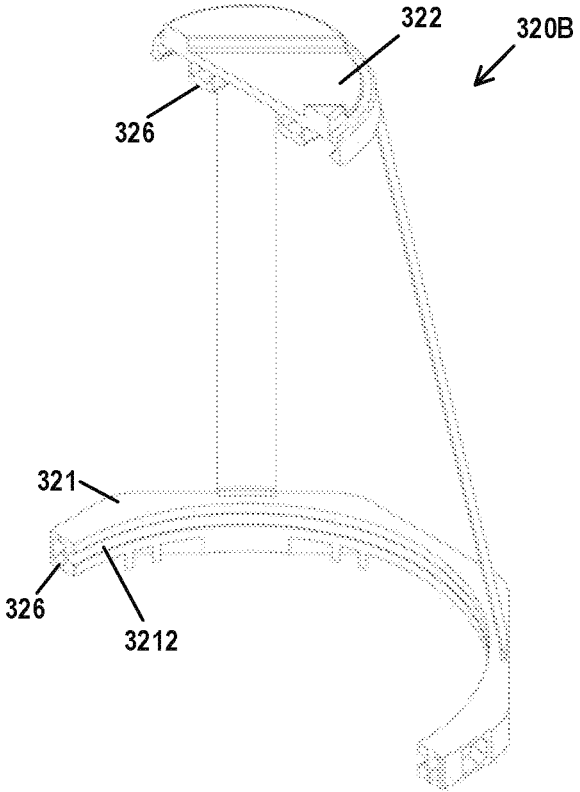

FIG. 10D

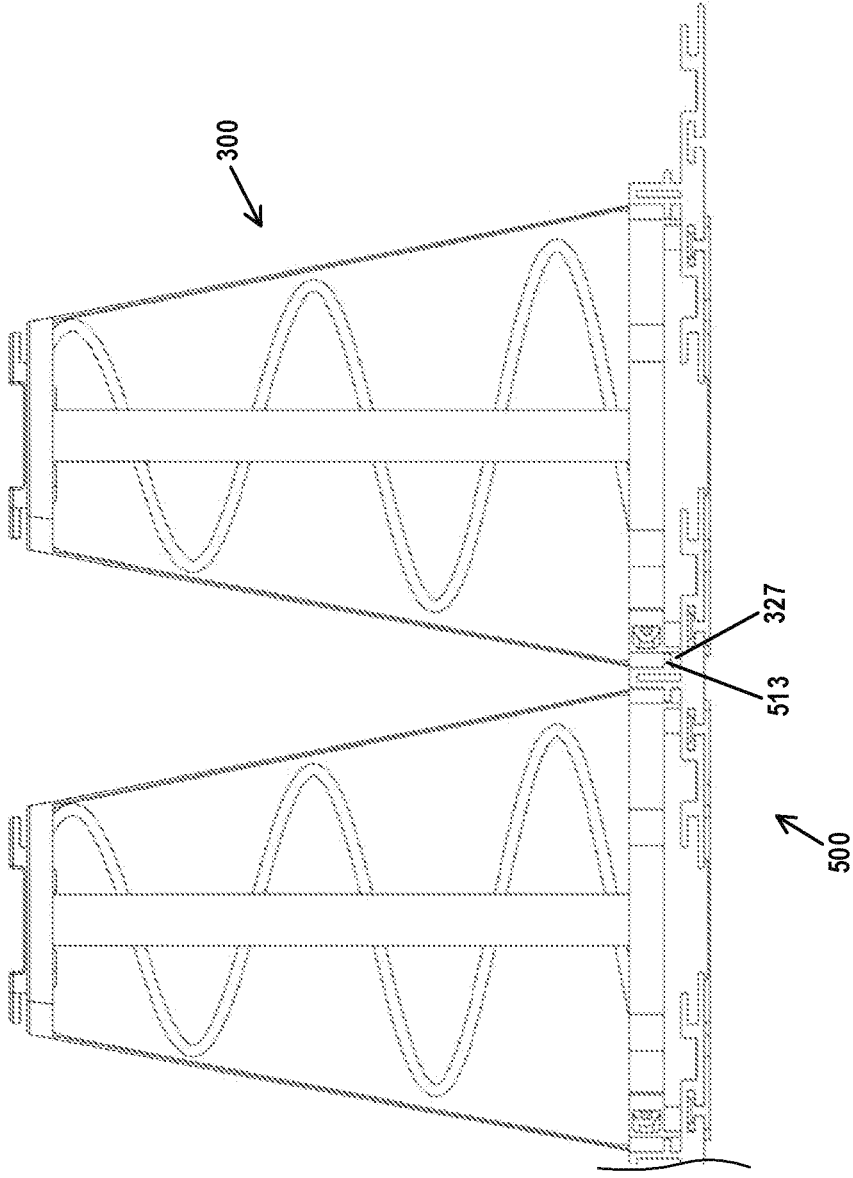

FIG.11A

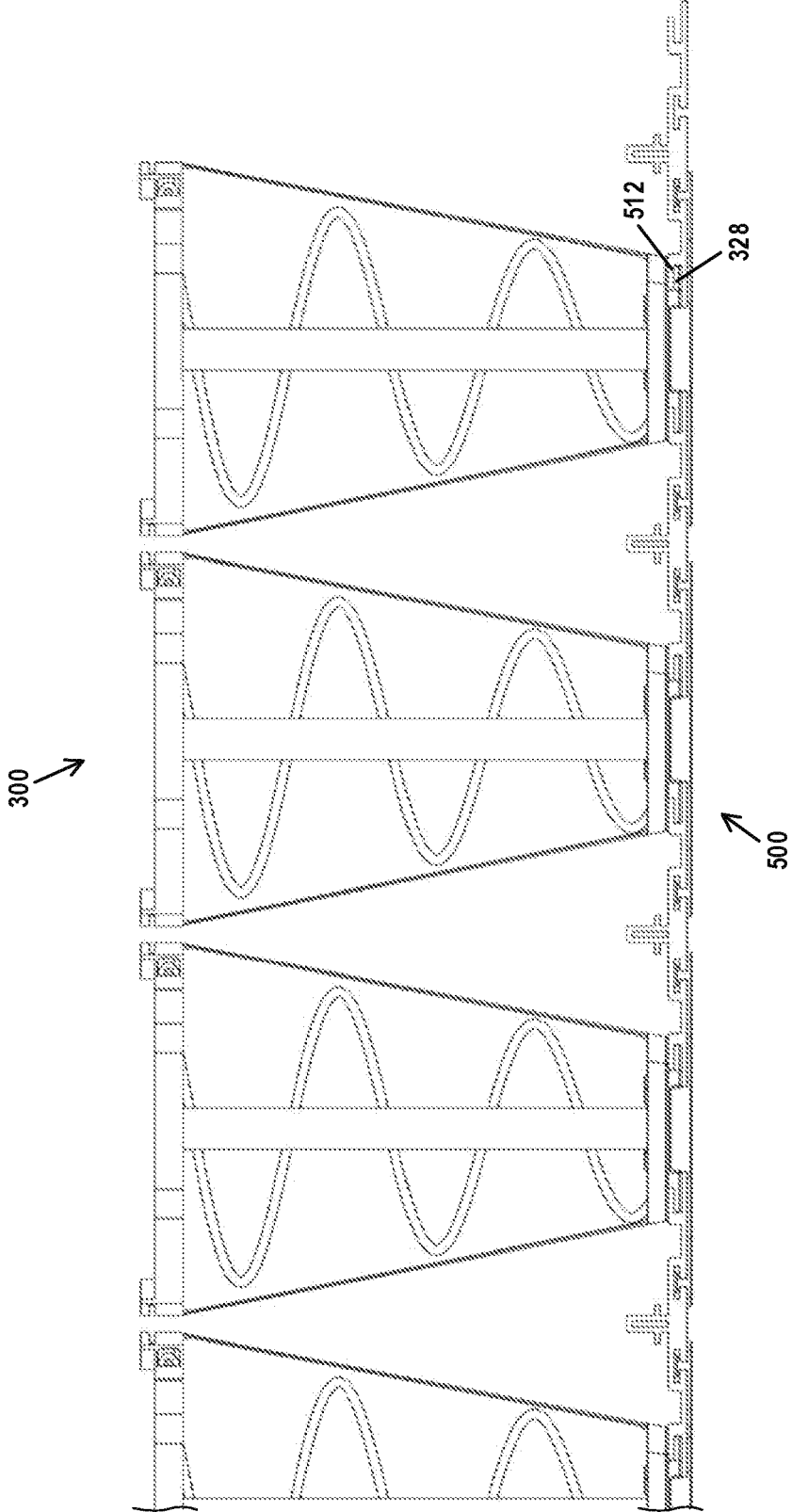

FIG.11B

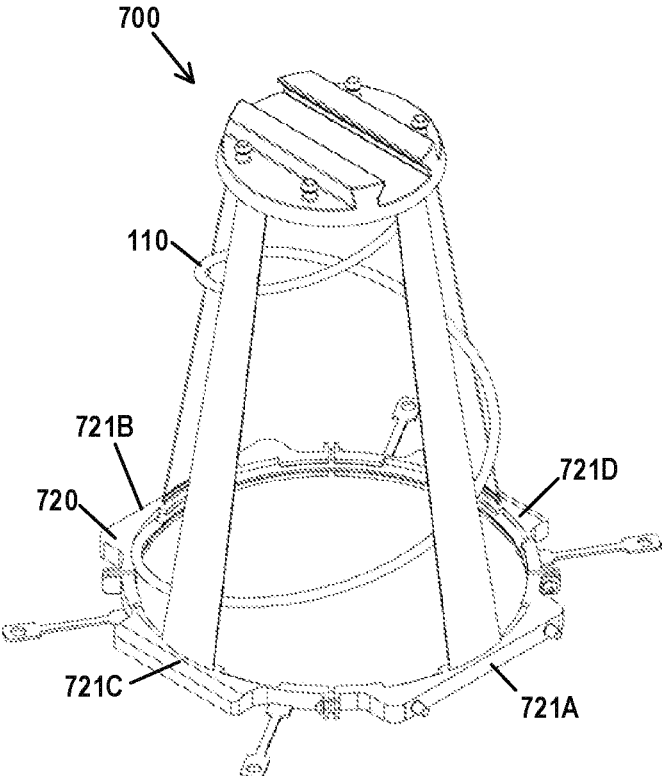

FIG. 12A

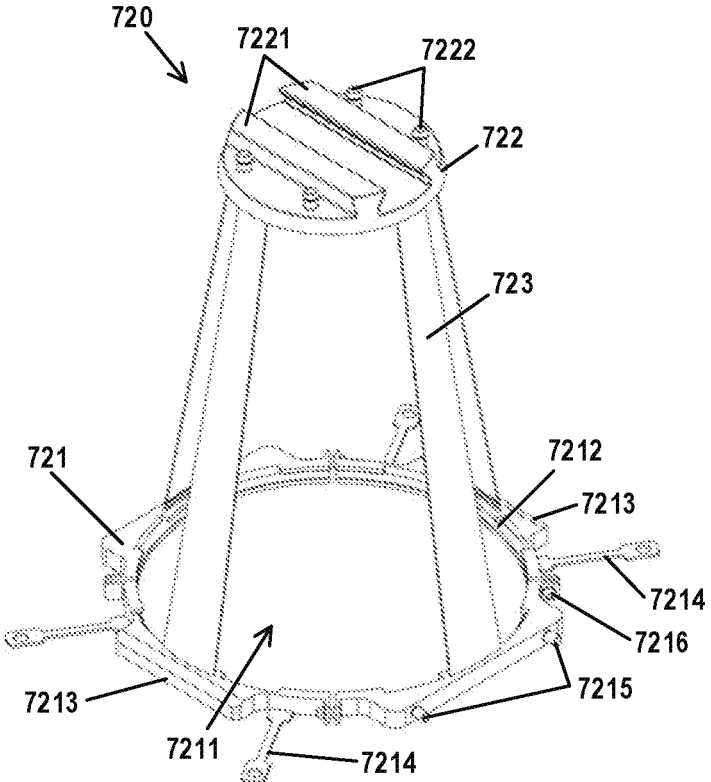

FIG. 12B

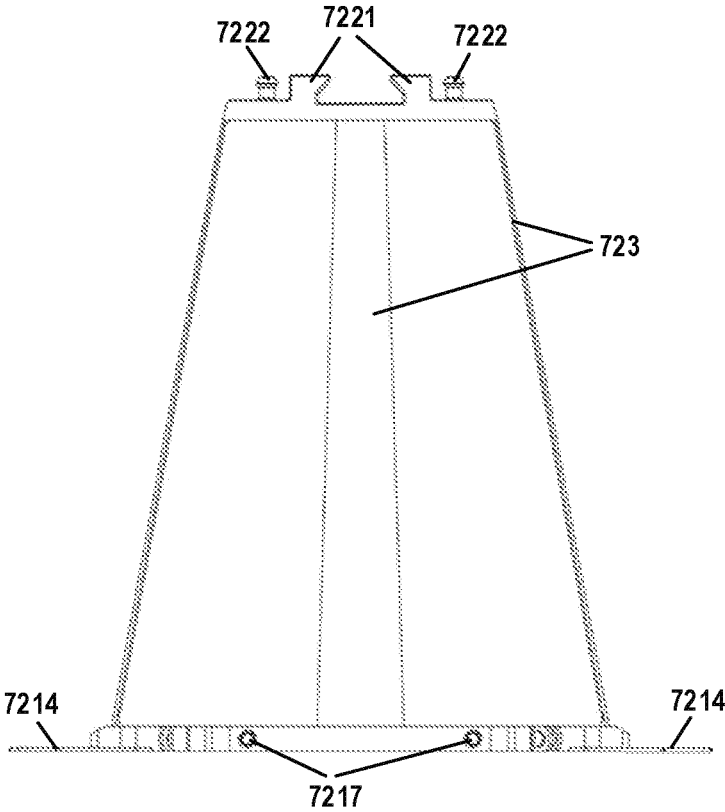

FIG. 12C

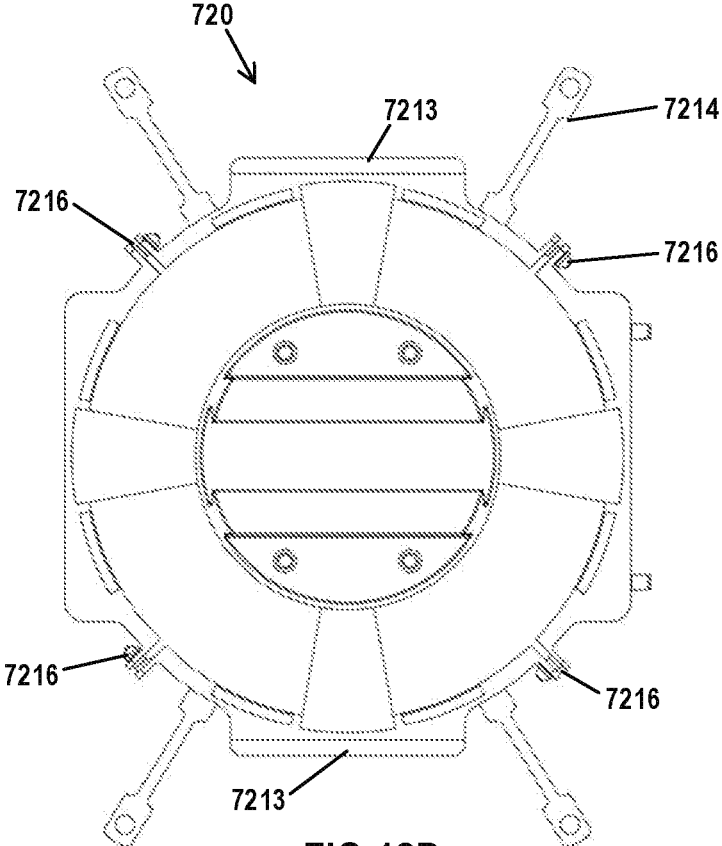

FIG. 12D

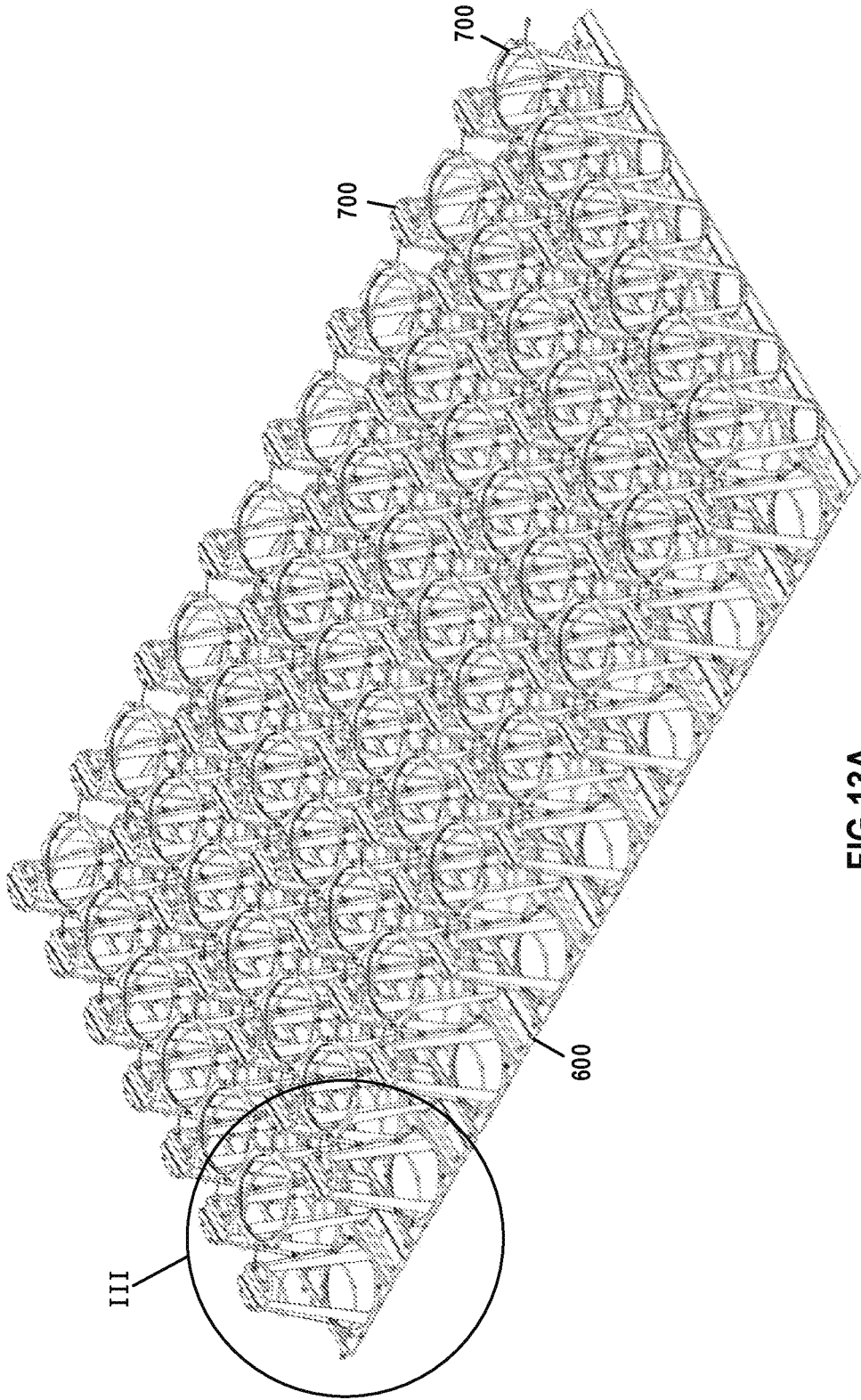

FIG.13A

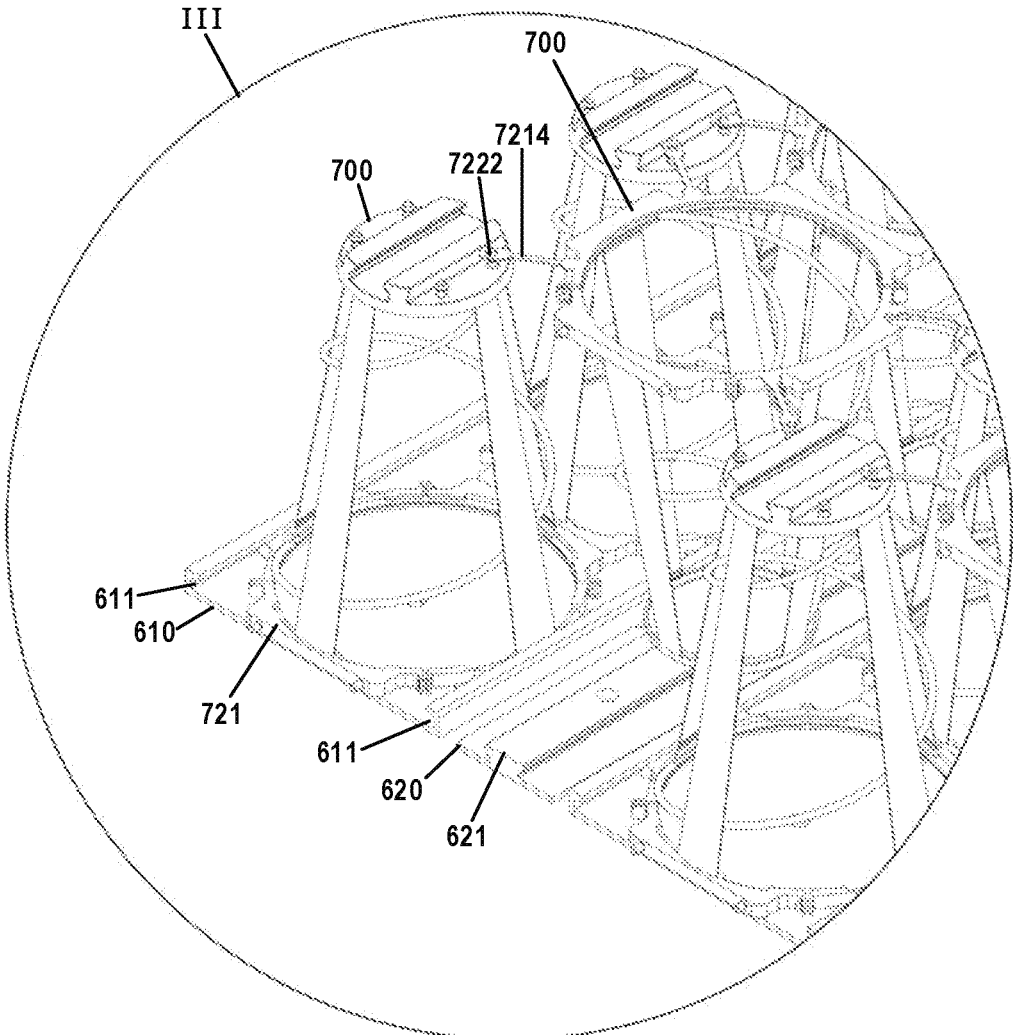
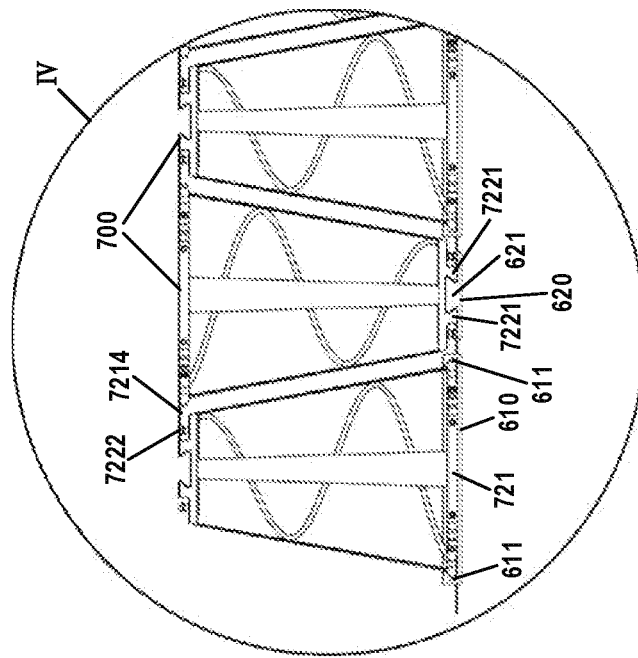
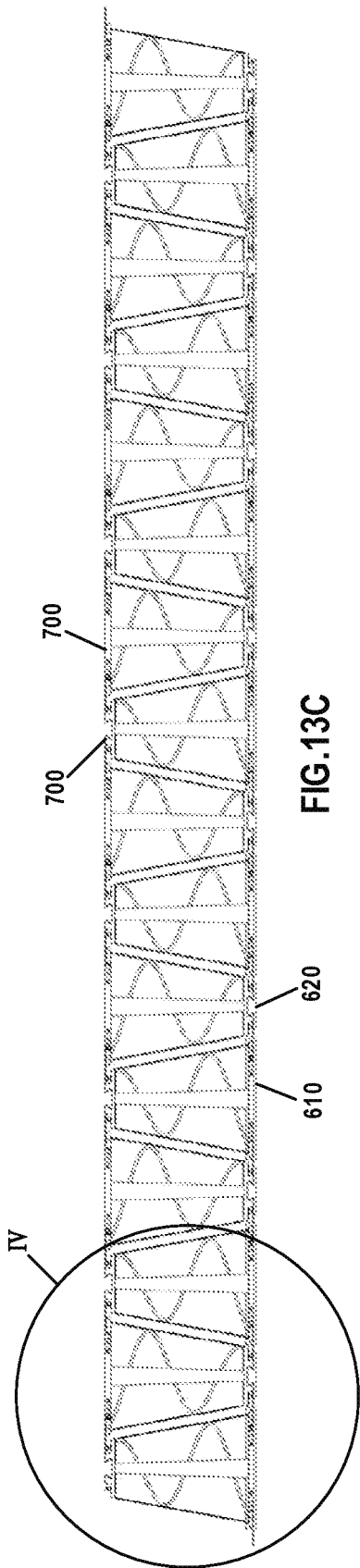

FIG.13B



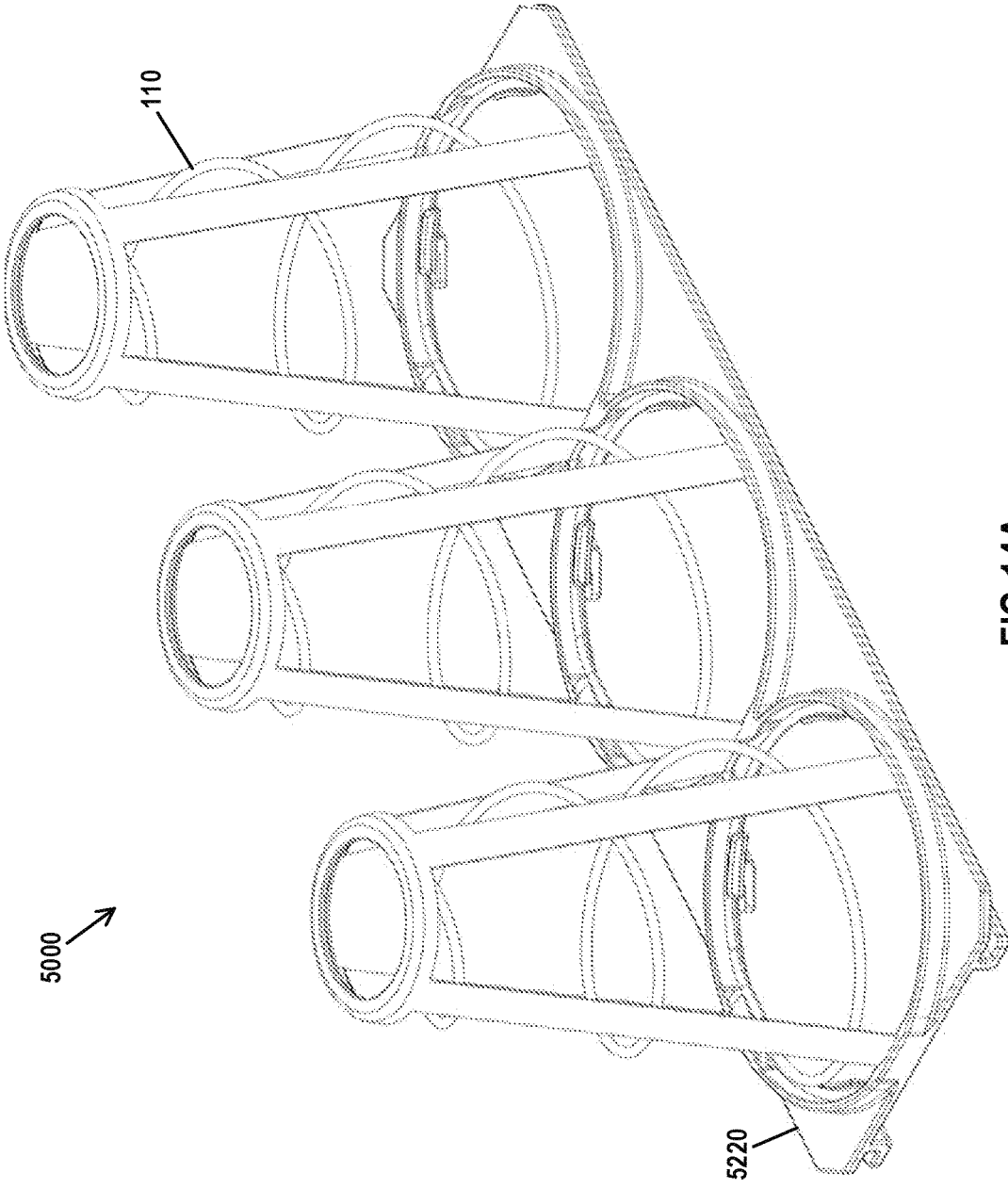

FIG.14A

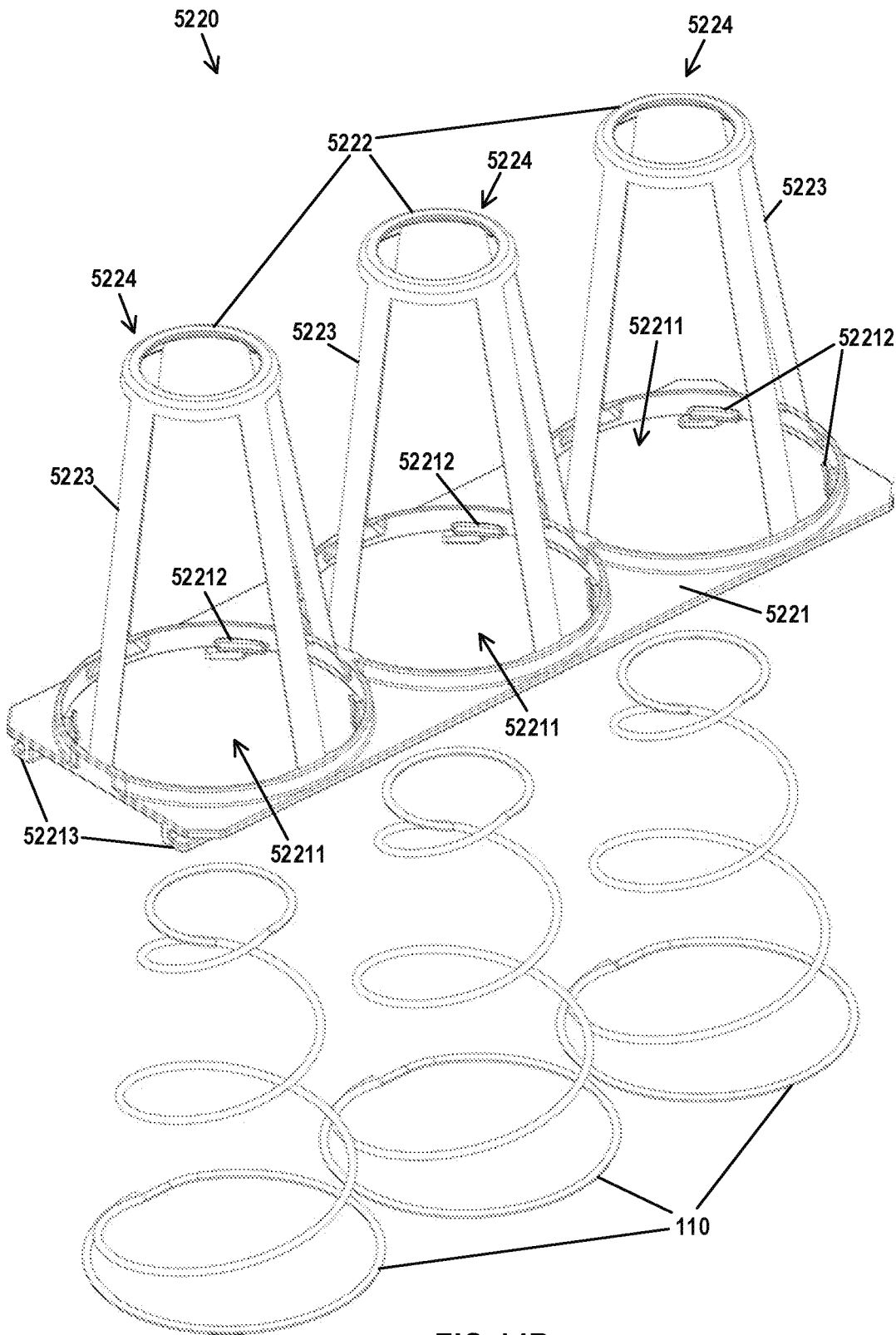

FIG.14B

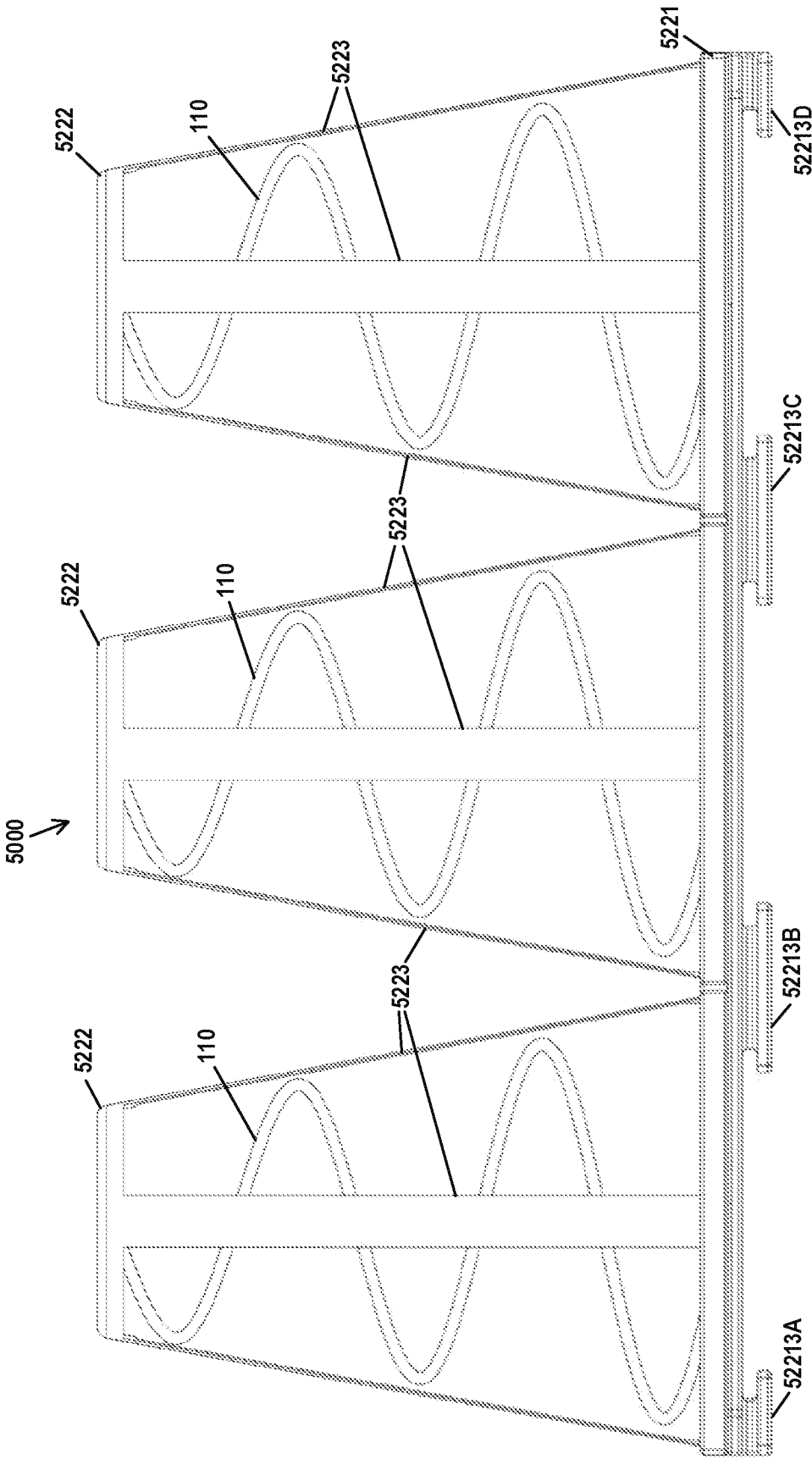

FIG.14C

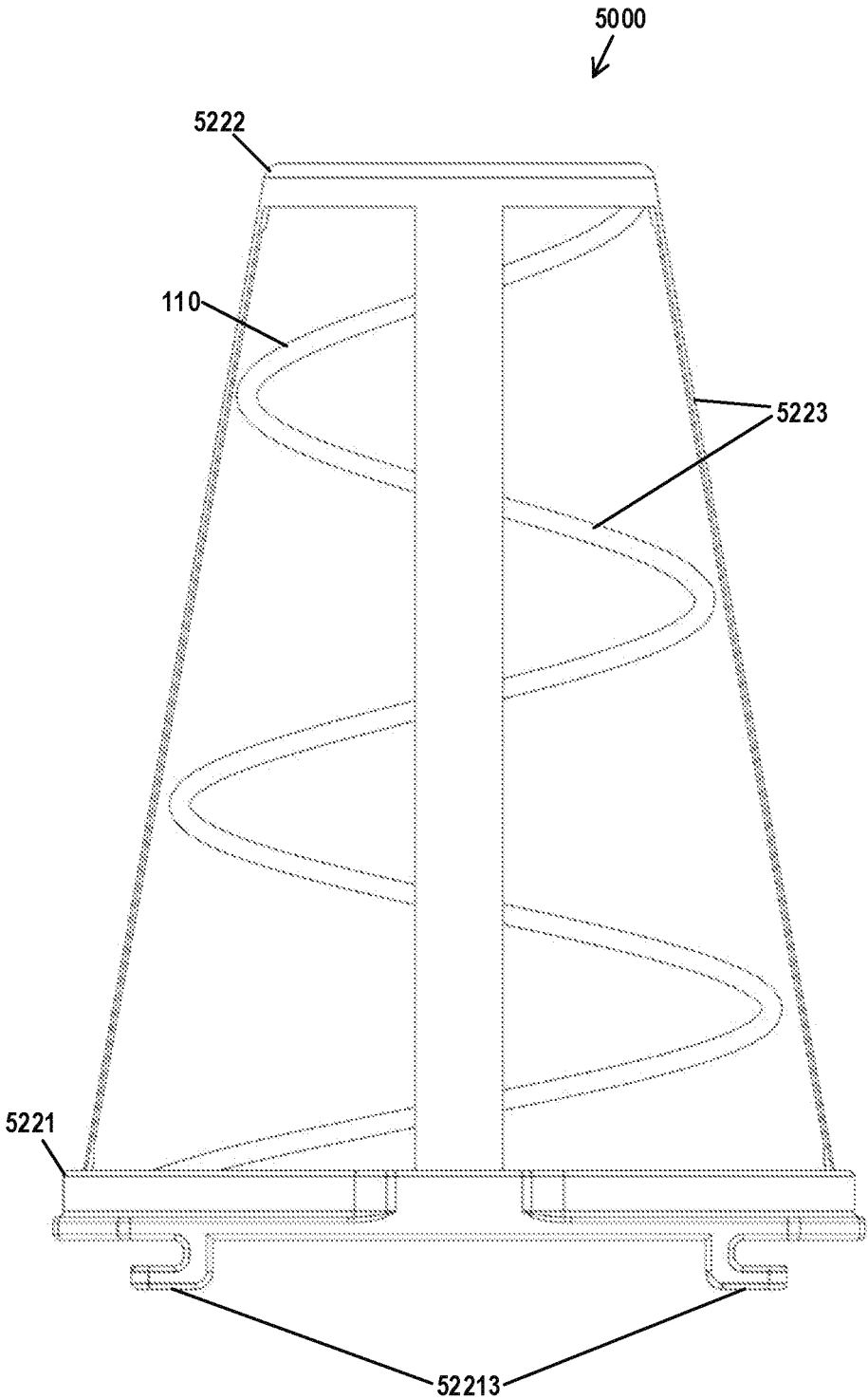

FIG.14D

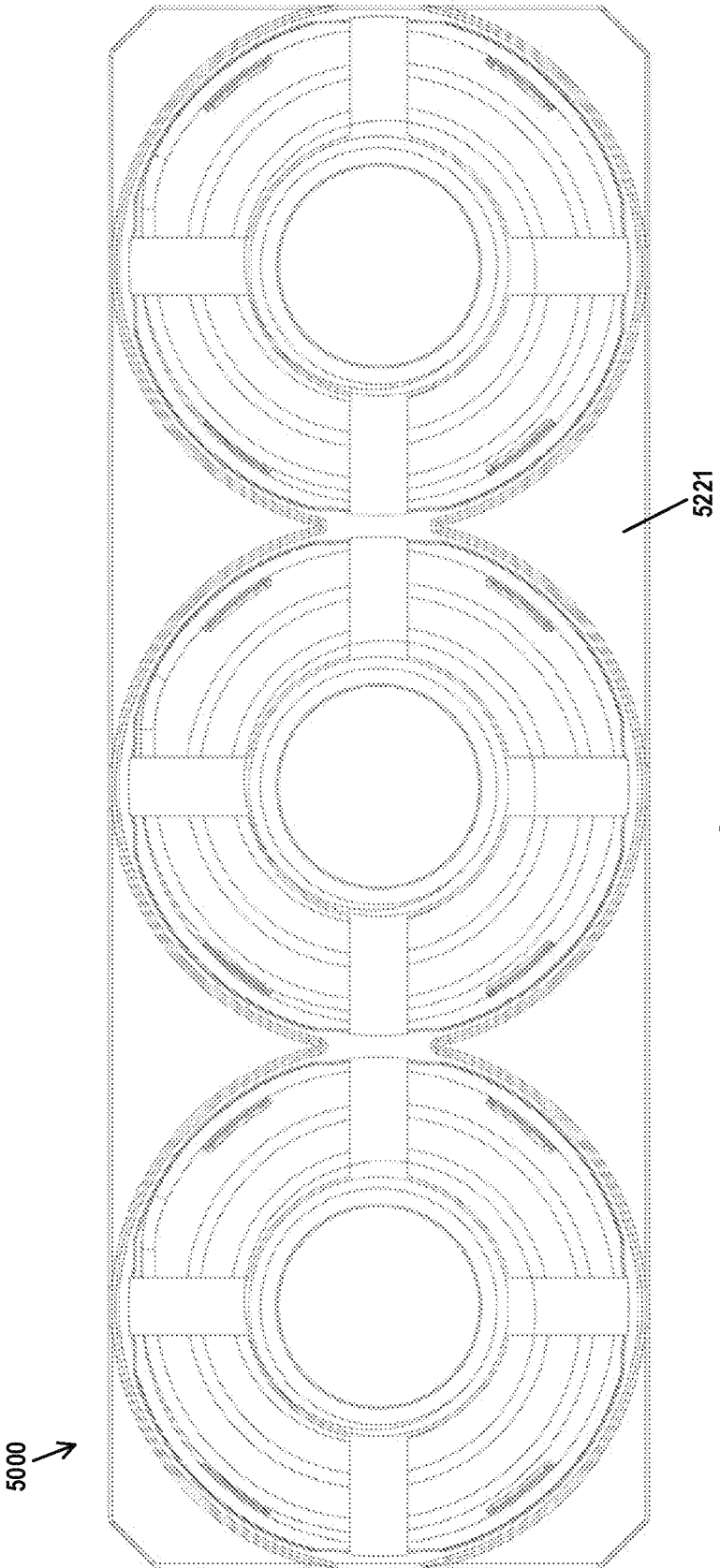

FIG.14E

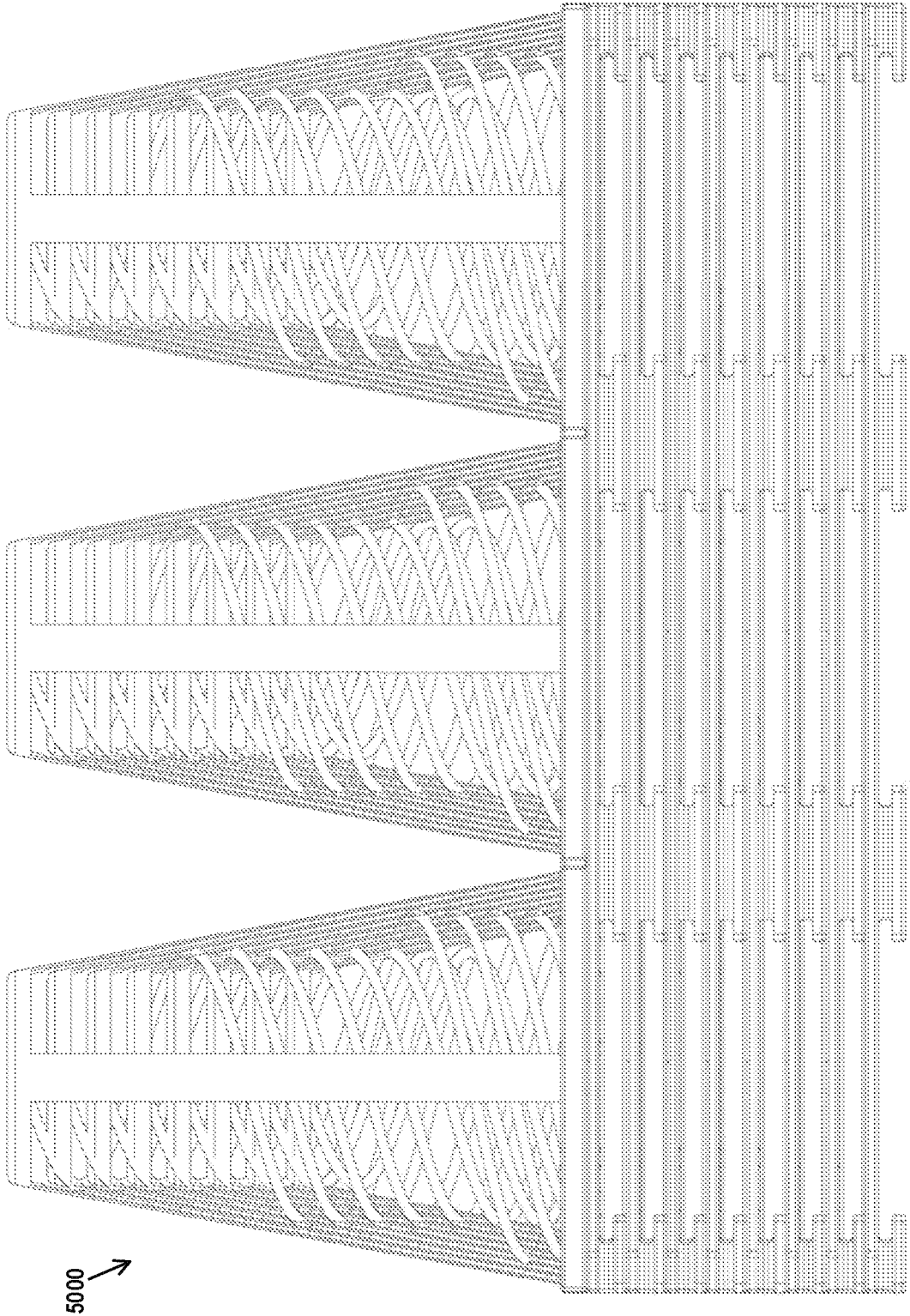

FIG.15

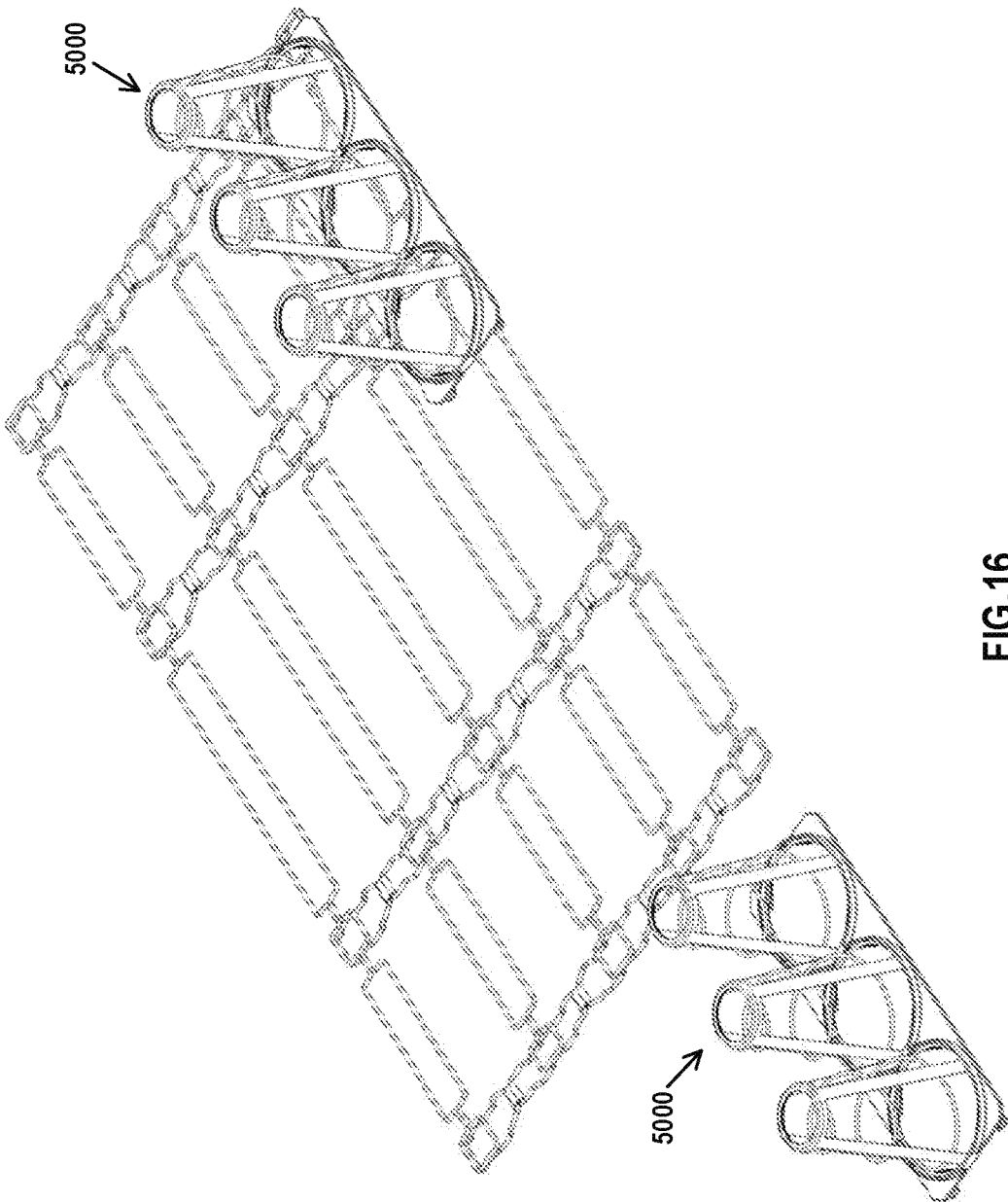

FIG.16

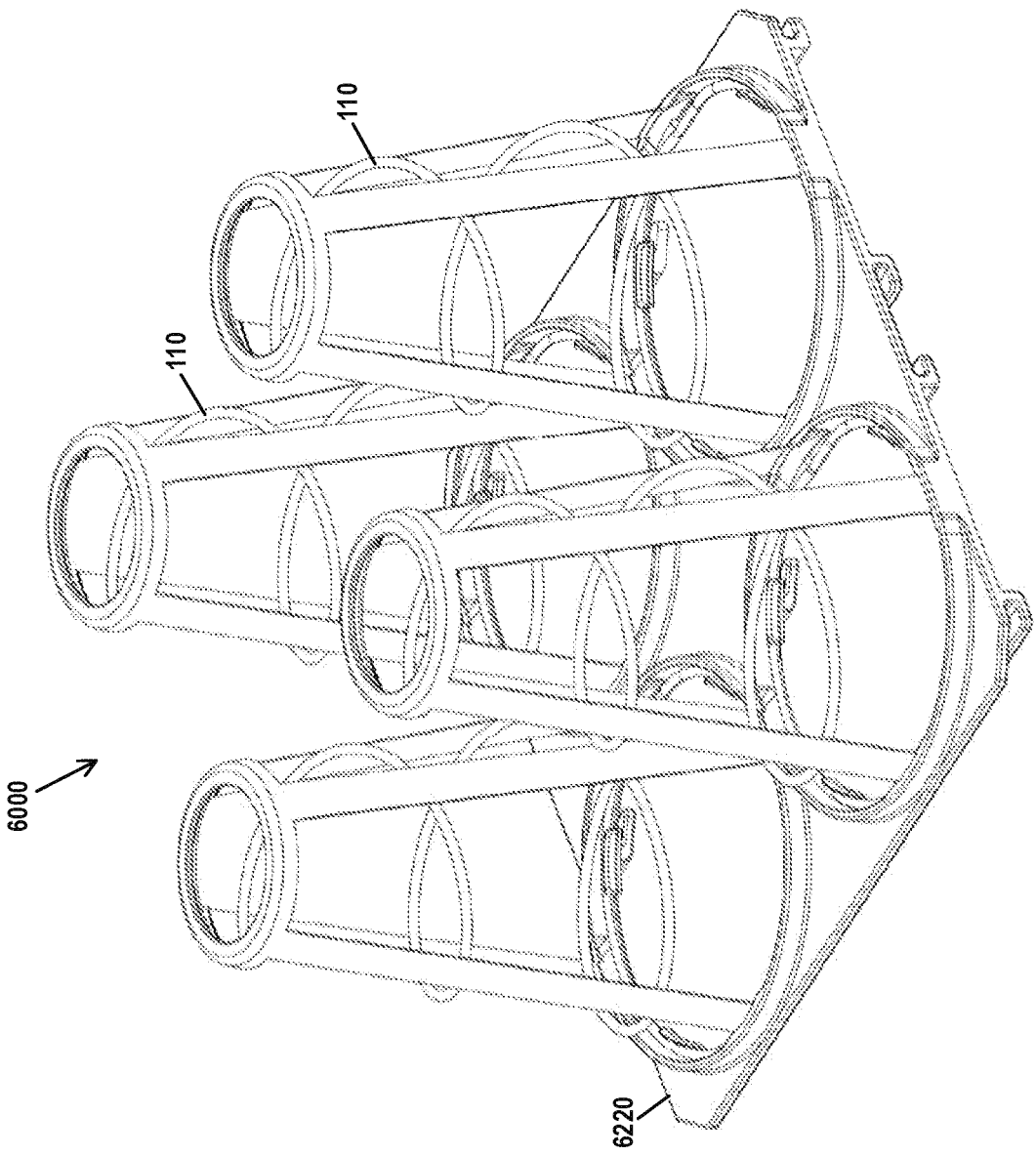

FIG.17A

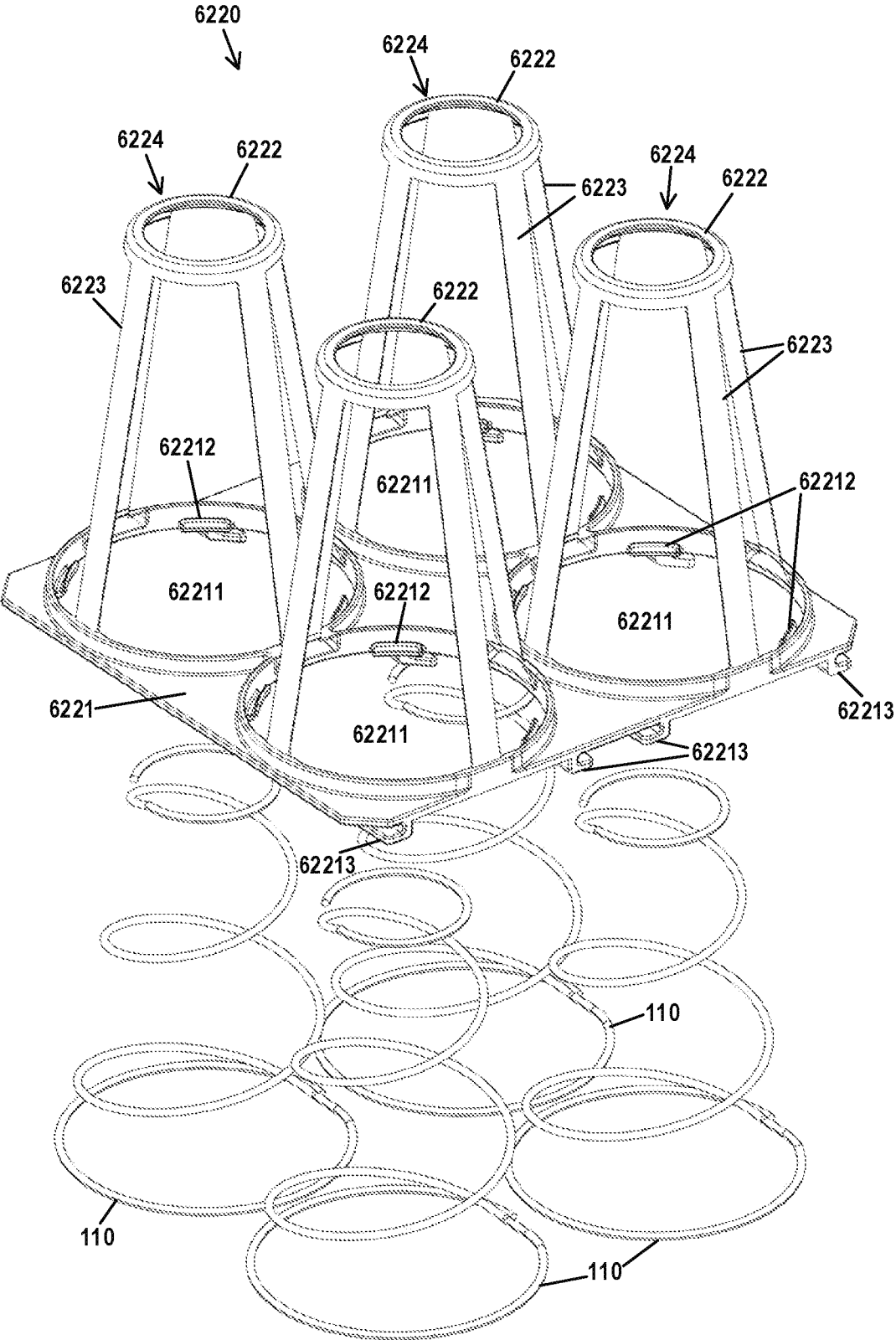

FIG.17B

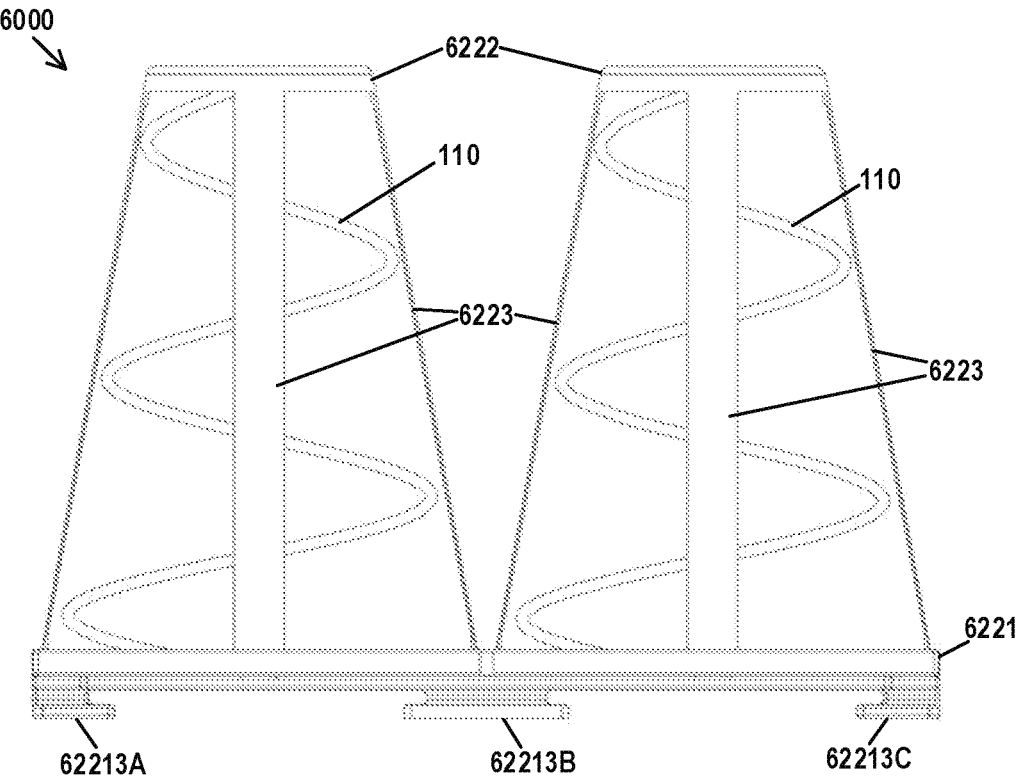

FIG.17C

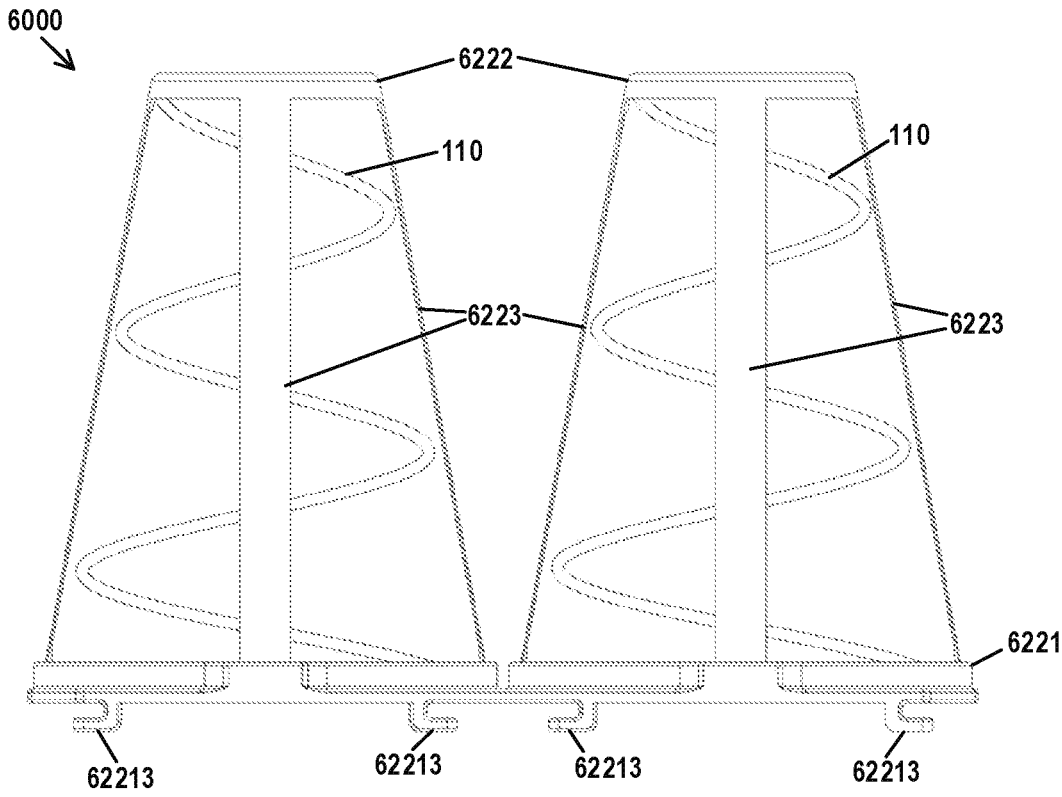

FIG.17D

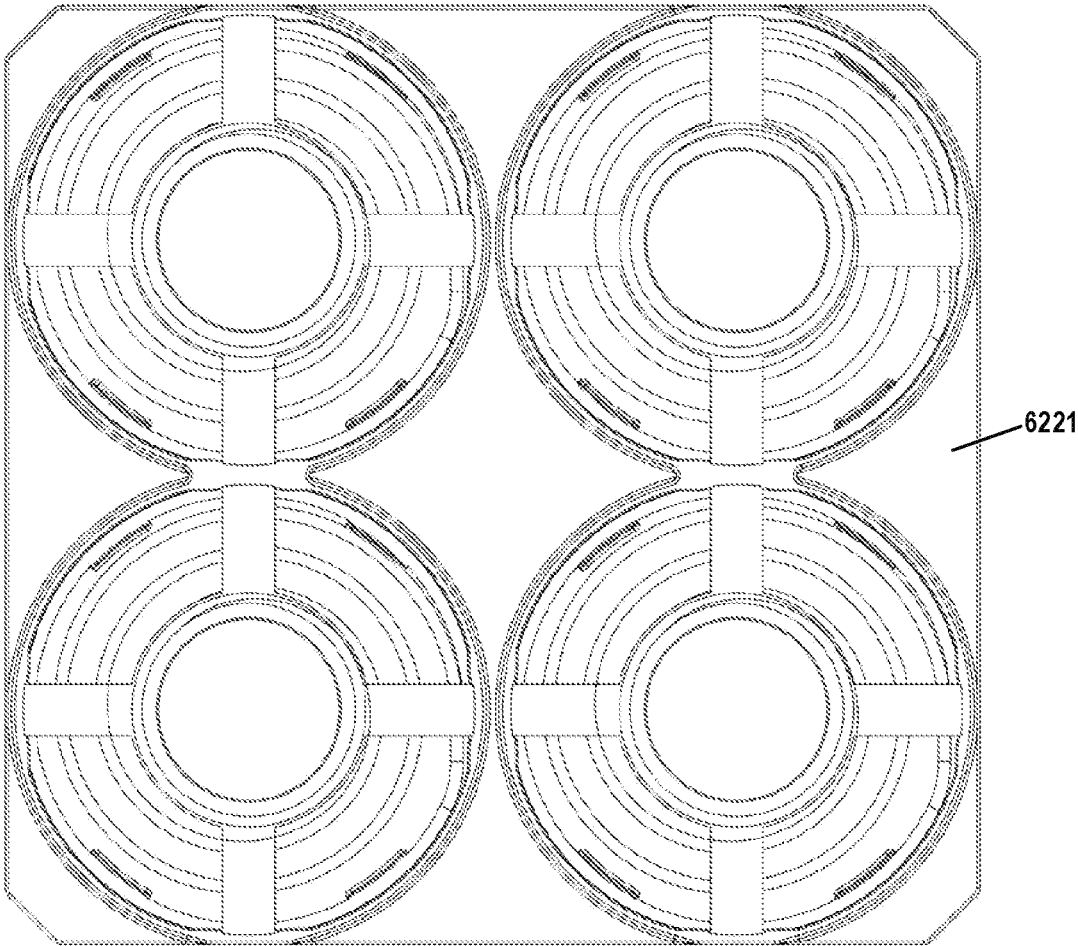

FIG.17E

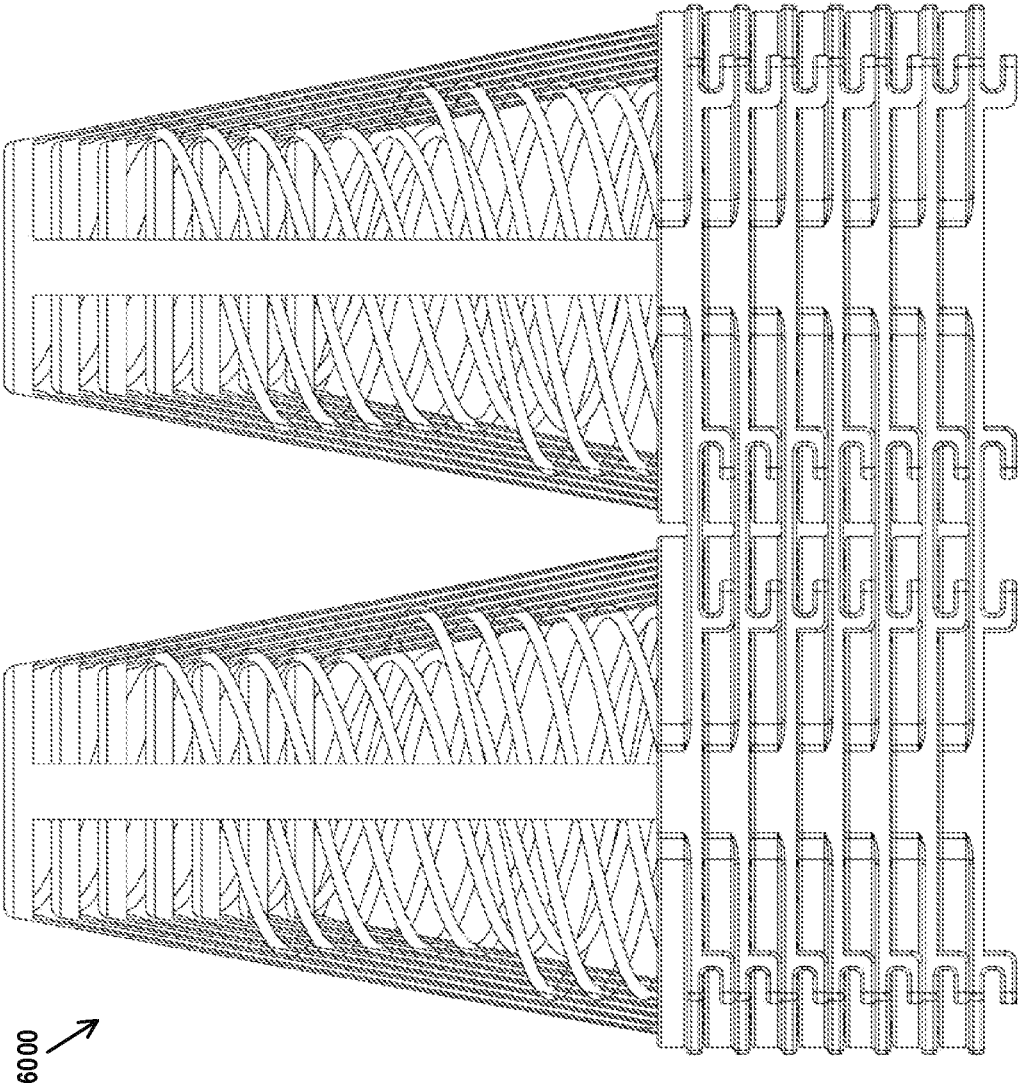

FIG.18

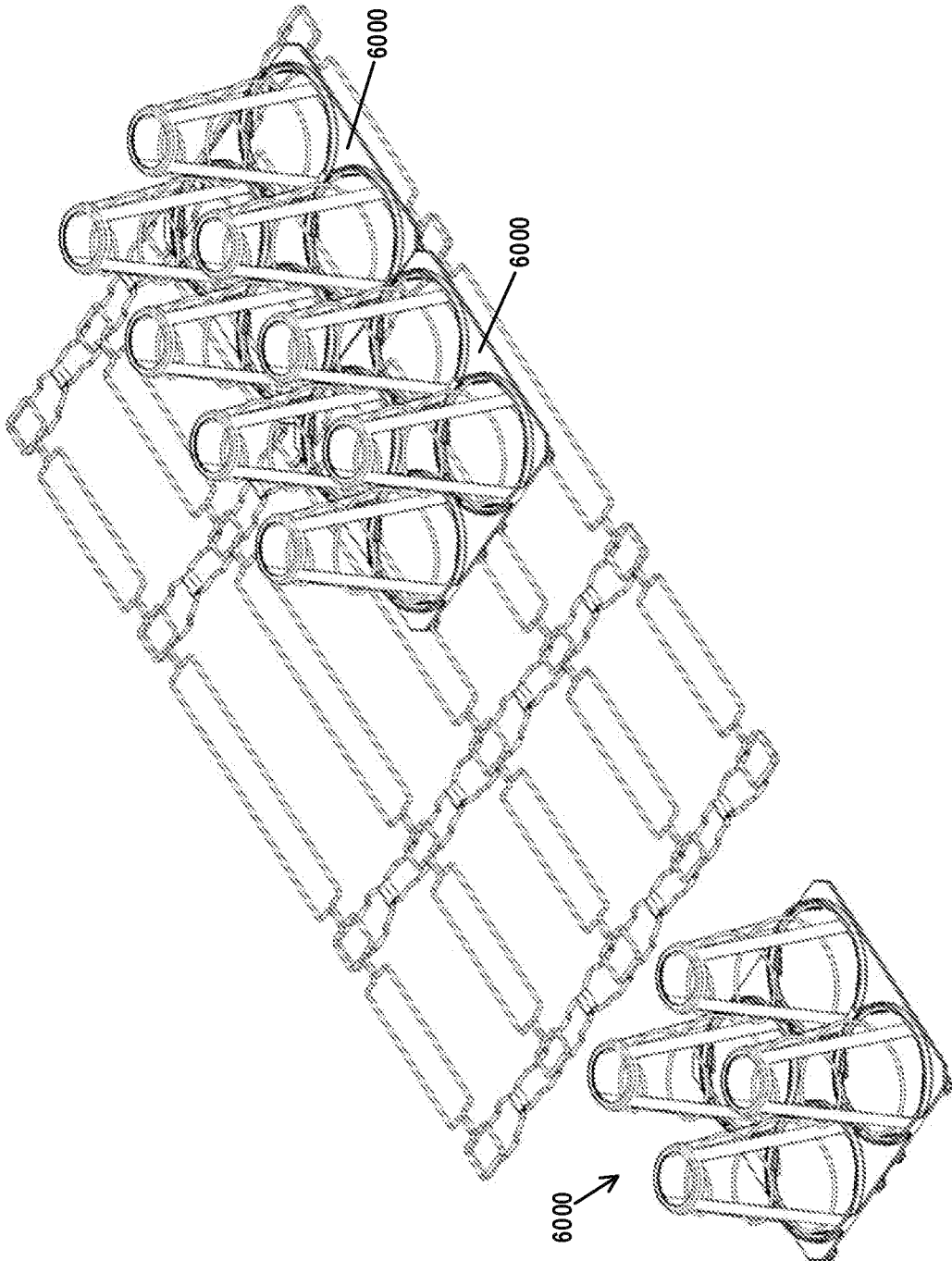

FIG.19

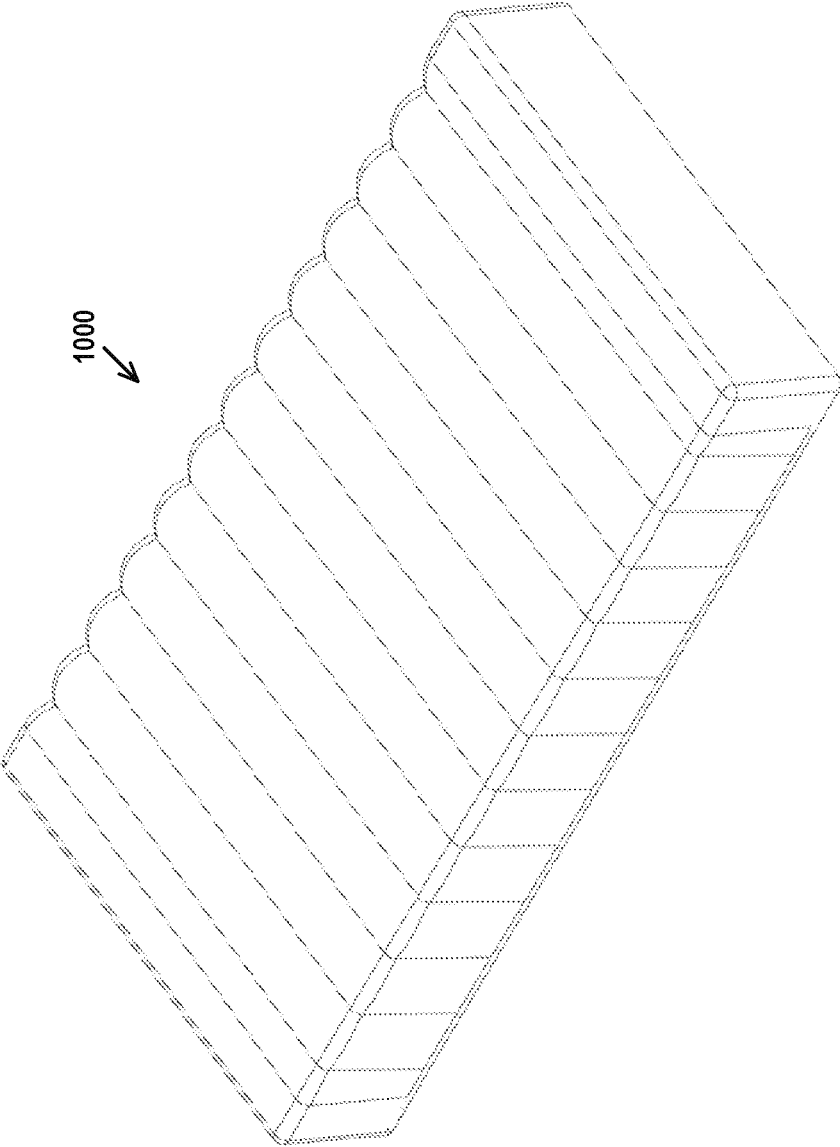

FIG.20A

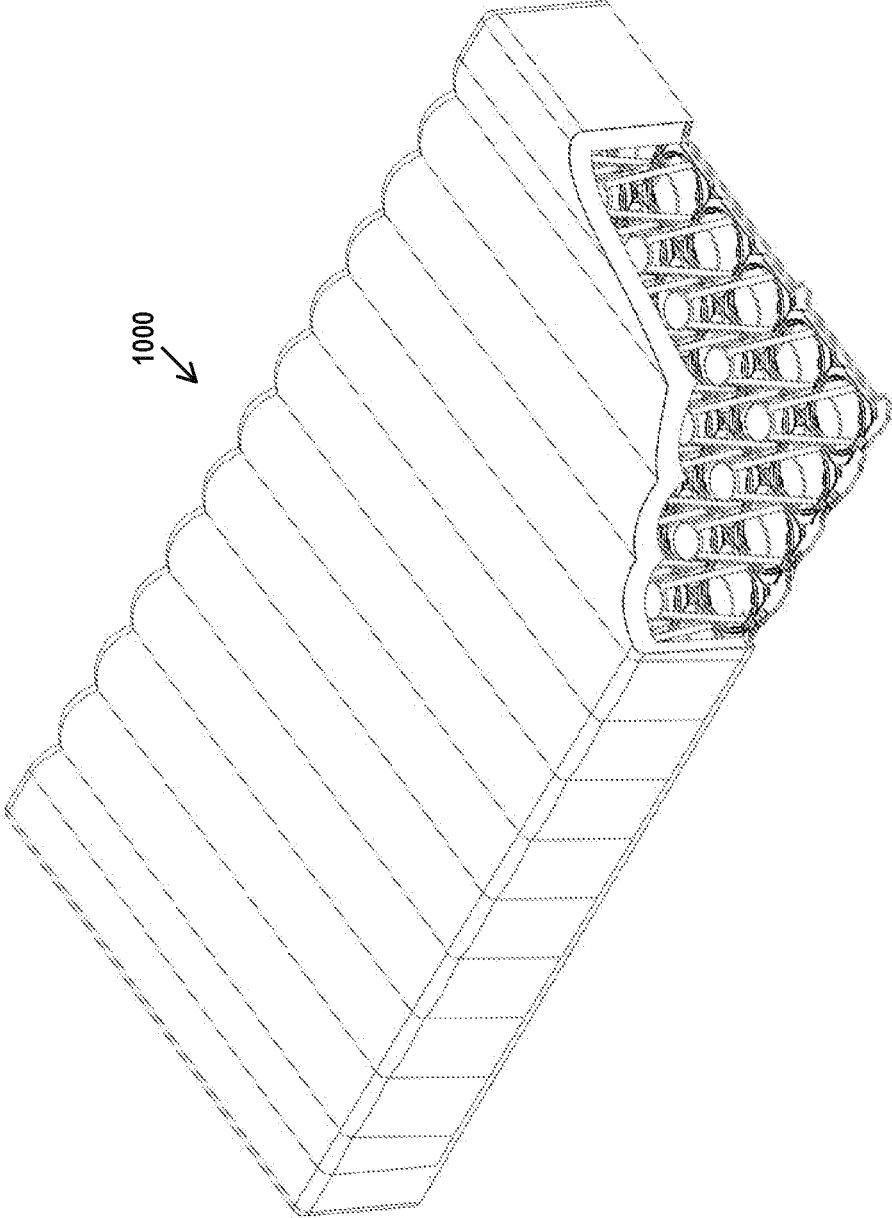

FIG.20B

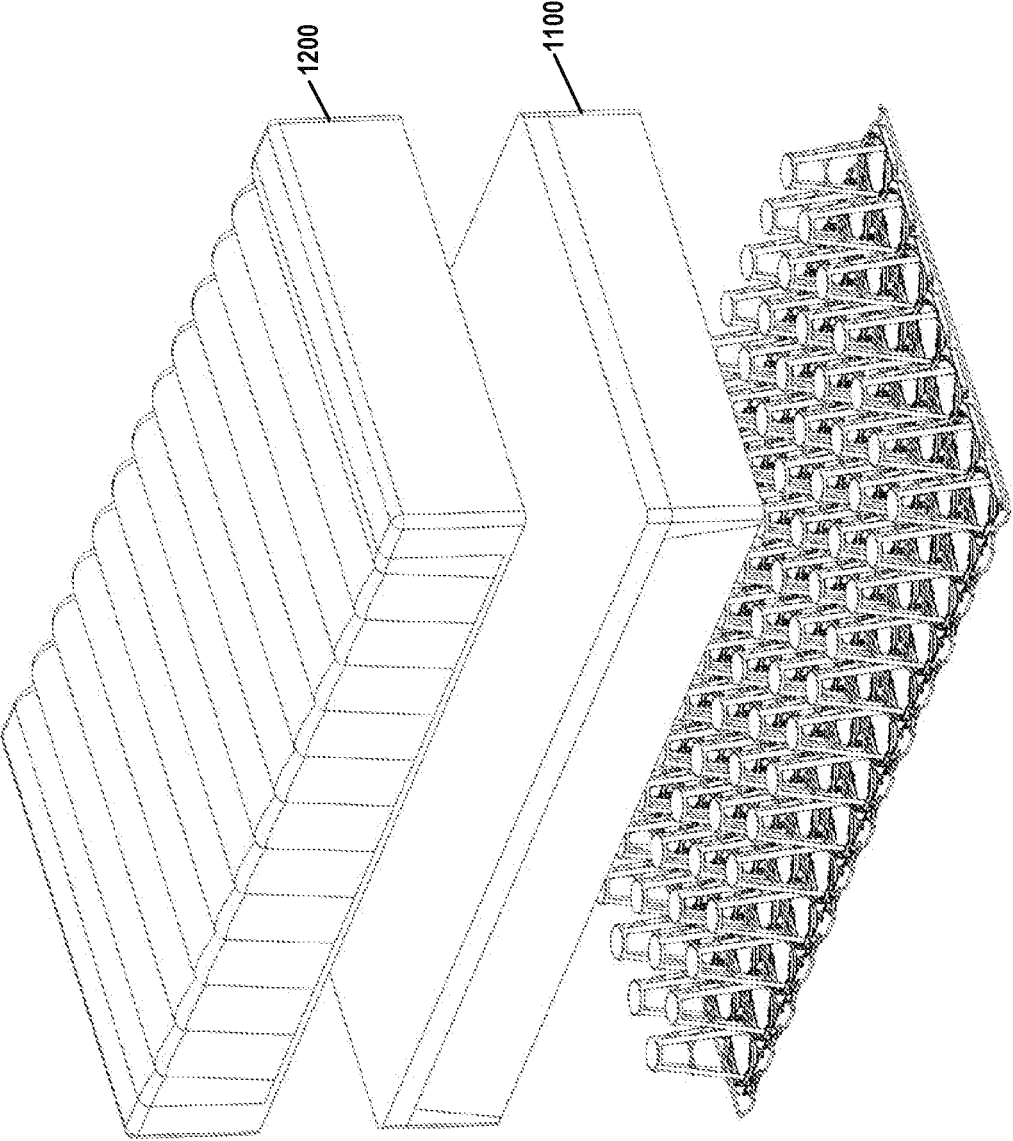

FIG.20C

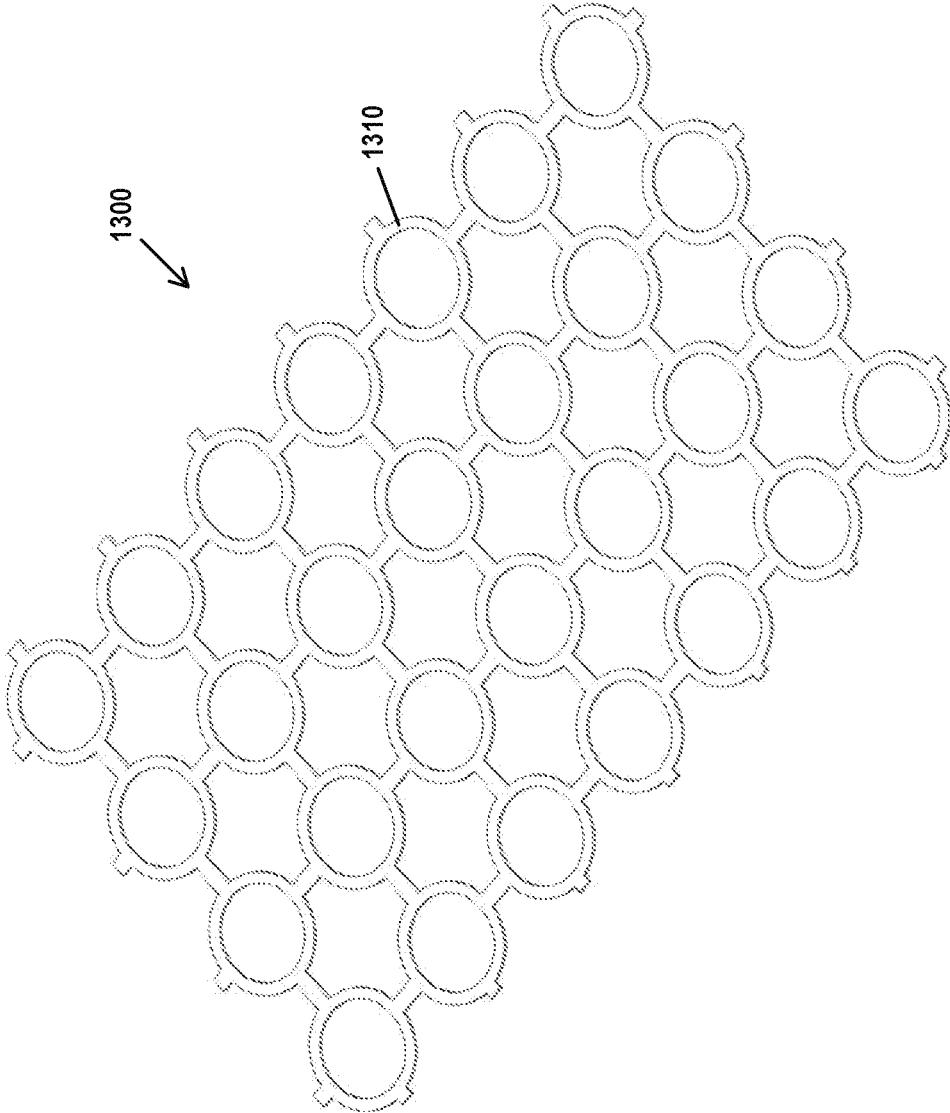

FIG.21A

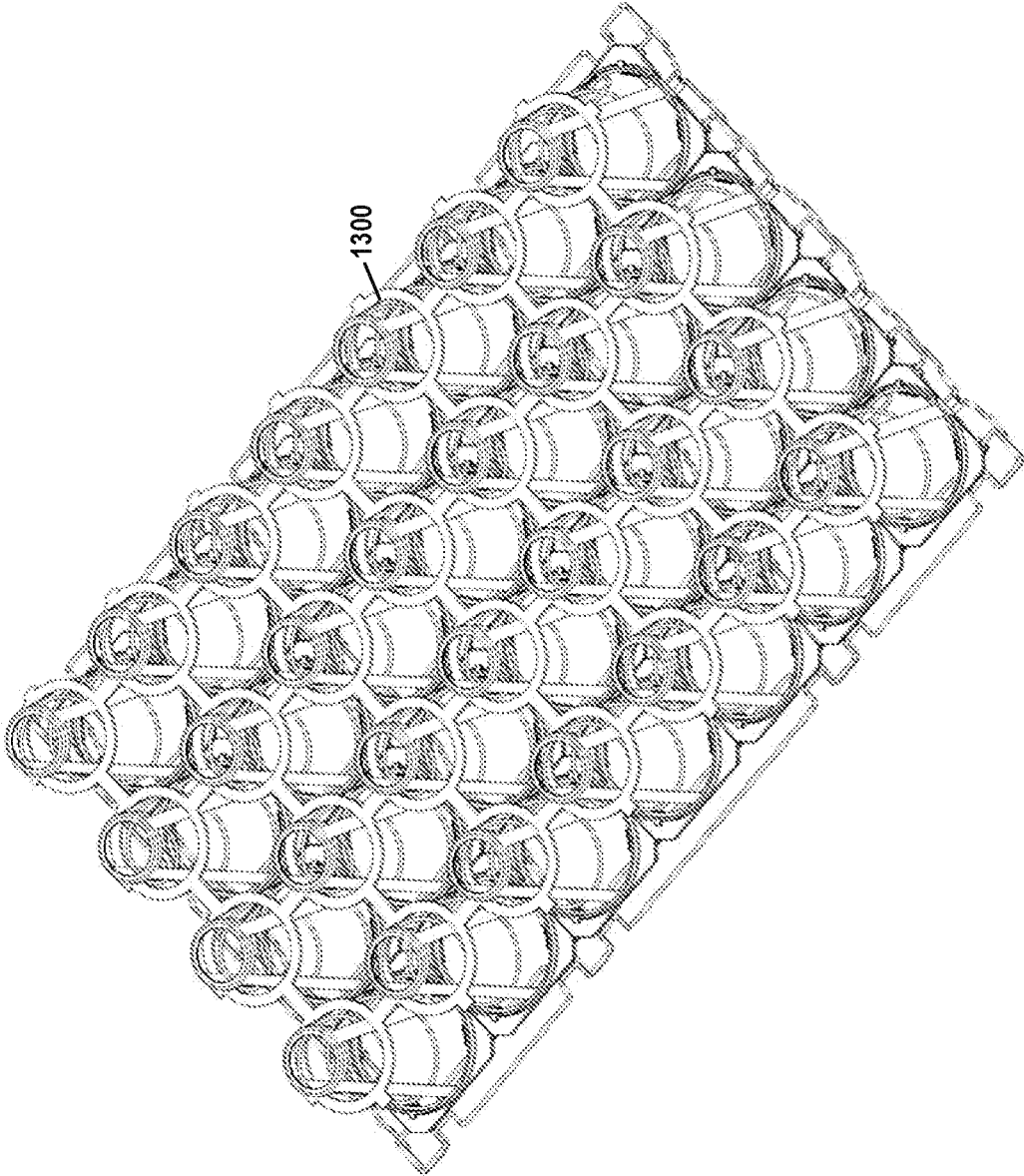

FIG.21B

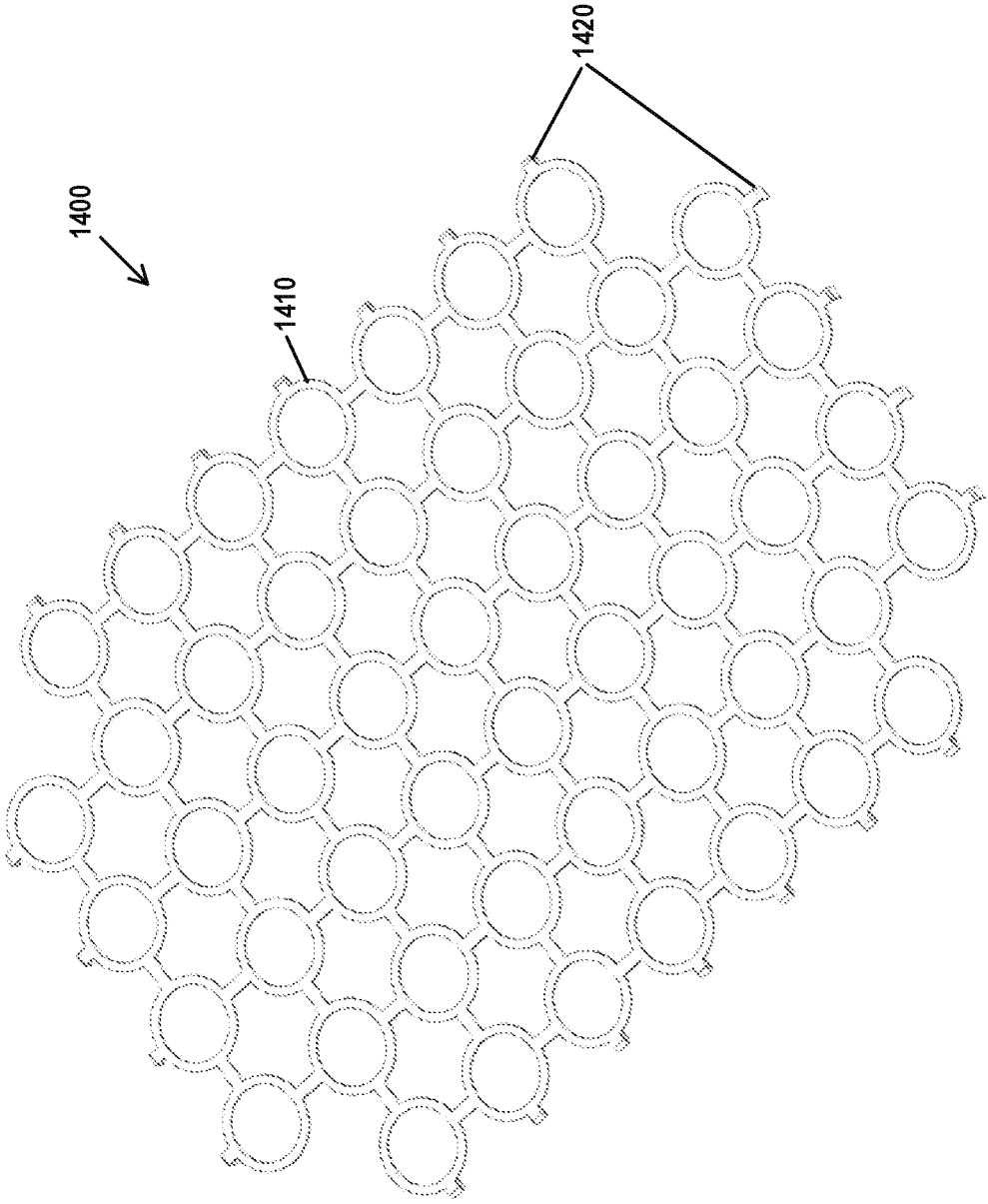

FIG.22A

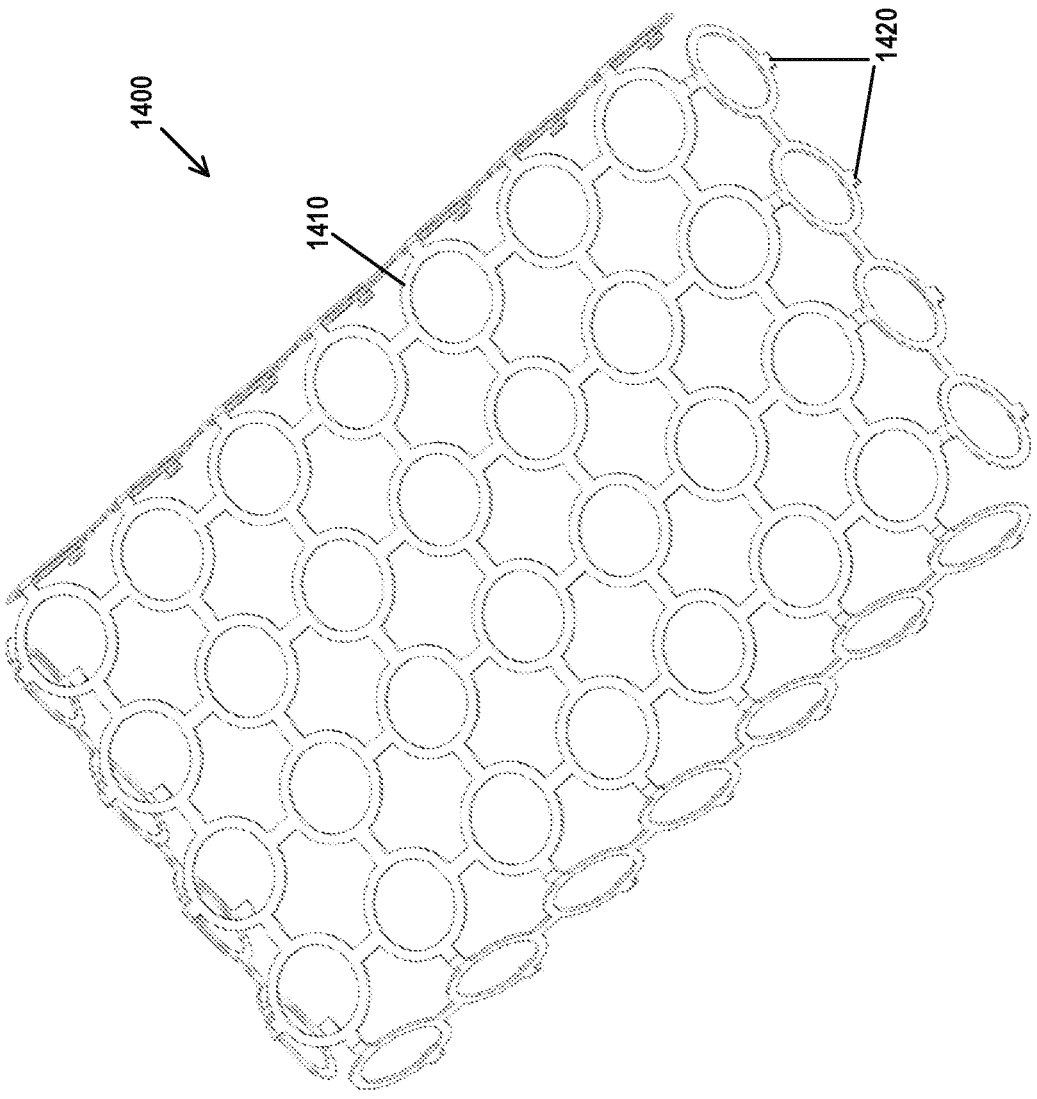

FIG.22B

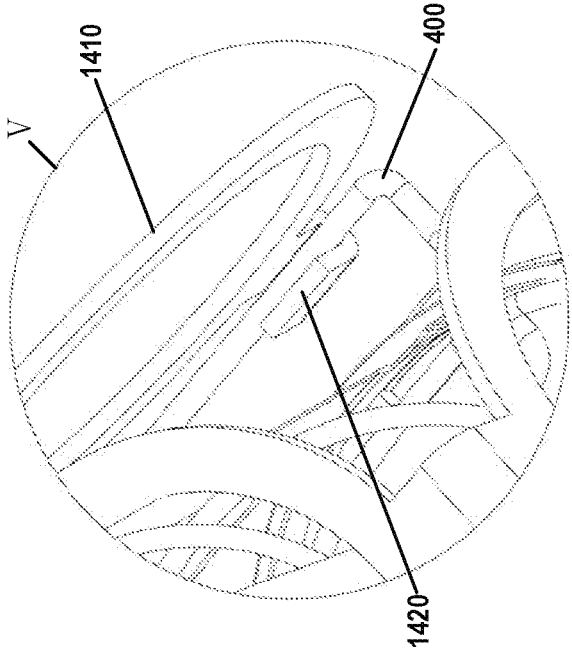

FIG. 22D

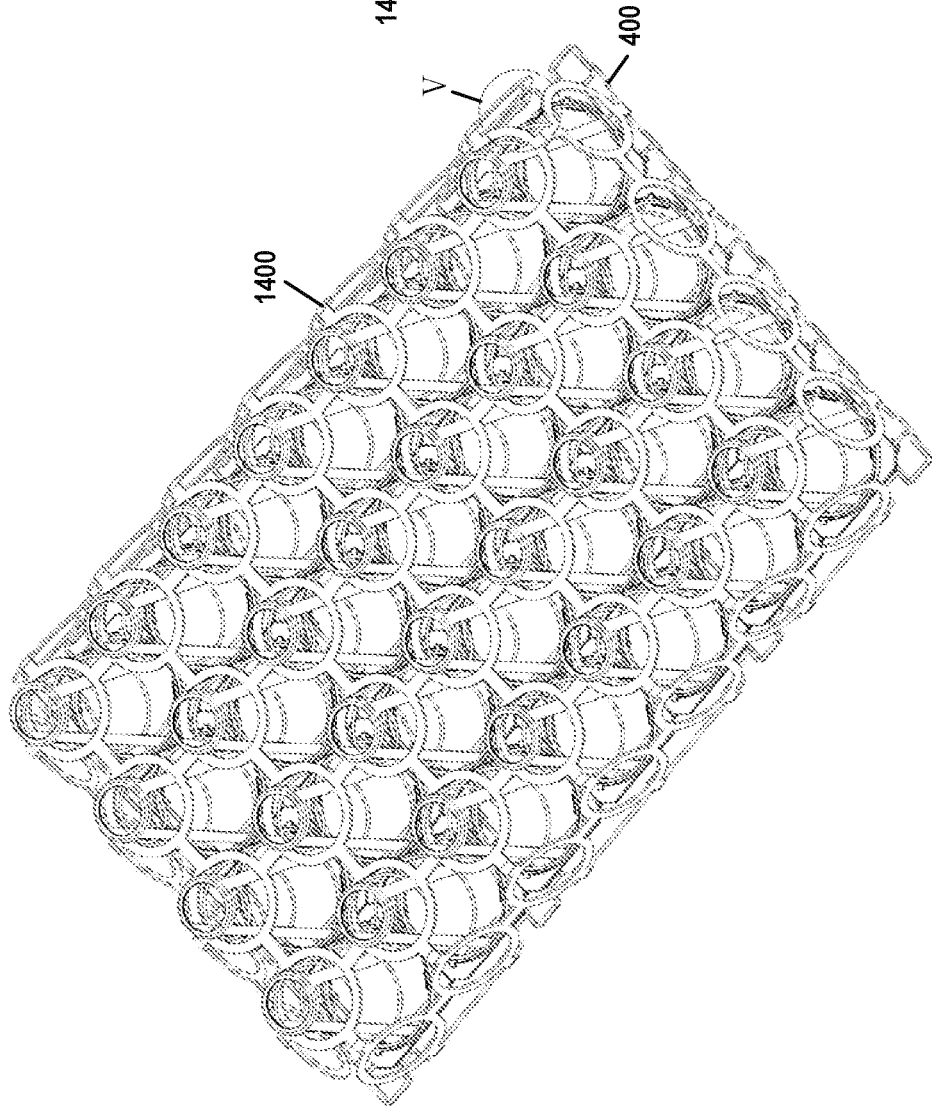

FIG. 22C

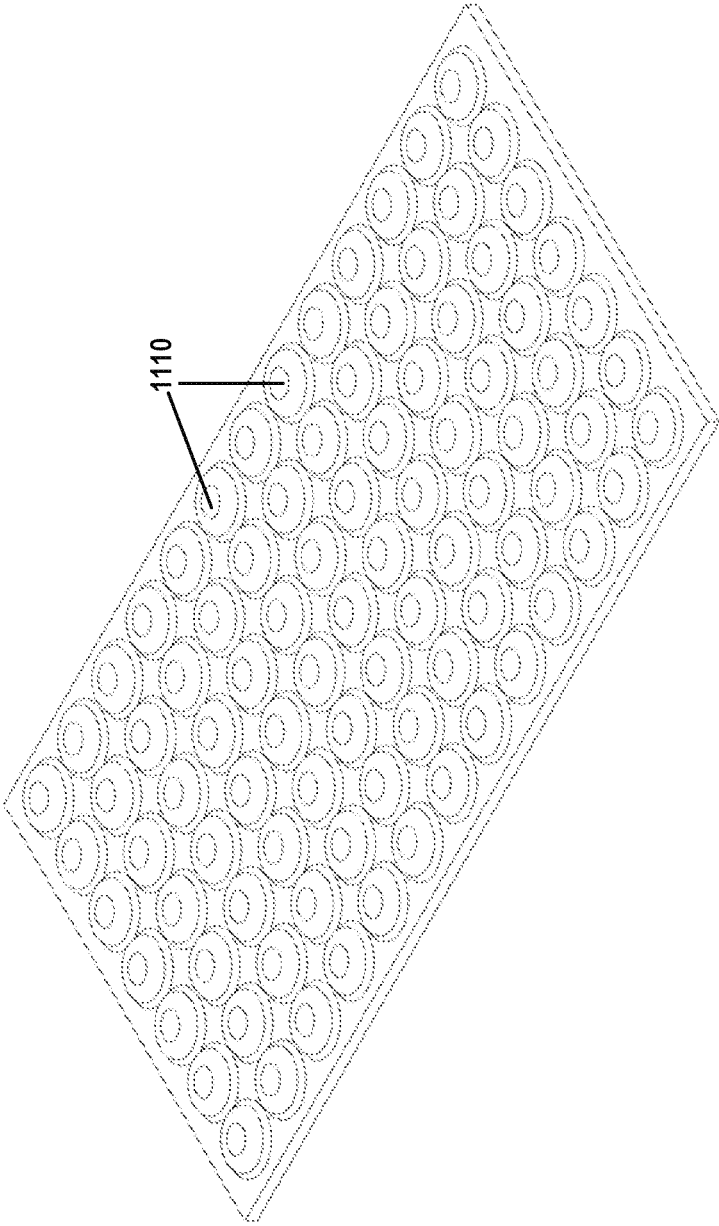

FIG. 23A

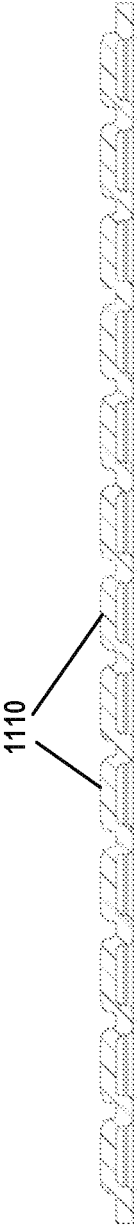

FIG. 23B

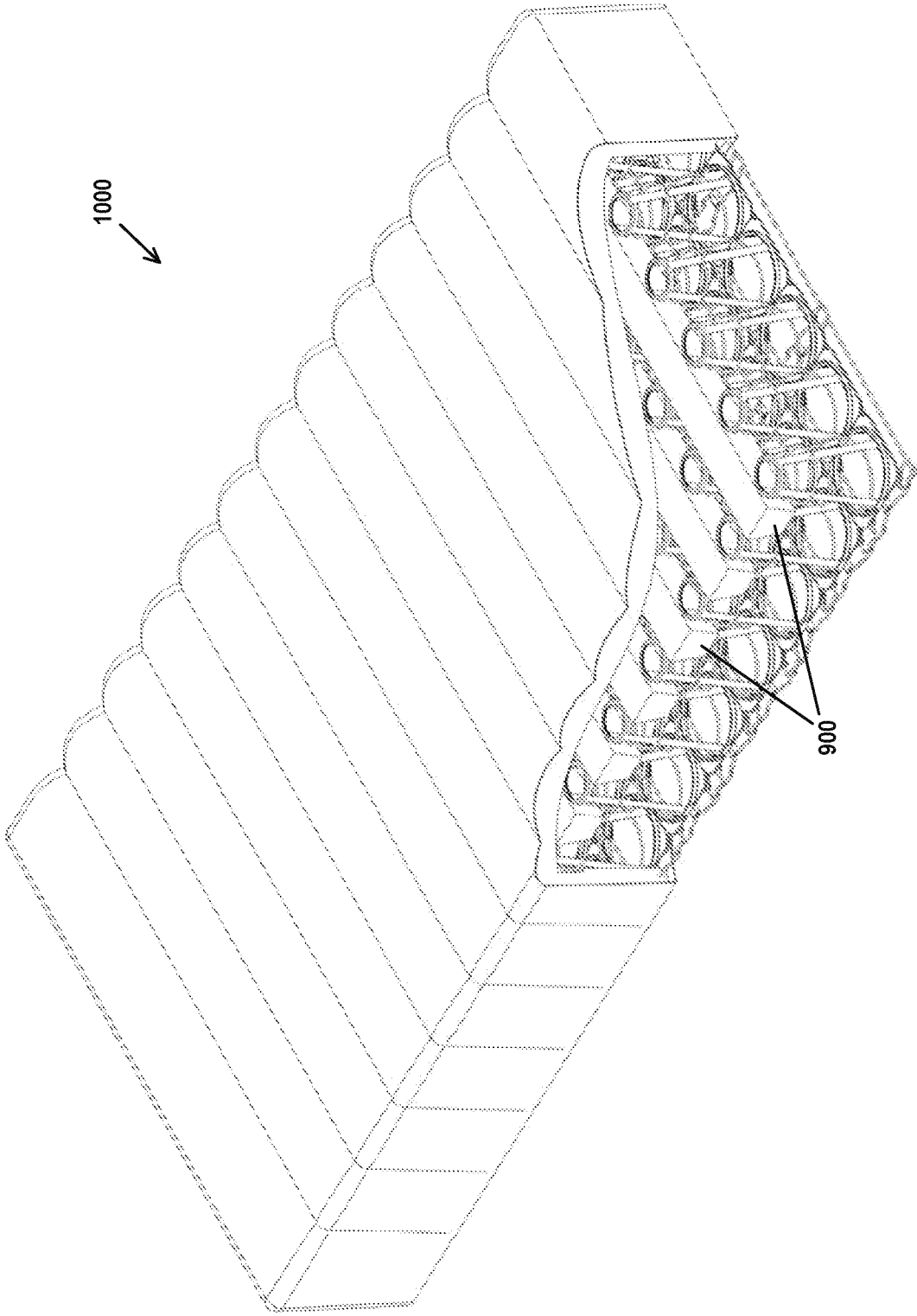

FIG.24A

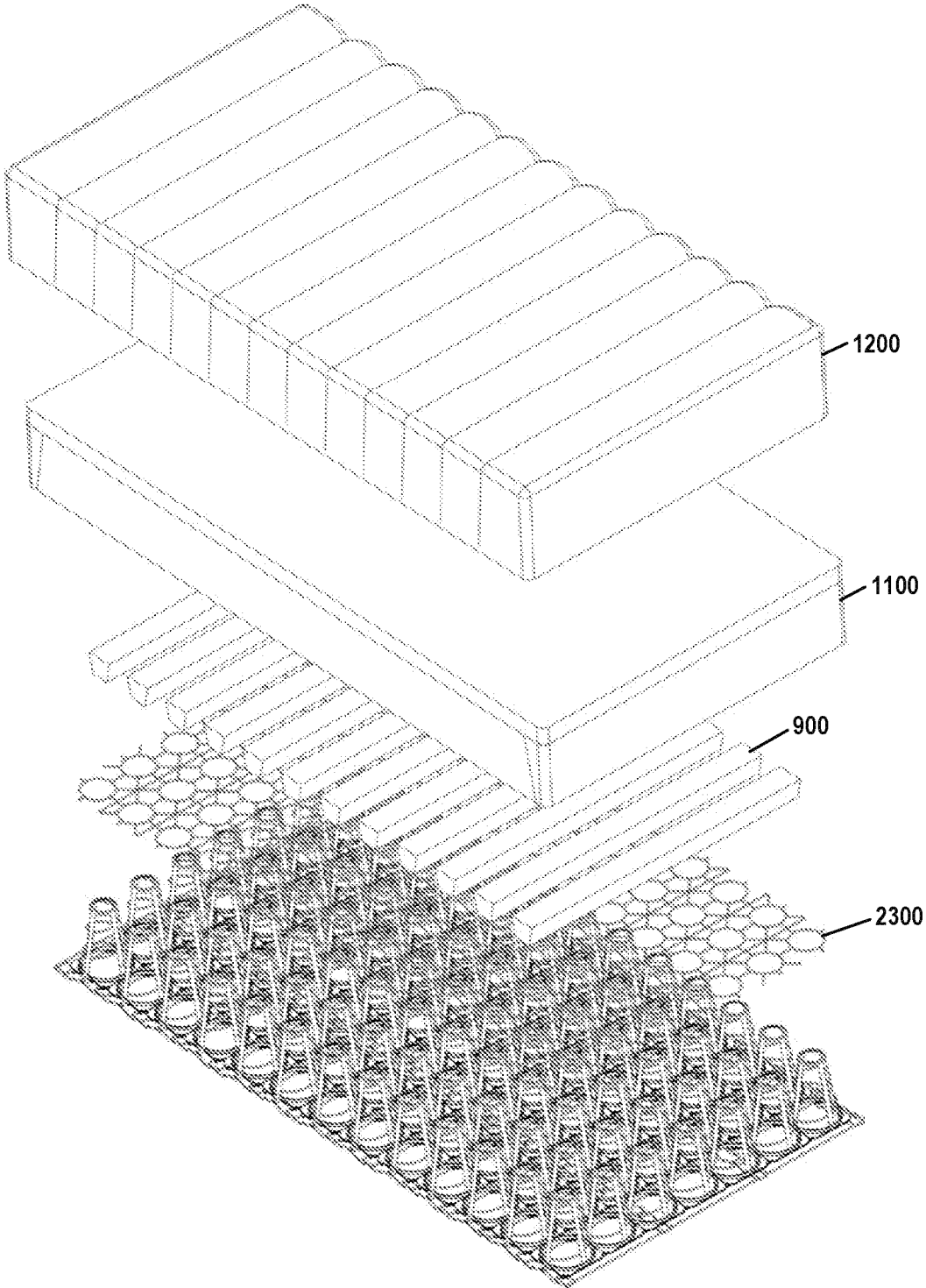

FIG.24B

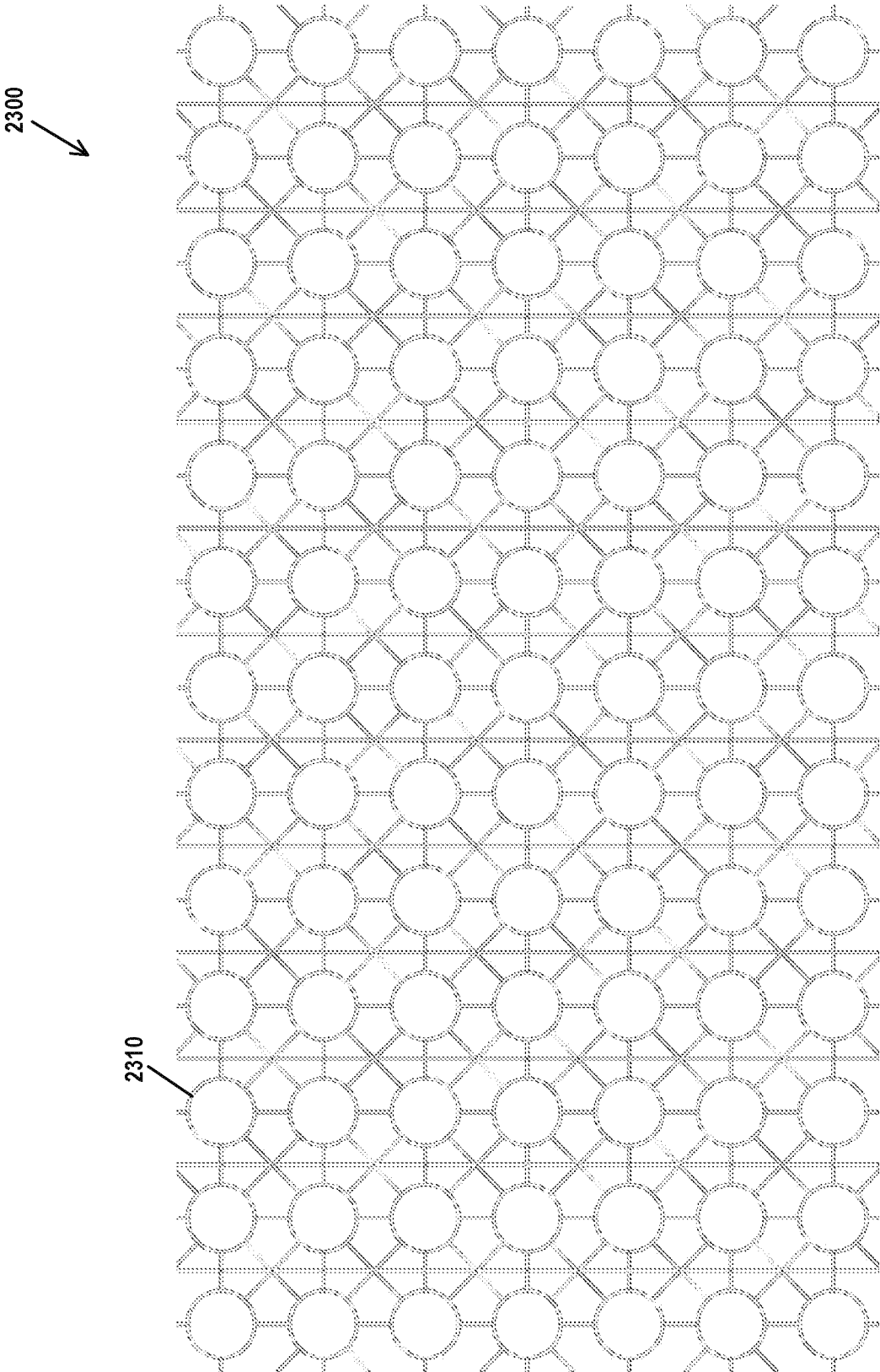

FIG.24C

1000

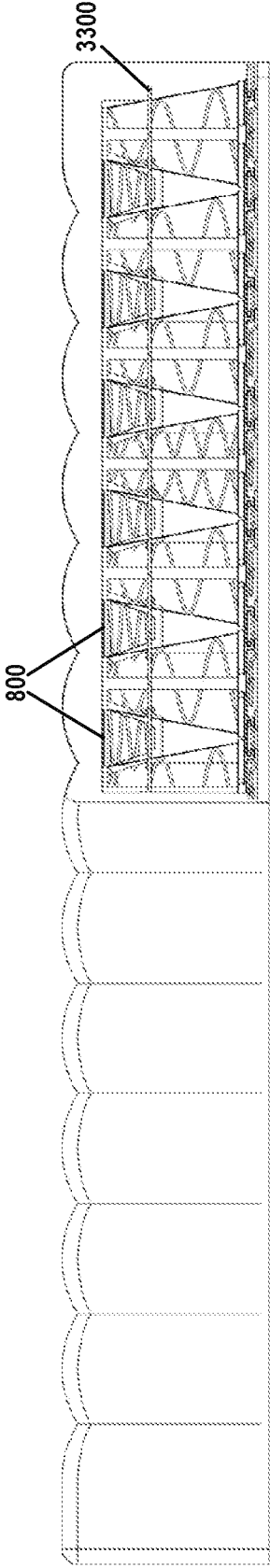

FIG.25A

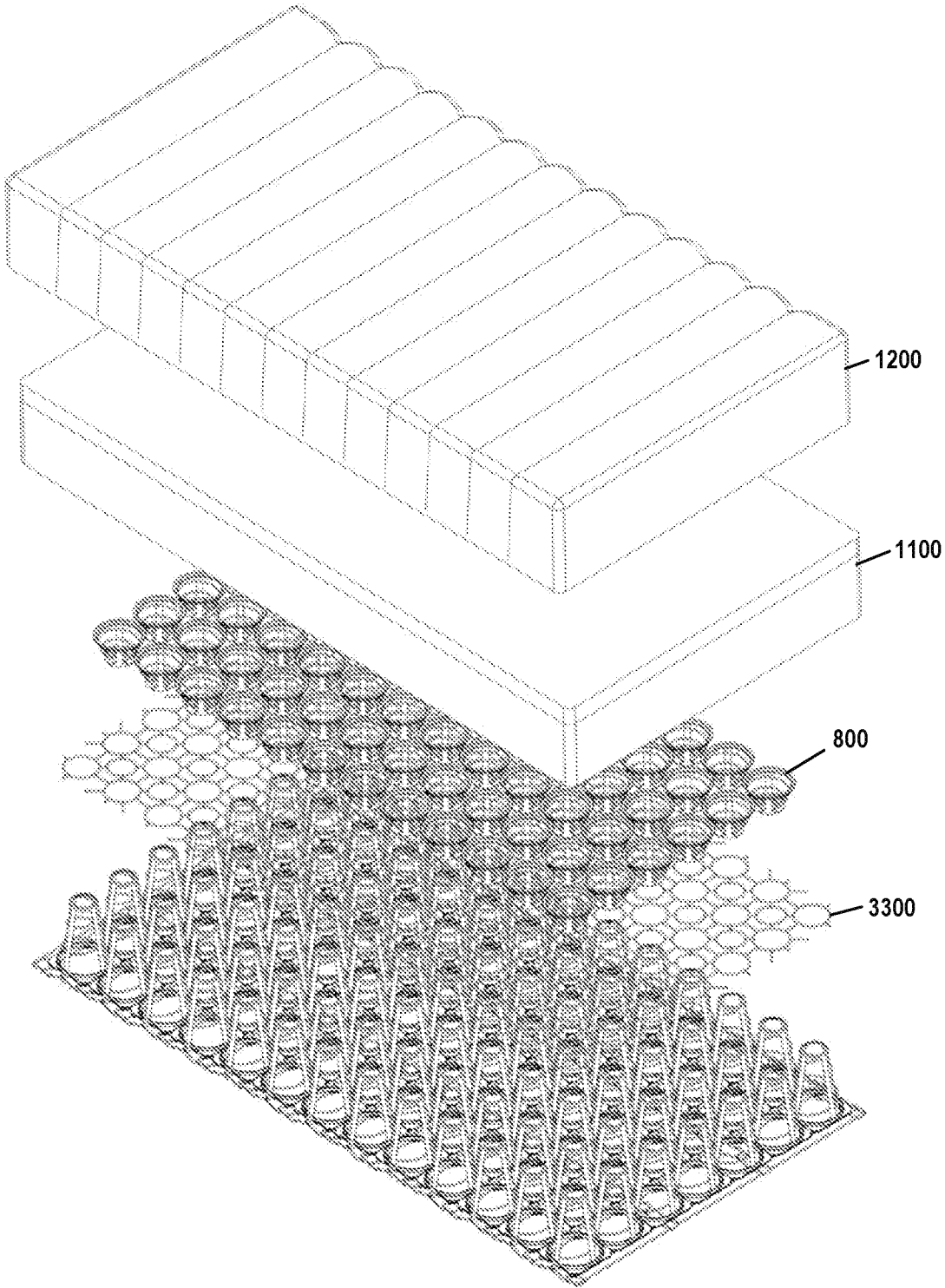

FIG.25B

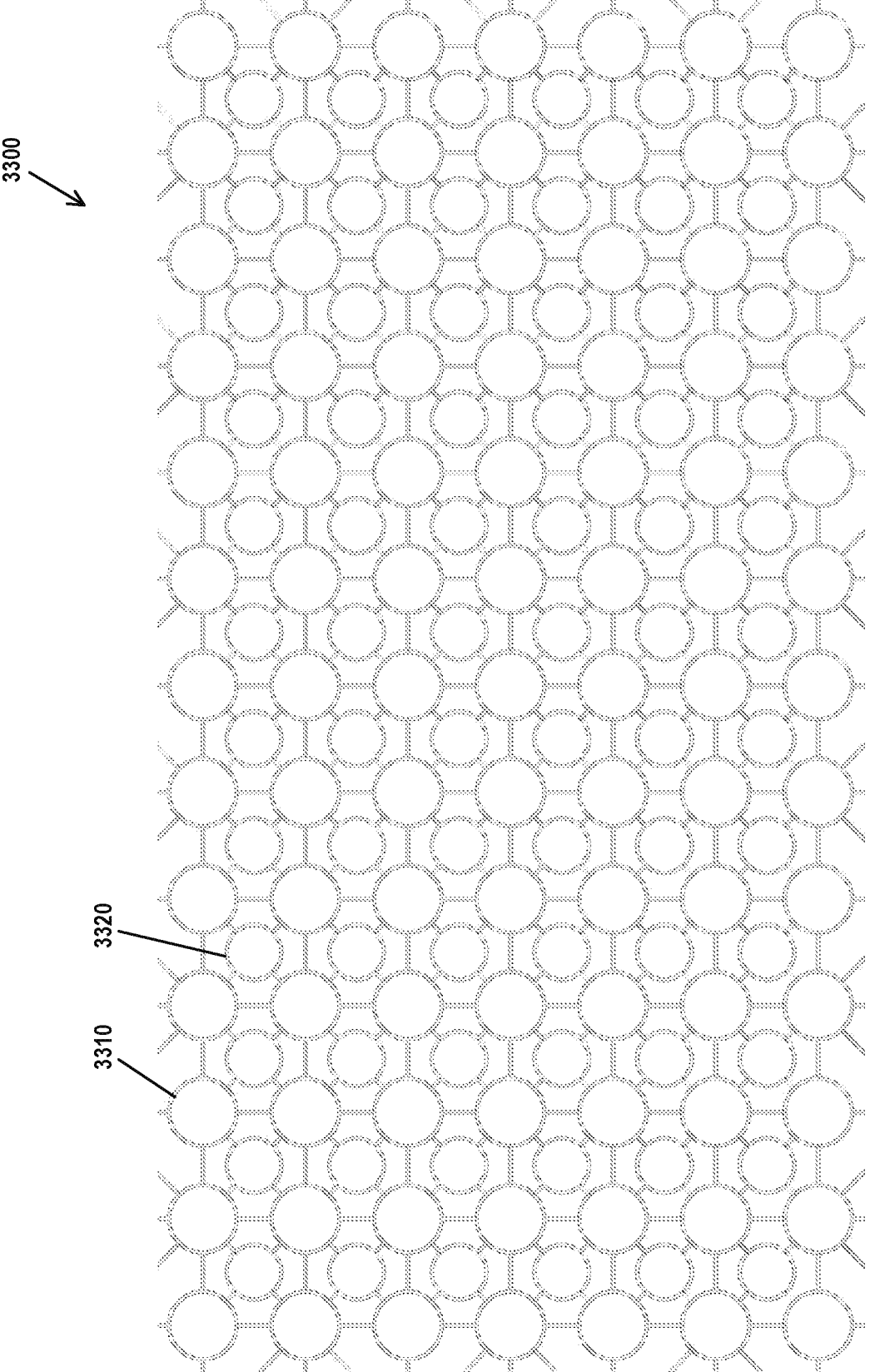

FIG.25C

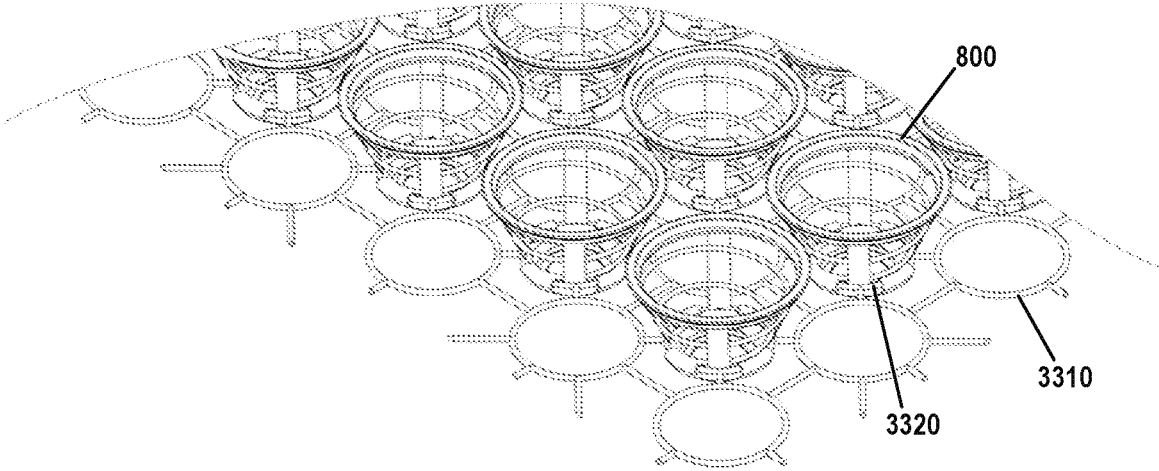

FIG. 25D

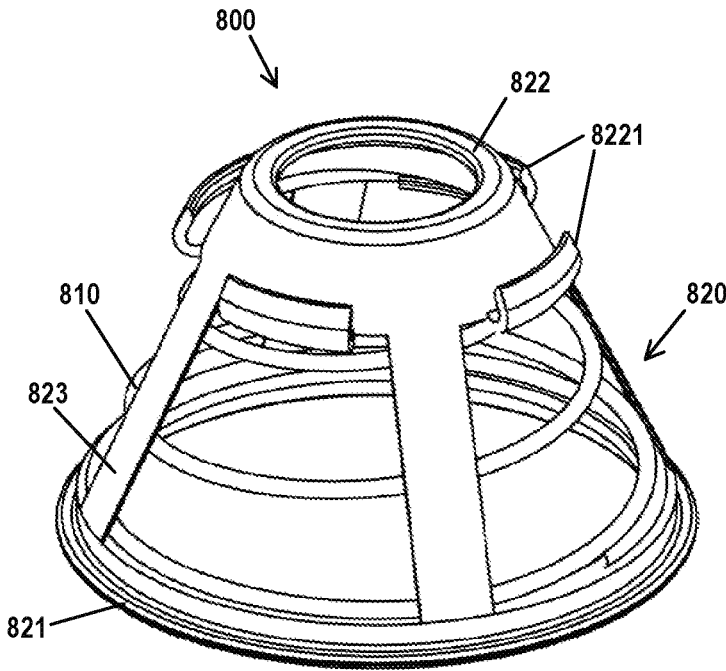

FIG. 25E

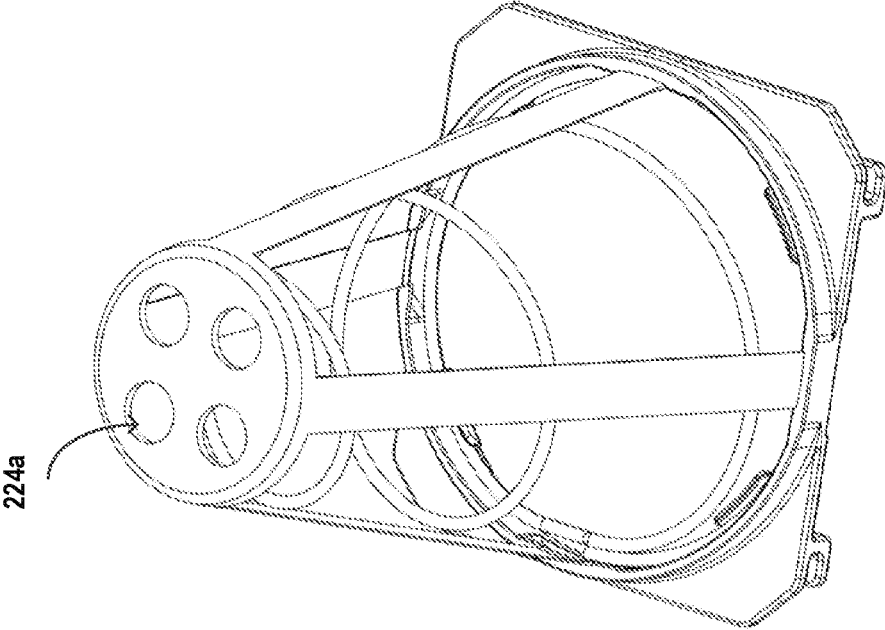

FIG. 26A

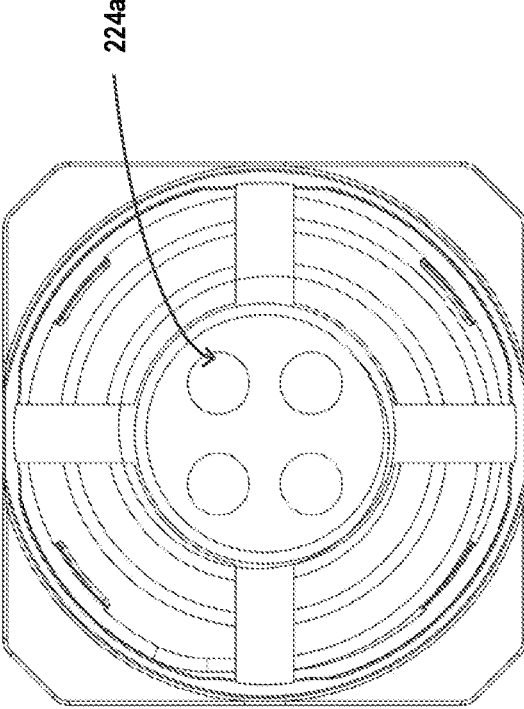
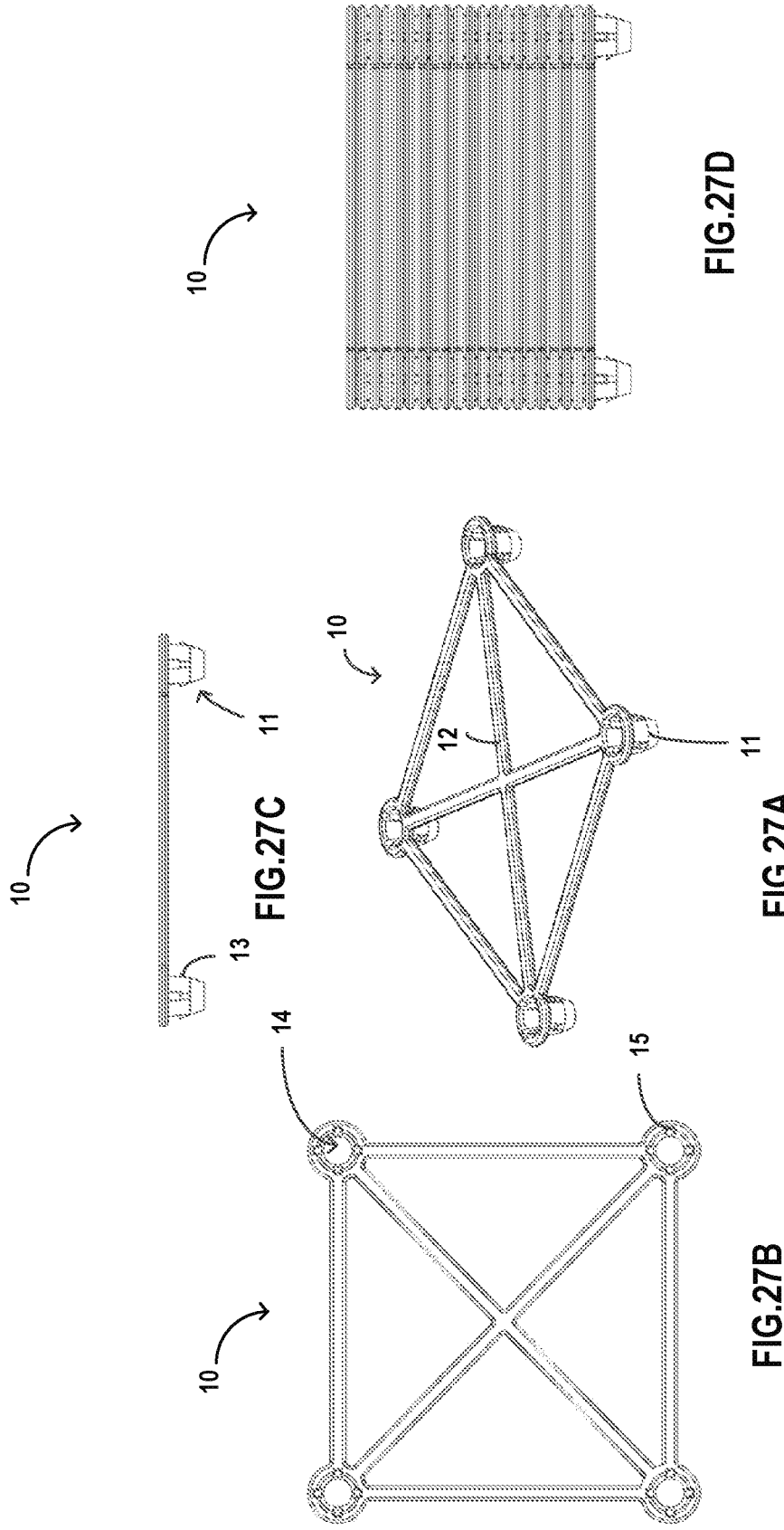

FIG. 26B



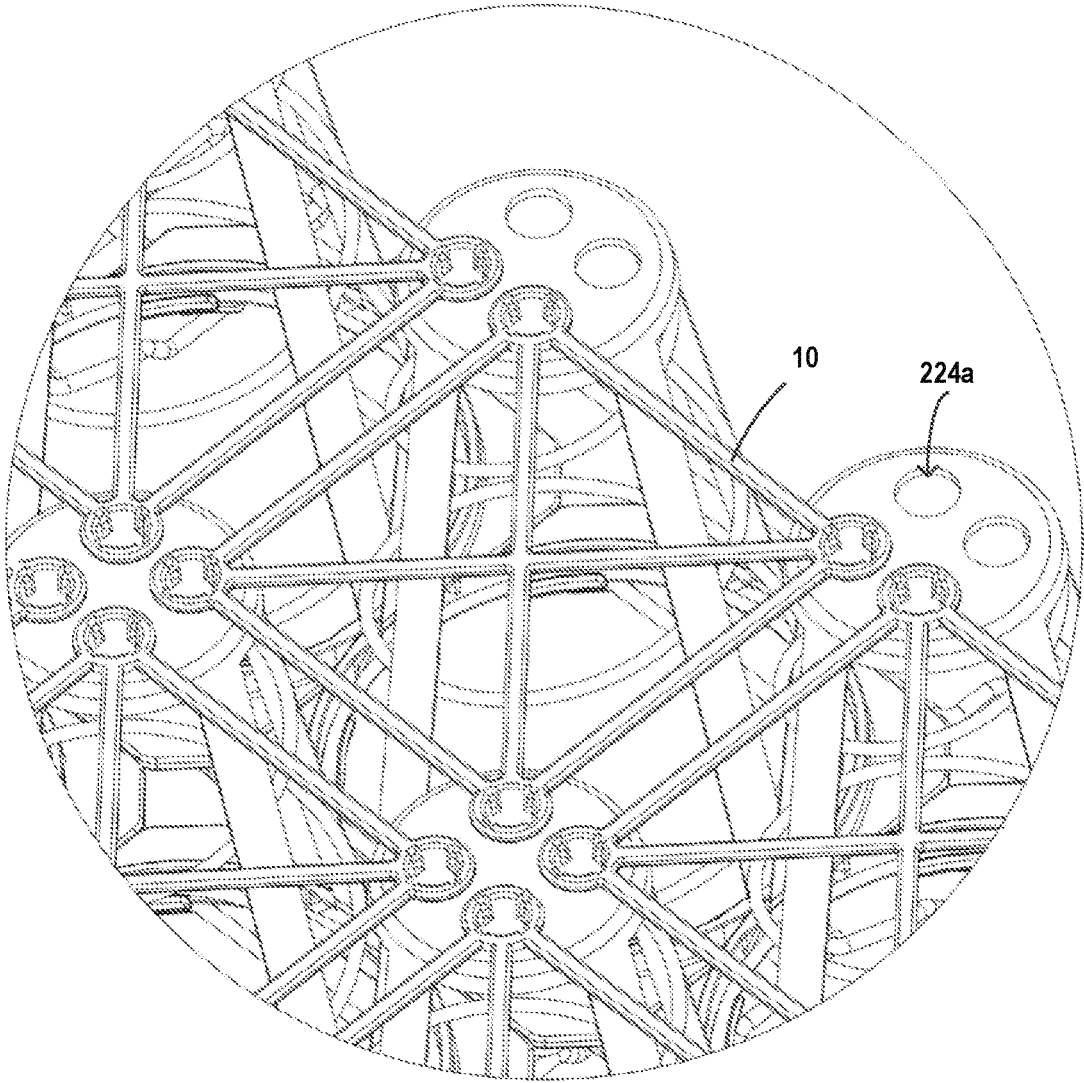

FIG.27E

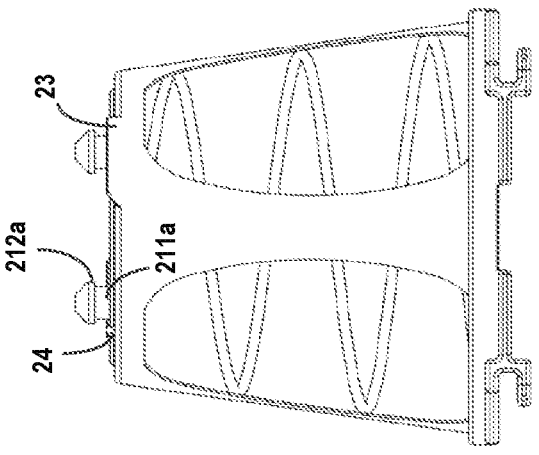

FIG. 28B

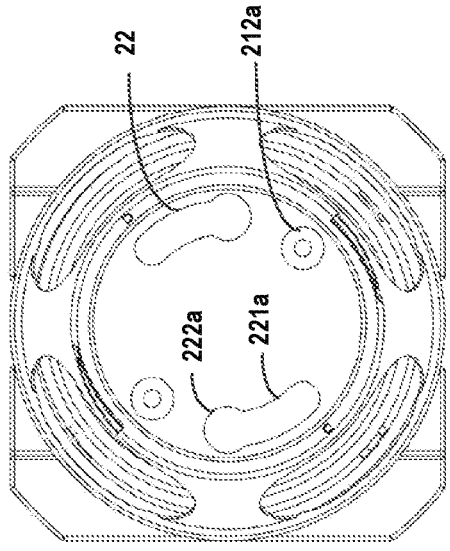

FIG. 28C

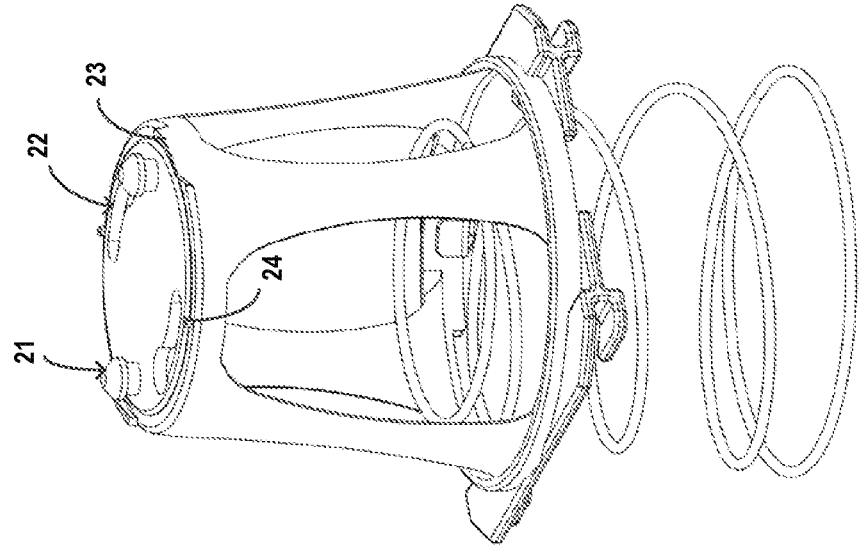
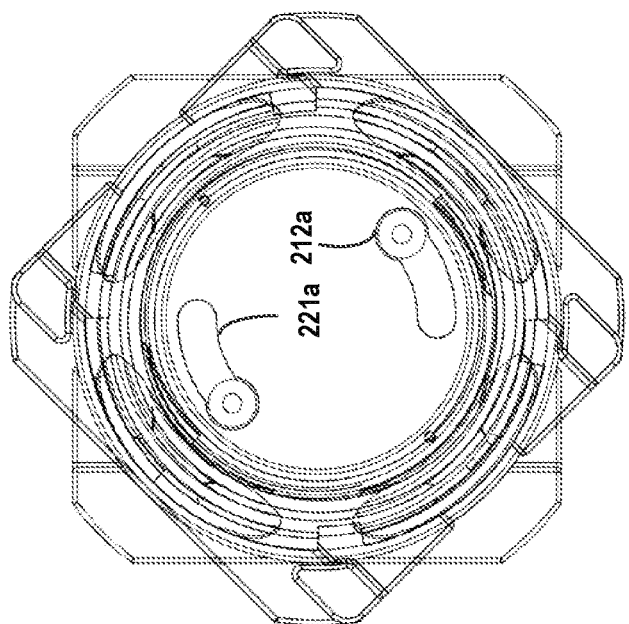
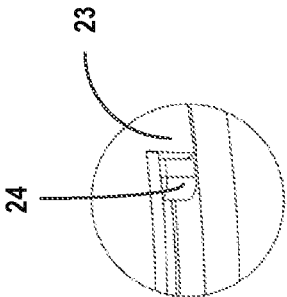
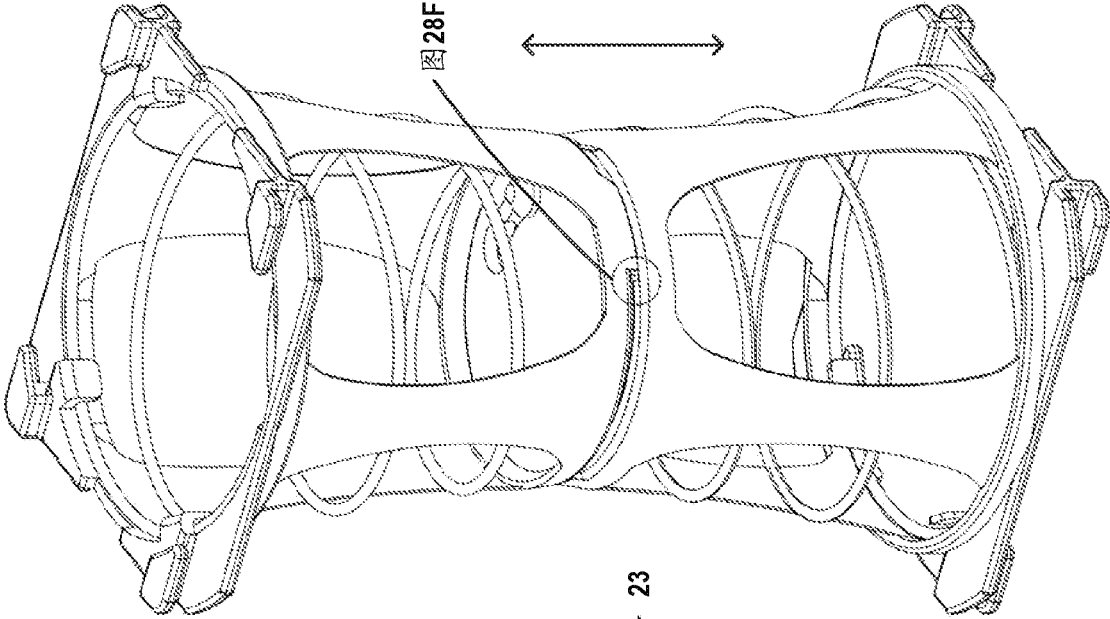

FIG. 28A



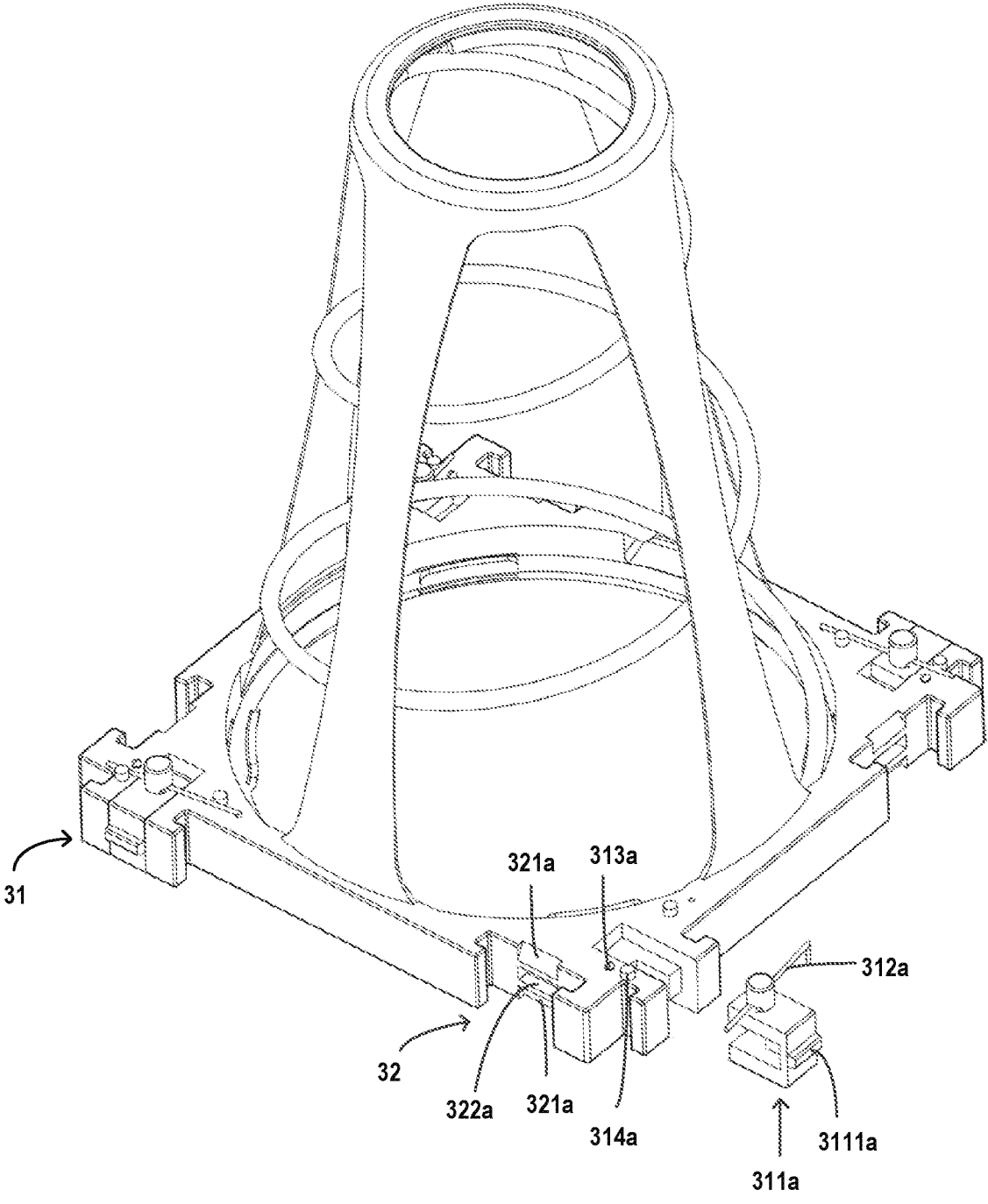

FIG.29A

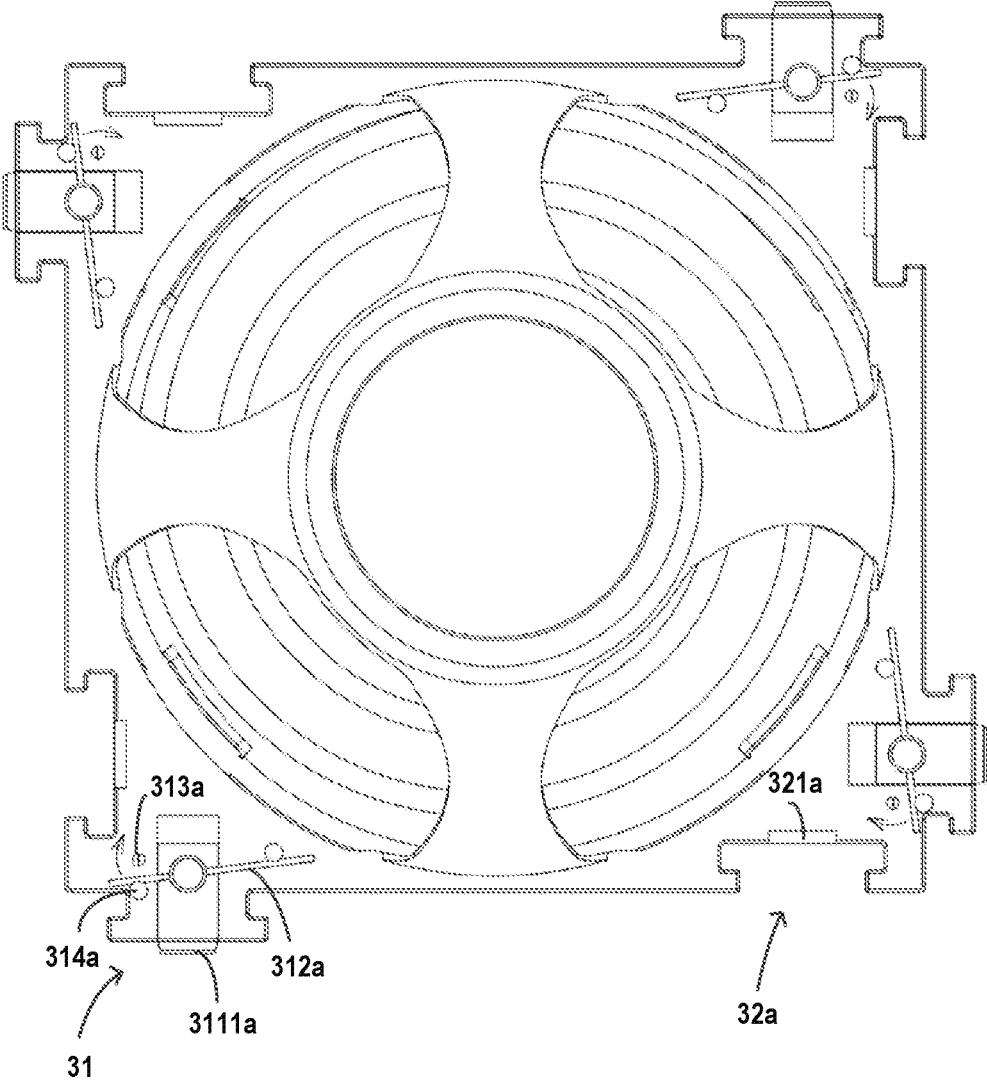

FIG.29B

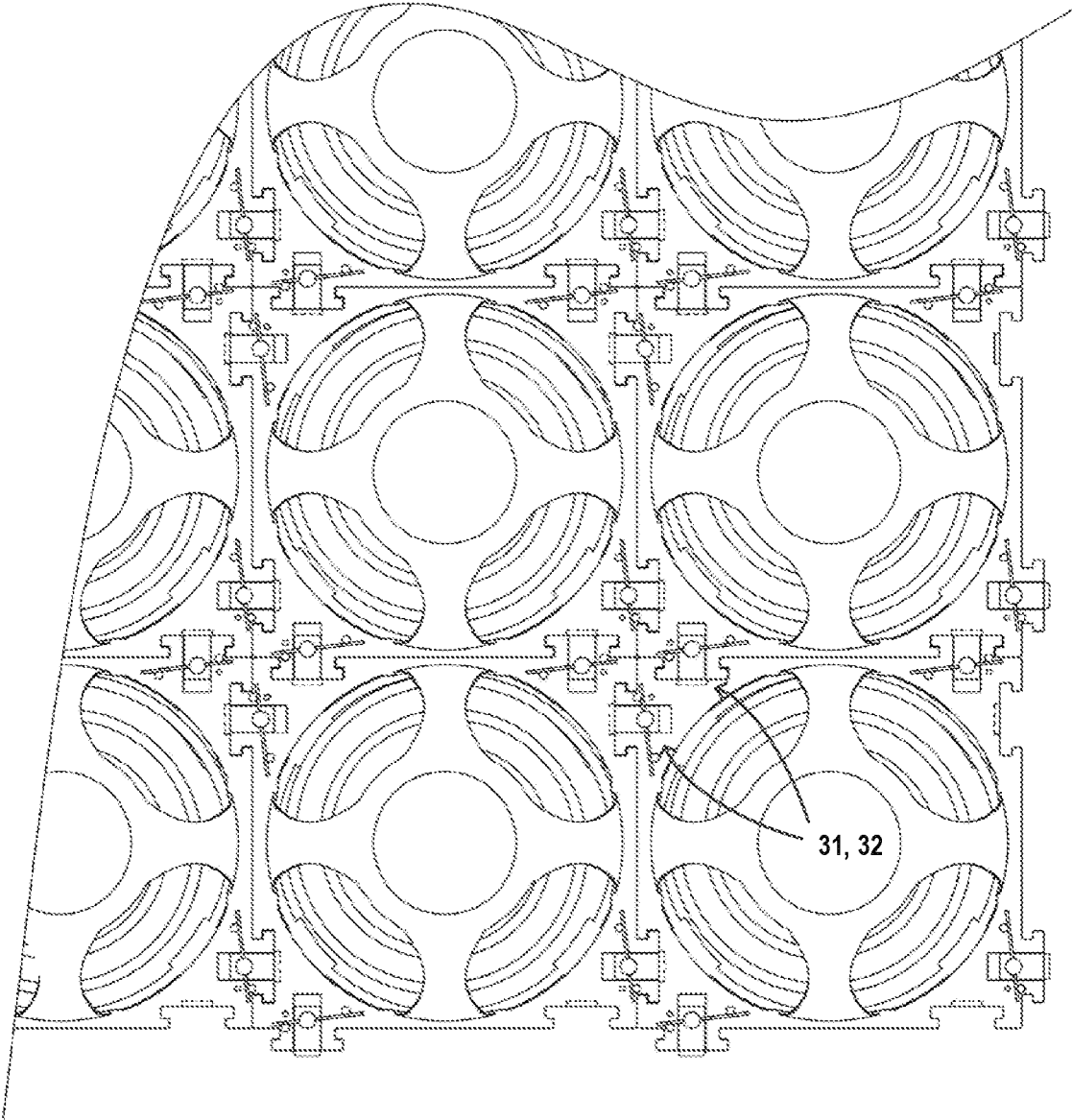

FIG.29C

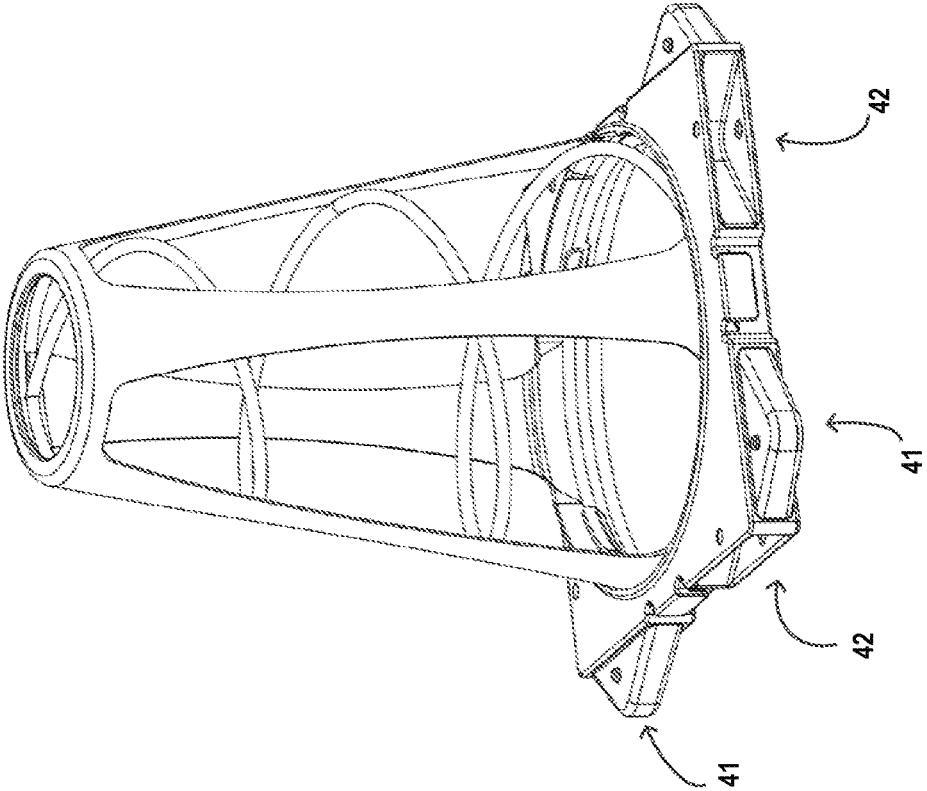

FIG.30A

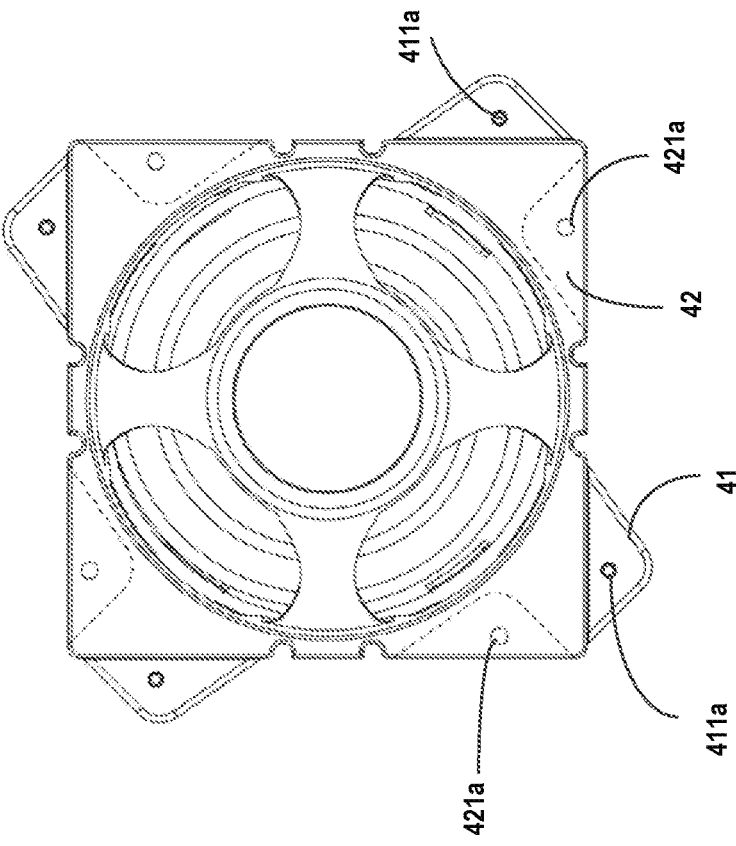

FIG.30B

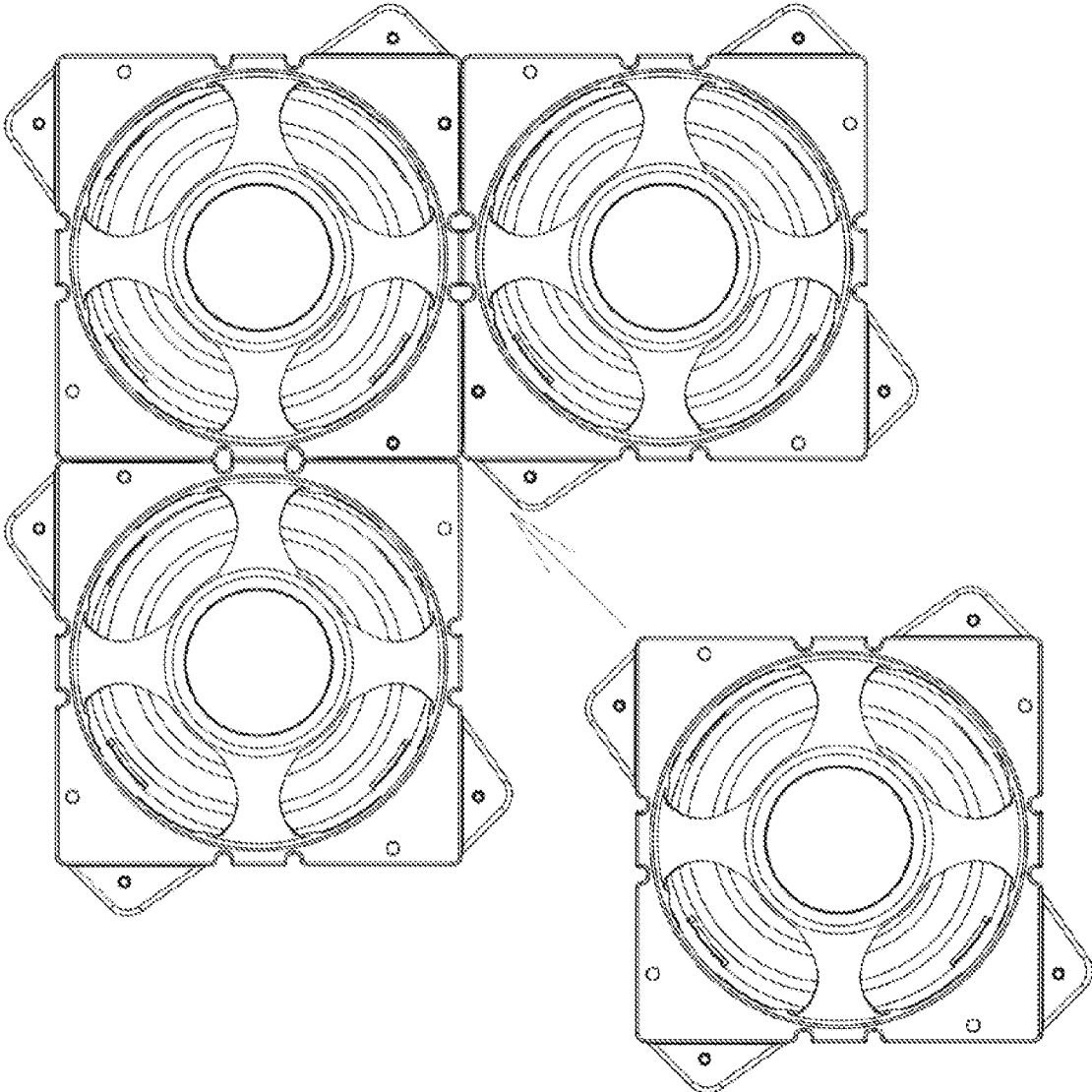

FIG.30C

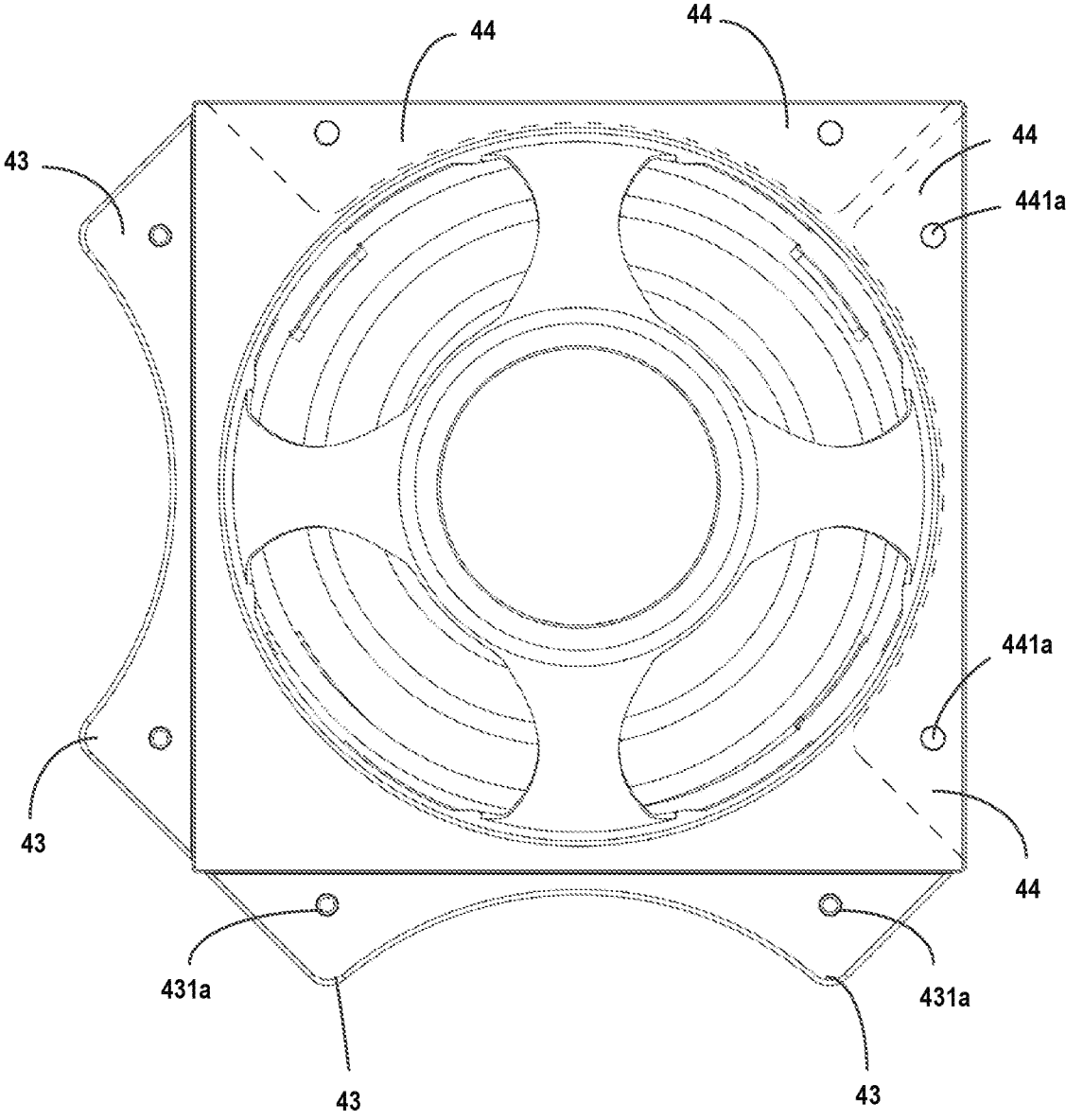

FIG.30D

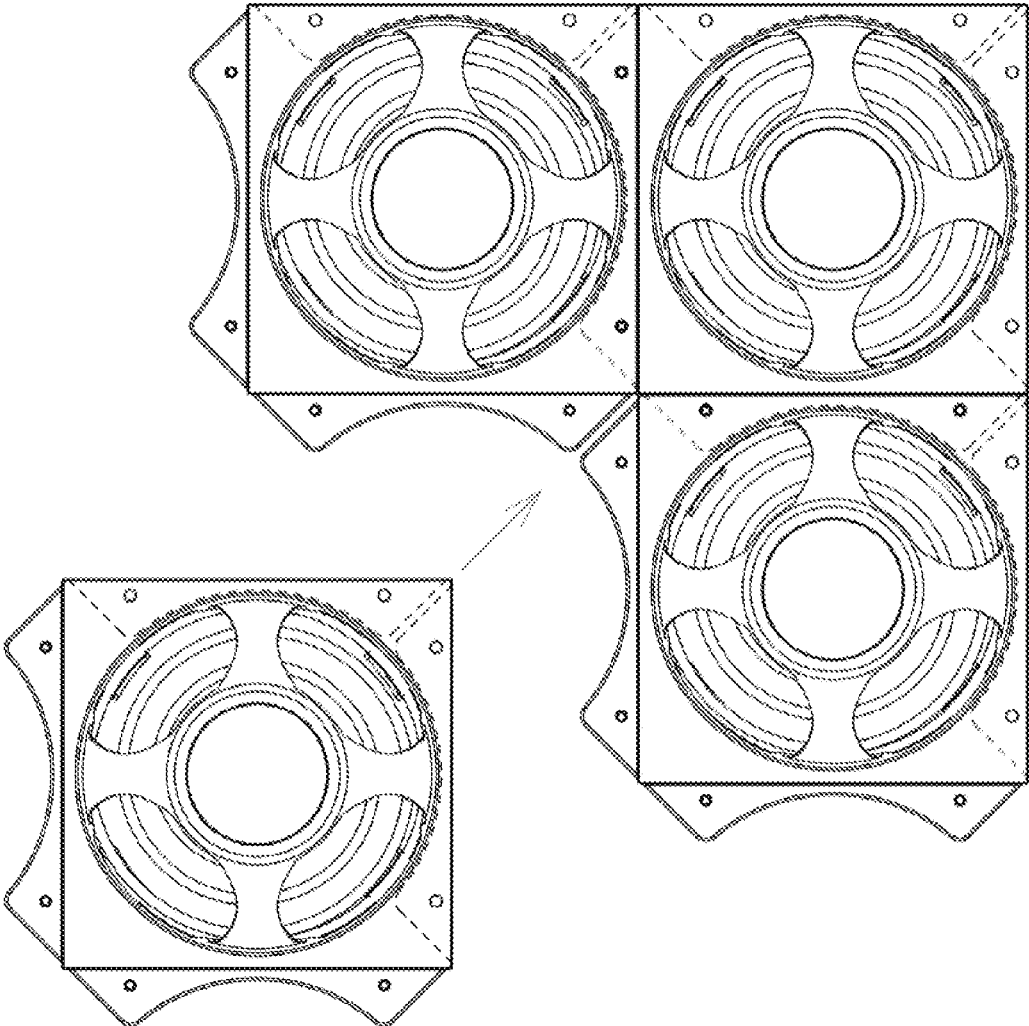

FIG.30E

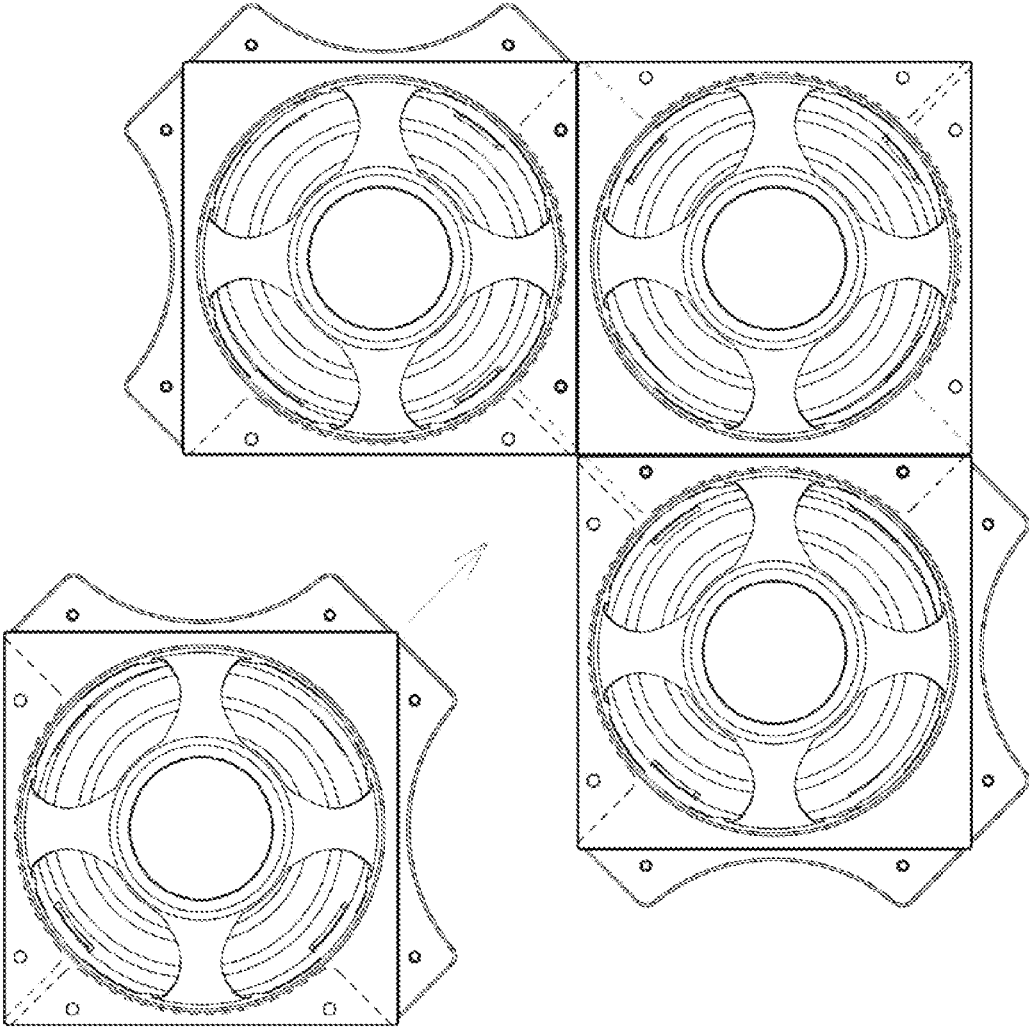

FIG.30F

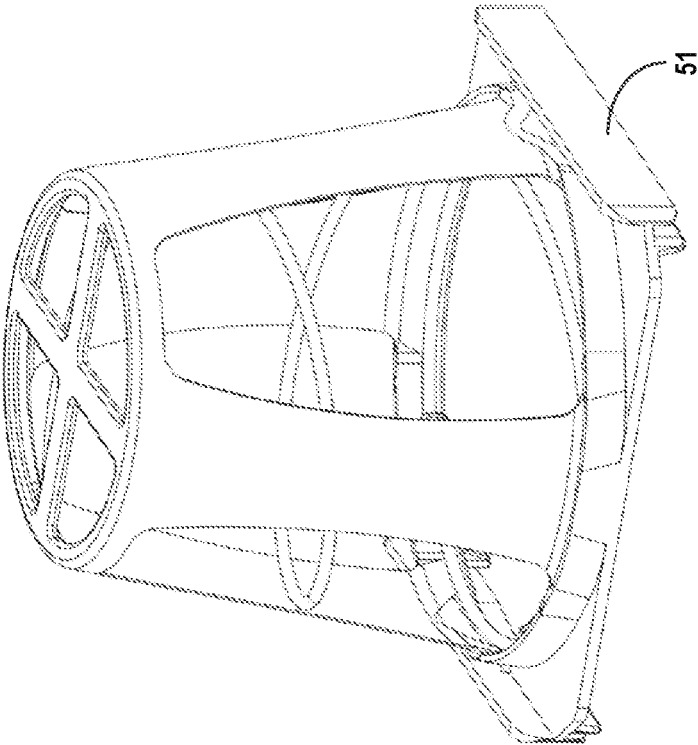

FIG.31A

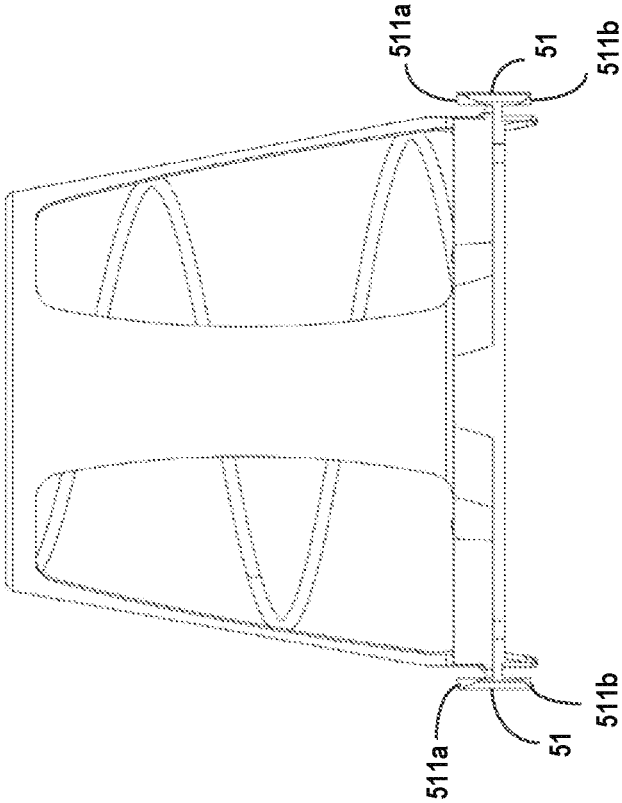

FIG.31B

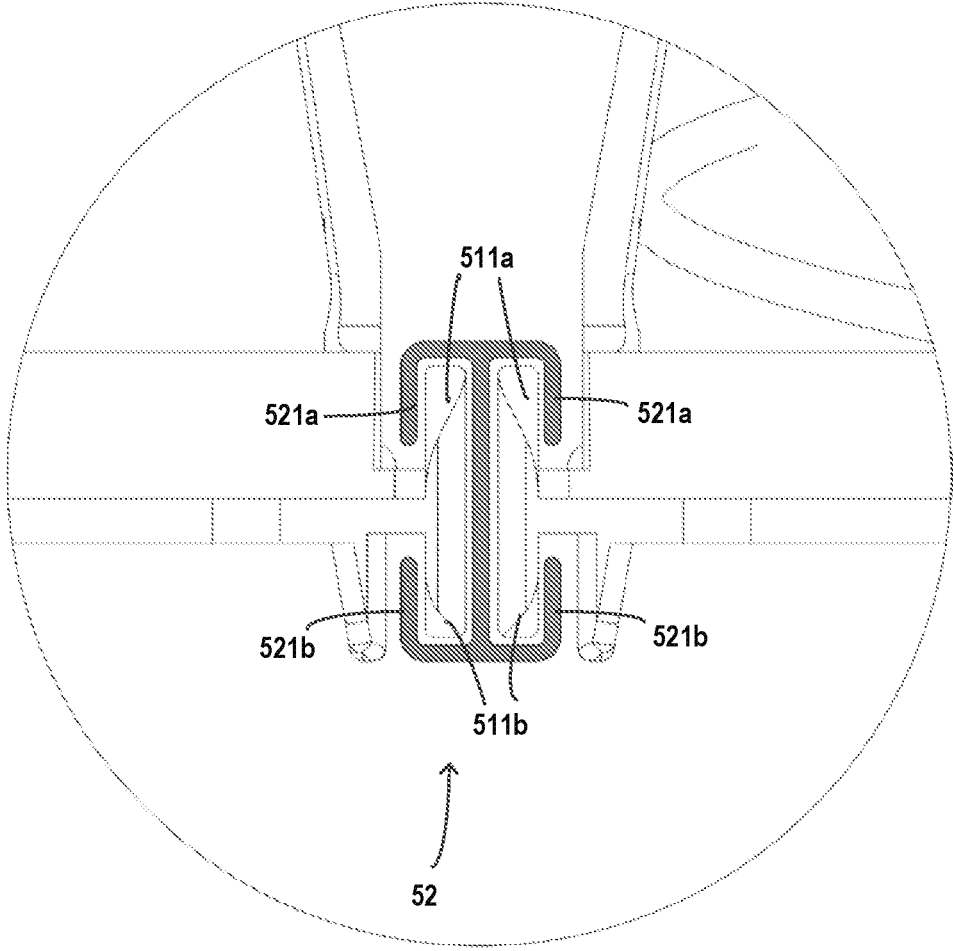

FIG.31C

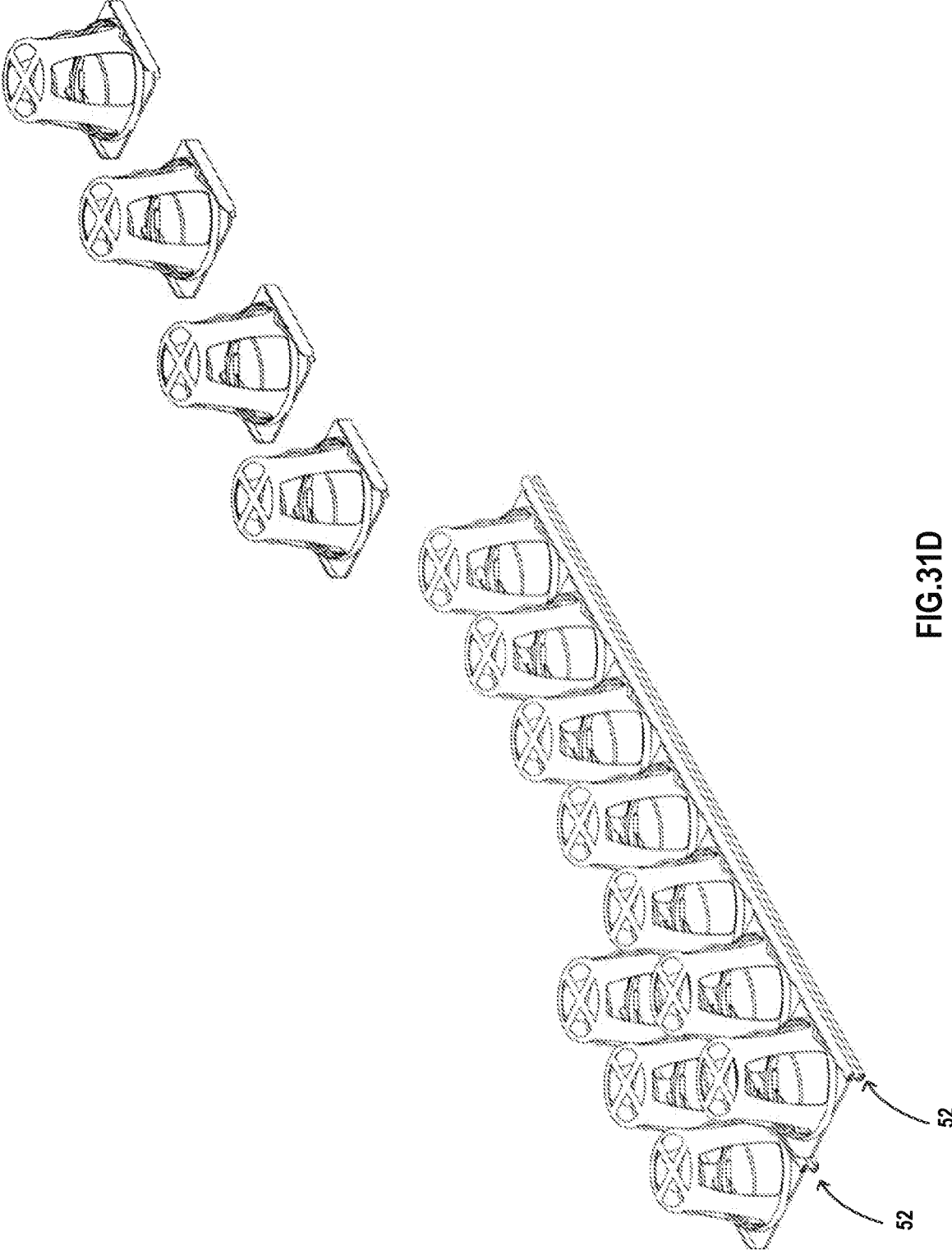

FIG.31D

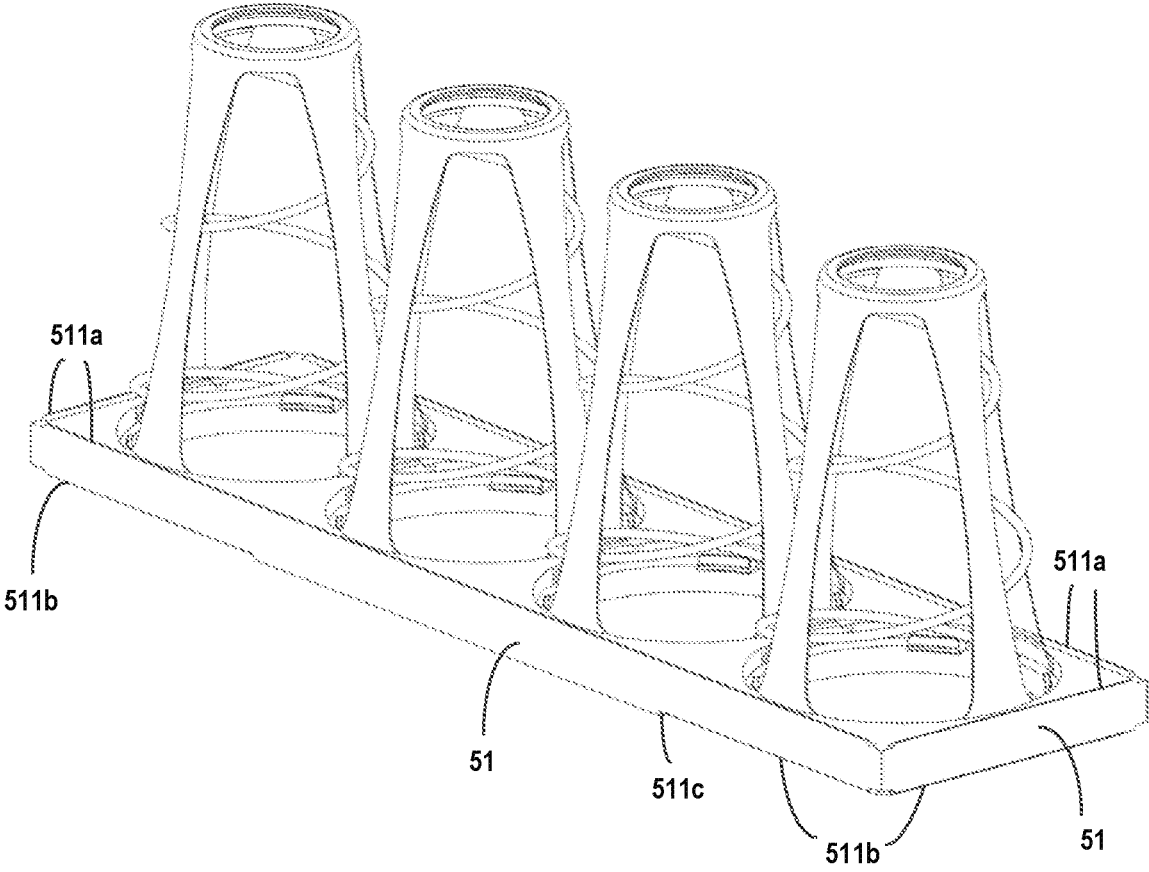

FIG.31E

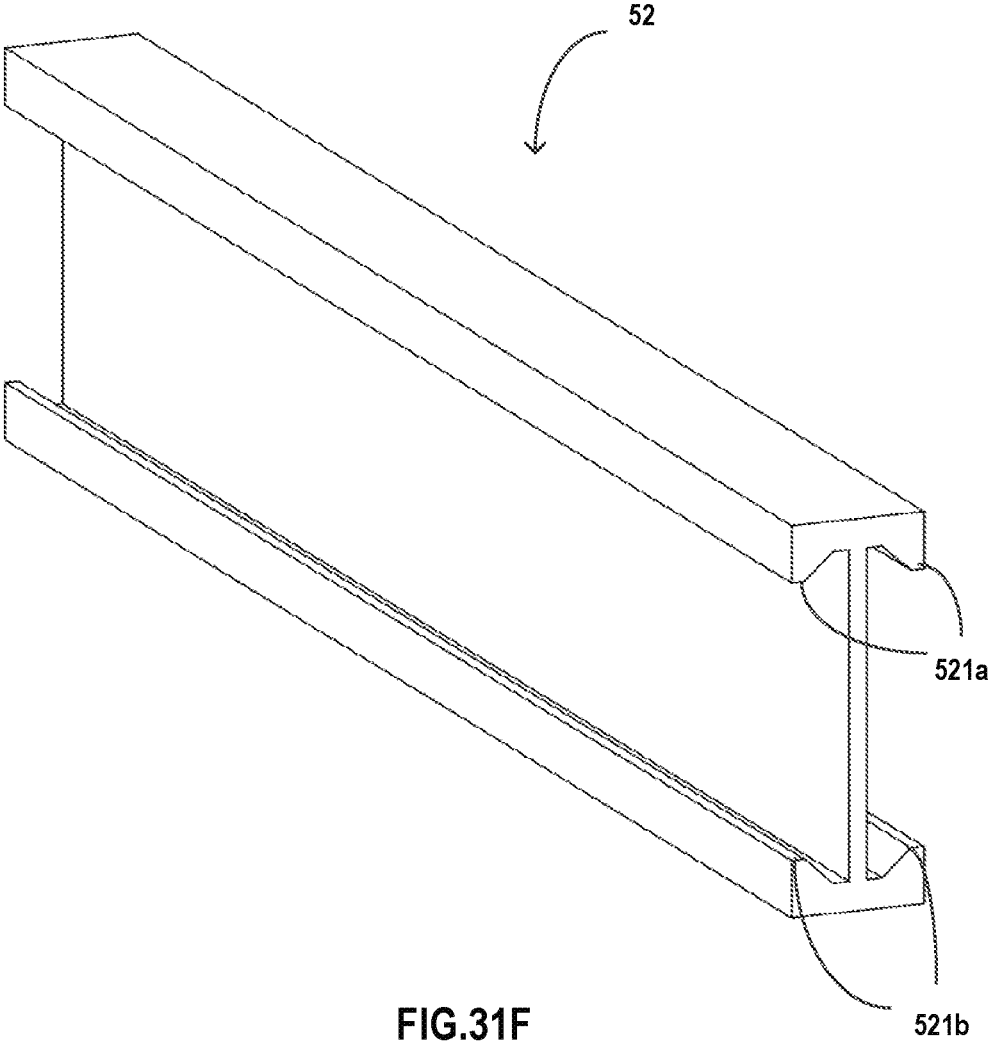

FIG.31F

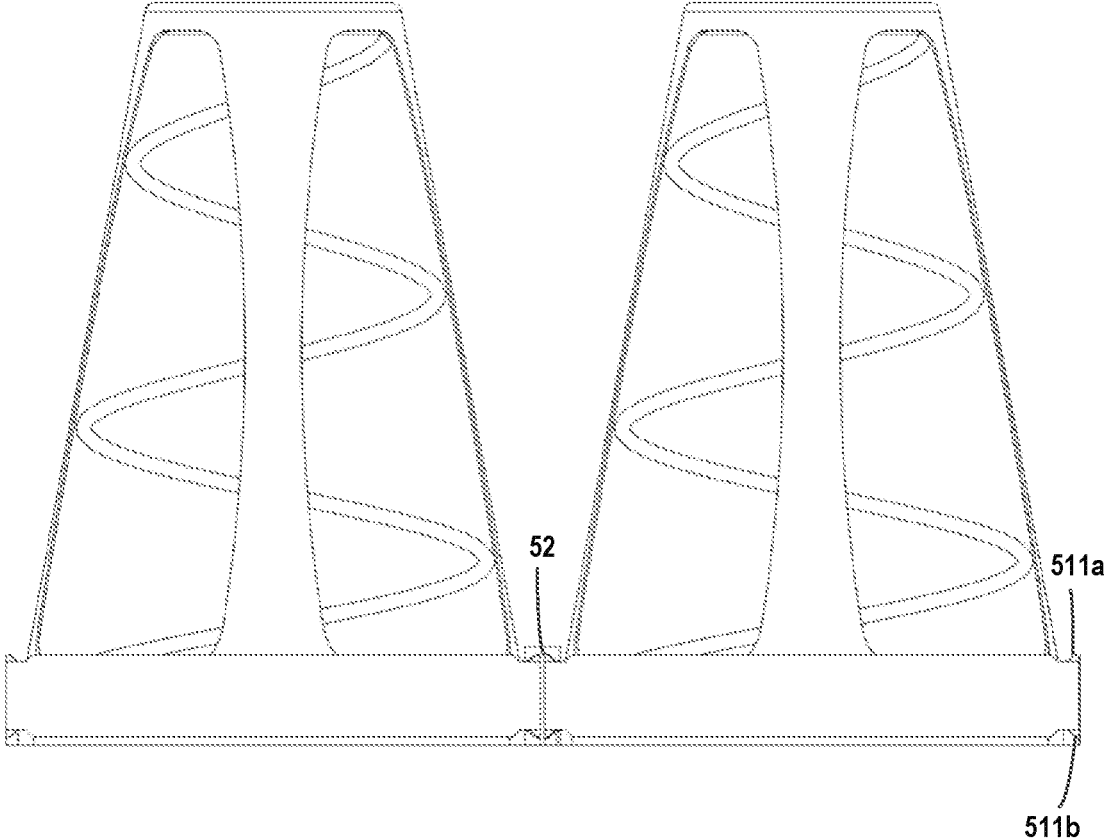

FIG.31G

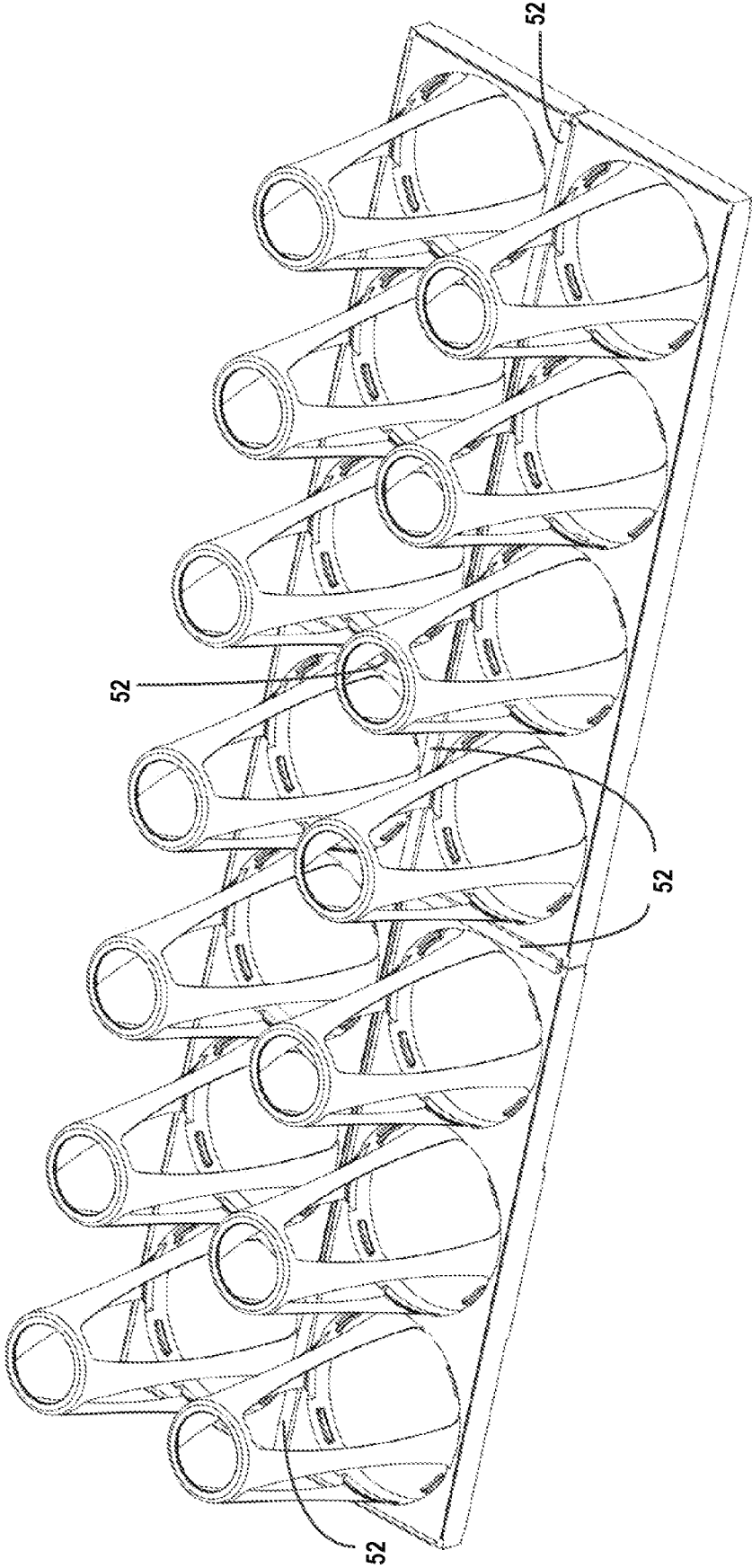

FIG.31H

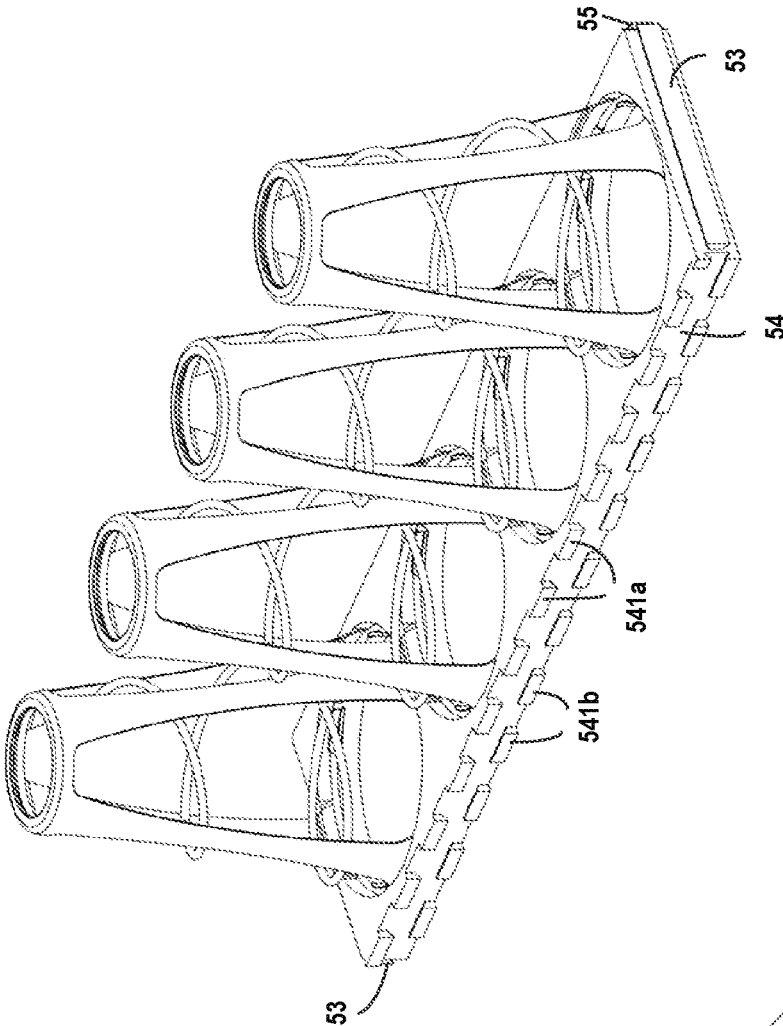

FIG.31I

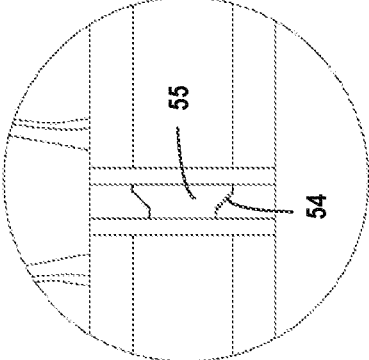

FIG.31K

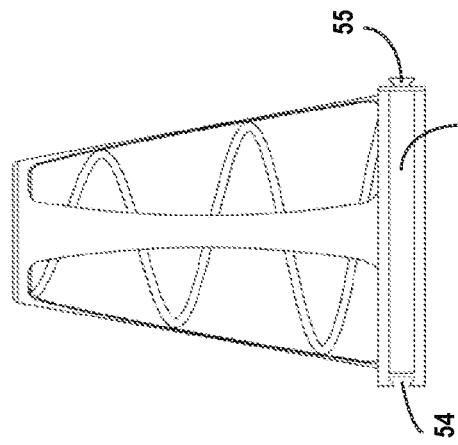

FIG.31J

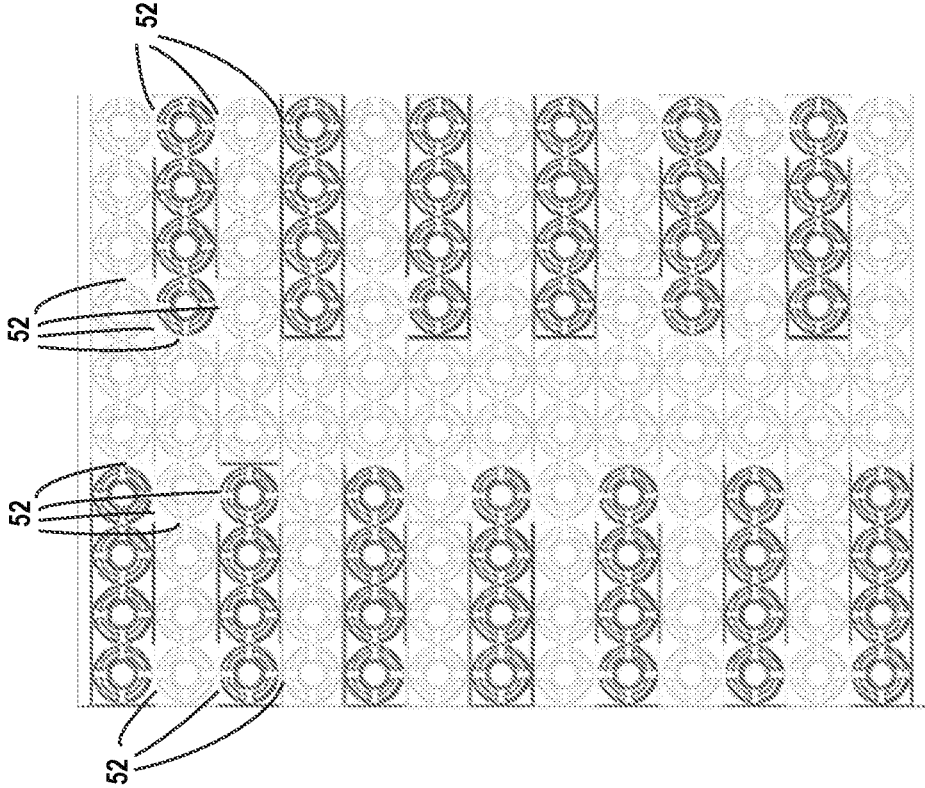

FIG.31M

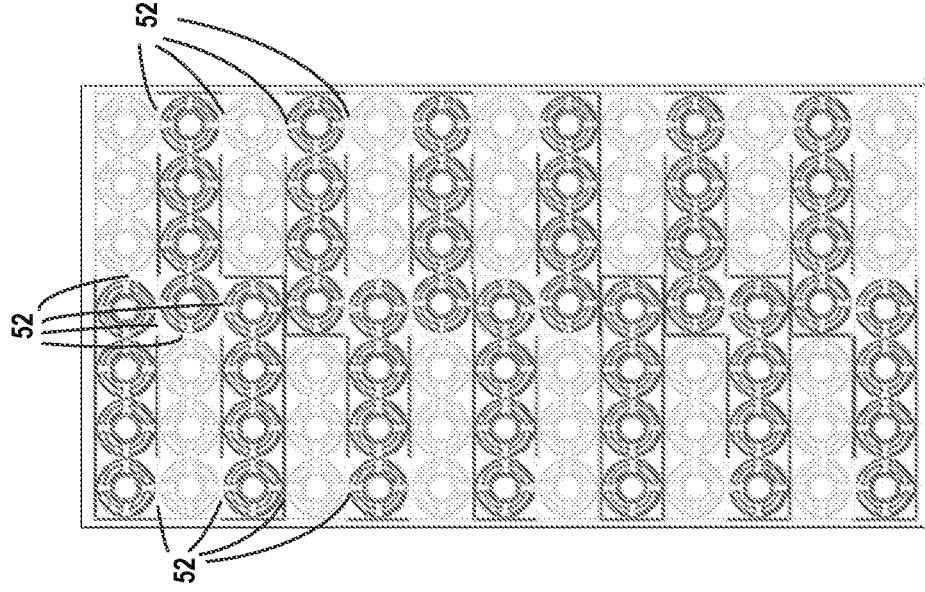

FIG.31L

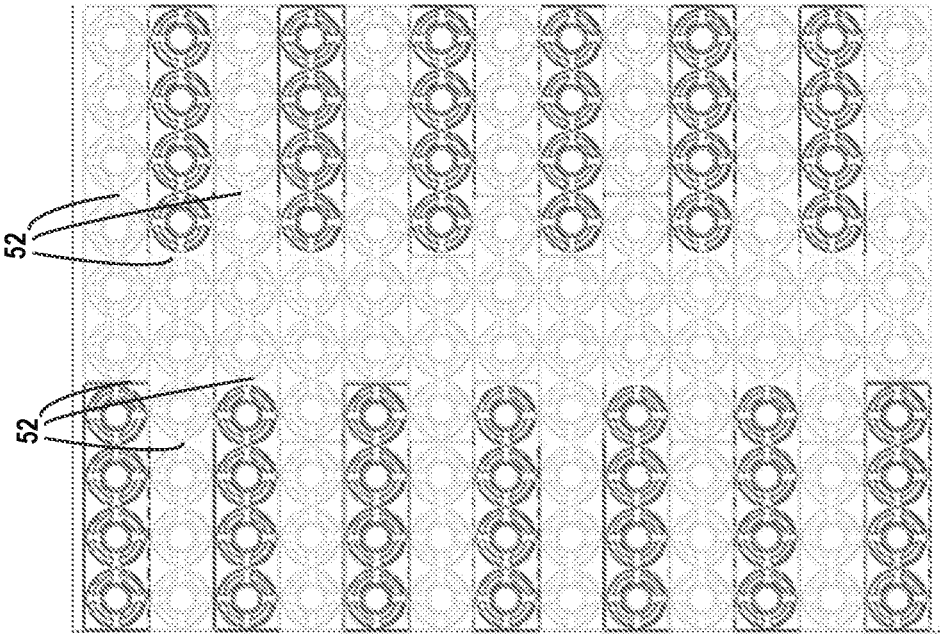

FIG.31P

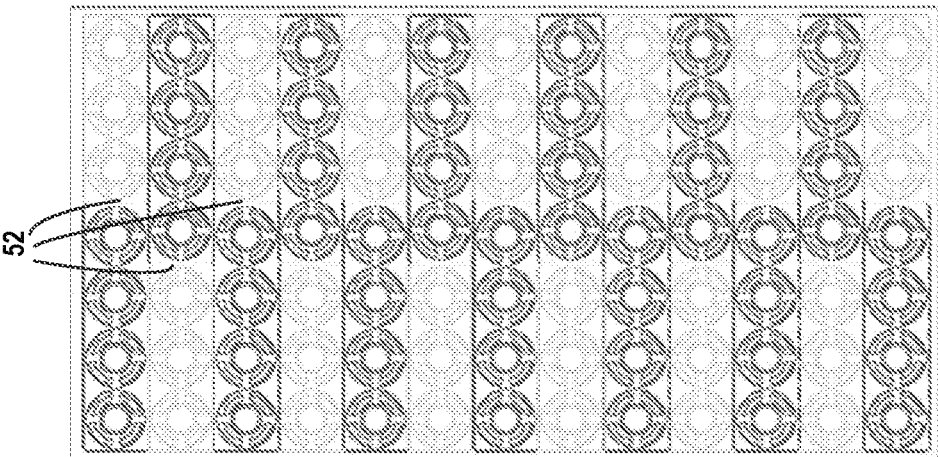

FIG.31N

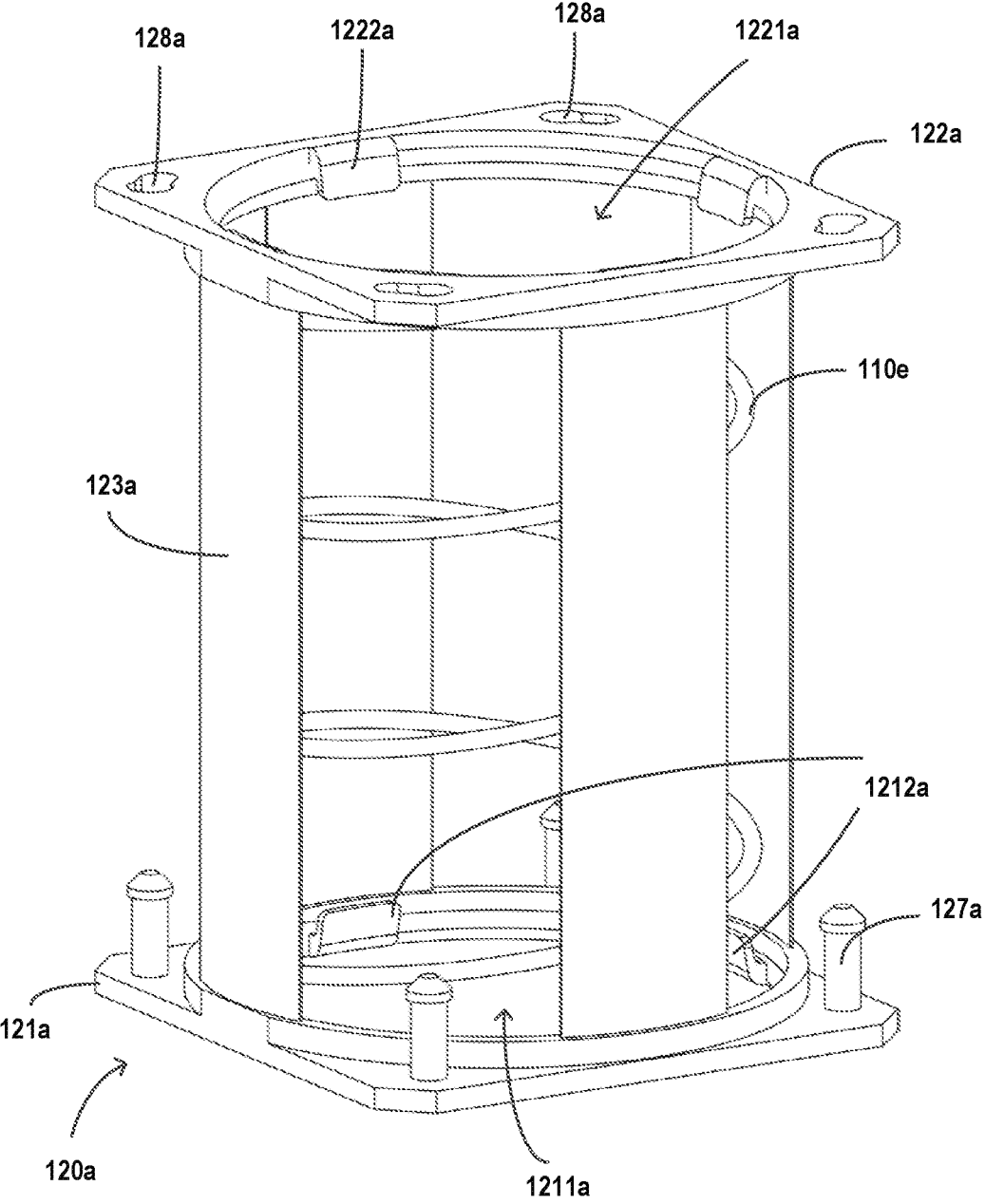

FIG.32A

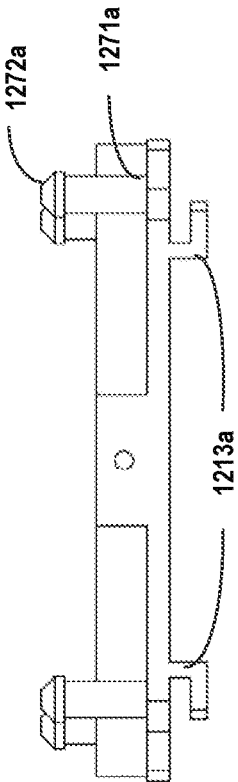

FIG. 32D

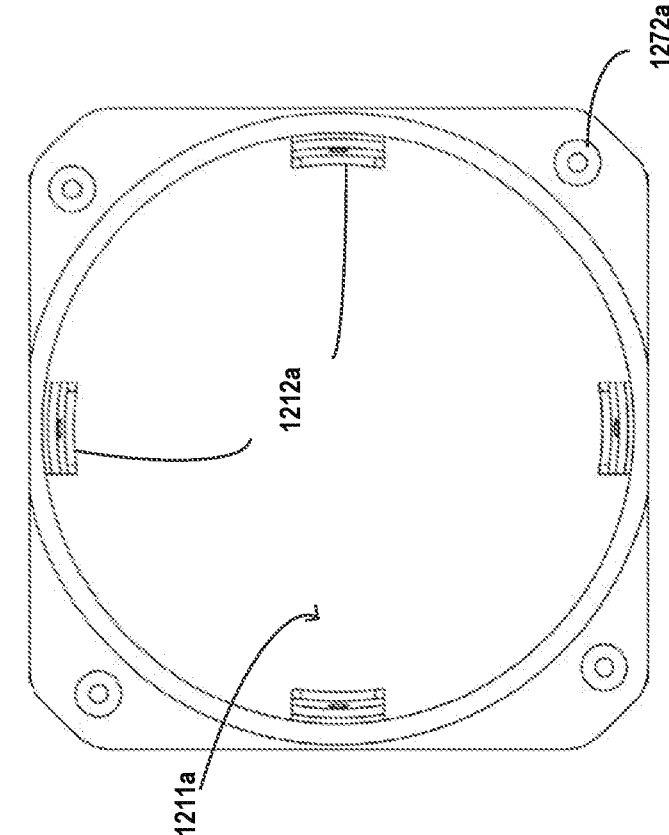

FIG. 32C

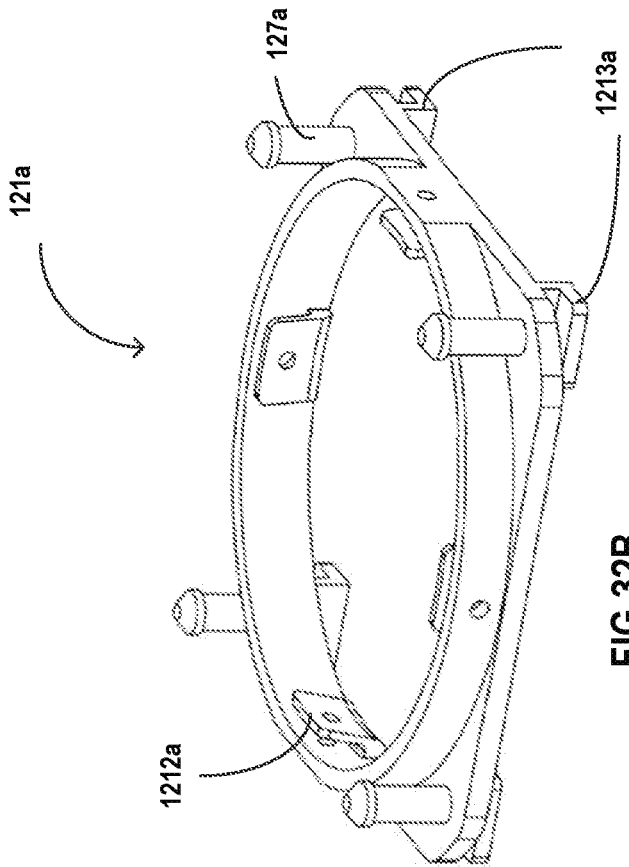

FIG. 32B

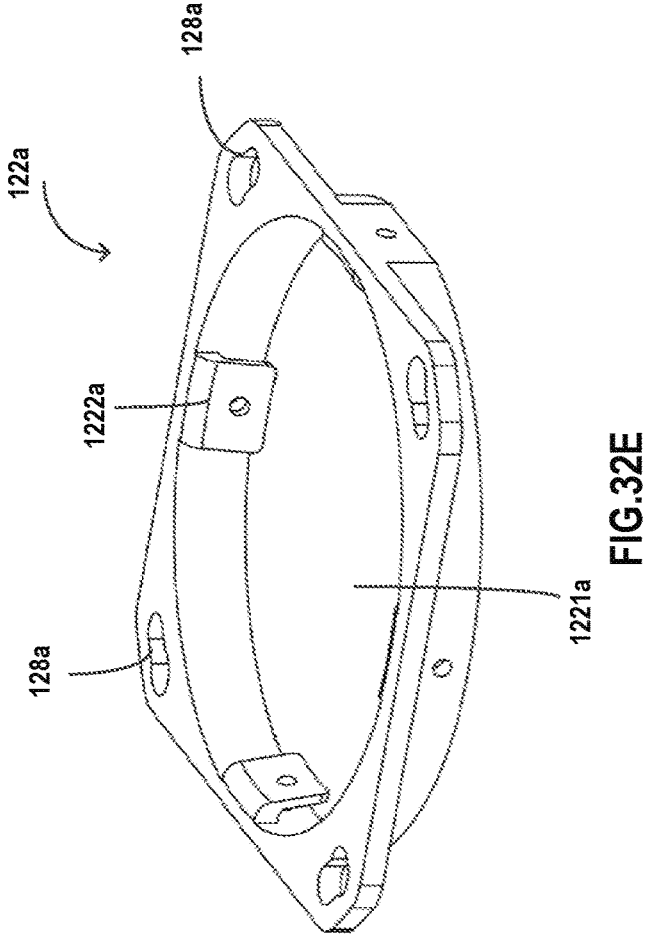

FIG. 32E

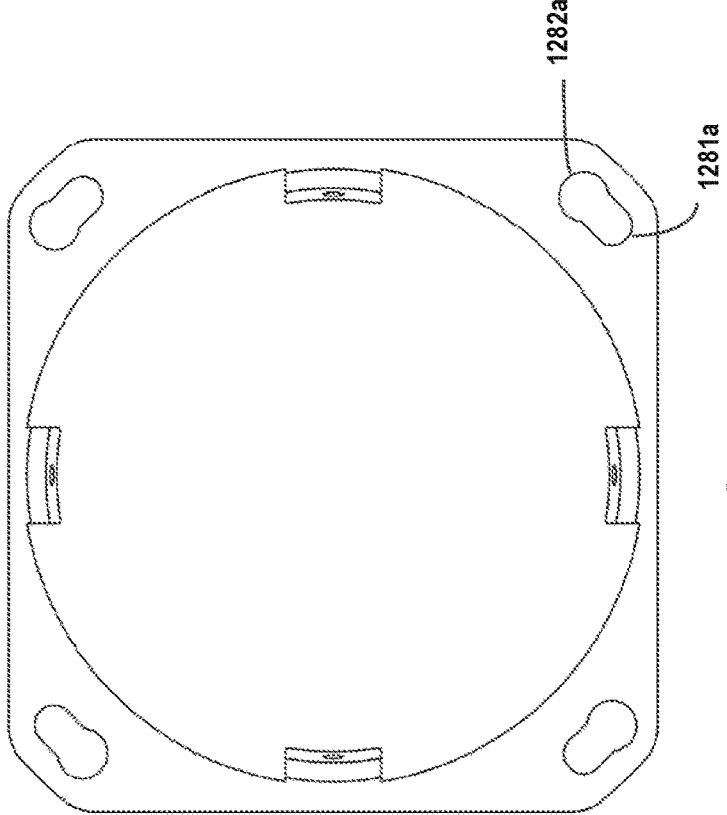

FIG. 32F

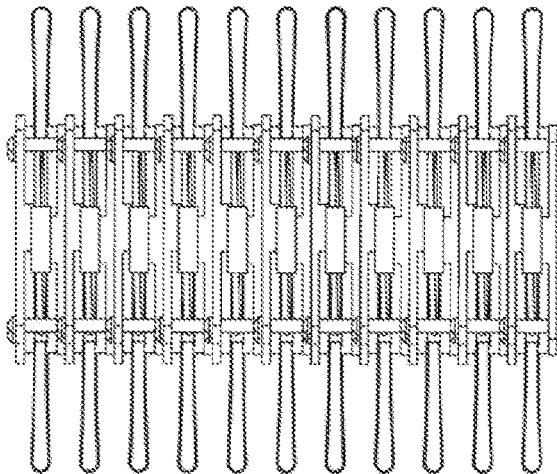

FIG. 32I

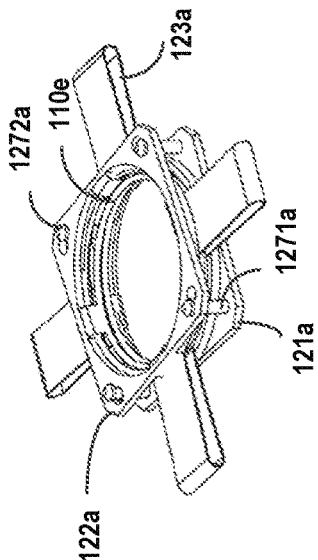

FIG. 32G

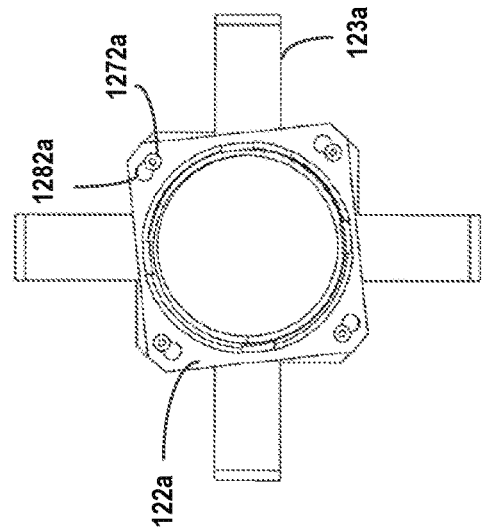

FIG. 32H

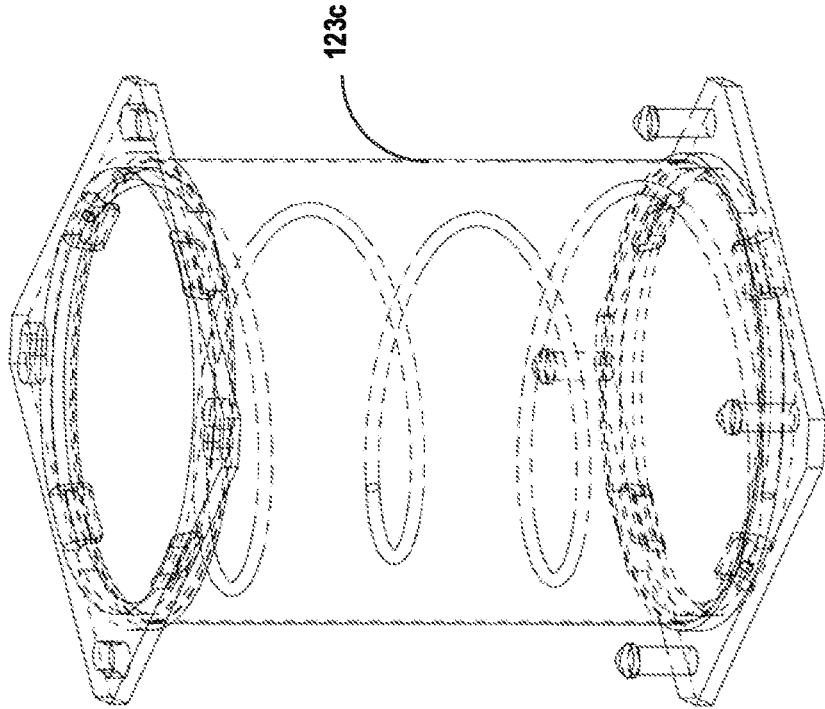

FIG.32K

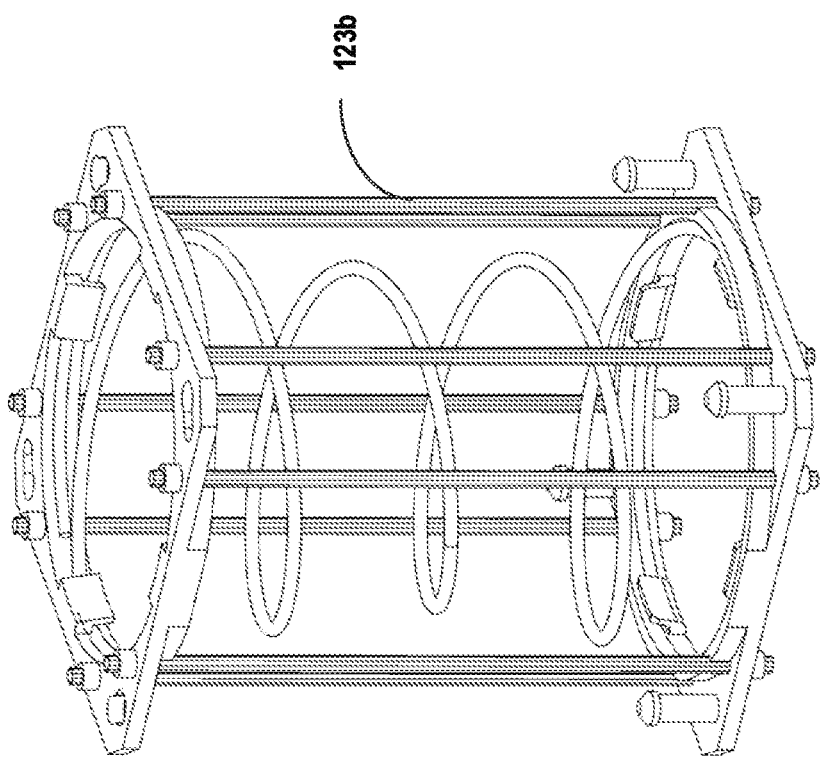

FIG.32J

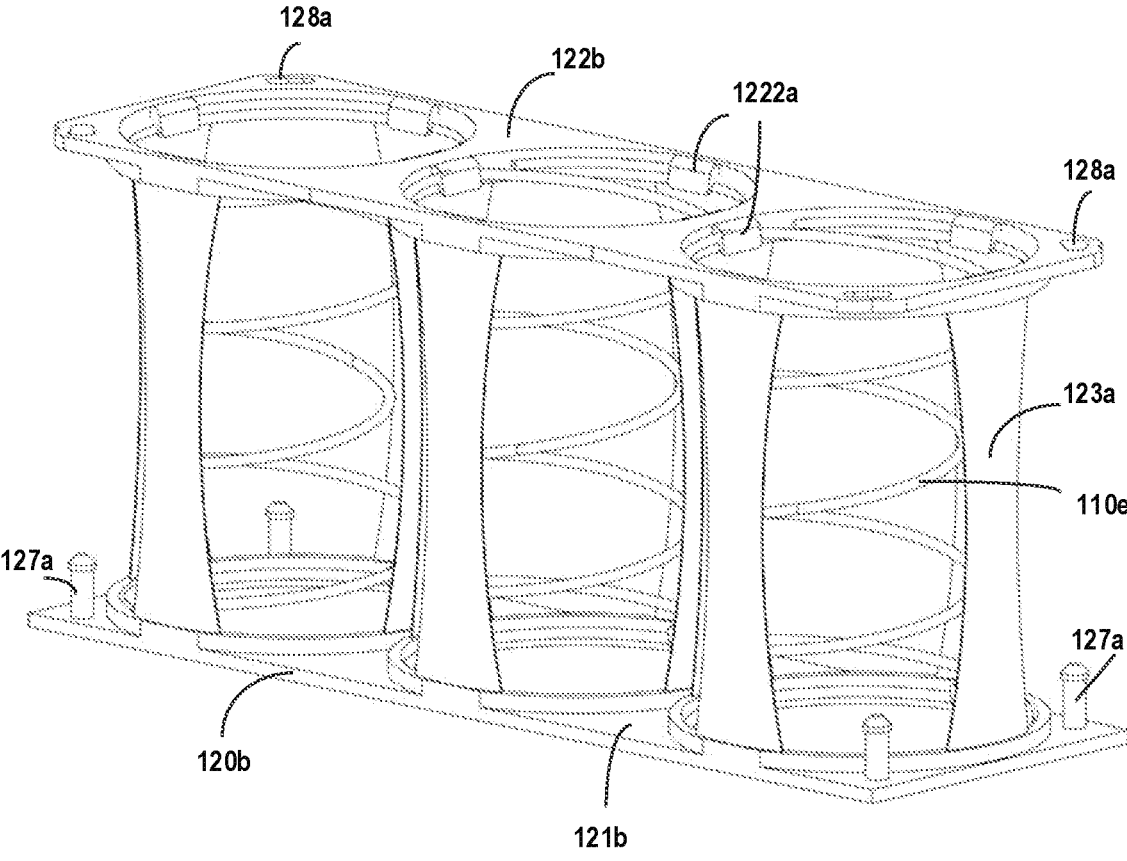

FIG.32L

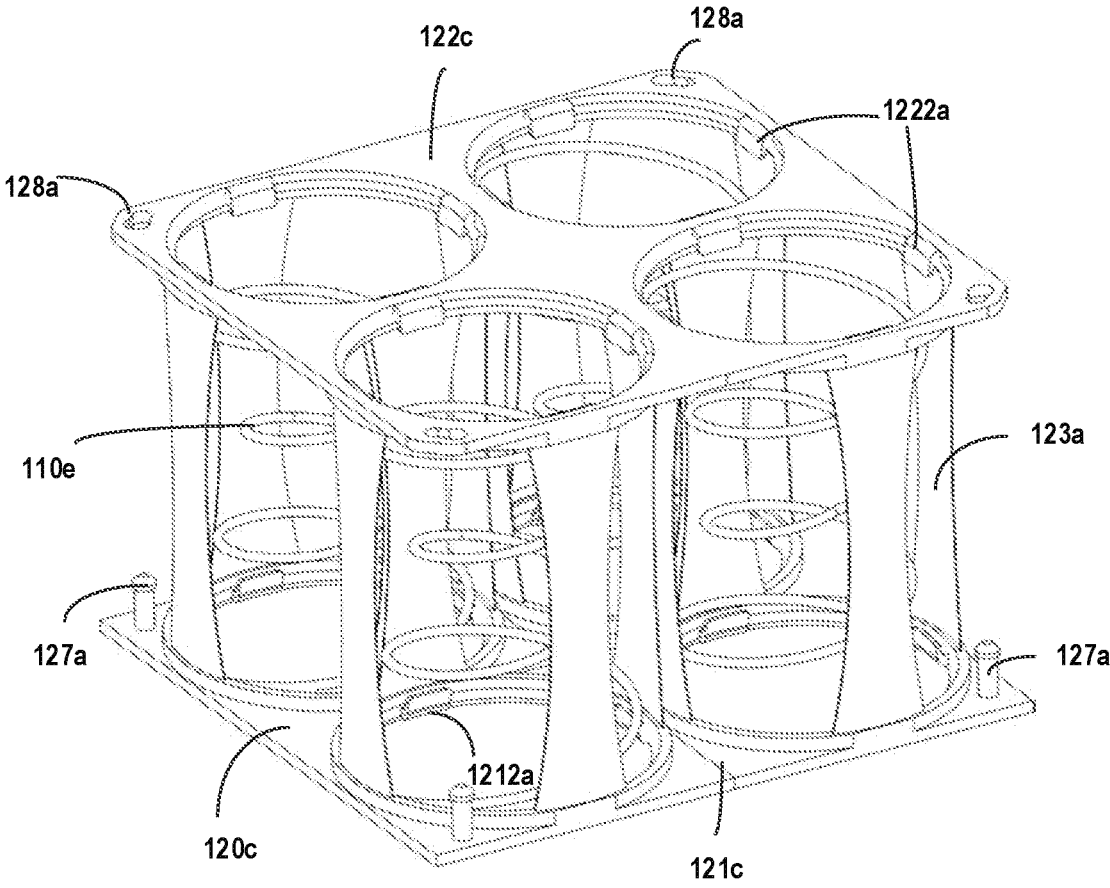

FIG.32M

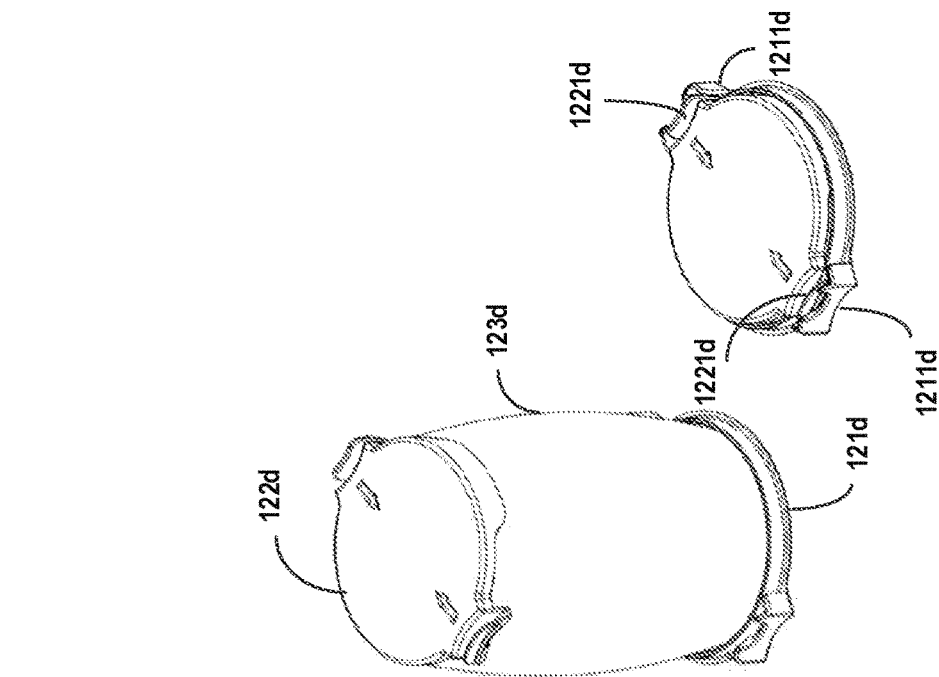

FIG.33A

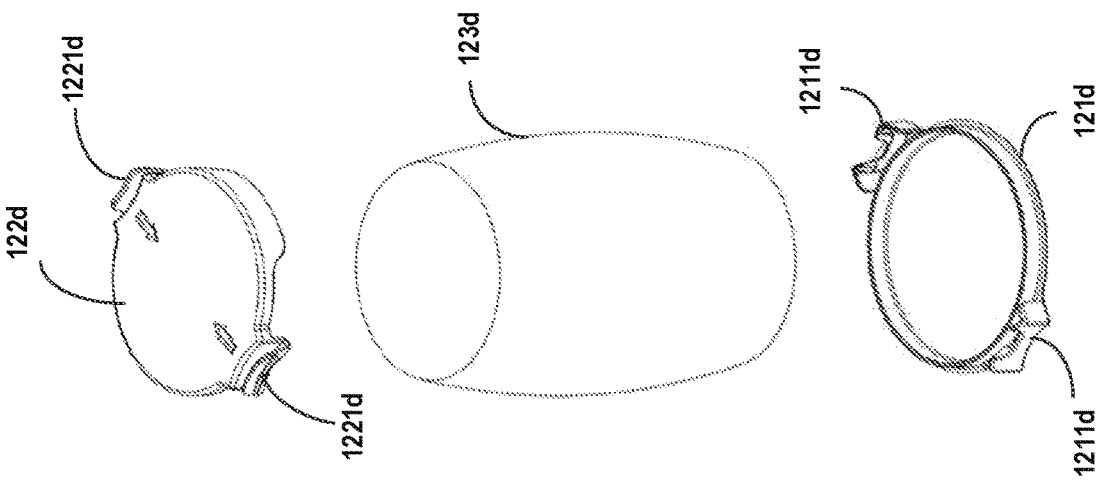

FIG.33B

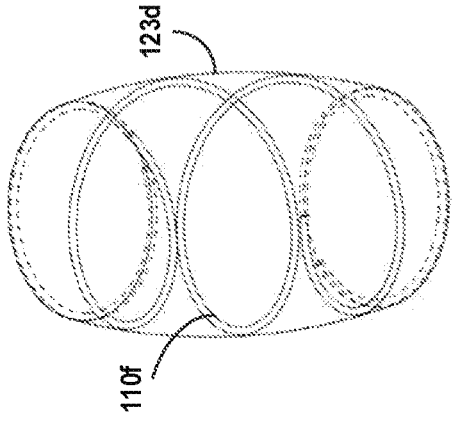

FIG.33C

FIG.33D

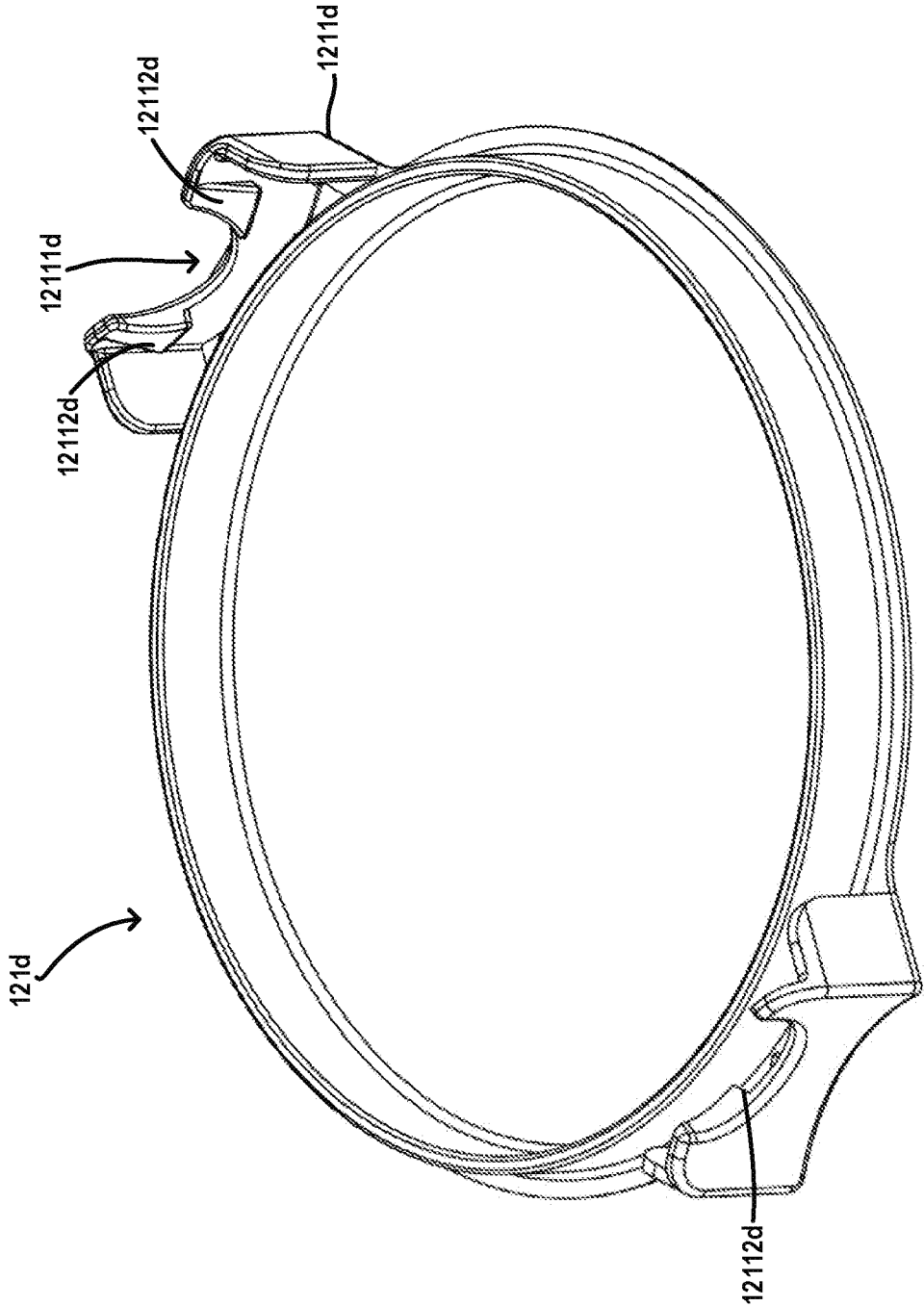

FIG.33E

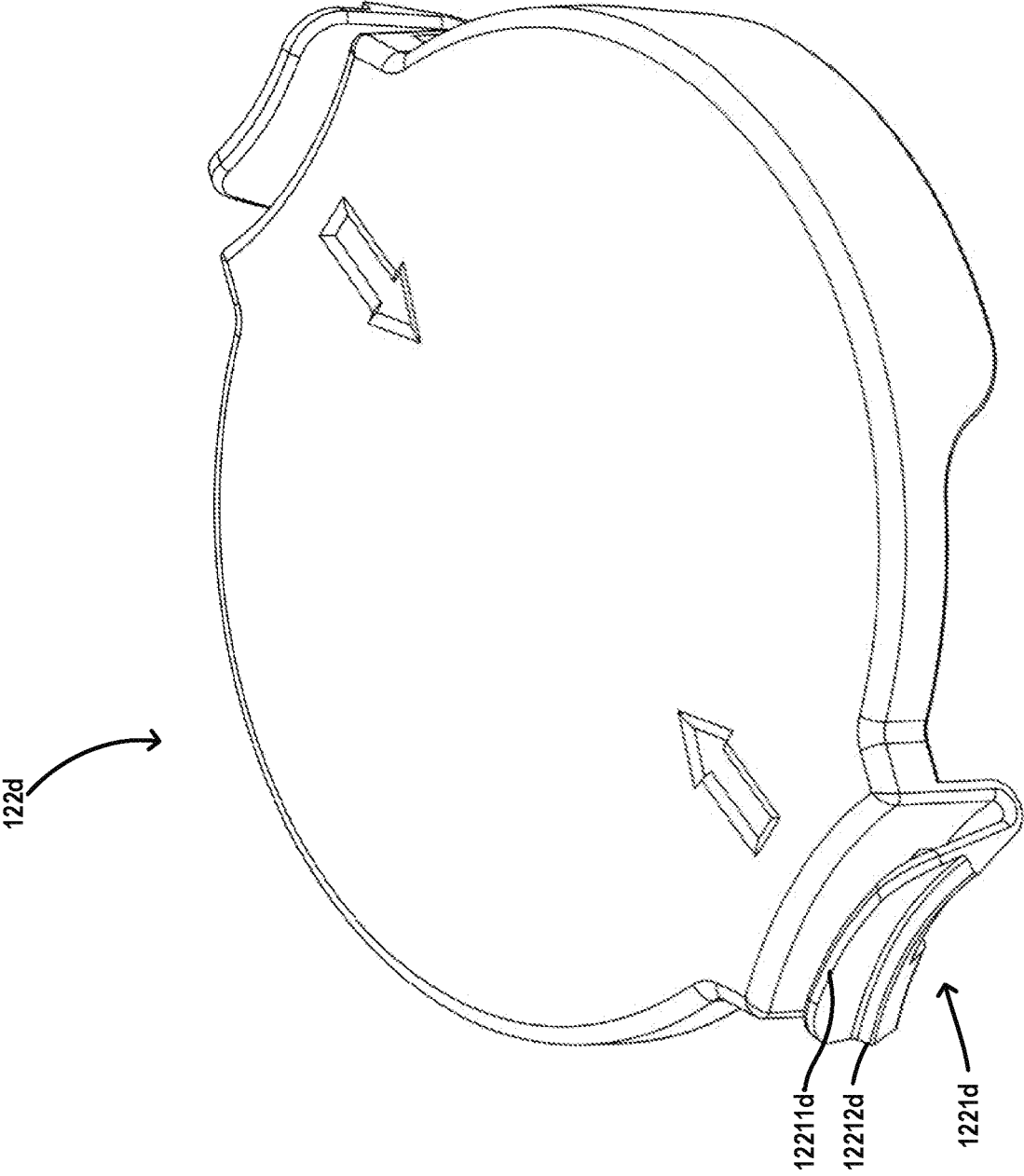

FIG.33F

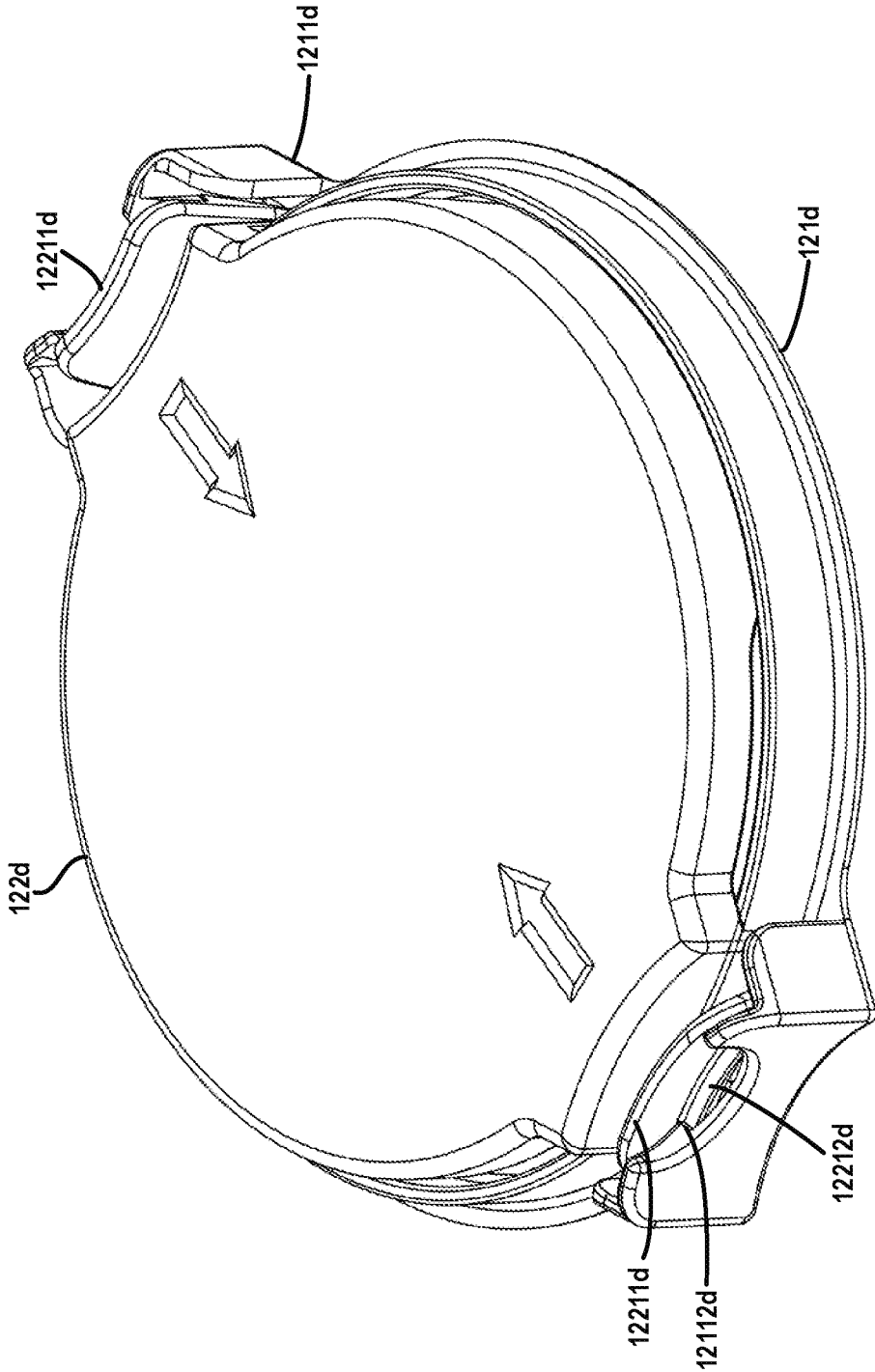

FIG.33G

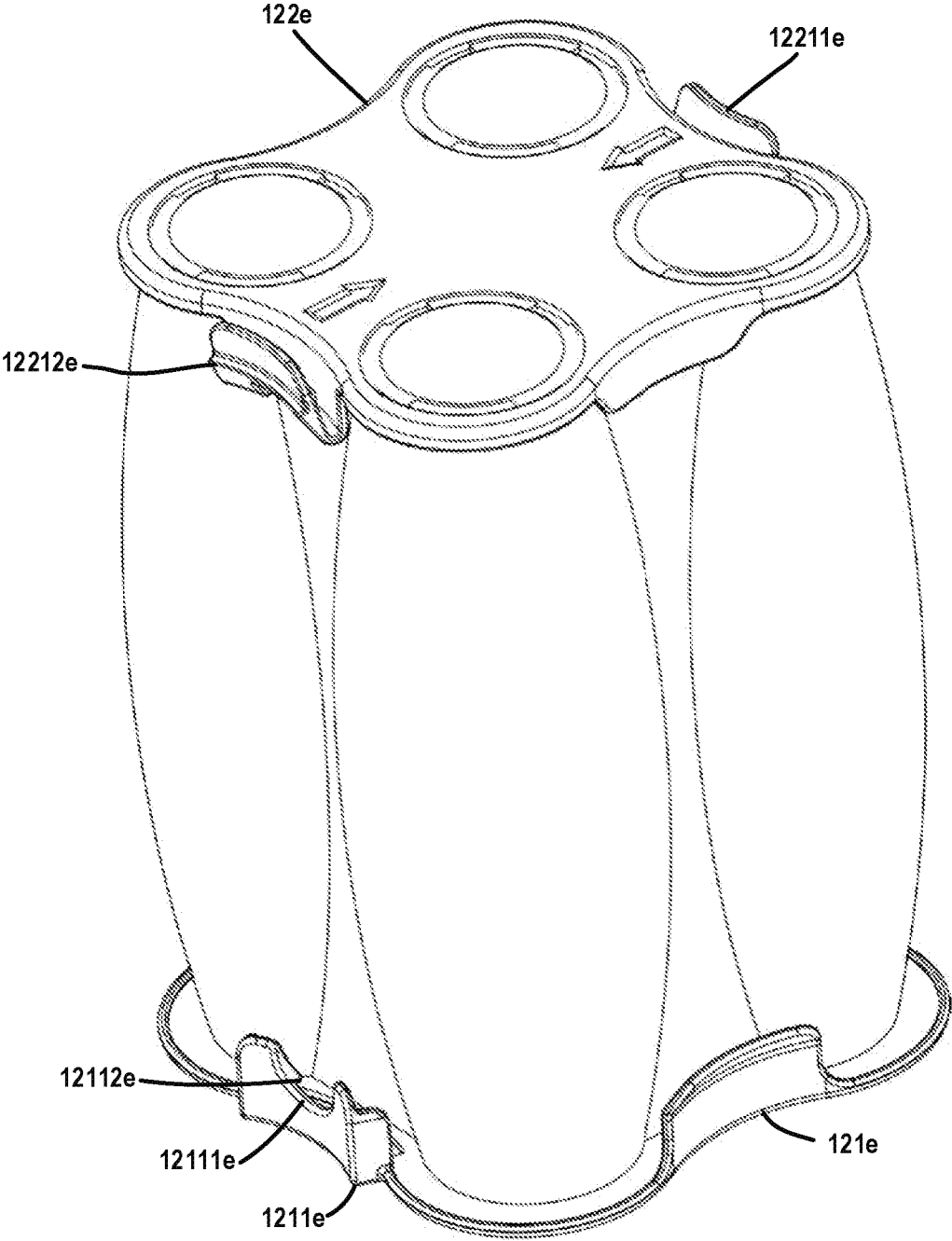

FIG.33H

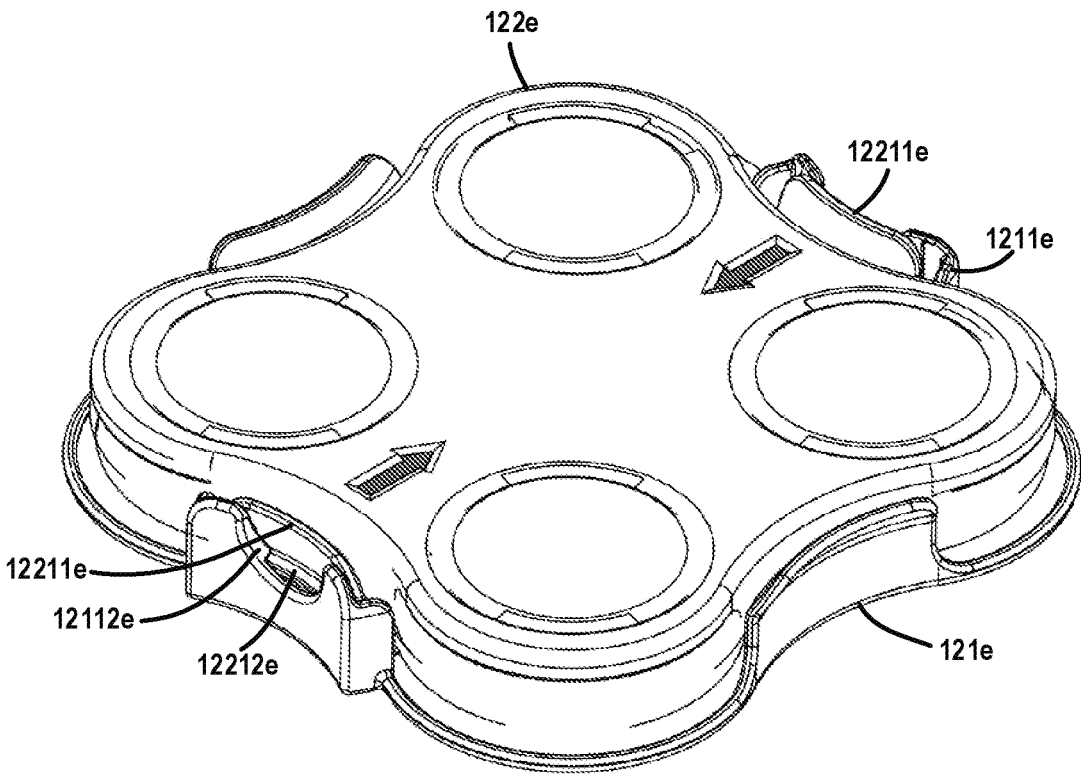

FIG.33I

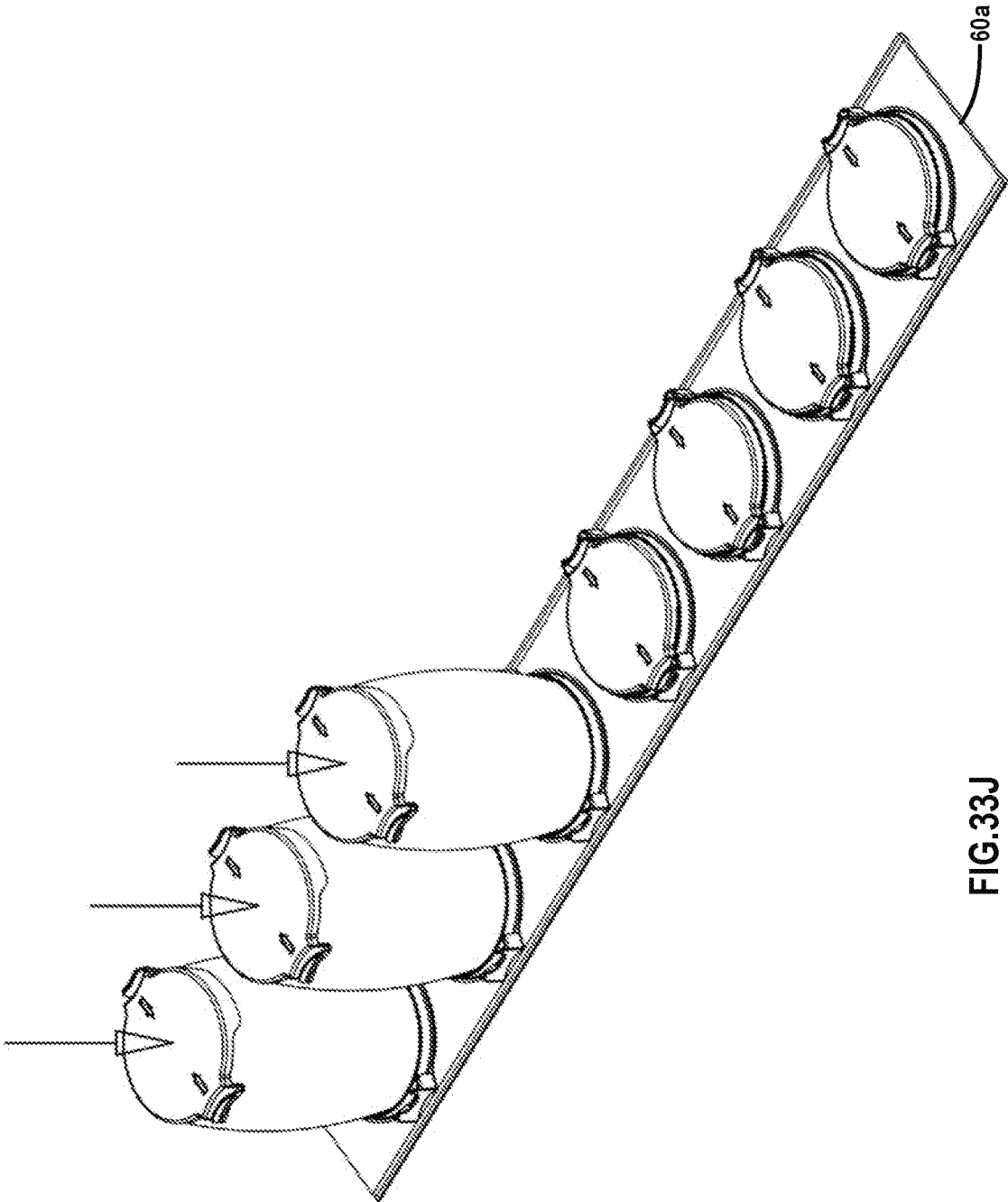

FIG.33J

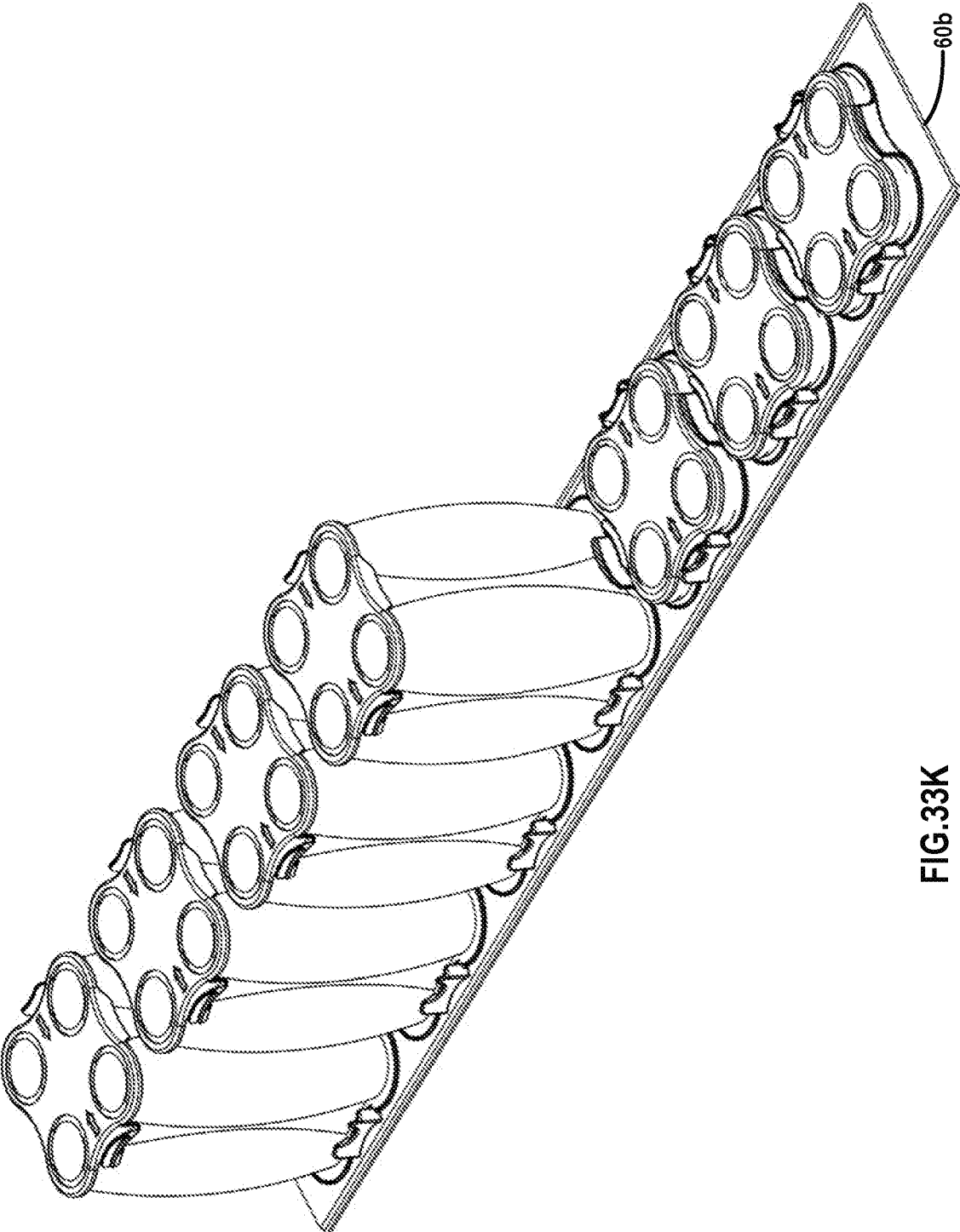

FIG.33K

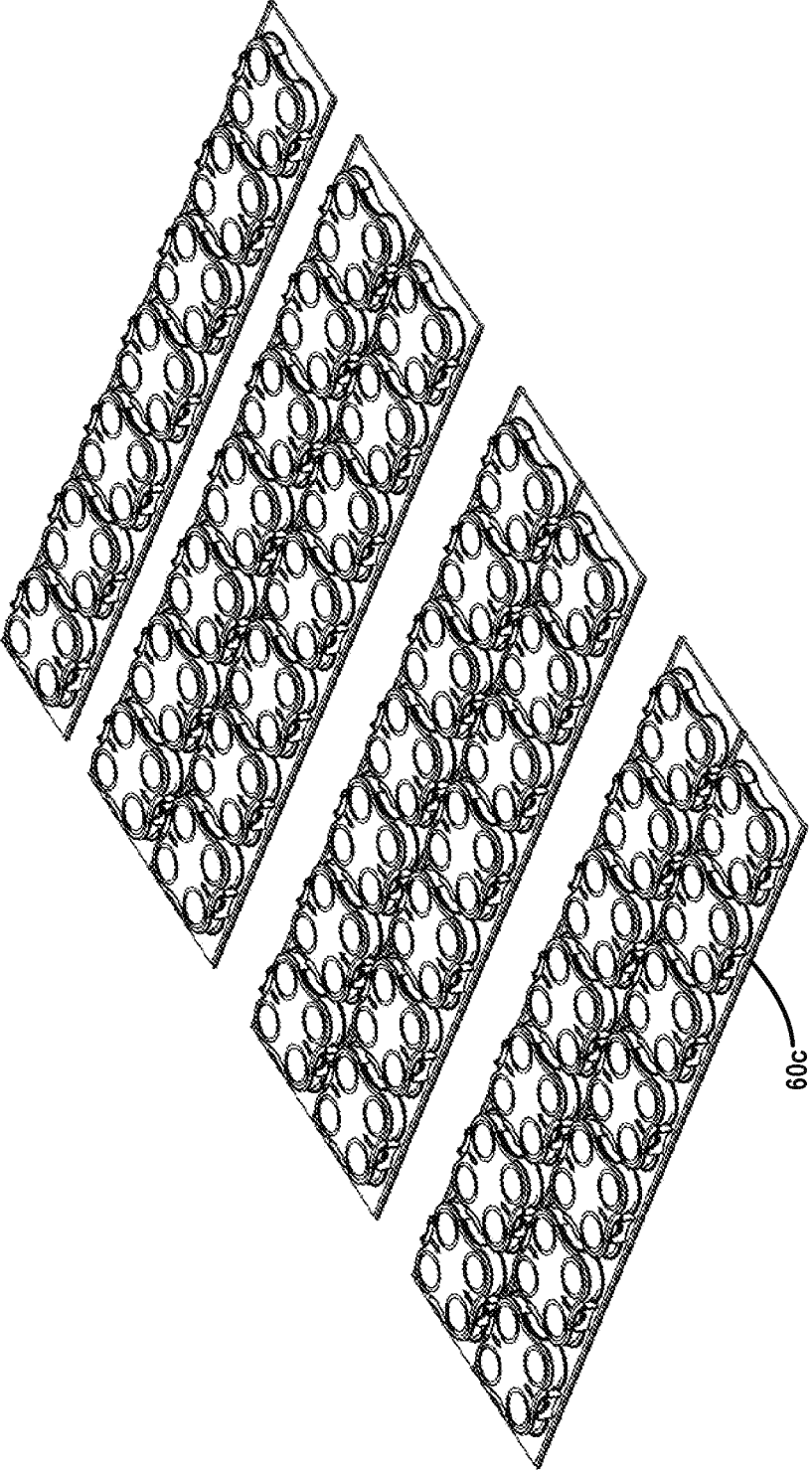

FIG.33L

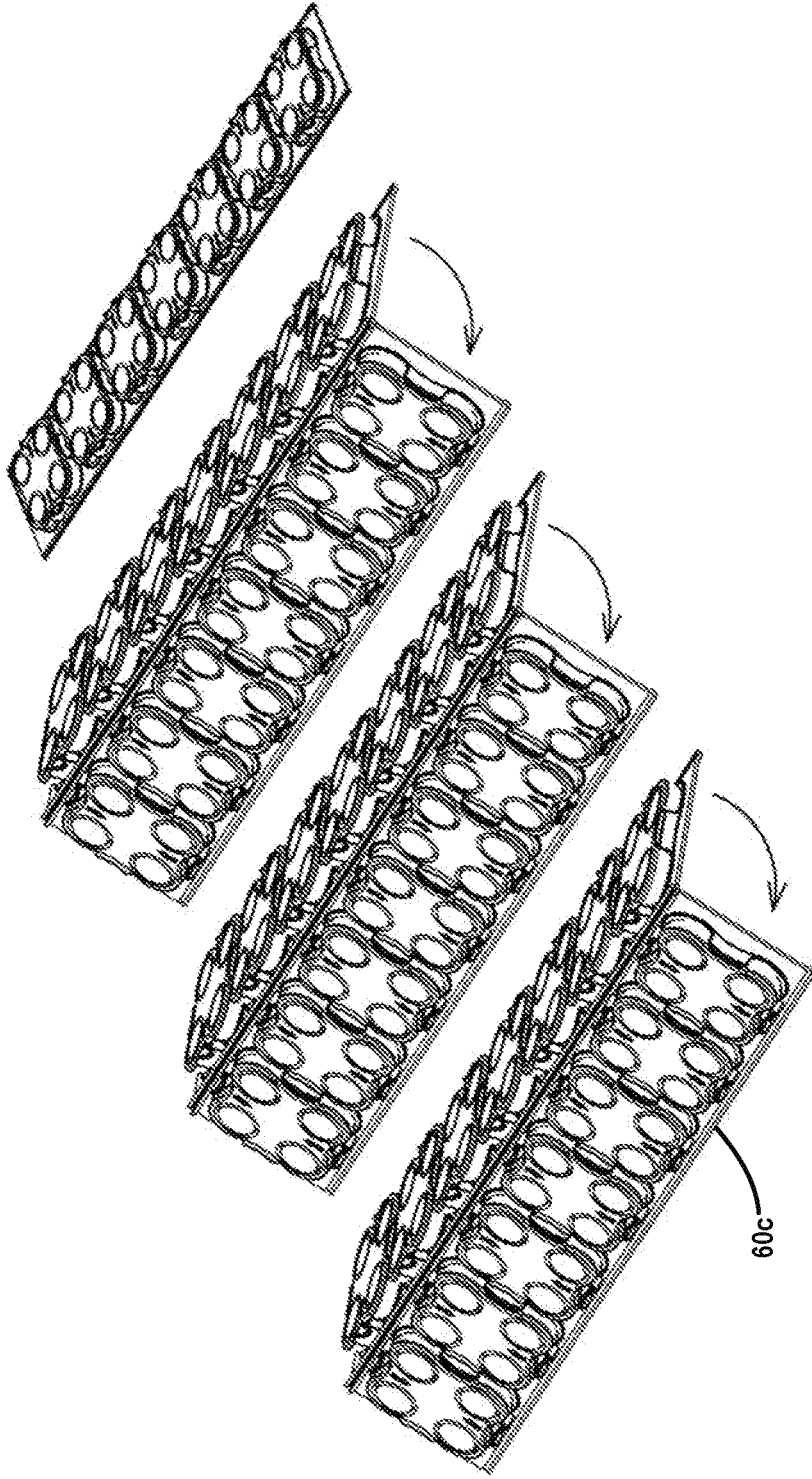

FIG.33M

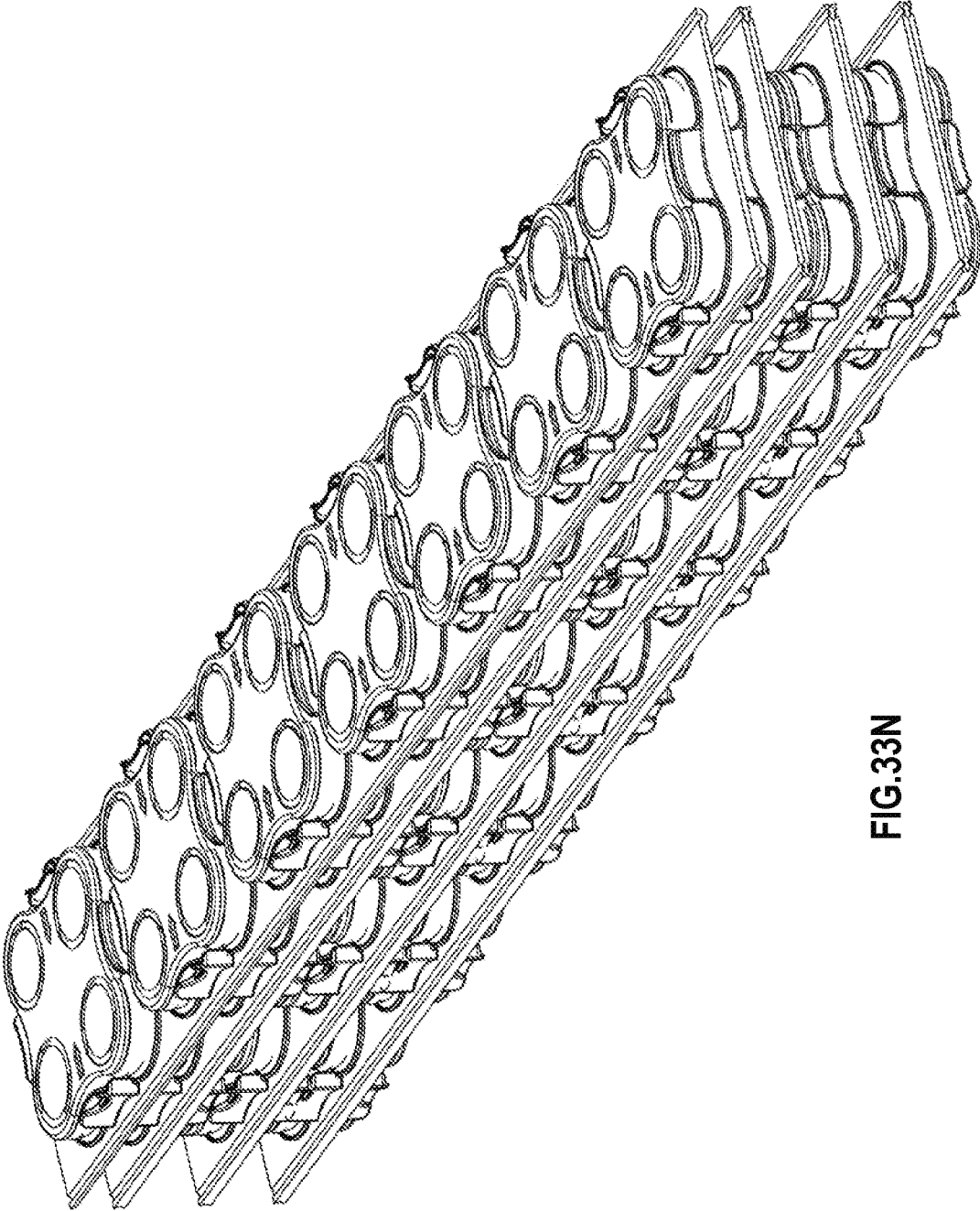

FIG. 33N

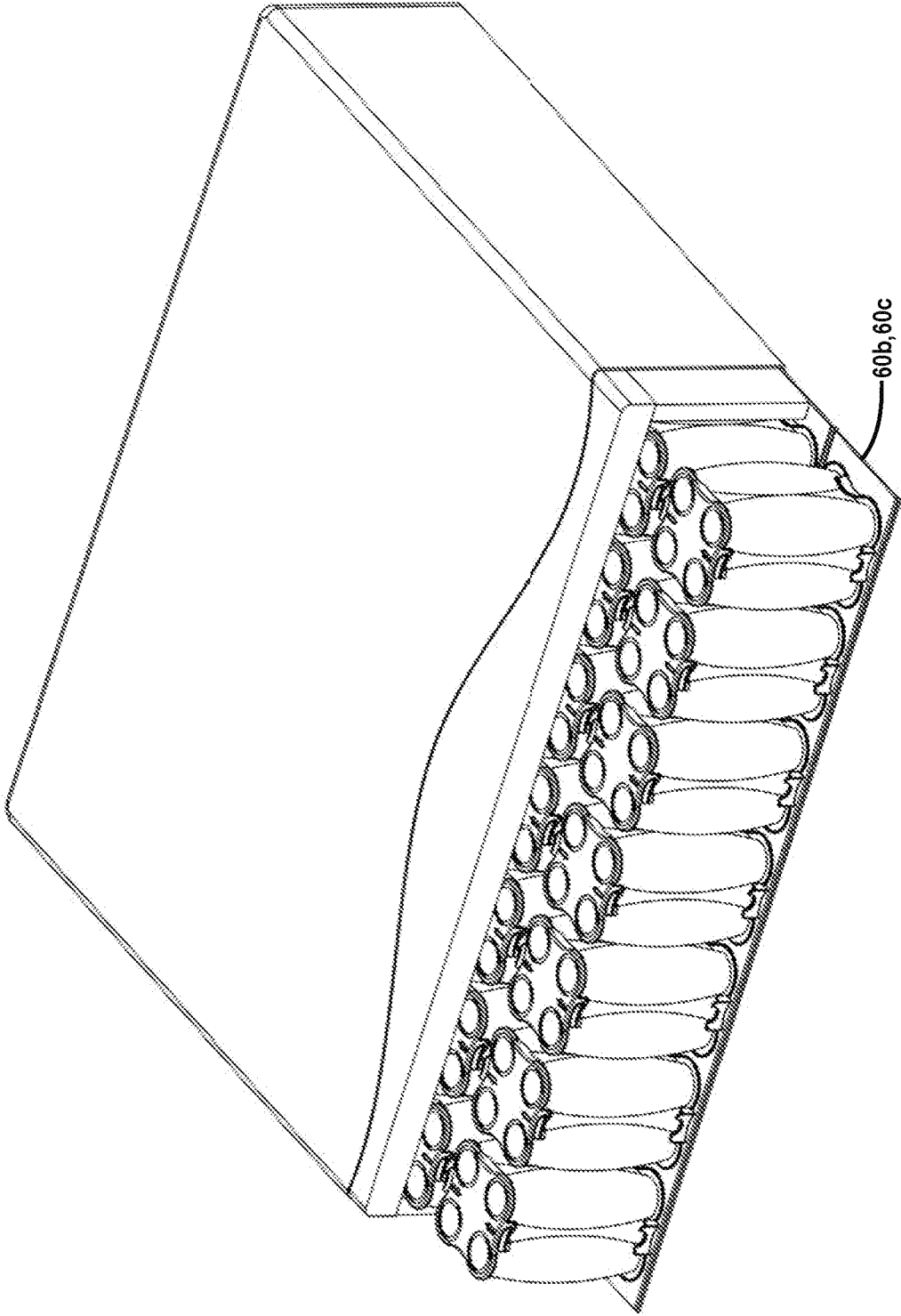

FIG.33P

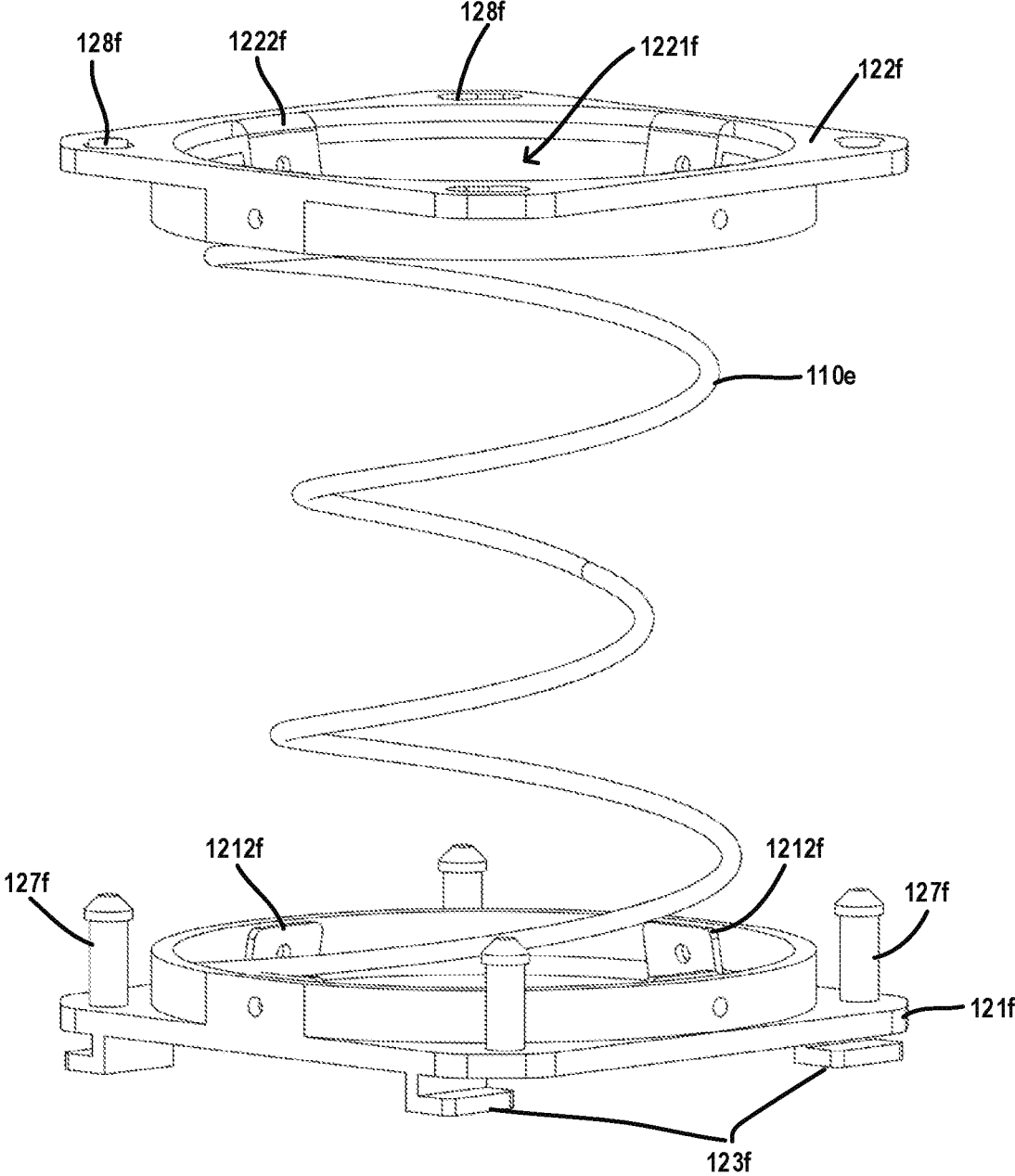

FIG.34A

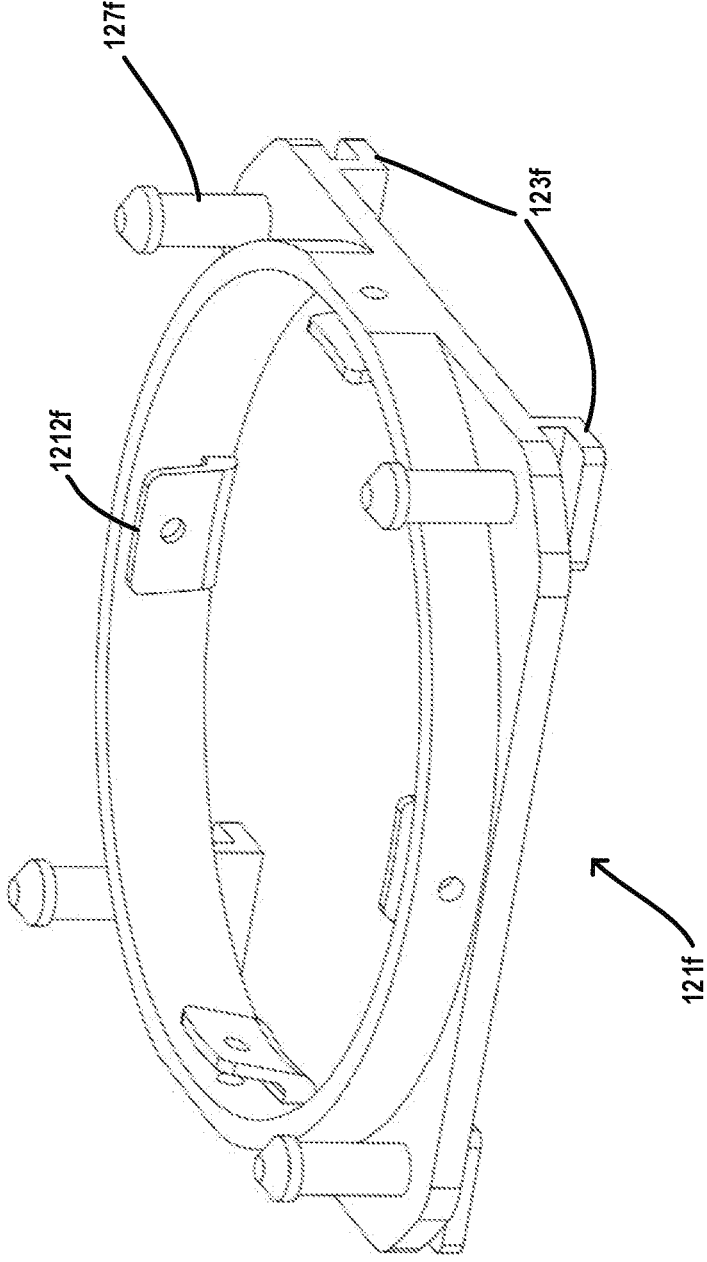

FIG.34B

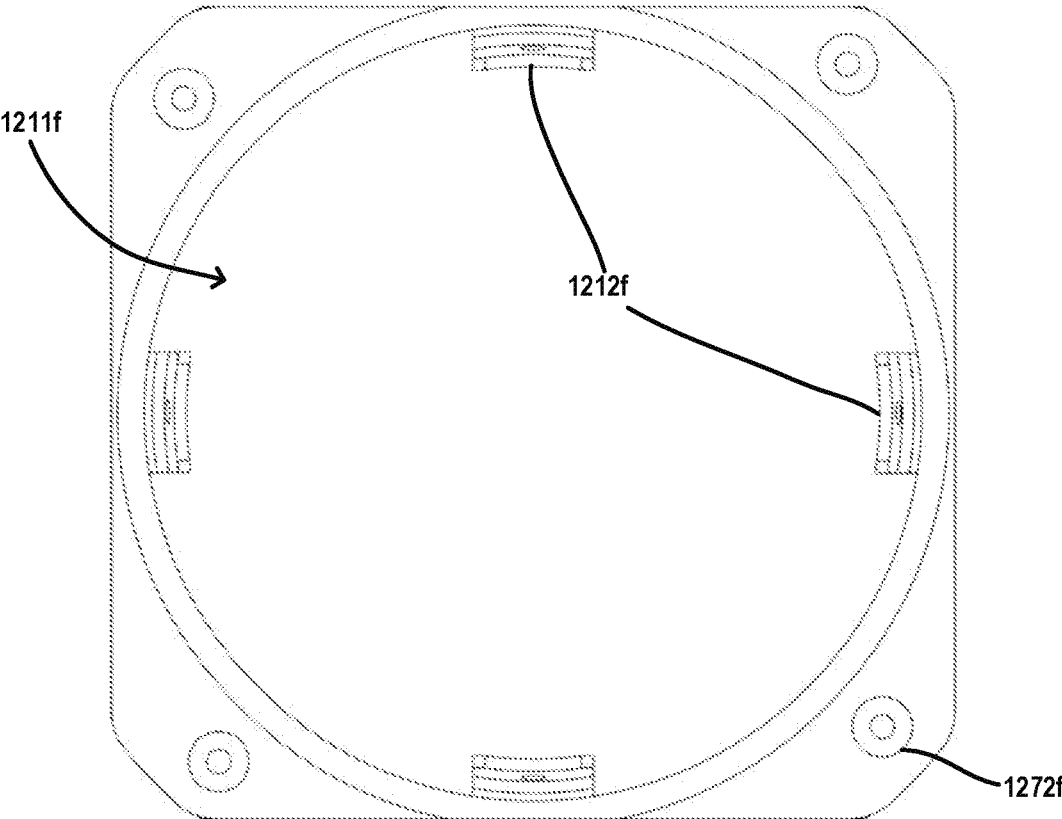

FIG. 34C

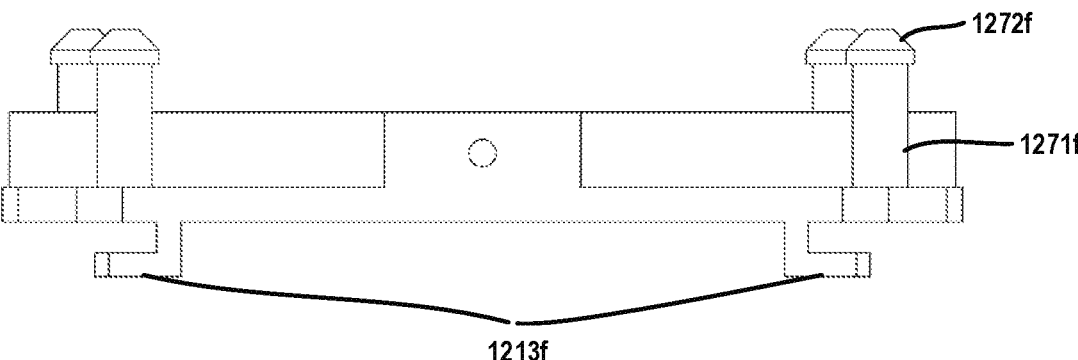

FIG. 34D

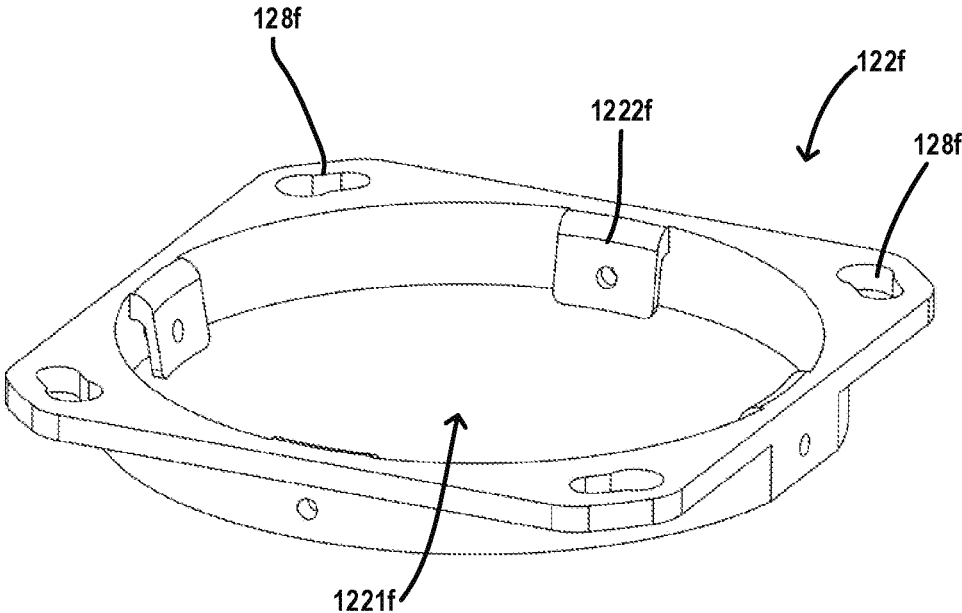

FIG. 34E

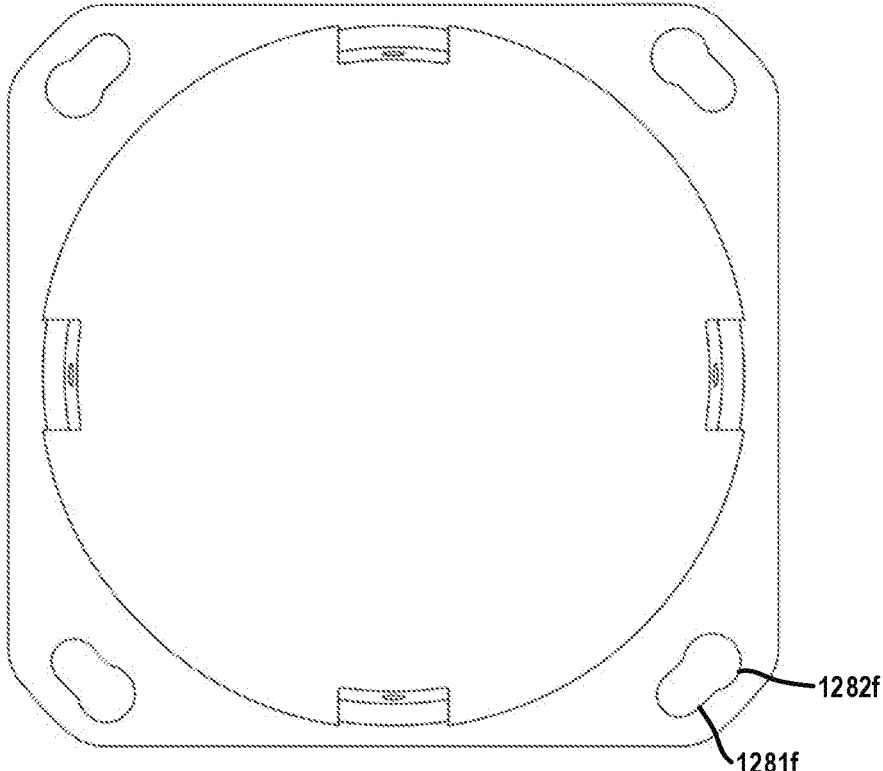

FIG. 34F

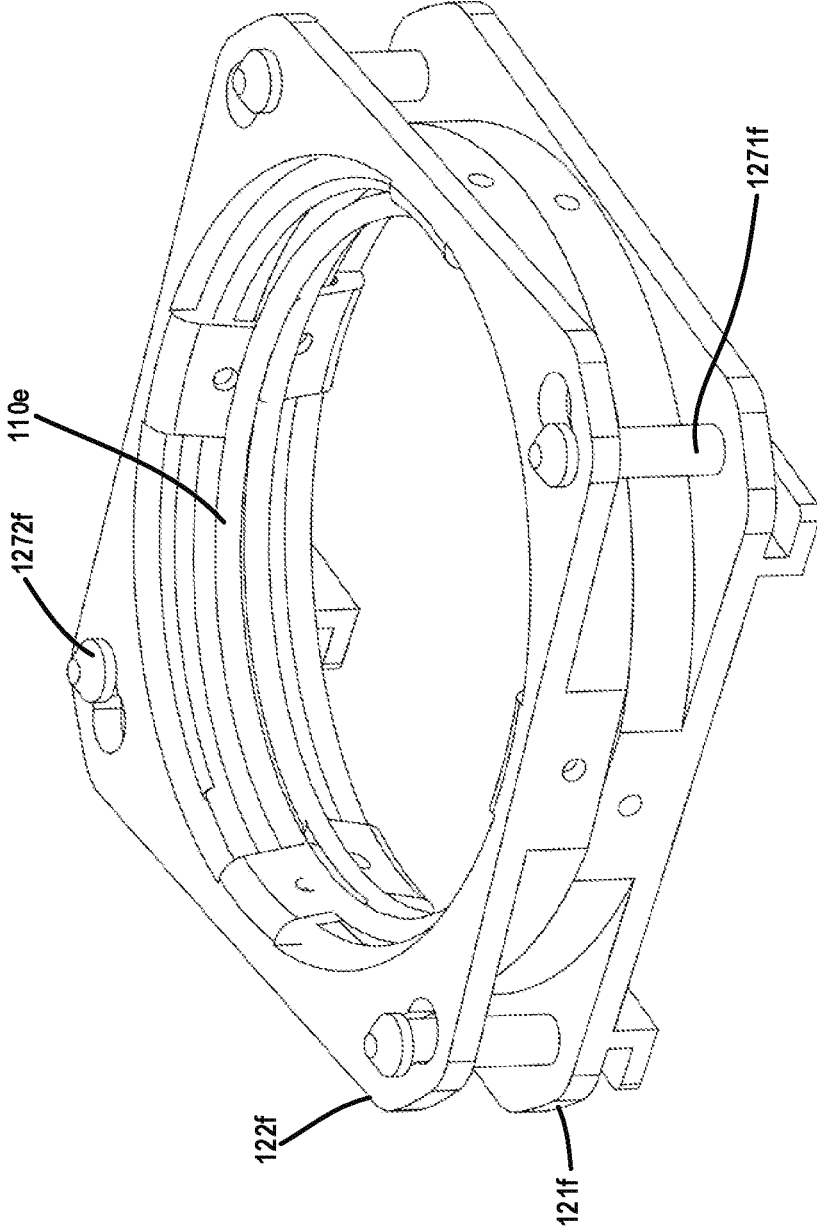

FIG.34G

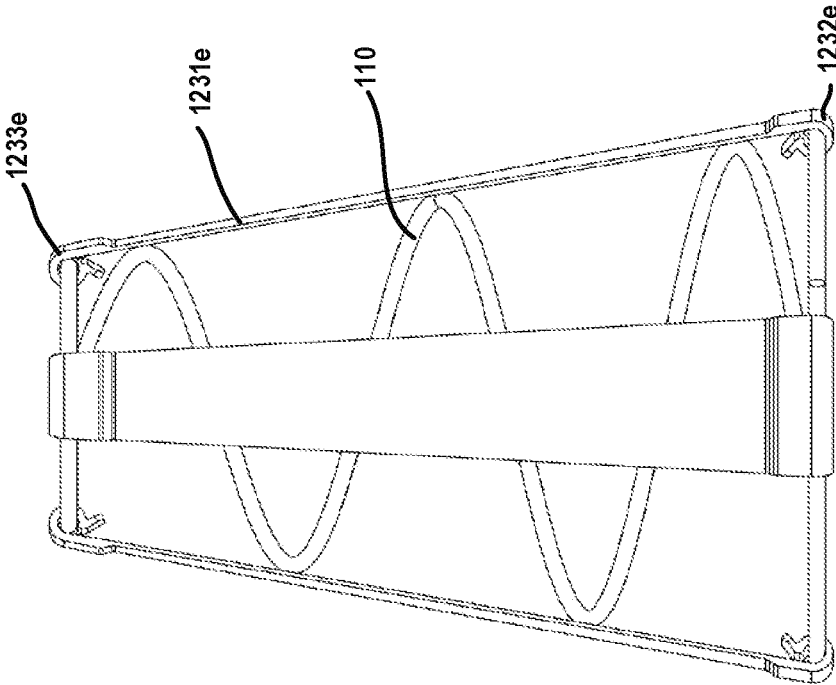

FIG. 35B

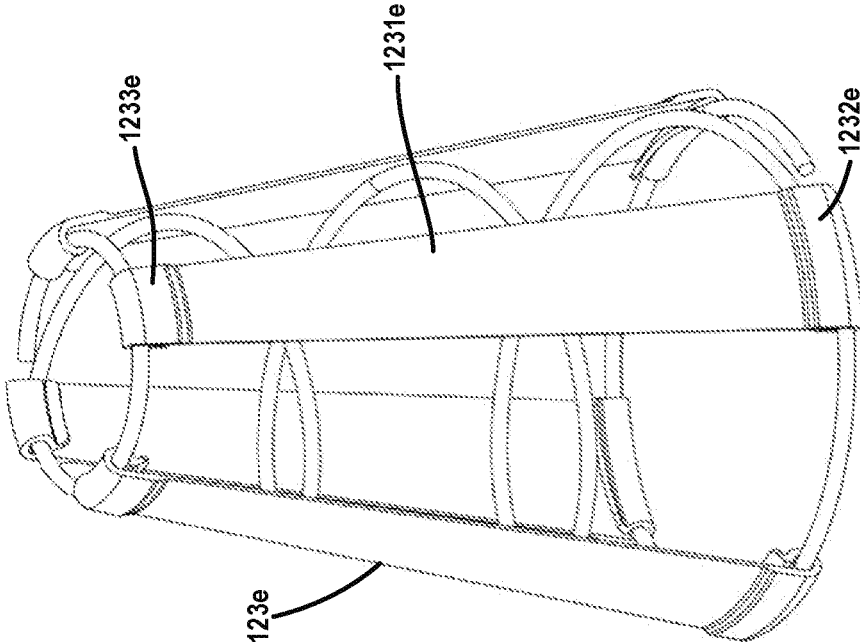

FIG. 35A

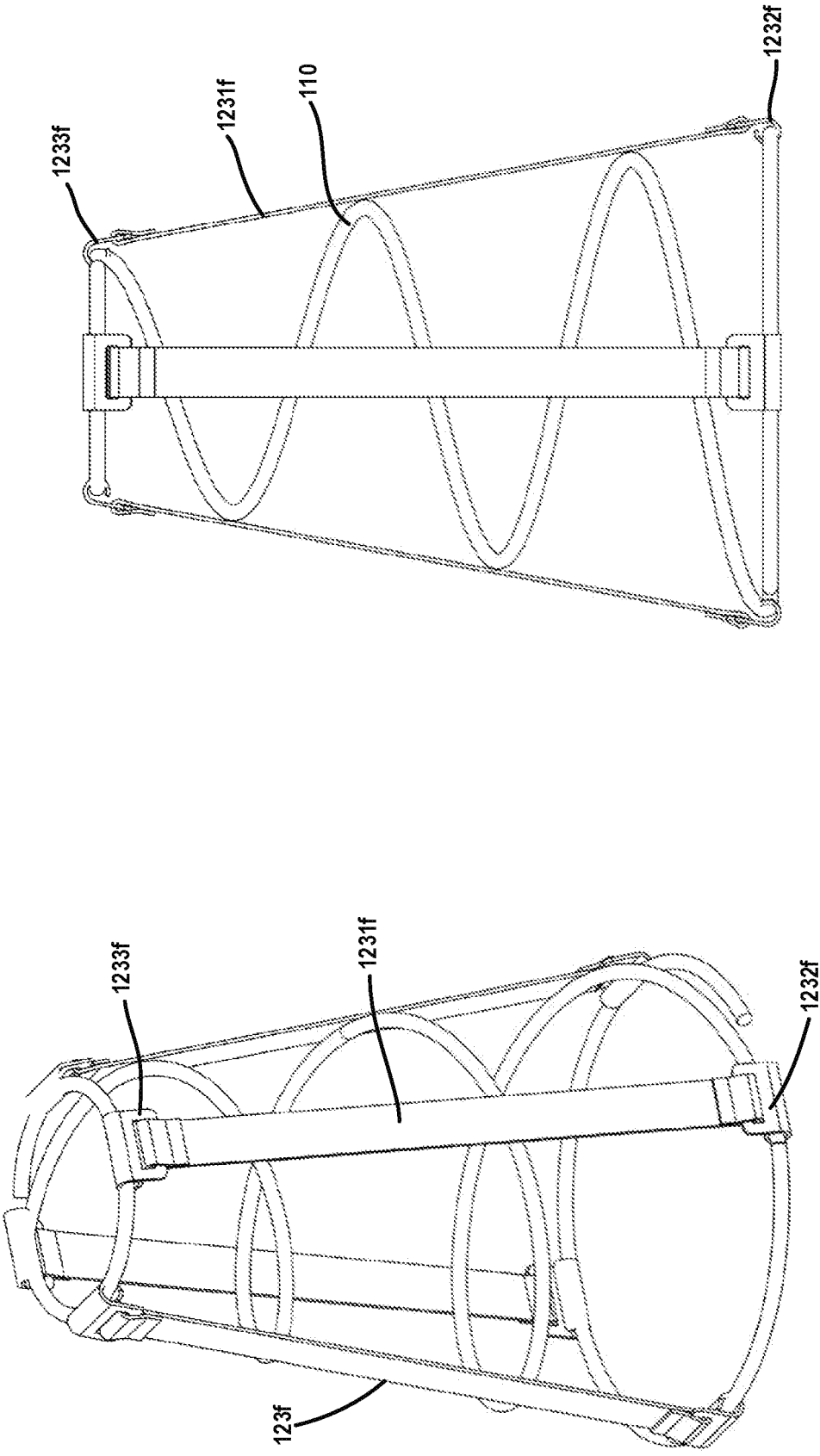

FIG. 35D

FIG. 35C

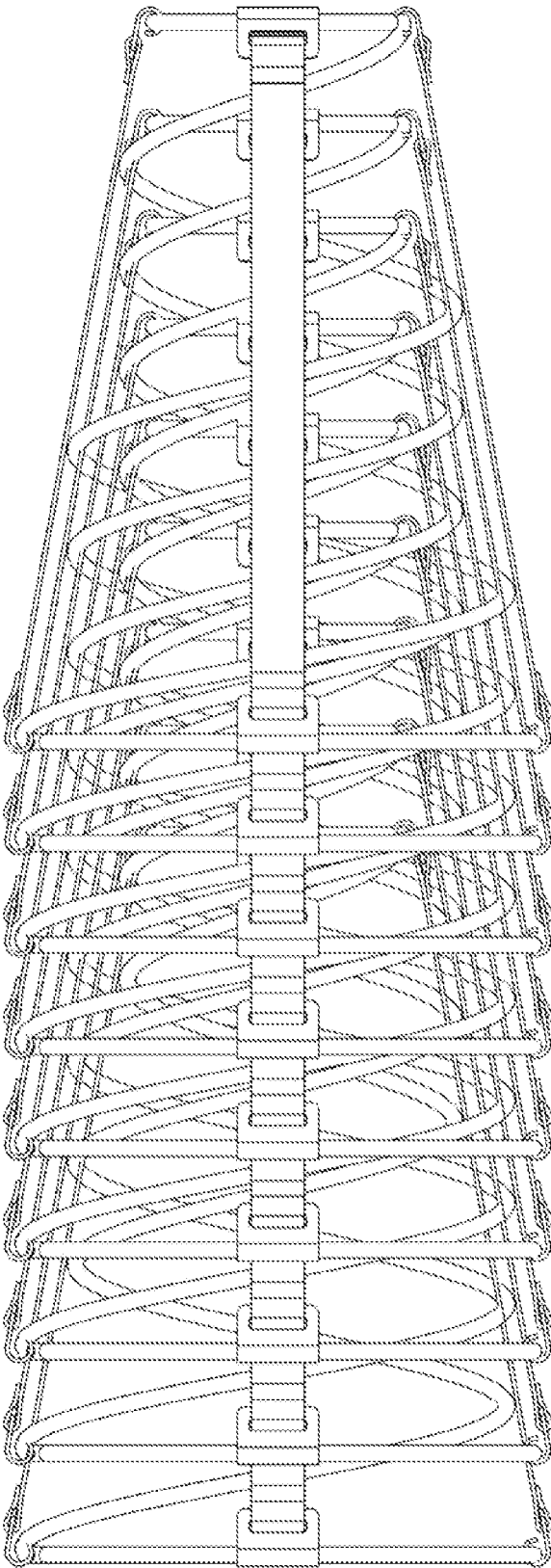

FIG.35E

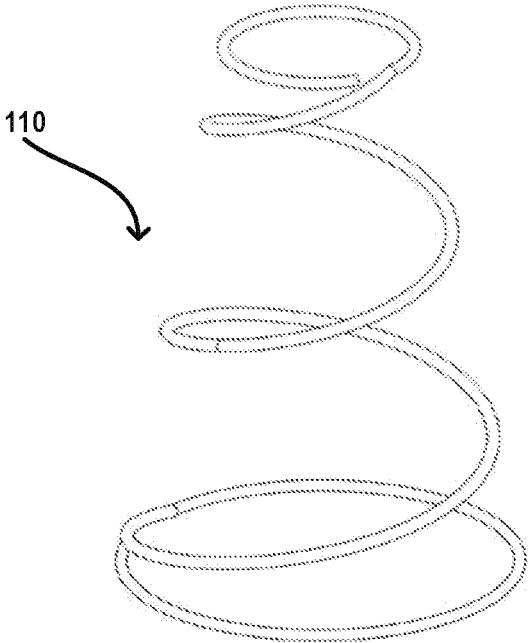
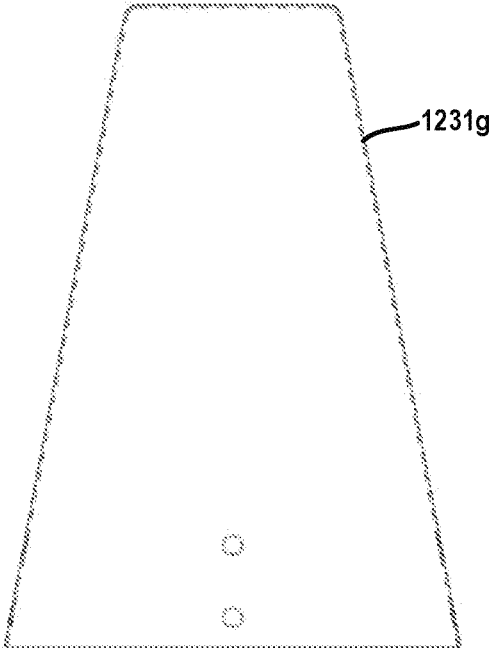

FIG.35F

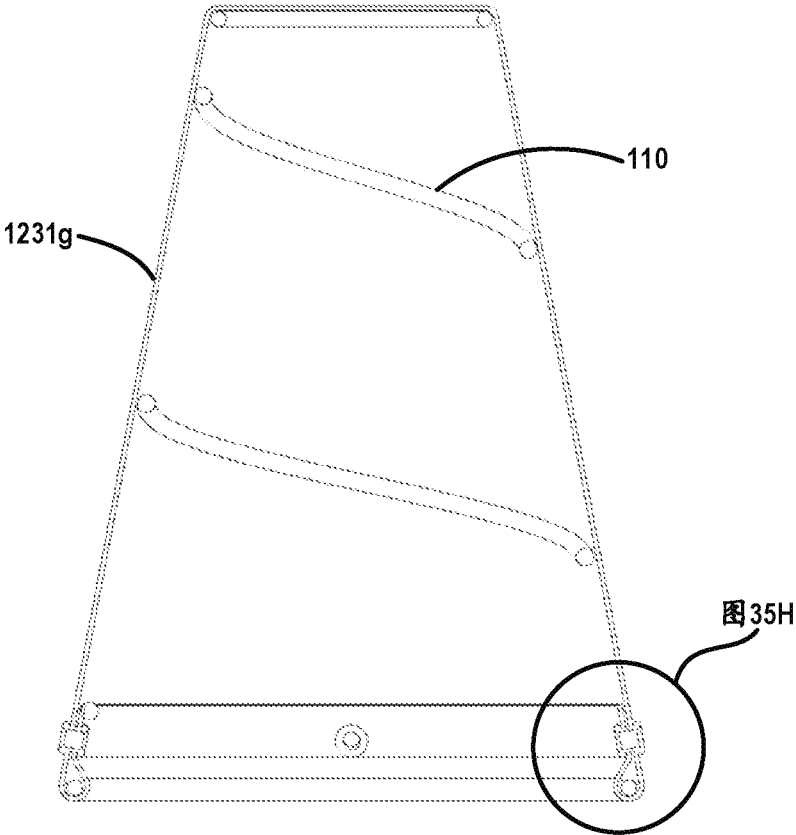

FIG.35G

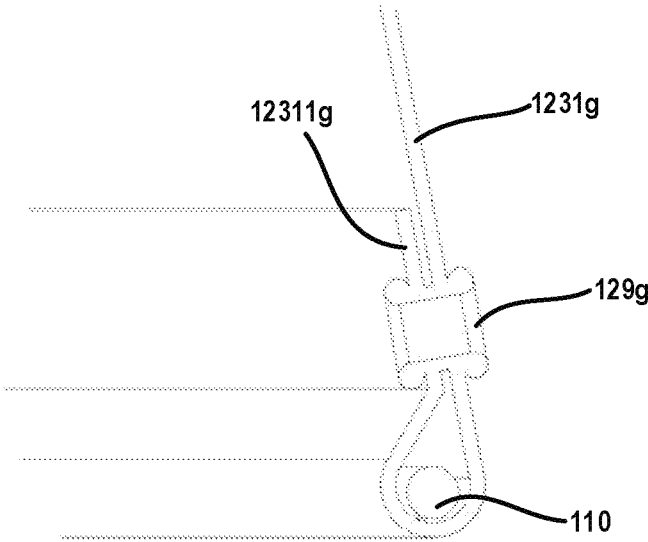

FIG.35H

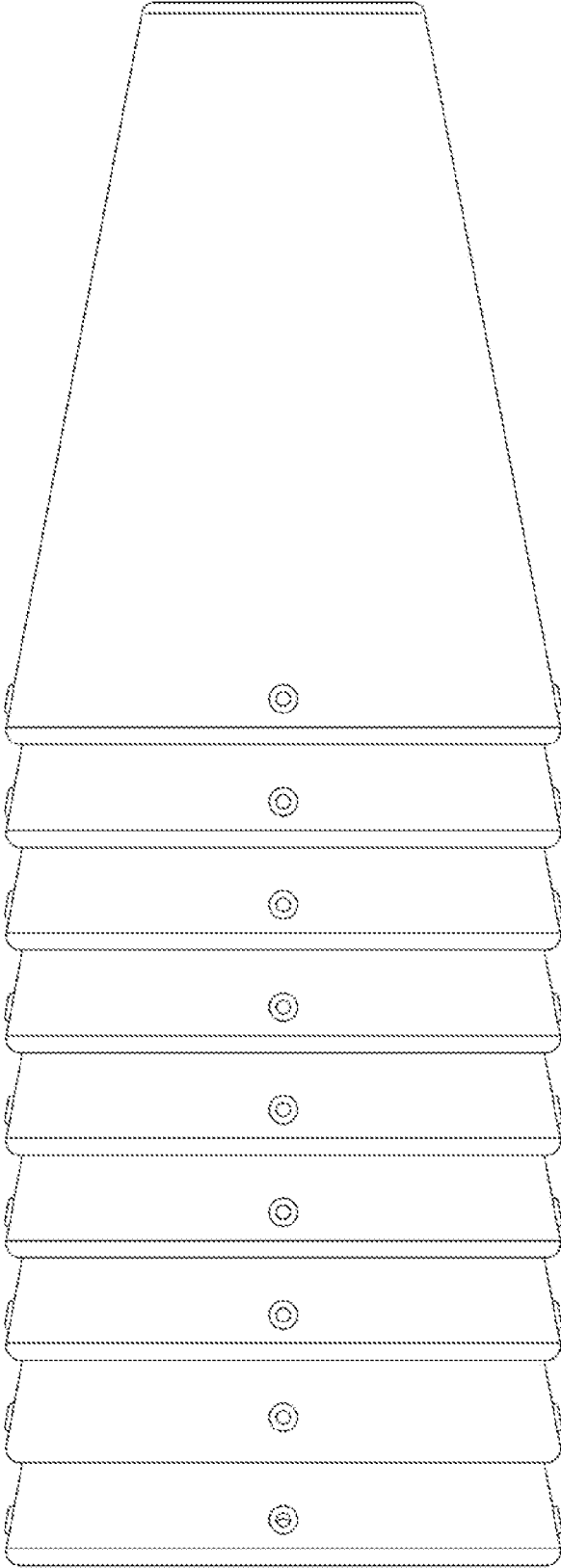

FIG.35I

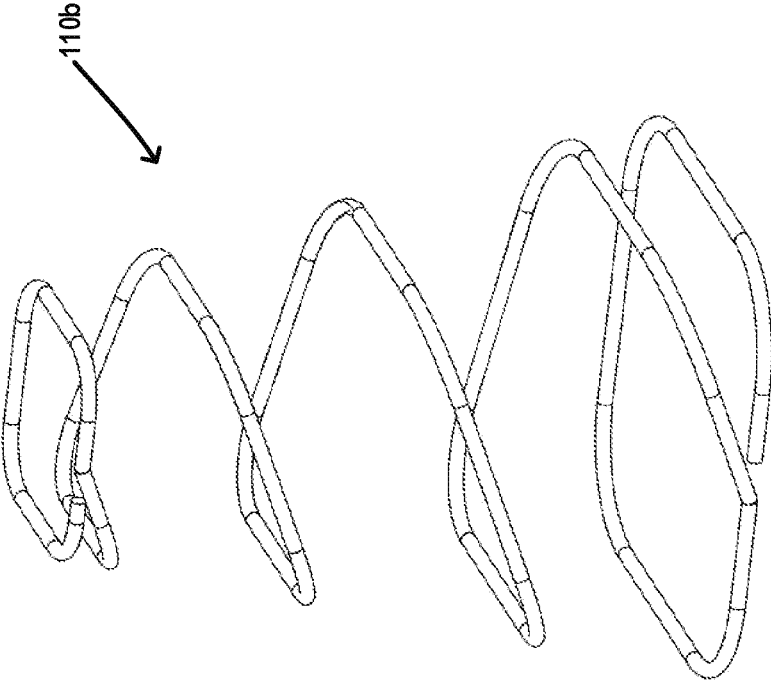

FIG. 35K

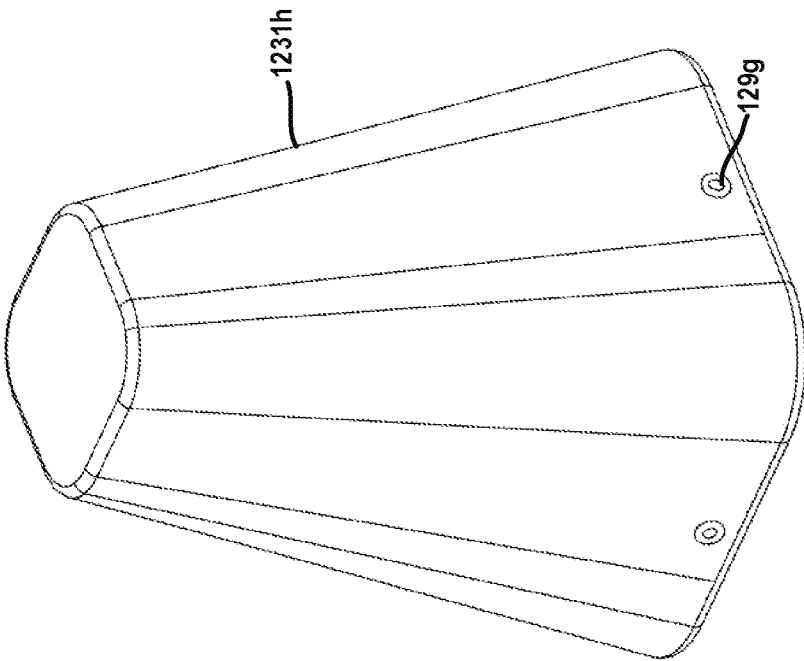

FIG. 35J

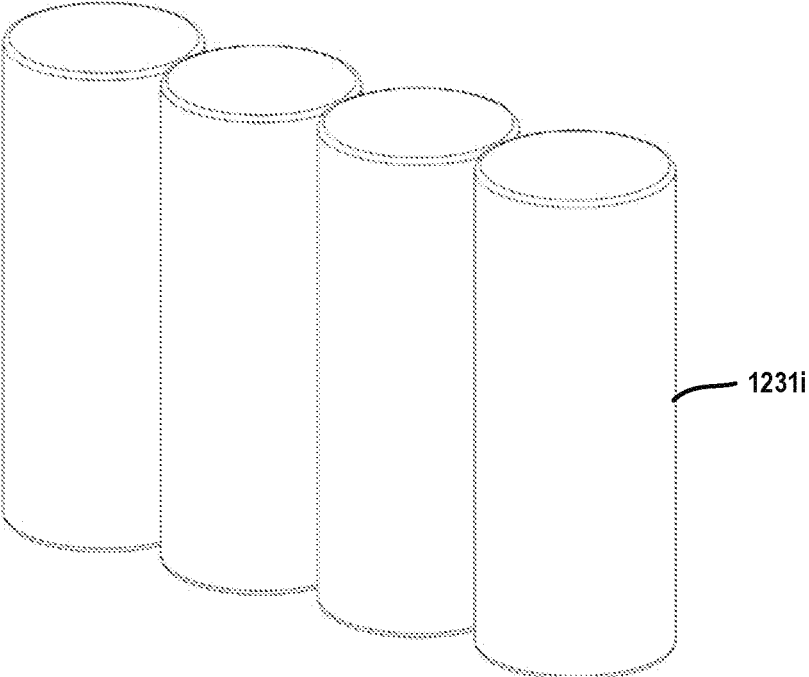

FIG.36A

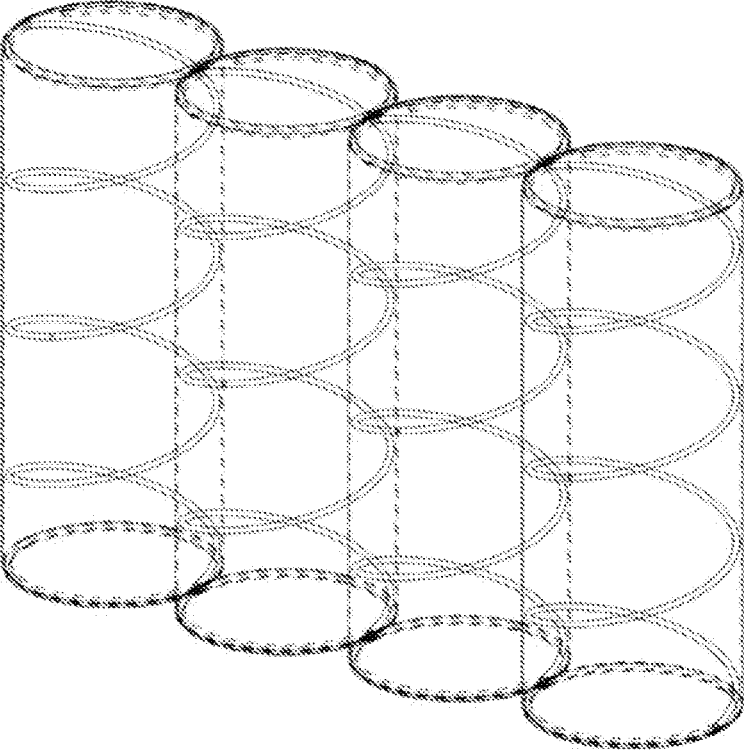

FIG.36B

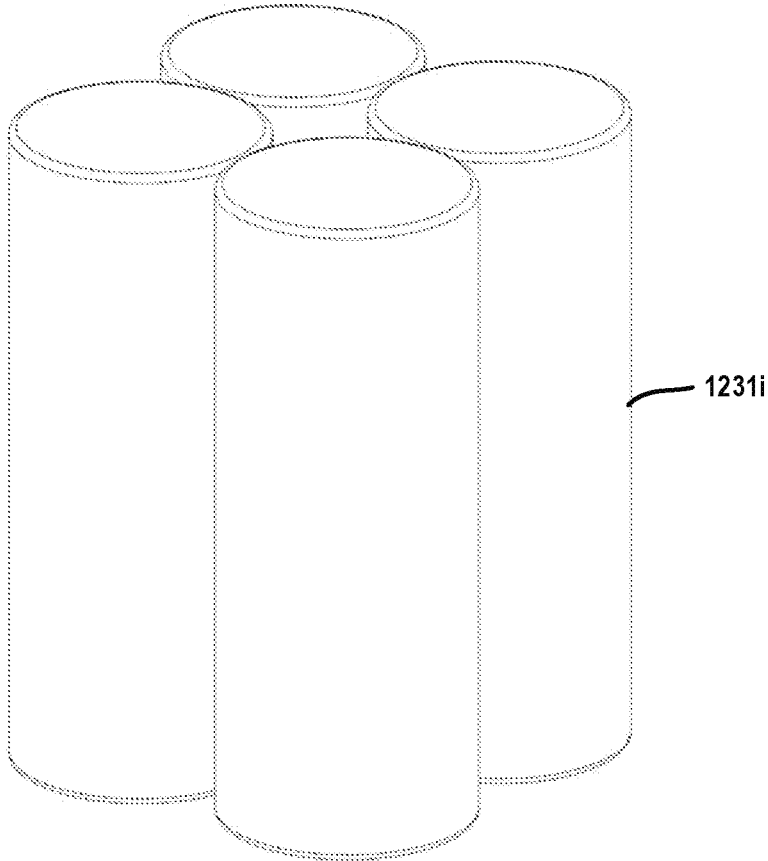

FIG.36C

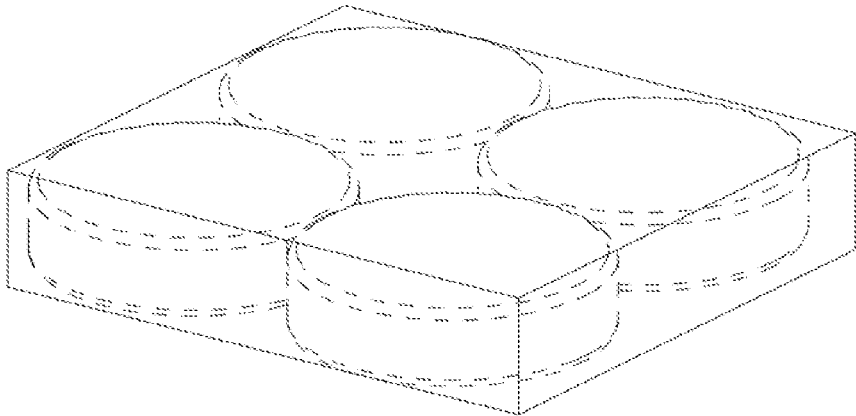

FIG.36D

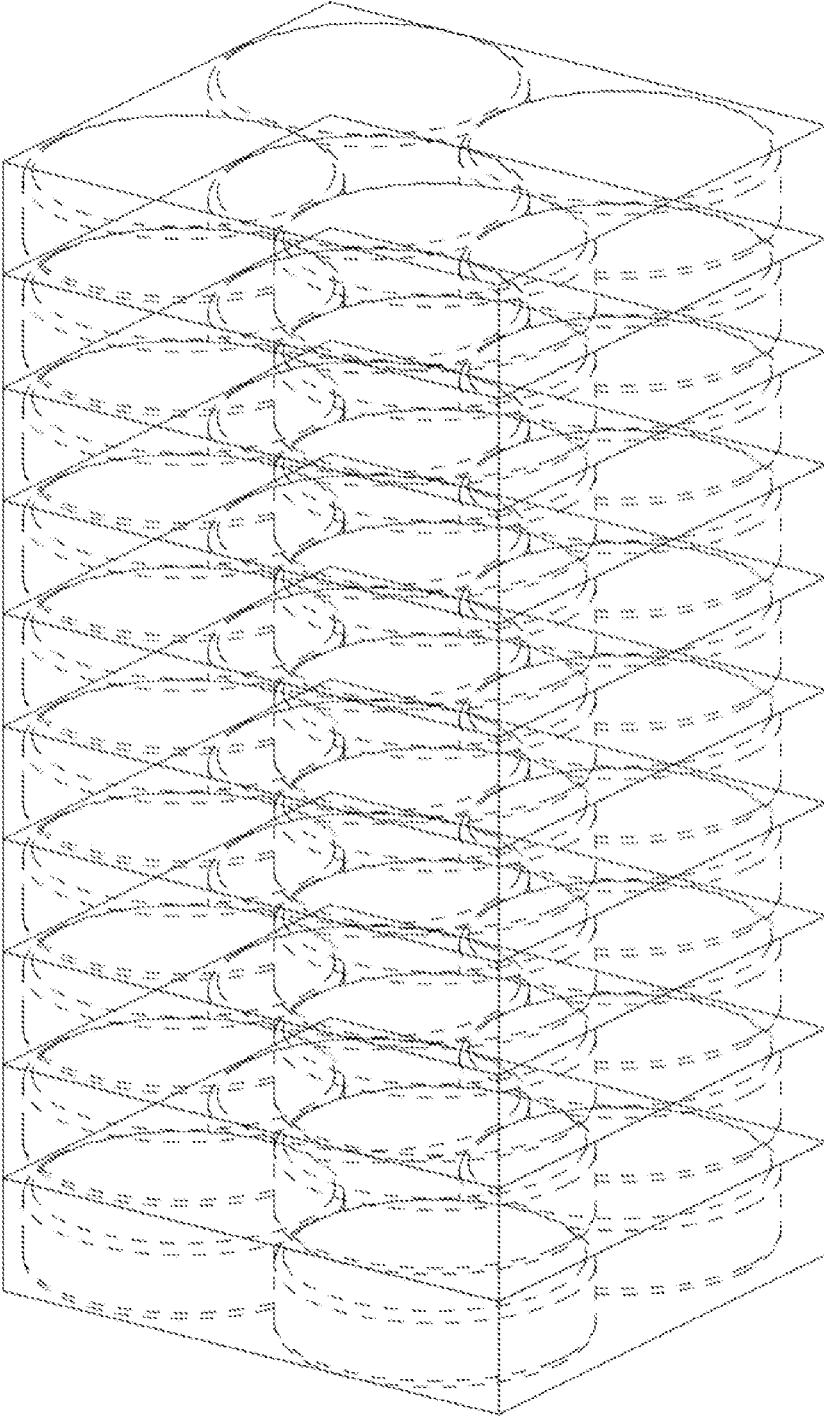

FIG.36E

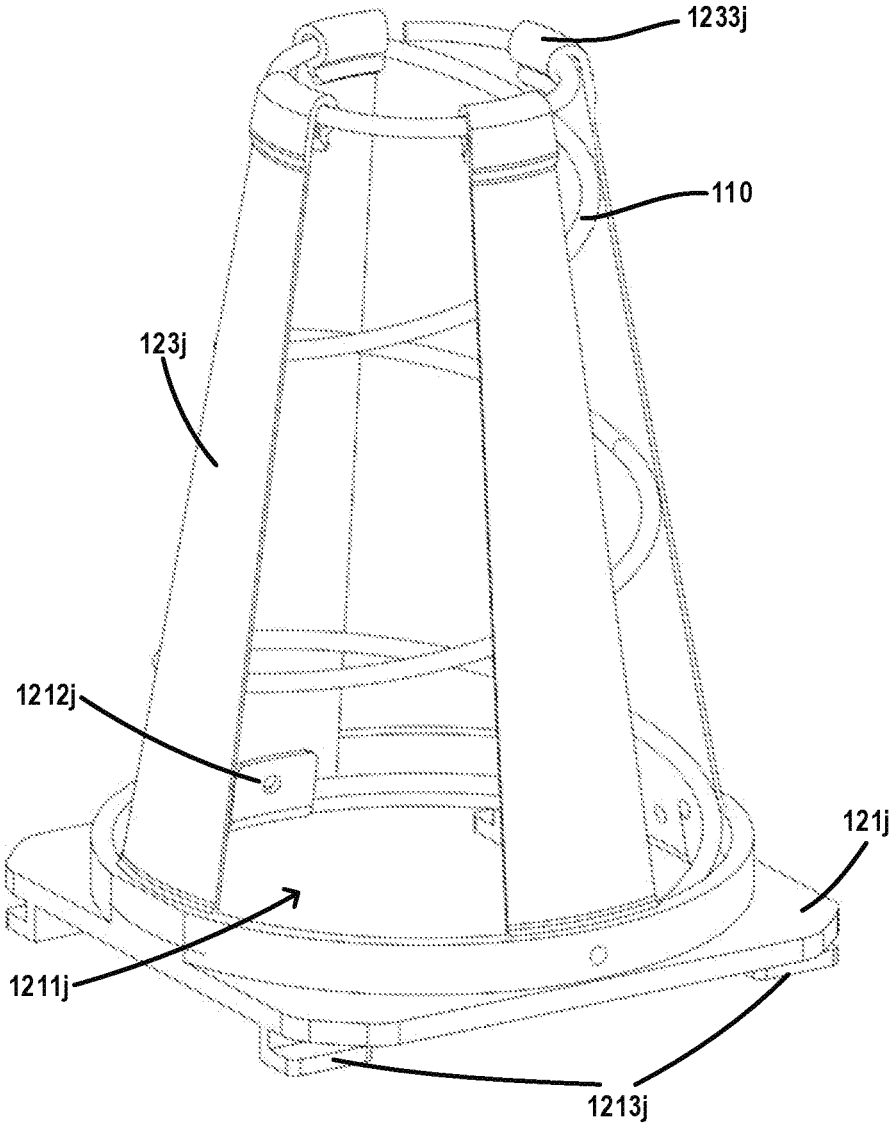

FIG.37

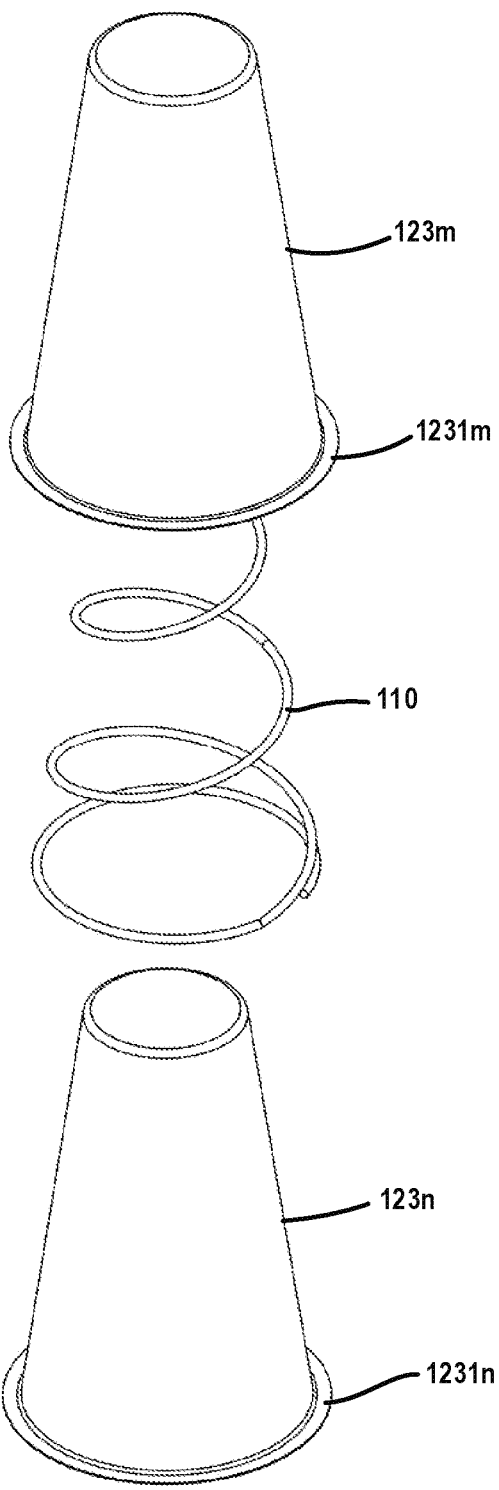

FIG.38A

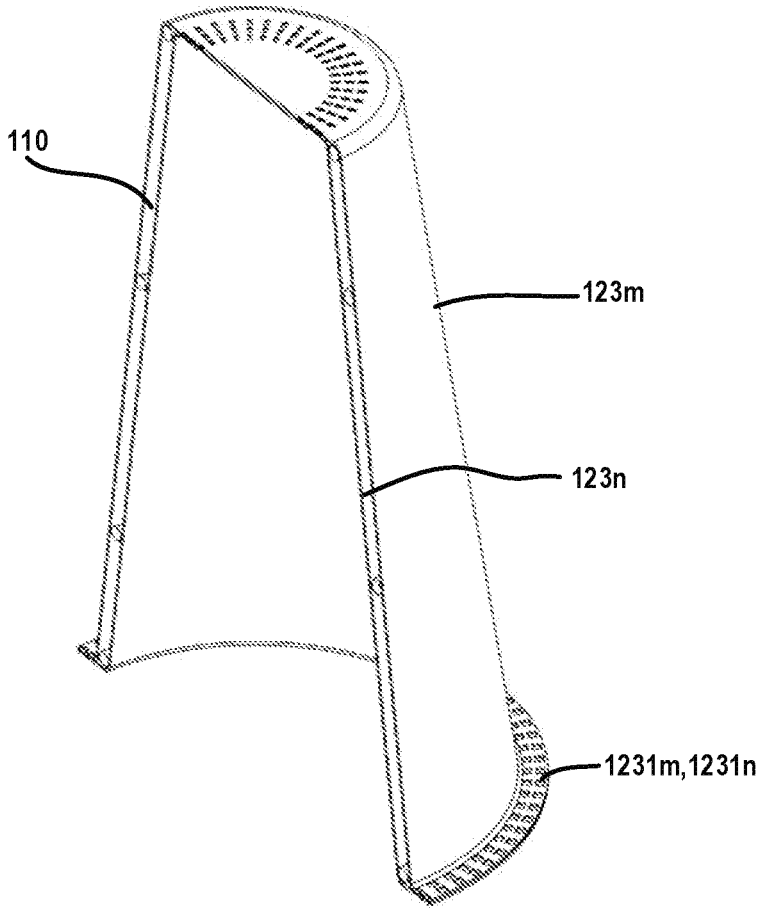

FIG.38B

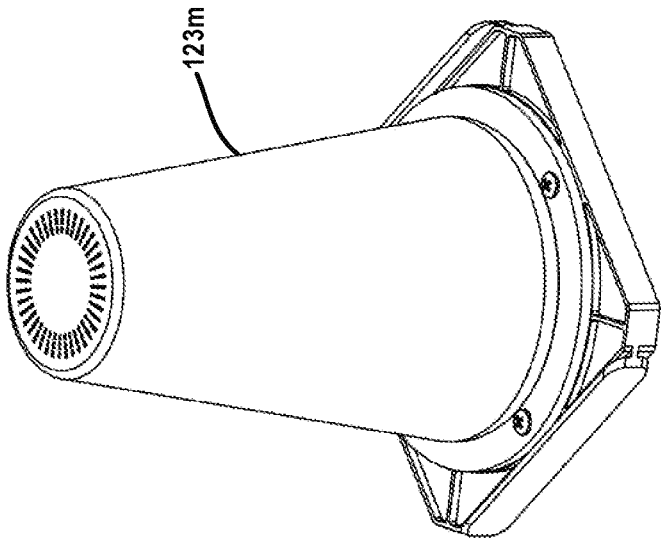

FIG.39B

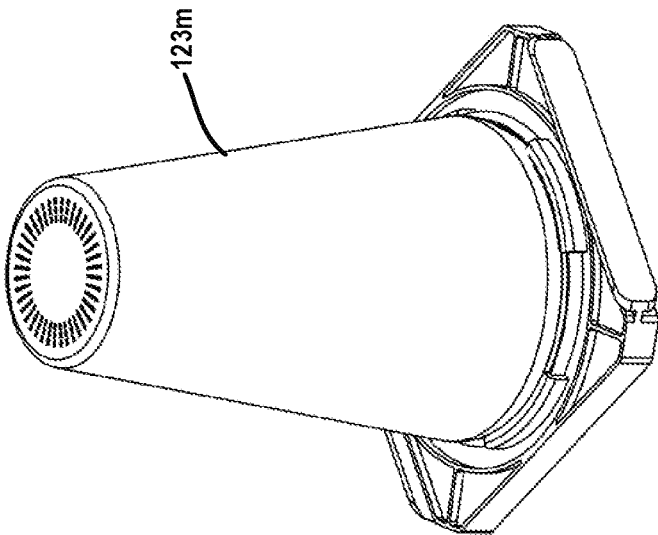

FIG.39A

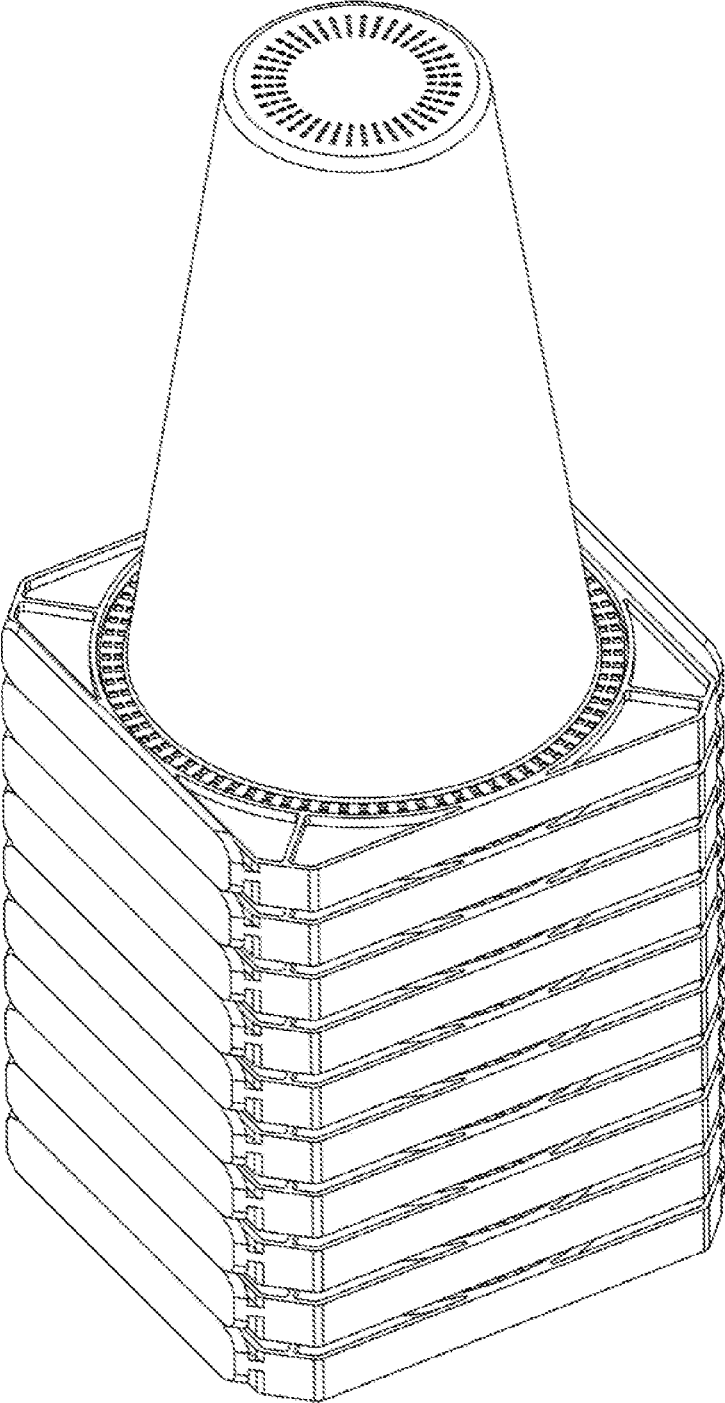

FIG.39C

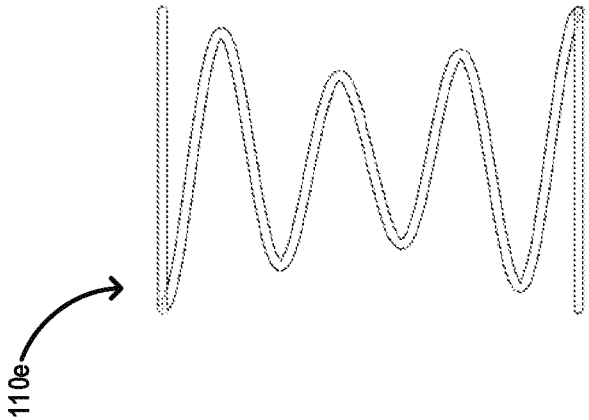

FIG. 40C

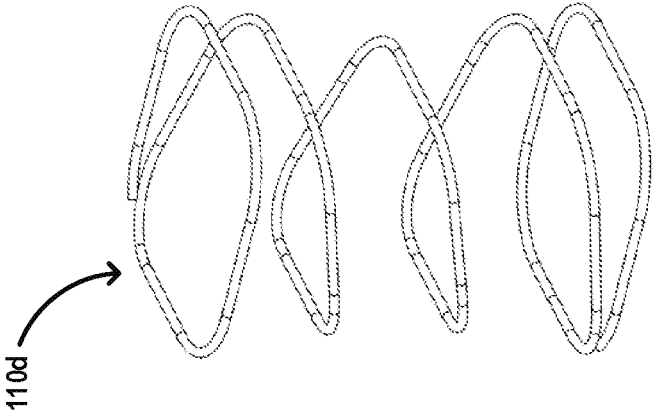

FIG. 40B

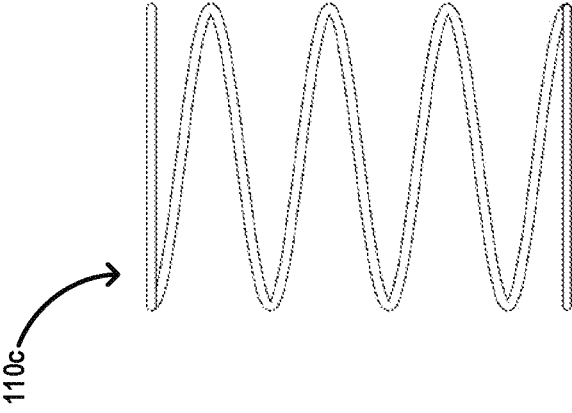

FIG. 40A

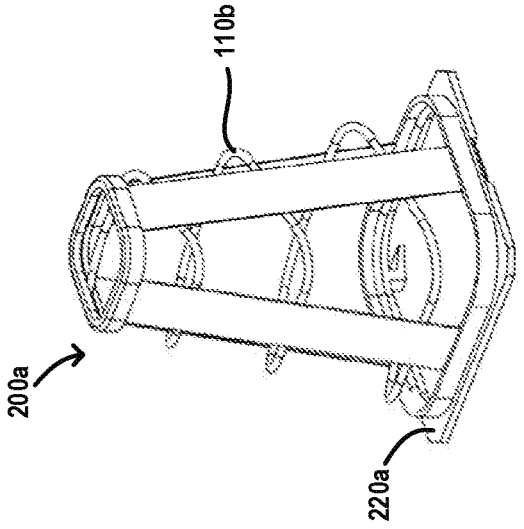

FIG. 40F

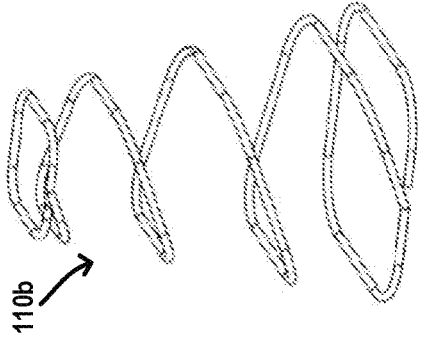

FIG. 40E

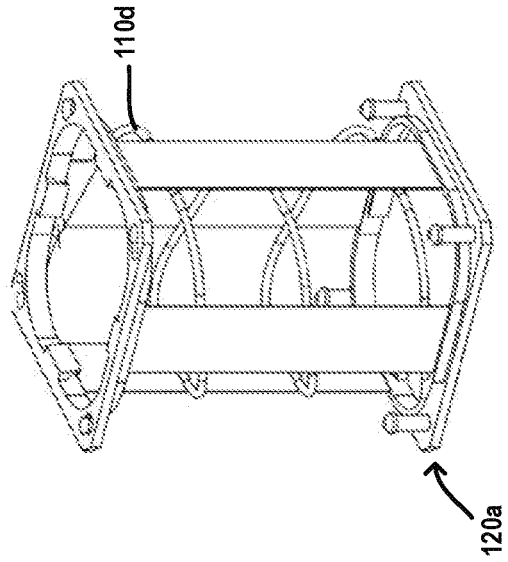

FIG. 40D

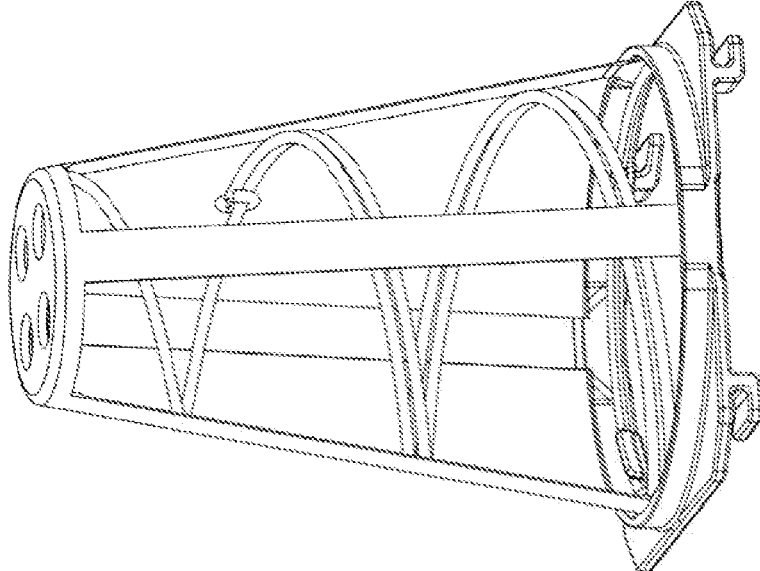
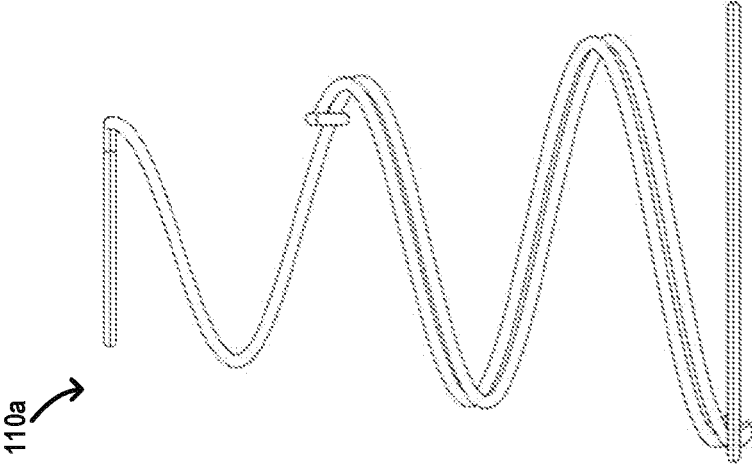

FIG. 40H



110a

FIG. 40G

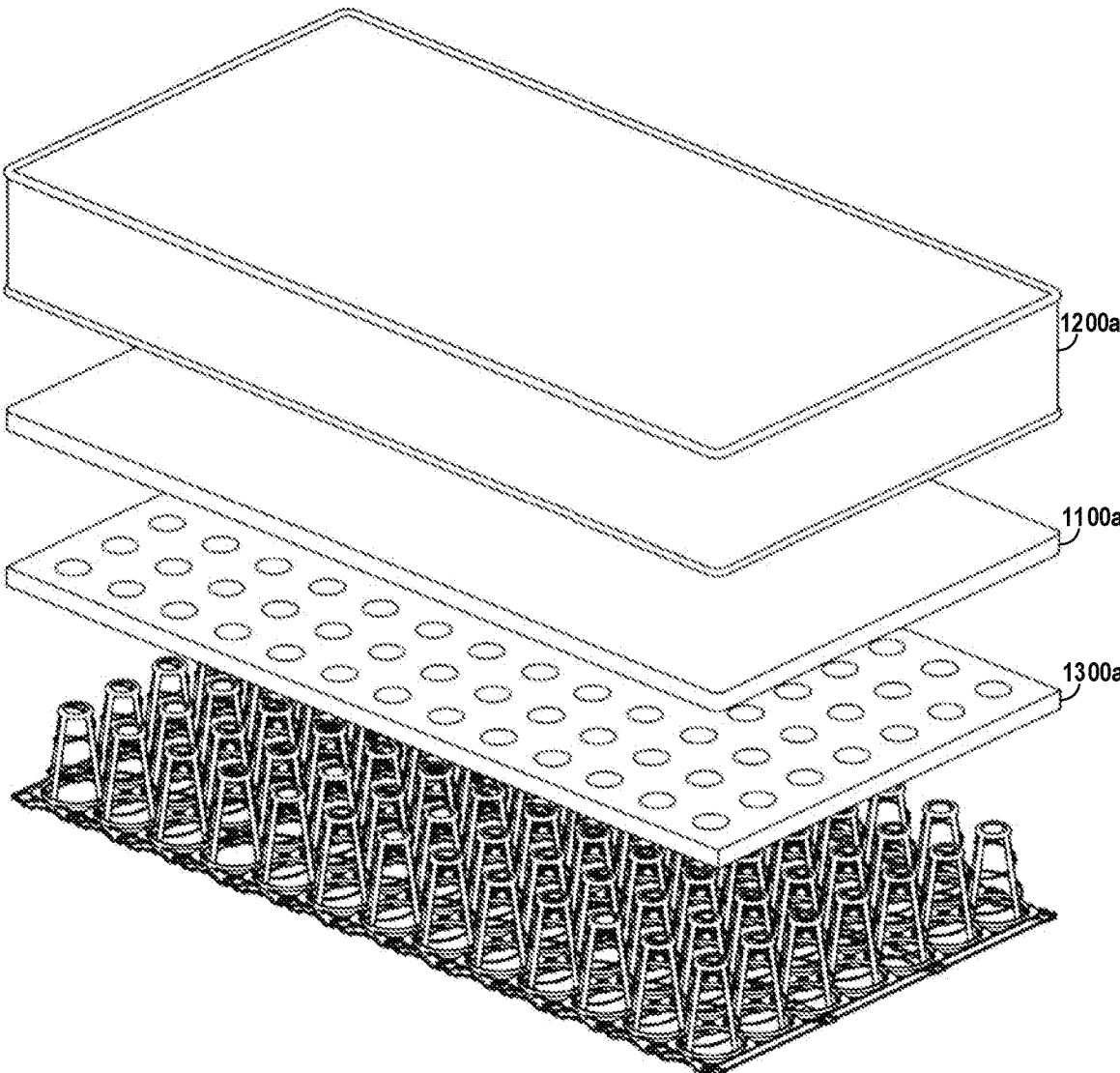

FIG.41A

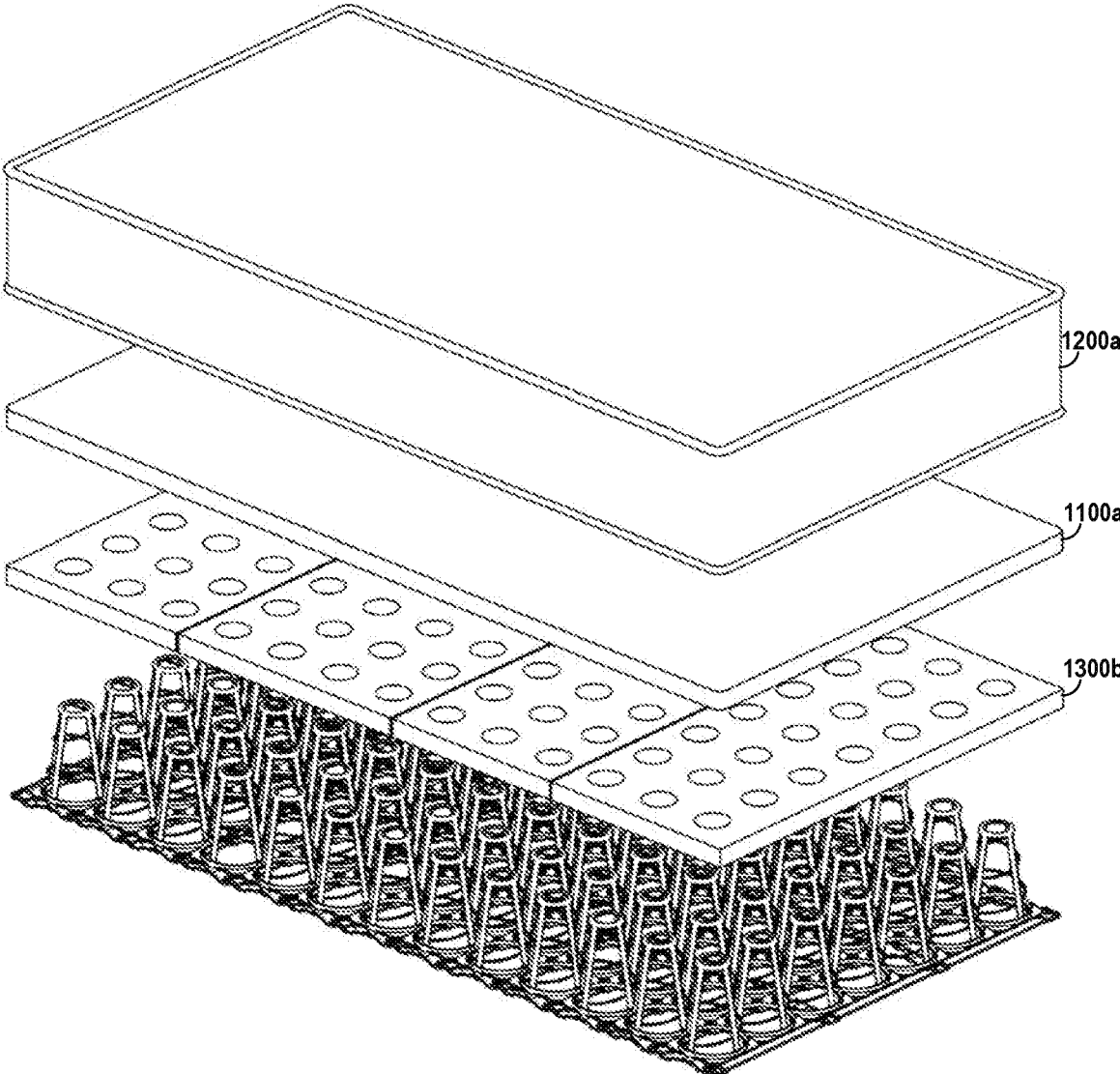

FIG.41B

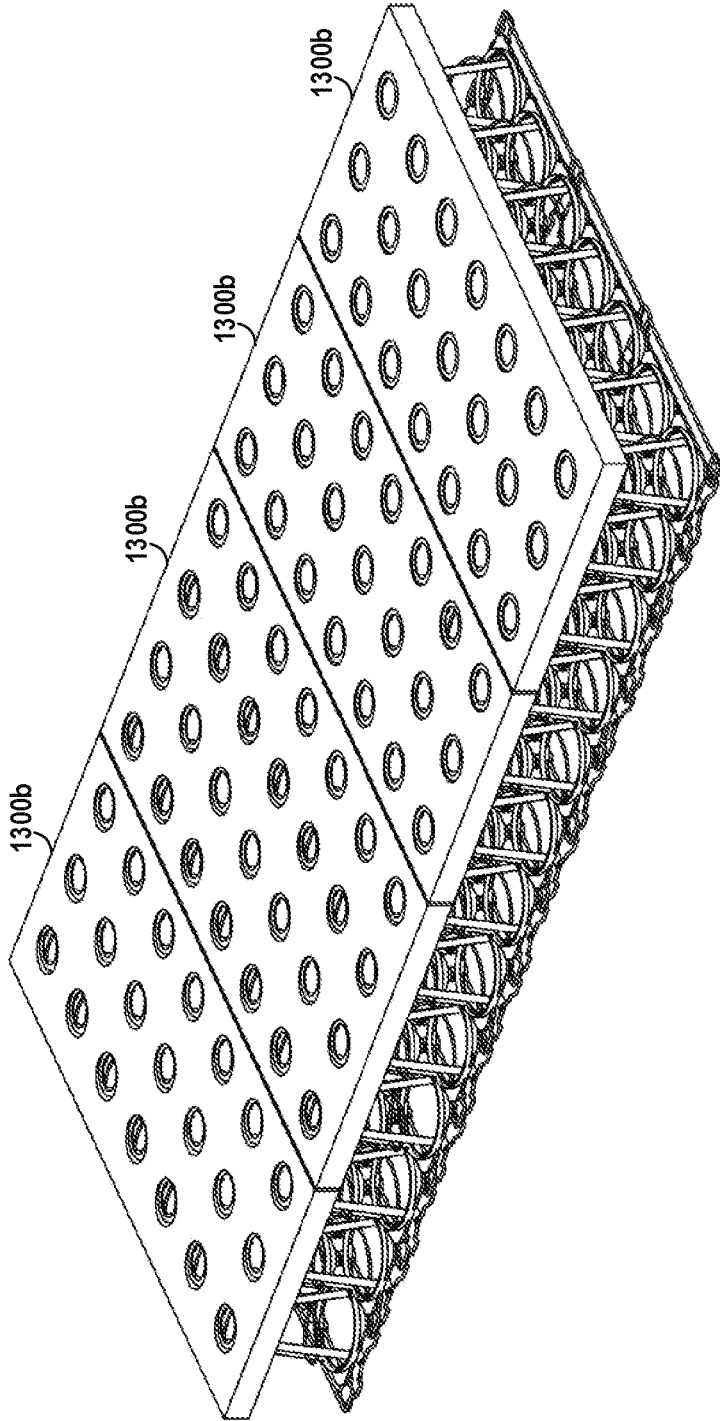

FIG.41C

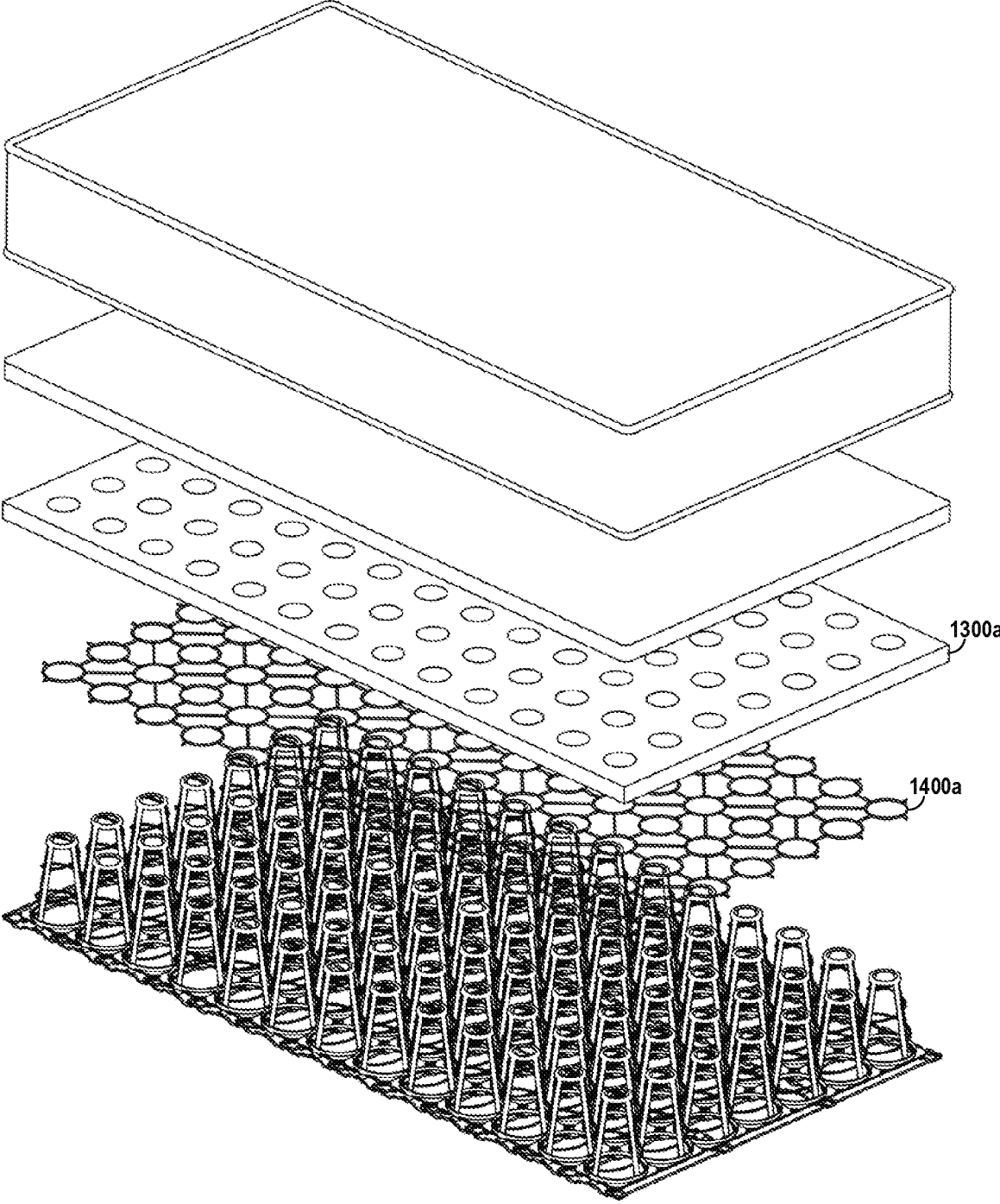

FIG.41D

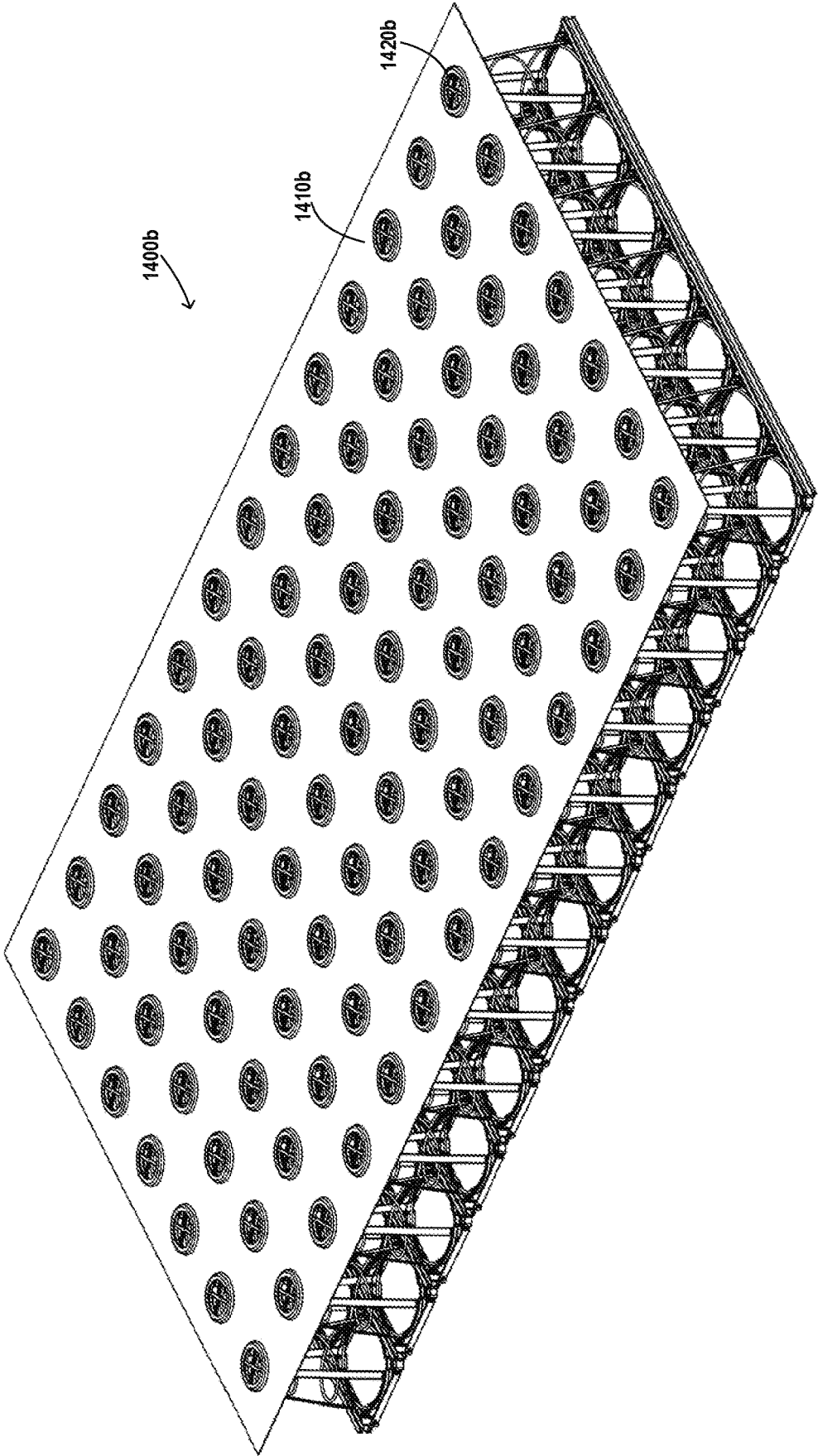

FIG.42A

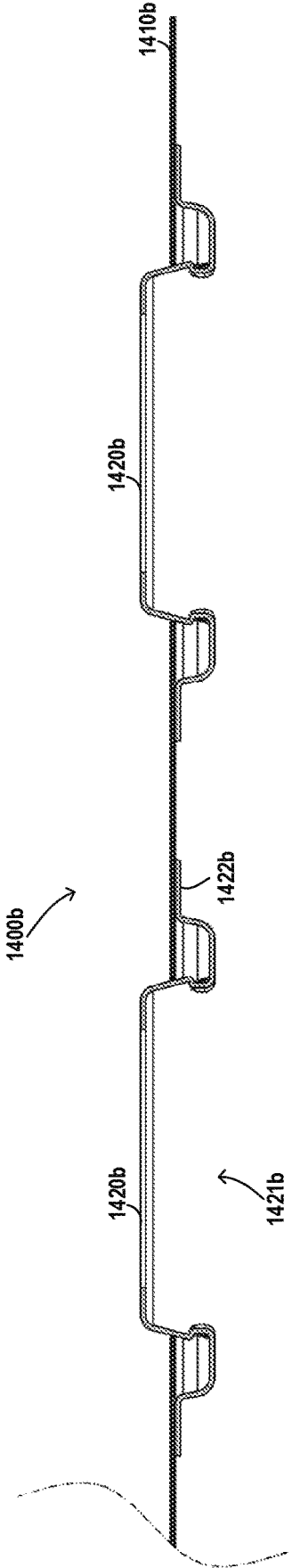

FIG. 42B

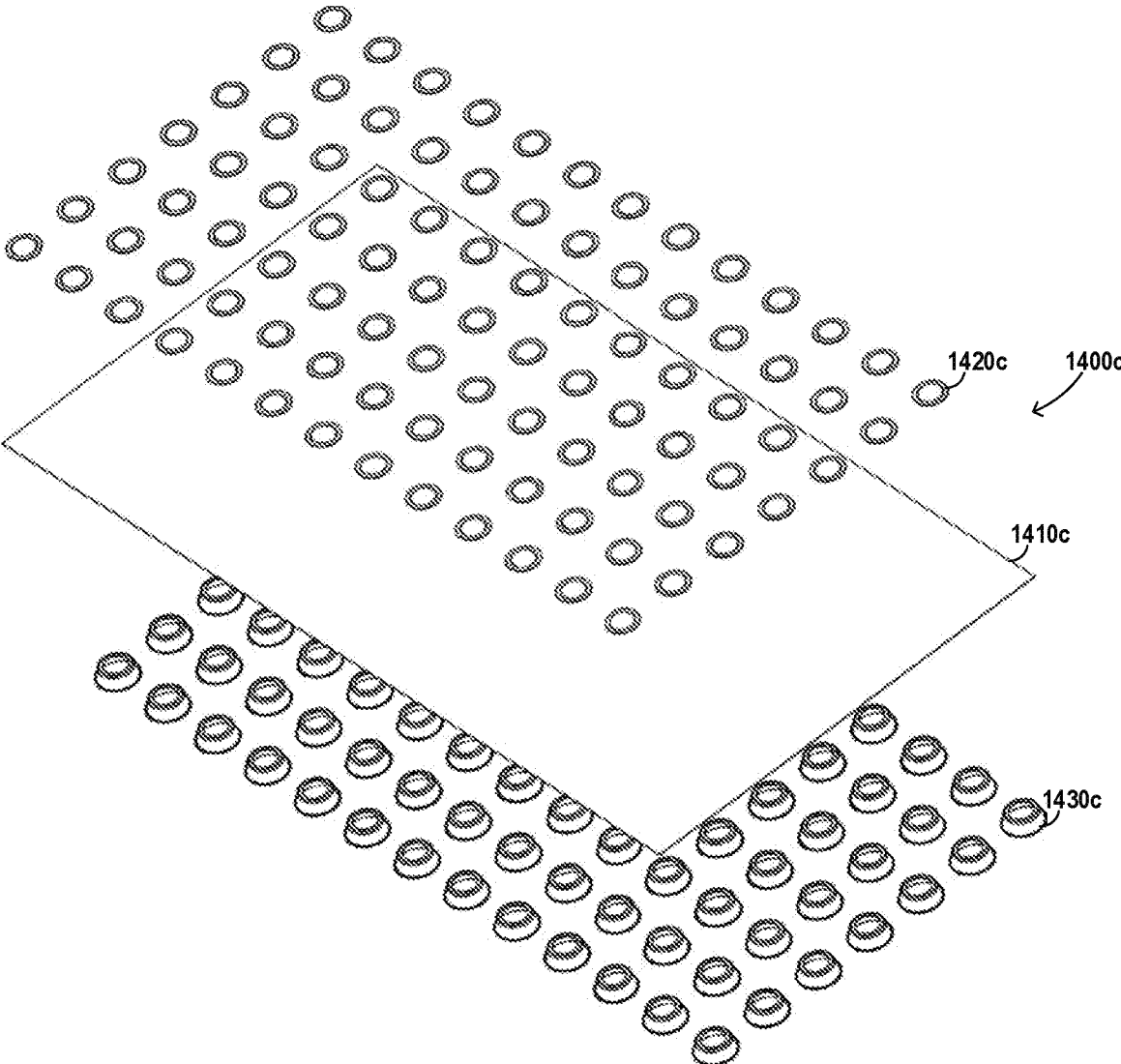

FIG.42C

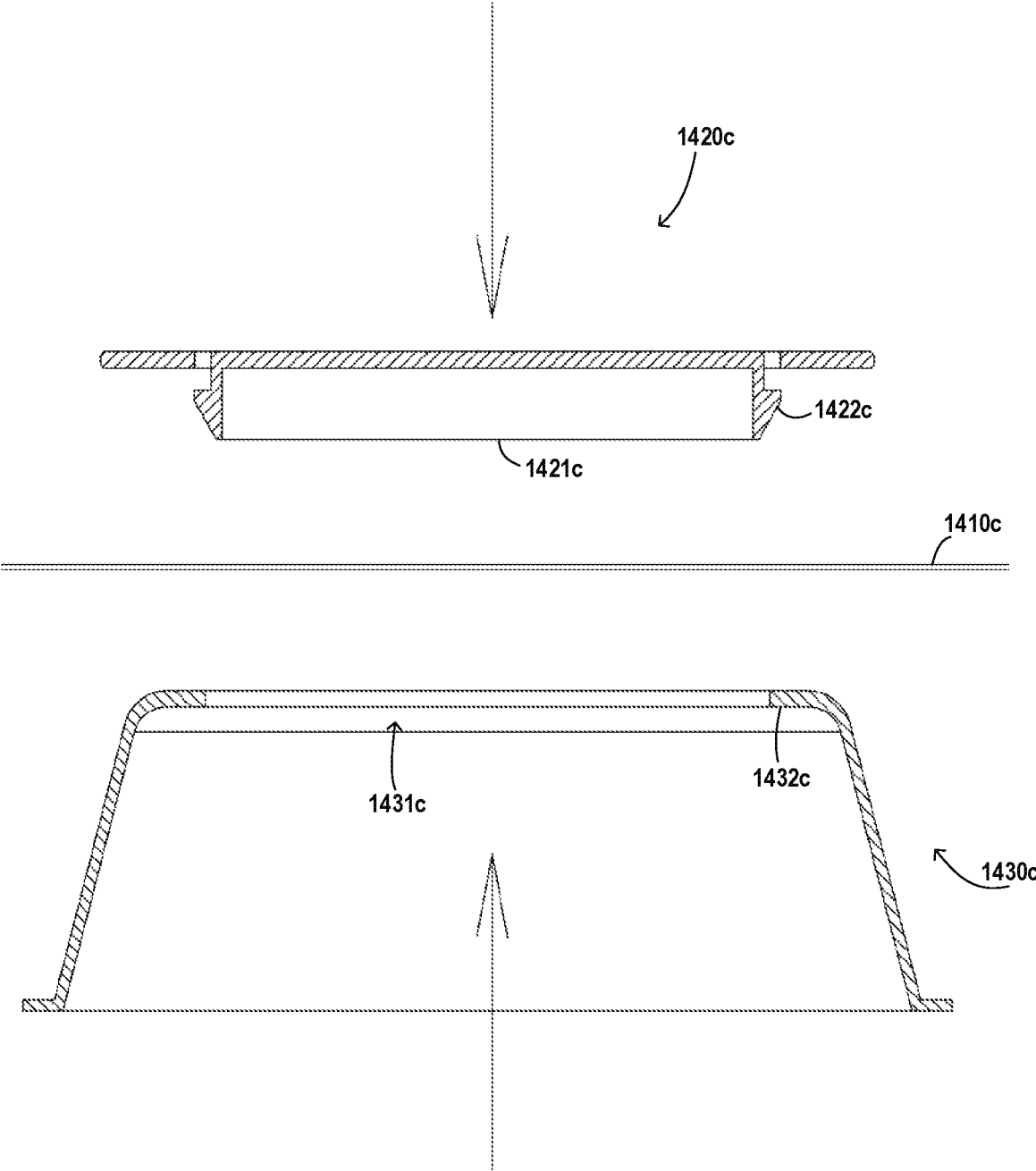

FIG.42D

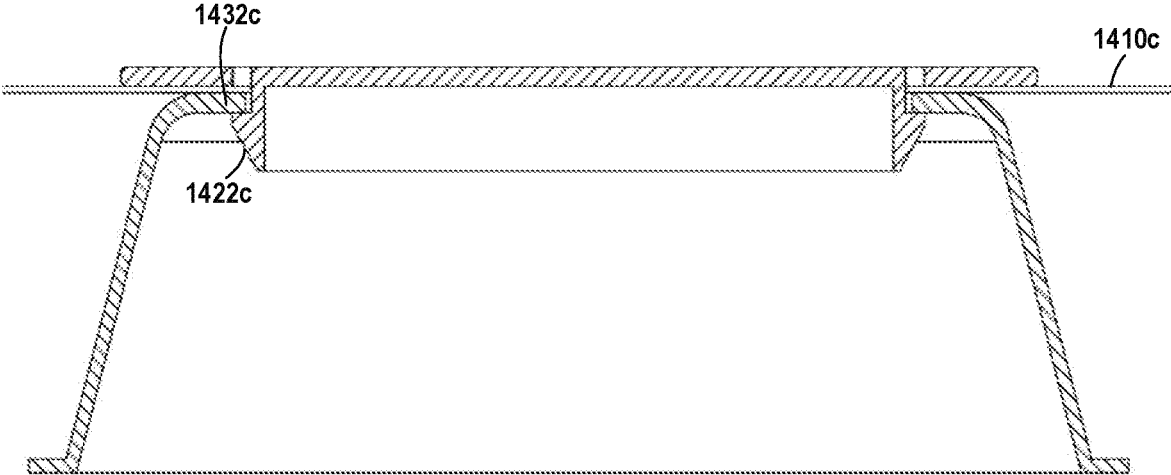

FIG.42E

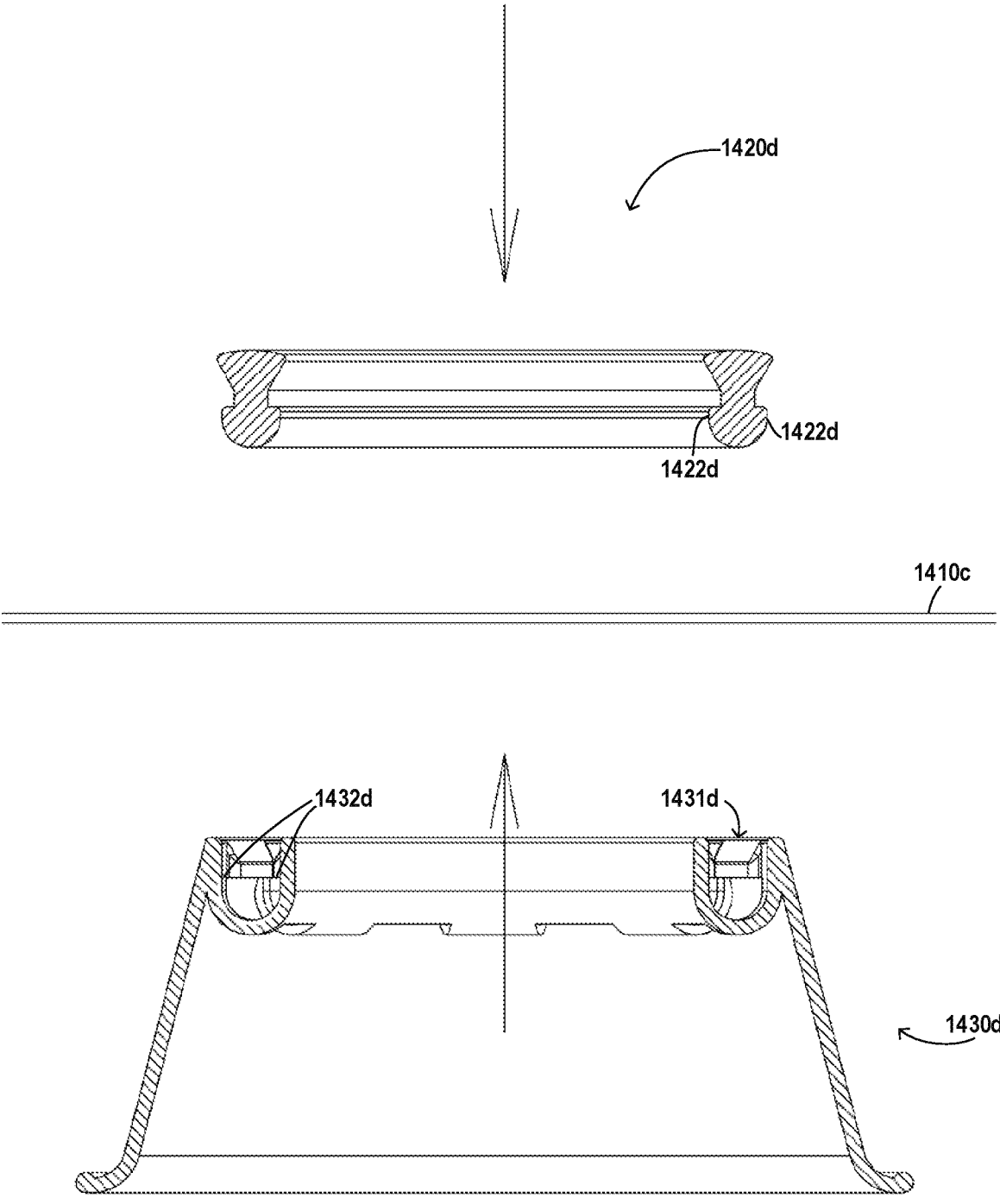

FIG.42F

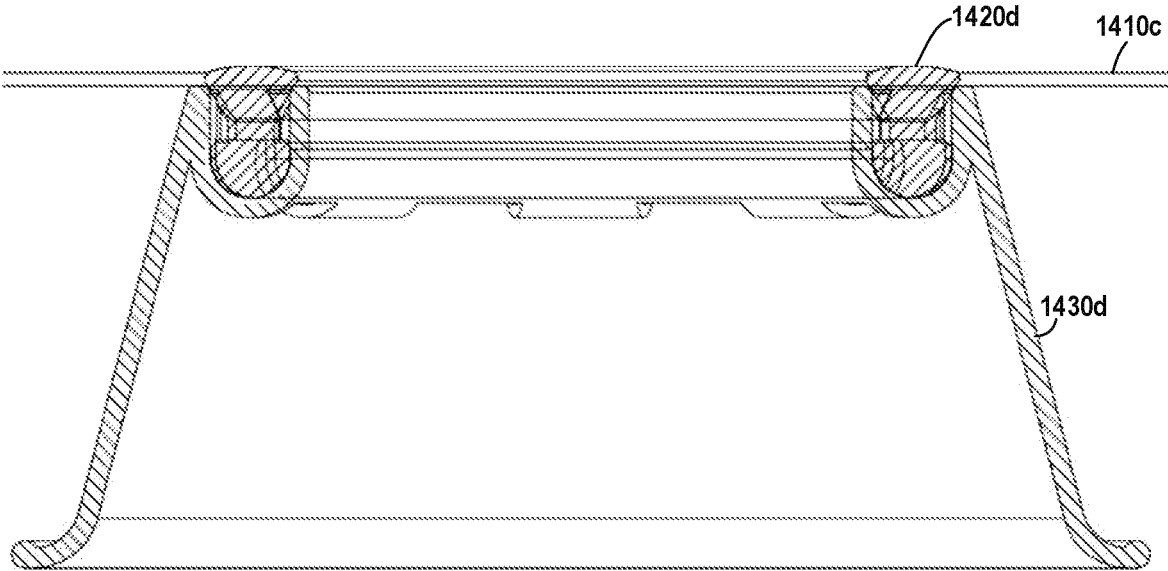

FIG.42G

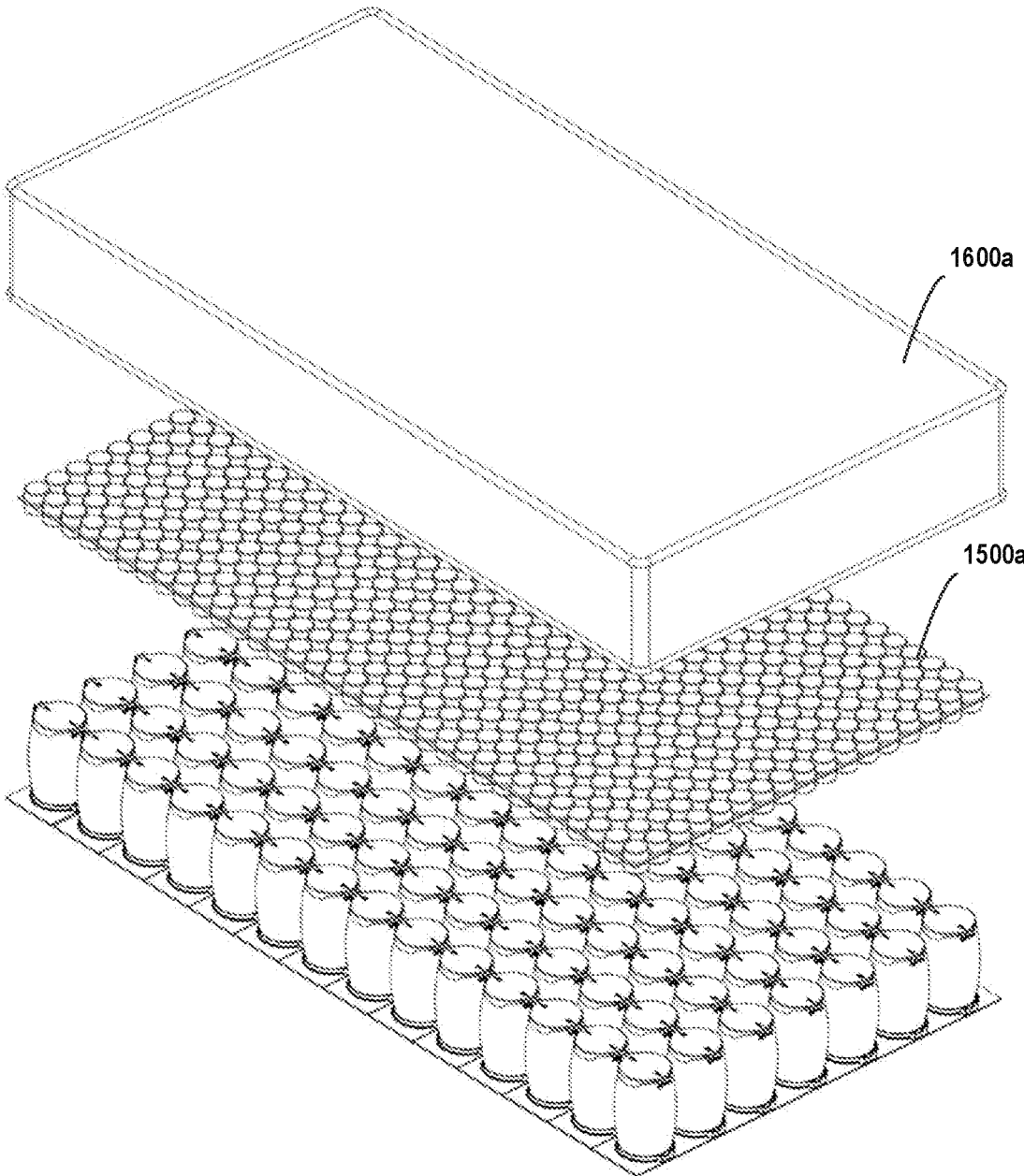

FIG.42H

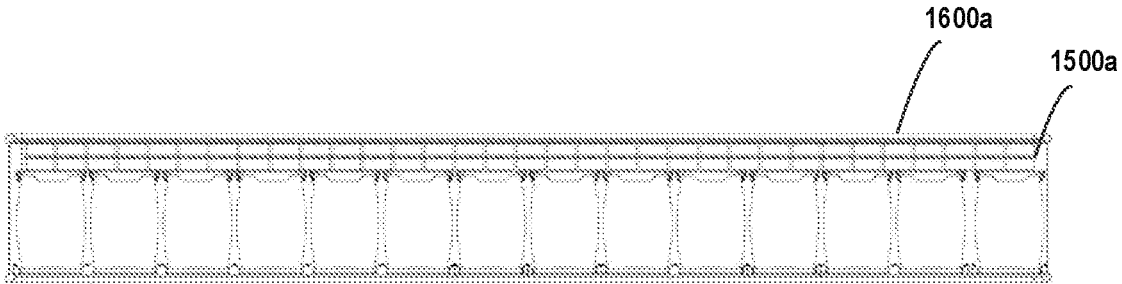

FIG.42I

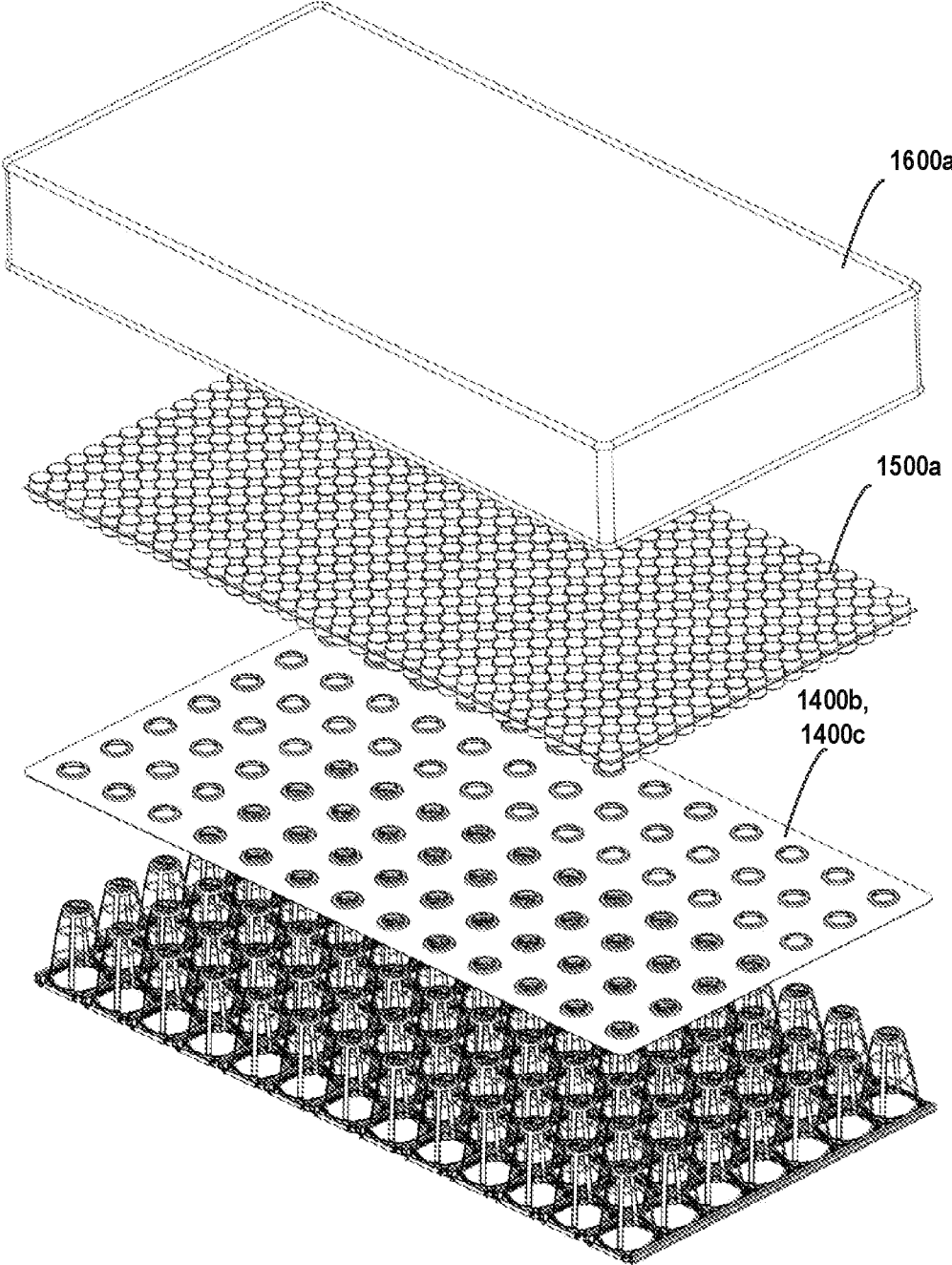

FIG.42J

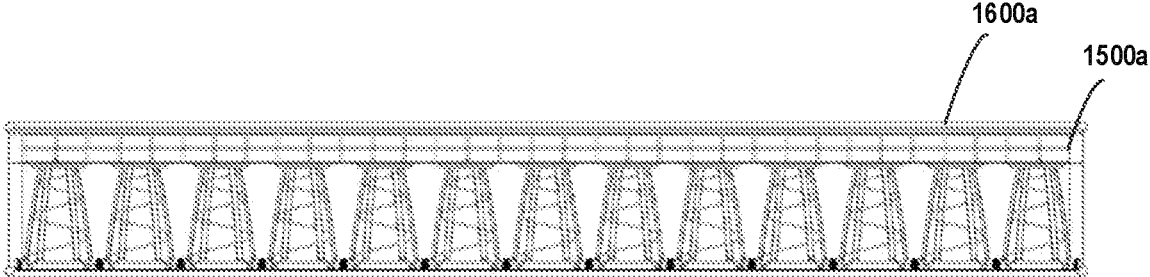

FIG.42K

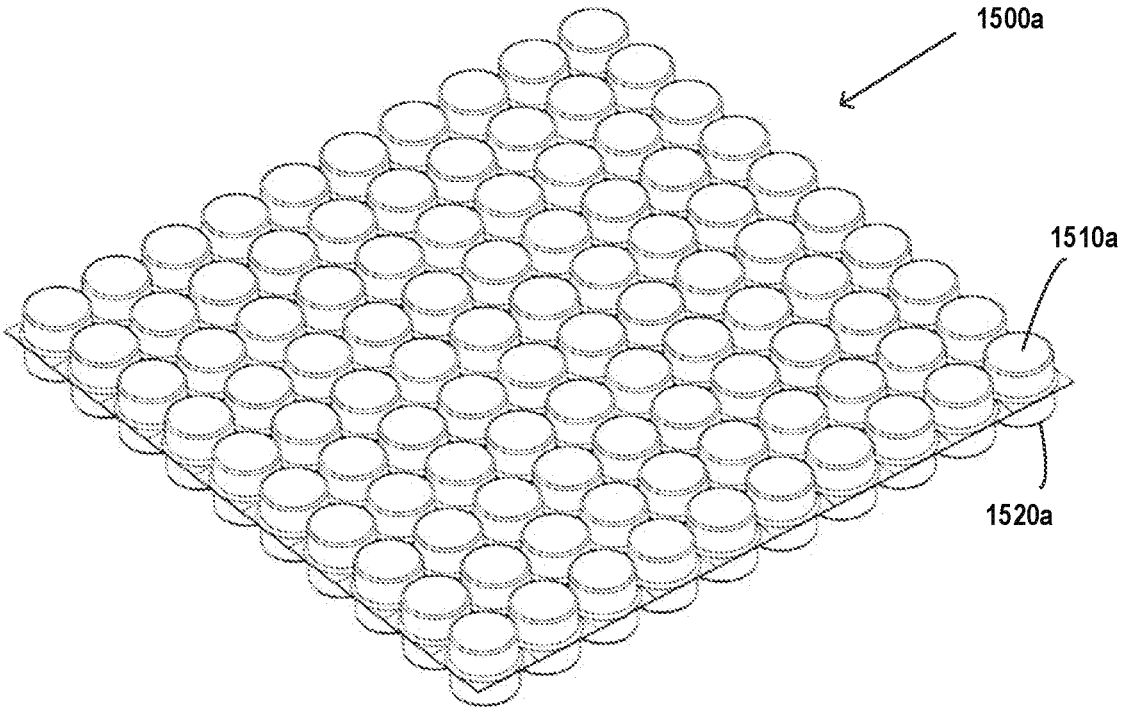

FIG.42L

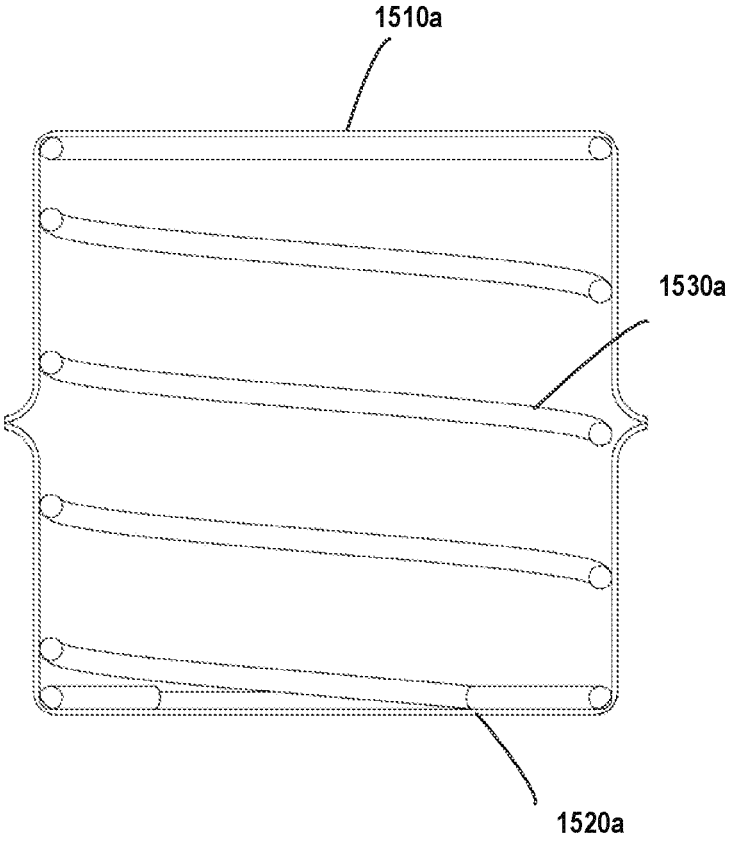

FIG.42M

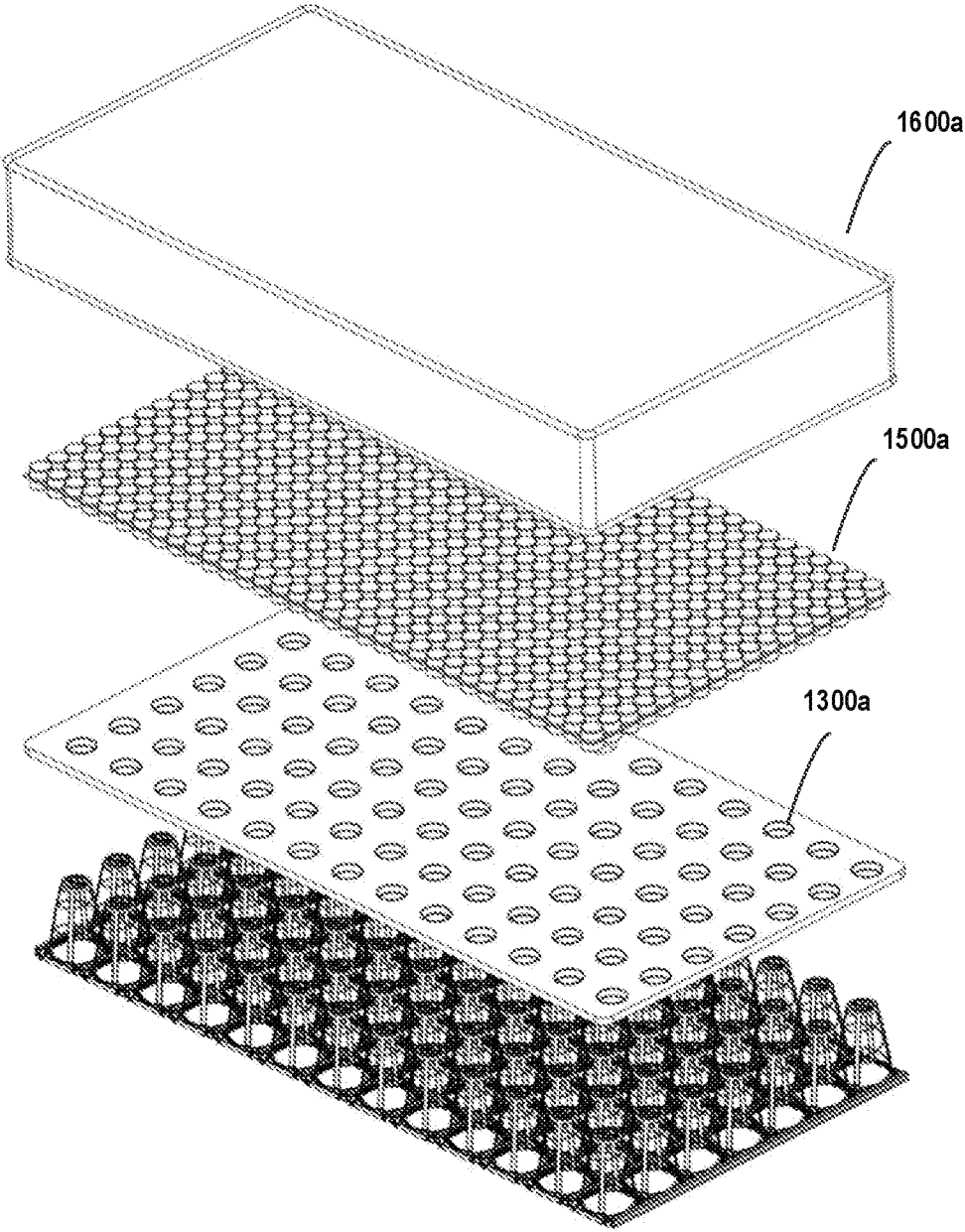

FIG.42N

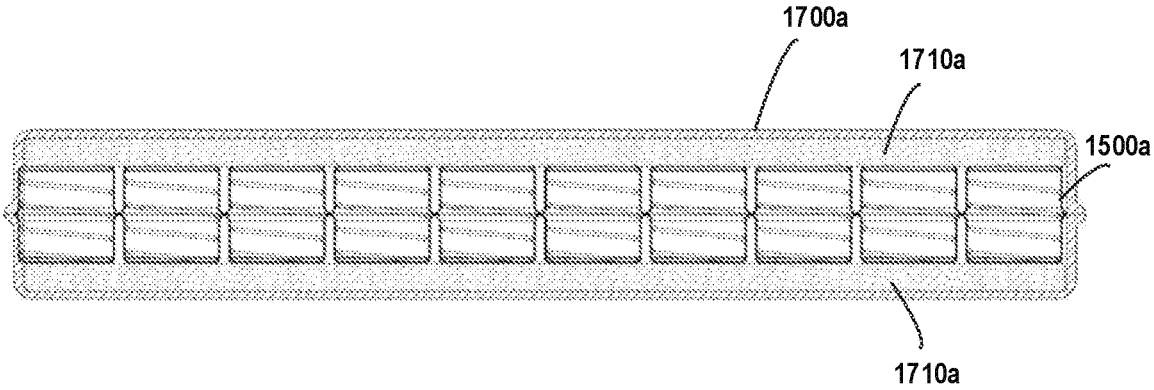

FIG. 42P

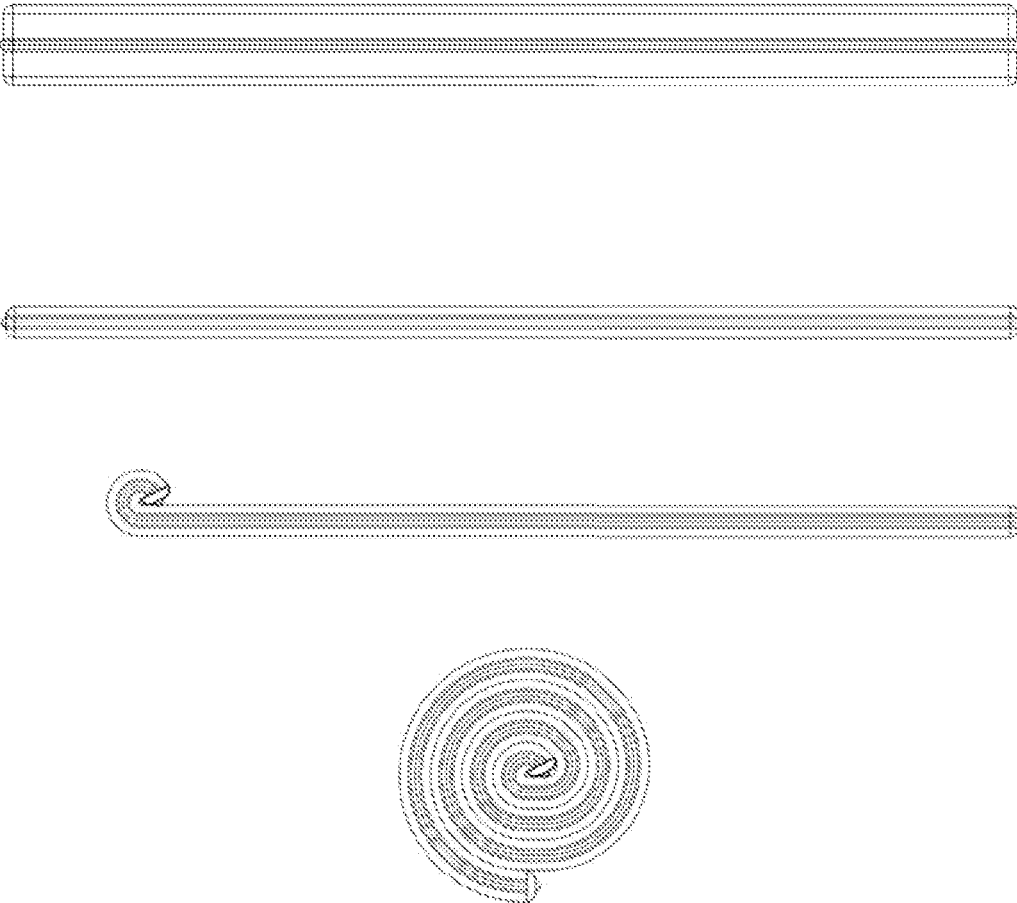

FIG.42Q

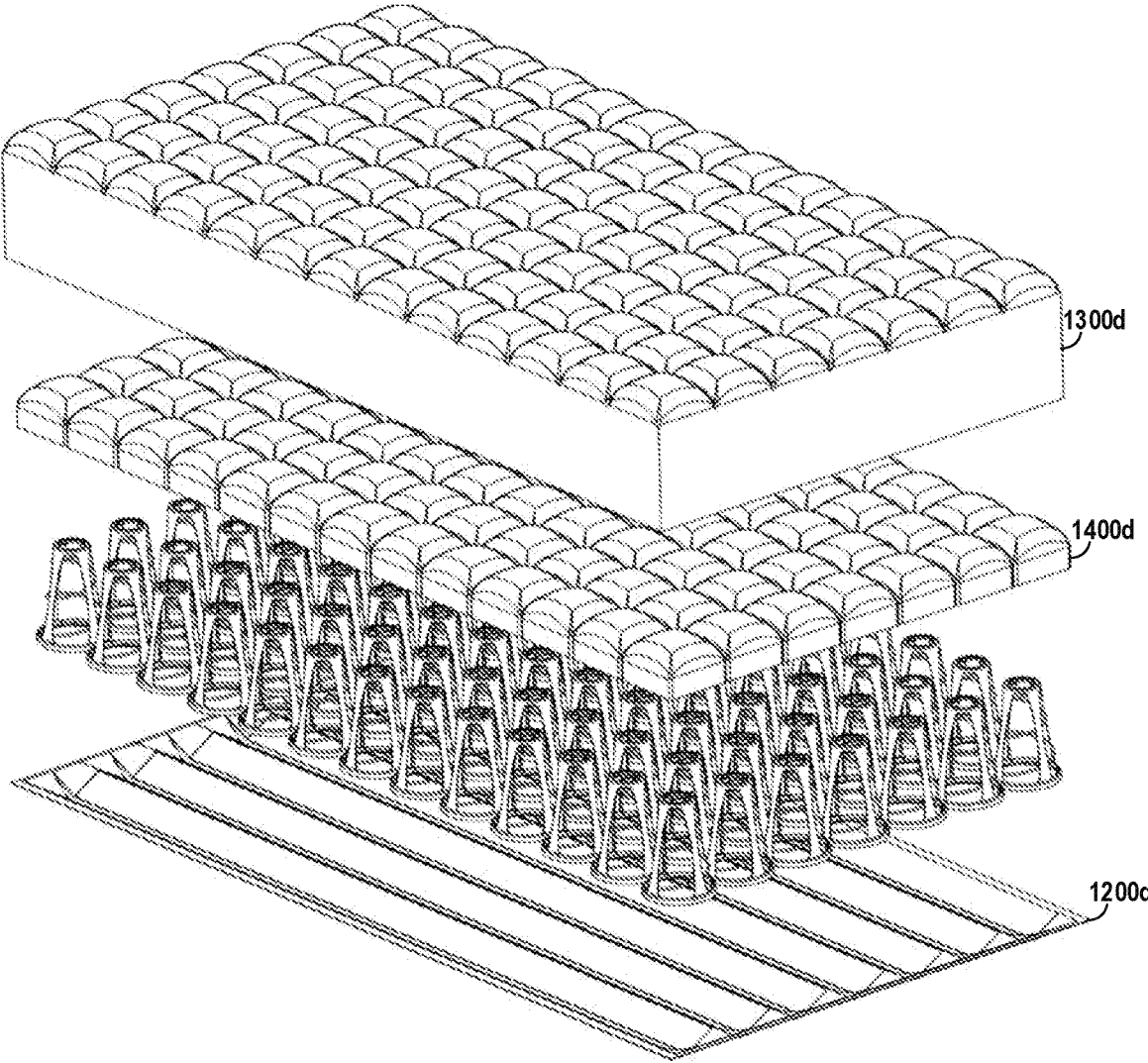

FIG.43A

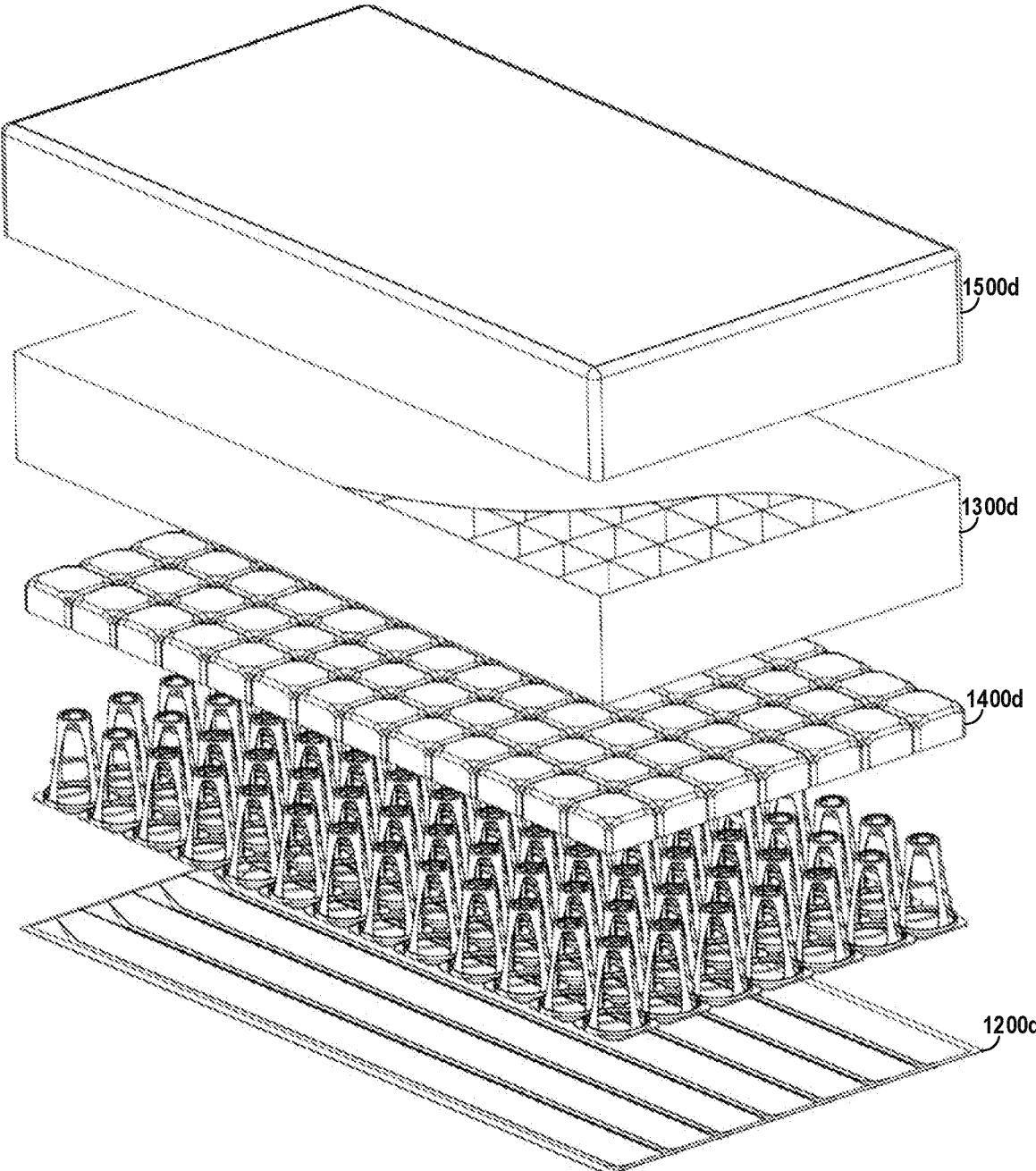

FIG.43B

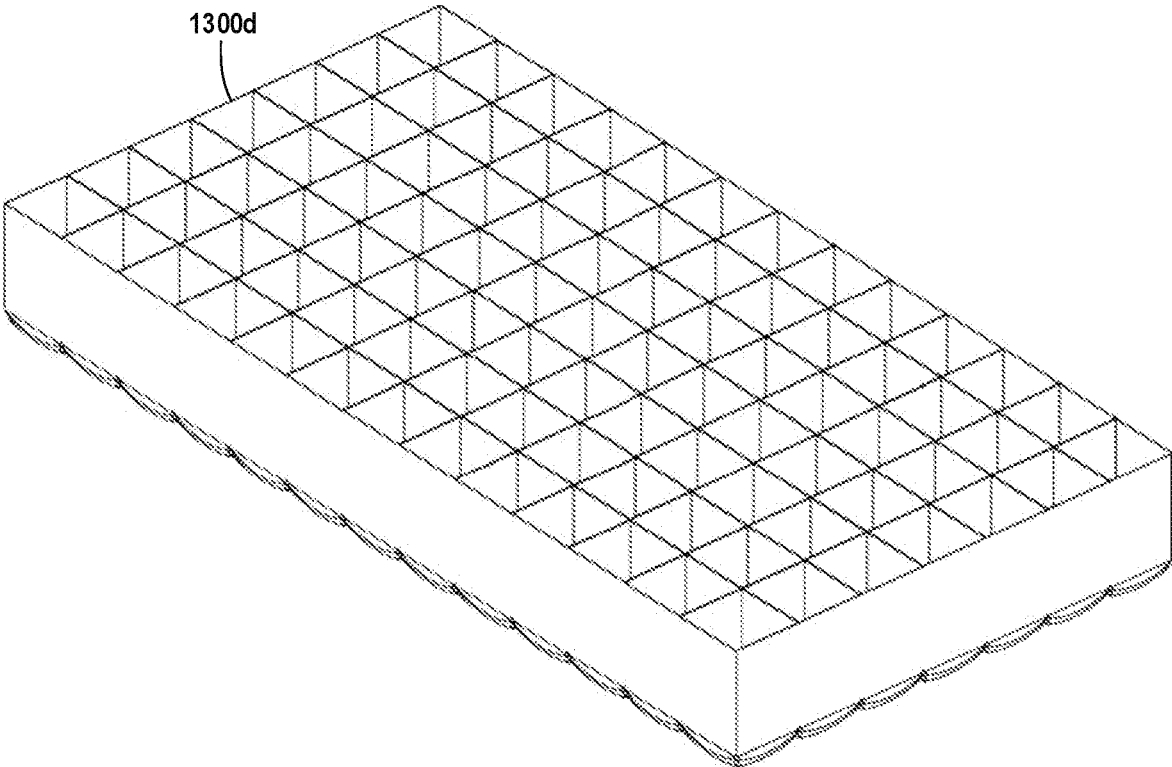

FIG.43C

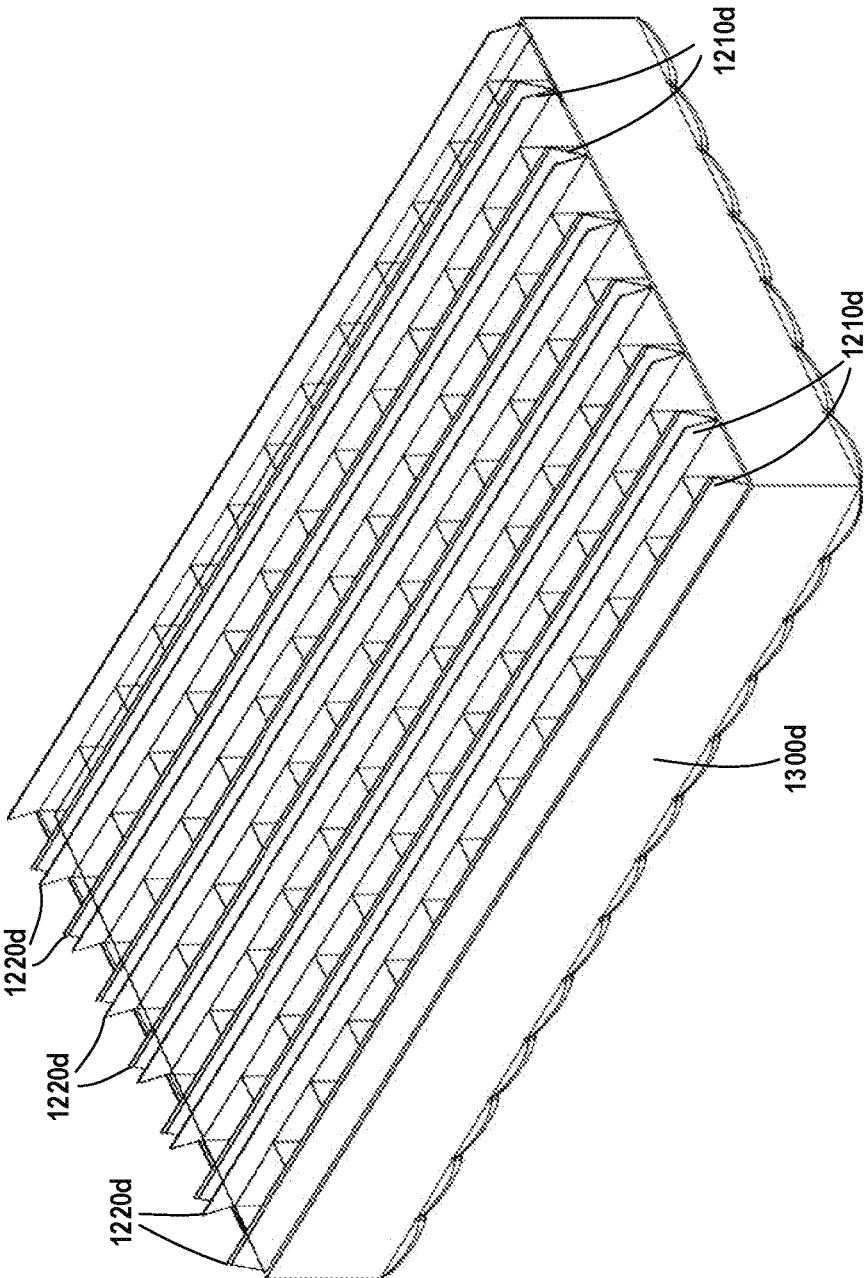

FIG. 43D

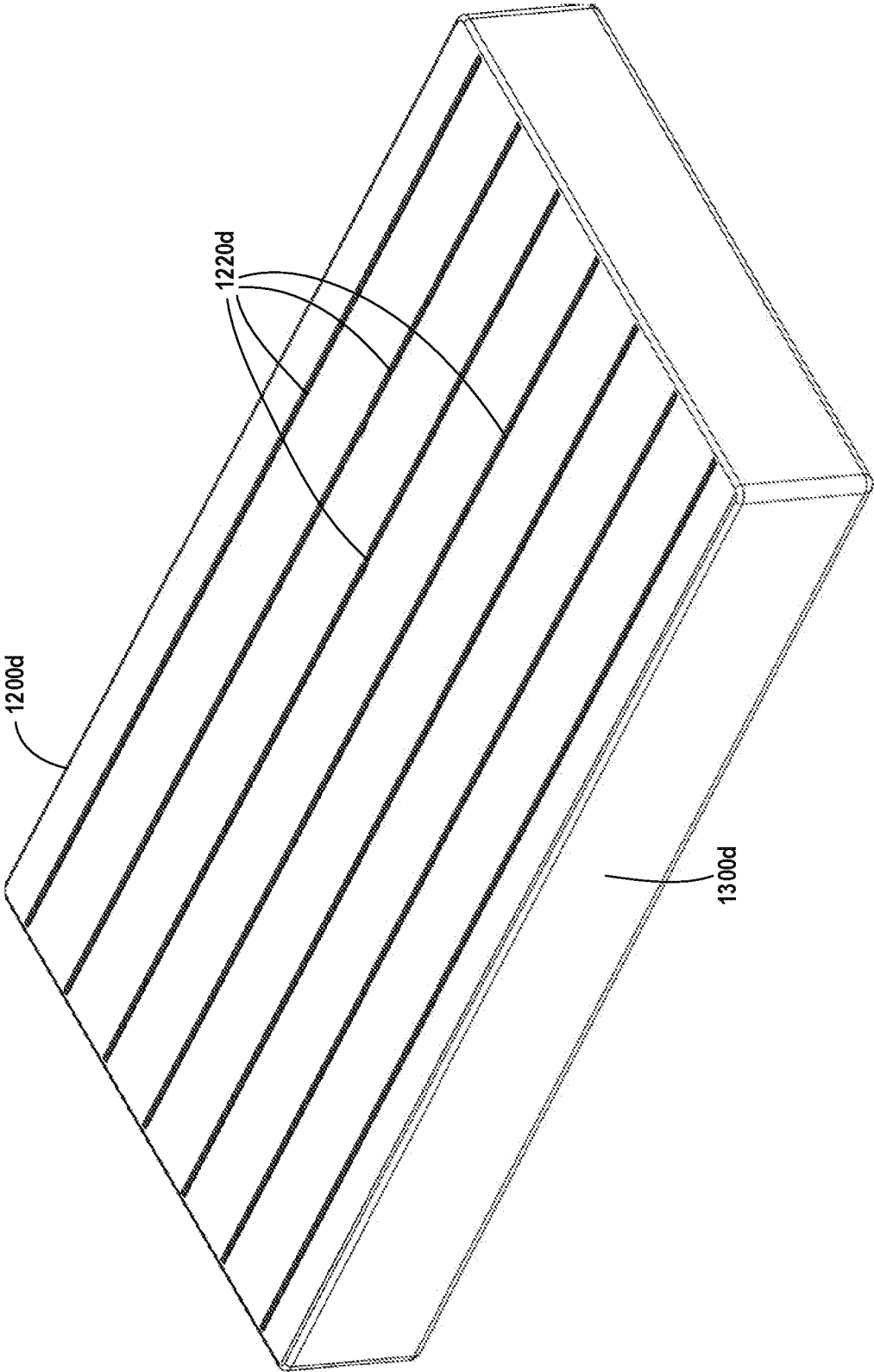

FIG.43E

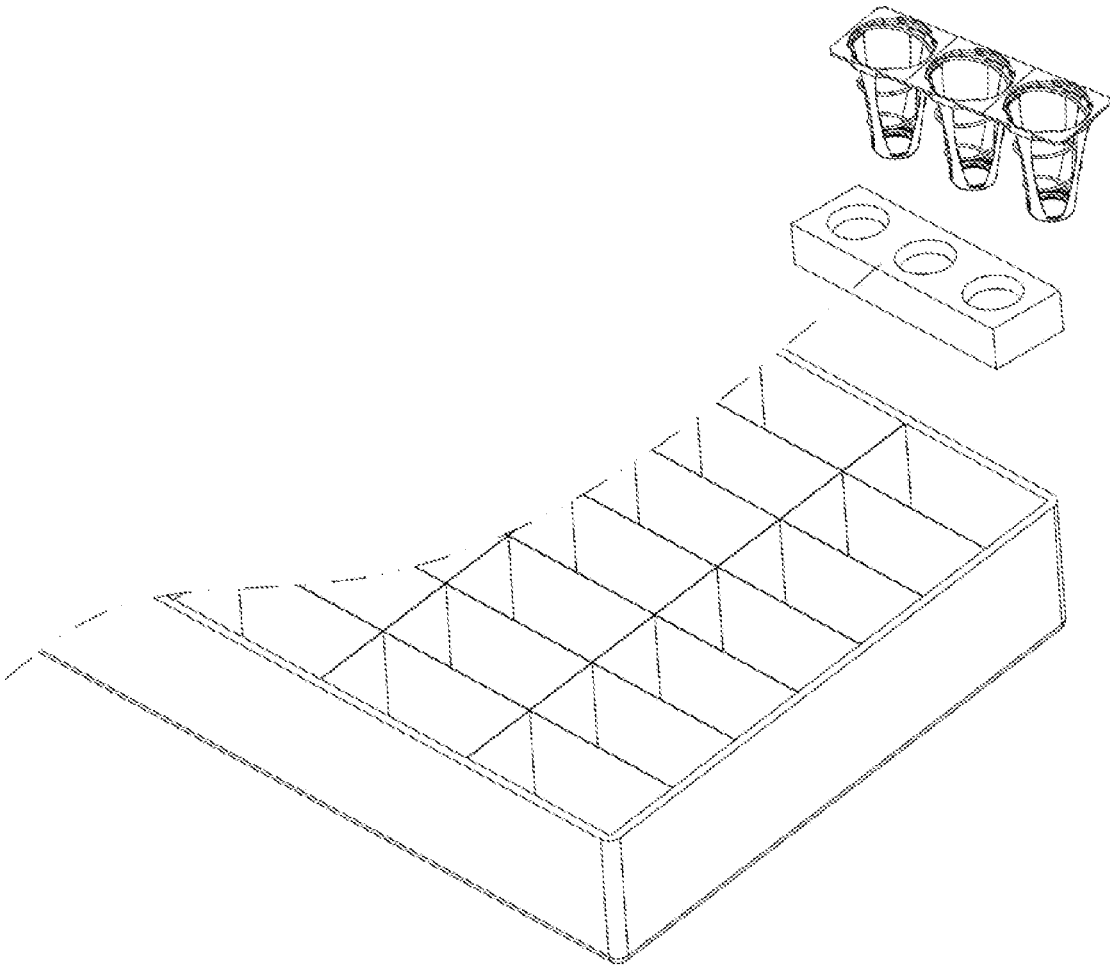

FIG.43F

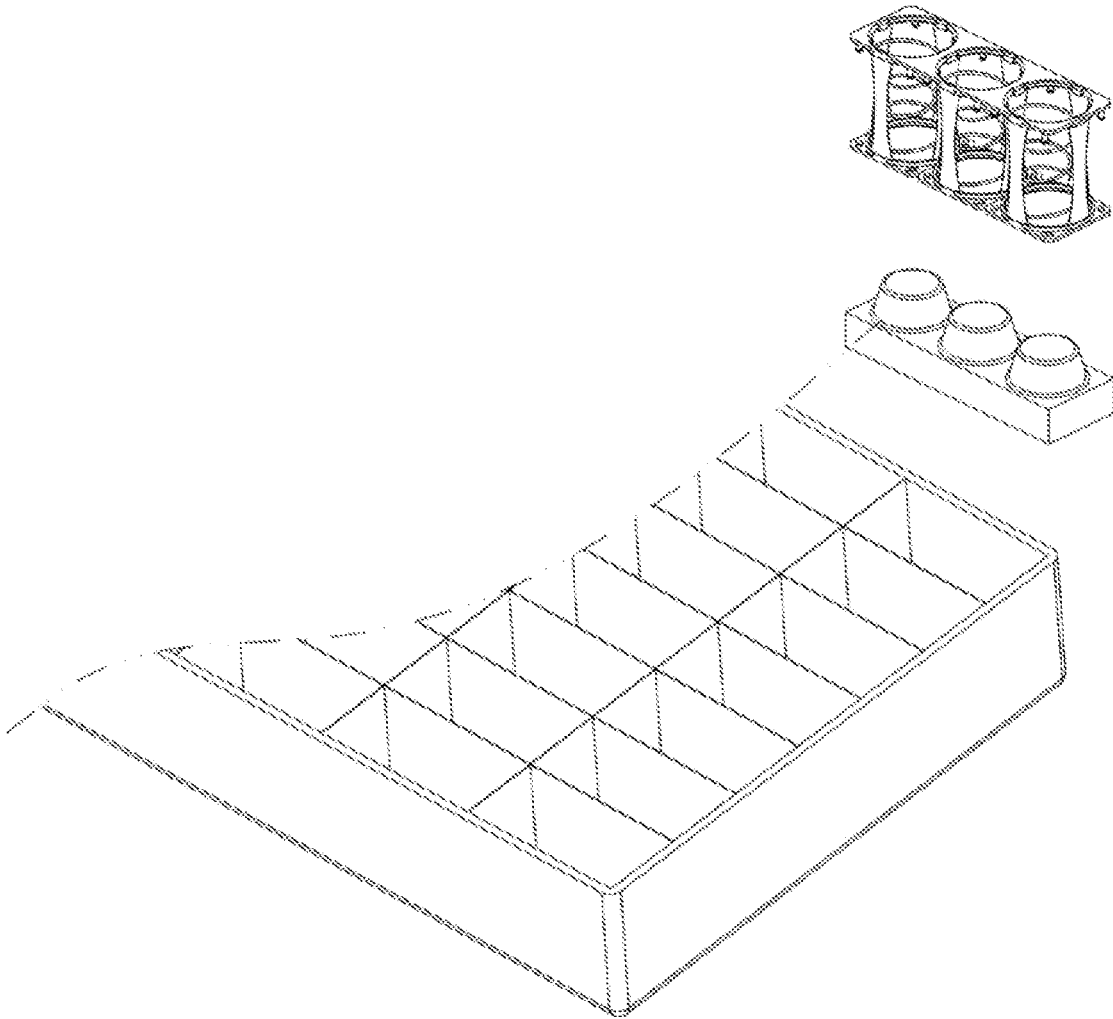

FIG.43G

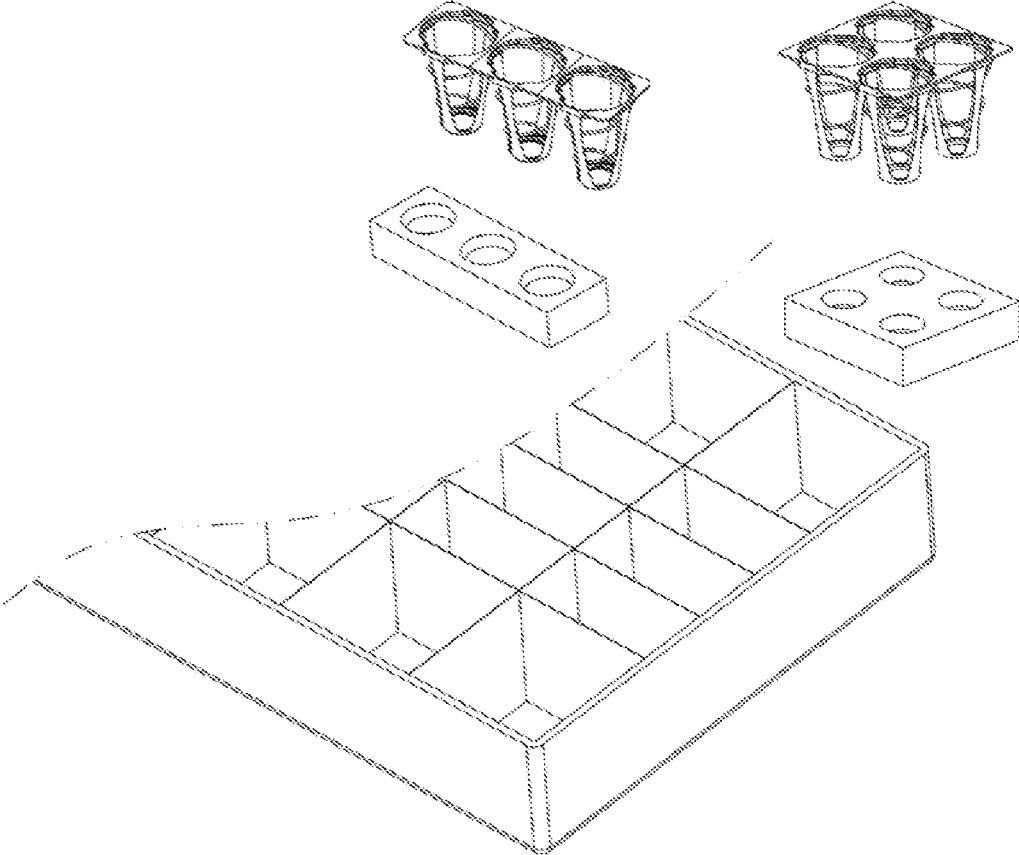

FIG.43H

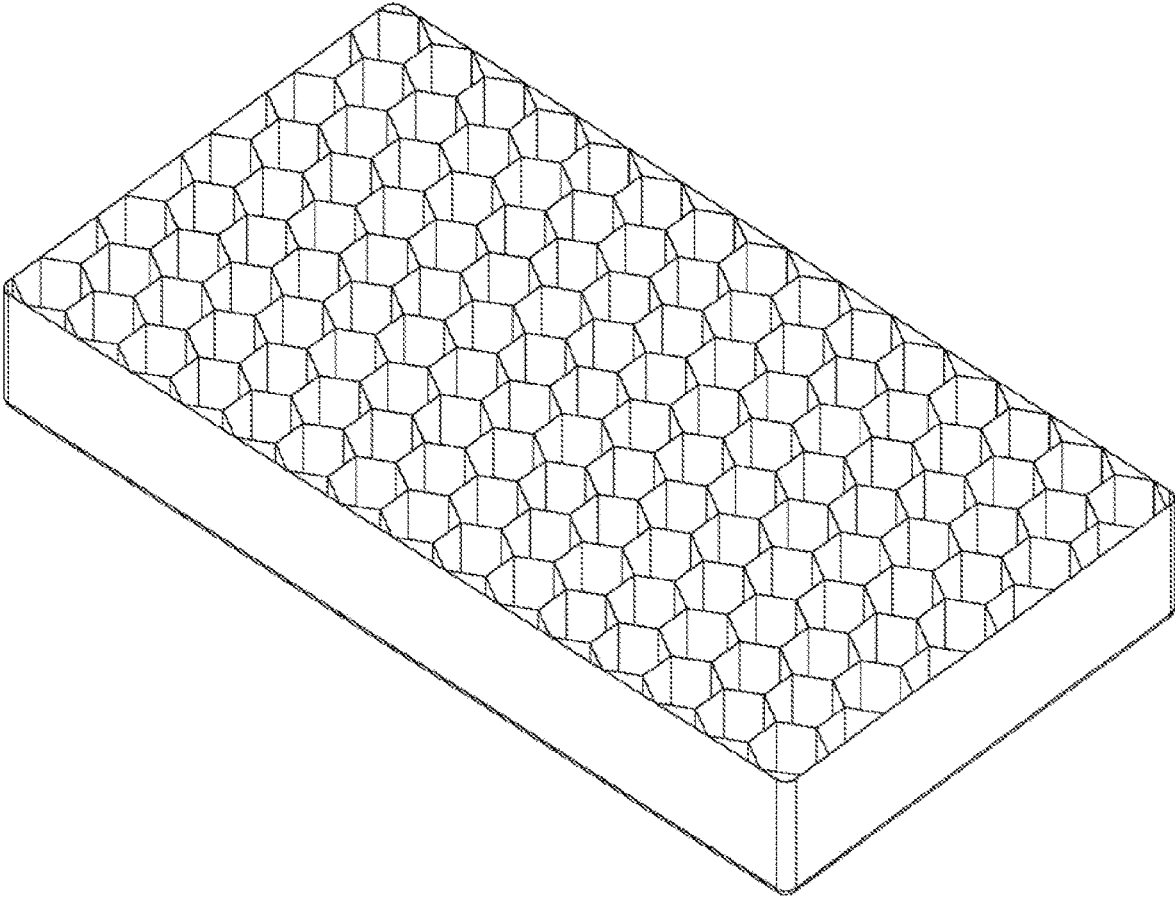

FIG.43I

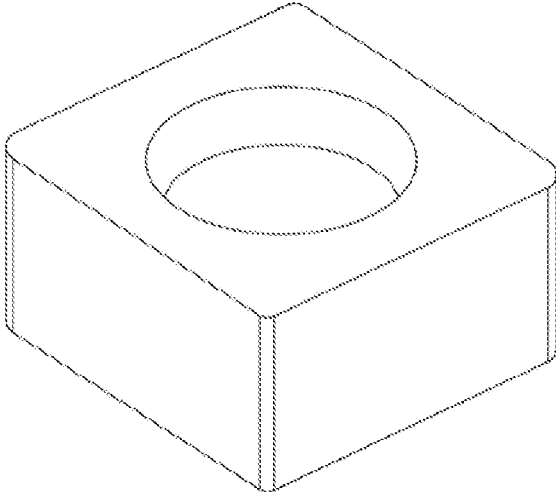

FIG. 44A

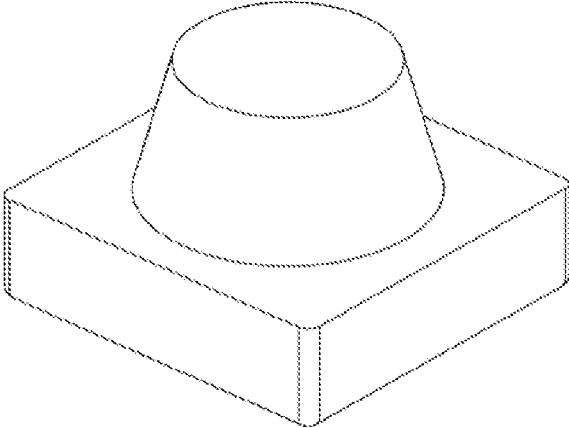

FIG. 44B

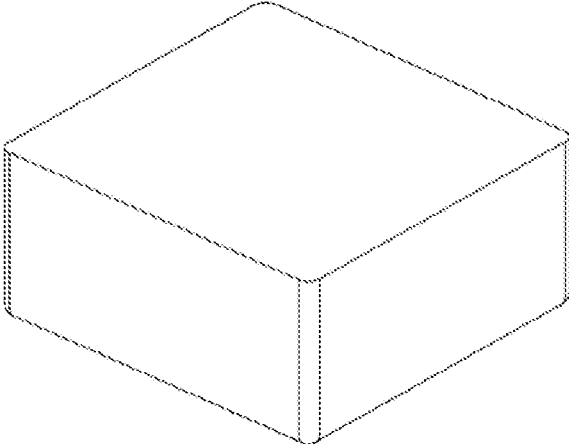

FIG. 44C

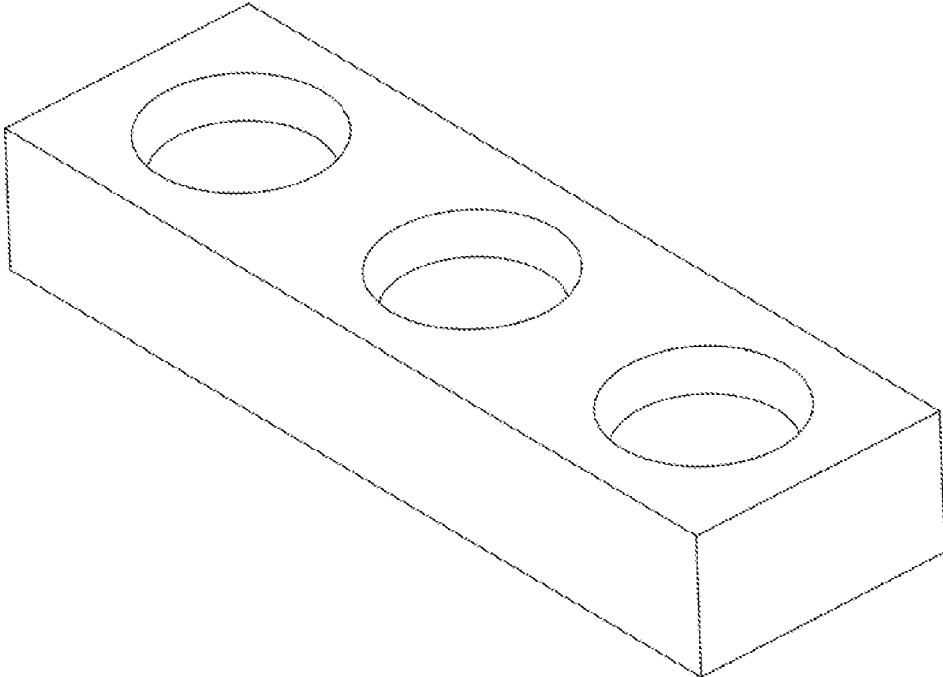

FIG. 44D

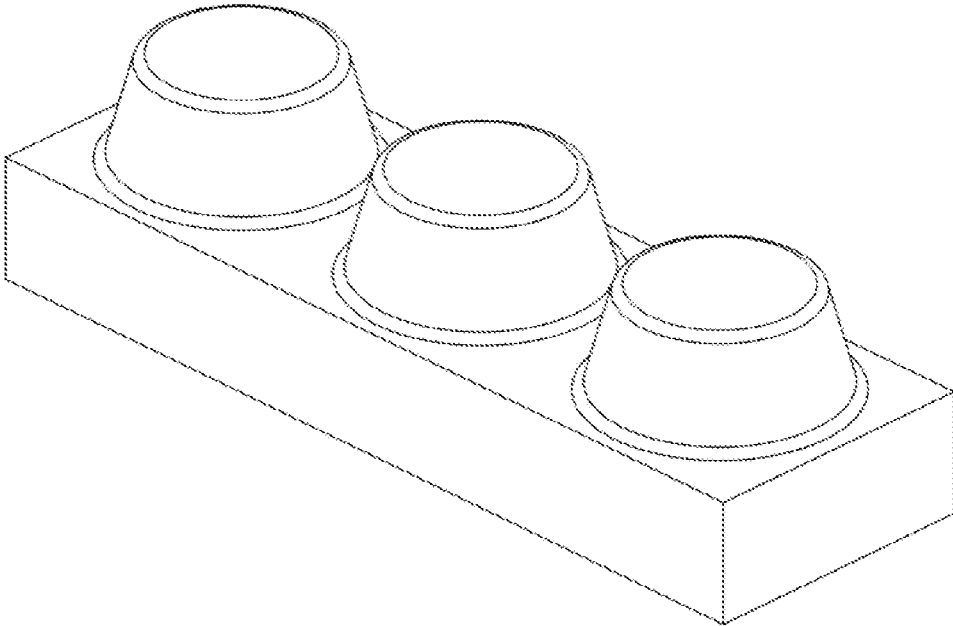

FIG. 44E

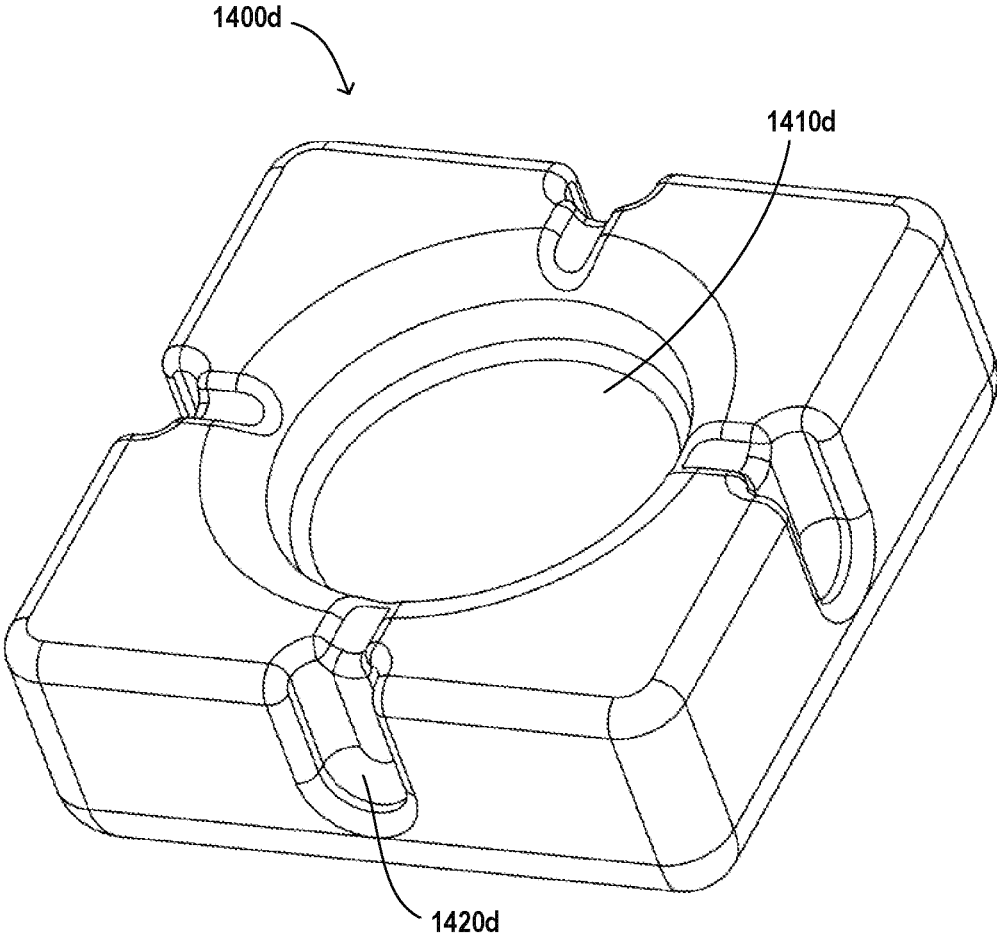

FIG.45A

1400d

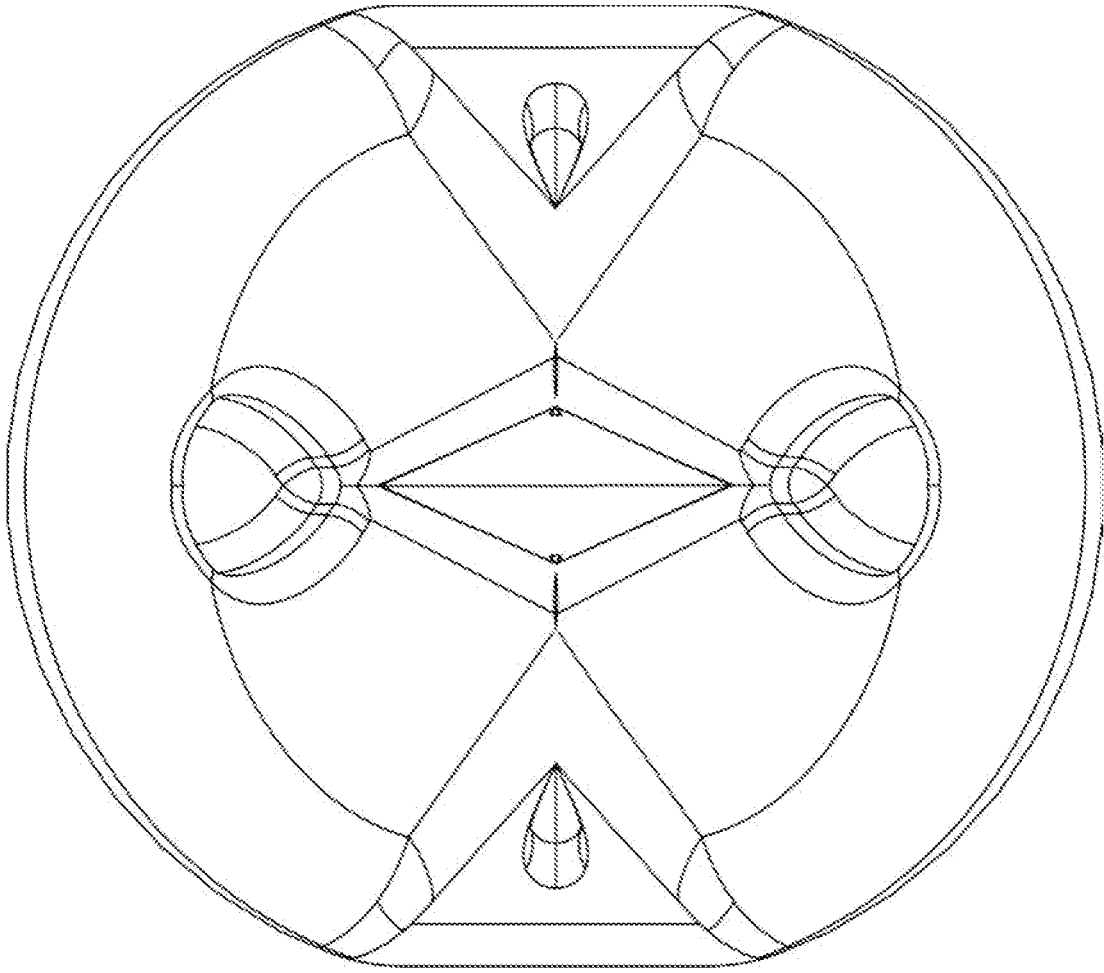

FIG.45B

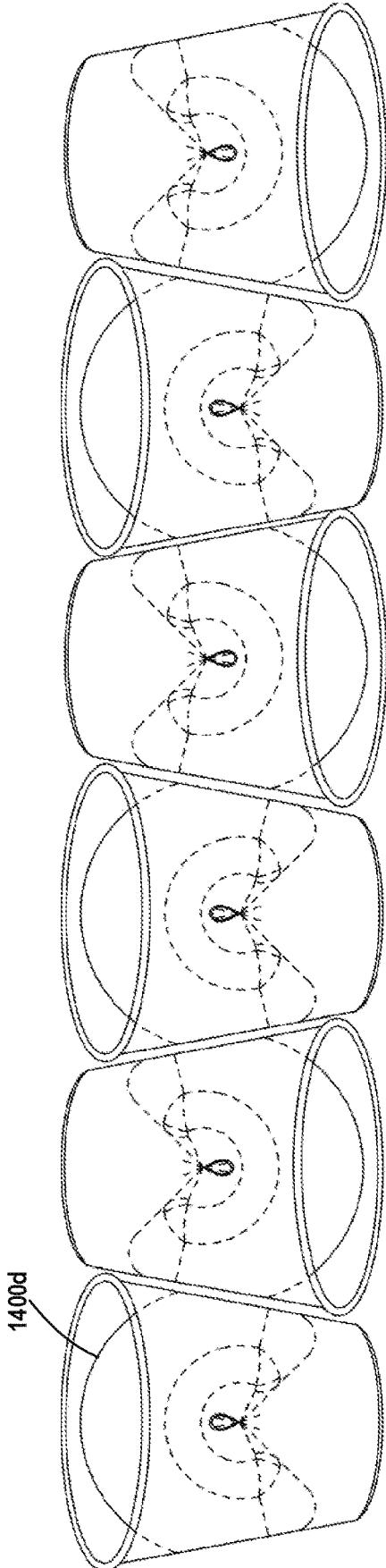

FIG.45C

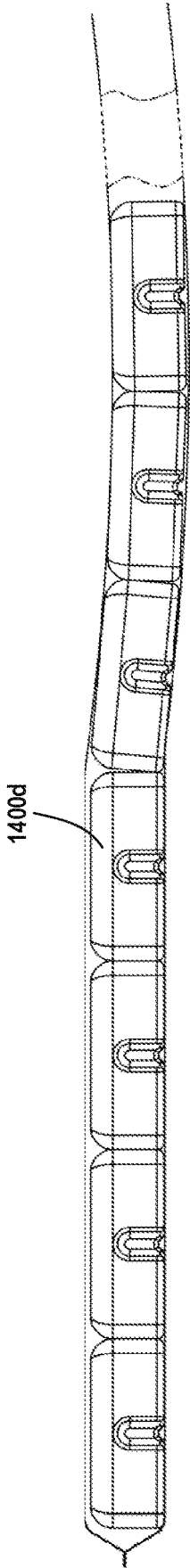

FIG.46A

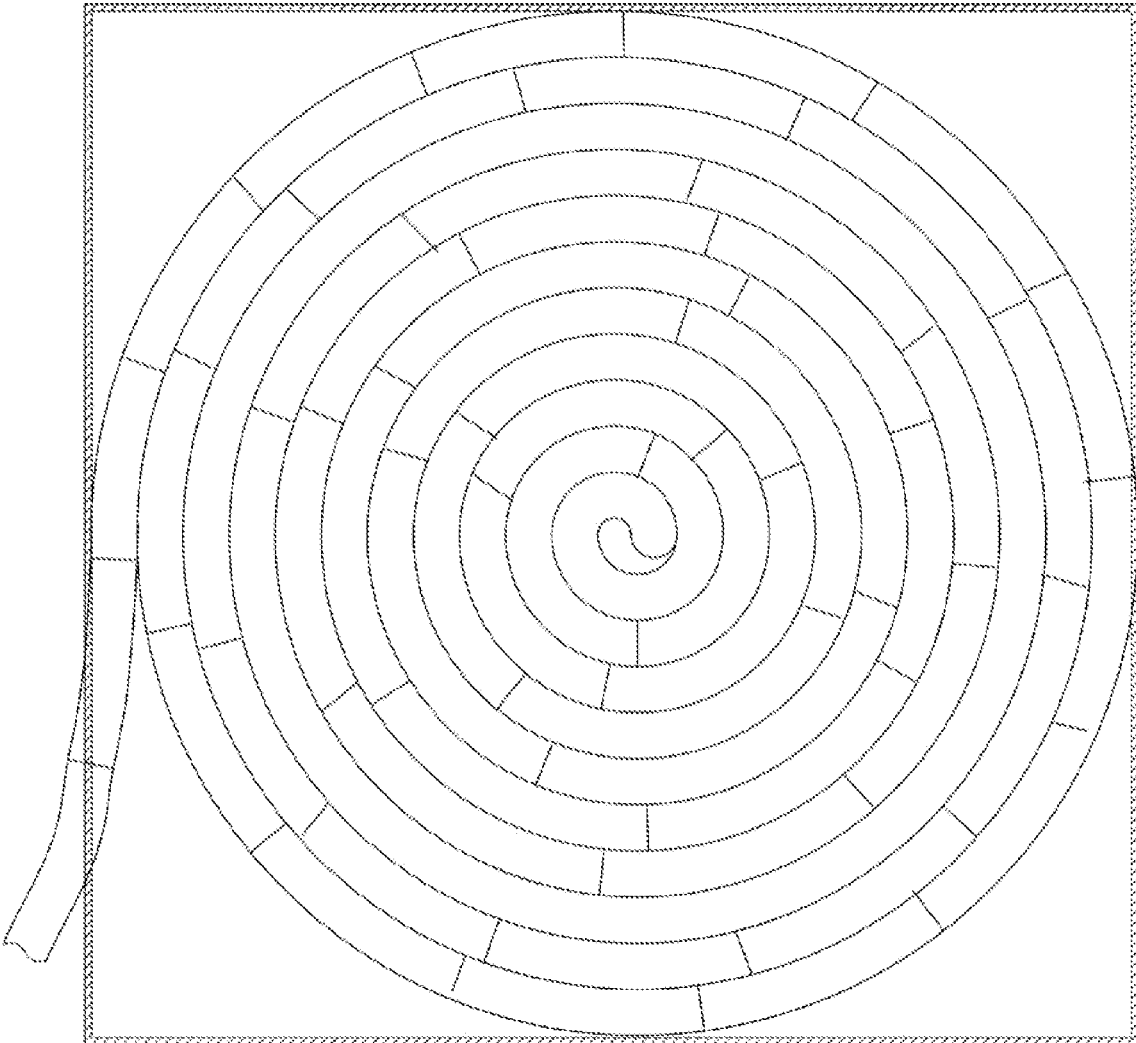

FIG.46B

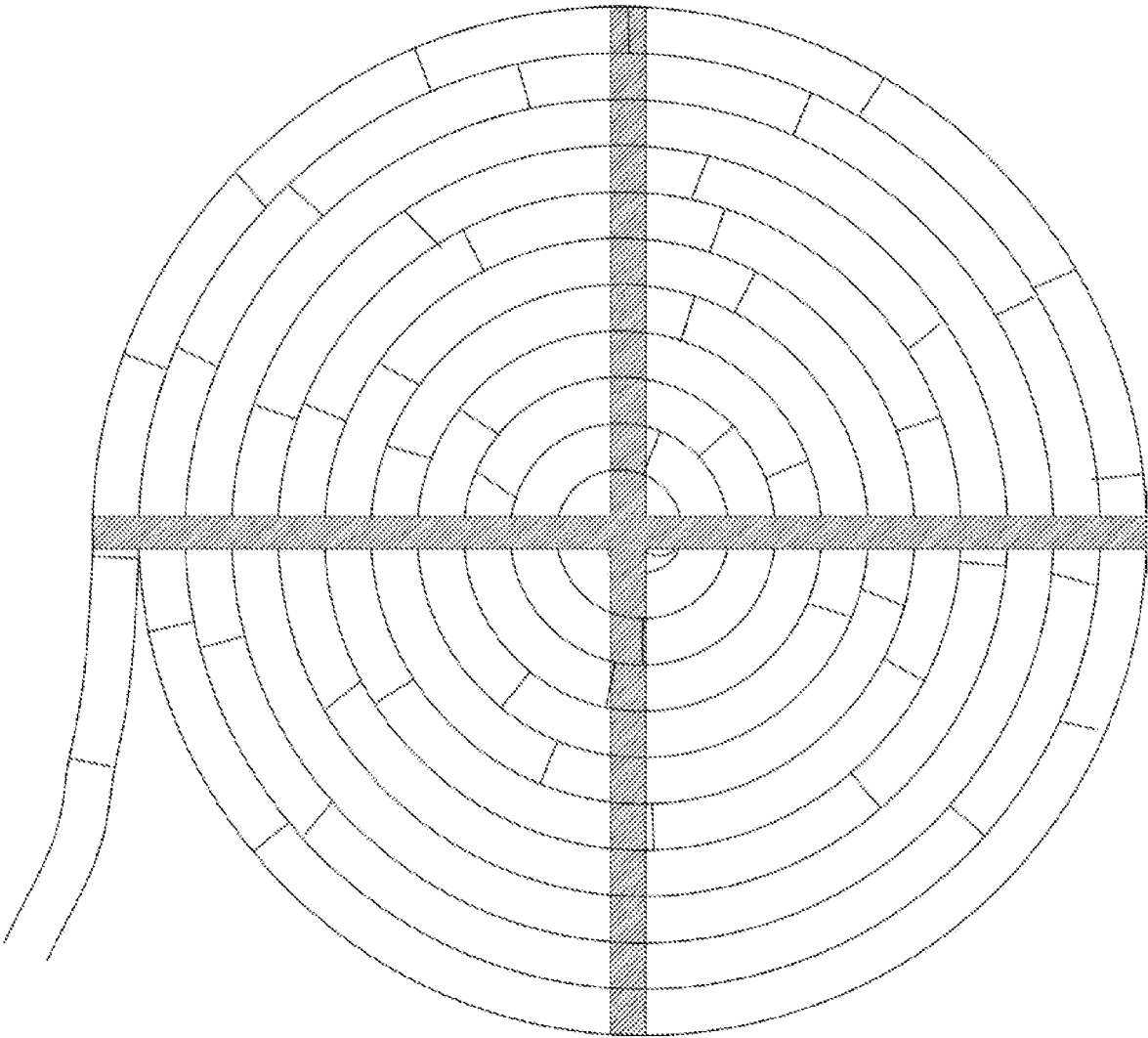

FIG.46C

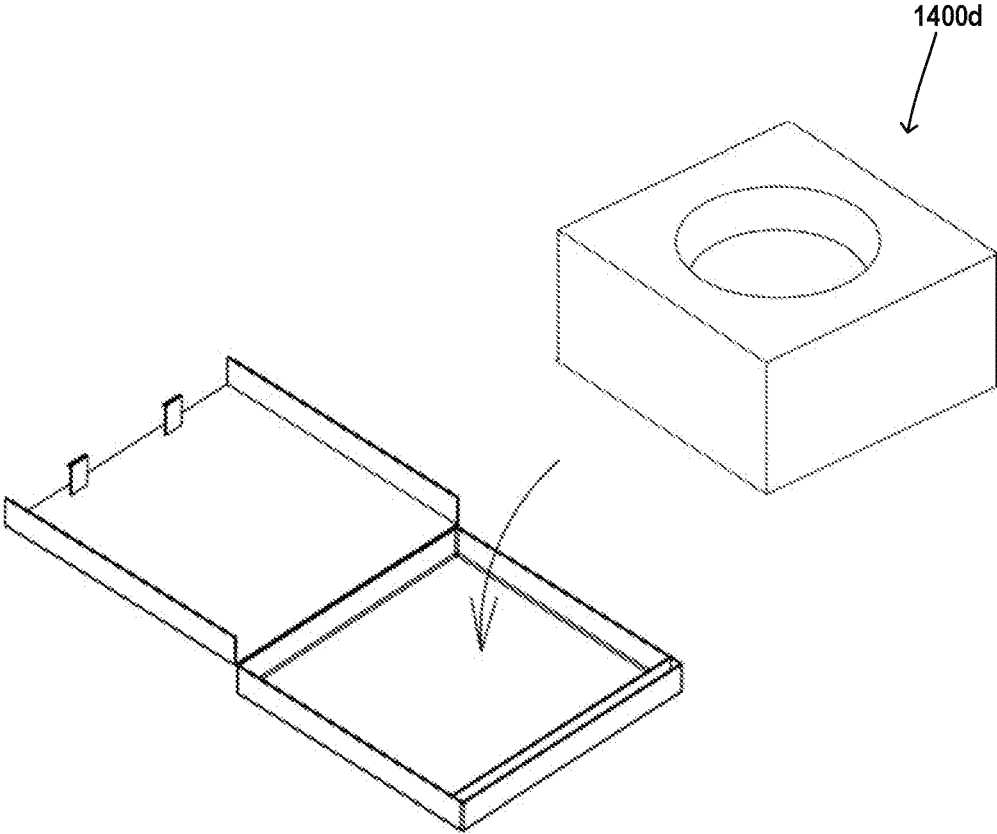

FIG.47A

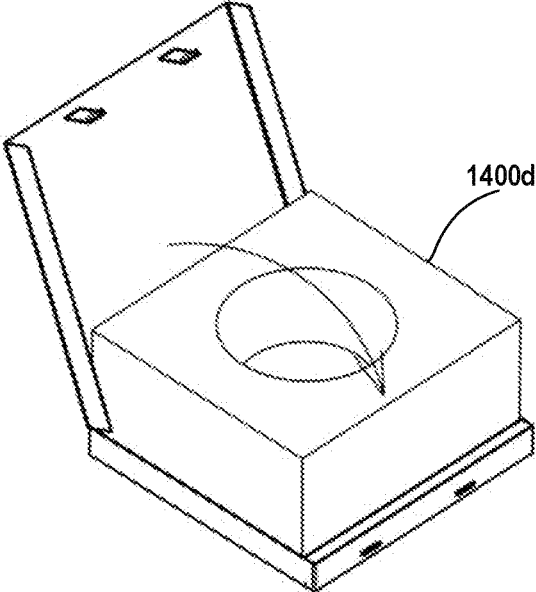

FIG.47B

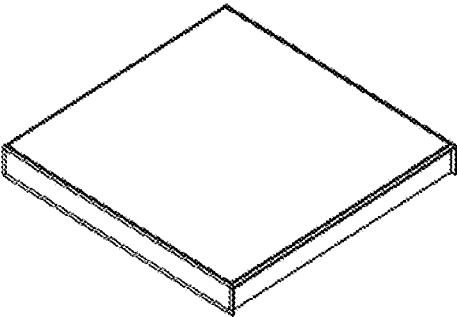

FIG.47C

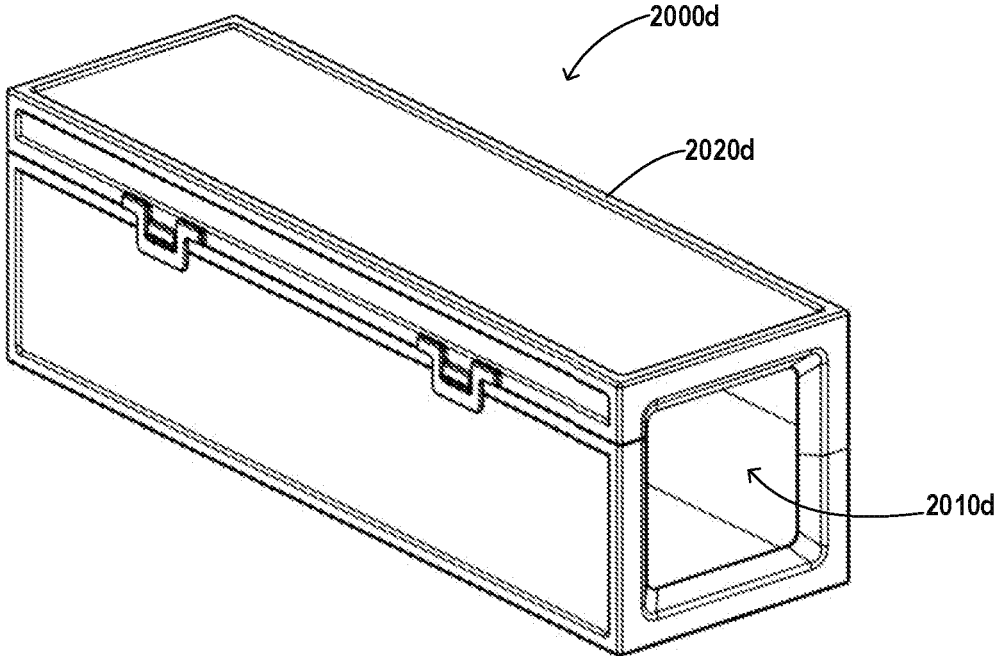

FIG.48A

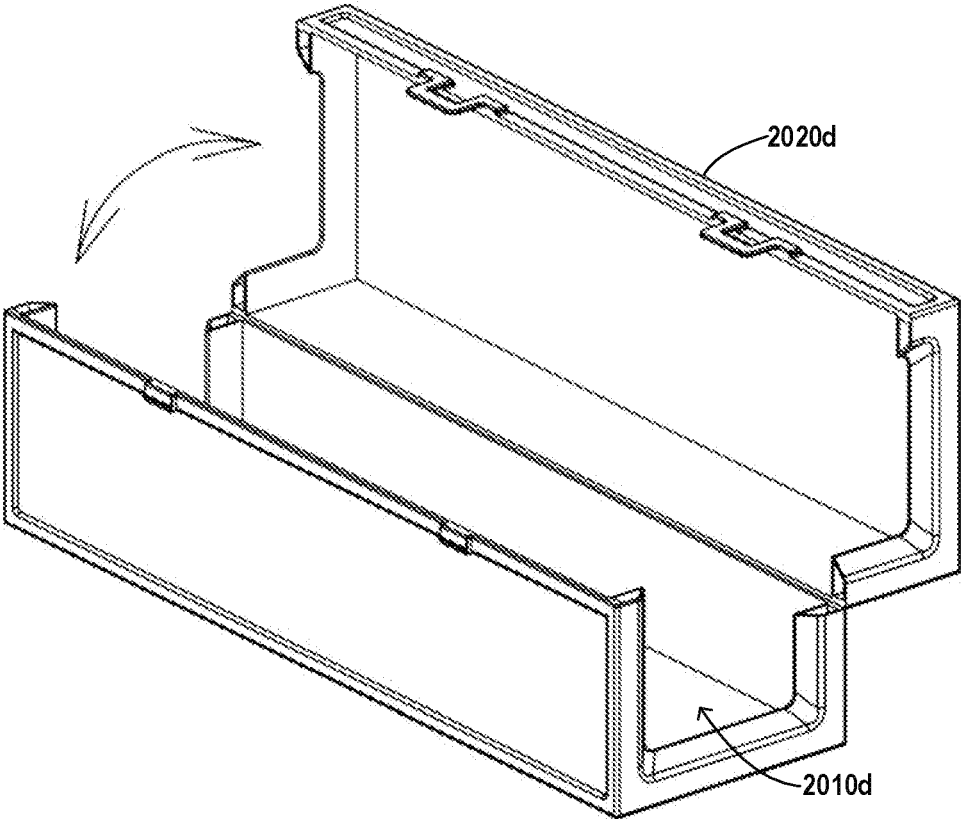

FIG.48B

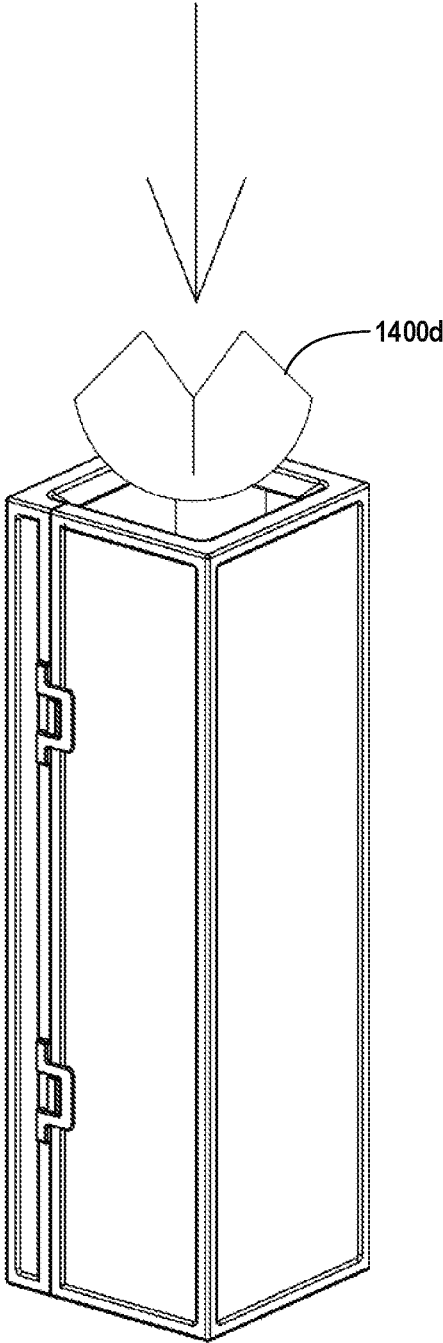

FIG.48C

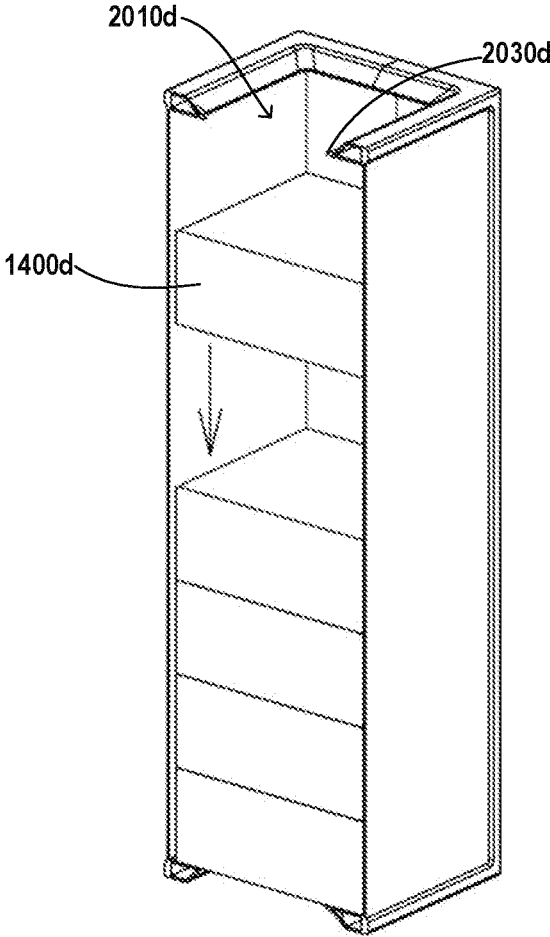

FIG.48D

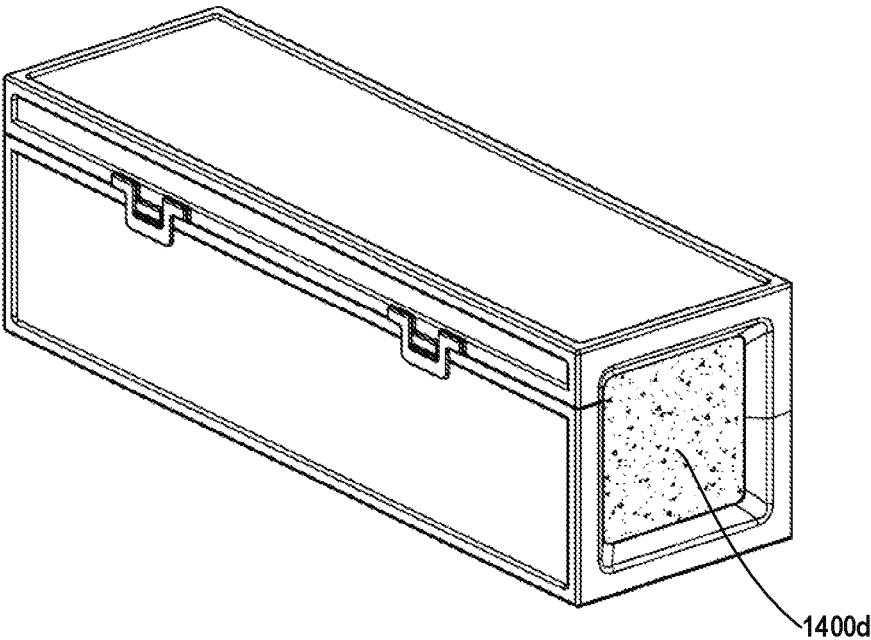

FIG.48E

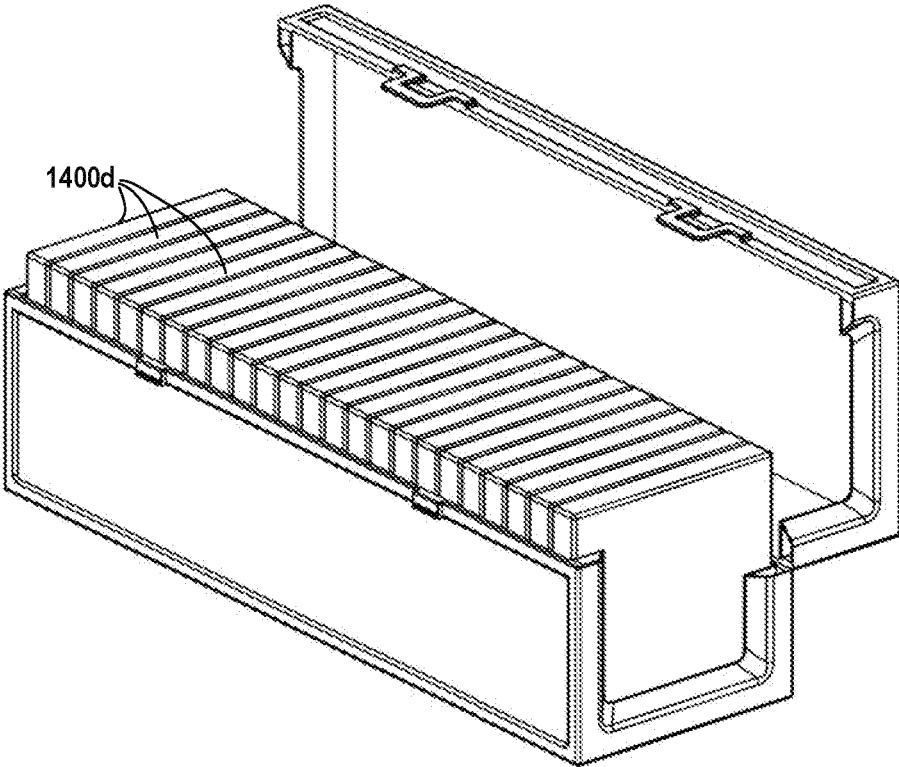

FIG.48F

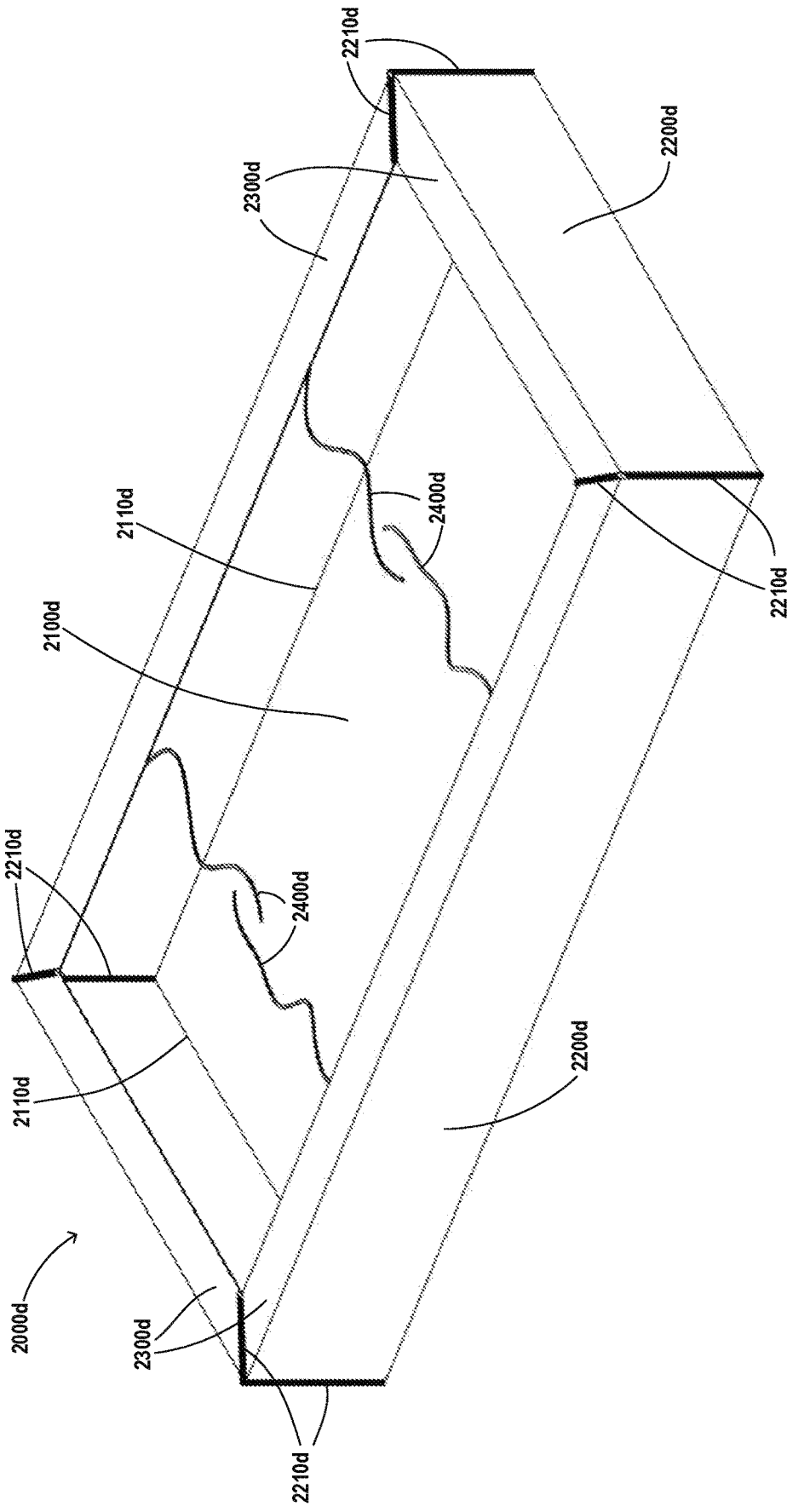

FIG.49A

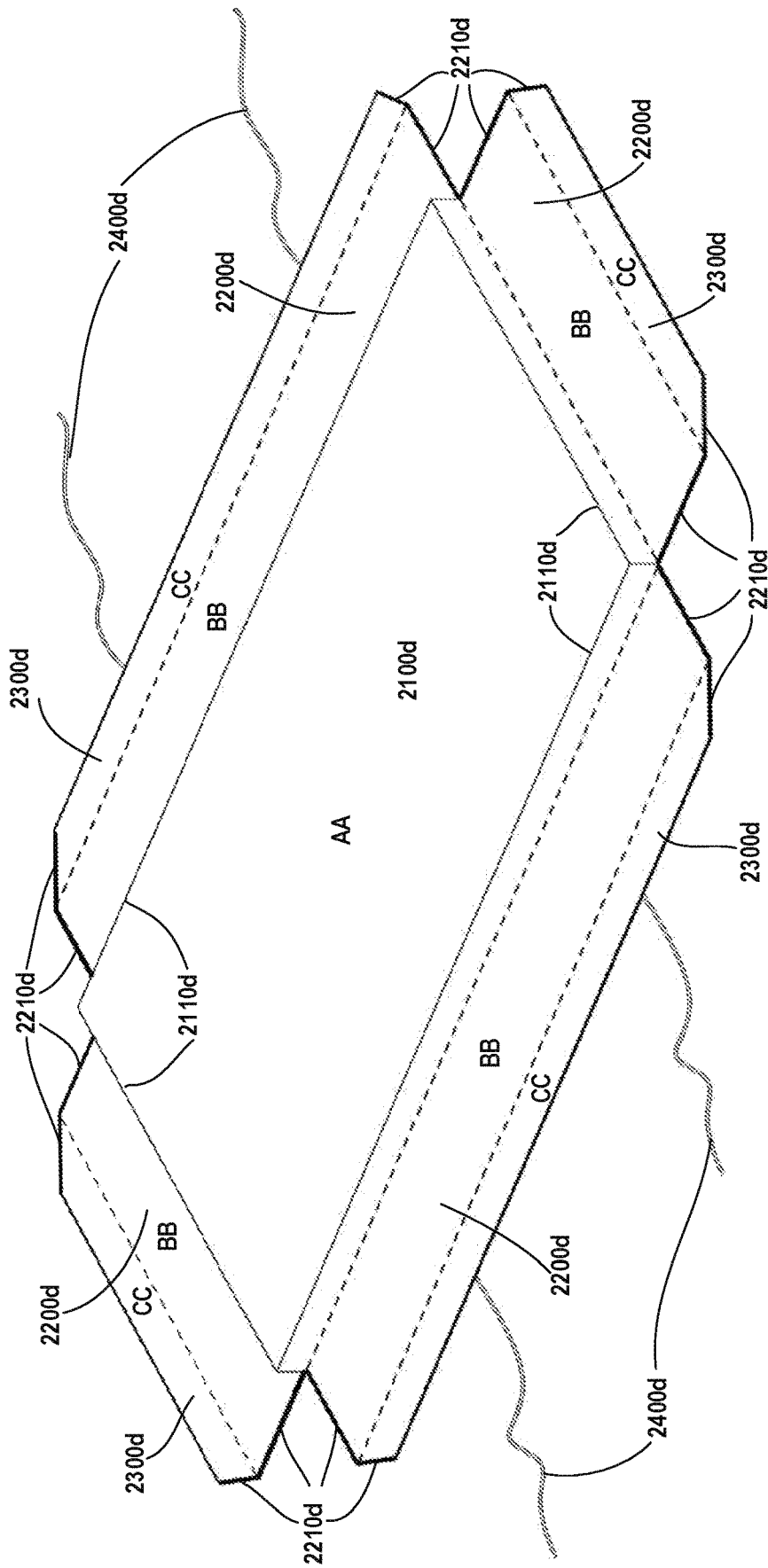

FIG. 49B

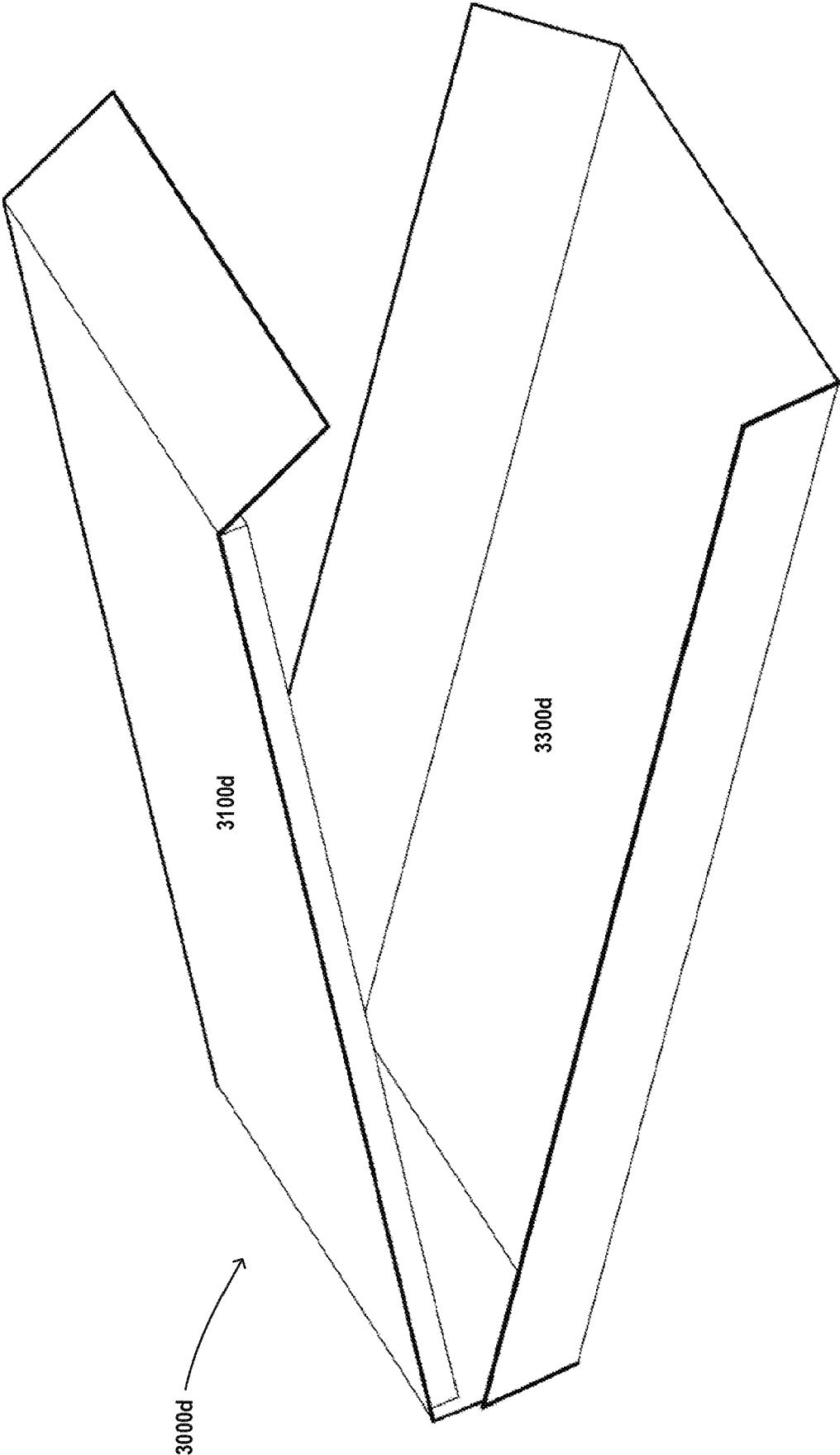

FIG. 50A

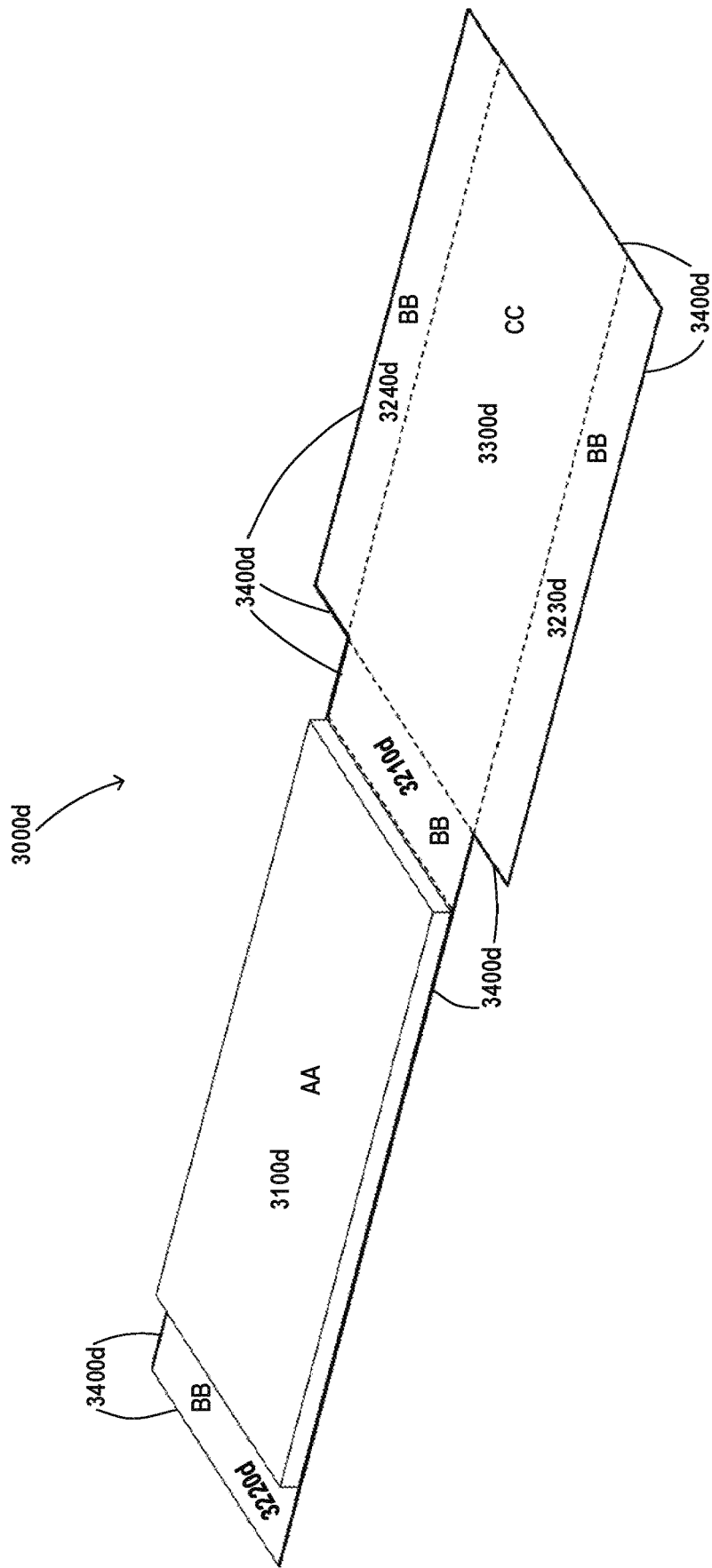

FIG.50B

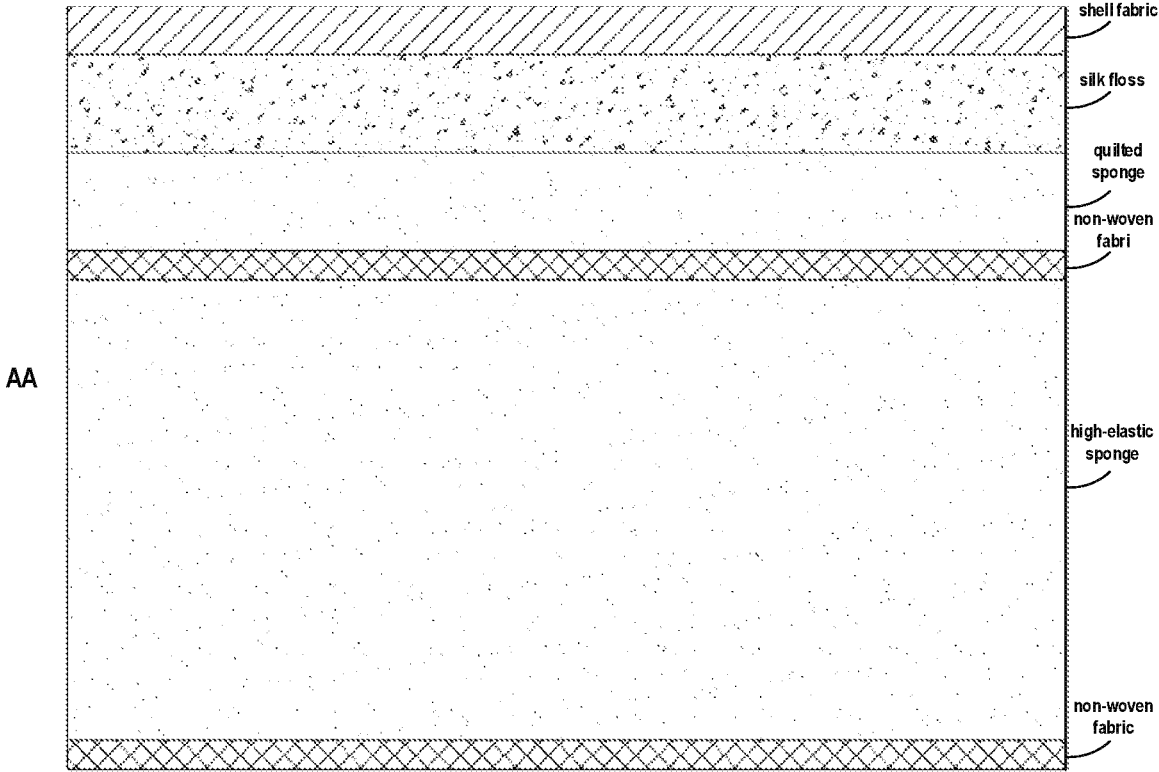

FIG.51A

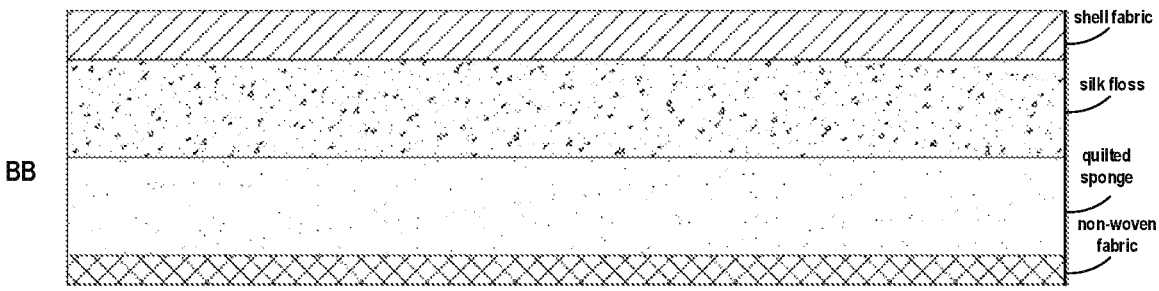

FIG.51B

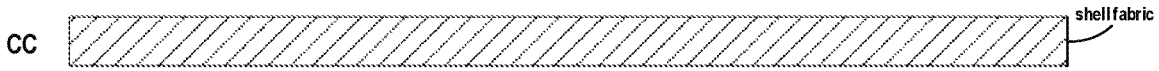

FIG.51C

SPRING MODULE AND SPRING CUSHION FOR FURNITURE

FIELD

[0001] The present disclosure relates to a field of furniture, in particular to a spring module and a spring cushion for furniture.

BACKGROUND

[0002] Large furniture, such as beds, is an essential part of people's life. Most existing large furniture is not easy to disassemble, or is not easy to reassemble after disassembly. However, with the development of the modern life, furniture like beds, in particular, needs to be disassembled and assembled more and more frequently in order to meet the needs of people's migration and outdoor recreation. During the process of migration, it is very difficult to disassemble and assemble beds, thereby the still useable beds are sometimes discarded for reducing the burden of migration.

[0003] A bed is usually composed of a bedstead, a spring cushion and an outer cover. Existing spring cushions are usually integrated, non-disassemble cushions formed by springs and a plurality of superimposed layers. The integral cushions are large in size, thus not easy to disassemble and store.

[0004] Existing independent bagged spring bed mattresses are designed to avoid mutual interference between two or more people lying in bed at the same time (for example, in the case of relatively large weight difference between individuals, one of them will inevitably affect other ones when turning over or moving). In such type of bed mattress, each spring is individually packaged in a bag or a sleeve made of non-woven fabrics or other materials. The bags are arranged in a pattern, and then an outer side of the arranged bag set is covered by a whole piece of foam rubber through adhesion, bonding, etc., so as to form a furniture cushion or a desired spring cushion in the form of a furniture cushion. However, the independent bagged spring bed mattress is still an integral product, which is non-disassemble and not easy to transport. In addition, in the independent bagged spring bed mattress, non-woven fabrics used for covering the bagged springs are adhered to each other, so when the bed mattress is squeezed, a plurality of bagged springs cannot move up and down completely independently, thus affecting the comfort of the bed mattress.

[0005] In addition, existing bed mattresses also have the disadvantage of being difficult to clean. For a typical bed mattress, generally only the bed cover can be removed, while the sponge part cannot be removed, thus not easy to clean. Even though latex may have a certain anti-mite effect, the sponge part which is difficult to clean will bring great health risks since a bed mattress may usually be used for several years.

[0006] Therefore, there is a need for an improved spring cushion, which can be readily disassembled, moved and reassembled, as well as stored in a compact space, and is easy to clean with better comfort.

SUMMARY

[0007] In view of the foregoing problems in the prior art, the present disclosure provides a spring module for a spring cushion of furniture, and a spring cushion with the same. The spring module of the present disclosure has at least

following advantages: simple structure, easy to assemble and form a spring cushion together with a sponge pad, etc., the spring cushion thus formed is easy to disassemble, and the disassembled spring modules are able to be compressed or stacked and nested one another, which may greatly save storage and transportation space; since the spring module has a flexible connecting part positioned outside a spring, the spring in the spring module is not easy to be wound together with springs or other components in adjacent spring modules, no matter in the state of being assembled into spring cushions or in the state of being stacked and nested one another. Compared with a single spring, since the spring module may have a base, its stress area is larger and more stable, thereby the spring cushion is more stable in use; an initial pressure of the spring in the spring module can be predetermined as desired, so that the spring module has a desired stiffness, furthermore, spring modules with different stiffness can be arranged at different positions of the spring cushion as desired; the spring modules in the spring cushion can realize compressing and releasing motions that are truly independent of each other; enabling the spring cushion of the present disclosure to have a better comfort compared with the existing bagged spring bed mattresses; the sponge part (sponge block and/or sponge pad) in the spring cushion is detachable, which is easy to clean. The spring cushion of the present disclosure can be used for furniture having spring cushions, such as, including but not limited to bed mattresses, sofas, soft pack benches, etc.

[0008] In one aspect, the present disclosure provides a spring module for making a spring cushion of furniture, the spring module comprising: a spring module for making a spring cushion of furniture, the spring module comprising: a conical spring; and a spring bracket, configured to accommodate the conical spring therein. The spring bracket comprising: a base which is square, the shape having a spring fixing part for arranging one end of the conical spring; an end cover arranged opposite to the base; and a plurality of flexible straps, two ends of each flexible strap in the plurality of flexible straps being fixedly connected to the base and the end cover respectively, wherein, when the one end of the conical spring is arranged on the spring fixing part, the other end of the conical spring abuts against the end cover, and the flexible straps are positioned outside the conical spring, and wherein, the spring module further comprises locking structures arranged on four sides of the base, the locking structures are configured to match with the locking structures of another adjacently arranged spring module, thus limiting relative movement between adjacently arranged spring modules.

[0009] According to a preferred embodiment, the locking structures comprise: convex parts, the convex parts extending towards outside of the base in directions perpendicular to corresponding sides of the base; and concave parts, the concave parts extending towards inside of the base in directions perpendicular to corresponding sides of the base; wherein, the convex parts and the concave parts are alternately arranged on the sides of the base, and the convex parts and the concave parts are adapted in shape with each other, such that the convex parts and the concave parts of one spring module are able to respectively insert into and receive corresponding concave parts and convex parts of another adjacently arranged spring module in a direction perpendicular to a plane where the base is located, so as to limit the relative movement of the adjacently arranged spring mod-

ules in the plane where the base is located. The beneficial technical effect of the preferred embodiment is at least that, adjacent spring modules can be coupled together in a plugging manner via the locking structures, and the coupling mode is simple and not easy to release from each other.

[0010] According to a preferred embodiment, the convex part has a neck, and a head positioned at an end of the neck and wider than the neck; the concave part has an opening part, and an enlarged concave part which is positioned inside the opening part and wider than the opening part, and shapes of the opening part and the enlarged concave part are respectively adapted with the neck and the head of the convex part, such that the convex parts and the concave parts of one spring module are able to respectively insert into and receive the corresponding concave parts and convex parts of another adjacently arranged spring module in a direction perpendicular to a surface where the base is located. The beneficial technical effect of the preferred embodiment is at least that, adjacent spring modules can be coupled together in a plugging manner along a vertical direction via the locking structures, constraining the relative movement between the adjacent spring modules.

[0011] According to a preferred embodiment, each convex part further comprises:

[0012] a slider configured to slide outward and inward in the convex part along a horizontal direction of the base perpendicular to corresponding sides; an outer side of the slider being provided with a tongue part;

[0013] an elastic member, wherein the elastic member pass through the slider with one end of which fixed on the base, and the other end of the elastic member is able to move between a first limiting member and a second limiting member disposed on the base, and the slider is in a retracted position as the other end of the elastic member moving to a position where it comes into contact with the first limiting member; and the slider is in an extending position as the other end of the elastic member moving to a position where it comes into contact with the second limiting member;

[0014] wherein, each concave part is provided with a groove for accommodating the tongue part of the slider in the extending position, so as to limit the relative movement in a vertical direction between the adjacently arranged spring modules. The beneficial technical effect of the preferred embodiment is at least that, accidental release of the spring modules coupled together can be prevented.

[0015] According to a preferred embodiment, edges of the concave part located on upper and lower surfaces of the base are further formed with guiding inclined surfaces for guiding the tongue part into the concave part. The beneficial technical effect of the preferred embodiment is at least that, the spring modules are easy to be assembled together.

[0016] According to a preferred embodiment, the locking structures comprise: convex parts, the convex parts extending towards outside of the base in directions perpendicular to corresponding sides of the base; and concave parts, the concave parts extending towards inside of the base in directions perpendicular to corresponding sides of the base; wherein, the convex parts and the concave parts are configured such that the convex parts of one spring module are able to insert into the concave parts of another spring module along a direction parallel to a plane where the base is located. The beneficial technical effect of the preferred

embodiment is at least that, adjacent spring modules can be coupled together in a plugging manner along a horizontal direction via the locking structures, constraining the relative movement between the adjacent spring modules.

[0017] According to a preferred embodiment, the convex parts and the concave parts are substantially triangular. The beneficial technical effect of the preferred embodiment is at least that, the triangular structure can play a role of guiding, thus the spring modules being easy to be assembled together.

[0018] According to a preferred embodiment, an upper surface and/or a lower surface of the convex part are provided with a boss, and an upper wall and/or a lower wall is provided with a through hole, the boss is configured to be removably received in the through hole of the concave part of another spring module. The beneficial technical effect of the preferred embodiment is at least that, accidental release of the spring modules coupled together can be prevented.

[0019] According to a preferred embodiment, the convex parts and the concave parts are arranged alternately with each other on the sides of the base.

[0020] According to a preferred embodiment, the convex parts and the concave parts are arranged opposite to each other on the sides of the base. The beneficial technical effect of the preferred embodiment is at least that, different assembling modes of the spring modules can be provided.

[0021] According to a preferred embodiment, the conical spring is installed in the spring bracket with a predetermined initial compression force. The beneficial technical effect of the preferred embodiment is at least that, the spring module can have an ideal initial hardness.

[0022] According to a preferred embodiment, four flexible straps spaced apart from each other are evenly distributed around a periphery of the end cover. The beneficial technical effect of the preferred embodiment is at least that, winding between the spring modules can be avoided by means of using a small number of the flexible straps.

[0023] According to a preferred embodiment, an opening is formed at a center of the end cover. The beneficial technical effect of the preferred embodiment is at least that, it is beneficial for saving materials and costs, and when a plurality of the spring modules are nested together, a space between the end cover and the end cover is communicated with an outer space, which is beneficial for nesting and disassembly.

[0024] According to a preferred embodiment, the base and the end cover form a shape of a substantially frustocone, wherein the end cover forms a small end of the frustocone, the base forms a large end of the frustocone, and an opening is formed at a central position of the base, such that the end cover and most or all of the flexible straps of another spring module are able to enter into an interior of the spring module via the opening so as to form a nesting. The beneficial technical effect of the preferred embodiment is at least that, the spring module can maintain a posture more stably and it is beneficial for nesting of a plurality of the spring modules.

[0025] According to a preferred embodiment, a portion of the conical spring is a double-wire spring part. The beneficial technical effect of the preferred embodiment is at least that, the spring module can have an ideal hardness or elastic coefficient.

[0026] According to a preferred embodiment, the double-wire spring part extends from a large-diameter end of the conical spring to about $\frac{2}{3}$ height of the conical spring. The

beneficial technical effect of the preferred embodiment is at least that, the spring module can have an ideal hardness or elastic coefficient.

[0027] In another aspect, the present disclosure further provides a spring cushion used for furniture, the spring cushion comprising: a plurality of the spring modules according to the above-mentioned embodiments; a first sponge pad having a plurality of holes, and each hole is configured to allow a portion of a corresponding spring module to pass through; a second sponge pad laid on one or more of the first sponge pads; and an outer cover covering the second sponge pad, thereby wrapping the spring modules, the first sponge pad and the second sponge pad.

[0028] According to a preferred embodiment, the first sponge pad comprises a plurality of separate parts arranged side by side, each separate part having a different hardness and a different color, respectively. The beneficial technical effect of the preferred embodiment is at least that, different hardness can be provided at different positions of a mattress depending on personal preference or ergonomics, and the parts of sponge pad with different hardness can be easily distinguished.

[0029] According to a preferred embodiment, the spring cushion further comprises a fixing net arranged below the first sponge pad, the fixing net has a plurality of ring parts, each ring part being configured to allow a portion of a corresponding spring module to pass through. The beneficial technical effect of the preferred embodiment is at least that, the integrated net can help to fix positions and postures of the spring modules, making the whole more stable and less likely to be dislocated.

[0030] According to a preferred embodiment, when the fixing net is arranged on the spring modules, a vertical distance between the ring part and a top of the spring module is about $\frac{1}{3}$ of an overall height of the spring module. The beneficial technical effect of the preferred embodiment is at least that, the connection relationship among a plurality of the spring modules will be more stable and not easy to collapse.

[0031] According to a preferred embodiment, the spring cushion further comprises a fixing net assembly, the fixing net assembly comprising: a flexible sheet having a plurality of holes; and a plurality of caps, each cap having a cavity and a flange extending around the cavity; wherein a size of the hole is larger than that of a wall forming the cavity and smaller than that of the flange, such that the wall is able to pass through the hole while the flange engages a flexible sheet portion around the hole, and wherein the flange is fixedly coupled to the flexible sheet portion around the hole by adhesive or ultrasonic welding, and wherein the cavity is configured to receive a top of the spring module. The beneficial technical effect of the preferred embodiment is at least that, the fixing net assembly can help to fix positions and postures of the spring modules, making the whole more stable and less likely to be dislocated.

[0032] According to a preferred embodiment, the spring cushion further comprises a fixing net assembly, the fixing net assembly comprising: a flexible sheet without holes; a plurality of upper caps positioned on one side of the flexible sheet, each upper cap having a first snap feature; and a plurality of lower caps positioned on the other side of the flexible sheet, each lower cap having a second snap feature; wherein the first snap feature of the upper cap is configured to engage together with the second snap feature of the lower

cap and clamp the flexible sheet between the upper cap and the lower cap, and wherein the lower cap is configured to receive a top of the spring module. The beneficial technical effect of the preferred embodiment is at least that, the fixing net assembly can help to fix positions and postures of the spring modules, making the whole more stable and less likely to be dislocated.

[0033] In another aspect, the present disclosure provides a spring cushion for furniture, the spring cushion comprising:

[0034] a plurality of the spring modules according to the above-mentioned embodiments;

[0035] a spring pad laid on the spring modules, the spring pad comprising a first non-woven fabric layer, a second non-woven fabric layer, and a plurality of small cylindrical springs which are tightly arranged between the first non-woven fabric layer and the second non-woven fabric layer, wherein the first non-woven fabric layer and the second non-woven fabric layer are jointed together around each small cylindrical spring so as to form compartments for accommodating the plurality of small cylindrical springs, thereby enabling adjacent small cylindrical springs to be spaced apart from each other;

[0036] an outer cover comprising a quilted sponge layer and covering the spring pad so as to wrap the spring modules and the spring pad.

[0037] According to a preferred embodiment, an elastic coefficient of the small cylindrical spring is smaller than that of the spring in the spring module. The beneficial technical effect of the preferred embodiment is at least that, the spring pad can provide hardness close to the sponge.

[0038] According to a preferred embodiment, the plurality of small cylindrical springs are arranged more tightly than the spring modules. The beneficial technical effect of the preferred embodiment is at least that, the spring pad can provide comfort close to the sponge pad.

[0039] According to a preferred embodiment, the first non-woven fabric layer and the second non-woven fabric layer are jointed together around each small cylindrical spring by adhesive or ultrasonic welding. The beneficial technical effect of the preferred embodiment is at least that, each small cylindrical spring is separated so as to avoid interference with each other.

[0040] According to a preferred embodiment, the spring cushion further comprises a sponge pad arranged between the spring modules and the spring pad, the sponge pad having a plurality of holes, each hole is configured to allow a portion of a corresponding spring module to pass through. The beneficial technical effect of the preferred embodiment is at least that, the sponge pad can not only provide better comfort, but also help to constrain the relative movement between the spring modules.

[0041] In another aspect, the present disclosure provides a spring cushion used for furniture, the spring cushion comprising: a spring pad, the spring pad comprising a first non-woven fabric layer, a second non-woven fabric layer, and a plurality of small cylindrical springs which are tightly arranged between the first non-woven fabric layer and the second non-woven fabric layer, wherein the first non-woven fabric layer and the second non-woven fabric layer are jointed together around each cylindrical spring by adhesive or ultrasonic welding, so as to clamp a plurality of cylindrical springs between the first non-woven fabric layer and the second non-woven fabric layer and separate adjacent

cylindrical springs of the plurality of cylindrical springs from each other; and an outer cover having a quilted sponge layer and wrapping the spring pad.

[0042] It is obvious that the elements or features described in the above single embodiment may be used alone or in combination in other embodiments.

BRIEF DESCRIPTION OF THE DRAWINGS

[0043] The dimensions and proportions in the accompanying drawings do not represent the dimensions and proportions of the actual products. The accompanying drawings are merely illustrative, and some unnecessary elements or features are omitted for clarity.

[0044] FIG. 1A exemplarily shows a perspective view of a spring module according to a preferred embodiment of the present disclosure.

[0045] FIG. 1B exemplarily shows a spring of the spring module in FIG. 1A.

[0046] FIG. 1C exemplarily shows a spring bracket of the spring module in FIG. 1A.

[0047] FIG. 1D exemplarily shows an exploded view of the spring module in FIG. 1A.

[0048] FIG. 1E exemplarily shows a front view of the spring module in FIG. 1A.

[0049] FIG. 1F exemplarily shows a bottom view of the spring module in FIG. 1A.

[0050] FIG. 2 exemplarily shows a perspective view of a mounting rack according to a preferred embodiment of the present disclosure.

[0051] FIG. 3A exemplarily shows a front view of the mounting rack in FIG. 2 in an unfolded state.

[0052] FIG. 3B exemplarily shows a bottom view of the mounting rack in FIG. 2 in an unfolded state.

[0053] FIG. 3C exemplarily shows a side view of the mounting rack in FIG. 2 in a folded state.

[0054] FIG. 3D exemplarily shows a front view of the mounting rack in FIG. 2 in a folded state.

[0055] FIG. 4A exemplarily shows that the spring modules in FIG. 1A are assembled to the mounting rack in FIG. 2.

[0056] FIG. 4B exemplarily shows a partial enlarged view of part I in FIG. 4A.

[0057] FIG. 4C exemplarily shows a partial front view when the spring modules in FIG. 1A is assembled to the mounting rack in FIG. 2.

[0058] FIG. 4D schematically shows a perspective view when the spring modules in FIG. 1A is assembled to the mounting rack in FIG. 2.

[0059] FIG. 5A exemplarily shows a perspective view of a spring module according to another preferred embodiment of the present disclosure.

[0060] FIG. 5B exemplarily shows a spring bracket of the spring module in FIG. 5A.

[0061] FIG. 5C exemplarily shows an exploded view of the spring module in FIG. 5A.

[0062] FIG. 5D exemplarily shows a bottom view of the spring module in FIG. 5A.

[0063] FIG. 5E schematically shows a partial front view when the spring modules in FIG. 5A is assembled to the mounting rack in FIG. 2.

[0064] FIG. 5F exemplarily shows a condition in which a flexible connecting piece of the spring module in FIG. 5A is connected with the flexible connecting piece of an adjacent spring module.

[0065] FIG. 5G exemplarily shows the flexible connecting piece of the spring module in FIG. 5A.

[0066] FIG. 5H exemplarily shows a condition in which the flexible connecting pieces of the spring module in 5A is connected with the flexible connecting pieces of adjacent spring modules when the spring module is mounted on the mounting rack.

[0067] FIG. 6 exemplarily shows a condition when a plurality of the spring modules in FIG. 1A are stacked and nested together.

[0068] FIG. 7A exemplarily shows a spring module with threads.

[0069] FIG. 7B exemplarily shows a condition when a plurality of the spring modules in FIG. 7A are stacked and nested together.

[0070] FIG. 7C exemplarily shows a spring module having a snap structure.

[0071] FIG. 7D exemplarily shows a condition when a plurality of the spring modules in FIG. 7C are stacked and nested together.

[0072] FIG. 7E exemplarily shows a partial enlarged view of part II in FIG. 7D.

[0073] FIG. 8 exemplarily shows a perspective view when spring modules according to yet another preferred embodiment of the present disclosure are mounted on a mounting rack according to another preferred embodiment of the present disclosure.

[0074] FIG. 9A exemplarily shows a partial perspective view of a longitudinally extending section bar of the mounting rack in FIG. 8.

[0075] FIG. 9B exemplarily shows a perspective view of a flexible connector of the mounting rack in FIG. 8.

[0076] FIG. 9C exemplarily shows a partial front view of the mounting rack in FIG. 8 in an unfolded state.

[0077] FIG. 9D exemplarily shows a front view of the mounting rack in FIG. 8 in a folded state.

[0078] FIG. 10A exemplarily shows a perspective view of the spring module in FIG. 8.

[0079] FIG. 10B exemplarily shows a front view of the spring module in FIG. 8.

[0080] FIG. 10C exemplarily shows a first half of a spring bracket of the spring module in FIG. 10A.

[0081] FIG. 10D exemplarily shows a second half of the spring bracket of the spring module in FIG. 10A.

[0082] FIG. 11A exemplarily shows a partial front view of the spring module and the mounting rack in FIG. 8 in a first assembled state.

[0083] FIG. 11B exemplarily shows a partial front view of the spring module and the mounting rack in FIG. 8 in a second assembled state.

[0084] FIG. 12A exemplarily shows a perspective view of a spring module according to yet another preferred embodiment of the present disclosure.

[0085] FIG. 12B exemplarily shows a perspective view of a spring bracket of the spring module in FIG. 12A.

[0086] FIG. 12C exemplarily shows a front view of the spring bracket in FIG. 12A.

[0087] FIG. 12D exemplarily shows a top view of the spring bracket in FIG. 12A.

[0088] FIG. 13A exemplarily shows that the spring modules in FIG. 12A are assembled to a mounting rack.

[0089] FIG. 13B exemplarily shows a partial enlarged view of part IR in FIG. 13A.

[0090] FIG. 13C schematically shows a partial front view when the spring modules in FIG. 13A is assembled to the mounting rack.

[0091] FIG. 13D exemplarily shows a partial enlarged view of part IV in FIG. 13C.

[0092] FIG. 14A exemplarily shows a perspective view of a spring module according to yet another preferred embodiment of the present disclosure.

[0093] FIG. 14B exemplarily shows an exploded view of the spring module in FIG. 14A.

[0094] FIG. 14C exemplarily shows a front view of the spring module in FIG. 14A.

[0095] FIG. 14D exemplarily shows a side view of the spring module in FIG. 14A.

[0096] FIG. 14E exemplarily shows a top view of the spring module in FIG. 14A.

[0097] FIG. 15 exemplarily shows a condition when a plurality of the spring modules in FIG. 14A are stacked and nested together.

[0098] FIG. 16 exemplarily shows that the spring modules in FIG. 14A are assembled to a mounting rack of a spring cushion.

[0099] FIG. 17A exemplarily shows a perspective view of spring modules according to yet another preferred embodiment of the present disclosure.

[0100] FIG. 17B exemplarily shows an exploded view of the spring modules in FIG. 17A.

[0101] FIG. 17C exemplarily shows a front view of the spring modules in FIG. 17A.

[0102] FIG. 17D exemplarily shows a side view of the spring modules in FIG. 17A.

[0103] FIG. 17E exemplarily shows a top view of the spring modules in FIG. 17A.

[0104] FIG. 18 exemplarily shows a condition when a plurality of the spring modules in FIG. 17A are stacked and nested together.

[0105] FIG. 19 exemplarily shows that the spring modules in FIG. 17A are assembled to a mounting rack of a spring cushion.

[0106] FIG. 20A exemplarily shows a spring cushion according to a preferred embodiment of the present disclosure.

[0107] FIG. 20B exemplarily shows the internal structure of the spring cushion in FIG. 20A.

[0108] FIG. 20C exemplarily shows an exploded view of the spring cushion in FIG. 20A.

[0109] FIG. 21A exemplarily shows a one-piece fixing net for spring modules in a spring cushion according to a preferred embodiment of the present disclosure.

[0110] FIG. 21B exemplarily shows a condition when the one-piece fixing net in FIG. 21A is sleeved on spring modules.

[0111] FIG. 22A exemplarily shows a one-piece fixing net for spring modules in a spring cushion according to another preferred embodiment of the present disclosure.

[0112] FIG. 22B exemplarily shows that the one-piece fixing net in FIG. 22A with its periphery bent.

[0113] FIG. 22C exemplarily shows a condition when the one-piece fixing net in FIG. 22A is sleeved on the spring modules and hooked on the mounting rack.

[0114] FIG. 22D exemplarily shows a partial enlarged view of part V in FIGS. 22C.

[0115] FIG. 23A exemplarily shows a top structure of a sponge cover for a spring cushion according to a preferred embodiment of the present disclosure.

[0116] FIG. 23B exemplarily shows a sectional view of the top structure of the sponge cover in FIG. 23A.

[0117] FIG. 24A exemplarily shows filling sponge strips for a spring cushion according to a preferred embodiment of the present disclosure.

[0118] FIG. 24B exemplarily shows an exploded view of a spring cushion having the sponge filled strips shown in FIG. 24A.

[0119] FIG. 24C exemplarily shows a one-piece fixing net in FIG. 24B.

[0120] FIG. 25A exemplarily shows gap-filling spring modules for spring modules in a spring cushion according to a preferred embodiment of the present disclosure.

[0121] FIG. 25B exemplarily shows an exploded view of a spring cushion having the gap-filling spring modules shown in FIG. 25A.

[0122] FIG. 25C exemplarily shows the one-piece fixing net in FIG. 25B.

[0123] FIG. 25D exemplarily shows a condition when the gap-filling spring modules in FIG. 25A are assembled on the one-piece fixing net in FIG. 25C.

[0124] FIG. 25E exemplarily shows a perspective view of the gap-filling spring module in FIG. 25A.

[0125] FIGS. 26A-26B exemplarily show a spring module with constraint holes.

[0126] FIGS. 27A-27C exemplarily show a constraint member for constraining a spring module.

[0127] FIG. 27D exemplarily shows a condition when a plurality of constraint members shown in FIGS. 27A-27C are stacked and nested together.

[0128] FIG. 27E exemplarily shows a condition when the constraint members shown in FIGS. 27A-27C are arranged on the spring modules.

[0129] FIGS. 28A-28C exemplarily show a rotary fixing device of a spring module.

[0130] FIGS. 28D and 28E exemplarily show a condition when two spring modules are fixed together via the rotary fixing device shown in FIGS. 28A-28C.

[0131] FIG. 28F is a partial enlarged view of FIG. 28E.

[0132] FIGS. 29A and 29B exemplarily show an embodiment of a locking structure of a spring module.

[0133] FIG. 29C exemplarily shows a condition when a plurality of spring modules are interlocked together through the locking structures shown in FIGS. 29A and 29B.

[0134] FIGS. 30A and 30B exemplarily show another embodiment of a locking structure of a spring module.

[0135] FIG. 30C exemplarily shows a condition when a plurality of spring modules are combined together via the locking structures shown in FIGS. 30A and 30B.

[0136] FIG. 30D exemplarily shows yet another embodiment of a locking structure of a spring module.

[0137] FIGS. 30E and 30F exemplarily show two conditions when a plurality of spring modules are combined together via the locking structures shown in FIG. 30D.

[0138] FIGS. 31A and 31B exemplarily show an embodiment of a spring module having a T-shaped connection.

[0139] FIG. 31C exemplarily shows a condition when two spring modules having the T-shaped connections shown in FIGS. 31A and 31B are connected together via an I-shaped connector.

[0140] FIG. 31D exemplarily shows a condition when multiple rows of the spring modules having the T-shaped connections shown in FIGS. 31A and 31B are connected together via the I-shaped connectors shown in FIG. 31C.

[0141] FIG. 31E exemplarily shows another embodiment of a spring module having a T-shaped connection.

[0142] FIG. 31F exemplarily shows an I-shaped connector for connecting the spring module shown in FIG. 31E.

[0143] FIGS. 31G and 31H exemplarily show a condition when a plurality of spring modules shown in FIG. 31E are connected together through the I-shaped connectors shown in FIG. 31F.

[0144] FIGS. 31I and 31J exemplarily show an embodiment of a spring module having a wedge-shaped splicing part.

[0145] FIG. 31K exemplarily shows a condition when two spring modules shown in FIGS. 31I and 31J are spliced together.

[0146] FIGS. 31L and 31M exemplarily show spring cushions of different sizes assembled by the spring modules and the I-shaped connectors shown in FIGS. 31E-31H.

[0147] FIGS. 31N and 31P exemplarily show spring cushions of different sizes assembled by the spring modules shown in FIGS. 31I-31K and the I-shaped connectors shown in FIG. 31F.

[0148] FIG. 32A exemplarily shows a spring module in which a base and an end cover can be snapped together according to a preferred embodiment of the present disclosure.

[0149] FIGS. 32B-32D exemplarily show a perspective view, a top view and a side view of the base of the spring module shown in FIG. 32A, respectively.

[0150] FIGS. 32E and 32F exemplarily show a perspective view and a top view of the end cover of the spring module shown in FIG. 32A, respectively.

[0151] FIG. 32G and FIG. 32H exemplarily show a perspective view and a top view when the base and the end cover of the spring module shown in FIG. 32A are snapped together, respectively.

[0152] FIG. 32I exemplarily shows a condition when a plurality of the spring modules in a compressed configuration shown in FIGS. 32G and 32H are stacked together.

[0153] FIGS. 32J-32M exemplarily show spring modules in which a base and an end cover can be snapped together according to other preferred embodiments of the present disclosure, respectively.

[0154] FIG. 33A exemplarily shows a spring module in which a base and an end cover can be snapped together according to another preferred embodiment of the present disclosure.

[0155] FIG. 33B exemplarily shows an exploded view of the spring module shown in FIG. 33A.

[0156] FIG. 33C exemplarily shows a perspective view of a spring bag in the spring module shown in FIG. 33A.

[0157] FIG. 33D exemplarily shows a condition when the base and the end cover of the spring module shown in FIG. 33A are snapped together.

[0158] FIG. 33E exemplarily shows the base of the spring module shown in FIG. 33A,

[0159] FIG. 33F exemplarily shows the end cover of the spring module shown in FIG. 33A.

[0160] FIG. 33G exemplarily shows a condition when the base and the end cover of the spring module shown in FIG. 33A are snapped together.

[0161] FIG. 33H exemplarily shows a spring module in which a base and an end cover can be snapped together according to yet another preferred embodiment of the present disclosure.

[0162] FIG. 33I exemplarily shows a condition when the base and the end cover of the spring module shown in FIG. 33H are snapped together.

[0163] FIG. 33J exemplarily shows a condition when a plurality of the spring modules shown in FIG. 33A are connected together via a flexible bottom pad.

[0164] FIG. 33K exemplarily shows a condition when a plurality of the spring modules shown in FIG. 33H are connected together via a flexible bottom pad.

[0165] FIG. 33L, exemplarily shows a condition when two rows of the spring modules shown in FIG. 33H are connected together via a flexible bottom pad.

[0166] FIGS. 33M and 33N exemplarily show a condition when the bottom pad with two rows of the spring modules mounted thereon shown in FIG. 33L is folded.

[0167] FIG. 33P exemplarily shows a spring cushion having the spring modules and the flexible bottom pads as shown in FIG. 33L.

[0168] FIG. 34A exemplarily shows a spring module in which a base and an end cover can be snapped together according to yet another preferred embodiment of the present disclosure.

[0169] FIGS. 34B-34D exemplarily show a perspective view, a top view and a side view of the base of the spring module shown in FIG. 34A, respectively.

[0170] FIGS. 34E and 34F exemplarily show a perspective view and a top view of the end cover of the spring module shown in FIG. 34A, respectively.

[0171] FIG. 34G exemplarily shows a condition when the base and the end cover of the spring module shown in FIG. 34A are snapped together.

[0172] FIGS. 35A and 35B exemplarily show a perspective view and a side view of a spring module according to yet another preferred embodiment of the present disclosure, respectively.

[0173] FIGS. 35C and 35D exemplarily show a perspective view and a side view of a spring module according to yet another preferred embodiment of the present disclosure, respectively.

[0174] FIG. 35E exemplarily shows a condition when a plurality of the spring modules shown in FIGS. 35A to 35D are nested together.

[0175] FIGS. 35F and 35G exemplarily show an exploded view and a sectional view of a spring module according to yet another preferred embodiment of the present disclosure, respectively.

[0176] FIG. 35H is a partial enlarged view of FIG. 35G.

[0177] FIG. 35I exemplarily shows a condition when a plurality of the spring modules shown in FIGS. 35F and 35G are nested together.

[0178] FIG. 35J exemplarily shows a perspective view of a spring module according to yet another preferred embodiment of the present disclosure.

[0179] FIG. 35K exemplarily shows a conical spring in the spring module shown in FIG. 35J.

[0180] FIGS. 36A and 36B exemplarily show a perspective view and a perspective view of a spring module according to yet another preferred embodiment of the present disclosure, respectively.

[0181] FIG. 36C exemplarily shows a perspective view of a spring module according to yet another preferred embodiment of the present disclosure.

[0182] FIG. 36D exemplarily shows a condition when the spring module shown in FIG. 36C is compressed and stored in a storage box,

[0183] FIG. 36E exemplarily shows a condition when a plurality of the storage boxes shown in FIG. 36D are stacked together.

[0184] FIG. 37 exemplarily shows a perspective view of a spring module according to yet another preferred embodiment of the present disclosure.

[0185] FIGS. 38A and 38B exemplarily show a stereoscopic exploded view and a stereoscopic sectional view of a spring module (spring bag) according to yet another preferred embodiment of the present disclosure, respectively.

[0186] FIGS. 39A and 39B exemplarily illustrate conditions when the spring bag shown in FIGS. 38A and 38B are fixed on the base in different fixing ways, respectively.

[0187] FIG. 39C exemplarily shows a condition when a plurality of the spring modules shown in FIG. 39A or 39B are nested together.

[0188] FIGS. 40A to 40C exemplarily show different embodiments of non-conical springs that can be used in the spring module of the present disclosure.

[0189] FIG. 40D exemplarily shows a spring module having the spring shown in FIG. 40B.

[0190] FIG. 40E exemplarily shows a different embodiment of a conical spring that can be used in the spring module of the present disclosure.

[0191] FIG. 40F exemplarily shows a spring module having the conical spring shown in FIG. 40E.

[0192] FIG. 40G exemplarily shows a different embodiment of a conical spring that can be used in the spring module of the present disclosure.

[0193] FIG. 40H exemplarily shows a spring module having the conical spring shown in FIG. 40G.

[0194] FIG. 41A exemplarily shows a spring cushion according to yet another preferred embodiment of the present disclosure.

[0195] FIG. 41B exemplarily shows a spring cushion according to yet another preferred embodiment of the present disclosure.

[0196] FIG. 41C exemplarily shows a sponge pad in the spring cushion shown in FIG. 41B.

[0197] FIG. 41D exemplarily shows a spring cushion according to yet another preferred embodiment of the present disclosure.

[0198] FIG. 42A exemplarily shows a fixing net assembly for a spring cushion according to yet another preferred embodiment of the present disclosure.

[0199] FIG. 42B exemplarily shows a partial sectional view of the fixing net assembly shown in FIG. 42A.

[0200] FIG. 42C exemplarily shows an exploded view of a fixing net assembly for a spring cushion according to yet another preferred embodiment of the present disclosure.

[0201] FIGS. 42D to 42G exemplarily show partial cross-sectional views of the fixing net assembly shown in FIG. 42C.

[0202] FIG. 42H exemplarily shows a spring cushion according to yet another preferred embodiment of the present disclosure.

[0203] FIG. 42I exemplarily shows a sectional view of the spring cushion shown in FIG. 42H.

[0204] FIG. 42J exemplarily shows a spring cushion according to yet another preferred embodiment of the present disclosure.

[0205] FIG. 42K exemplarily shows a sectional view of the spring cushion shown in FIG. 42J.

[0206] FIG. 42L exemplarily shows a spring pad in the spring cushions shown in FIGS. 42H and 42J.

[0207] FIG. 42M exemplarily shows a partial sectional view of the spring pad shown in FIG. 42L.

[0208] FIG. 42N exemplarily shows a spring cushion according to yet another preferred embodiment of the present disclosure.

[0209] FIG. 42P exemplarily shows a spring cushion according to yet another preferred embodiment of the present disclosure.

[0210] FIG. 42Q exemplarily shows a retracted state of the spring cushion shown in FIG. 42P.

[0211] FIG. 43A exemplarily shows a spring cushion according to yet another preferred embodiment of the present disclosure.

[0212] FIG. 43B exemplarily shows a spring cushion according to yet another preferred embodiment of the present disclosure.

[0213] FIG. 43C exemplarily shows an outer cover having compartments in the spring cushions shown in FIGS. 43A and 43B.

[0214] FIG. 43D exemplarily shows a base cloth in the spring cushions shown in FIGS. 43A and 43B, wherein curtains of the base cloth is in an open state.

[0215] FIG. 43E exemplarily shows the base cloth in the spring cushion shown in FIGS. 43A and 43B, wherein the curtains of the base cloth is in a closed state.

[0216] FIGS. 43F to 43H exemplarily show outer covers having compartments of different shapes/sizes according to different embodiments of the present disclosure.

[0217] FIG. 43I exemplarily shows an outer cover having honeycomb-shaped (hexagonal) compartments according to a preferred embodiment of the present disclosure.

[0218] FIGS. 44A to 44E exemplarily show sponge blocks according to different embodiments of the present disclosure.

[0219] FIG. 45A exemplarily shows a sponge block according to a preferred embodiment of the present disclosure.

[0220] FIG. 45B exemplarily shows the sponge block shown in FIG. 45A in a folded/compressed state.

[0221] FIG. 45C exemplarily shows that the sponge block in a folded/compressed state is received in a storage cup.

[0222] FIG. 46A exemplarily shows a condition when a plurality of the sponge blocks shown in FIG. 45A are received in an elongated storage bag.

[0223] FIGS. 46B and 46C exemplarily illustrate packaging methods of the elongated storage bag receiving a plurality of the sponge blocks shown in FIG. 46A, respectively.

[0224] FIGS. 47A to 47C exemplarily show yet another packaging method of the sponge block according to the present disclosure.

[0225] FIGS. 48A to 48F exemplarily show a sponge block storage box and a sponge block receiving method according to a preferred embodiment of the present disclosure.

[0226] FIGS. 49A and 49B exemplarily show an outer cover for a spring cushion according to a preferred embodiment of the present disclosure.

[0227] FIGS. 50A and 50B exemplarily show an outer cover for a spring cushion according to another preferred embodiment of the present disclosure.

[0228] FIGS. 51A to 51C exemplarily illustrate components of different parts of the outer covers shown in FIGS. 49A and 49B as well as FIGS. 50A and 50B, respectively.

DETAILED DESCRIPTION OF EMBODIMENTS

[0229] The spring module and the spring cushion of the present disclosure will be described in detail below with reference to the accompanying drawings. What are described herein are only preferred embodiments according to the present disclosure, and those skilled in the art can think of other ways to achieve the present disclosure on the basis of the preferred embodiments, which also fall within the scope of the present disclosure.

[0230] FIGS. 1A to 1F exemplarily show a spring module 100 according to a first preferred embodiment of the present disclosure. As shown in the figures, the spring module 100 comprises a spring bracket 120 and a conical spring 110 provided in the spring bracket 120. The spring bracket 120 is used for removably mounting the spring module 100 to a foldable mounting rack. The spring bracket 120 comprises a base 121, an end cover 122 and a plurality of flexible straps 123, in a preferred embodiment, the number of the flexible straps 123 is four, and the flexible straps 123 are uniformly distributed around the periphery of the spring bracket 120. Of course, the number of the flexible straps 123 may also be two, six or other numbers. The base 121 has a spring mounting seat, the center of which is provided with an opening 1211 and a spring fixing part for fixing the conical spring 110, the base 121 further optionally comprises an module mounting part for removably mounting the spring module to the mounting rack, the large-diameter end of the conical spring 110 is fixed to the spring fixing part, and the small-diameter end of the conical spring 110 abuts against the end cover 122. In various embodiments of the present disclosure, the spring fixing part may be a hook part or a recess, and in the present embodiment, the spring fixing part is configured as a plurality of hook parts 1212 uniformly arranged around the inner circumference of the opening 1211. The flexible straps 123 are provided outside the conical spring 110, and two ends of each flexible strap 123 are fixedly connected to the base 121 and the end cover 122, respectively. When the spring 110 is installed in the spring bracket 120, it can have a predetermined initial pressure, such that the spring module has a desired stiffness. With the support of the spring, the spring module 100 is substantially frustoconical.

[0231] Preferably, the spring bracket 120 is a one-piece spring bracket formed integrally, however, of course, it can also be an assembly assembled from a plurality of components.

[0232] As mentioned above, the spring bracket 120 is substantially frustoconical, which enables the end cover 122 of the spring module 100 to enter into the interior of another spring module through the opening 1211 of the base 121 of the other spring module, thus forming nesting, as shown in FIG. 6.

[0233] In order to form a more stable nesting, preferably, the top of the base 121 is provided with an annular wall extending around the opening 1211, and the outside surface of the annular wall is provided with threads 124 (as shown in FIG. 7A), when a plurality of spring modules 100 are

nested the bottom wall of the slideway 1213 of one spring module 100 can enter between the threads 124 and the top of the base 121 of another spring module 100 by rotation, thus forming a stable nesting (as shown in FIG. 7B). Alternatively or additionally, the outer periphery of the base 121 is provided with one or more snap parts 125 extending upward, and one or more snap notches 126 located below the snap parts 125 (as shown in FIG. 7C), then when a plurality of spring modules 100 are nested, the snap parts 125 of the lower spring module can be snapped into the corresponding snap notches 126 of the upper spring module, thus forming a stable nesting. (as shown in FIGS. 7D and 7E).

[0234] Preferably, the module mounting part is configured as two slideways 1213 arranged in parallel at the bottom of the base 121, and the base 121 can be slidably mounted onto the slide rails of the foldable mounting rack, and the slideways 1213 are configured to be hook parts which can be hooked onto the slide rails of the mounting rack in order to prevent the spring module 100 from being separated from the mounting rack.

[0235] Preferably, the opening 1211 is a circular opening, and the middle part of each slideway 1213 is formed with an arc part matching the circular radian of the opening 1211, such as part A in FIG. 1F, so as not to hinder the superposition and nesting of a plurality of spring modules. Alternatively, each slideway 1213 may be configured as segmented slideways which are discontinuous in-between.

[0236] FIGS. 2 and 3A-3D exemplarily show a mounting rack 400 according to a first preferred embodiment of the present disclosure. As shown in the figures, the mounting rack 400 comprises two side frames 410 located at both lateral sides of the mounting rack 400, a plurality of intermediate frames 420 located between the two side frames 410, and a plurality of connectors 430 rotatably connecting the side frames 410 and the intermediate frames 420 with each other. Since the side frames 410 and the intermediate frames 420 can rotate around the connectors 430, the mounting rack 400 is foldable, as shown in FIGS. 3C and 3D in which the mounting rack 400 is in a folded state.

[0237] Preferably, the side frames 410, the intermediate frames 420 and the connectors 430 are all formed of metal, more preferably, the side frames 410 and the intermediate frames 420 are made of steel bars by bending and welding while the connectors 430 are made of metal sheets by winding. And as shown in FIG. 2, both the side frames 410 and the intermediate frames 420 are closed frames.

[0238] As shown in FIG. 2, the side frame 410 has a longitudinal extending part 411 extending along its length and a plurality of transverse protruding parts 412 perpendicular to the longitudinal extending part and extending to one side, the intermediate frame 420 has a longitudinal extending part 421 extending along its length and a plurality of transverse protruding parts 422 perpendicular to the longitudinal extending part and extending to both lateral sides, and the connectors 430 rotatably connect the corresponding transverse protruding parts of two adjacent frames together, such that the mounting rack 400 is foldable.

[0239] As described above, the steel bars at the longitudinal extending parts 411 is configured to be slidably engaged with the slideways 1213 of the base 121, so that the base 121 of the spring module 100 can be slidably mounted onto the mounting rack 400 along the longitudinal extending parts 411, 421 of the mounting rack 400. That is, the longitudinal extending parts 411, 421 can serve as slide rails

cooperating with the slideways 1213 of the base 121. Preferably, the middle portions 413, 423 of the steel bars at the longitudinal ends of the side frames 410 and the intermediate frames 420 protrude in a direction perpendicular to the plane of the longitudinal extending parts and the transverse protruding parts (downward direction shown in the figure), so that the slideways of the spring module can slide through the ends of the frames and further along the longitudinal extending parts 411, 421.

[0240] In a preferred embodiment according to the present disclosure, there may be two types of side frames and two types of intermediate frames with different lengths, in order to facilitate the folding of the mounting rack. For example, the side frame 410 may comprise a first side frame 410A having a longer length and a second side frame 410B having a shorter length, and the intermediate frame 420 may comprise a plurality of first intermediate frames 420A and a plurality of second intermediate frames 420B spaced apart from each other, and wherein, similarly, the longitudinal length of the first intermediate frames 420A are slightly greater than that of the second intermediate frames 420B. The purpose of arranging frame members with different lengths is that, when folding, the protrusions 413, 423 at the ends of adjacent frame members can readily realize folding without interfering with each other. FIGS. 3C and 3D show the folded state of the frame 400 with frame members having different lengths, in which the ends A of the longer frame members and the ends B of the shorter frame members are staggered from each other without interference.

[0241] FIGS. 4A-4D exemplarily show that the spring modules 100 according to the first preferred embodiment of the present disclosure are mounted onto the mounting rack 400 according to the first preferred embodiment of the present disclosure. As shown in the figures, the slideways 1213 of the spring module 100 can be slidably mounted onto the longitudinal extending parts 411, 421 of the frame members at the notches formed by the protrusions 413, 423.

[0242] FIGS. 5A-5E exemplarily show a spring module 200 according to a second preferred embodiment of the present disclosure and its installation on the mounting rack 400. As shown in the figures, the spring module 200 comprises a spring bracket 220 and a conical spring 110 provided in the spring bracket 220. The spring bracket 220 is used to removably mount the spring module 200 to the mounting rack 400 which is foldable. The spring bracket 220 comprises a base 221, an end cover 222 and a plurality of flexible straps 223. In a preferred embodiment, the number of the flexible straps 223 is four, and the flexible straps 223 are uniformly distributed around the periphery of the spring bracket 220. The base 221 comprises a spring mounting seat, the center of the spring mounting seat is provided with an opening 2211, and a spring fixing part for fixing the conical spring 110, and the base 221 further comprises a module mounting part for detachably mounting the spring module onto the mounting rack, the large-diameter end of the conical spring 110 is fixed to the spring fixing part while the small-diameter end of the conical spring 110 abuts against the end cover 222. In this preferred embodiment, the spring fixing part is configured as a plurality of hook parts 2212 uniformly arranged around the inner circumference of the opening 2211. The flexible straps 223 are provided outside the conical spring 110, and two ends of each flexible strap 223 are fixedly connected to the base 221 and the end cover 222, respectively. When the spring 110 is installed in the

spring bracket 220, it can have a predetermined initial pressure, such that the spring module has a desired stiffness. With the support of the spring, the spring module 200 is substantially frustoconical. Different from the spring bracket 120, the center of the end cover 222 of the spring bracket 220 has a circular opening 224, that is, the end cover 222 is an annular end cover.

[0243] Preferably, the spring bracket 220 is a one-piece spring bracket formed integrally, although of course, it can also be an assembly assembled from a plurality of components.

[0244] As described above, the spring bracket 220 is substantially frustoconical, which enables the end cover 222 of the spring module 200 to enter into the interior of another spring module through the opening 2211 of the base 221 of the other spring module, thus forming nesting. In order to form more stable nesting, the threads and the snap structures of the base 121 of the spring module 100 can similarly be applied to the base 221 of the spring module 200.

[0245] Preferably, the module mounting part of the spring module 200 is configured as two slideways 2213 parallel with each other arranged at the bottom of the base 121, unlike the inward slideways 1213 with the directions of the openings facing with each other, the slideways 2213 are outward slideways with the directions of the openings facing away from each other. The base 221 can be slidably mounted onto the slide rails of the mounting rack 400, i.e., the longitudinal extending parts 411, 421 of the frame members, through the slideways 2213. In the present embodiment, as shown in FIG. 5D, each slideway 1213 may be configured as segmented slideways which are discontinuous in-between. Moreover, similar to the slideway 1213, the slideway 2213 is a hook part, which can be hooked onto the slide rail of the mounting rack in order to prevent the spring module 200 from being disengaged from the mounting rack.

[0246] Figs. 5E-5G exemplarily illustrate a flexible connecting piece structure that may be applied to the spring module 200, which may be used to form a connecting relationship between a plurality of spring modules mounted on the mounting rack, such that a single spring module is not easy to flip and fall over, and the springs of the plurality of spring modules are not easy to wind together. As shown in the figures, a flexible connecting piece 225 may be integrally formed on the outer side of the flexible strap 223, when the plurality of spring modules 200 are mounted onto the mounting rack, the flexible connecting piece 225 of one spring module can be detachably connected with the corresponding flexible connecting piece 225 of an adjacent spring module. Preferably, the flexible connecting piece 225 comprises a neck part 2251 and a T-shaped groove 2252, and the neck 2251 as well as the T-shaped groove 2252 are such designed that one of two adjacent flexible connecting pieces can be detachably locked in the T-shaped groove 2252 of the other flexible connecting piece through the neck 2251. More preferably, the vertical distance between the flexible connecting piece 225 and the end cover 222 is about $\frac{1}{3}$ of the overall height of the spring module 200.

[0247] FIG. 5H exemplarily shows that a plurality of spring modules 200 mounted on the mounting rack are connected with each other via flexible connecting pieces 225.

[0248] Those skilled in the art will know that the above-mentioned flexible connecting piece structure may also be applied to flexible straps of spring modules in other pre-

ferred) embodiments of the present disclosure, such as the spring module 100 and the spring module 300 to be described below.

[0249] FIGS. 8 and 9A-9D exemplarily illustrate a foldable mounting rack 500 according to a second preferred embodiment of the present disclosure. As shown in the figures, the mounting rack 500 comprises a plurality of longitudinally extending section bars 510 and a plurality of flexible connectors 520 positioned between the plurality of longitudinal section bars and configured to connect them together, a middle portion 522 of the flexible connector 520 is thin and can be bent to form a flexible hinge. Both the longitudinal section bar 510 and the flexible connector 520 may be made of plastic, and the longitudinal section bar 510 may be a plastic part formed by extrusion. As shown clearly in FIGS. 9A and 9B, the middle portion of the longitudinal section bar 510 is provided with two T-shaped grooves 511 with downward openings, and the top of the flexible connector 520 is provided with T-shaped projections 521 matching the shapes of the T-shaped grooves 511, and the T-shaped grooves 511 can slidably accommodate the T-shaped projections 521, thus enabling the plurality of longitudinal section bars 510 to be connected together through the flexible connectors 520, as shown in FIG. 9C.

[0250] Since the middle portion 522 of the flexible connector 520 is thin and can be bent, the mounting rack 500 is substantially foldable, and FIG. 9D shows the mounting rack 500 in a folded state.

[0251] As shown in FIGS. 9A and 9B, the longitudinal section bar 510 comprises a pair of first transverse projections 512 extending transversely and a pair of second transverse projections 513 provided above which, the distance between the pairs of first transverse projections 512 is greater than the distance between the pairs of second transverse projections 513.

[0252] FIGS. 10A to 10D exemplarily illustrate a spring module 300 according to a third preferred embodiment of the present disclosure. As shown in the figures, similar to the spring modules 100, 200, the spring module 300 comprises a spring bracket 320 and a conical spring 110 provided in the spring bracket 320. The spring bracket 320 is used to removably mount the spring module 300 onto the foldable mounting rack 500. The spring bracket 320 comprises a base 321, an end cover 322 and a plurality of flexible straps 323. In a preferred embodiment, the number of the flexible straps 323 is four, and the flexible straps 323 are uniformly distributed around the periphery of the spring bracket 320. The base 321 comprises a spring mounting seat, the center of which is provided with an opening 3211 at the center and a spring fixing part for fixing the conical spring 110, and the base 321 further comprises a module mounting part for removably mounting the spring module onto the mounting rack, the large-diameter end of the conical spring 110 is fixed to the spring fixing part while the small-diameter end of the conical spring 110 abuts against the end cover 322. In this preferred embodiment, the spring fixing part is configured to be an annular groove 3212 formed around the inner circumference of the opening 3211. The flexible straps 323 are provided outside the conical spring 110 and two ends of each flexible strap 323 are fixedly connected to the base 321 and the end cover 322, respectively. When the spring 110 is installed in the spring bracket 320, it may have a predetermined initial pressure, such that the spring module has a

desired stiffness. With the support of the spring, the spring module 300 is substantially frustoconical.

[0253] As described above, the spring bracket 320 is substantially frustoconical, which enables the end cover 322 of the spring module 300 to enter into the interior of another spring module through the opening 3211 of the base 321 of the other spring module, thus forming nesting. In order to form a more stable nesting, the segmented threads and the snap structure of the bases 121, 221 of the spring modules 100, 200 may also be applied to the base 321 of the spring module 300.

[0254] Preferably, the module mounting part of the spring module 300 comprises two slideways 327 parallel with each other arranged at the bottom of the base 321, through which the base 321 can be slidably mounted onto the slide rails of the mounting rack 500, i.e., the first transverse projections 512 of the longitudinal section bar 510. The slideways 327 at the bottom of the base 321 may be slidably cooperated with the first transverse projections 512, such that the spring module 300 may be mounted onto the mounting rack 500 through the base 321, as shown in FIG. 11A. Alternatively or additionally, the module mounting part of the spring module further comprises two slideways 328 arranged parallel to each other at the top of the end cover 322, which may be slidably cooperated with the slide rails of the longitudinal section bar 510, i.e., the second transverse projections 513, so that the spring module 300 may be mounted onto the mounting rack 500 through the end cover 322, as shown in FIG. 11B.

[0255] Different from the spring modules 100 and 200, the spring bracket 320 of the spring module 300 is a two-piece spring bracket, which is removably assembled from a first half 320A as shown in FIG. 10C and a second half 320B as shown in FIG. 10D through a snap device such as a plug 325 and a socket 326. The first half 320A and the second half 320B respectively comprise one or more complete flexible straps 323, part of the base 321 and part of the end cover 322, and the first half 320A as well as the second half 320B are integrally formed. Preferably, the first half 320A and the second half 320B respectively comprise two complete flexible straps 323, a half base 321 and a half end cover 322.

[0256] FIGS. 12A to 12D exemplarily show a spring module 700 according to a fourth preferred embodiment of the present disclosure. As shown in the figures, the spring module 700 comprises a spring bracket 720, and a conical spring 110 provided in the spring bracket 720. The spring bracket 720 is used to detachably mount the spring module 700 onto the foldable mounting rack. The spring bracket 720 comprises a base 721, an end cover 722 and a plurality of flexible straps 723. In a preferred embodiment, the number of the flexible straps 723 is four, and the flexible straps 723 are uniformly distributed around the periphery of the spring bracket 720. The base 721 comprises a spring mounting seat, the center of which is provided with a circular opening. 7211 and a spring fixing part 7212 for fixing the conical spring 110, and the base 721 further comprises a module mounting part 7213 for removably mounting the spring module onto the mounting rack, the large-diameter end of the conical spring 110 is fixed to the spring fixing part 7212 while the small-diameter end of the conical spring 110 abuts against the end cover 722. In various embodiments of the present disclosure, the spring fixing part may be a hook part or a groove. In the present embodiment, the spring fixing part is a groove 7212 arranged around the inner circumference of

the circular opening 7211. The flexible straps 723 are provided outside the conical spring 110, and two ends of each flexible strap 723 are fixedly connected to the base 721 and the end cover 722, respectively. When the spring 110 is installed in the spring bracket 720, it may have a predetermined initial pressure, such that the spring module has a desired stiffness. With the support of the spring, the spring module 700 is substantially frustoconical.

[0257] As mentioned above, the spring bracket 720 is substantially frustoconical, which enables the end cover 722 of the spring module 700 to enter into the interior of another spring module through the circular opening 7211 of the base 721 of the other spring module, thus forming nesting.

[0258] Preferably, the spring bracket 720 is a one-piece spring bracket formed integrally, as shown in FIGS. 12A-12D, the base 721 of the spring bracket 720 is configured as four parts splicing together, namely a first part 721A, a second part 721B, a third part 721C and a fourth part 721D, wherein the second part 721B is arranged parallel to and opposite to the first part 721A, the third part 721C is arranged adjacent to the first part 721A and is transversely to the first part 721A, and the fourth part 721D is arranged parallel to and opposite to the third part 721C, and further adjacent to the first part 721A as well as the second part 721B. At least one flexible strap 723 is fixedly connected at the top surface of each of said four parts, and the four parts may be detachably butted mutually through a locking device 7216 to form the base 721.

[0259] Preferably, the module mounting part 7213 is configured as two slideways 7213 parallel with each other formed at the outer sides of the third part 721C and the fourth part 721D of the base 721, such that the base 721 may be slidably assembled onto the mounting rack 600 through the sliding fit between the slideways 7213 and the slide rails 611 of the mounting rack 600 (which will be described below), that is, the spring module 700 may be assembled onto the mounting rack with its thick end down. In addition, the top surface of the end cover 722 is further provided with two second slideways 7221 parallel to the slideways 7213, so that the end cover 722 may be slidably assembled onto the mounting rack 600 through the sliding fit between the slideways 7221 and the sliding rails 621 of the mounting rack 600, that is, the spring module 700 may be assembled onto the mounting rack 600 with its thin end down.

[0260] Preferably, in order to enable the relative positions among a plurality of spring modules 700 to be more stable and not easy to be dislocated, flexible connecting belts 7214 are respectively arranged at both sides of the ends of the slideways 7213 positioned at the outer sides of the third part 721C and the fourth part 721D of the base 721, the ends of the flexible connecting belts 7214 are provided with holes, and on the top surface of the end cover 722, two projections 7222 are respectively provided outside each slideway 7221. When a plurality of spring modules 700 are mounted onto the mounting rack 600, the plurality of spring modules 700 may be mounted onto the mounting rack 600 with the thick end down and the thin end down successively at intervals in order to take full advantage of space. The flexible connecting belts 7214 of one spring module 700 mounted onto the mounting rack 600 through the end cover 722 (with the thin end down) may be snapped to the projections 7222 of another adjacent spring module 700 mounted onto the mounting rack 600 through the base 721 (with the thick end

down), thereby enabling the relative positions among the plurality of spring modules 700 to be more stable.

[0261] More preferably, in order to further enable the relative positions among the spring modules 700 assembled in the same orientation to be more stable and prevent them from being dislocated, at least one cylindrical pin 7215 (two in the figures) is arranged at the outer side of the first part 721A of the base 721, and at least one receiving hole 7217 (two in the figures) is arranged at the corresponding position of the outer side of the second part 721B of the base 721. When the plurality of spring modules 700 are mounted onto the mounting rack 600 in rows, the cylindrical pin 7215 of one spring module 700 may be inserted into the corresponding receiving hole 7217 of the adjacent spring module 700 so as to assist alignment and fixation.

[0262] FIGS. 13A to 13D exemplarily show a foldable mounting rack 600 according to a third preferred embodiment of the present disclosure. As shown in the figures, the mounting rack 600 comprises a plurality of longitudinally extending first section bars 610 and a plurality of longitudinally extending second section bars 620, wherein the first section bar 610 comprises a longitudinally extending flat body and longitudinally extending slide rails 611 on both transverse sides of the flat body, and the second section bar 620 comprises a longitudinally extending flat body and a longitudinally extending slide rail 621 located in the middle of the top surface of the flat body. The first section bars 610 and the second section bars 620 are arranged at intervals along the transverse direction and connected together through a plurality of flexible connectors, which can be bent thus allowing the mounting rack 600 to be foldable.

[0263] Furthermore, the base 721 of the spring module 700 may be slidably mounted onto the mounting rack 600 through the sliding fit between the slideways 7213 and the slide rails 611, and the end cover 722 of the spring module 700 may be slidably mounted onto the mounting rack 600 through the sliding fit between the slideways 7221 and the slide rails 621. The longitudinal section bars 610, 620 as well as the flexible connectors may all be made of plastic, and the longitudinal section bars 610, 620 may be plastic parts formed by extrusion. As clearly shown in FIG. 13D, the cross-sectional shape of the slide rails 621 is substantially inverted trapezoidal, and the shape of the gap between two slide rails 7221 corresponds to the cross-sectional shape of the slide rails 621, such that the spring module 700 mounted with the thin end down is impossible to move in the direction perpendicular to the mounting rack 600. Similarly, the slide rail 611 is a hook part, which prevents the spring module 700 mounted with the thick end down from moving in the direction perpendicular to the mounting rack 600.

[0264] The spring module described in the above embodiments only comprises a single conical spring, and the spring module according to the present disclosure may also comprise a plurality of conical springs, in this way, the assembly and disassembly times of the spring modules in the spring cushion may be reduced.

[0265] FIGS. 14A to 14E exemplarily show a spring module 5000 according to a fifth preferred embodiment of the present disclosure. As shown in the figures, the spring module 5000 comprises a spring bracket 5220 and three conical springs 110 arranged in rows in the spring bracket 5220. The spring bracket 5220 may be used to detachably mount the spring module 5000 onto the mounting rack of the spring cushion. The spring bracket 5220 comprises a com-

mon base 5221, a plurality of end covers 5222 and a plurality of flexible straps 5223, wherein two ends of each flexible strap 5223 are fixedly connected to the base 5221 and a corresponding end cover 5222, respectively, in a preferred embodiment, each end cover 5222 is connected with four flexible straps 5223 which are uniformly distributed around the outer side of the corresponding conical spring 110. The base 5221 comprises three spring mounting seats, each of which has a spring fixing part 52212 for fixing the conical spring 110, and a module mounting part 52213 for removably mounting the spring module onto the mounting rack. Each end cover 5222 together with the plurality of flexible straps 5223 connected thereto are configured as substantially frustoconical as a whole, and the internal shape of which matches the shape of the conical spring 110. Each end cover 5222 forms a frustoconical-shaped small-diameter end, and the corresponding spring mounting seats of the base 5221 form a plurality of frustoconical-shaped large-diameter ends, the base 5221 has an opening 52211 at the central position of each large-diameter end, such that a plurality of end covers 5222 as well as most or all flexible straps 5223 of another spring module 5000 may enter into the interior of said spring module 5000 via the corresponding openings 52211 thus forming nesting. The large-diameter end of the conical spring 110 is fixed to the spring fixing part 52212 of the corresponding spring mounting seat while the small-diameter end of the conical spring 110 abuts against the end cover 5222. In this preferred embodiment, the spring fixing part 52212 is configured as a plurality of hook parts 52212 uniformly arranged around the inner circumference of the opening 52211. The flexible straps 5223 are arranged outside the conical spring 110, and two ends of each flexible strap 5223 are fixedly connected to the base 5221 and the corresponding end cover 5222, respectively. When the spring 110 is installed in the spring bracket 5220, it may be provided with a predetermined initial pressure, such that the spring module has a desired stiffness. The center of the end cover 5222 of the spring bracket 5220 may be provided with a circular opening 5224, that is, the end cover 5222 may be an annular end cover.

[0266] Preferably, the spring bracket 5220 is a one-piece spring bracket formed integrally.

[0267] As described above, the spring bracket 5220 presents a plurality of substantially frustoconical shapes, which enables the end covers 5222 of the spring module 5000 to enter into the interior of another spring module through the openings 52211 of the base 5221 of the other spring module thus forming nesting, as shown in FIG. 15.

[0268] Preferably, the module mounting part of the spring module 5000 is configured as one or more pairs of parallel slideways 52213 arranged at the bottom surface of the base 5221. In the embodiment shown in FIGS. 14A-14E, the opening directions of the pair of slideways 52213 face with each other, as an alternative embodiment, the opening directions of each pair of slideways 52213 may also face away from each other. The base 5221 may be slidably mounted onto the mounting rack of the spring cushion through the slideways 52213. In the present embodiment, as shown in FIG. 14C, each slideway 52213 may be configured as segmented slideways which are discontinuous in-between, corresponding to the number of the conical springs 110 and the openings 52211 along the extending direction of the slideway 52213, in the present embodiment, each slideway 52213 comprises four segments 52213A, 52213B, 52213C

and 52213D, and the purpose of segmentation is to prevent the slideways 52213 from interfering with the openings 52211, and further to reduce the size of the base 5221. The slideways 52213 are hook parts, which are configured to be hooked onto the slide rails of the mounting rack so as to prevent the spring module 5000 from being separating from the mounting rack.

[0269] FIG. 16 exemplarily shows a condition when the spring modules 5000 having a plurality of conical springs 110 are mounted onto a mounting rack of a spring cushion.

[0270] FIGS. 17A-17E exemplarily show a spring module 6000 according to a sixth preferred embodiment of the present disclosure. As shown in the figures, the spring module 6000 comprises a spring bracket 6220 and four conical springs 110 distributed in an array manner arranged in the spring bracket 6220. The spring bracket 6220 may be used to removably mount the spring module 6000 onto the mounting rack of the spring cushion. The spring bracket 6220 comprises a common base 6221, a plurality of end covers 6222 and a plurality of flexible straps 6223, wherein two ends of each flexible strap 6223 are fixedly connected to the base 6221 and a corresponding end cover 6222, respectively. In a preferred embodiment, each end cover 6222 is connected with four flexible straps 6223 which are uniformly distributed around the outer side of the corresponding conical spring 110. The base 6221 has four spring mounting seats, each of which has a spring fixing part 62212 for fixing the conical spring 110, and a module mounting part 62213 for removably mounting the spring module onto the mounting rack. Each end cover 6222 and the plurality of flexible straps 6223 connected thereto are configured as substantially frustoconical as a whole, and the internal shape of which matches the shape of the conical spring 110. Each end cover 6222 forms a frustoconical-shaped small-diameter end and the corresponding spring mounting seats of the base 6221 form a plurality of frustoconical-shaped large-diameter ends, the base 6221 has an opening 62211 at the central position of each large-diameter end, such that a plurality of end covers 6222 as well as most or all flexible straps 6223 of another spring module 6000 may enter into the interior of said spring module 6000 via the corresponding openings 62211 thus forming nesting. The large-diameter end of the conical spring 110 is fixed to the spring fixing part 62212 while the small-diameter end of the conical spring 110 abuts against the end cover 6222. In this preferred embodiment, the spring fixing part 62212 is composed of a plurality of hook parts 62212 uniformly arranged around the inner circumference of the opening 62211. The flexible straps 6223 are located outside the conical spring 110, and two ends of each flexible strap 6223 are fixedly connected to the base 6221 and the corresponding end cover 6222, respectively. When the spring 110 is installed in the spring bracket 6220, it may be provided with a predetermined initial pressure, such that the spring module has a desired stiffness. The center of the end cover 6222 of the spring bracket 6220 may be provided with a circular opening 6224, that is, the end cover 6222 may be an annular end cover.

[0271] Preferably, the spring bracket 6220 is a one-piece spring bracket formed integrally.

[0272] As described above, the spring bracket 6220 is substantially frustoconical, which enables the end covers 6222 of the spring module 6000 to enter into the interior of

another spring module through the openings **6221** of the base **6221** of the other spring module thus forming nesting, as shown in FIG. **18**.

[**0273**] Preferably, the module mounting part of the spring module **6000** is composed of one or more pairs of parallel slideways **62213** arranged at the bottom surface of the base **6221**. In the embodiment shown in FIGS. **17A-17E**, the opening directions of two pairs of slideways **62213** face away from each other, as an alternative embodiment, the opening directions of each pair of slideways **62213** may also face with each other. The base **6221** may be slidably mounted onto the mounting rack of the spring cushion through the slideways **62213**. In the present embodiment, as shown in FIG. **17C**, each slideway **62213** may be composed of segmented slideways which are discontinuous in-between and corresponding to the number of the conical springs **110** and the openings **62211** along the extending direction of the slideways **62213**, in the present embodiment, each slideway **62213** comprises three segments **62213A**, **62213B** and **62213C**, and the purpose of segmentation is to prevent the slideways **62213** from interfering with the openings **62211**, and further to reduce the size of the base **6221**, the slideways **62213** are hook parts, which are configured to be hooked onto the slide rails of the mounting rack so as to prevent the spring module **6000** from being separating from the mounting rack.

[**0274**] FIG. **19** exemplarily shows a condition when the spring modules **6000** having a plurality of conical springs **110** are mounted onto a mounting rack of a spring cushion.

[**0275**] It can be known from the above exemplary embodiments that the spring module according to the present disclosure may comprise any number of a plurality of conical springs, and the plurality of conical springs may be distributed in the spring module in any pattern.

[**0276**] According to a preferred embodiment of the present disclosure, in order to better maintain the spring module in the spring cushion in a proper position, the spring cushion **1000** may further comprise a one-piece fixing net. FIGS. **21A** and **21B** show a one-piece fixing net **1300** according to a first preferred embodiment of the present disclosure, which comprises a plurality of ring parts **1310** with each ring part **1310** such configured that part of the corresponding spring module in the spring cushion can pass therethrough. Preferably, when the one-piece fixing net **1300** is arranged on the spring modules, the vertical distance between the ring part **1310** and the end cover of the spring module is about $\frac{1}{3}$ of the overall height of the spring module.

[**0277**] FIGS. **22A-22D** show a one-piece fixing net **1400** according to a second preferred embodiment of the present disclosure. As shown in the figures, the one-piece fixing net **1400** is flexible, and a plurality of hook parts **1420** are provided at the edge of which. When the one-piece fixing net **1400** is arranged on the spring modules, the hook parts **1420** are configured to hook on the mounting rack **400**.

[**0278**] Further preferably, the top of the sponge cover **1100** may comprise a plurality of nest structures **1110**, as shown in FIGS. **23A** and **23B**, and the positions of the plurality of nest structures **1110** correspond to the positions of the end covers of each spring module on the foldable mounting rack in the spring cushion, such that the top of each spring module may be accommodated within the corresponding nest structure, thereby restricting the movement of the spring modules in the lateral direction and

preventing the spring modules from being dislocated or the adjacent springs from being wound together.

[**0279**] As shown in FIGS. **24A** to **24B**, the spring cushion **1000** according to the present disclosure may further comprise a plurality of filling sponge strips **900**, which are placed on the one-piece fixing net **2300**, and the plurality of filling sponge strips **900** are sized to be filled in the gaps between the spring modules as well as the gaps between the frustocones of each spring module in the spring cushion, so as to prevent the spring modules from shaking and dislocation thus improving the use comfort of the spring cushion. As shown in FIG. **24C**, similar to the one-piece fixing nets **1300**, **1400**, the one-piece fixing net **2300** comprises a plurality of ring parts **2310** with each ring part **2310** such configured that part of the corresponding spring module in the spring cushion can pass therethrough. Preferably, when the one-piece fixing net **2300** is arranged on the spring modules, the vertical distance between the ring part **2310** and the end cover of the spring module is about $\frac{1}{3}$ of the overall height of the spring module.

[**0280**] As shown in FIGS. **25C** and **25D**, the spring cushion **1000** of the present disclosure may comprise a one-piece fixing net **3300**, which comprises a plurality of small ring parts **3320** for restraining the spring module in addition to the ring parts **3310**, and the small ring parts **3320** are respectively located between the ring parts **3310**, and the ring parts **3310** as well as the small ring parts **3320** are arranged at intervals in an array manner, such that when the one-piece fixing net **3300** is arranged on the spring modules, the plurality of small ring parts **3320** are just above the gaps between the spring modules as well as the gaps between the frustocones of each spring module.

[**0281**] Similarly, when the fixing net **3300** is arranged on the spring modules, the vertical distance between the ring part **3310** and the end cover of the spring module is about $\frac{1}{3}$ of the overall height of the spring module.

[**0282**] As shown in FIGS. **25A** and **25B**, the spring cushion **1000** of the present disclosure may further comprise a plurality of gap-filling spring modules **800**, which are generally frustoconical, and can be used to fill in the gaps between the spring modules as well as the gaps between the frustoconical shapes of each spring module with the thin end down, so as to prevent the spring modules from shaking and dislocation thus improving the use comfort of the spring cushion. The small-diameter ends of the gap-filling spring modules **800** may be fixed onto the small ring parts **3320** for filling the gaps.

[**0283**] FIG. **25E** exemplarily shows a gap-filling spring module **800** for filling gaps according to a preferred embodiment of the present disclosure. As shown in the figure, the gap-filling spring module **800** comprises a spring bracket **820** and a small conical spring **810** provided in the spring bracket **820**. The spring bracket **820** is used to removably assemble the gap-filling spring module **800** to the one-piece fixing net **3300**. The spring bracket **820** comprises a base **821**, an end cover **822** and a plurality of flexible straps **823**, in a preferred embodiment, the number of the flexible straps **823** is four, and the flexible straps **823** are uniformly distributed around the periphery of the spring bracket **820**. The center of the base **821** comprises a circular opening, and the large-diameter end of the small conical spring **810** is fixed to a spring fixing part of the base **821**, the spring fixing part may be an annular groove extending around the inner circumference of the circular opening of the base **821**. The

small-diameter end of the conical spring **810** abuts against the end cover **822**. The flexible straps **823** are located outside the small conical spring **810**, and two ends of each flexible strap **823** are fixedly connected to the base **821** and the end cover **822**, respectively. When the spring **810** is installed in the spring bracket **820**, it may be provided with a predetermined initial pressure, so that the gap-filling spring module **800** may have a desired stiffness. With the support of the spring, the gap-filling spring module **800** has a frustoconical shape as a whole.

[0284] Preferably, the spring bracket **820** is a one-piece spring bracket formed integrally-, but of course, it may also be an assembly assembled from multiple components.

[0285] As described above, the spring bracket **820** is substantially frustoconical, which enables the end cover **822** of the gap-filling spring module **800** to enter into the interior of another gap-filling spring module through the circular opening of, the base **821** of the other gap-filling spring module thus forming nesting.

[0286] Furthermore, in order to allow the end cover **822** of the gap-filling spring module **800** to be more stably fixed on the small ring part **3320** of the one-piece fixing net **3300**, a plurality of hook parts **8221** extending toward the small-diameter end of the small conical spring **810** may be formed at the outer periphery of the end cover **822**, and the small-diameter end of the gap-filling spring module **800** may be fixed on the small ring part **3320** through the hook parts **8221** so as to fill the gaps. Preferably, the plurality of hook parts **8221** and the plurality of flexible straps **823** are arranged at intervals along the periphery of the gap-filling spring module **800**. Alternatively, the hook part **8221** may also be configured as an annular hook part extending 360 degrees along the entire periphery of the end cover **822**.

[0287] The present disclosure further provides a spring cushion. As shown in FIGS. 20A-20C, a spring cushion **1000** according to a preferred embodiment of the present disclosure may comprise the mounting rack **400**, **500**, **600** as described in the above embodiments, and a plurality of spring modules **100**, **200**, **300**, **700**, **5000**, **6000** mounted on the mounting rack. The spring cushion **1000** may further comprise the sponge cover **1100** sleeved on the plurality of spring modules mounted on the mounting rack, and a cloth cover **1200** sleeved on the sponge cover.

[0288] Various spring modules according to various embodiments of the present disclosure may also have other functional parts/components, which will be described in detail below.

[0289] FIGS. 26A and 26B show a spring module with constraint holes according to a preferred embodiment of the present disclosure, wherein the end cover is provided with a main body part which is substantially planar, and four constraint holes **224a** uniformly distributed around the center of the end cover may be provided in the main body part, and the constraint holes are configured to receive constraint members (FIG. 27A) so as to constrain the relative position between four adjacent spring modules. FIGS. 27A-27C exemplarily show a constraint member **10** for constraining the spring module, the constraint member comprises a square main frame and four cylindrical parts **11** located at four corners of the square main frame, as shown in the figures, the square main frame is provided with reinforcing bars **12** extending along the diagonals of which; Each cylindrical part **11** extends from the square main frame toward the same side in the direction perpendicular to the

square main frame, and the main frame as well as the cylindrical part are such sized that each cylindrical part **11** may be inserted into the corresponding constraint hole **224a** in the end covers of four adjacent spring modules. In addition, each cylindrical part **11** has a tapered end for guiding the cylindrical part **11** to be inserted into the constraint hole **224a**. As shown in FIG. 27C, a snap-fit part **13** is provided on the outer surface of the cylindrical part **11**, and the snap-fit part **13** is configured to be snap fitted in the constraint hole **224a**. As shown in FIG. 27B, the cylindrical part **11** is provided with a central hole **14** in which a groove **15** for receiving the snap-fit part **13** is formed, and the central hole **14** is such sized to receive the tapered end of the cylindrical part **11** of another constraint member **10** so that a plurality of constraint members **10** may be nested with each other, as shown in FIG. 27D.

[0290] FIG. 27E exemplarily shows a condition when a plurality of the spring modules shown in FIG. 26A are fixed together through the constraint members **10** shown in FIG. 27A.

[0291] FIGS. 28A-28C show a spring module with a rotary fixing device according to a preferred embodiment of the present disclosure, the rotary fixing device comprises a pair of protrusions **21** and a pair of arc openings **22** provided on the end cover of the spring module in a central symmetrical manner along the circumferential direction, and the protrusions **21** as well as the arc openings **22** are alternately arranged along the circumferential direction of the end cover. Each protrusion **21** comprises a thin base portion **211a** which is substantially cylindrical, and a thick end **212a** which is substantially frustoconical. Each arc opening **22** comprises a narrow arc extending portion **221a**, and a wide end opening portion **222a** located at one end of the arc opening **22**, that is, the radial dimension of the end opening portion **222a** is larger than that of the arc extending portion **221a**. The radial (width) dimension of the opening portion **222a** is designed to allow the thick end **212a** of the protrusion **21** to pass therethrough, while the radial (width) dimension of the arc extending portion **221a** is designed to prevent the thick end **212a** from passing therethrough, so that when the end covers of two spring modules face with each other, a pair of protrusions **21** of one end cover may pass through a pair of end opening portions **222a** of the other end cover, at the same time, a pair of protrusions **21** of the other end cover may pass through a pair of end opening portions **222a** of the one end cover, by rotating the two spring modules along a locking direction, the base portion **211a** of each protrusion **21** moves into the arc extending portion **221a** of which along the corresponding arc opening **22** and is locked into the narrow arc extending portion **221a** through the thick end **212a** of each protrusion, thereby fixing the two spring modules together in an end cover-to-end cover manner, as shown in the figures.

[0292] FIG. 28F is a partial enlarged view of FIG. 28E, showing an optional interlocking device provided on the end cover, which comprises a pair of arc walls **23** and a pair of uprights **24** arranged on the end cover in a central symmetrical manner along the circumferential direction of the end cover, the arc walls **23** and the uprights **24** are alternately arranged mutually along the circumferential direction of the end cover. Corresponding to the interlocking device, the base portions **211a** of the protrusions **21** of the rotary fixing device of in the height direction of the spring modules are sized to allow the two spring modules to move a certain

distance relative to each other along the height direction of the spring modules when fixing together in an end cover-to-end cover manner, the distance is designed to be larger than the dimension of the uprights **24** in the height direction of the spring modules, so that when rotating the two spring modules along the locking direction, the arc walls **23** of one spring module are allowed to pass over the uprights **24** of the other spring module. When the two spring modules are already locked in an end cover-to-end cover manner, the uprights **24** of one spring module engage one end of the arc walls **23** of the other spring module to prevent the two spring modules from rotating relative to each other in an unlocking direction opposite to the locking direction, as shown in FIG. **28F**. When requiring disassembly, the two spring modules may be moved away from each other manually thus disengaging the arc walls **23** from the uprights **24**, and then, the two spring modules may be rotated in the unlocking direction. Preferably, the interlocking devices **23**, **24** are positioned radially outside the rotary fixing device **21**, **22**.

[**0293**] FIGS. **29A** and **29B** show a spring module having locking structures **31**, **32** adapted in shape according to a preferred embodiment of the present disclosure, which are arranged on four sides of the base of the spring module and comprise convex parts **31** extending outward perpendicular to the corresponding sides in the horizontal direction of the base and concave parts **32** extending inward perpendicular to the corresponding sides in the horizontal direction of the base. The convex parts **31** and the concave parts **32** are mutually arranged in alternation on the sides of the base, and the convex parts **31** and the concave parts **32** are shaped to be adapted mutually, so that the convex parts **31** and the concave parts **32** of one spring module may respectively insert into and receive the corresponding concave parts **32** and the corresponding convex parts **31** of another adjacent spring module in the direction perpendicular to the plane of the base, thereby limiting relative movement between adjacent spring modules in the horizontal direction. The convex part **31** comprises a neck and a head positioned at the end of the neck and wider than which. The concave part **32** comprises an opening part and an enlarged concave part positioned inside the opening part and wider than which, and the shapes of the opening part as well as the enlarged concave part are respectively adapted to the neck as well as the head of the convex part, so that the convex part **31** and the concave part **32** of one spring module may respectively insert into and receive the corresponding concave part and the corresponding convex part of another adjacent spring module in the direction perpendicular to the surface of the base.

[**0294**] Preferably, each convex part **31** further comprises a slider **311a** and a spring member **312a**. The slider **311a** is configured to slide outward and inward along the horizontal direction of the base perpendicular to the corresponding side in the convex part **31**, and the outer side of the slider **311a** is provided with an outwardly protruding tongue part **3111a**. One end of the spring member **312a** is fixed on the base while the other end of which is a free end, the spring member **312a** passes through the slider **311a** and fixes which between the fixed end and the free end of the spring member **312a**, the spring member **312a** is used to apply elasticity to the slider allowing it to slide outward. Two limiting members **313a**, **314a** are provided on the base for limiting the movement range of the free end of the spring member **312a**, wherein the first limiting member **313a** is used to limit the

free end of the spring member **312a** in a first position so that the slider is in a retracted position, and the second limiting member **314a** is used to limit the free end of the spring member **312a** in a second position so that the slider is in an extended position. A groove **322a** for accommodating the tongue part **3111a** of the slider in the extended position is provided in each concave part **32** so as to limit relative movement along the height (vertical) direction between the adjacent spring modules. Preferably, the edges of each concave part **32** on the upper and lower surfaces of the base are further provided with a guiding inclined surface **321a** for guiding the tongue part **3111a** into the concave part **32**. FIG. **29C** exemplarily shows a condition when a plurality of spring modules are interlocked together through the interlocking device shown in FIGS. **29A**, **29B**, as can be seen from the figures, the convex parts **31** of each spring module are adapted within the concave parts **32** of the adjacent spring module, and the slider **311a** is in an extended position so that the tongue part **311a** is inserted into the groove **322a**.

[**0295**] FIGS. **30A** and **30B** show a spring module having locking structures **41**, **42** adapted in shape according to another preferred embodiment of the present disclosure, wherein the convex parts **41** and the concave parts **42** are mutually arranged in alternation on four sides of the base. As shown in the figures, the spring module comprises locking structures provided on four sides of the base, and the locking structure comprises a convex part **41** extending outward perpendicular to the corresponding side along the horizontal direction of the base and a concave part **42** extending inward perpendicular to the corresponding side in the horizontal direction of the base. The shape of the convex part **41** and the shape of the concave part **42** are mutually adapted or complementary, so that the convex part **41** of one spring module may be inserted into the concave part **42** of another spring module in the horizontal direction. Preferably, the convex part **41** and the concave part **42** are substantially triangular. Further preferably, a boss **411a** is provided on the upper surface and/or the lower surface of the convex part **41**, and a through hole **421a** is provided in the upper wall and/or the lower wall of the concave part **42**, and the boss **411a** may enter into and exit from the through hole **421a** of the concave part of another spring module. FIG. **30C** exemplarily shows a condition when a plurality of spring modules are combined together through the locking structures shown in FIGS. **30A** and **30B**, since the locking structure on each side of the base of the spring module is the same, thereby allowing various splicing.

[**0296**] FIG. **30D** shows a spring module having locking structures adapted in shape according to yet another preferred embodiment of the present disclosure. As shown in the figure, the spring module comprises locking structures provided on four sides of the base, the locking structure comprises a convex part **43** extending outward perpendicular to the corresponding side in the horizontal direction of the base, and a concave part **44** extending inward perpendicular to the corresponding side in the horizontal direction of the base, the convex parts **43** and the concave parts **44** are arranged opposite to each other on four sides of the base, for example, one side of the base is provided with a pair of convex parts **43**, and another side of the base opposite to said side is provided with a pair of concave parts **44**, as shown in the figure. The shape of the convex part **43** and the concave part **44** are mutually adapted or complementary, so that the convex part **43** of one spring module may be inserted

into the concave part **44** of another spring module in the horizontal direction. Preferably, the convex part **43** and the concave part **44** are substantially triangular. Further preferably, a boss **431a** is provided on the upper surface and/or the lower surface of the convex part **43**, and a through hole **441a** is provided in the upper wall and/or the lower wall of the concave part **44**, and the boss **431a** may enter into and exit from the through hole **441a** of the concave part of another spring module. FIGS. **30E** and **30F** exemplarily show two conditions when a plurality of spring modules are combined together through the locking structures shown in FIGS. **30C** and **30I**).

[0297] FIGS. **31A** and **31B** show a spring module having a T-shaped (or wedge-shaped) connection according to a preferred embodiment of the present disclosure. As shown in the figures, one or more sides of the base of the spring module are provided with a T-shaped (or wedge-shaped) connection **51** extending along the corresponding side, and the T-shaped connection **51** comprises a first flange **511a** extending upward along the height direction of the spring module, and a second flange **511b** extending downward along the height direction of the spring module, when two T-shaped connections **51** of two spring modules are arranged adjacently, the two T-shaped connections **51** may be connected together by a connector **52** (as seen in FIGS. **31C** and **31I**) having a pair of upper flanges **521a** extending downward as well as a pair of lower flanges **521b** extending upward, and the connector **52** may slide along the first flange **511a** as well as the second flange **511b** so as to pass between two spring modules arranged side by side and connect them together. As shown in FIG. **31C**, the connector **52** comprise: an intermediate wall; a pair of upper flanges **521a** extending downward as well as a pair of lower flanges **521b** extending upward positioned at both sides of the intermediate wall which may pass between two adjacently arranged connections **51** of two adjacently arranged spring modules so as to connect the two adjacently arranged spring modules together through the upper flanges **521a** as well as the lower flanges **521b**. The upper flange **521a** and the lower flange **521b** of the connection **52** on the same side of the intermediate wall form a slideway in which the first flange **511a** and the second flange **511b** of the spring module may slide through. Preferably, the slideway may be wedge-shaped, and the first flange **511a** as well as the second flange **511b** may form a wedge-shaped shape adapted to the wedge-shaped shape of the slideway. FIG. **31D** exemplarily shows a condition when the spring modules having the T-shaped connections **51** shown in FIGS. **31A** and **31B** are connected in rows through the I-shaped connectors shown in FIG. **31C**.

[0298] FIG. **31E** shows a spring module having a T-shaped (or wedge-shaped) connection **51** according to another preferred embodiment of the present disclosure. As shown in the figure, four sides of the base of the spring module with multiple springs (the spring module shown in the figure comprises four springs, which may also comprise any other number of springs, such as three, five, etc.) are all provided with T-shaped connections **51**, and a stop part **511c** for limiting the I-shaped connector **52** is provided in the middle of the second flange **511b** in order to prevent the I-shaped connector **52** from sliding further inward.

[0299] FIGS. **31G** and **31H** exemplarily show a condition when a plurality of spring modules shown in FIG. **31E** (springs omitted) are connected together through the I-shaped connectors shown in FIG. **31F**, wherein a three-in-

one spring module (three springs installed in one one-piece spring bracket) and a four-in-one spring module (four springs installed in one one-piece spring bracket) are shown, those skilled in the art will realize that the spring module may also be a spring module containing other numbers of springs. Any number of spring modules may be spliced together in any way according to actual requirements (such as the size of the spring cushion).

[0300] FIGS. **31L** and **31M** exemplarily show spring cushions of different sizes which are made by splicing the spring modules and the I-shaped connectors shown in FIG. **31E-31H**, because four sides of the base of the spring module of the present embodiment are all provided with T-shaped (or wedge-shaped) connections **51**, the spring modules arranged adjacently in the transverse and longitudinal directions are connected together through the I-shaped connectors **52**.

[0301] FIGS. **31I** and **31J** show a spring module having wedge-shaped (or T-shaped) splicing parts **53**, **54** according to a preferred embodiment of the present disclosure. As shown in the figures, one side of the base is provided with a wedge-shaped (or I-shaped) groove **54**, and the opposite side is provided with a wedge-shaped (or T-shaped) protrusion **55** capable of shape matching with the wedge-shaped (or T-shaped) groove **54**, the other two opposite sides are respectively provided with wedge-shaped protrusions **53**, the wedge-shaped protrusion **55** may slide within the wedge-shaped groove **54** of the base of another spring module so as to connect the two spring modules together, and the wedge-shaped protrusion **53** of one spring module may be connected together with the wedge-shaped protrusion **53** of another spring module by the I-shaped connector **52** shown in FIG. **31F**. Preferably, the two side walls **541a**, **541b** forming the wedge-shaped grooves **54** are discontinuous, and the side walls **541a**, **541b** are distributed in a staggered manner. FIG. **31K** exemplarily shows an enlarged sectional view when two spring modules shown in FIGS. **31I** and **31J** are spliced together through the wedge-shaped protrusions **55** and the wedge-shaped grooves **54**.

[0302] FIGS. **31N** and **31P** exemplarily show spring cushions of different sizes assembled by the spring modules shown in FIGS. **31I-31K** and the I-shaped connectors shown in FIG. **31F**, as shown in the figures, because one pair of opposite sides of the base of the spring module of the present embodiment are respectively provided with the wedge-shaped grooves **54** and the wedge-shaped protrusions **55** which may be matched with each other, and further, the other pair of opposite sides are respectively provided with the T-shaped (or wedge-shaped) connections **53**, transversely (the horizontal direction shown in the figures) adjacent spring modules are connected with each other by the I-shaped connectors **52**, while longitudinally (the vertical direction shown in the figures) adjacent spring modules are connected with each other by their own wedge-shaped grooves **54** and wedge-shaped protrusions **55**.

[0303] FIG. **32A** shows a spring module according to a preferred embodiment of the present disclosure in which the base and the end cover may be snapped together so that the spring is compressed therebetween, the volume of the spring module is greatly reduced when the base and the end cover are snapped together, thus convenient for storage and transportation. FIGS. **32B-32D** respectively illustrate a perspective view, a top view and a side view of the base of the spring module shown in FIG. **32A**, and FIGS. **32E**, **32F** respectively illustrate a perspective view and a top view of the end

cover of the spring module shown in FIG. 32A. As shown in the figures, the spring module comprises a spring 110e and a spring bracket 120a capable of holding and fixing the spring, and the spring bracket 120a comprises a base 121a, an end cover 122a and flexible connecting straps 123a. The base 121a comprises a spring mounting seat having first spring fixing parts 1212a, each of which may be configured to fix a first end of the spring 111e. The end cover 122a comprises a spring mounting seat having second spring fixing parts 1222a capable of fixing a second end of the spring. Two ends of each flexible connecting strap 123a are fixedly connected to the base 121a and the end cover 122a, respectively, and are positioned outside each spring 110e. A rotary locking assembly is provided on the base 121a as well as the end cover 122a, and the base is configured to be removably locked together with the end cover through the rotary locking assembly, so that the spring is compressed therebetween. As shown in FIGS. 32B-32F, the rotary locking assembly comprises one or more locking posts 127a provided on the outer region of the base 121a, and one or more arc openings 128a provided on the corresponding outer region of the end cover 122a. Each locking post 127a comprises a base 1271a as well as an end 1272a having a larger sectional size than that of the base. Each arc opening 128a comprises an arc extending portion 1281a and an end opening portion 1282a positioned at one end of the arc opening and larger in size than the arc extending portion. The end opening portion 1282a of each arc opening 128a is sized to allow the thicker end 1272a of the corresponding locking post 127a to pass therethrough, and the narrower arc extending portion of each arc opening 128a is sized not to allow the end 1272a of the corresponding locking post 127a to pass therethrough, therefore, when compressing the spring and rendering the thick end of each locking post 127a to pass through the corresponding end opening portion 1282a, by rotating the base 121a and the end cover 122a along the locking direction, the base 1271a of each locking post 127a moves along the corresponding arc opening 128a into the arc extending portion 1281a of which and is locked therein by the end 1272a, thereby releasably locking the base and the end cover together. FIGS. 32G and 32H schematically respectively show a perspective view and a top view when the base and the end cover of the spring module shown in FIG. 32A are snapped together. FIG. 32I exemplarily shows a condition when a plurality of spring modules shown in FIGS. 32G and 32H are stacked together, wherein the spring modules are in a compressed configuration. The compressed and locked spring modules may greatly save space for storage and transportation.

[0304] FIGS. 32J and 32K exemplarily show spring modules with the base and the end cover of which can be snapped together according to another preferred embodiments of the present disclosure, respectively, wherein the flexible connecting part of the spring module shown in FIG. 32J is composed of flexible ropes 123b, and the flexible connecting part of the spring module shown in FIG. 32K is a one-piece flexible sleeve 123c surrounding the spring with 360 degrees.

[0305] FIGS. 32L and 32M exemplarily show spring modules with the base and the end cover of which can be snapped together according to other preferred embodiments of the present disclosure, respectively, wherein the spring module shown in FIG. 32L has a spring bracket 120b in which three springs can be accommodated, and the spring bracket 120b

comprises a base 121b and an end cover 122b in which three springs can be accommodated, and the spring module shown in FIG. 32M has a spring bracket 120c in which four springs can be accommodated, and the spring bracket 120c comprises a base 121c and an end cover 122c in which four springs can be accommodated. The bottom surfaces of the bases 121a, 121b and 121c of the spring modules as described above may also be provided with module mounting parts 1213a for detachably mounting the spring modules into the spring cushions. Preferably, the module mounting part 1213a is a slideway or a slide rail, so that the base of the spring module may be slidably assembled onto the mounting rack in the spring cushion. Furthermore, the spring brackets 120a, 120b and 120c may be integrally formed. More preferably, the spring is installed in the spring bracket with a predetermined initial compression force. Alternatively, the base may be provided with an opening 1211a, at the center of which, and the end cover may be provided with an opening 1221a at the center of which.

[0306] FIGS. 33A-33F exemplarily show a spring module as well as its components according to another preferred embodiment of the present disclosure, in which a base and an end cover can be snapped together. As shown in the figures, the spring module comprises a base 121d, an end cover 122d and a spring bag. The base 121d comprises a pair of first locking mechanisms 1211d provided at the periphery of which, and the end cover 122d comprises a pair of second locking mechanisms 1221d provided at the periphery of which. The spring bag is removably fixed between the base 121d and the end cover 122d, each spring bag comprises a spring 110f and a flexible sleeve 123d encompassing the spring. The base 121d and the end cover 122d may be releasably snapped together by the first locking mechanism 1211d and the second locking mechanism 1221d to compress the spring bag between the base and the end cover. Preferably, the spring is enclosed in the flexible sleeve 123d with a predetermined initial compression force. Although the spring shown in the figures is a convex spring with a convex center, those skilled in the art may realize that the spring may also be a cylindrical spring or a concave spring with a concave center. The locking mechanisms 1211d, 1221d will be described in detail below with reference to FIGS. 33E-33G, as shown in the figures, the pair of first locking mechanisms 1211d extend outward from the base 121d along the radial direction, and each first locking mechanism comprises a first protrusion 12112d located between the first locking mechanism 1211d and the base 121d. The pair of second locking mechanisms 1221d extend outward from the end cover 122d along the radial direction, and each second locking mechanism comprises a spring tongue part 12211d capable of moving toward and away from the end cover 122d, and a second protrusion 12212d located outside the tongue part. And the second protrusion 12212d may engage with the first protrusion 12112d so as to lock the base with the end cover. The second protrusion 12212d may be disengaged from the first protrusion 12112d as the tongue part 12211d moves toward the end cover, thereby releasing the end cover from the base. Preferably, each first locking mechanism 1211d further comprises a notch 12111d, which is located in the middle of the first locking mechanism, so that a user may press the tongue part 12211d toward the end cover through the notch 12111d thus releasing the end cover.

[0307] FIG. 33H exemplarily shows a spring module according to another preferred embodiment of the present disclosure in which the base and the end cover can be locked together, and FIG. 33I shows the compressed configuration of the spring module, as shown in the figures, unlike the spring module shown in FIGS. 33A-33G, the spring module comprises a base 121e and an end cover 122e in which four spring bags can be accommodated. Similarly, the base 121e comprises a pair of first locking mechanisms 1211e provided at the periphery of which and the end cover 122e comprises a pair of second locking mechanisms 1221e provided at the periphery of which. The spring bags are detachably fixed between the base 121e and the end cover 122e, and the base 121e and the end cover 122e may be releasably locked together through the first locking mechanism 1211e and the second locking mechanism 1221e so as to compress the spring bags between the base and the end cover. The first pair of locking mechanisms 1211e extend outward from the base 121e along the radial direction, and each first locking mechanism comprises a first protrusion 12112e positioned between the first locking mechanism 1211e and the base 121e. The pair of second locking mechanisms 1221e extend outward from the end cover 122e along the radial direction, and each second locking mechanism comprises a spring tongue part 1221e capable of moving toward and away from the end cover 122e, and a second protrusion 12212e positioned outside the tongue part. The second protrusion 12212e may engage with the first protrusion 12112e in order to lock the base and the end cover together. The second protrusion 12212e may be disengaged from the first protrusion 12112e as the tongue part 1221e move towards the end cover, thereby releasing the end cover from the base.

[0308] FIGS. 33I-33L exemplarily show a condition when a plurality of the spring modules shown in FIG. 33A or 33H are connected in rows through flexible bottom pads 60a, 60b and 60c, as shown in the figures, the spring modules are fixed on a first surface of the flexible bottom pad, and the flexible bottom pad may be bent to allow a first part of a second surface of which opposite to the first surface to engage with a second part of the second surface, as shown in FIGS. 33M, 33N. FIG. 33P exemplarily shows a spring cushion having the spring modules as well as the flexible bottom pads 60b or 60c shown in FIG. 33L.

[0309] FIG. 34A exemplarily shows a spring module with a base and an end cover of which may be locked together according to another preferred embodiment of the present disclosure. FIGS. 34B-34D illustrate a perspective view, a top view and a side view of the base of the spring module shown in FIG. 34A, and FIGS. 34E, 34F illustrate a perspective view and a top view of the end cover of the spring module shown in FIG. 34A, respectively. As shown in the figures, the spring module comprises a spring 110e, a base 121f and an end cover 122f. The base 121f comprises a spring mounting seat with a first spring fixing part 1212f capable of fixing a first end of the spring, and the end cover 122f comprises a spring mounting seat with a second spring fixing part 1222f capable of fixing a second end of the spring. The base and the end cover are provided with a rotary locking assembly, and the base may be releasably locked together with the end cover by the rotary locking assembly, so that the spring is compressed therebetween. Specifically, the rotary locking assembly comprises one or more locking posts 127f positioned on the outer region of the base and one or more arc openings 128f positioned on the corresponding

outer region of the end cover. Each locking post 127f comprises a thin base 1271f and a thick end 1272f. Each arc opening 128f comprises a narrow arc extending portion 1281f and a wide end opening portion 1282f, and the end opening portion 1282f is positioned at one end of the arc opening 128f. The end opening portion 1282f of each arc opening 128f is sized to allow the end 1272f of the corresponding locking post 127f to pass therethrough, while the arc extending portion 1281f of each arc opening 128f is sized not to allow the end of the corresponding locking post to pass therethrough, so that when compressing the spring and rendering the end 1272f of each locking post to pass through the corresponding end opening portion 1282f, by rotating the base and the end cover along the locking direction, the base 1271f of each locking post moves along the corresponding arc opening 128f into the arc extending portion 1281f of which and is locked in the arc extending portion 1281f through the end 1272f, thereby releasably locking the base and the end cover together. FIG. 34G exemplarily shows a condition when the base and the end cover of the spring module shown in FIG. 34A are locked together. Preferably, the base 121f further comprises a module mounting part 1213f for removably mounting the spring module into the spring cushion, and the module mounting part 1213f may be a slideway or a slide rail arranged on the bottom surface of the base, so that the base of the spring module may be slidably assembled onto the mounting rack in the spring cushion through the module mounting part 1213f. Alternatively, the base may be provided with an opening 1211f at the center of which, and the end cover may be provided with an opening 1221f at the center of which,

[0310] FIGS. 35A and 35B schematically show a perspective view and a side view, respectively, of a spring module according to yet another preferred embodiment of the present disclosure. As shown in the figures, the spring module comprises a conical spring 110 and a plurality of flexible straps 123e, each flexible strap 123e respectively comprises a main body 1231e; a first hook 1232e at one end of the main body, and a second hook 1233e at the other end of the main body. The first hook 1232e is removably hooked on the large-diameter end of the conical spring, and the second hook 1233e is removably hooked on the small-diameter end of the conical spring, and the flexible straps 123e are all positioned outside the conical spring. Preferably, the lengths of the plurality of flexible straps 123e are designed such that the conical spring has a predetermined initial compression force. Further preferably, the flexible straps 123e are integrally formed and made of plastic. Optionally, the width and/or thickness of the main body 1231e of the flexible strap 123e gradually decreases from one end to the other end.

[0311] FIGS. 35C and 35D exemplarily show a perspective view and a side view, respectively, of a spring module according to yet another preferred embodiment of the present disclosure. As shown in the figures, the spring module comprises a conical spring 110 and a plurality of flexible straps 123f and each flexible strap 123f comprises a main body 1231f; a first hook 1232f positioned at one end of the main body; and a second hook 1233f positioned at the other end of the main body. The first hook 1232f is hooked on the large-diameter end of the conical spring, the second hook 1233f is hooked on the small-diameter end of the conical spring, and the flexible straps 123f are all positioned outside the conical spring. The lengths of the plurality of flexible straps 123f are preferably designed such that the conical

spring has a predetermined initial compression force. Further preferably, the main body **1231f** of the flexible strap **123f** is made of woven fabric, and the first hook **1231f** as well as the second hook **1232f** of the flexible straps **123f** are made of metal or plastic. Optionally, the width and/or thickness of the main body **1231e** of the flexible straps **123e** gradually decreases from one end to the other.

[0312] FIG. 35E exemplarily shows a condition when the plurality of spring modules shown in FIGS. 35A to 35D are nested together.

[0313] FIGS. 35F and 35G exemplarily show an exploded view and a sectional view of a spring module, respectively, according to yet another preferred embodiment of the present disclosure, and FIG. 35H is a partial enlarged view of FIG. 35G. As shown in the figures, the spring module comprises a conical spring **110**, a one-piece flexible sleeve **1231g** having a closed end and an open end, and one or more fasteners **129g**. The conical spring **110** passes through the open end of the one-piece flexible sleeve **1231g** and enters the interior of which, so that the one-piece flexible sleeve encompasses outside the conical spring, and wherein the end of the open end of the one-piece flexible sleeve **1231g** is bent around the large-diameter end of the conical spring **110** toward the interior of the conical spring and fixed to an adjacent part of the one-piece flexible sleeve **1231g** positioned outside the conical spring **110** by one or more fasteners **129g** (as shown in FIG. 35H). Preferably, the one-piece flexible sleeve **1231g** and the one or more fasteners **129g** cooperate with each other so that the conical spring may have a predetermined initial compression force. In a preferred embodiment, the one-piece flexible sleeve **1231g** is a one-piece cloth sleeve, and the fastener **129g** is a rivet. FIG. 35I exemplarily shows a condition when a plurality of spring modules shown in FIGS. 35F and 35G are nested together.

[0314] FIG. 35J exemplarily shows a spring module according to another preferred embodiment of the present disclosure, and FIG. 35K shows a conical spring **110b** of which. Unlike the spring module shown in FIGS. 35F-35H, the flexible sleeve **12310** as well as the conical spring **110b** are square conical.

[0315] FIGS. 36A and 36B exemplarily show a perspective view and a perspective view of a spring module according to yet another preferred embodiment of the present disclosure, which comprises a plurality of connected cylindrical cloth sleeves **1231i** in rows and a plurality of cylindrical springs encompassed therein. FIG. 36C exemplarily shows a perspective view of a spring module according to another preferred embodiment of the present disclosure, FIG. 36D exemplarily shows a condition when the spring module shown in FIG. 36C is compressed and stored in a storage box, and FIG. 36E exemplarily shows a condition when a plurality of storage boxes shown in FIG. 36D are stacked together.

[0316] FIG. 37 exemplarily shows a perspective view of a spring module according to yet another preferred embodiment of the present disclosure. As shown in the figure, the spring module comprises a conical spring **110**, a base **121j** and a plurality of flexible straps **123j**. The base has a spring mounting seat with a spring fixing part **1212j** for fixing the large-diameter end of the conical spring, one end of each flexible strap **123j** is fixedly coupled to the base, while the other end has a hook part **1233j** which is detachably hooked on the small-diameter end of the conical spring, and the

plurality of the flexible straps **123j** are all positioned outside the conical spring **110**. Preferably, the lengths of the plurality of flexible straps **123j** are designed such that the conical spring **110** has a predetermined initial compression force. Further preferably, the flexible strap **123j** is entirely made of plastic. Optionally, the main body of the flexible strap **123j** is made of woven fabric, and the hook part **1233j** is made of metal or plastic. Optionally, the width and/or thickness of the main body of the flexible strap **123j** gradually decreases from one end to the other end. In a preferred embodiment, the bottom surface of the base **121j** is further provided with a module mounting part **1213j** for removably mounting the spring module into a spring cushion. Preferably, the module mounting part **1213j** may be slideways or slide rails arranged on the bottom surface of the base, so that the base can be slidably assembled to the mounting rack in the spring cushion through the module mounting part **1213j**. In another preferred embodiment, the base **121j** may also be provided with locking structures **31** and **32** shown in FIGS. 29A-29C, locking structures **41**, **42** shown in FIGS. 30A-30C, locking structures **43**, **44** shown in FIGS. 30D-30F, or T-shaped (or wedge-shaped) connections **51** shown in FIGS. 31A-31D.

[0317] FIGS. 38A, 38B exemplarily show a perspective exploded view and a perspective sectional view of a spring module (spring bag) according to yet another preferred embodiment of the present disclosure, respectively. As shown in the figures, the spring module (spring bag) comprises a conical spring **110** and a double-layer flexible sleeve, the double-layer flexible sleeve comprises: a frustoconical outer layer **123m** having a closed end and an open end, and the open end of the frustoconical outer layer is provided with a first flange **1231m** extending outward; and a frustoconical inner layer **123n** positioned inside the frustoconical outer layer **123m**, wherein the frustoconical inner layer **123n** has a closed end and an open end, and the open end of the frustoconical inner layer **123n** is provided with a second flange **1231n** extending outward. The radial dimension of the frustoconical inner layer **123n** is smaller than that of the frustoconical outer layer **123m**, and the height dimension of the frustoconical inner layer **123n** is approximately equal to that of the frustoconical outer layer **123m**, the conical spring **110** is positioned between the frustoconical outer layer **123m** and the frustoconical inner layer **123n**. The first flange **1231m** of the frustoconical outer layer **123m** is fixedly coupled with the second flange **1231n** of the frustoconical inner layer **123n**, and the closed end of the frustoconical outer layer is fixedly coupled with the closed end of the frustoconical inner layer. Preferably, the height dimension of the frustoconical outer layer **123m** and that of the frustoconical inner layer **123n** are designed to allow the conical spring therebetween to have a predetermined initial compression force. Preferably, the frustoconical outer layer **123m** and the frustoconical inner layer **123n** are coupled together by adhesive or ultrasonic welding.

[0318] FIGS. 39A, 39B respectively illustrate conditions when the spring bag shown in FIGS. 38A, 38B are fixed on the base through different fixing ways, the spring bag is fixedly coupled to the base through an engaging part on the base in FIG. 39A, while in FIG. 39B the spring bag is fixedly coupled to the base through fasteners. FIG. 39C exemplarily shows a condition when a plurality of spring modules shown in FIG. 39A or 39B are nested together. The base may be provided with locking structures **31** and **32** shown in FIGS. 29A-29C, locking structures **41** and **42** shown in FIGS.

30A-30C, locking structures 43 and 44 shown in FIGS. 30D-30F, or T-shaped (or wedge-shaped) connections 51 shown in FIGS. 31A-31D.

[0319] FIGS. 40A-40C exemplarily show different embodiments of non-conical springs that can be used in the above-mentioned spring module, and FIG. 40D exemplarily shows a spring module having the spring shown in FIG. 40B. FIG. 40E exemplarily shows a different embodiment of a conical spring that can be used in the above-mentioned spring module, and FIG. 40F exemplarily shows a spring module 200a comprising the conical spring shown in FIG. 40E, which comprises a spring bracket 220a and a square conical spring 110b installed therein.

[0320] FIG. 40G exemplarily shows a different embodiment of a conical spring that can be used in the spring module of the present disclosure, wherein at least a part of the conical spring is formed by a double spiral wire, and preferably, a double-wire spring part with the double spiral wire occupies about $\frac{2}{3}$ of the overall height of the conical spring. FIG. 40H exemplarily shows a spring module comprising the conical spring shown in FIG. 40G.

[0321] On the other hand, the present disclosure also provides a spring cushion comprising various spring modules as described above.

[0322] FIG. 41A exemplarily shows a spring cushion according to a preferred embodiment of the present disclosure. As shown in the figure, the spring cushion comprises various spring modules described in the above embodiments; a first sponge pad 1300a, each having a plurality of holes, each hole being configured such that a part of the corresponding spring module may pass therethrough; a second sponge pad 1100a sleeved on the first sponge pad 1300a; an outer cover 1200a sleeved on the second sponge pad 1100a so as to wrap the spring module, the first sponge pad as well as the second sponge pad therein.

[0323] FIG. 41B exemplarily shows a spring cushion according to another preferred embodiment of the present disclosure, which is different from the spring cushion shown in FIG. 41A in that a first sponge pad 1300b comprises a plurality of separate parts arranged side by side, wherein each separate part may have different stiffness and color, so as to be arranged at different positions of the mattress as required and be easy to distinguish, as shown in FIG. 41C.

[0324] FIG. 41D exemplarily shows a spring cushion according to yet another preferred embodiment of the present disclosure. As shown in the figure, the spring cushion is different from the spring cushions shown in FIGS. 41A, 41B in that it further comprises a fixing net 1400a having a plurality of ring parts, each of which is configured to allow a part of the corresponding spring module to pass therethrough. When the fixing net 1400a is arranged on the spring module, the vertical distance between the ring part and the top of the spring module is about $\frac{1}{3}$ of the overall height of the spring module.

[0325] FIG. 42A exemplarily shows a fixing net assembly 1400b for a spring cushion according to a preferred embodiment of the present disclosure, and FIG. 42B exemplarily shows a partial sectional view of the fixing net assembly shown in FIG. 42A. As shown in the figures, the fixing net assembly 1400b comprises a flexible sheet 1410b having a plurality of holes, and a plurality of caps 1420b, wherein the holes of the flexible sheet 1410b are positioned corresponding to the positions of the spring modules, and each cap 1420b comprises a cavity 1421b for accommodating the top

end part of the spring module and a flange 1422b surrounding the cavity, wherein, the wall forming the cavity 1421b is sized to be smaller than the hole so as to enable the wall to pass therethrough, and the flange 1422b is sized to be larger than the hole so as to enable the flange to engage with part of the flexible sheet around the hole, and wherein the flange 1422b is fixedly coupled to the part of the flexible sheet around the hole by adhesive or ultrasonic welding, and the cavity 1421b may accommodate the top of the spring module.

[0326] FIG. 42C exemplarily shows an exploded view of a fixing net assembly 1400c for a spring cushion according to a preferred embodiment of the present disclosure, as shown in the figure, the fixing net assembly 1400c comprises a flexible sheet 1410c without holes; a plurality of upper caps 1420c or 1420d located on one side of the flexible sheet, each of which is provided with a first snap feature 1422c or 1422d; a plurality of lower caps 1430c or 1430d located on the other side of the flexible sheet, each of which is provided with a second snap feature 1432c or 1432d. The first snap feature of the upper cap is configured to snap fit with the second snap feature of the lower cap and clamp the flexible sheet therebetween, and the lower cap 1430c and 1430d may accommodate the top of the spring module.

[0327] FIGS. 42D, 42E exemplarily show a process in which the upper cap 1420c and the lower cap 1430c are clamped on the flexible sheet 1410c, as shown in the figures, the upper cap 1420c has an annular wall 1421c and an annular protrusion 1422c located outside the annular wall 1421c, while the lower cap 1430c has a circular hole 1431c, and the annular protrusion 1422c may be locked on the edge 1432c of the circular hole 1431c so as to clamp the flexible sheet 1410c therebetween.

[0328] FIGS. 42F and 42G exemplarily show a process in which the upper cap 1420d and the lower cap 1430d are clamped on the flexible sheet 1410c, as shown in the figures, different from the above-mentioned caps 1420c and 1430c, the inner and outer sides of the annular wall of the upper cap 1420d are all provided with annular protrusions 1422d, and the lower cap 1430d is provided with an annular groove 1431d, in which an snap-fit part 1432d is provided, and the annular protrusions 1422d may be locked with the snap-fit part 1432d in the annular groove 1431d so as to clamp the flexible sheet 1410c therebetween.

[0329] FIG. 42H exemplarily shows a spring cushion according to yet another preferred embodiment of the present disclosure, and FIG. 42I exemplarily shows a sectional view of the spring cushion. As shown in the figures, the spring cushion comprises various spring module assemblies shown in the above embodiments, especially in FIGS. 33J-33N. The spring cushion of the present embodiment further comprises a spring pad 1500a spread on the spring module assemblies, and an outer cover 1600a having a quilted sponge layer, which covers the spring pad 1500a and wraps the spring module assemblies as well as the spring pad 1500a.

[0330] Furthermore, FIG. 42L exemplarily shows the foregoing spring pad 1500a, and FIG. 42M exemplarily shows a partial sectional view of the spring pad 1500a. As shown in the figures, the spring pad 1500a comprises: a plurality of cylindrical springs 1530a, a first non-woven fabric layer 1510a located at one side of the plurality of cylindrical springs 1530a, and a second non-woven fabric layer 1520a at the other side of the plurality of cylindrical springs 1530a.

The first non-woven fabric layer **1510a** and the second non-woven fabric layer **1520a** are coupled together around each cylindrical spring **1530a** by adhesive or ultrasonic welding, so as to separate adjacent cylindrical springs and fix the cylindrical springs between the two non-woven fabric layers thus forming a one-piece spring pad. In other words, the first non-woven fabric layer **1510a** and the second non-woven fabric layer **1520a** are coupled together around each small cylindrical spring **1530a** by adhesive or ultrasonic welding so as to form compartments for accommodating the plurality of small cylindrical springs, such that the adjacent small cylindrical springs may be separated mutually. The elastic coefficient of the cylindrical spring **1530a** is preferably smaller than that of the spring in the spring module positioned at the bottom layer, thus providing stiffness close to sponge. Furthermore, the plurality of cylindrical springs **1530a** are preferably denser than the plurality of spring modules positioned at the bottom layer so as to provide better comfort. In other words, the radial dimension of the cylindrical springs **1530a** is preferably smaller than that of the springs in the spring modules, and the number of the cylindrical springs **1530a** is preferably larger than that of the spring modules. The spring pad **1500a** may be used to replace the sponge pad, and is comfortable, air-permeable and cost-saving.

[0331] FIG. 42J exemplarily shows a spring cushion according to yet another preferred embodiment of the present disclosure, and FIG. 42K exemplarily shows a sectional view of the spring cushion. As shown in the figures, the spring cushion comprises various spring modules or spring module assemblies shown in the above embodiments, especially in FIGS. 29A-31P. The spring cushion of the present embodiment further comprises a spring pad **1500a** spread on the spring module assemblies, and an outer cover **1600a** having a quilted sponge layer, which covers the spring pad **1500a** and wraps the spring module assemblies as well as the spring pad **1500a**. Unlike the spring cushion shown in FIGS. 42H, 42I, the spring cushion of the present embodiment further comprises a fixing net assembly **1400b** or **1400c** shown in FIGS. 42A-42G. The fixing net assembly **1400b** or **1400c** is provided between the spring modules and the spring pad **1500a**.

[0332] FIG. 42N exemplarily shows a spring cushion according to yet another preferred embodiment of the present disclosure. Unlike the embodiment shown in FIGS. 42J and 42K, in the present embodiment, the sponge pad **1300a** shown in FIG. 41A is used instead of the fixing net assembly **1400b** or **1400c**. As described above, the sponge pad **1300a** has a plurality of holes, each hole configured to allow part of the corresponding spring module to pass therethrough. Similarly, the sponge pad **1300a** may also be replaced by the sponge pad **1300b** having the plurality of separate parts arranged side by side as shown in FIGS. 41B and 41C.

[0333] FIG. 42P exemplarily shows a spring cushion according to yet another preferred embodiment of the present disclosure, which comprises the above-mentioned spring pad **1500a** and an outer cover **1700a** covering the outside of the spring pad **1500a**. As shown in the figure, the outer cover **1700a** has a quilted sponge layer **1710a** which is positioned on the upper side and the lower side of the spring pad **1500a**. As described above, since the elastic coefficient of the spring in the spring pad **1500a** is low, the spring cushion may be

rolled up in a compressed state to save the storage space, the process of compression as well as rolling up is shown in FIG. 42Q.

[0334] FIG. 43A exemplarily shows a spring cushion according to yet another preferred embodiment of the present disclosure. As shown in the figure, the spring cushion comprises: a base cloth **1200d**; a first outer cover **1300d**, a bottom end of the first outer cover being open and a top end being closed, and an edge of the bottom end of the first outer cover **1300d** is sewn together with an edge of the base cloth **1200d** so as to form a closed accommodating space; a plurality of spring modules described in the above embodiments, each spring module comprising a spring bracket and a spring installed in the spring bracket, and the plurality of spring modules are arranged in the accommodating space; a plurality of sponge blocks **1400d** arranged in the accommodating space, and each sponge block is respectively arranged on the top of the corresponding spring module among the plurality of spring modules. The first outer cover **1300d** comprises a plurality of separate compartments, with one or more spring modules as well as one or more sponge blocks **1400d** respectively arranged in each compartment. The base cloth **1200d** is provided with a plurality of openings, each of which is aligned with one or more compartments of the plurality of compartments, and is provided with a curtain **1210d** and a zipper **1220d** provided on the curtain (as seen in FIG. 43D) for opening and closing each of the openings. Preferably, as shown in FIG. 43B, the spring cushion may further comprise a second outer cover **1500d** sleeved outside the first outer cover **1300d**.

[0335] FIG. 43C exemplarily shows the outer cover **1300d** having compartments in the spring cushions shown in FIGS. 43A, 43B, wherein the shape of each compartment is the same.

[0336] FIGS. 43D and 43E exemplarily show the first outer cover **1300d** sewn with the base cloth **1200d**, in FIG. 43D, the curtains **1210d** as well as the zippers **1220** of the base cloth are in an open state, each elongated opening of the base cloth is aligned with a row of compartments of the outer cover **1300d**, as can be seen from the figure. In FIG. 43E, the curtains **1210d** as well as the zippers **1220** of the base cloth are in a closed state.

[0337] FIGS. 43F-43H exemplarily show outer covers with compartments of different shapes/sizes according to different embodiments of the present disclosure, which can be used to accommodate different types of spring modules. FIG. 43I exemplarily shows an outer cover having honeycomb-shaped (hexagonal) compartments according to a preferred embodiment of the present disclosure.

[0338] FIGS. 44A-44E exemplarily show sponge blocks according to different embodiments of the present disclosure, as can be seen from the figures, in order to be used for different types of spring modules, the sponge block may be flat, or it may have protrusions or depressions.

[0339] FIG. 45A exemplarily shows a sponge block according to a preferred embodiment of the present disclosure. As shown in the figure, the sponge block **1400d** comprises a concave part **1410d** for accommodating the top of the spring module, and grooves **1420d** positioned on four sides of the concave part **1410d**, which are helpful for folding and compressing the sponge block, FIG. 45B exemplarily shows the sponge block shown in FIG. 45A in a folded/compressed state, and the folded sponge block may be stored in a storage cup as shown in FIG. 45C, The sponge

block **1400d** may also be placed in an elongated storage bag in a natural state, and the storage bag filled with the sponge blocks may be rolled up and placed in a box or packaged and fixed as shown in FIGS. **46A-46C**.

[**0340**] FIGS. **47A-47C** exemplarily show another packaging method of the sponge blocks according to the present disclosure, and each sponge block **1400d** may be compressed and stored in a single box.

[**0341**] FIGS. **48A-48F** exemplarily show a sponge block storage box and a sponge block storage method according to a preferred embodiment of the present disclosure. As shown in the figures, the sponge block storage box has a long and narrow hollow rectangular shape, and at least one end along the longitudinal direction of the sponge block storage box is provided with an opening **2010d** for inserting the sponge block **1400d** therethrough. The lateral wall of the sponge block storage box may be opened integrally to form a storage box cover **2020d** for taking out the sponge block **1400d** stored therein. A flange **2030d** is provided around the opening **2010d** for engaging with the periphery of the sponge block **1400d** accommodated therein so as to prevent which from exiting the storage box from the opening **2010d**. Optionally, the other end along the longitudinal direction of the sponge block storage box may also be provided with an opening.

[**0342**] FIGS. **49A, 49B** exemplarily show an outer cover **2000d** used for a spring cushion, according to a preferred embodiment of the present disclosure, the outer cover **2000d** is provided with an open bottom end (shown as an upper end in the figures) and a closed top end (shown as a bottom end in the figures), and the outer cover **2000d** comprises: a top part **2100d** having four edges **2110d**; and four side parts **2200d**, each side part of the four side parts **2200d** being sewn to a corresponding edge of the four edges **2110d** of the top part **2100d**, and mutually adjacent edges of every two adjacent side parts **2200d** being provided with zippers **2210d**, so as to detachably connecting the edges mutually adjacent of the side parts **2200d** together to partially wrap the spring modules. Preferably, the top part **2100d** sequentially comprises a non-woven fabric layer, a high-elastic sponge layer, a non-woven fabric layer, a quilted sponge layer, a silk floss layer and a cloth layer, from an inner side to an outer side of the spring cushion; each side part **2200d** sequentially comprises a non-woven fabric layer; a quilted sponge layer, a silk floss layer and a cloth layer, from the inner side to the outer side of the spring cushion.

[**0343**] Preferably, each side part **2200d** comprises a hem part **2300d** sewn with d each hem part only comprises a cloth layer.

[**0344**] In a preferred embodiment, the spring cushion further comprises one or more pairs of tethers **2400d** arranged on the hem parts **2200d** for fastening the outer cover to the plurality of spring modules.

[**0345**] FIGS. **50A, 50B** exemplarily show an outer cover for a spring cushion, according to another preferred embodiment of the present disclosure. As shown in the figures, the outer cover **3000d** is a closed outer cover and comprises: a top part **3100d**; four side parts **3210d, 3220d, 3230d** and **3240d**; and a bottom part **3300d**. The first edge of the top part **3100d** is sewn to the first side part **3210d**, the second edge of the top part opposite to its first edge is sewn to the second side part **3220d**, the first edge of the bottom part **3300d** is sewn to the first side part **3210d**, and two edges perpendicular to the first edge of the bottom part **3300d** are

respectively sewn to the third side part **3230d** and the fourth side part **3240d**, wherein zippers **3400d** are provided at all non-sewn edges of the top part **3100d**, the four side parts **3210d, 3220d, 3230d, 3240d**, and the bottom part **3300d**, in order to detachably connect the non-sewn edges together to wrap a plurality of spring modules. Preferably, the top part **3100d** sequentially comprises a non-woven fabric layer, a high-elastic sponge layer, a non-woven fabric layer, a quilted sponge layer, a silk floss layer and a cloth layer from the inner side to the outer side of the spring cushion, and the lateral parts **3210d, 3220d, 3230d** and **3240d** sequentially comprise non-woven fabric layers, quilted sponge layers, silk floss layers and cloth layers from the inner side to the outer side of the spring cushion; and the bottom part **3300d** only comprises a cloth layer.

[**0346**] FIGS. **51A-51C** show the structures of different parts of the spring cushion outer covers, marked by "AA", "BB" and "CC" in FIGS. **49A, 49B** and **50A, 50B**, respectively.

[**0347**] Those skilled in the art may realize that various springs, spring brackets, bases, end covers, flexible straps, flexible sleeves, various functional components/parts (such as module mounting parts used for mounting spring modules onto mounting racks, various snap-fit parts/components, fixing parts/components, locking structures/components and constraint members, for limiting or fixing relative position relationship between adjacent spring modules) described in the above embodiments. At the same time, different spring cushions may be formed by any combination of spring bags, spring modules, mounting brackets, sponge covers, sponge blocks, fixing nets, spring cushion outer covers, spring cushion base cloths, etc. described in the above embodiments as required.

[**0348**] The scope of protection of the present disclosure is limited only by the claims. Thanks to the teaching of the present disclosure, those skilled in the art will appreciate that alternative structures of the structures disclosed in the present disclosure may be rewarded as feasible alternative embodiments, and the embodiments disclosed in the present disclosure may be combined to produce new embodiments, which also fall within the scope of the accompanying claims.

1-31. (canceled)

32. A spring module for making a furniture spring cushion, comprising:

a conical spring; and

a spring bracket configured to accommodate the conical spring therein, the spring bracket comprising:

a square base, the base having a spring fixing part for seating an end of the conical spring;

an end cover arranged opposite to the base; and

a plurality of flexible straps, each flexible strap having ends fixedly connected to the base and the end cover respectively,

wherein when the one end of the conical spring is arranged on the spring fixing part, the other end of the conical spring abuts against the end cover, and

wherein the spring module further comprises locking structures arranged on four sides of the base, the locking structures configured to engage with locking structures of an adjacent spring module.

33. The spring module according to claim **32**, wherein the flexible straps are positioned outside the conical spring.

34. The spring module according to claim **33**, wherein the locking structures comprise:

convex parts extending out from the base perpendicular to sides of the base; and

concave parts extending in from the base perpendicular to the sides of the base;

wherein the convex parts and the concave parts are configured such that the convex parts of the spring module are engageable with concave parts of an adjacent spring module.

35. The spring module according to claim **34**, wherein the convex parts and the concave parts are substantially triangular.

36. The spring module according to claim **35**, wherein an upper surface and/or a lower surface of the convex parts include a boss and an upper wall and/or a lower wall has a through hole the boss configured to be removably received in the through hole of the concave part of an adjoining spring module.

37. The spring module according to claim **34**, wherein the convex parts and the concave parts are arranged alternately with each other on the sides of the base.

38. The spring module of claim **32**, wherein the conical spring is installed in the spring bracket with a predetermined initial compression force

39. The spring module of claim **32**, wherein four flexible straps spaced apart from each other are evenly spaced apart around a periphery of the end cover.

40. The spring module according to claim **32**, wherein an opening is formed at a center of the end cover.

41. The spring module according to claim **32**, wherein the base and the end cover form a shape of substantially a frustocone, wherein the end cover forms a small end of the frustocone, the base forms a large end of the frustocone, and an opening is formed at a central position of the base, such that the end cover and at least some of the flexible straps of an adjacent spring module are able to enter into an interior of the spring module via the opening.

42. The spring module according to claim **32**, wherein a portion of the conical spring is a double-wire spring part.

43. The spring module according to claim **42**, wherein the double-wire spring part extends from a large-diameter end of the conical spring to about $\frac{2}{3}$ height of the conical spring.

* * * * *