



US 20190183862A1

(19) **United States**

(12) **Patent Application Publication**
Azamian et al.

(10) **Pub. No.: US 2019/0183862 A1**

(43) **Pub. Date: Jun. 20, 2019**

(54) **ISOXAZOLINE PARASITICIDE FORMULATIONS AND METHODS FOR TREATING BLEPHARITIS**

Publication Classification

(71) Applicant: **Tarsus Pharmaceuticals, Inc.**, Newport Beach, CA (US)

(51) **Int. Cl.**
A61K 31/422 (2006.01)
A61K 47/26 (2006.01)
A61K 9/00 (2006.01)
A61P 33/14 (2006.01)
A61P 27/02 (2006.01)

(72) Inventors: **Bobak Robert Azamian**, Newport Coast, CA (US); **Douglas Michael Ackermann**, Reno, NV (US); **Shawn D. Hickok**, Aliso Viejo, CA (US); **Joseph G. Vehige**, Newport Coast, CA (US)

(52) **U.S. Cl.**
CPC *A61K 31/422* (2013.01); *A61K 47/26* (2013.01); *A61P 27/02* (2018.01); *A61P 33/14* (2018.01); *A61K 9/0048* (2013.01)

(21) Appl. No.: **16/221,390**

(57) **ABSTRACT**

(22) Filed: **Dec. 14, 2018**

Related U.S. Application Data

(60) Provisional application No. 62/599,213, filed on Dec. 15, 2017, provisional application No. 62/615,855, filed on Jan. 10, 2018, provisional application No. 62/626,612, filed on Feb. 5, 2018, provisional application No. 62/689,787, filed on Jun. 25, 2018, provisional application No. 62/746,498, filed on Oct. 16, 2018.

Disclosed herein are methods for treating or preventing ophthalmic and dermatologic conditions in a patient, including ocular surface conditions such as blepharitis. The methods can include topically administering directly to an ocular surface of one or more eyes of a patient in need of treatment thereof an effective amount of an isoxazoline parasiticide, formamidine parasiticide, or other active ingredient, formulated into an ophthalmic composition, the ophthalmic composition further comprising a pharmaceutically acceptable vehicle. Compositions are also disclosed.

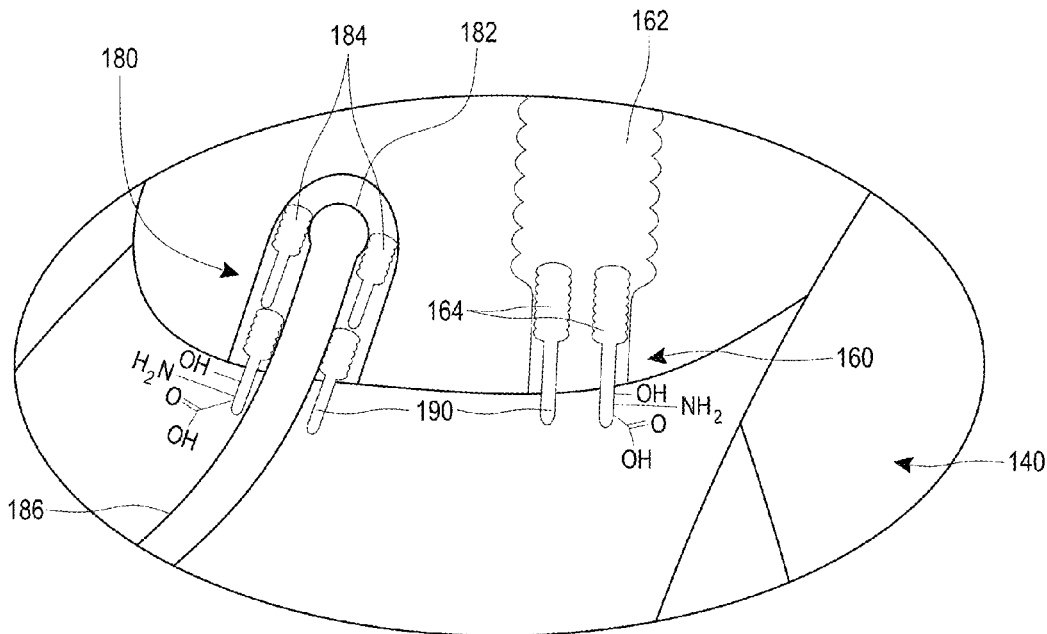

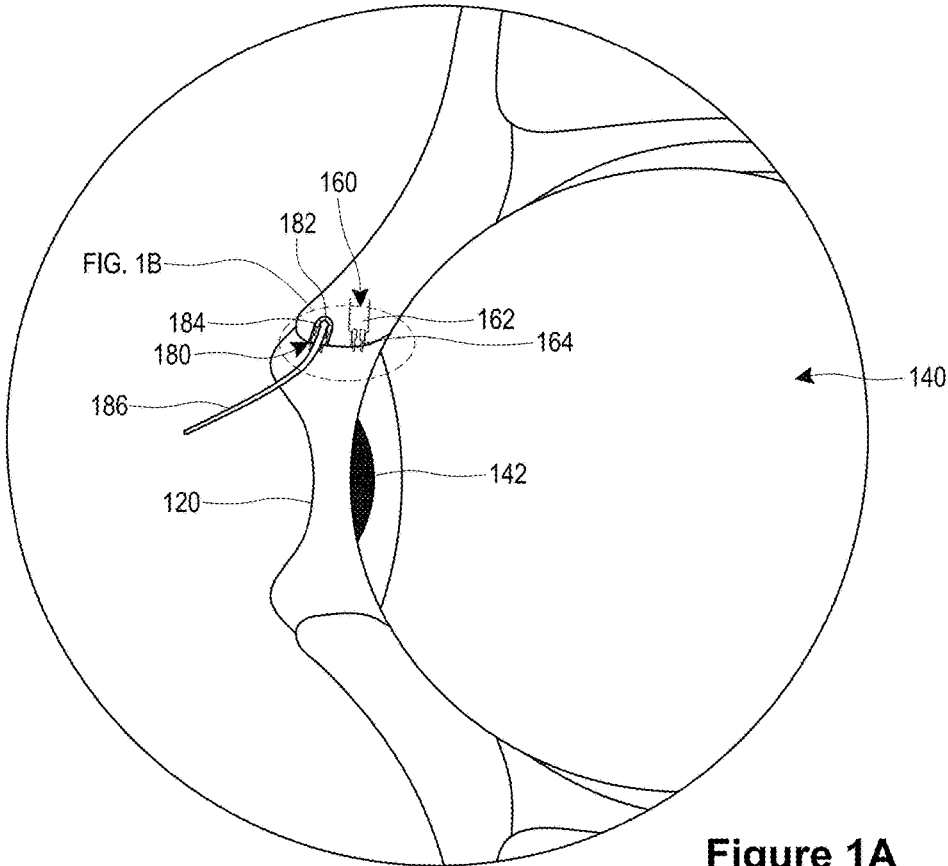

Figure 1A

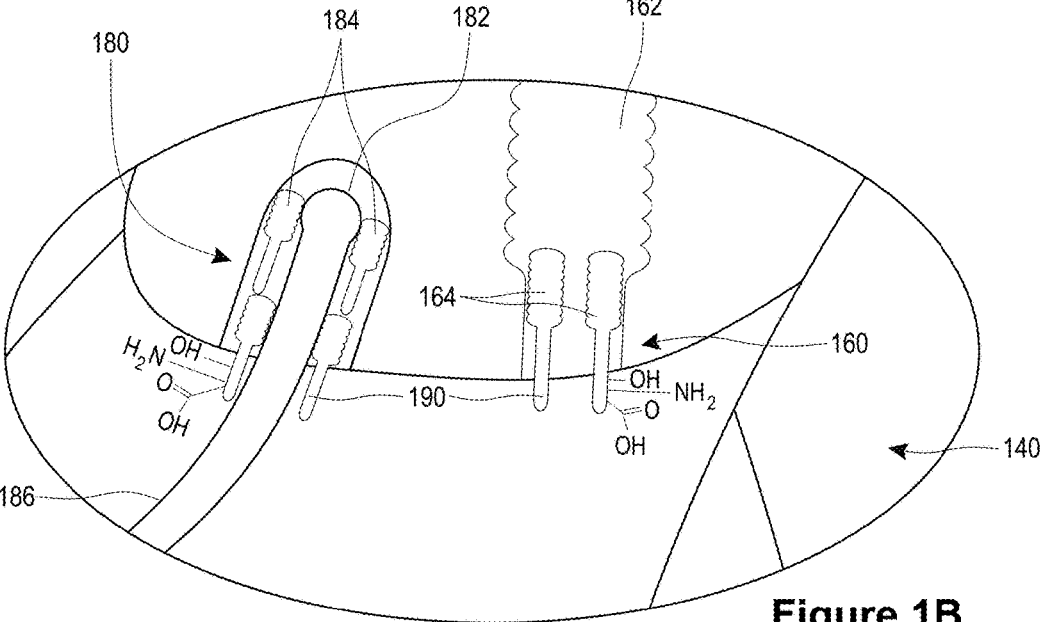

Figure 1B

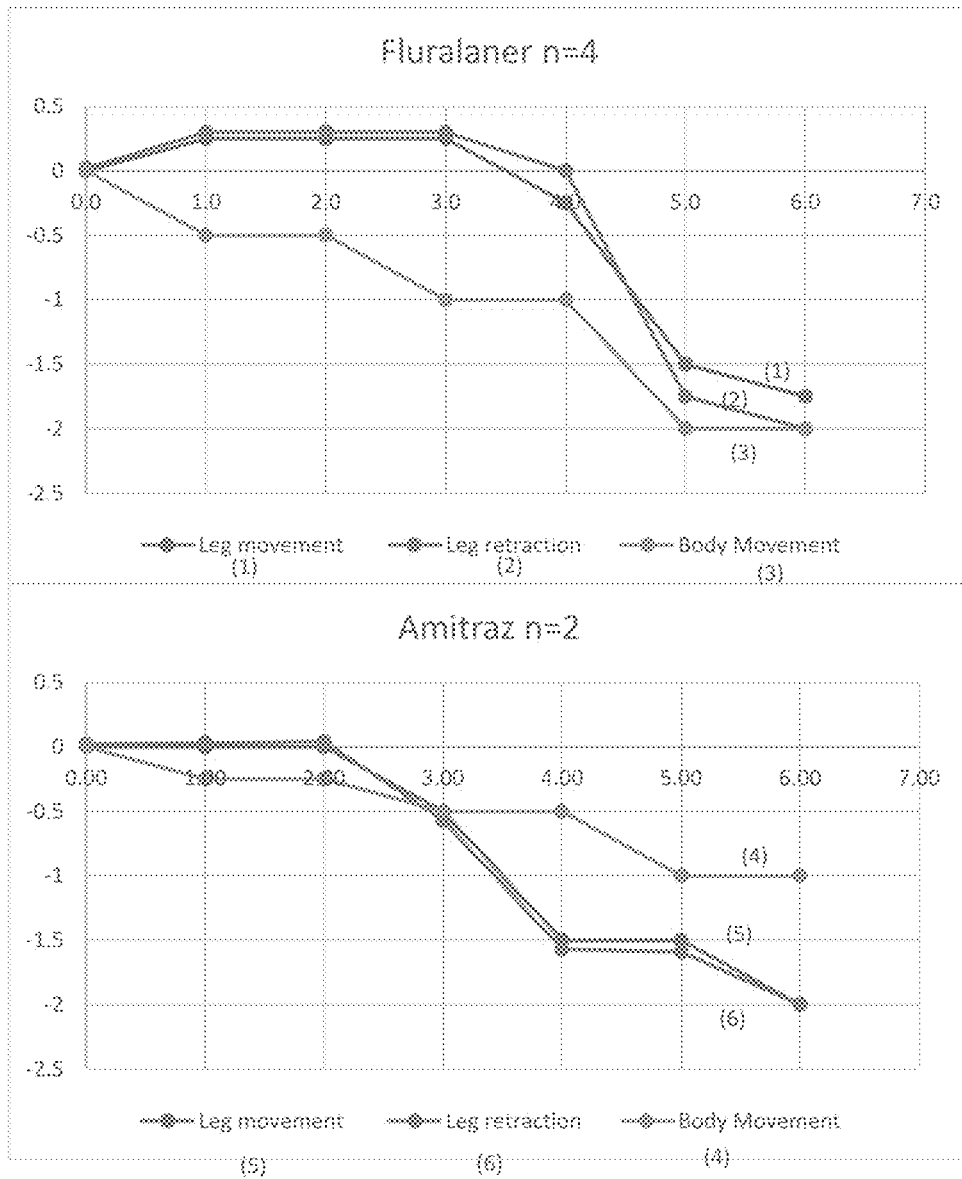
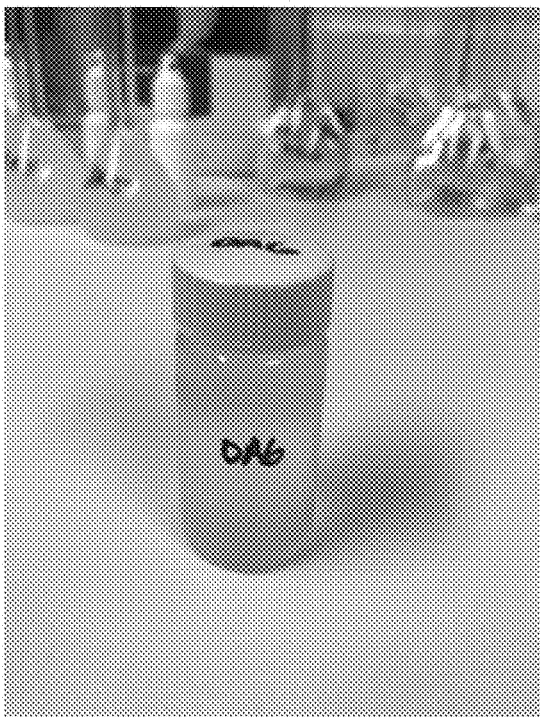

Figure 2



0.1% amitraz

Figure 3A



0.05% and 0.1% fluralaner

Figure 3B

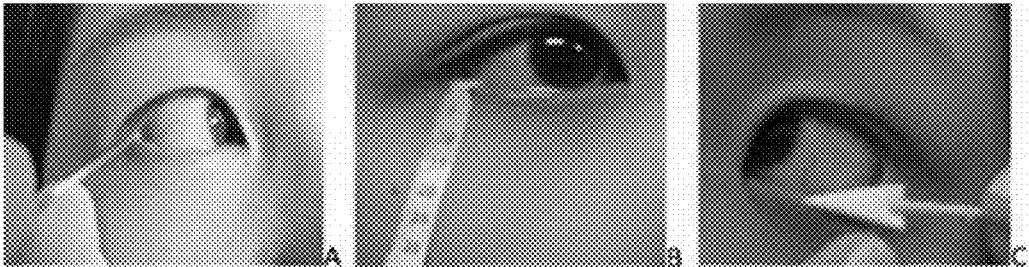

Figure 4A

Figure 4B

Figure 4C

**ISOXAZOLINE PARASITICIDE
FORMULATIONS AND METHODS FOR
TREATING BLEPHARITIS**

PRIORITY CLAIM

[0001] This application claims the benefit under 35 U.S.C. § 119(e) as a nonprovisional application of each of U.S. Prov. App. Nos. 62/599,213 filed on Dec. 15, 2017, 62/615,855 filed on Jan. 10, 2018, 62/626,612 filed on Feb. 5, 2018, 62/689,787 filed on Jun. 25, 2018, and 62/746,498 filed on Oct. 16, 2018, each of which are hereby incorporated by reference in their entireties.

BACKGROUND

[0002] Blepharitis, or inflammation of the eyelids, is a common, often chronic condition that can be challenging to treat, and affect any age group. Blepharitis can be both anterior (outer surface of the eyelid affected, where the eyelashes are attached) and/or posterior (inner surface of the eyelid affected). Blepharitis can be associated with systemic diseases including rosacea and seborrheic dermatitis, and be related to other ophthalmic diseases including chalazion, conjunctivitis, keratitis, and dry eyes.

[0003] *Demodex folliculorum* and *Demodex brevis* are microscopic, obligate, elongated mites that are the most common permanent intracutaneous parasites inhabiting the hair follicles and sebaceous glands of humans and animals. A total of 65 *Demodex* species have been described, parasitizing 11 orders of mammals and belonging to the family Demodicidae of the order Acarina, class Arachnida. Mating takes place in the follicle opening and eggs are laid inside the hair follicles or sebaceous glands. The six-legged larvae hatch after 3-4 days, and the larvae develop into adults in about 7 days. *Demodex* has a life cycle of about 14 days. The total lifespan of a *Demodex* mite is several weeks. The dead mites decompose inside the hair follicles or sebaceous glands.

[0004] *Demodex* can be found on the face, including cheeks, nose, chin, forehead, temples, eye lashes, brows, and also on the scalp, neck, and ears. Other seborrheic locations such as naso-labial folds, peri-orbital areas, and less commonly upper and medial region of chest and back can also be infested. *Demodex* may also be found on the penis, mons veneris, buttocks, and in the ectopic sebaceous glands in the buccal mucosa. In some cases, a mite density of greater than 5 mites/cm² in the pilo-sebaceous unit or 5 or more mites per follicle correlates with a *Demodex* infestation.

[0005] Among a wide range of reported species, only two, *Demodex folliculorum* and *Demodex brevis*, are found to parasitize the human body surface. *Demodex folliculorum* has been found for example on eyelash follicles, while *Demodex brevis* has been found, for example, proximate meibomian (tarsal) glands around the eye and sebaceous glands of the skin. Meibomian glands are a holocrine type of exocrine glands, at the rim of the eyelids inside the tarsal plate, responsible for the supply of meibum, an oily substance that prevents evaporation of the eye's tear film. Meibum prevents tear spillage onto the cheek, trapping tears between the oiled edge and the eyeball, and makes the closed lids airtight. There are approximately 50 glands on the upper eyelids and 25 glands on the lower eyelids. Symbiotic bacteria on the mites also can contribute to pathology. Increased sebum secretion and an increased num-

ber of sebaceous glands can provide a favorable habitat for the mites. While some level of *Demodex* can be asymptomatic, multiplication of *Demodex* mites to high densities, and/or a concurrent immune imbalance usually leads to skin damage. A growing body of literature implicates *Demodex* mites in anterior and posterior blepharitis. For example *Demodex* has been implicated in 45% of blepharitis cases. It has been estimated that the prevalence of ocular surface disease is about 30 million patients; 19 million of which have Meibomian gland dysfunction/posterior blepharitis; 9 million with *Demodex* infestation, and 4 million with clear signs of *Demodex*. Blepharitis is a significant diagnosis, with no approved therapy currently in the US. Safe, efficacious therapies to treat blepharitis and other ophthalmic and dermatologic conditions are needed.

SUMMARY

[0006] In some embodiments, disclosed herein are topical therapeutic agents, including but not limited to topical pharmaceutical agents including one or more isoxazoline parasiticides, formamidine parasiticides, phenylpyrazole parasiticides, drugs generally used for the treatment of Alzheimer's disease (e.g., galantamine and others), and other agents for the treatment of various ophthalmic and dermatologic conditions.

[0007] In some configurations, disclosed herein is a method for treating blepharitis in a patient, comprising topically administering directly to an ocular surface of one or more eyes of a patient in need of treatment thereof an effective amount of an isoxazoline parasiticide, formulated into an ophthalmic composition, the ophthalmic composition further comprising a pharmaceutically acceptable vehicle.

[0008] In some configurations, the ophthalmic composition is sterile and non-irritating to the eye.

[0009] In some configurations, the isoxazoline parasiticide can be the sole active ingredient of the ophthalmic composition.

[0010] In some configurations, from about 0.01% to about 1% of the isoxazoline parasiticide with respect to the total weight of the composition is administered.

[0011] In some configurations, about 0.03% by weight of the isoxazoline parasiticides with respect to the total weight of the composition is administered.

[0012] In some configurations, about 0.10% by weight of the isoxazoline parasiticides with respect to the total weight of the composition is administered.

[0013] In some configurations, the ophthalmic composition comprises an eye drop.

[0014] In some configurations, the ophthalmic composition does not include any essential oils.

[0015] In some configurations, the isoxazoline parasiticide is selected from the group consisting of: fluralaner, sarolaner, lotilaner, afoxolaner, and fluxametamide.

[0016] In some configurations, the ocular surface comprises at least one of the conjunctiva or cornea of the one or more eyes of the patient.

[0017] In some configurations, the ophthalmic composition comprises a polysorbate.

[0018] In some configurations, disclosed herein is a method for treating blepharitis in a patient, comprising topically administering directly to one or more of the eye, eyelids, or eyelashes of a patient in need of treatment thereof an effective amount of an isoxazoline parasiticide, formu-

lated into an ophthalmic composition further comprising a pharmaceutically acceptable vehicle, wherein the ophthalmic composition is sterile and non-irritating to the eye, wherein the isoxazoline parasiticide is the sole active ingredient of the ophthalmic composition.

[0019] In some configurations, the patient's eyes are closed upon topically administering the ophthalmic composition, such that the composition contacts orifices of Meibomian glands of the patient and outside of eyelid margins of the patient.

[0020] In some configurations, the method further comprises spreading the composition onto the eyelashes and follicles of the eyelashes.

[0021] In some configurations, the method further comprises spreading the composition onto the eyelashes and follicles of the eyelashes with an applicator.

[0022] In some configurations, from about 0.001% to about 1% of the isoxazoline parasiticide is administered.

[0023] In some configurations, from about 0.001% to about 1% of the isoxazoline parasiticide is administered.

[0024] In some configurations, the method further comprises topically administering the ophthalmic composition at least once daily for at least about 2 weeks.

[0025] In some configurations, the method further comprises topically administering the ophthalmic composition at least once daily for at least about 4 weeks.

[0026] In some configurations, disclosed herein is a method for treating an ocular *Demodex* infestation in a patient, comprising topically administering directly to one or more of the eyes, eyelids, or eyelashes of one or more eyes of a patient in need of treatment thereof, an effective amount of an isoxazoline parasiticide, formulated into an ophthalmic composition further comprising a pharmaceutically acceptable vehicle, wherein the ophthalmic composition is sterile and non-irritating to the eye, wherein the isoxazoline parasiticide is the sole active ingredient of the ophthalmic composition.

[0027] In some configurations, the method further comprises receiving a first assessment of a quantity of *Demodex* mites on an anatomical structure of the patient, and topically administering the ophthalmic composition if the quantity of *Demodex* mites is greater than a predetermined value.

[0028] In some configurations, the ophthalmic formulation causes an abdomen and tail of *Demodex* mites on the patient to stop moving more quickly relative to a cephalothorax of the *Demodex* mites.

[0029] In some configurations, disclosed herein is a method of treating blepharitis and/or rosacea, comprising topically applying isoxazoline parasiticides proximate one or more eyelashes, the topically applying therapeutically effective to preferentially be absorbed by a body of the *Demodex* mite with respect to ingestion by the *demodex* mite sufficient to cause reduced movement of the body of the *Demodex* mite with respect to a head of the *demodex* mite, the method sufficient to reduce or eliminate *Demodex* mites proximate the eyelashes, resulting in improvement of the manifestations of blepharitis and/or rosacea.

[0030] In some configurations, disclosed herein is a topical ophthalmic formulation for treating blepharitis in a patient, comprising an effective amount of an isoxazoline parasiticide and a pharmaceutically acceptable vehicle, wherein the ophthalmic composition is sterile and non-irritating to the eye, wherein the isoxazoline parasiticide is the sole active ingredient of the ophthalmic composition.

[0031] In some configurations, from about 0.01% to about 1% of the isoxazoline parasiticide with respect to the total weight of the composition is administered.

[0032] In some configurations, about 0.03% by weight of the isoxazoline parasiticides with respect to the total weight of the composition is administered.

[0033] In some configurations, about 0.10% by weight of the isoxazoline parasiticides with respect to the total weight of the composition is administered.

[0034] In some configurations, the ophthalmic composition comprises an eye drop.

[0035] In some configurations, the ophthalmic composition does not include any essential oils.

[0036] In some configurations, the isoxazoline parasiticide is selected from the group consisting of: fluralaner, sarolaner, lotilaner, afoxolaner, and fluxametamide.

[0037] In some configurations, disclosed herein is a topical formulation for use in treating an ocular surface disease, comprising: an isoxazoline parasiticide; at least one of Pemulen and HPMC; polysorbate 80; glycerin; a buffering agent; and lauralkonium chloride, wherein the formulation is therapeutically effective to reduce or eliminate *Demodex* mites proximate the eyelashes, resulting in improvement of the manifestations of blepharitis and/or rosacea.

[0038] In some configurations, the formulation is for use in treating blepharitis.

[0039] In some configurations, the formulation is for use in treating anterior blepharitis.

[0040] In some configurations, the formulation is for use in treating posterior blepharitis.

[0041] In some configurations, the formulation is for use in treating ocular rosacea.

[0042] In some configurations, disclosed herein is a method for treating blepharitis in a patient, comprising topically administering directly to an ocular surface of one or more eyes of a patient in need of treatment thereof an effective amount of a formamidine parasiticide, formulated into an ophthalmic composition, the ophthalmic composition further comprising a pharmaceutically acceptable vehicle, wherein the ophthalmic composition is sterile and non-irritating to the eye, wherein the formamidine parasiticide is the sole active ingredient of the ophthalmic composition.

[0043] In some configurations, from about 0.01% to about 1% of the formamidine parasiticide with respect to the total weight of the composition is administered.

[0044] In some configurations, about 0.03% by weight of the formamidine parasiticides with respect to the total weight of the composition is administered.

[0045] In some configurations, about 0.10% by weight of the formamidine parasiticides with respect to the total weight of the composition is administered.

[0046] In some configurations, the ophthalmic composition comprises an eye drop.

[0047] In some configurations, the ophthalmic composition comprises an ointment or cream.

[0048] In some configurations, the ophthalmic composition does not include any essential oils.

[0049] In some configurations, the formamidine parasiticide is selected from the group consisting of: amitraz, N-(2,4-Dimethylphenyl)-N-methylformamidinium (DPMF), and 2,4-dimethylalanine.

[0050] In some configurations, the ocular surface comprises at least one of the conjunctiva or cornea of the one or more eyes of the patient.

[0051] In some configurations, the ophthalmic composition comprises a polysorbate.

[0052] In some configurations, disclosed herein is a method for treating blepharitis in a patient, comprising topically administering directly to one or more of the eye, eyelids, or eyelashes of a patient in need of treatment thereof an effective amount of a formamide parasiticide, formulated into an ophthalmic composition further comprising a pharmaceutically acceptable vehicle, wherein the ophthalmic composition is sterile and non-irritating to the eye, wherein the formamide parasiticide is the sole active ingredient of the ophthalmic composition.

[0053] In some configurations, the patient's eyes are closed upon topically administering the ophthalmic composition, such that the composition contacts orifices of meibomian glands of the patient and outside of eyelid margins of the patient.

[0054] In some configurations, the method further comprises spreading the composition onto the eyelashes and follicles of the eyelashes.

[0055] In some configurations, the method further comprises spreading the composition onto the eyelashes and follicles of the eyelashes with an applicator.

[0056] In some configurations, from about 0.001% to about 1% of the formamide parasiticide is administered.

[0057] In some configurations, from about 0.001% to about 1% of the formamide parasiticide is administered.

[0058] In some configurations, the method further comprises topically administering the ophthalmic composition at least once daily for at least about 2 weeks.

[0059] In some configurations, the method further comprises topically administering the ophthalmic composition at least once daily for at least about 4 weeks.

[0060] In some configurations, disclosed herein is a method for treating an ocular *Demodex* infestation in a patient, comprising topically administering directly to one or more of the eyes, eyelids, or eyelashes of one or more eyes of a patient in need of treatment thereof, an effective amount of a formamide parasiticide, formulated into an ophthalmic composition further comprising a pharmaceutically acceptable vehicle, wherein the ophthalmic composition is sterile and non-irritating to the eye, wherein the formamide parasiticide is the sole active ingredient of the ophthalmic composition.

[0061] In some configurations, the method further comprises receiving a first assessment of a quantity of *Demodex* mites on an anatomical structure of the patient, and topically administering the ophthalmic composition if the quantity of *Demodex* mites is greater than a predetermined value.

[0062] In some configurations, the ophthalmic formulation causes an abdomen and tail of *Demodex* mites on the patient to stop moving more quickly relative to a cephalothorax of the *Demodex* mites.

[0063] In some configurations, disclosed herein is a method of treating blepharitis and/or rosacea, comprising topically applying formamide parasiticides proximate one or more eyelashes, the topically applying therapeutically effective to preferentially be absorbed by a body of the *Demodex* mite with respect to ingestion by the *demodex* mite sufficient to cause reduced movement of the body of the *Demodex* mite with respect to a head of the *demodex* mite,

the method sufficient to reduce or eliminate *Demodex* mites proximate the eyelashes, resulting in improvement of the manifestations of blepharitis and/or rosacea.

[0064] In some configurations, disclosed herein is a topical ophthalmic formulation for treating blepharitis in a patient, comprising an effective amount of a formamide parasiticide and a pharmaceutically acceptable vehicle, wherein the ophthalmic composition is sterile and non-irritating to the eye, wherein the formamide parasiticide is the sole active ingredient of the ophthalmic composition.

[0065] In some configurations, from about 0.01% to about 1% of the formamide parasiticide with respect to the total weight of the composition is administered.

[0066] In some configurations, about 0.03% by weight of the formamide parasiticides with respect to the total weight of the composition is administered.

[0067] In some configurations, about 0.10% by weight of the formamide parasiticides with respect to the total weight of the composition is administered.

[0068] In some configurations, the ophthalmic composition comprises an eye drop, a cream, or an ointment.

[0069] In some configurations, the ophthalmic composition does not include any essential oils.

[0070] In some configurations, the formamide parasiticide is selected from the group consisting of: amitraz, N-(2,4-Dimethylphenyl)-N-methylformamide (DPMF), and 2,4-dimethylaniline.

[0071] In some configurations, disclosed herein is a method for the treatment of symptoms of blepharitis and/or ocular rosacea in the eye(s), said symptoms being selected from the group consisting of a feeling of burning of the eye, a feeling of smarting of the eye, a feeling of dryness of the eye, an increased sensitivity to light, blurred vision, and a complication of ocular rosacea in the cornea, said method comprising topically administering directly to the conjunctiva and/or to the cornea(s) of the eye(s) of an individual in need of such treatment, a thus effective amount of formamide parasiticides, formulated into an eyewash composition with a pharmaceutically acceptable vehicle therefor, said eyewash composition being sterile, non-irritating and compatible with eye tissue.

[0072] In some configurations, from 0.001% to 10% by weight of formamide parasiticides with respect to the total weight of the composition is administered.

[0073] In some configurations, from 0.01% to 5% of formamide parasiticides with respect to the total weight of the composition is administered.

[0074] In some configurations, 0.03% by weight of formamide parasiticides with respect to the total weight of the composition is administered.

[0075] In some configurations, 0.10% by weight of formamide parasiticides with respect to the total weight of the composition is administered.

[0076] In some configurations, disclosed herein is a method of treating blepharitis and/or rosacea by orally-administering or topically applying formamide parasiticides in a dosage sufficient to fill and eliminate *Demodex* mites on one or more anatomical locations, resulting in cessation of the manifestations of blepharitis and/or rosacea.

[0077] In some configurations, said doses of formamide parasiticides are repeated about two to four times with spacing of three to seven days between them.

[0078] In some configurations, said topically-applied formamidine parasiticides is formulated in a carrier lotion, cream, or gel.

[0079] In some configurations, the concentration of formamidine parasiticides in said topically-applied lotion, cream, or gel is about one to five percent by weight.

[0080] In some configurations, said topically-applied formamidine parasiticides is applied to eyelids.

[0081] In some configurations, said topically-applied formamidine parasiticides is applied to affected skin areas at least once and not more than twice daily for a period of about two to four weeks.

[0082] In some configurations, said topically-applied formamidine parasiticides is encapsulated inside microliposomes before being formulated into said carrier lotion, cream, or gel.

[0083] In some configurations, disclosed herein is a composition for treating blepharitis and/or rosacea comprising an oral or topical pharmaceutical formulation formamidine parasiticides in a dosage sufficient to eliminate *Demodex* mites on one or more anatomical locations, resulting in cessation of the manifestations of blepharitis and/or rosacea.

[0084] In some configurations, disclosed herein is a method for the treatment of cylindrical eyelash dandruff associated with blepharitis and/or ocular rosacea in the eye(s), said method comprising topically administering directly to the conjunctiva and/or to the cornea(s) of the eye(s) of an individual in need of such treatment, a thus effective amount of formamidine parasiticides, formulated into an eyewash composition with a pharmaceutically acceptable vehicle therefor, said eyewash composition being sterile, non-irritating and compatible with eye tissue.

[0085] In some configurations, from 0.001% to 10% by weight of formamidine parasiticides with respect to the total weight of the composition is administered.

[0086] In some configurations, from 0.01% to 5% of formamidine parasiticides with respect to the total weight of the composition is administered.

[0087] In some configurations, 0.03% by weight of formamidine parasiticides with respect to the total weight of the composition is administered.

[0088] In some configurations, 0.10% by weight of formamidine parasiticides with respect to the total weight of the composition is administered.

[0089] In some configurations, disclosed herein is a method of treating blepharitis and/or rosacea by orally administering or topically applying formamidine parasiticides in a dosage sufficient to fill and eliminate *Demodex* mites on one or more anatomical locations, resulting in cessation of the manifestations of blepharitis and/or rosacea.

[0090] In some configurations, said doses of formamidine parasiticides are repeated about two to four times with spacing of three to seven days between them.

[0091] In some configurations, said topically-applied formamidine parasiticides is formulated in a carrier lotion, cream, or gel.

[0092] In some configurations, the concentration of formamidine parasiticides in said topically-applied lotion, cream, or gel is about one to five percent by weight,

[0093] In some configurations, said topically-applied formamidine parasiticides is applied to eyelids.

[0094] In some configurations, said topically-applied formamidine parasiticides is applied to affected skin areas at least once and not more than twice daily for a period of about two to four weeks.

[0095] In some configurations, said topically-applied formamidine parasiticides is encapsulated inside microliposomes before being formulated into said carrier lotion, cream, or gel.

[0096] In some configurations, disclosed herein is a composition for treating blepharitis and/or rosacea comprising an oral or topical pharmaceutical formulation formamidine parasiticides in a dosage sufficient to eliminate *Demodex* mites on one or more anatomical locations, resulting in cessation of the manifestations of blepharitis and/or rosacea.

[0097] In some configurations, disclosed herein is a method for the treatment of symptoms of blepharitis and/or ocular rosacea in the eye(s), said symptoms being selected from the group consisting of a feeling of burning of the eye, a feeling of smarting of the eye, a feeling of dryness of the eye, an increased sensitivity to light, blurred vision, and a complication of ocular rosacea in the cornea, said method comprising topically administering directly to the conjunctiva and/or to the cornea(s) of the eye(s) of an individual in need of such treatment, a thus effective amount of formamidine parasiticides, formulated into an eyewash composition with a pharmaceutically acceptable vehicle therefor, said eyewash composition being sterile, non-irritating and compatible with eye tissue.

[0098] In some configurations, from 0.001% to 10% by weight of formamidine parasiticides with respect to the total weight of the composition is administered.

[0099] In some configurations, from 0.01% to 5% of formamidine parasiticides with respect to the total weight of the composition is administered.

[0100] In some configurations, 0.03% by weight of formamidine parasiticides with respect to the total weight of the composition is administered.

[0101] In some configurations, 0.10% by weight of formamidine parasiticides with respect to the total weight of the composition is administered.

[0102] In some configurations, disclosed herein is a method of treating blepharitis and/or rosacea by orally administering or topically applying formamidine parasiticides in a dosage sufficient to fill and eliminate *Demodex* mites on one or more anatomical locations, resulting in cessation of the manifestations of blepharitis and/or rosacea.

[0103] In some configurations, said doses of formamidine parasiticides are repeated about two to four times with spacing of three to seven days between them.

[0104] In some configurations, said topically-applied formamidine parasiticides is formulated in a carrier lotion, cream, or gel.

[0105] In some configurations, the concentration of formamidine parasiticides in said topically-applied lotion, cream, or gel is about one to five percent by weight.

[0106] In some configurations, said topically-applied formamidine parasiticides is applied to eyelids.

[0107] In some configurations, said topically-applied formamidine parasiticides is applied to affected skin areas at least once and not more than twice daily for a period of about two to four weeks.

[0108] In some configurations, said topically-applied formamide parasiticides is encapsulated inside microliposomes before being formulated into said carrier lotion, cream, or gel.

[0109] In some configurations, disclosed herein is a composition for treating blepharitis and/or rosacea comprising an oral or topical pharmaceutical formulation formamide parasiticides in a dosage sufficient to eliminate *Demodex* mites on one or more anatomical locations, resulting in cessation of the manifestations of blepharitis and/or rosacea.

[0110] In some configurations, disclosed herein is a method for the treatment of cylindrical eyelash dandruff associated with blepharitis and/or ocular rosacea in the eye(s), said method comprising topically administering directly to the conjunctiva and/or to the cornea(s) of the eye(s) of an individual in need of such treatment, a thus effective amount of formamide parasiticides, formulated into an eyewash composition with a pharmaceutically acceptable vehicle therefor, said eyewash composition being sterile, non-irritating and compatible with eye tissue.

[0111] In some configurations, from 0.001% to 10% by weight of formamide parasiticides with respect to the total weight of the composition is administered.

[0112] In some configurations, from 0.01% to 5% of formamide parasiticides with respect to the total weight of the composition is administered.

[0113] In some configurations, 0.03% by weight of formamide parasiticides with respect to the total weight of the composition is administered.

[0114] In some configurations, 0.10% by weight of formamide parasiticides with respect to the total weight of the composition is administered.

[0115] In some configurations, disclosed herein is a method of treating blepharitis and/or rosacea by orally-administering or topically applying formamide parasiticides in a dosage sufficient to fill and eliminate *Demodex* mites on one or more anatomical locations, resulting in cessation of the manifestations of blepharitis and/or rosacea.

[0116] In some configurations, said doses of formamide parasiticides are repeated about two to four times with spacing of three to seven days between them.

[0117] In some configurations, said topically-applied formamide parasiticides is formulated in a carrier lotion, cream, or gel.

[0118] In some configurations, the concentration of formamide parasiticides in said topically-applied lotion, cream, or gel is about one to five percent by weight.

[0119] In some configurations, said topically-applied formamide parasiticides is applied to eyelids.

[0120] In some configurations, said topically-applied formamide parasiticides is applied to affected skin areas at least once and not more than twice daily for a period of about two to four weeks.

[0121] In some configurations, said topically-applied formamide parasiticides is encapsulated inside microliposomes before being formulated into said carrier lotion, cream, or gel.

[0122] In some configurations, disclosed herein is a composition for treating blepharitis and/or rosacea comprising an oral or topical pharmaceutical formulation formamide parasiticides in a dosage sufficient to eliminate *Demodex* mites on one or more anatomical locations, resulting in cessation of the manifestations of blepharitis and/or rosacea.

[0123] In some configurations, disclosed herein is a method for the treatment of symptoms of blepharitis and/or ocular rosacea in the eye(s), said symptoms being selected from the group consisting of a feeling of burning of the eye, a feeling of smarting of the eye, a feeling of dryness of the eye, an increased sensitivity to light, blurred vision, and a complication of ocular rosacea in the cornea, said method comprising topically administering directly to the conjunctiva and/or to the cornea(s) of the eye(s) of an individual in need of such treatment, a thus effective amount of phenylpyrazole parasiticides, formulated into an eyewash composition with a pharmaceutically acceptable vehicle therefor, said eyewash composition being sterile, non-irritating and compatible with eye tissue.

[0124] In some configurations, from 0.001% to 10% by weight of phenylpyrazole parasiticides with respect to the total weight of the composition is administered.

[0125] In some configurations, from 0.01% to 5% of phenylpyrazole parasiticides with respect to the total weight of the composition is administered.

[0126] In some configurations, 0.03% by weight of phenylpyrazole parasiticides with respect to the total weight of the composition is administered.

[0127] In some configurations, 0.10% by weight of phenylpyrazole parasiticides with respect to the total weight of the composition is administered.

[0128] In some configurations, disclosed herein is a method of treating blepharitis and/or rosacea by orally-administering or topically-applying phenylpyrazole parasiticides in a dosage sufficient to fill and eliminate *Demodex* mites on one or more anatomical locations, resulting in cessation of the manifestations of blepharitis and/or rosacea.

[0129] In some configurations, said doses of phenylpyrazole parasiticides are repeated about two to four times with spacing of three to seven days between them.

[0130] In some configurations, said topically-applied phenylpyrazole parasiticides is formulated in a carrier lotion, cream, or gel.

[0131] In some configurations, the concentration of phenylpyrazole parasiticides in said topically-applied lotion, cream, or gel is about one to five percent by weight.

[0132] In some configurations, said topically-applied phenylpyrazole parasiticides is applied to eyelids.

[0133] In some configurations, said topically-applied phenylpyrazole parasiticides is applied to affected skin areas at least once and not more than twice daily for a period of about two to four weeks.

[0134] In some configurations, said topically-applied phenylpyrazole parasiticides is encapsulated inside microliposomes before being formulated into said carrier lotion, cream, or gel.

[0135] In some configurations, disclosed herein is a composition for treating blepharitis and/or rosacea comprising an oral or topical pharmaceutical formulation phenylpyrazole parasiticides in a dosage sufficient to eliminate *Demodex* mites on one or more anatomical locations, resulting in cessation of the manifestations of blepharitis and/or rosacea.

[0136] In some configurations, disclosed herein is a method for the treatment of cylindrical eyelash dandruff associated with blepharitis and/or ocular rosacea in the eye(s), said method comprising topically administering directly to the conjunctiva and/or to the cornea(s) of the eye(s) of an individual in need of such treatment, a thus effective amount of phenylpyrazole parasiticides, formu-

lated into an eyewash composition with a pharmaceutically acceptable vehicle therefor, said eyewash composition being sterile, non-irritating and compatible with eye tissue.

[0137] In some configurations, from 0.001% to 10% by weight of phenylpyrazole parasiticides with respect to the total weight of the composition is administered.

[0138] In some configurations, from 0.01% to 5% of phenylpyrazole parasiticides with respect to the total weight of the composition is administered.

[0139] In some configurations, 0.03% by weight of phenylpyrazole parasiticides with respect to the total weight of the composition is administered.

[0140] In some configurations, 0.10% by weight of phenylpyrazole parasiticides with respect to the total weight of the composition is administered.

[0141] In some configurations, disclosed herein is a method of treating blepharitis and/or rosacea by orally administering or topically applying phenylpyrazole parasiticides in a dosage sufficient to fill and eliminate *Demodex* mites on one or more anatomical locations, resulting in cessation of the manifestations of blepharitis and/or rosacea.

[0142] In some configurations, said doses of phenylpyrazole parasiticides are repeated about two to four times with spacing of three to seven days between them.

[0143] In some configurations, said topically-applied phenylpyrazole parasiticides is formulated in a carrier lotion, cream, or gel.

[0144] In some configurations, the concentration of phenylpyrazole parasiticides in said topically-applied lotion, cream, or gel is about one to five percent by weight.

[0145] In some configurations, said topically-applied phenylpyrazole parasiticides is applied to eyelids.

[0146] In some configurations, said topically-applied phenylpyrazole parasiticides is applied to affected skin areas at least once and not more than twice daily for a period of about two to four weeks.

[0147] In some configurations, said topically-applied phenylpyrazole parasiticides is encapsulated inside microliposomes before being formulated into said carrier lotion, cream, or gel.

[0148] In some configurations, disclosed herein is a composition for treating blepharitis and/or rosacea comprising an oral or topical pharmaceutical formulation phenylpyrazole parasiticides in a dosage sufficient to eliminate *Demodex* mites on one or more anatomical locations, resulting in cessation of the manifestations of blepharitis and/or rosacea.

[0149] In some configurations, disclosed herein is a method for the treatment of symptoms of blepharitis and/or ocular rosacea in the eye(s), said symptoms being selected from the group consisting of a feeling of burning of the eye, a feeling of smarting of the eye, a feeling of dryness of the eye, an increased sensitivity to light, blurred vision, and a complication of ocular rosacea in the cornea, said method comprising topically administering directly to the conjunctiva and/or to the cornea(s) of the eye(s) of an individual in need of such treatment, a thus effective amount of a drug used to treat Alzheimer's disease, formulated into an eyewash composition with a pharmaceutically acceptable vehicle therefor, said eyewash composition being sterile, non-irritating and compatible with eye tissue.

[0150] In some configurations, from 0.001% to 10% by weight of drug used to treat Alzheimer's disease with respect to the total weight of the composition is administered.

[0151] In some configurations, from 0.01% to 5% of drug used to treat Alzheimer's disease with respect to the total weight of the composition is administered.

[0152] In some configurations, 0.03% by weight of drug used to treat Alzheimer's disease with respect to the total weight of the composition is administered.

[0153] In some configurations, 0.10% by weight of drug used to treat Alzheimer's disease with respect to the total weight of the composition is administered.

[0154] In some configurations, disclosed herein is a method of treating blepharitis and/or rosacea by orally administering or topically applying drug used to treat Alzheimer's disease in a dosage sufficient to fill and eliminate *Demodex* mites on one or more anatomical locations, resulting in cessation of the manifestations of blepharitis and/or rosacea.

[0155] In some configurations, said doses of drug used to treat Alzheimer's disease are repeated about two to four times with spacing of three to seven days between them.

[0156] In some configurations, said topically-applied drug used to treat Alzheimer's disease is formulated in a carrier lotion, cream, or gel.

[0157] In some configurations, the concentration of drug used to treat Alzheimer's disease in said topically-applied lotion, cream, or gel is about one to five percent by weight.

[0158] In some configurations, said topically-applied drug used to treat Alzheimer's disease is applied to eyelids.

[0159] In some configurations, said topically-applied drug used to treat Alzheimer's disease is applied to affected skin areas at least once and not more than twice daily for a period of about two to four weeks.

[0160] In some configurations, said topically-applied drug used to treat Alzheimer's disease is encapsulated inside microliposomes before being formulated into said carrier lotion, cream, or gel.

[0161] In some configurations, disclosed herein is a composition for treating blepharitis and/or rosacea comprising an oral or topical pharmaceutical formulation drug used to treat Alzheimer's disease in a dosage sufficient to eliminate *Demodex* mites on one or more anatomical locations, resulting in cessation of the manifestations of blepharitis and/or rosacea.

BRIEF DESCRIPTION OF THE FIGURES

[0162] FIGS. 1A-B schematically illustrate application of an ophthalmic formulation onto an eye with a *Demodex* infestation.

[0163] FIG. 2 illustrates data illustrating activity of selected anatomy of *Demodex* mites following therapy with a topical formulation.

[0164] FIGS. 3A-3B show examples of formulations with amitraz and fluralaner.

[0165] FIGS. 4A-4C illustrate embodiments of various diagnostic techniques for *Demodex* that do not necessarily require epilation.

DETAILED DESCRIPTION

[0166] In some embodiments, disclosed herein are topical therapeutic agents, including but not limited to topical pharmaceutical agents including one or more isoxazoline parasiticides, formanindine parasiticides, agents used for treating Alzheimer's disease, and other agents as disclosed herein for the treatment of various ophthalmic and derma-

ologic conditions. Also disclosed herein are methods of treating blepharitis, ocular rosacea, and *Demodex* infestation in patients in need thereof. In some embodiments, patients in need thereof can be treated with an active agent from the isoxazoline parasiticide family of chemicals), which include but are not limited to isoxazoline-substituted benzamide derivatives. Not to be limited by theory, isoxazoline parasiticides can act as GABA-chloride antagonists to selectively target the nervous system of certain organisms, including but not limited to *Demodex*. The GABA-mediated chloride influx can lead to hyperpolarization of the cellular membrane and generates an inhibitory postsynaptic potential, which decreases the probability of an action potential, and lead to paralysis and eventual death of *Demodex* mites. The isoxazoline parasiticide can include, for example, any number of fluralaner, sarolaner, lotilaner, afoxolaner, and/or flumetamide, including derivatives, analogues, and L- and D-isomers thereof, including but not limited to enantiomers, compositions comprising racemic mixtures, and enantiomerically pure compositions. In some embodiments, the isoxazoline parasiticide, formamidine parasiticide, or other active ingredients as disclosed herein are the only active ingredient utilized in the formulation and/or method. In some embodiments, the isoxazoline parasiticide is an isoxazoline-substituted benzamide derivative. In some embodiments, the isoxazoline parasiticide has one, two, three, or more fluorine groups, such as trifluorine groups in its chemical structure (e.g., R—CF₃).

[0167] Isoxazoline parasiticides have been conventionally utilized for veterinary applications, including chews and non-ophthalmic topical “pour on” solutions, although to the inventors’ knowledge no human formulations have been developed. Non-limiting examples of isoxazoline parasiticides can be found, for example, in U.S. Pat. No. 7,662,972 to Mita et al., U.S. Pat. No. 8,466,115 to Curtis et al., U.S. Pat. No. 7,964,204 to Lahm et al., and U.S. Pat. No. 8,383,659 to Nanchen et al., each of which are hereby incorporated by reference in their entireties. Additionally, U.S. Pub. No. 2010/0254960 A1, PCT Pub. No. WO 2007/070606 A2, PCT Pub. No. WO 2007/123855 A2, PCT Pub. No. WO 2010/003923 A1, U.S. Pat. Nos. 7,951,828, 7,662,972, U.S. Pub. No. 2010/0137372 A1, U.S. Pub. No. 2010/0179194 A2, U.S. Pub. No. 2011/0086886 A2, U.S. Pub. No. 2011/0059988 A1, US 2010/0179195 A1, PCT Pub. No. WO 2007/075459 A2 and U.S. Pat. No. 7,951,828, all of which are incorporated by reference in their entireties, describe various other parasiticial isoxazoline compounds. Veterinary oral formulations such as chews result in first pass liver metabolism as well as systemic effects, which can be undesirable in some cases for targeted local applications. A significant challenge is that the fluorinated and/or chlorinated groups of certain isoxazoline parasiticides cause these molecules to be highly insoluble in any pharmaceutical-based solutions including oil and water-based solutions, and having a solubility of less than about 1 mg/kg, or 1 mg/mL aqueous concentrations, or even less. Veterinary topical solutions of isoxazoline parasiticides have included, for example, dimethylacetamide, glycofurol, diethyltoluamide, and/or acetone. However, such solutions are only indicated as a “pour on” solution on the back of the neck of an animal, such as a cat or a dog, are unsuitable for ophthalmic use (and potentially toxic), and include instructions not to administer the solution in or around the eye. Such “pour on” solutions are absorbed systemically by the animal and do not result in

targeted local activity only. To the inventors’ knowledge, no isoxazoline parasiticides or formamidine parasiticide topical ophthalmic formulations have previously been developed. Therapeutic formulations that are safe and non-toxic for ocular use, and sufficiently soluble to be therapeutically efficacious to treat ocular *Demodex* and related conditions such as blepharitis, for example, are needed.

[0168] It has now been determined that compounds of the family of the isoxazoline parasiticides, formamidine parasiticides, agents to treat Alzheimer’s disease, and/or other agents as disclosed elsewhere herein can be suitable for the treatment of ophthalmic pathologies of any origin, particularly ophthalmic pathologies due to *Demodex folliculorum*, and more particularly blepharitis and/or ocular rosacea. Other conditions that can be treated via formulations and methods as disclosed herein include, for example, rosacea, pityriasis folliculorum, rosacea-like demodicosis, and demodicosis gravis, nonspecific facial dermatitis, steroid rosacea, androgenetic alopecia, madarosis, lupus miliaris disseminatus faciei, dissecting folliculitis, perioral dermatitis, acarica blepharo-conjunctivitis, papulopustular scalp eruptions, eosinophilic folliculitis, pustular folliculitis, grover’s diseases, and *Demodex* abscess.

[0169] Ivermectin is another drug that has been used to treat *Demodex*, and is generally more soluble than the isoxazoline parasiticides in solution. However, no known formulations are approved for ocular use (e.g., for blepharitis), and more efficacious therapeutic agents are needed. In some embodiments, a formulation and/or method does not involve an avermectin such as ivermectin or another macrocyclic lactone derivative. However, formulations can include an avermectin in other embodiments.

[0170] Disclosed herein are various embodiments of systems, methods, and formulations for the treatment of various eye conditions including but not limited to blepharitis, and the treatment of *Demodex* infestations (e.g., on the eyelid of a subject, such as a human). Embodiments can include any number of features as disclosed herein. Some embodiments do not include dimethylacetamide, glycofurol, diethyltoluamide, and/or acetone, at least some of which can be toxic or irritating to the eye in some cases.

[0171] Also disclosed herein is the use of topical isoxazoline parasiticides, formamidine parasiticides, agents to treat Alzheimer’s disease, and/or other agents as disclosed elsewhere herein for the treatment of blepharitis and methods of treating *Demodex* infestation and blepharitis in patients in need thereof.

[0172] Further disclosed are topical isoxazoline parasiticides, formamidine parasiticides, agents to treat Alzheimer’s disease, and/or other agents as disclosed elsewhere herein for the treatment of rosacea and/or ocular rosacea and methods of treating *Demodex* infestation and rosacea and/or ocular rosacea in patients in need thereof (e.g., from the isoxazoline parasiticides family of chemicals). Formulations and methods of reducing *Demodex* mite count proximate the eye of the patient and cylindrical eyelash dandruff are also disclosed.

[0173] Also disclosed herein is topical isoxazoline parasiticides, formamidine parasiticides, agents to treat Alzheimer’s disease, and/or other agents as disclosed elsewhere herein for the treatment of rosacea and/or ocular rosacea and methods of treating *Demodex* infestation and rosacea and/or ocular rosacea in patients in need thereof.

[0174] According to some embodiments, the pharmaceutical composition can include at least one, two, or more compounds selected from the family of the isoxazoline parasiticides including, for example, fluralaner, sarolaner, lotilaner, afoxolaner, and/or fluxametamide, is administered in particular for the treatment of conjunctivitis, blepharitis, ocular rosacea, or other indications including other ocular surface diseases such as meibomian gland dysfunction or dry eye disease.

[0175] Some embodiments can include derivatives, analogues, and L- and D-isomers of isoxazoline parasiticides, formamidine parasiticides, or other active therapeutic agents as disclosed elsewhere herein, including but not limited to enantiomers, compositions comprising racemic mixtures, and enantiomerically pure compositions.

[0176] In some embodiments, a dose of isoxazoline parasiticides, formamidine parasiticides, agents to treat Alzheimer's disease, and/or other agents as disclosed elsewhere herein can surprisingly be used that is lower than what has been shown to be clinically effective in veterinary medicine, which acts via systemic absorption via topical rinses or washes (e.g. at concentrations in the 1-10 nM, or 100 pM-1 nM range), or ranges including any two of the foregoing values. These lower effective concentrations may be, without limitation, due to direct absorption of drug by the mite body rather than ingestion of drug by the mite, with the abdomen of the mites being thinner (~0.5 μm) and more likely to absorb drug than the mites' cephalothorax (~2 μm). In some embodiments, direct absorption of drug by the mite body can be the mechanism responsible for at least about 50%, 60%, 70%, 80%, 90%, or more of the total uptake of the drug by the mite.

[0177] In some embodiments, daily and local treatment is administered rather than a large long-acting systemic dose (as has been done in veterinary medicine once a month, every 8 weeks, every 12 weeks, every 16 weeks, or less frequently). However, long-acting systemic or local doses could be used in other embodiments.

[0178] In some embodiments, dosing could be, for example, about or at least about 1, 2, 3, 4, 5, 6, 7, 8, or more times daily, such as 1 to 2 times daily. In some embodiments, therapy could also be weekly, single dose or a limited-course of treatment. In some embodiments, a formulation can be preferentially used in the morning, at night, or only at night, to target exposure of mites during mating hours.

[0179] In some embodiments, formulations can be advantageous in part due to the slow elimination rate of molecules such as isoxazoline parasiticides, however, a small and local dose allows the repeated and frequent dosing, which may be advantageous to disrupt the *Demodex* life cycle through effects on more susceptible juvenile forms, without associated systemic risks and side-effects.

[0180] In some embodiments, an active molecule may preferentially be hydrophobic so it concentrates in regions with either sebum or meibum oils (e.g., eye lash follicles and/or meibomian glands). A formulation may be preferentially water-based to facilitate delivery to and absorption by the hydrophilic chitinous chitosan exterior of *Demodex* mites.

[0181] In some embodiments, a therapeutic agent can be delivered in the form of a drop, cream, ointment, eye wash, wipe, salve, or gel, or immediate or sustained release formulation. In some embodiments, a therapeutic agent can be delivered in the form of a punctal or canalicular plug or

emulsion. In some cases, a form of an oily, gel-like, viscous ointment may also impede *Demodex* mite movement across the skin surface during mating.

[0182] In some embodiments, an isoxazoline parasiticide, formamidine parasiticide, agents to treat Alzheimer's disease, and/or other agents as disclosed elsewhere herein formulation may have preferential selectivity for the receptors of insects/mites/acari over vertebrate/mammalian/human receptors.

[0183] In some embodiments, an active agent is delivered in an oral formulation (e.g. tablet, capsule, solution, etc.), and a very small dose may be delivered to avoid meaningful systemic exposure or non-local dermal exposure (in contrast to veterinary teachings). However, in some embodiments, an active agent is delivered in a non-oral formulation, such as a topical formulation, e.g., a topical ophthalmic formulation.

[0184] In some embodiments, a dose of between, for example, 1 microgram to 1 mg/ml or 0.0001%-1% active agent (e.g. isoxazoline parasiticides, formamidine parasiticides, agents to treat Alzheimer's disease, and/or other agents as disclosed elsewhere herein) by weight, or between about 0.01% and 10% by weight, between about 0.05% and about 0.5% by weight, or about 0.01%, 0.015%, 0.02%, 0.025%, 0.03%, 0.04%, 0.05%, 0.06%, 0.07%, 0.08%, 0.09%, 0.10%, 0.15%, 0.20%, 0.25%, 0.30%, 0.35%, 0.40%, 0.45%, 0.50%, 0.55%, 0.60%, 0.65%, 0.70%, 0.75%, 0.80%, 0.85%, 0.90%, 0.95%, 1.00%, or ranges including any two of the aforementioned values, or 1 ng-1 microgram/ml or 0.0000001-0.0001% active agent (e.g. isoxazoline parasiticides, formamidine parasiticides, agents to treat Alzheimer's disease, and/or other agents as disclosed elsewhere herein) by weight, or 1 mg/ml-100 mg/ml or 0.1-10% active agent (e.g. isoxazoline parasiticides, formamidine parasiticides, agents to treat Alzheimer's disease, and/or other agents as disclosed elsewhere herein) by weight, or ranges including any of the foregoing values. In some embodiments, the isoxazoline parasiticides, formamidine parasiticides, agents to treat Alzheimer's disease, or other agents as disclosed elsewhere herein are the only active agent.

[0185] In some embodiments, an ophthalmic formulation can be configured for delivery directly onto an ocular surface, including but not limited to the conjunctiva and/or cornea of the eye. In some embodiments, an ophthalmic formulation can be configured for delivery directly or indirectly onto any number of the anterior or posterior eyelids, eye lashes, or eye brows. In some embodiments, an ophthalmic formulation is not directly delivered to any number of the conjunctiva, cornea, anterior or posterior eyelids, eye lashes, or eye brows.

[0186] An eyedrop formulation may be designed to specifically and simultaneously treat blepharitis and *Demodex* in both the eyelash follicles and/or the meibomian glands, without limitation due to oily additives, emulsions, ointment or cream based formulations, delivery instrument such as lash brushes, or site of application. In some embodiments, a "Drop and Coat the Lashes" (DACTL) technique can be used. A patient can be instructed to close the eye(s) upon administration, thus causing the formulation to come into contact with the orifices of the meibomian glands on the margin(s) of the eyelid, and for the formulation to accumulate outside of the lid margin. The patient can then utilize their finger or an applicator to spread formulation which has accumulated outside of the lid margin onto the eye lashes

and/or follicles of the eye lashes on the lower and/or upper eye lashes. Not to be limited by theory, as *Demodex* mites reside in both the eye lash hair follicles and in the meibomian glands, it can be advantageous for the eye drop formulation to be directly applied to one or both of these locations. Since these two targets in combination are unique to this disease, a therapeutic agent can be delivered to these locations simultaneously. The meibomian gland orifices are on the superior and inferior surfaces of the lower and upper eyelids, respectively. An eye drop placed directly onto the ocular surface thus allows for delivery of formulation directly to the upper and lower meibomian gland orifices.

[0187] Methods of treating blepharitis and/or *Demodex* infestation can include a formulation/treatment (or similar) delivered specifically by applying a drop in the eye, and then using a finger or instrument (e.g. lash brush) to coat the base of hair follicles in the upper and/or lower eyelids. In some embodiments, desirable features of a formulation can include any number of maximizing drug aqueous solubility to enhance bioavailability (in solution and suspensions), improve the residence time of the drug product in the eye using polymers/viscosity agents, and achieve acceptable visual acuity and comfort.

[0188] The viscosity of the formulation may be sufficiently high in some embodiments to cause coverage of formulation over meibomian gland orifices on upper and/or lower lid margins upon blinking or close of the eye.

[0189] In some cases, viscosity may be sufficiently high to slow evacuation of formulation through the puncta of the eye for at least 5 seconds, or 10 seconds or 20 seconds or 30 seconds or longer, to enhance contact time of formulation with meibomian gland orifices and to cause the formulation to spill over the lid margin to where it can be accessed for delivery to the eyelash follicles (e.g., by runoff, and/or by spreading of formulation using a finger and/or instrument).

[0190] Formulation constituents can be chosen to enable dissolution of active agent into a solution, but with a low concentration by weight of organic solvents, e.g. <50%, 20%, 10%, 5%, 2%, or 1%, or less or more by weight organic. This may be achieved at least in part by using a surfactant such as, for example, polysorbate-80 or polysorbate-20. In some cases, low concentrations of polysorbate 80 may be preferentially used, since higher concentrations may lead to isoxazoline parasiticides hydrolysis (e.g. 0.001-0.1% polysorbate 80 by weight).

[0191] In some cases, this can also be achieved and solubility of isoxazoline parasiticides enhanced through organic solvents such as propylene glycol.

[0192] Solubility and viscosity may be also simultaneously enhanced by selection of an appropriate additive, thereby minimizing osmolarity, e.g. with polyvinyl alcohol, carboxymethylcellulose or the like.

[0193] Formulation constituents can be chosen to enable dissolution of active agent (e.g. isoxazoline parasiticides or other active agents) into a solution, and one that is stable from hydrolytic reactions for up to 1, 1.5, 2 years, or more to enable commercial shelf life e.g., with an optimal pH range of neutral to slightly alkaline (e.g., pH 7-10, 7-7.5, or pH 5-7 in other embodiments).

[0194] The buffer concentration required to achieve the desired pH can be minimized in some cases, and thus retarding the hydrolysis rate (e.g., phosphate buffer concen-

tration 0.01-0.1M). This may also be achieved with organic solvents and surfactants at concentration ranges described above.

[0195] Cationic surfactants, through creation of cationic micelles, can also be advantageous by retarding the hydrolysis rate.

[0196] Emulsions and emulsifiers may be mixed with water to shield isoxazoline parasiticides, formamidine parasiticides, agents to treat Alzheimer's disease, and/or other agents and/or other active agents from water in an oil-in-water droplet, e.g., with a carbodiimide additive to prolong stability by forming more complex water-free micelles.

[0197] Water scavengers such as Stabaxol I^o (bis-2,6-diisopropylphenylcarbodiimide) may be added to achieve long-term oil-based formulations to clean solvents of water.

[0198] The pharmaceutical compositions in some embodiments can comprise at least one compound selected from among the family of the isoxazoline parasiticides, formamidine parasiticides, agents to treat Alzheimer's disease, and/or other agents and/or other active agents, are particularly useful for the treatment of ophthalmic symptoms, symptoms selected from a feeling or sensation of burning or of smarting of the eye, a feeling or sensation of a foreign body in the eye, a feeling or sensation of dryness of the eye, an increased sensitivity to light, blurred vision, telangiectasia of the eyelid margin, meibomitis, chalazia, conjunctival hyperaemia and papillary conjunctivitis.

[0199] The term "treatment" can include treatment in humans and/or other animals.

[0200] The pharmaceutical compositions according to some embodiments of the invention can be useful for the treatment of the eyes topically, orally, parenterally or rectally.

[0201] The topical application is the most common method of administration of ophthalmic medicaments. The topical route makes possible the instillation into the eye of drops or the application in the eye of solutions, eyewashes, suspensions, salves, ointments, gels, sprays, foams, powders, lotions, viscoelastic solutions and/or the deploying of solid forms at the surface of the eye, impregnated pads, syndets or wipes.

[0202] Some formulations can also be provided in the form of suspensions of microspheres or nanospheres or of vesicles formed from lipid or polymer or of polymeric patches and of hydrogels making possible controlled release. These compositions for topical application can be provided in anhydrous form, in aqueous form or in the form of an emulsion.

[0203] The pharmaceutical compositions for topical application are preferably non-irritating and compatible with the tissues of the eye. The solutions can be sterile preparations, and can be free from all particles. The suspensions can be sterile preparations, and can include solid particles in a liquid vehicle appropriate for ocular instillation. The ointments can be semisolid and sterile preparations.

[0204] Orally, the pharmaceutical compositions can be provided in liquid, pasty or solid form, in the form of powders and more particularly in the form of tablets, including sugar-coated tablets, hard gelatin capsules, syrups, suspensions, solutions, powders, granules, emulsions, microspheres or nanospheres or vesicles formed from lipid or polymer making possible controlled release. Parenterally, the compositions can be provided in the form of solutions or suspensions for infusion or for injection. Rectally, the com-

positions can be provided in the form of suppositories. In some cases, the pharmaceutical compositions are topical ophthalmic compositions, and not oral or rectal compositions.

[0205] The compositions can in some embodiments comprise from 0.001% to 10% of at least one compound selected from the family of isoxazoline parasiticides, formamidine parasiticides, agents to treat Alzheimer's disease, and/or other agents as disclosed herein, by weight with respect to the total weight of the composition. In some embodiments, the compositions according to the invention comprise from 0.01% to 5% of at least one compound selected from the family of the isoxazoline parasiticides, by weight with respect to the total weight of the composition.

[0206] In some embodiments, the compositions according to the invention are provided in the form of an eyewash or of eye drops. The term "eyewash" means a liquid formulation specifically appropriate for administration to the conjunctiva of the eye and the cornea. The eyewash can include a volume of the instilled drops of, e.g., approximately 25-50 microliters. In some embodiments, compositions are supplied as a kit, for example an eyedrop and shampoo, and may be used along with sterilizing agents such as tea tree oil and derivatives, and hypochlorous acid, which have also been shown to have *Demodex* activity, or not include tea tree or other oils in some cases.

[0207] As indicated above, the compositions can in some embodiments meet specific conditions in order to be applied in the eye. Such conditions include, in particular, sterility, absence of irritation and compatibility with the tissues of the eye. The latter criterion is more difficult to obtain than for a composition applied to the skin; in particular, compounds such as ethanol or glycols, formulated in compositions to be applied to the skin, cannot in some cases be included in compositions for ocular use.

[0208] The topical compositions can make it possible to directly and specifically treat the symptoms of the pathology in the eye and eyelids by a local action; in particular, since only the eye is targeted, a better effectiveness can be expected.

[0209] In some embodiments, a formulation can be in a solution, suspension, cream, ointment, or other form.

[0210] A liquid composition, which is formulated for topical ophthalmic use, is formulated such that it can be administered topically to the eye. The comfort may be maximized as much as possible, although sometimes formulation considerations (e.g. drug stability) may necessitate less than optimal comfort. In the case that comfort cannot be maximized, the liquid may be formulated such that the liquid is tolerable to the patient for topical ophthalmic use. Additionally, an ophthalmically acceptable liquid may either be packaged for single use, or contain a preservative to prevent contamination over multiple uses.

[0211] For ophthalmic application, solutions or medications are often prepared using a physiological saline solution as a major vehicle. These vehicles include, but are not limited to, polyvinyl alcohol, povidone, hydroxypropyl methyl cellulose, poloxamers, carboxymethyl cellulose, hydroxyethyl cellulose and purified water. Ophthalmic solutions may preferably be maintained at a comfortable pH with an appropriate buffer system. The formulations may also contain pharmaceutically acceptable preservatives, stabilizers and surfactants.

[0212] In some embodiments, a topical formulation does not include a dermal penetration enhancer, which could increase systemic absorption and be contrary to the intent of maintaining the formulation locally at or proximate the site of application in some cases. In some embodiments, a formulation does not include any dermal penetration enhancers, such as one or more of Laurocapram (Azone®) and laurocapram derivatives, such as 1-alkylazacycloheptan-2-ones, and oleic acid and its ester derivatives, such as methyl, ethyl, propyl, isopropyl, butyl, vinyl and glyceryl monooleate, and sorbitan esters such as sorbitan monolaurate and sorbitan monooleate, and other fatty acid esters such as isopropyl laurate, isopropyl myristate, isopropyl palmitate, diisopropyl adipate, propylene glycol monolaurate and propylene glycol monooleate, and long chain alkyl esters of 2-pyrrolidone, particularly the 1-lauryl, 1-hexyl and 1-(2-ethylhexyl) esters of 2-pyrrolidone and those dermal penetration enhancers such as dodecyl (N,N-dimethylamino) acetate and dodecyl (N,N-dimethylamino) propionate and 2-n-nonyl-1-3-dioxolane. However, some embodiments of formulations can include one or more dermal penetration enhancers.

[0213] In some embodiments, a topical formulation can include one or more gelling agents. The gelling agent could be a copolymer, such as Pemulen™ TR1 and/or TR2 polymeric emulsifiers (Lubrizon Corp., Wickliffe, Ohio) which are high molecular weight, copolymers of acrylic acid and C10-C30 alkyl acrylate crosslinked with allyl pentaerythritol. They are fluffy, white powders and are primarily used to form stable oil-in-water emulsions. Pemulen polymers include both hydrophilic and hydrophobic portions within the molecule. The hydrophobic portion of the polymer adsorbs at the oil-water interface, and the hydrophilic portion swells in the water forming a gel network around the oil droplets to provide emulsion stability. Pemulen polymers can form stable oil-in-water emulsions without the need for any additional surfactants. Therefore, they can be advantageous for developing low irritancy lotions and creams, for example. Pemulen polymers provide viscosity building and high yield value to allow for suspension and stabilization of insoluble materials and particulates. In some embodiments, the gelling agent can be absent, or present in the formulation between about 0.001% and about 1%, between about 0.01% and about 0.10%, or about 0.001%, 0.005%, 0.01%, 0.02%, 0.03%, 0.04%, 0.05%, 0.06%, 0.07%, 0.08%, 0.09%, 0.10%, 0.15%, 0.20%, 0.25%, 0.30%, 0.35%, 0.40%, 0.45%, 0.50% w/w of the formulation, or ranges including any two of the foregoing values.

[0214] In some embodiments, an oil-based formulation such as a cream, ointment, or emulsion for example can include one or more of mineral oil, castor oil, or petrolatum, such as between about 20% and about 80%, or between about 30% and about 70% w/w of the formulation. The formulation can also include a cyclodextrin as a carrier molecule to facilitate dissolution.

[0215] In some embodiments, a topical formulation can include one or more thickening agents, including a polysaccharide thickener, such as hydroxypropylmethylcellulose (HPMC) and sodium CMC. In some embodiments, the thickening agent can be present between about 0% and about 2%, between about 0.10% and about 1.00%, between about 0.25% and about 1.00%, or about 0.10%, 0.20%, 0.25%, 0.30%, 0.35%, 0.40%, 0.50%, 0.60%, 0.70%, 0.80%, 0.90%, 1.00% w/w of the formulation, or ranges including

any two of the foregoing values, such as between about 0.1% and about 0.5%. In some embodiments, the formulation can have a viscosity of between about 50 cP and about 100 cP in order to increase the residence time of the formulation in the eye. In some embodiments, a formulation can include a viscosity, for example, of at or above 5 cP or 20 cP or 40 cP or 100 cP or 250 cP or 400 cP or 1000 cP or more, or ranges including any two of the foregoing values. In some cases, the formulation is configured to have a residence time in the eye of between about 90 seconds and about 10 minutes, or about or at least about 60 seconds, 90 seconds, 120 seconds, 180 seconds, 240 seconds, 300 seconds, 6 minutes, 7 minutes, 8 minutes, 9 minutes, 10 minutes, or ranges including any two of the foregoing values.

[0216] In some embodiments, a topical formulation can include one or more solubilizer agents and/or surfactants, including a non-ionic surfactant such as a polysorbate, such as Polysorbate 80, Polysorbate 65, Polysorbate 60, Polysorbate 40, or Polysorbate 20. In some embodiments, Polysorbate 80 has been found to unexpectedly result in increased solubility of an isoxazoline parasiticide over other polysorbates. Other surfactants, such as a fluorinated surfactant for example can be substituted or used in addition to a non-ionic surfactant. In some embodiments, the solubilizer agents and/or surfactants can be present between about 0% and about 5%, between about 0.10% and about 4%, between about 0.50% and about 4%, or about 0.50%, 0.75%, 1.00%, 1.25%, 1.50%, 1.75%, 2.00%, 2.25%, 2.50%, 2.75%, 3.00%, 3.25%, 3.50%, 3.75%, 4.00%, 4.25%, 4.50%, 4.75%, 5.00% w/w of the formulation, or ranges including any two of the foregoing values. Polysorbate-80 may also be replaced with Cremphor EL (hydrogenated castor oil) up to FDA monograph limits of 5%, such as about 1%, 2%, 3%, 4%, or 5%, or between about 1% and 5%, or ranges including any two of the aforementioned values, to facilitate higher drug concentrations.

[0217] In some embodiments, a formulation (including but not limited to an eye drop, cream, ointment, or other form as disclosed elsewhere herein) can include both a castor oil (e.g. m hydrogenated castor oil) and a polysaccharide thickener such as HPMC or sodium CMC. In some cases, the combination can advantageously and unexpectedly form a long-lasting film layer.

[0218] In some embodiments, a topical formulation can include one or more tonicity agents, such as glycerin, dextrose, mannitol, potassium chloride, and/or sodium chloride, for example. In some embodiments, the tonicity agent (s) can be present between about 0% and about 5%, between about 0.10% and about 4%, between about 0.50% and about 4%, or about 0.50%, 0.75%, 1.00%, 1.25%, 1.50%, 1.75%, 2.00%, 2.25%, 2.50%, 2.75%, 3.00%, 3.25%, 3.50%, 3.75%, 4.00%, 4.25%, 4.50%, 4.75%, 5.00% w/w of the formulation, or ranges including any two of the foregoing values.

[0219] In some embodiments, a topical formulation can include one, two, or more buffering agents. Buffering agents can include, for example, acetate buffers, citrate buffers, phosphate buffers and borate buffers. Acids or bases may be used to adjust the pH of these formulations as needed. The buffering agent could be one or more of sodium bicarbonate buffer, calcium bicarbonate buffer, tris(hydroxymethyl)aminomethane (Tris or THAM), MOPS (3-(N-morpholino)propanesulfonic acid) buffer, HEPES (N-(2-hydroxyethyl)piperazine-N'-(2-ethanesulfonic acid) buffer, ACES (2-[(2-

amino-2-oxoethyl)amino]ethanesulfonic acid) buffer, ADA (N-(2-acetamido)-2-iminodiacetic acid) buffer, AMPSO (3-[(1,1-dimethyl-2-hydroxyethyl)amino]-2-propanesulfonic acid) buffer, BES (N,N-bis(2-hydroxyethyl)-2-aminoethanesulfonic acid) buffer, Bicine (N,N-bis(2-hydroxyethylglycine) buffer, Bis-Tris (bis-(2-hydroxyethyl)imino-tris(hydroxymethyl)methane) buffer, CAPS (3-(cyclohexylamino)-1-propanesulfonic acid) buffer, CAPSO (3-(cyclohexylamino)-2-hydroxy-1-propanesulfonic acid) buffer, CHES (2-(N-cyclohexylamino)ethanesulfonic acid) buffer, DIPSO (3-[N,N-bis(2-hydroxyethyl)amino]-2-hydroxy-propanesulfonic acid) buffer, HEPPS (N-(2-hydroxyethyl)piperazine)-N'-(3-propanesulfonic acid) buffer, HEPPSO (N-(2-hydroxyethyl)piperazine)-N'-(2-hydroxy-propanesulfonic acid) buffer, MES (2-(N-morpholino)ethanesulfonic acid) buffer, triethanolamine buffer, imidazole buffer, glycine buffer, ethanolamine buffer, phosphate buffer, MOPSO (3-(N-morpholino)-2-hydroxypropanesulfonic acid) buffer, PIPES (piperazine-N,N'-bis(2-ethanesulfonic acid) buffer, POPSO (piperazine-N,N'-bis(2-hydroxypropanesulfonic acid) buffer; TAPS (N-tris(hydroxymethyl)methyl-3-aminopropanesulfonic acid) buffer, TAPSO (3-[N-tris(hydroxymethyl)methylamino]-2-hydroxy-propanesulfonic acid) buffer, TES (N-tris(hydroxymethyl)methyl-2-aminoethanesulfonic acid) buffer, tricine (N-tris(hydroxymethyl)methylglycine) buffer), 2-amino-2-methyl-1,3-propanediol buffer, and 2-amino-2-methyl-1-propanol buffer, as well as combinations thereof. In some embodiments, the buffering agent is Tris and/or disodium hydrogen phosphate (Na_2HPO_4) and sodium dihydrogen phosphate heptahydrate ($\text{NaH}_2\text{PO}_4 \cdot 7\text{H}_2\text{O}$). In some embodiments, the buffering agents can be present between about 0% and about 2%, between about 0.01% and about 1%, between about 0.01% and about 0.75%, or about 0.01%, 0.02%, 0.03%, 0.04%, 0.05%, 0.06%, 0.07%, 0.08%, 0.09%, 0.10%, 0.11%, 0.12%, 0.13%, 0.14%, 0.15%, 0.20%, 0.25%, 0.30%, 0.35%, 0.40%, 0.45%, 0.50%, 0.55%, 0.60%, 0.65%, 0.70%, 0.75%, 0.80%, 0.85%, 0.90%, 0.95%, 1.00% w/w of the formulation, or ranges including any two of the foregoing values. The buffering agents can be selected in a therapeutically effective amount such that the pH of the pharmaceutical composition can be, for example, between about 7.35 and about 7.65, between about 7.45 and 7.55, or about 7.30, 7.35, 7.40, 7.45, 7.50, 7.55, 7.60, or ranges including any two of the foregoing values.

[0220] In some embodiments, a topical formulation can include one or more preservative agents, including but not limited to lauralkonium chloride and benzalkonium chloride. Other preservatives can include, for example, PHMB, chlorobutanol, thimerosal, phenylmercuric acetate and phenylmercuric nitrate. In some embodiments, the preservative agent can be present in the topical formulation between about 0.001% and about 0.1%, between about 0.001% and about 0.01%, or about 0.001%, 0.002%, 0.003%, 0.004%, 0.005%, 0.006%, 0.007%, 0.008%, 0.009%, 0.010% w/w of the formulation, or ranges including any two of the foregoing values.

[0221] The pharmaceutical compositions according to some embodiments of the invention can additionally comprise inert additives or combinations of these additives, such as: wetting agents, emollients; agents for improving flavor; preservatives; stabilizing agents; agents for regulating moisture; pH-regulating agents; buffers; agents for modifying osmotic pressure; emulsifying agents; agents for increasing

viscosity; and antioxidants. Ophthalmically acceptable antioxidants include, but are not limited to, sodium metabisulfite, sodium thiosulfate, acetylcysteine, butylated hydroxyanisole and butylated hydroxytoluene. Other excipient components, which may be included in the ophthalmic preparations, are chelating agents. A useful chelating agent is edetate disodium (EDTA), although other chelating agents may also be used in place or in conjunction with it.

[0222] In some embodiments, a pharmaceutical composition can include a tocopherol. In some cases, a tocopherol can be effective in preventing degradation of an isoxazoline in water. In some cases, the vitamin E is a tocopherol; in a further embodiment the tocopherol is an alpha- or a gamma-tocopherol; more preferred is an alpha-tocopherol. In some embodiments, a pharmaceutical composition does not include a tocopherol.

[0223] In some embodiments, a pharmaceutical formulation does not include any essential oils, such as tea tree oil, alpha-Terpineol, Cardinene, d-Carvone, l-Carvone, gamma-Terpinene, alpha-Terpinene, 1,8-Cineole, alpha-Terpineol, para-Cimene, alpha-Pinene, Limonene, alpha-Thugene, Eucalyptol, (+)-Ledene, Cuminic Aldehyde, or Myrcene. However, some embodiments can include one or more of the foregoing essential oils.

[0224] In some embodiments, optional compound or compounds can be added to these compositions such that the advantageous properties intrinsically associated with some embodiments of the present invention are not, or not substantially, detrimentally affected by the envisaged addition, for example tetracyclines or omega-3 fatty acids, which may have favorable effects in blepharitis.

[0225] In some embodiments, an isoxazoline parasiticide is administered orally to a patient with blepharitis, rosacea, or other conditions as disclosed elsewhere herein. Because one target organism, *Demodex folliculorum* (and/or *Demodex brevis*), is an ectoparasite in the mite family, an effective treatment in some cases is therapeutically eradicating the entire life cycle of such a microscopic insect, including egg, larval, and adult stages. For this reason, some embodiments treat blepharitis and/or rosacea patients with at least two doses timed so that between about three and about seven days separate the doses. Such spacing allows time for *Demodex* eggs to hatch into immature mites that are killed before they can mature into egg-producing adults. In some embodiments, 1, 2, 3, 4, or more doses at three- to seven-day intervals could be employed. After an isoxazoline parasiticide or other active agent as disclosed herein carries out its miticidal activity on skin *Demodex folliculorum* organisms (and/or *Demodex brevis* organisms), inflammatory responses to them begin to diminish but remnants of the dead mites still elicit some flushing and lesion formation until the cleanup processes of the body remove them, a process requiring six to eight weeks in some cases. During this initial phase of administration, other medications such as oral tetracycline and topical metronidazole, and/or anti-inflammatory agents such as NSAIDs and/or steroids can be employed to suppress early flareups and to give early clinical response. However, in some embodiments, a formulation or method does not involve a tetracycline or other antibiotic, steroid, and/or metronidazole. After prolonged intervals of freedom from symptoms, should classic signs begin to reappear, treatment can be repeated.

[0226] In an alternative embodiment, isoxazoline parasiticides can be formulated into a cosmetically-acceptable topi-

cal lotion, cream, or gel and applied to skin, eyelids, eyelashes, meibomian glands, or other anatomical locations as noted elsewhere herein. In some cases, such a route of treatment can require once- or twice-daily applications for as long as four weeks to achieve sufficient follicle penetration and effective miticidal activity. A topical formulation that could achieve this effect could contain, for example, about 0.01-5% active ingredient in some cases and could be enhanced in penetration if the active agent were encapsulated inside microliposomes. Such a topical treatment would likely need to be repeated more frequently than the preferred oral embodiment, but a disease-free interval should be achieved by each course of therapy.

[0227] In some embodiments, the pharmaceutical formulation including any disclosed herein can be configured to advantageously allow for eradication of the mite proximate an eyelash via preferential absorption of the pharmaceutical formulation through the exoskeleton (e.g., abdomen or opisthsoma) of the mite rather than ingestion of the pharmaceutical formulation by the mite (e.g., by ingesting skin cells, sebum, and other elements that could include an amount of active agent via systemic absorption). Not to be limited by theory, *Demodex* mites have a hydrophobic chitin outer surface, and a relatively thin exoskeleton in the abdomen/opisthsoma area (about 0.5 μm , vs. about 2.0 μm for the cephalothorax portion), which surprisingly has allowed for more rapid absorption of the formulation through the abdomen, instead of primarily via ingestion as in previous veterinary formulations of isoxazoline parasiticides. FIGS. 1A-B schematically illustrate application of a formulation 120 onto an eye 140 with an iris/pupil 142. An eyelid around the eye 140 may include a hair follicle 180 for an eyelash 186 and the follicle 180 may include sebum oil 182. The eyelid may include a meibomian gland 160 with meibum oil 162. As shown in FIGS. 1A-B, a "face down" orientation of the mites (e.g. *Demodex folliculorum* 164, *Demodex brevis* 184) with respect to the hair follicle 180 or a Meibomian gland 160 (with the mite body pointing to the opening of the follicle 180 or the gland 160) may facilitate the preferential abdominal absorption of the formulation 120 through abdomen/opisthsoma area 190. In ex vivo studies, it has been surprisingly observed that following delivery of certain pharmaceutical formulations as disclosed herein that the abdomen and tail portion of a *Demodex* mite stops moving more quickly than the cephalothorax as in FIG. 2, indicating *Demodex* mites are especially susceptible to topical ophthalmic formulations as disclosed herein.

[0228] In some embodiments, compositions and methods as disclosed herein can be used alone or in combination with any number of the following agents, in topical or other forms, which can be made into formulations having parameters including any features including but not limited to concentrations, excipients, and other features or absence of other features as disclosed elsewhere herein: albendazole, cambendazole, fenbendazole, flubeidazole, mebendazole, oxfendazole, parabendazole, tiabendazole, triclabendazole, amitraz, demiditraz, clorsulon, closantel, oxyclozamide, rafoxanide, cyphenothrin, flumethrin, permethrin, promazine, derquantel, diamphenetide, dicycianiil, dinotefuran, imidacloprid, nitenpyram, thiamethoxam, abamectin, doramectin, emamectin, eppinomectin, ivermectin, moxidectin, selamectin, milbemycin oxime, emodepside, epsiprantel, fipronil, fluazuron, fluhexafon, indoxacarb, levamisol, lufenuron, metaflumizone, methoprene, monepantel, moran-

tel, niclosamide, nitroscanate, nitroxyinii, novaluron, oxantel, praziquantel, pyrantel, pynprole, pvriproxifen, sisaproml, spinosad, spinetoram, lindane, picrotoxin, dieldrin, alpha-endosulfan, and/or triflumezopyrim. In some embodiments, compositions and methods can include a metadamide (e.g., broflanilide), a cyclodiene, and/or a macrocyclic lactone (including avermectins and milbemycin). In some embodiments, an Alzheimer's disease drug can be the active agent, such as galantamine, donepezil and other piperidine analogues, rivastigmine and other carbamate analogues, tacrine, 7-methoxytacrine, other pyridine analogues, huperazine A and other alkaloid analogues, which can also have anti-*Demodex* activity. Galantamine for example is a selective, competitive rapidly reversible acetylcholinesterase inhibitor with the anionic substrate and aromatic gorge, and an allosteric ligand/activator at the nicotinic cholinergic receptors, thus increasing GABA activity. Other acetylcholinesterase inhibitors could be utilized as well in some cases. Derivatives, analogues, and L- and D-isomers thereof, including but not limited to enantiomers, compositions comprising racemic mixtures, and enantiomerically pure compositions of any of the foregoing in this paragraph can also be utilized. In some embodiments, a formulation does not include any number of, or all of the agents listed in this paragraph.

[0229] In some embodiments, a dermatologic and/or ophthalmologic formulation can include an active therapeutic agent of a formamidine parasiticide instead of, or in addition to a isoxazoline parasiticide as disclosed above. A formamidine parasiticide can be, for example, amitraz, which can function as an octopamine receptor modulator. N-(2,4-Dimethylphenyl)-N-methylformamidine (DPMF), a metabolite of amitraz, is thought to be an active agent that exerts acaricidal and insecticidal effects by acting as an agonist on octopamine receptors, and can be another active therapeutic agent, alone or in addition. 2,4-dimethylaniline is a hydrolysis metabolite of DPMF and can also be an active therapeutic agent in other embodiments. Derivatives, analogues, and L- and D-isomers thereof, including but not limited to enantiomers, compositions comprising racemic mixtures, and enantiomerically pure compositions can also be utilized. In some embodiments, a dermatologic and/or ophthalmologic formulation can include an active therapeutic agent of a phenylpyrazole parasiticide instead of, or in addition to a isoxazoline or formamidine parasiticide as disclosed above. The chemical structures of these insecticides are characterized by a central pyrazole ring with a phenyl group attached to one of the nitrogen atoms of the pyrazole. Some non-limiting examples of phenyl pyrazole parasiticides include, for example, acetoprole, ethiprole, fipronil, flufiprole, pyraclofos, pyraflprole, pyriprole, pyrolan, and vaniliprole.

[0230] To further illustrate some embodiments and advantages thereof, Table 1 below lists several non-limiting specific examples of topical isoxazoline parasiticide formulations for illustrative purposes only. All ingredients are listed as % w/w or grams/100 grams of preparation, and FIGS. 3A-3B shows examples of formulations with amitraz and fluralaner.

[0231] One example embodiment of an amitraz solution includes 0.100% w/w of Amitraz in 99.9% light mineral oil. Another example of an amitraz ointment can include 0.100% w/w of Amitraz and 29.9% mineral oil and 70.0% petrolatum.

TABLE 1

Ingredient	Solution 1	Solution 2	Suspension 1
Fluralaner	0.0100	0.0250	0.500
Pemulen TR1	0	0	0.050
HPMC	0.50	0.50	0
Polysorbate 80	2.0	2.0	2.0
Glycerin	2.5	2.5	2.5
TRIS	0	0	0.050
NaH ₂ PO ₄ ·7H ₂ O	0.44	0.44	0
Na ₂ HPO ₄	0.045	0.045	0
pH	7.5	7.5	7.5
Lauralkonium Chloride	0.0050	0.0050	0.0050
Water	q.s. ad 100%	q.s. ad 100%	q.s. ad 100%

[0232] In some embodiments, a topical ophthalmic formulation can include the following instructions for use. A patient can be instructed to shower or bathe first before applying the study medication, and wash their hands before applying the study medication. A unit dose, such as a single drop of the formulation can be directly applied into each eye once or twice a day, e.g., once in the morning and once in the evening. After delivering the drop to the conjunctiva and/or cornea of the eye, the patient can close their eyes and apply gentle pressure to the upper lid to express the medication across their upper and lower eyelid margins. The formulation can then be allowed to dry without dabbing with a tissue. The formulation can then be stored at room temperature in a climate-controlled environment (15 to 30° C.), avoiding extreme heat or cold. In some embodiments, the patient is instructed not to apply any other topical ophthalmic medications within a specified period, e.g., one hour before and one hour after administering the study medication.

[0233] In some embodiments, systems and methods include qualitative and/or quantitative assessment of *Demodex* on an anatomical location of the patient, such as on eyelashes and/or within glands, for example. In some embodiments, a method can include receiving a first assessment of a quantity of *Demodex* mites on an anatomical structure of the patient, and initiating topical administration of the dermatologic and/or ophthalmic composition if the quantity of *Demodex* mites is greater than a predetermined value, such as greater than about 1, 1.5, 2, 2.5, 3, 4, 5, or more mites per square centimeter of skin (or mites per lash). In some embodiments, a method can include receiving a second assessment of a quantity of *Demodex* mites following therapy to quantitatively assess improvement, and either continuing, modifying (via an increase or decrease in dose, frequency, formulation, and the like), or discontinuing therapy based on the second assessment, which can be about, no more than about, or at least about 1 day, 2 days, 3 days, 5 days, 7 days, 10 days, 14 days, 21 days, 28 days, 30 days, or more or less after the first assessment. In some embodiments, the therapy results in a reduction of about or at least about 10%, 20%, 30%, 40%, 50%, 60%, 70%, 80%, 90%, or 100% eradication of the *Demodex* at the anatomic location.

[0234] The presence of cylindrical dandruff, also known as cylindrical casts, are scales that form clear cuffs collaring the eyelash root, at the base of the eyelash. Cylindrical dandruff on an eyelash is generally considered pathognomonic for *Demodex* infestation, can be diagnosed via epilation and viewed under a slit lamp microscope, and then counted automatically or manually. Skin surface biopsy

(SSB) technique with cyanoacrylic adhesion is a commonly used method to measure the density of *Demodex*. It allows the collection of the superficial part of the horny layer and the contents of the pilo-sebaceous follicle. Other sampling methods used in assessing the presence of *Demodex* by microscopy include adhesive bands, skin scrapings, skin impressions, expressed follicular contents, comedone extraction, hair epilation, and punch biopsies.

[0235] In some embodiments, systems and methods for detecting *Demodex* in a subject are disclosed that do not necessarily require epilation. Such measures of diagnosis of *Demodex* can be advantageous because *Demodex*, particularly *Demodex brevis* can be challenging to detect and quantify via epilation. Furthermore, many patients object to epilation due to discomfort. Furthermore, initiation of treatment could be earlier and based on objective criteria.

[0236] For example, a device, such as a disposable hydrogel contact lens can be utilized to collect tears from a subject. This device, e.g., lens is then sent to a laboratory for detecting, and potentially quantifying, *Demodex* DNA by PCR or other means. The genome for both *Demodex folliculorum* and *Demodex brevis* have been sequenced. A “diagnostic” lens can be placed on the eye and removed after at a short fixed period, such as about or less than about 30, 20, 15, 10, or 5 minutes, for example. Such a lens can be made of a hydrogel with relatively high affinity for a *Demodex* biomarker, including DNA.

[0237] In some embodiments, tear sampling can utilize devices including capillary glass tubes to harvest tears from the lower lid tear meniscus as shown in FIG. 4A. This method can be especially useful when quantitative, small volumes are needed. In addition, evaporation can be eliminated, if beneficial to do so, simply by sealing both ends of the tube.

[0238] Some embodiments also include non-contact lens skin and tear sampling methods, for example a “litmus paper” or wicking paper embodiment similar to a Schirmer test (illustrated in FIG. 4B), or a lash brush harvesting technique (illustrated in FIG. 4C). In some embodiments, chitin, chitosan, or other *Demodex*-specific biomarkers that could be detected and quantified to correlate with mite numbers.

[0239] *Demodex* DNA can be quantified, for example, as the density of DNA copies coding for a particular *Demodex* target sequence (e.g., 18S rRNA as one non-limiting example). In some embodiments, a density (defined as the number of DNA copies coding for a target region of *Demodex* per ng of human gDNA ($\times 10^{-6}$) of *Demodex* can be a threshold to initiate therapy if greater than about 1, 2, 3, 4, 5, 6, 7, 8, 9, 10, 11, 12, 13, 14, 15, 16, 17, 18, 19, 20, or more.

[0240] An infestation could be further categorized as to causative species of *Demodex* (e.g., *Demodex folliculorum* vs *Demodex brevis*). *Demodex brevis* resides mostly within the meibomian and sebaceous glands. Treatment could be modified, enhanced, or targeted based on the dominant species, e.g., increasing delivery of the therapeutic formulation to selected glands, for example.

[0241] Various other modifications, adaptations, and alternative designs are of course possible in light of the above teachings. Therefore, it should be understood at this time that within the scope of the appended claims the invention may be practiced otherwise than as specifically described herein. It is contemplated that various combinations or subcombinations of the specific features and aspects of the

embodiments disclosed above may be made and still fall within one or more of the inventions. Further, the disclosure herein of any particular feature, aspect, method, property, characteristic, quality, attribute, element, or the like in connection with an embodiment can be used in all other embodiments set forth herein. Accordingly, it should be understood that various features and aspects of the disclosed embodiments can be combined with or substituted for one another in order to form varying modes of the disclosed inventions. Thus, it is intended that the scope of the present inventions herein disclosed should not be limited by the particular disclosed embodiments described above. Moreover, while the invention is susceptible to various modifications, and alternative forms, specific examples thereof have been shown in the drawings and are herein described in detail. It should be understood, however, that the invention is not to be limited to the particular forms or methods disclosed, but to the contrary, the invention is to cover all modifications, equivalents, and alternatives falling within the spirit and scope of the various embodiments described and the appended claims. Any methods disclosed herein need not be performed in the order recited. The methods disclosed herein include certain actions taken by a practitioner; however, they can also include any third-party instruction of those actions, either expressly or by implication. For example, actions such as “applying an isoxazoline parasiticide to an eye” includes “instructing the applying an isoxazoline parasiticide to an eye.” The ranges disclosed herein also encompass any and all overlap, sub-ranges, and combinations thereof. Language such as “up to,” “at least,” “greater than,” “less than,” “between,” and the like includes the number recited. Numbers preceded by a term such as “approximately,” “about,” and “substantially” as used herein include the recited numbers (e.g., about 10%=10%), and also represent an amount close to the stated amount that still performs a desired function or achieves a desired result. For example, the terms “approximately,” “about,” and “substantially” may refer to an amount that is within less than 10% of, within less than 5% of, within less than 1% of, within less than 0.1% of, and within less than 0.01% of the stated amount.

1. A method for treating *Demodex* blepharitis in a patient, comprising:

topically administering directly to an ocular surface of one or more eyes of a patient in need of treatment thereof an effective amount of an isoxazoline parasiticide, formulated into an ophthalmic composition, the ophthalmic composition further comprising a pharmaceutically acceptable vehicle,

wherein the ophthalmic composition is sterile and non-irritating to the eye,

wherein the isoxazoline parasiticide is the sole active ingredient of the ophthalmic composition.

2. The method of claim 1, wherein from about 0.01% to about 1% of the isoxazoline parasiticide with respect to the total weight of the composition is administered.

3. The method of claim 1, wherein about 0.03% by weight of the isoxazoline parasiticide with respect to the total weight of the composition is administered.

4. The method of claim 1, wherein about 0.10% by weight of the isoxazoline parasiticide with respect to the total weight of the composition is administered.

5. The method of claim 1, wherein the ophthalmic composition comprises an eye drop.

6. The method of claim 1, wherein the ophthalmic composition does not include any essential oils.

7. The method of claim 1, wherein the isoxazoline parasiticide is selected from the group consisting of: fluralaner, sarolaner, lotilaner, afoxolaner, and fluxametamide.

8. The method of claim 1, wherein the ocular surface comprises at least one of the conjunctiva or cornea of the one or more eyes of the patient.

9. The method of claim 1, wherein the ophthalmic composition comprises a polysorbate.

10. A method for treating *Demodex* blepharitis in a patient, comprising:

topically administering directly to one or more of the eye, eyelids, or eyelashes of a patient in need of treatment thereof an effective amount of an isoxazoline parasiticide, formulated into an ophthalmic composition further comprising a pharmaceutically acceptable vehicle, wherein the ophthalmic composition is sterile and non-irritating to the eye,

wherein the isoxazoline parasiticide is the sole active ingredient of the ophthalmic composition.

11. The method of claim 10, wherein the patient's eyes are closed upon topically administering the ophthalmic composition, such that the composition contacts orifices of Meibomian glands of the patient and outside of eyelid margins of the patient.

12. The method of claim 11, further comprising spreading the composition onto the eyelashes and follicles of the eyelashes.

13. The method of claim 11, further comprising spreading the composition onto the eyelashes and follicles of the eyelashes with an applicator.

14. The method of claim 10, wherein from about 0.001% to about 1% of the isoxazoline parasiticide is administered.

15. The method of claim 10, wherein from about 0.001% to about 1% of the isoxazoline parasiticide is administered.

16. The method of claim 10, comprising topically administering the ophthalmic composition at least once daily for at least about 2 weeks.

17. The method of claim 10, comprising topically administering the ophthalmic composition at least once daily for at least about 4 weeks.

18. A method for treating an ocular *Demodex* infestation in a patient, comprising:

topically administering directly to one or more of the eyes, eyelids, or eyelashes of one or more eyes of a patient in need of treatment thereof, an effective amount of an isoxazoline parasiticide, formulated into an ophthalmic composition further comprising a pharmaceutically acceptable vehicle,

wherein the ophthalmic composition is sterile and non-irritating to the eye,

wherein the isoxazoline parasiticide is the sole active ingredient of the ophthalmic composition.

19. The method of claim 18, further comprising receiving a first assessment of a quantity of *Demodex* mites on an anatomical structure of the patient, and topically administering the ophthalmic composition if the quantity of *Demodex* mites is greater than a predetermined value.

20. The method of claim 18, wherein the ophthalmic formulation causes an abdomen and tail of *Demodex* mites on the patient to stop moving more quickly relative to a cephalothorax of the *Demodex* mites.

* * * * *